



Owner/Operator Manual

TRAIL BLAZER® Sickle Bar Mower

- Safety
- Assembly
- Controls
- Operation
- Maintenance

Models

3½ HP
4 HP

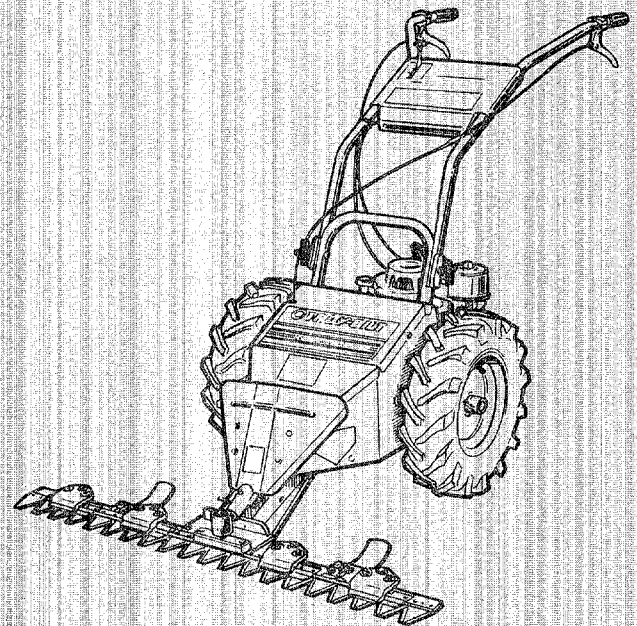

⚠ DANGER

The mower's cutter bar can cause serious personal injury. Read this Owner/Operator Manual thoroughly for precautions you must follow when operating the mower. *Always* follow these precautions.

⚠ WARNING

Avoid fires due to sparks.

Do not operate engine if spark arrester screen is loose or damaged.

PLEASE NOTE

All directions in this Manual are determined from the operator's position, standing behind the handlebars and facing forward. Please refer to the figure below.

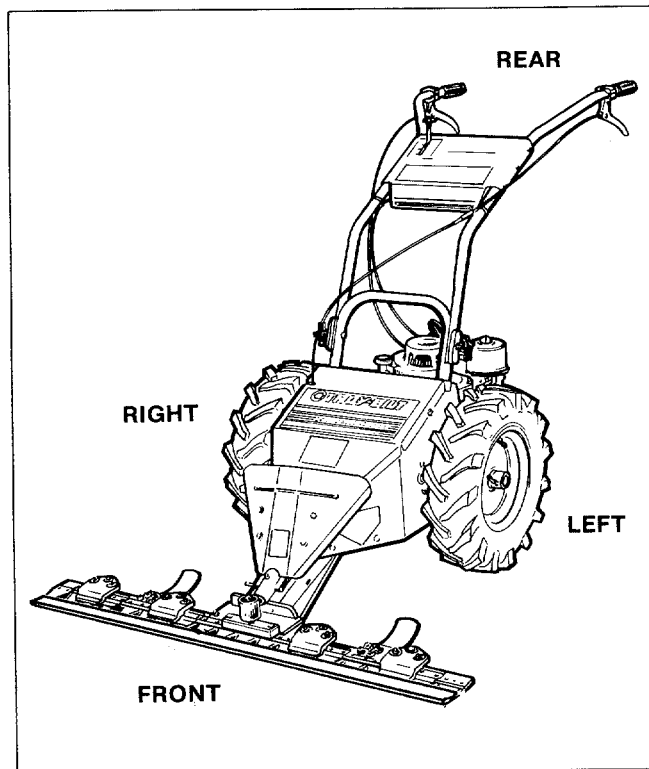

IMPORTANT!

If you notice any freight damage either at the time of delivery or later during assembly, make sure that you notify the truck terminal that delivered your mower that you intend to file a claim. If you have any problems with this procedure, please call us so that we can help you get satisfaction. Our phone numbers are listed on Page 3 and on the back cover of this manual.

TABLE OF CONTENTS

	Page		Page
Section 1: Safety	4	Section 5: Maintenance	18
Training	4	Engine Maintenance	18
Preparation	4	Checking the Engine Oil Level and	
Operation	4	Adding Oil to the Engine	18
Disconnecting the Spark Plug Wire	5	Changing the Engine Oil	19
Maintenance and Storage	5	Air Filter Maintenance	19
Decals	5	Spark Arrester	20
		Air Cooling System Maintenance	21
		Carburetor Adjustment (Engine	
		Speed & Mixture)	21
		Engine Ignition System	21
		Spark Plug	21
		Liquid Lock	21
		Mower Maintenance	22
		Lubrication	22
Section 2: Easy Assembly	6	Removing and Reinstalling the Wheels	23
		Wheel Drive Belt Removal and	
		Installation	23
		Wheel Drive Adjustment (General)	27
		Wheel Drive Check	27
		Wheel Drive Initial Setting	28
		Wheel Drive Main Adjustment	28
		Cutter Bar Drive Belt Removal and	
		Installation	29
Section 3: Engine and Mower Controls	12	Cutter Bar Drive Adjustment (General)	32
Blade Drive Lever	12	Cutter Bar Drive Check	32
Wheel Drive Lever	12	Cutter Bar Drive Initial Setting	32
Cutting Height Adjusters	13	Cutter Bar Drive Main Adjustment	33
Handlebar Height Adjustment	13	Cutter Bar Maintenance	34
Engine Throttle Lever	14	Removal and Installation of the	
Engine Choke	14	Cutter Bar Assembly	34
Recoil Starter	14	Blade Guide Maintenance	35
Engine Ignition Switch		Blade Guide Adjustment	36
(Electric Start Models)	14	Removing and Installing the Cutter	
		Blade Assembly	36
		Tightening a Loose Individual Blade	37
		Replacing Individual Blades	38
Section 4: Mower Operation	15	Electric Starting System Maintenance	40
Filling the Engine's Gas Tank	15	Battery Charging	40
Starting the Mower	16	Seasonal Charging	40
Mowing	16	Battery Removal & Installation	41
Stopping	17		
General Mowing Tips	17	Storage	42
		Maintenance Schedule	42
		Troubleshooting Chart	43
		Alphabetical Index	inside rear cover
		Specifications	inside rear cover

Dear Owner:

Congratulations on the purchase of your TROY-BILT TRAIL BLAZER® Sickle Bar Mower. You will find this mower to be a unique and useful piece of equipment that can be used for many projects on your property. You can use this mower for numerous tasks, such as taming those unsightly areas on your property that you never had the time to mow, cleaning up any badly overgrown spots that are threatening to surround your out-buildings, making an occasional pass over the edges of your property to keep your property lines clear, or making a single path through head-high weeds and saplings to make a nature trail or a cross country trail that can be enjoyed all year long.

Because of the TROY-BILT TRAIL BLAZER® Mower's ease of operation and well-balanced build, you can do all of the above-mentioned projects easily with little more effort than simply walking behind the mower. The mower's cutter bar has induction hardened teeth that slice through weeds and small saplings in a single pass, leaving a wide swath behind.

To help you get the most value from your mower, we've prepared this Owner/Operator Manual for your use. This Manual will tell you how to easily assemble your mower and operate its controls. It also provides you with easy-to-follow procedures for performing required maintenance.

And, of course, we are never more than a phone call away. If you should ever have any questions about your mower, or need to order any parts, please call us. Our phone numbers are listed on Page 3 and on the back cover of this Manual. One of our helpful, friendly Technical Service people will be glad to assist you.

Sincerely,



Dean Leith, Jr.
Sales Manager

RECORD YOUR MOWER'S SERIAL AND MODEL NUMBERS

The arrow in the photo shows the location of the serial number and model number decals on your TRAIL BLAZER® Mower. Please record these numbers in the spaces below. If you should ever need any replacement parts, or if you have any questions for us, we will need to know these numbers. Also please be sure to tell us if you have an electric start or a standard start model.

MY TRAIL BLAZER® MOWER IS (CHECK ONE):

- AN ELECTRIC START MODEL.
- A STANDARD START MODEL.

ITS SERIAL NUMBER IS _____ .

ITS MODEL NUMBER IS _____ .

ITS DATE OF DELIVERY WAS _____ .

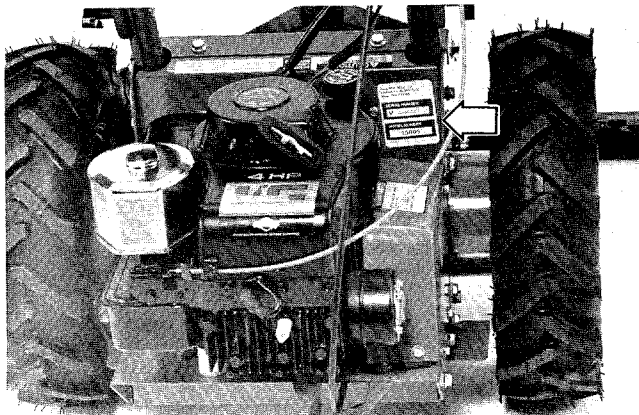

RECORD YOUR MOWER ENGINE'S IDENTIFICATION NUMBERS

Please refer to the Briggs & Stratton Operating and Maintenance Instructions Manual that was included in the literature package. This manual will show you the location of the engine's identification numbers. If you ever need any engine parts, you will need to provide its identification numbers.

To obtain engine parts or service, please look in the yellow pages of your telephone book under "ENGINES-GASOLINE" or "GASOLINE ENGINES". Then look for the name of the nearest Authorized Briggs & Stratton Service Center. If you have trouble finding a service shop, please feel free to call us and we will provide you with the name, telephone number, and address of the service center nearest you.

Please record the important engine information in the blank spaces below. This will give you a handy reference for later use.

ENGINE HORSEPOWER RATING _____ .

ENGINE MODEL/TYPE/
CODE NUMBER _____ .

FOR SERVICE OR PARTS:

If you should ever need service assistance or replacement parts for your mower, call us at the numbers listed below:

TROY-BILT MANUFACTURING CO.

102nd St. & 9th Ave., Troy, New York 12180
For Technical Service, call Toll-Free: 1-800-833-6990
For Parts Sales, call Toll-Free: 1-800-648-6776
M-F 8 a.m. to 7 p.m.
Sat. 9 a.m. to 4:00 p.m.

GARDEN WAY BRANCH CANADA

1515 Matheson Blvd. E, Unit B11
Mississauga, Ontario L4W 2P5
Call Toll-Free: 1-800-225-3585
M-F 8 a.m. to 4:30 p.m.

If you are ordering parts for your mower, please give us the following information:

1. The serial number of your mower.
2. Whether you have an electric start model or a standard start model.
3. The PART NUMBER of the part you need (from the TRAIL BLAZER® Mower Parts Catalog).
4. The PART DESCRIPTION of the part you need (from the TRAIL BLAZER® Mower Parts Catalog).
5. The QUANTITY of that particular part that you need.

(Please remember that you can get many of the common hardware items from a nearby well-stocked hardware store as well as from us.)

⚠ WARNING TO ALL CALIFORNIA MOWER OPERATORS

Under California Law, you are not permitted to operate an internal combustion engine using hydrocarbon fuels on any forest-covered, brush-covered, or grass-covered land, or land covered with grain, hay, or other flammable agricultural crop, without an engine spark arrester in continuous effective working order. The engine on your mower, like most lawn or garden equipment, is an internal combustion engine that burns gasoline (a hydrocarbon fuel); therefore it must be equipped with a spark arrester muffler in proper working order. The spark arrester must be attached to the engine exhaust system in such a manner that flames or heat from the system will not ignite flammable material. Failure of the operator to comply with this regulation is a misdemeanor under California Law. Other states may have similar laws. Federal laws apply on Federal lands.

The TRAIL BLAZER® Mower is equipped with a screen-type spark arrester on its muffler.

Please refer to Page 20 in this Manual and to the Briggs & Stratton Operating and Maintenance Instructions Manual for specific inspection and maintenance procedures for the spark arrester.

SECTION 1: SAFETY

IMPORTANT—Safe Operation Practices for Sickle Bar Mowers

When operating or servicing the mower always follow the safe operating practices described in this Section. If you should ever lend this mower to another person, make sure that he or she understands the safe operation of the mower.

If you should ever have any questions about operating or servicing your TRAIL BLAZER® Mower, please call us immediately. One of our trained technical service representatives will be happy to assist you. Our phone numbers are listed on Page 3 and on the back cover of this Manual.

TRAINING

1. Read this Owner/Operator Manual, the separate engine owner's manual, and any other literature you may have received before you use the mower. Be thoroughly familiar with the controls and proper use of the mower. Know how to stop the mower and disengage its controls quickly in case of an emergency.
2. Never allow children to operate the mower. Do not allow adults to operate the mower without proper instruction. Do not allow irresponsible adults to operate the mower.
3. Keep the area of operation clear of all persons, particularly small children, and pets.

PREPARATION

1. Thoroughly inspect the area where the mower is to be used. Remove all metal debris, limbs, and other hazards. Also inspect this area for holes, ruts, or bumps. Uneven terrain could overturn the mower. *Be aware that tall vegetation can hide many hazards.*
2. Do not operate the mower when barefoot or when wearing open sandals. Always wear substantial footwear which will protect your feet and help improve traction.
3. Do not wear loose fitting clothing or jewelry that could get caught in moving parts. Also be aware that vines, branches, etc. can snag loose fitting clothing or jewelry.
4. Remove any rings or other metal jewelry when working on or near the electric starting system.
5. Before starting the engine, make sure that the plastic blade protector is removed from the blade and that both handlebar levers are disengaged (released). Also check the muffler's spark arrester screen for security and damage.
6. Mow only in daylight.
7. Never operate the mower in wet grass. Always be sure of your footing; keep a firm hold on the handlebar grips, and walk, never run.
8. Never operate the mower without the weed deflector and all guards in place (except for the plastic blade protector, which should be removed before starting the engine).
9. Never attempt to disconnect or remove guards or other safety devices, or to defeat the purpose of these safety devices.
10. Gasoline is highly flammable and its vapors are explosive. Handle it with extreme care. Use an approved fuel container.

11. Check the gas level in the gas tank before starting the engine. Do not fill the gas tank when the mower is indoors, when the mower's engine is running, or when the mower's engine is hot. Allow the mower's engine to cool for several minutes before filling the gas tank. Reinstall the gas tank cap securely and clean up any spilled gasoline before starting the engine.
12. Keep smoking materials, sparks, and flame away from the gas tank and the fuel container.
13. Move the mower away from gas fumes before starting the engine.
14. If you are mowing in a dry area, do not smoke. Do not smoke while mowing.
15. Do not charge the battery (on electric start models) in an airtight space.
16. When charging the (electric start) mower's battery, do not use a battery charger other than the one provided with the mower.
17. The electric start mower's battery contains toxic materials. Do not damage the battery case. If the case is broken or damaged, avoid contact with the battery contents.
18. Dispose of the battery properly. Check with local authorities for proper disposal methods.
19. Do not operate the mower if the cutter bar assembly is not securely installed.

OPERATION

1. Before each use, check the operation of the handlebar levers. See Page 16 in this Manual for specific instructions. Do not use the mower if either handlebar lever is not functioning properly.
2. Do not put hands or feet near or under any moving parts. Keep clear of the cutter bar at all times when the engine is running.
3. Keep the plastic blade protector on the blade until you are ready to start the engine.
4. Before removing or installing the plastic blade protector: shut the engine off, disconnect the spark plug wire and prevent it from touching the spark plug. On electric start models, also remove the Engine Ignition key from the keyswitch.
5. Do not change the engine governor settings or overspeed the engine.
6. Stop the cutter bar blade when crossing gravel drives, walks, or roads.
7. Watch for traffic when operating near, or when crossing roadways.

8. Stop both the cutter bar blade and the wheel drive when you are approached by any child, inattentive person, or pet.
9. Before inspecting, cleaning, adjusting, or repairing the mower or cutter bar: stop the engine, disconnect the spark plug wire and prevent it from touching the spark plug, wait for all moving parts to stop, and reinstall the plastic blade protector on the blade. On electric start models, also remove the Engine Ignition key from the keyswitch.
10. Never leave the operator's position while the mower's engine is running. Stop the engine, disconnect the spark plug wire and prevent it from touching the spark plug to help prevent accidental starting. Also, remove the Engine Ignition key from the keyswitch on electric start models to help prevent accidental starting or unauthorized use.
11. If the mower should start to vibrate abnormally, stop the engine, disconnect the spark plug wire and prevent it from touching the spark plug. Also, remove the Engine Ignition key from the keyswitch on electric start models. Wait for all moving parts to completely stop and then inspect the mower for damage. Repair the damage before restarting the engine and operating the mower.
12. Do not run the engine in an enclosed area. Engine exhaust contains carbon monoxide gas, a deadly poison that is odorless, colorless and tasteless.
13. Do not mow excessively steep slopes.
14. Keep all movements on a slope slow and gradual. Do not make sudden changes in speed or direction.
15. Do not touch engine parts which may be hot from operation. Allow parts to cool before inspecting, cleaning, or repairing.
16. Whenever you pull the mower rearward, release both handlebar levers. Always check behind you for hazards when backing up.
17. If you're not mowing, disengage the blade drive.
18. Do not operate the mower while under the influence of alcohol or drugs.
19. Do not mow near drop-offs, ditches, or embankments. If the mower's wheel goes over the edge, or if the edge caves in, the mower could suddenly overturn.
20. Keep children out of the mowing area. Keep them under the watchful eye of an adult other than the person operating the mower. Never assume that children will remain where you last saw them.
21. Before you back the mower up, and while you're backing it up, be sure to look behind you for small children.
22. Never attempt to carry children on the mower. They could fall off and be seriously injured, or they could interfere with the safe operation of the mower.
23. Use extra care when approaching blind corners, shrubs, trees, and any other object that may obscure vision.
24. When removing the cutter bar blade from the cutter bar assembly, wear sturdy leather gloves to help prevent the blades from accidentally pinching or cutting your fingers or hands.

Disconnecting the Spark Plug Wire

Whenever you perform any type of cleaning, inspection, or maintenance on the mower, shut the engine off and then disconnect the spark plug wire from the spark plug. Then prevent the wire from touching the spark plug by placing the spark plug wire's boot on the V-shaped holder that is on the rear of the engine. See the photo below.

Preventing the spark plug wire from touching the spark plug helps to prevent the engine from being accidentally started.

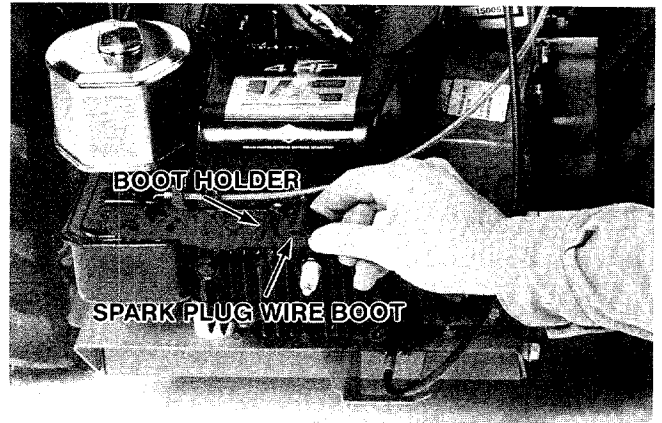

Preventing the spark plug wire from touching the spark plug.

MAINTENANCE AND STORAGE

1. Keep all nuts, bolts, and screws tight to be sure that the equipment is in safe working condition.
2. If the mower has gasoline in its gas tank, do not store it inside a building where fumes from the gasoline could reach an open flame or spark.
3. Allow the engine to cool before storing the mower in any enclosure.
4. To reduce fire hazard, keep the engine free of grass, leaves, or excessive grease.
5. Store gasoline in a cool, well-ventilated area, safely away from any spark- or flame-producing equipment. Store gasoline in an approved container, safely out of the reach of children.
6. Before inspecting, cleaning, adjusting, or repairing the mower: Stop the engine, disconnect the spark plug wire and prevent it from touching the spark plug, wait for all moving parts to stop, and reinstall the plastic blade protector on the blade. On electric start models, also remove the Engine Ignition key from the keyswitch.
7. Do not allow children to be around you when you are working on the mower.

DECALS

We've placed operating and safety decals on the mower to help you when operating the mower or to warn you of any hazards. If any of these decals is missing, illegible, or damaged, please contact us immediately for replacements. Please refer to your TRAIL BLAZER® Parts Catalog for decal location and replacement information.

SECTION 2: EASY ASSEMBLY

Please follow the assembly steps given in this Section to properly assemble your mower. These steps will not take very long and they will assure you of having assembled your mower correctly.

Before you begin assembly, please read this Section all the way through to familiarize yourself with the assembly steps. Then gather the necessary tools.

To assemble the mower, you'll need the following items:

1. One pair of scissors.
2. One flat-tipped screwdriver.
3. One quart of high quality engine oil. (See "Specifications" on the inside rear cover of this Manual for recommended types of oil.)
4. One 3/8-inch wrench.
5. A piece of wood (to tap the handle onto the Throttle Lever).
6. A 13 MM (millimeter) wrench. (You can substitute a 1/2-inch wrench).
7. A clean funnel.
8. For electric start mowers, you'll also need a 13/16-inch wrench (you can substitute a large adjustable wrench).
9. An assistant to help steady the mower.
10. Grease, multi-purpose type.

Step 1: Check your Parts

We've carefully packed your mower here at the factory. After unpacking it, compare the contents of the cartons to Photo 2-1 to make sure that you have the necessary parts to assemble your mower. If any parts are missing, please call us for replacements.

The following list of components is keyed to the callouts in Photo 2-1.

1. The upper handlebar assembly.
2. The mower body/engine assembly.
3. The mower hardware packages.
4. The cutter bar assembly, which consists of:
 - a. The ledger bar.
 - b. The cutter blade.
 - c. The plastic blade protector.
5. The drive socket.
6. The drive pin.
7. Two forward height adjuster halves.
8. Two rear height adjuster halves.

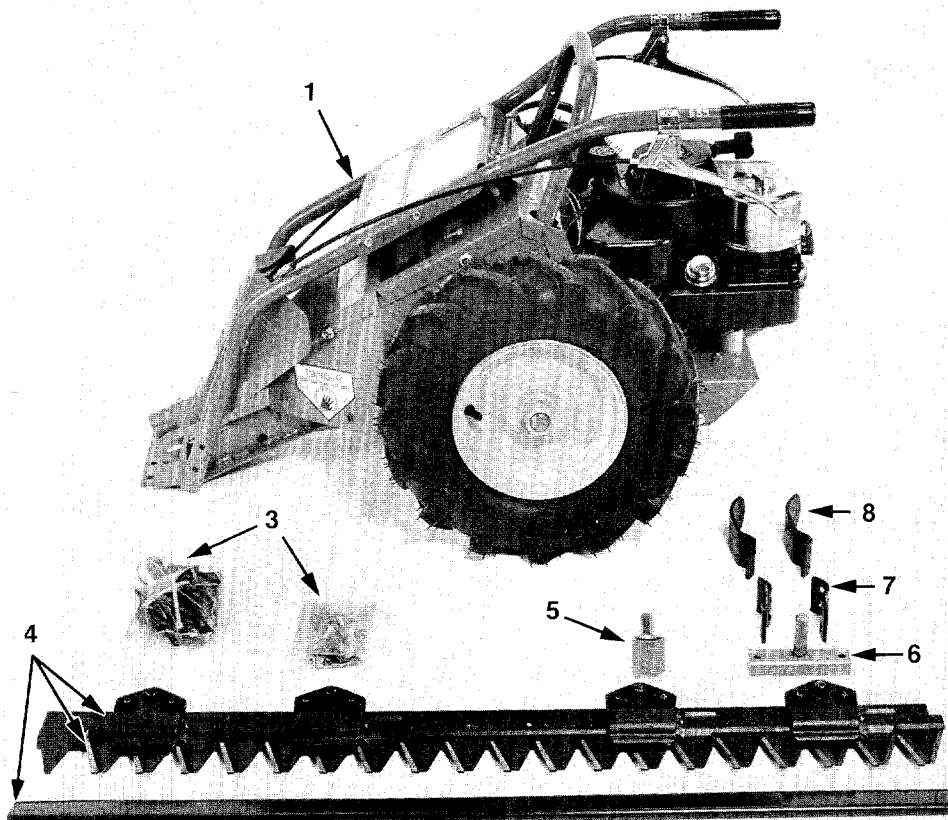

Open the hardware packages. Compare their contents with Photo 2-2 and the following list. If any pieces are missing, call us for replacements.

1. Two handlebar lock clamps.
2. Two handlebar knobs.
3. Two handlebar star washers.
4. Tie straps (four for electric start models; two for standard start models).
5. Two curved head handlebar bolts.
6. Two #10 lockwashers.
7. Two 10-32 nuts.
8. Two 10-32 x 1/2-inch slotted head screws.
9. One keyswitch (with nut and lockwasher).*
10. One pair of keys.*
11. One battery charger.*
12. Two 8 MM x 20 MM hex head screws.
13. Two 5/16-inch lockwashers.
14. Four 5/16-18 x 1 1/4-inch carriage bolts.
15. Four 5/16-18 locknuts.
16. Throttle Lever knob.
17. Height adjuster hardware (not shown):
 - a. Two U-bolts.
 - b. Four U-bolt nuts.
 - c. Four flat washers for U-bolts.
 - d. Four 8MM x 30MM carriage bolts.
 - e. Four 8MM flat washers.
 - f. Four 8MM lock nuts.

* Electric start models only.

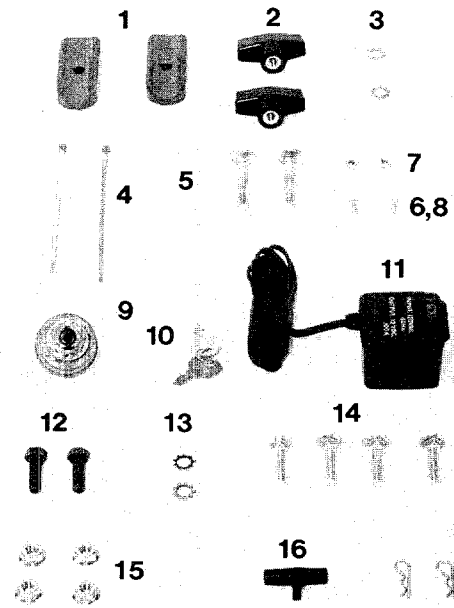

Photo 2-2: The contents of the hardware packages.

Step 2: Attaching the Handlebars

1. Slide the upper handlebars into position over the lower handlebars and align the holes.

NOTE

Use the upper set of holes (in the lower handlebars) for the higher handlebar height position. Use the lower set of holes for the lower handlebar height position.

2. From the inner side, push one of the curved head handlebar bolts through these holes.
3. Place a handlebar lock clamp over the end of this bolt. The curved side of the lock clamp faces in.
4. Place a lockwasher on the bolt.
5. Install a handlebar knob on the bolt.
6. Repeat Steps 2 through 5 for the other side of the handlebars. Very securely tighten both handlebar knobs.

NOTE

The lower handlebars are rubber mounted at their lower end to help reduce vibration to the operator. This may make them feel somewhat loose, however this is normal.



Photo 2-3: Attaching the handlebars.

EASY ASSEMBLY

Step 3: Installing the Throttle Lever

1. The throttle cable is already attached to the Throttle Lever and the carburetor. Unwrap the throttle cable and lever from the mower.
2. From underneath the control panel, insert the Throttle Lever's handle up, through the small rectangular cut-out in the control panel.
3. From above the control panel, insert one of the #10-32 x 1/2-inch screws down through one of the cut-outs in the control panel decal. Make sure that this screw goes through the hole in the base of the Throttle Lever. Loosely install one of the #10 lockwashers and one of the #10-32 nuts on this screw.
4. Install the second screw, lockwasher, and nut in the remaining hole. Then tighten both nuts with a 3/8-inch wrench and screwdriver.

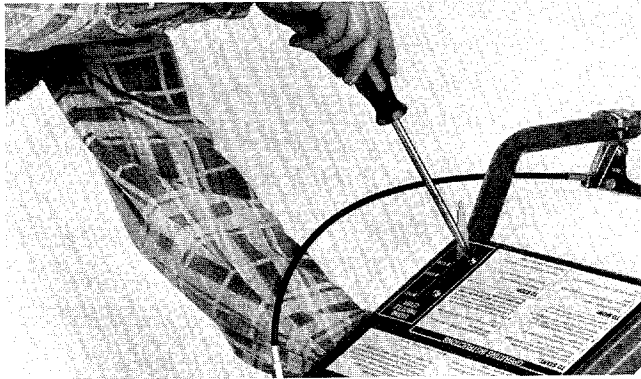
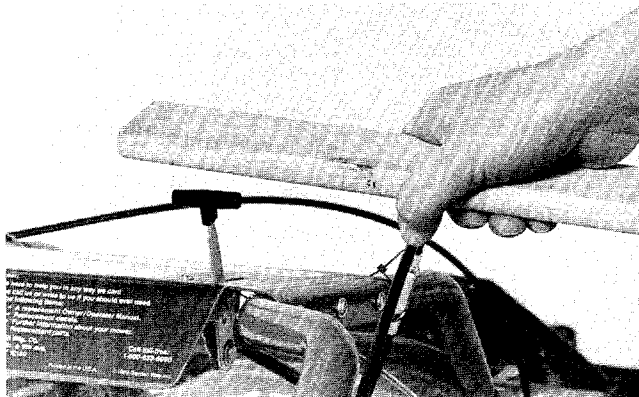

Photo 2-4: Installing the throttle lever.

5. Move the Throttle Lever forward and backward several times. If the lever binds or does not have full travel, loosen both nuts that you installed in Steps 3 and 4. From underneath the control panel, push the base of the Throttle Lever slightly to the right. Retighten both nuts and again check the Throttle Lever for free movement. If the Throttle Lever should still not move, push the carburetor's throttle arm (where the lower end of the Throttle Lever cable is secured) to the left. (Occasionally dried paint on the throttle arm pivot keeps it from moving.)
6. Place the Throttle Lever knob on top of the Throttle Lever handle. Use a piece of wood to gently tap the knob onto the Throttle Lever handle.



8 Photo 2-5: Installing the throttle lever knob.

Step 4: Assembling and Installing the Cutter Bar

CAUTION

The cutter blades are sharp. Keep the plastic blade protector on the cutter bar when working on or near the cutter bar.

Failure to do so could result in personal injury or property damage.

1. If the drive pin is not installed on the cutter blade, place it on top of the blade. Align the holes in the base of the drive pin with the holes in the cutter bar. Secure the drive pin in place with two 8 MM x 25 MM bolts and two 8 MM lockwashers. Use a 13 MM (or a 1/2-inch) wrench to evenly and securely tighten both bolts. See Photo 2-6.

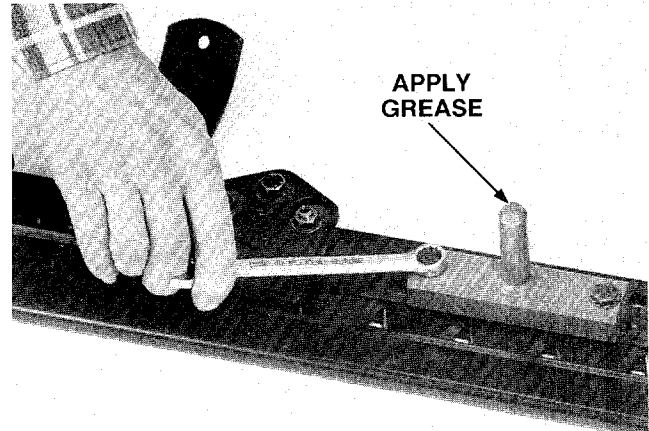

Photo 2-6: Installing the drive pin.

2. Grasp the drive pin with one hand. Steady the cutter bar with your other hand. Try to move the cutter blade from side to side. Occasionally dried paint will prevent the blade from moving. If you can't move the blade, rap the side of the drive pin with a rubber mallet to break the cutter blade free of the dried paint.
3. Place the drive socket on the drive pin. Place the cutter bar assembly in front of the mower's nose piece.
4. Lubricate the drive pin with multi-purpose grease.
5. Have an assistant push down on the handlebars to very slightly raise the nose of the mower.
6. Slowly slide the cutter bar assembly rearward. Make sure that: a) the cutter bar mount rests on top of the cutter bar and its four holes align with the four (square) holes in the cutter bar mount, and b) the shaft on the drive socket enters the hole in the front of the drive arm.
7. From underneath, insert a 5/16-18 x 1 1/4-inch carriage bolt up through one of the holes in the cutter bar. Loosely install a 5/16-18 nut on this bolt. Repeat

this for the remaining three holes. Then tighten all four nuts.

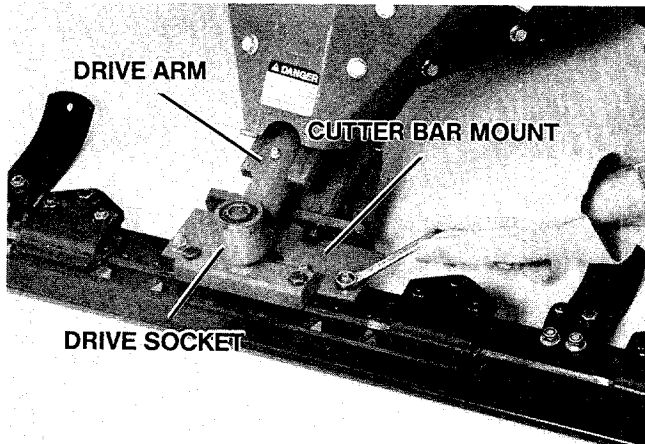

Photo 2-7: Installing the cutter bar assembly.

8. Place the forward (shorter) half of one of the height adjusters beneath the rear of the cutter bar. Make sure that the "hump" on the height adjuster faces up. Align the two holes in this half of the height adjuster with the two holes in the rear of the cutter bar. See Photo 2-8.

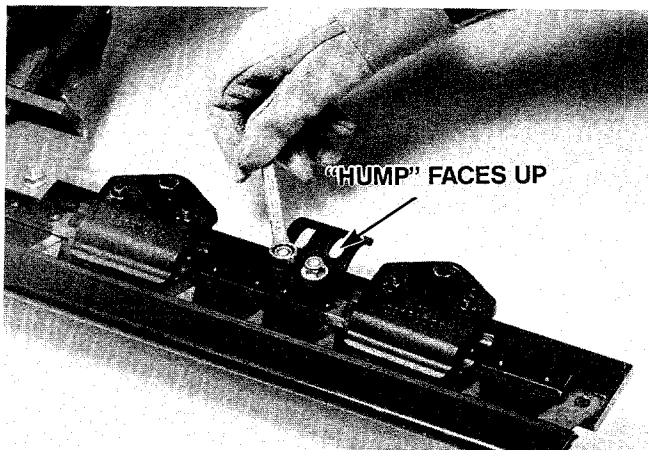

Photo 2-8: Installing the forward half of the height adjuster.

9. From underneath, insert two 8MM x 30MM carriage bolts up through the holes in the height adjuster and blade. Place an 8MM flat washer and an 8MM lock nut on each of these carriage bolts. Use a 13MM (or a 1/2-inch) wrench to evenly and securely tighten both of these nuts.

NOTE

Use care to not use the 5/16-18 nuts on the 8MM carriage bolts. Although it is possible to make them fit, you will ruin the bolt.

10. Place the rear (longer) half of the height adjuster (again, with its "hump" facing up) beneath the forward half of the height adjuster.

11. From underneath, insert a U-bolt through the two holes in the height adjuster halves. Place a flat washer and a locknut on each of the threaded ends of the U-bolt. Use a 1/2 inch wrench to evenly tighten the nuts.

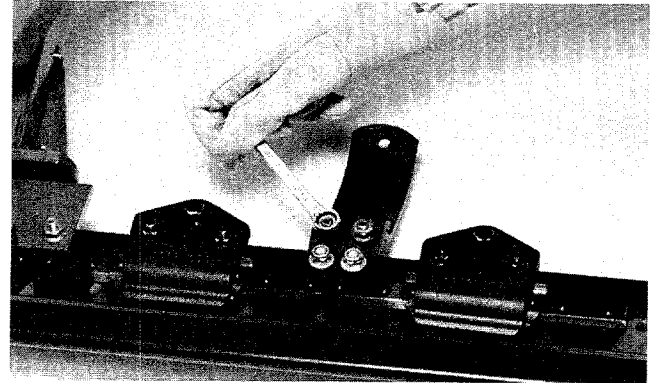

Photo 2-9: Installing the rear half of the height adjuster.

12. Repeat Steps 8 through 11 for the remaining side of the cutter bar and height adjuster halves.

13. Have your assistant lower the nose of the mower.

NOTE

To adjust the height adjusters for blade cutting height, please refer to "Cutting Height Adjusters" in Section 3 of this Manual.

Step 5: Attach the Tie Straps (Standard Start Models Only)

NOTE

If you have an electric start model, the tie straps will be installed in Step 9.

1. On the right-hand handlebar, loop a tie strap (serrated side faces in) around the handlebar, the blade drive lever control cable and the throttle cable. Make sure that the strap is located ABOVE the adjuster assembly on the control cable. See Figure 2-10. Tighten the strap and trim off any excess length.

2. Use a second tie to attach the wheel drive lever control cable to the left-hand handlebar. Again, make sure that the strap is located ABOVE the adjuster assembly on the cable.

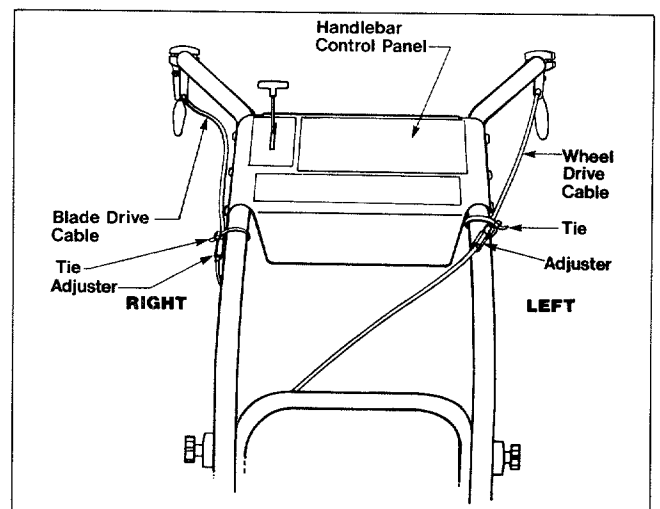

Figure 2-10: Attaching the tie straps (standard start models only).

EASY ASSEMBLY

Step 6: Add Oil to the Engine

1. Push the mower to a level area.
2. Unscrew the dipstick from the engine. Wipe the dipstick clean.
3. Insert a clean funnel into the oil fill tube as shown in Photo 2-11.
4. Pour the oil into the engine. The engine will hold approximately 1¼ pints. See Photo 2-11.

NOTE

Please refer to "Specifications" on the inside rear cover of this Manual to determine the type of oil to add to the engine.

5. Remove the funnel. Screw the dipstick back into the oil fill tube. Unscrew the dipstick and check the oil level. It should be up to the FULL mark on the dipstick.

If it is not up to this level, re-insert the funnel into the oil fill tube. Then slowly add more oil until the oil level is correct. While you're adding the oil, frequently pause and check the oil level with the dipstick to prevent overfilling.

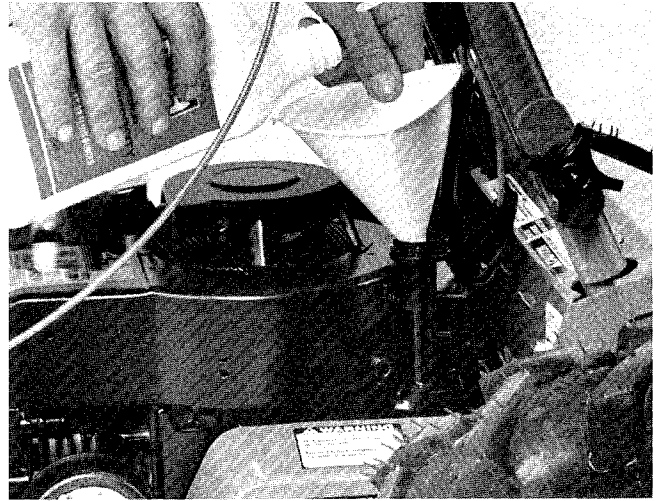

Photo 2-11: Adding oil to the engine.

Step 7: Check Tire Air Pressure

Use an automotive-type tire pressure gauge to check the air pressure in both tires. The tires may have been over-inflated for shipping purposes. Make sure that the air pressure in both tires is the same or the mower could pull to one side. The correct tire pressure is from 10 to 20 pounds per square inch (PSI).

If you have a standard start TRAIL BLAZER® Mower, you have now finished assembling it. Before you begin operation, review Section 1: Safety, and read Sections 3 and 4 to make sure that you know how to properly and safely operate your new mower.

If you have an electric start TRAIL BLAZER® Mower, you will have a few additional assembly steps to complete to assemble some of the electric starting system parts on the mower. Please go on to these following steps.

Step 8: Installing the Keyswitch

1. Unscrew the large nut off the keyswitch. Remove the large toothed lockwasher from the keyswitch.
2. From underneath the mower's control panel, insert the threaded end of the keyswitch into the hole in the rear of the control panel. (The hole for the keyswitch is marked "ENGINE IGNITION".)
3. Place the large toothed lockwasher back onto the keyswitch. Reinstall the nut on the keyswitch. Use a 13/16-inch wrench (or a large adjustable wrench) to securely tighten the nut.

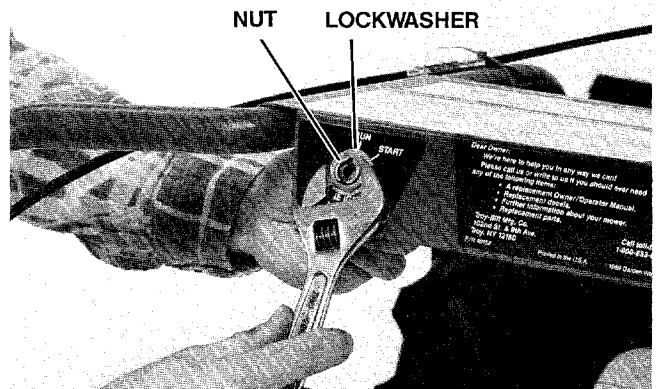

Photo 2-12: Installing the keyswitch.

Step 9: Connecting the Wiring Harness

1. Unwrap the wiring harness from the mower.
2. Route the wiring harness beneath the left-hand handlebar tube. Plug the connector at the top of the wiring harness into the back of the keyswitch. (You can attach the connector to the two keyswitch terminals either way.)
3. For now, leave the plug on the lower end of the wiring harness disconnected. You'll connect it later, after you've charged the battery.

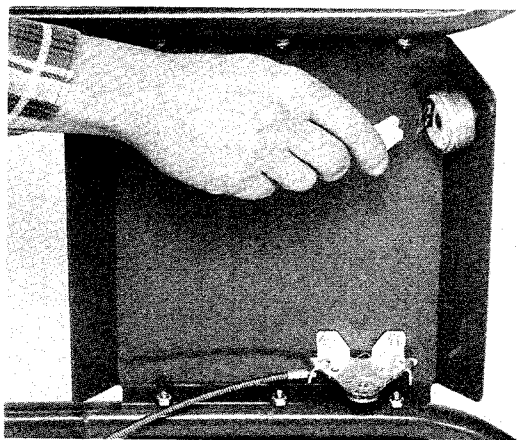

Photo 2-13: Attaching the Wiring Harness to the Keyswitch.

4. Insert the narrow plastic tie strap into the hole in the bracket that is located on the front part of the engine housing (to the left of the oil fill tube). See Figure 2-14.

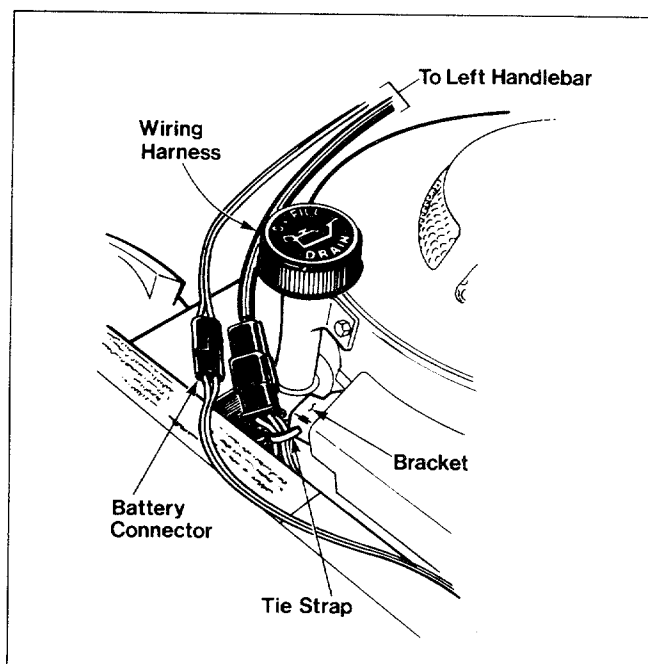

Figure 2-14: Secure the lower end of the wiring harness to the engine bracket (electric start models).

5. Move the lower part of the wiring harness to the right and secure it to the engine's bracket with the tie strap as shown in Figure 2-14. Make sure that the large connector on the wiring harness is ABOVE the tie strap. Be certain that the battery connector wires are NOT secured to the engine's bracket with the tie strap.
6. Secure the upper part of the wiring harness to the left-hand handlebar tube (above the lock clamp) with a wide tie strap as shown in Figure 2-15. Make sure that the serrated side of the strap faces in when you loop it around the handlebar. After tightening the strap, snip off any excess length.
7. Use another wide tie strap to secure the Wheel Drive Cable and the wiring harness to the left-hand handlebar tube below the handlebar's control panel as shown in Figure 2-15. Make sure that the tie strap is located ABOVE the cable adjuster.
8. Use another wide tie strap to secure the Blade Drive Cable and the throttle cable to the right-hand handlebar tube as shown in Figure 2-15. Make sure that the tie strap is located ABOVE the cable adjuster.

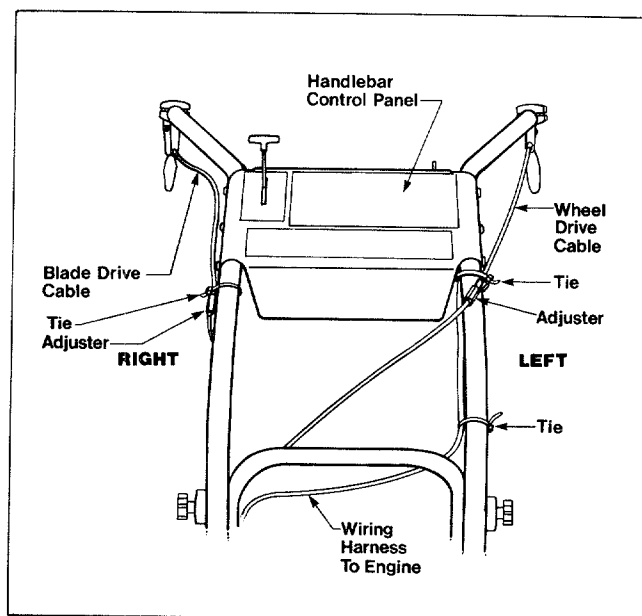

Figure 2-15: Attaching the tie straps (electric start models).

Step 10: Charge the Battery

Charge the mower's battery by following the battery charging instructions given on Page 40 of this Manual.

After you've charged the battery, you've finished assembling the mower. **Before operating the mower, be sure to review Section 1: Safety, and read Sections 3 and 4 to make sure that you know how to properly and safely operate your new mower.**



SECTION 3: ENGINE AND MOWER CONTROLS

This Section shows the location and describes the function of the various mower and engine controls you will need to use when operating the mower.

After reading this Section and familiarizing yourself with the various controls, please refer to "Section 4: Operation" for step-by-step engine starting and mower operation instructions.

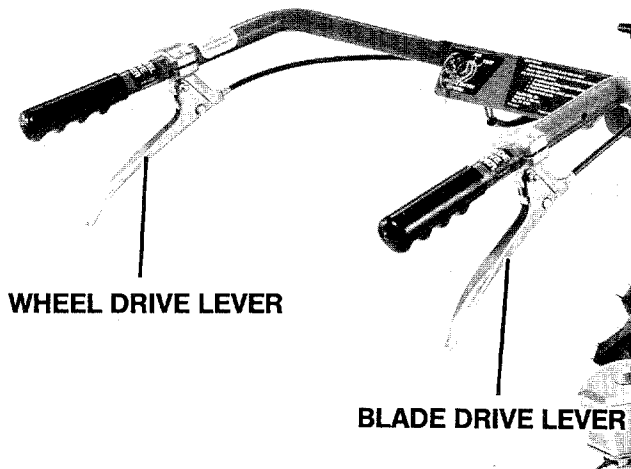

Photo 3-1: The handlebar control levers.

Blade Drive Lever

This lever is located beneath the right-hand handlebar grip. To operate the cutter bar (when the engine is running) you simply rest your right hand on the right-hand handlebar grip and squeeze the lever upward. The cutter bar will begin oscillating (moving back and forth) and will continue to do so as long as you are squeezing the Blade Drive Lever.

To stop the cutter bar from oscillating, simply release the Blade Drive Lever.

Wheel Drive Lever

This lever is located beneath the left-hand handlebar grip. To make the mower's wheels turn (when the engine is running) you simply rest your left hand on the left-hand handlebar grip and squeeze the lever upward. The wheels will begin turning and will continue to turn as long as you are squeezing the Wheel Drive Lever.

To stop the wheels from turning, simply release the Wheel Drive Lever.

⚠ WARNING

If the wheels do not stop turning when you release the Wheel Drive Lever, shut the mower's engine off, wait until the engine cools, disconnect the spark plug wire and prevent it from touching the spark plug. Do not use the mower until the wheel drive mechanism is repaired so that the wheels stop turning when the Wheel Drive Lever is released. See "Wheel Drive Adjustment (General)" in Section 5 of this Manual.

Failure to do so could result in personal injury or property damage.

⚠ DANGER

If the cutter bar does not stop oscillating when you release the Blade Drive Lever, or if it oscillates before you squeeze this lever, shut the mower's engine off, wait until it cools, disconnect the spark plug wire and prevent it from touching the spark plug. Do not use the mower until the cutter bar drive mechanism is repaired so that the cutter bar stops oscillating when the Blade Drive Lever is released. See "Cutter Bar Drive Adjustment (General)" in Section 5 of this Manual.

Failure to follow this instruction could result in personal injury or property damage.

Cutting Height Adjusters

There are two cutting height adjusters, one on each side of the rear end of the cutter bar. These adjusters are used to raise or lower the blade's cutting height. You can adjust the blade's cutting height from approximately 1¼-inch to 5-inches.

To prevent excessive wear on the blade, set both height adjusters so that the blade is raised off the ground and will not dig into the ground.

To change the cutter bar's cutting height:

CAUTION

Before changing the cutter bar's cutting height, shut the engine off, disconnect the spark plug wire and prevent it from touching the spark plug, and reinstall the plastic blade protector on the front of the cutter bar. On electric start models, also remove the Engine Ignition key from the keyswitch.

Failure to do so could result in personal injury or property damage.

1. Move the mower to a flat area such as a paved driveway or a garage floor.
2. Use a 13 MM wrench (or a ½-inch or an adjustable wrench) to loosen the two nuts that hold the halves of the height adjusters together.
3. Move the rear half of the height adjuster rearward to raise the cutting height. Move the rear half of the height adjuster forward to lower the cutting height.

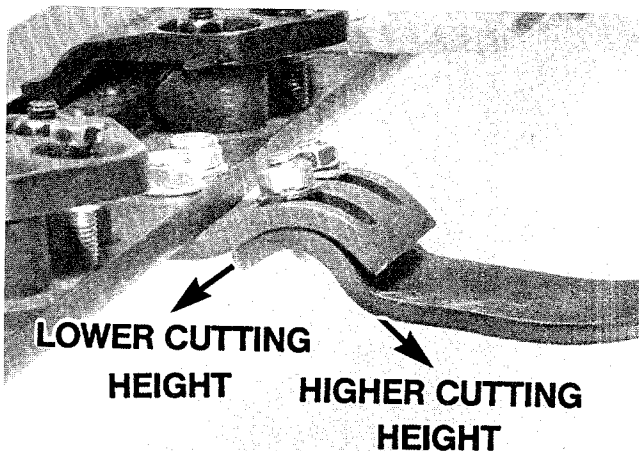

Photo 3-2: Adjusting the blade height.

4. Hold the rear half of the height adjuster in place while you tighten the two nuts that you loosened in Step 2.
5. Repeat Steps 1 through 4 for the height adjuster on the other side of the cutter bar. Visually check the blade to make sure it is parallel to the driveway or garage floor. Otherwise the cutting height will be uneven and you'll get a sloping cut when you mow.

Handlebar Height Adjustment

You can adjust the handlebars on your mower to either of two positions. The lower handlebar height is approximately 36 inches high and the higher handlebar height is approximately 38 inches high.

NOTE

The lower handlebars are rubber mounted at their lower end (to help reduce vibration to the operator). This may make them feel somewhat loose, however this is normal.

To adjust the handlebar height:

CAUTION

Before adjusting the handlebar height, shut the engine off, allow it to cool, disconnect the spark plug wire and prevent it from touching the spark plug. For electric start models, also remove the Engine Ignition key from the keyswitch.

Failure to do so could result in personal injury or property damage.

1. Unscrew the handlebar knobs from both sides of the lower handlebars. Then remove the lockwashers and handlebar lock clamps.
2. Remove one of the handlebar bolts by pushing it inward.
3. Use one hand to hold the upper handlebars while you push the remaining handlebar bolt inward all the way.
4. Slide the upper handlebars up or down to align the holes in their ends with the holes in the lower handlebar.
5. Reinstall the two handlebar bolts, two handlebar lock clamps, and the two lockwashers.
6. Place the two handlebar knobs on the handlebar bolts and very securely tighten them.

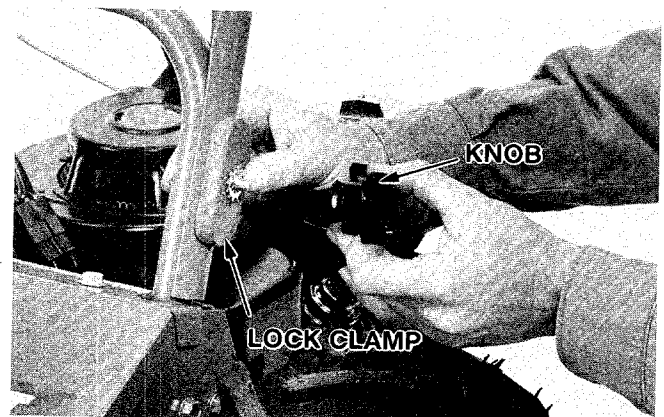

Photo 3-3: Adjusting the handlebar height.

ENGINE CONTROLS

Engine Throttle Lever

The Engine Throttle Lever is attached to the right-hand side of the handlebar control panel. This lever controls the speed of the engine (which in turn controls the speed of both the cutter bar and the wheels when you have those handlebar levers engaged).

Moving the Engine Throttle Lever forward increases the engine speed. Moving the Engine Throttle Lever rearward decreases the engine speed. Moving it all the way to the rear (to its STOP position) will shut the engine off.

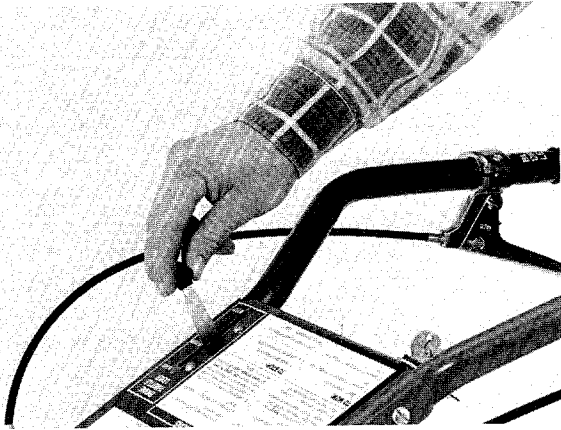

Photo 3-4: The Engine Throttle Lever.

Engine Choke

The engine on your mower does not have a separate manually operated choke lever. The START position of the Engine Throttle Lever automatically sets the choke on the engine's carburetor.

Recoil Starter

The recoil starter rope is located on top of the engine. It is used to "pull-start" the engine. To use the recoil starter rope, stand in back of the mower and place your left hand on the left handlebar (to stabilize the mower while you pull the recoil starter rope). Grasp the black plastic starter rope handle with your right hand, and slowly pull the rope until you feel some resistance. Then rapidly pull the rope to start the engine.

If you have an electric start mower, you can also use the recoil starter rope to start the engine if the electric starting system should malfunction. You can start the electric start mower with the recoil starter rope regardless of whether or not the Engine Ignition key is in the keyswitch. [Please refer to "Engine Ignition Switch (Electric Start Models)" in this Section for additional information.]

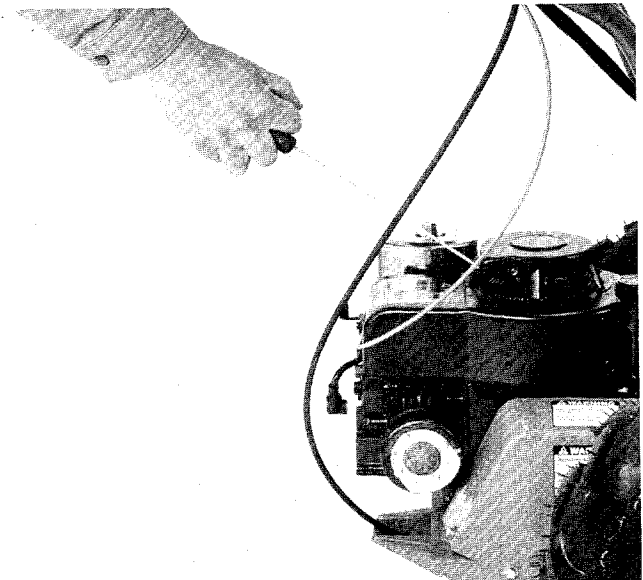

Photo 3-5: Starting the engine with the recoil starter rope.

Engine Ignition Switch (Electric Start Models Only)

The Engine Ignition Switch is located on the left hand side of the rear lip of the handlebar control panel. This switch enables you to easily start your mower's engine by simply turning the key to the START position. When the engine starts, release the key and it will automatically return to the RUN position.

The Engine Ignition key will not shut the mower engine off. Use the Engine Throttle Lever to stop the engine.

NOTE

You can use the recoil starter rope to start the engine on your electric start mower. It doesn't matter if the Engine Ignition key is in the keyswitch or not.

SECTION 4: MOWER OPERATION

This Section of the Manual provides step-by-step starting and operating procedures. Before you start your mower's engine, please review all of the Safety Instructions given in "Section 1: Safety".

When first operating the mower, it is a good idea to practice using it on a clear, level area. This way you'll

comfortably familiarize yourself with the location and operation of all the mower's controls.

If you should ever lend your mower to another person, please lend him or her this Manual to read. Make sure that he or she knows how to safely operate, and quickly stop the mower.

Filling the Engine's Gas Tank

Use clean, fresh lead-free gasoline which has a minimum octane rating of 77.

Do not add any type of oil to the gas.

⚠ DANGER

Gasoline and its fumes are highly flammable.

Before filling the gas tank, shut the engine off, allow it to cool, disconnect the spark plug wire and prevent it from touching the spark plug. On electric start models, also remove the Engine Ignition key from the keyswitch.

Failure to do so could result in personal injury or property damage.



Photo 4-1: Filling the gas tank.

To add gas to the mower's gas tank:

1. Unscrew the cap from the gas tank.
2. Insert a clean funnel into the gas tank (or use a fuel container that has a flexible pour spout).
3. Very slowly pour gas into the tank. Pause frequently while you're pouring, remove the funnel, and check the level of the gas in the gas tank. Do not fill the gas tank to the point of overflowing—allow some air space in the gas tank for the gas to expand.
4. Securely reinstall the gas tank cap.
5. Wipe any spilled gas off the mower before you start the engine.

⚠ CAUTION

- Check the gas level in the mower's gas tank before starting the engine.
- Do not fill the gas tank indoors, when the engine is running, or when the engine is hot. Allow the engine to cool for several minutes before filling the gas tank.
- Reinstall the gas tank cap securely, and clean up any spilled gas before starting the engine.
- Keep gas and its vapors away from all sources of sparks and flame.
- Move the mower away from gas fumes before starting the engine.
- Never run the engine indoors; always run the engine outdoors and make sure there is adequate ventilation.

Failure to follow these instructions could result in personal injury or property damage.

OPERATION

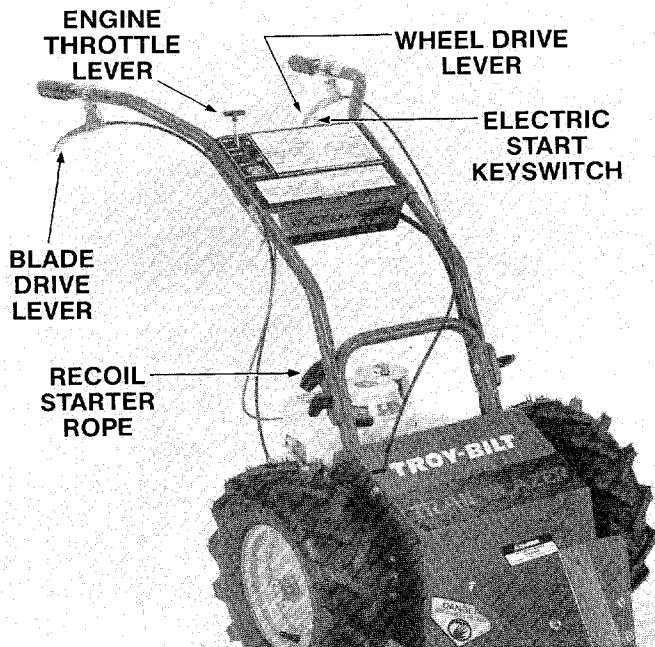

Photo 4-1: Mower Controls.

Starting the Mower

WARNING

Do not operate the mower when children or others are around.

Failure to follow this instruction could result in personal injury or property damage.

1. Before starting the mower, thoroughly inspect the area where you'll be using the mower. Remove all metal debris and other hazards from this area. Also inspect this area for hidden hazards, holes, ruts, or bumps.
2. Before you start the mower's engine, be sure to perform the following pre-start checklist:
 - a. Check to make sure that there is gas in the mower's gas tank. See Page 15 for gas tank filling instructions and safety cautions.
 - b. Check the engine oil level.
 - c. Check the spark arrester screen (on the muffler) for looseness and damage.

WARNING

Avoid fires due to sparks.

Do not operate engine if spark arrester screen is loose or damaged.

- d. Make sure that both handlebar levers are not engaged (make sure that they are released).

- e. Check to make sure the blade cutting height is adjusted to the desired cutting height.
- f. Remove the plastic cutter bar protector from the front of the blade.
- g. Reconnect the spark plug wire to the spark plug.

3. Start the engine as follows:

For electric start engines:

- a. Stand behind the mower in the operator's position.
- b. Move the Engine Throttle Lever to START.
- c. Grasp the right-hand handlebar grip with your right hand.
- d. Turn the Engine Ignition key to START.

NOTE

Do not continuously crank the engine with the Engine Ignition key. Use the key only for 15 seconds. If the engine doesn't start, allow it to rest for 45 seconds before again trying to start the engine.

- e. When the engine starts, release the key. It will automatically return to its RUN position.

For standard start engines:

- a. Stand behind the mower in the operator's position. (See Photo 3-5 on Page 14.)
- b. Move the Engine Throttle Lever to START.
- c. Place your left hand on the left handlebar to stabilize the mower when you pull the recoil starter rope.
- d. Grasp the black plastic starter rope handle with your right hand. Slowly pull the rope until you feel some resistance. Then rapidly pull the rope to start the engine. Repeat this step as necessary until the engine starts.

Mowing

1. Stand behind the mower in the operator's position and place both hands on the handlebar grips.
2. To engage the cutter bar drive, squeeze the right-hand handlebar lever (the Blade Drive Lever). The cutter bar blade should begin to oscillate (move from side to side) rapidly.
3. To make sure that the cutter bar drive mechanism is working correctly, release the right-hand handlebar lever. The cutter bar blade should stop oscillating.

⚠ DANGER

If the cutter bar does not stop oscillating when you release the Blade Drive Lever, or if it oscillates before you squeeze this lever, shut the mower's engine off, wait until it cools, disconnect the spark plug wire and prevent it from touching the spark plug. Do not use the mower until the cutter bar drive mechanism is repaired so that the cutter bar stops oscillating when the Blade Drive Lever is released. See "Cutter Bar Drive Adjustment (General)" in Section 5 of this Manual.

Failure to follow this instruction could result in personal injury or property damage.

4. To engage the wheel drive, squeeze the left-hand handlebar lever (the Wheel Drive Lever). The wheels should begin turning.
5. To make sure that the wheel drive mechanism is working correctly, release the left-hand handlebar lever. The wheels should stop turning.

⚠ WARNING

If the wheels do not stop turning when you release the Wheel Drive Lever, shut the mower's engine off, wait until the engine cools, disconnect the spark plug wire and prevent it from touching the spark plug. Do not use the mower until the wheel drive mechanism is repaired so that the wheels stop turning when the Wheel Drive Lever is released. See "Wheel Drive Adjustment (General)".

Failure to do so could result in personal injury or property damage.

6. If both the cutter bar drive mechanism and the wheel drive mechanism are operating correctly, re-engage the lever(s).

NOTE

If you only want to move the mower (and not mow), don't engage the Blade Drive Lever, just engage the Wheel Drive Lever.

Stopping

To stop the mower:

1. Release both handlebar levers (this will stop the wheels and cutter bar).
2. Move the engine throttle lever to STOP (to stop the engine).
3. After the engine cools, disconnect the spark plug wire from the spark plug. Prevent it from touching the spark plug by placing the boot on the end of the spark plug wire onto the V-shaped holder on the back of the engine (see Page 5).
4. Reinstall the plastic blade protector on the cutter bar.

General Mowing Tips

1. Before mowing, be sure to inspect the area thoroughly. Remove all metal debris and other hazards. Remember that tall grass or vegetation can hide these hazards. Also note the location of any hidden obstacles, such as gullies or brush-covered posts, holes, bumps, etc.
2. If the area to be mowed has small trees, it is best to saw down any that are over ½-inch in diameter. Make sure that the trees are sawed off low enough so that the mower's blade won't catch on them. This will prevent excessive cutter bar wear or blade breakage.
3. If the blade should clog, release the handlebar levers, pull the mower rearward for a few feet, push down on the handlebars so that the blade is raised slightly off the ground, and re-engage the Blade Drive Lever. This should "shake" any excess material off the cutter bar. Then you can go forward and resume mowing. Never unclog any part of the mower with your hands or feet when the engine is running.
4. If you should accidentally hit an object that stops the forward motion of the mower, immediately disengage (release) the Wheel Drive Lever to help prevent any damage to the wheel drive mechanism.
5. If taller vegetation tends to wrap around the mower between the wheels and the side frame, shut the engine off and remove the vegetation by referring to "Removing and Reinstalling the Wheels". After removing this excess vegetation, check to make sure that both weed guards are in place between the rear inner surface of the tires and the engine deck.

SECTION 5: MAINTENANCE

Engine Maintenance

Checking the Engine Oil Level and Adding Oil to the Engine

Before starting the mower's engine, check its oil level. If you run the engine while it's low on oil, you risk causing damage to the engine. While mowing, frequently stop the engine and check its oil level (at least every 5 hours of operation).

If you're mowing slopes, the oil can slant away from internal engine parts, so it is extremely important to keep the oil level correct. While mowing slopes, check the engine oil level every 30 minutes of operation and keep the oil level up to the FULL mark on the dipstick. (Be sure to move the mower to a flat area before checking the engine oil level.)

To check the engine oil level:

CAUTION

Before checking the engine oil level, shut the mower's engine off, allow the engine to cool, disconnect the spark plug wire and prevent it from touching the spark plug. For electric start models, also remove the Engine Ignition key from the keyswitch.

Failure to do this could result in personal injury or property damage.

1. Move the mower to a level area.
2. Shut the engine off.
3. Clean any debris away from the area around the oil dipstick so that no debris can fall into the engine when the dipstick is removed.
4. Unscrew the dipstick and use a clean, lint-free rag to wipe the dipstick clean.

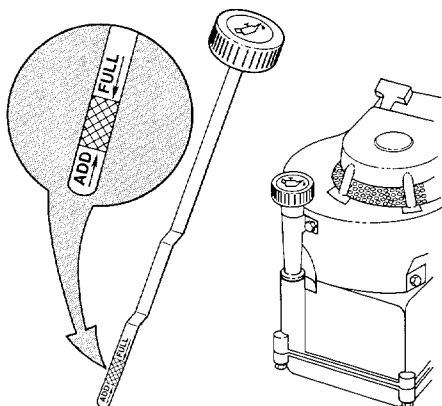

18 **Figure 5-1: Checking the engine oil level.**

5. Firmly screw the dipstick all the way back into the oil filler tube.

6. Unscrew the dipstick and check the engine oil level. The level should be between the ADD and the FULL marks on the dipstick.

7. If you have to add oil to the engine, please use the following instructions:

- a. Insert a clean funnel into the oil filler tube.
- b. Select a clean, high-quality detergent oil using the viscosity and temperature recommendations given in "Specifications" on the inside rear cover of this Manual.
- c. Slowly pour the oil into the funnel, pausing frequently to check the engine oil level with the dipstick (see the previous instructions).

NOTE

DO NOT overfill the engine with oil. Overfilling the engine with oil could make the engine smoke excessively or appear to be seized.

d. When the engine oil level is correct, securely reinstall the dipstick.

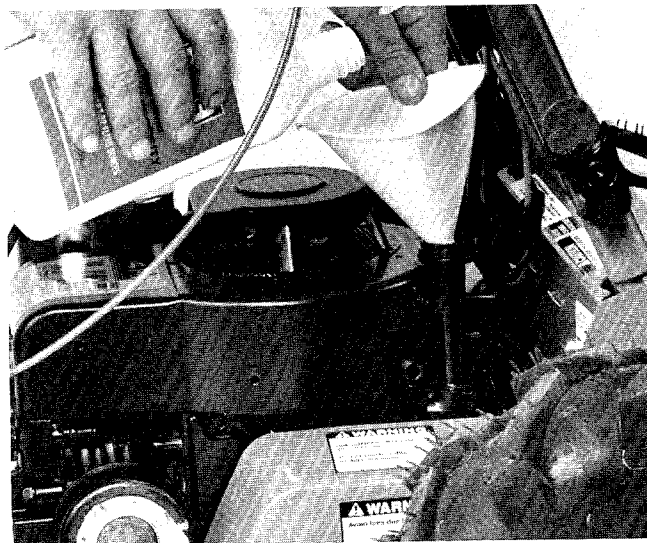

Photo 5-2: Adding oil to the engine.

Changing the Engine Oil

After the very first five hours that you operate your new mower, change the engine oil. Thereafter, change the engine oil every twenty-five hours of operation. If you operate your mower in very dusty or dirty conditions, change the engine oil even more frequently.

Use the following instructions when changing the engine oil:

1. Run the mower engine until it is warm. Then SHUT THE ENGINE OFF.

⚠ CAUTION

Before changing the engine oil, shut the engine off, disconnect the spark plug wire and prevent it from touching the spark plug. For electric start models, also remove the Engine Ignition key from the keyswitch.

Failure to do this could result in personal injury or property damage.

2. Place a drain pan with a minimum capacity of 2 quarts beneath the engine's drain plug.
3. Use a pair of pliers to firmly grip the engine oil drain tube as shown in Photo 5-3. This prevents the drain tube from accidentally being unscrewed from the base of the engine when you remove the drain plug in the next step.
4. Use a 13/16-inch wrench (or a large adjustable wrench) to unscrew the drain plug from the drain tube. See Photo 5-3.

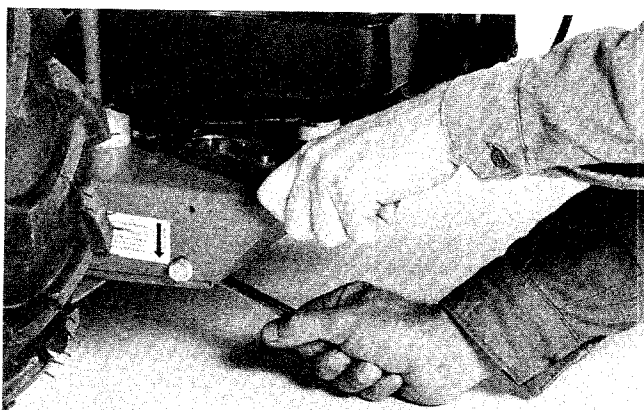

Photo 5-3: Draining the engine oil.

5. Allow all of the old oil to flow out of the engine.
6. Again grip the drain tube with the pliers and reinstall the drain plug on the oil drain tube. Very securely tighten the drain plug.
7. Refill the engine with fresh oil. See "Checking the Oil Level and Adding Oil to the Engine" on Page 18 for specific instructions.

Air Cleaner Maintenance

The engine on your mower uses one of two types of air filters. The 3½-horsepower engine has a single element oil foam air cleaner. The 4-horsepower engine has a dual element air cleaner (a replaceable paper cartridge with an oiled foam pre-cleaner).

Before each use, always make sure that the air cleaner is securely attached to the engine. A loose or ill-fitting air cleaner assembly could allow dust or dirt into the engine. This could shorten the life of the engine.

Every 25 hours of engine operation (more frequently if operating the mower in a very dusty or dirty environment) clean and inspect the engine's air cleaner element(s).

To service the 3½-horsepower engine air cleaner:

1. Clean any excess dirt, dust, or chaff off the air cleaner.
2. Remove the screw that secures the air cleaner assembly to the engine. Lift the air cleaner assembly up, off the engine.
3. Separate the body halves of the air cleaner assembly and remove the foam element.
4. Clean this foam element as follows:
 - a. Thoroughly wash the element in a solution of liquid detergent and water.
 - b. Wrap the element in a clean towel and squeeze it dry.
 - c. Apply clean engine oil to the ends and sides of the foam element. Knead the foam element to evenly distribute the oil.
 - d. Squeeze any excess oil out of the foam element.
5. Thoroughly clean both halves of the air cleaner body.
6. Reinstall the foam element in the bottom half of the body.
7. Place the air cleaner's cup into the foam element as shown in Figure 5-4.
8. Place the top half of the body onto the bottom half. Insert the screw into the top half of the air cleaner and reinstall the air cleaner assembly onto the engine.

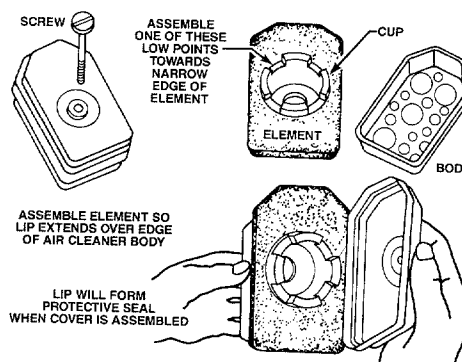
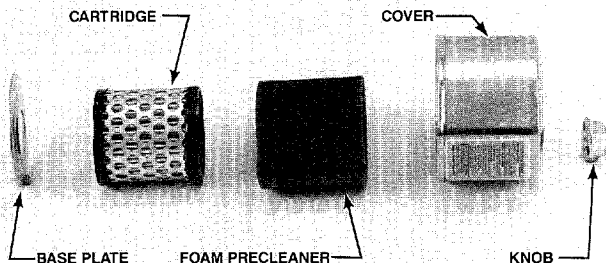

Figure 5-4: The 3½-horsepower engine's air cleaner assembly.

MAINTENANCE

To service the 4-horsepower engine air cleaner:

1. Clean any excess dirt, dust, or chaff from the air cleaner and carburetor.
2. Unscrew the knob from the top of the air cleaner and lift the cover off.
3. Remove the foam pre-cleaner by sliding it upward, off the paper cartridge.
4. Unscrew the wing nut from the stud in the center of the paper filter. Lift the cartridge and base plate up, off the stud.
5. Clean the foam pre-cleaner as follows:
 - a. Wash it in a solution of warm water and non-sudsing detergent.
 - b. Wrap it in a towel and squeeze it dry.
 - c. Apply clean engine oil to it and then knead it to evenly distribute the oil. Squeeze any excess oil out of the pre-cleaner.
6. Clean the paper cartridge by tapping it on a flat surface to remove any loose dirt. If the cartridge is very dirty, either replace it with a new one or wash it in a solution of low- or non-sudsing detergent and warm water. Then rinse the cartridge thoroughly from the inside out until the water flowing through the cartridge is clear. Allow the cartridge to dry very thoroughly before reinstalling it.
7. Clean the base plate and the inside of the air cleaner cover.
8. Place the base plate over the stud. Then place the paper cartridge over the stud and secure it in place with the wing nut.
9. Slide the foam pre-cleaner down over the cartridge.
10. Place the cover over the stud. Secure the cover in place with the knob.



20 **Photo 5-5: The 4-horsepower engine's air cleaner assembly.**

Spark Arrester

The muffler on the mower's engine is equipped with a screen-type spark arrester to help keep stray sparks from accidentally escaping.

Before each use, check the spark arrester for looseness and damage. If the spark arrester is damaged or missing, do not use the mower until the spark arrester is replaced with an original-equipment spark arrester (available from us or your local Briggs & Stratton dealer).

⚠ WARNING

Avoid fires due to sparks.

Do not operate engine if spark arrester screen is loose or damaged.

⚠ WARNING TO ALL CALIFORNIA MOWER OPERATORS

Under California Law, you are not permitted to operate an internal combustion engine using hydrocarbon fuels on any forest-covered, brush-covered, or grass-covered land, or land covered with grain, hay, or other flammable agricultural crop, without an engine spark arrester in continuous effective working order. The engine on your mower, like most lawn or garden equipment, is an internal combustion engine that burns gasoline (a hydrocarbon fuel); therefore it must be equipped with a spark arrester muffler in proper working order. The spark arrester must be attached to the engine exhaust system in such a manner that flames or heat from the system will not ignite flammable material. Failure of the operator to comply with this regulation is a misdemeanor under California Law. Other states may have similar laws. Federal laws apply on Federal lands.

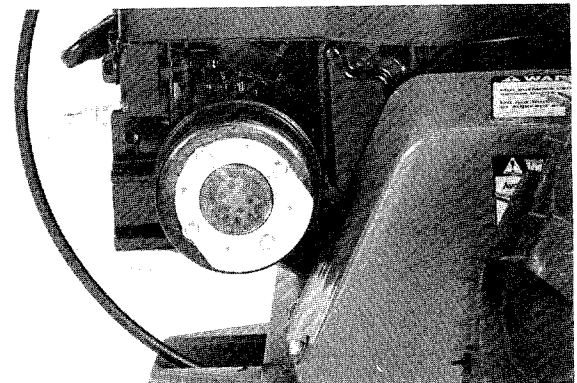

Photo 5-6: The engine spark arrester.

Also, please refer to the Briggs & Stratton Operating and Maintenance Instructions Manual for periodic spark arrester maintenance information.

Air Cooling System Maintenance

As you mow, dry grass or chaff can clog the engine's cooling fins and shrouds. Clean any debris from the engine as often as needed to avoid engine overheating and damage.

If the accumulation of debris and dirt is especially heavy, it may be necessary to remove the engine shroud every few hours and clean the engine parts located beneath the shroud. When removing and replacing the engine shroud, be very careful not to bend or damage the governor vanes, linkages, or any wires.

After approximately 100 hours of engine operation (more often if necessary), take the mower to an Authorized Briggs & Stratton Service Center so that its cooling fins and shrouds can be properly cleaned. This will help prevent engine overspeeding, overheating, or other damage.

Carburetor Adjustment (Engine Speed & Mixture)

We have adjusted the carburetor on your mower's engine to give you the best possible performance from your mower.

The rated speed for the engine is 3100 RPM to 3300 RPM. Do not attempt to make any adjustments to the carburetor that would allow the engine to exceed this speed. The idle speed for the engine is 1750 RPM.

If you believe that the engine's carburetor is out of adjustment, please refer to the Briggs & Stratton Operating and Maintenance Instructions Manual for the correct procedure for carburetor adjustments.

Engine Ignition System

Your mower's engine is equipped with an electronic ignition system. This type of system eliminates the traditional set of points and condenser. With this newer type of electronic ignition system, you no longer have to perform any scheduled ignition system maintenance (other than cleaning or replacing the spark plug as discussed next).

If you ever suspect that the engine's ignition system is malfunctioning, contact an Authorized Briggs & Stratton Service Center for repairs.

Spark Plug

Every 100 hours of engine operation you should remove, clean, and inspect (or simply replace) the spark plug.

Inspect the spark plug for stripped threads, excessive combustion deposits on the electrodes and the interior of the spark plug, cracked porcelain, or other damage. If the spark plug is damaged, replace it. Refer to "Specifications" on the inside back cover of this Manual for replacement types of spark plugs.

Whenever you clean a spark plug, don't blast clean it. Scrape it or wire brush it clean.

After you clean and inspect an old spark plug, or if you are installing a new spark plug, be sure to set the gap to 0.030 inch.

Liquid Lock

When a vertical crankshaft engine (such as on your mower) is tipped so that the spark plug points downward for several hours, there is a chance that oil can leak into the space between the top of the piston and the cylinder head. If the piston is on its compression stroke, the oil can prevent it from moving. This situation is called "liquid lock", because the oil isn't compressible and it "locks" up the engine.

You will notice when you have an engine in this condition. You will be able to pull the recoil starter rope out only a short distance. Then you won't be able to pull it out any farther. If you're using the Engine Ignition key to try to start the engine and you think the engine is locked up, don't turn the key to start until you've cleared the engine as follows, or you could damage the starter.

Liquid lock is corrected as follows:

1. Remove the spark plug from the cylinder.
2. Slowly pull the recoil starter rope by hand until no more oil comes out of the spark plug hole.
3. Thoroughly clean the spark plug. Reinstall the spark plug. Reconnect the spark plug wire to the spark plug.
4. Check the engine oil level.
5. Again try to start the engine.



Mower Maintenance

Lubrication

Please refer to Photo 5-7 and the list of items that follow it to see which items on your mower should be lubricated. Keeping these items lubricated helps your mower to perform better.

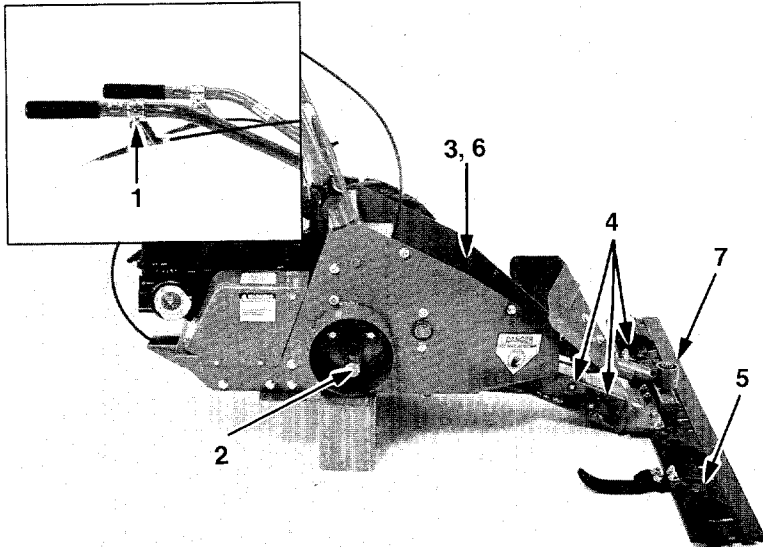

Photo 5-7: Mower lubrication points.

NOTES

- Use fresh automotive grease when grease is called for.
- Use clean automotive type oil when oiling the blade.

1. Lubricate the handlebar levers' pivot points—Approximately every 25 hours of mower operation (or if either handlebar lever should bind or if the lever's action should become rough) apply oil or a silicone spray to the pivot points of both handlebar levers. Use care not to get any lubricant on the levers, so that your fingers won't slip off the lever during operation.

2. Grease the wheel shaft and clevis pin—Whenever you remove the wheels (or every 25 hours of engine operation, whichever comes first), you should apply a thin coating of grease to both the wheel shaft and clevis pin. This helps prevent corrosion from forming and allows you to more easily remove the clevis pin and wheel.

3. Grease the back channel of the drive arm—Every 25 hours of engine operation, clean any dirt from the top of the flywheel and from the back channel of the drive arm. Disconnect the spark plug wire and rotate the flywheel by hand until the bearing is all the way forward in the back channel. (The hole in the flywheel will be underneath the drive arm.) Then use your finger to apply fresh grease to the inside of the back channel.

4. Grease the cutter bar mount and the drive arm—Every 25 hours of operation use a grease gun to apply grease to the three fittings shown in Photo 5-7. Each fitting will require four or five complete pumps with the grease gun to make sure that it is lubricated properly. This ensures that your blade will easily pivot to follow the contours of the land you're mowing. It also ensures that cutter bar removal will be easier.

5. Oil the cutter bar—Every 5 hours of operation you should liberally apply oil to the cutter bar. Liberally apply oil to all the friction points on the cutter bar blades, the blade guides, and the ledger bar. You can use a squirt-type oil can, or you can simply pour oil onto the cutter bar directly from the can.

6. Oil the jackshaft chain—Every 25 hours of operation use a squirt-type oil can to sparingly oil the jackshaft chain. Use care not to get any oil on the cutter bar drive belt.

7. Grease the drive pin—Every 10 hours of operation remove the drive socket and apply fresh grease to the drive pin.

Removing and Reinstalling the Wheels

The mower's wheels are secured to the wheel shaft by a clevis pin and a clinch pin. Removing the wheels is a simple matter. Occasionally, especially when you're mowing taller vegetation, you might find that this vegetation tends to wrap around the wheels. To remove this vegetation, take the wheel off by following the instructions below. Then pull the vegetation off and reinstall the wheel.

CAUTION

Before removing or reinstalling a wheel, shut the engine off, allow it to cool, disconnect the spark plug wire and prevent it from touching the spark plug, and reinstall the plastic blade protector on the front of the blade. For electric start models, also remove the Engine Ignition key from the key-switch.

Failure to do this could result in personal injury or property damage.

To remove a wheel:

1. Prop up the mower so that the wheel is supported off the ground. Do this by placing a 5 or 6-inch thick block of wood beneath the mower.



Photo 5-8: Removing the wheel.

2. Move the quick release pin's round wire bail over the wheel hub.
3. Insert your finger in the round wire bail. Pull the pin out of the wheel hub. A small twisting motion while you pull is helpful.
4. Carefully slide the wheel outward until it is off the wheel shaft.

NOTE

If you had a difficult time removing the clevis pin or the wheel, inspect the wheel shaft, clevis pin, and inside surface of the wheel hub for corrosion or dirt. Clean any dirt away from these areas. If there is any corrosion, use a fine grade of sandpaper to remove it. Then apply grease to the wheel shaft and clevis pin to prevent further corrosion and to make future wheel removal easier.

To reinstall the wheel:

1. Align the wheel hub with the wheel shaft and slide the wheel onto the wheel shaft.
2. Rotate the wheel on the wheel shaft until the holes in the wheel hub align with the hole in the wheel shaft.
3. Insert the quick release pin through these holes.
4. Move the quick release pin's round wire bail over the wheel hub.

Removing and Installing the Wheel Drive Belt

CAUTION

Before removing or installing the wheel drive belt, shut the engine off, allow it to cool, disconnect the spark plug wire and prevent it from touching the spark plug, and reinstall the plastic blade protector on the front of the blade. For electric start models, also remove the Engine Ignition key from the keyswitch.

Failure to do so could result in personal injury or property damage.

You'll need the following items to change the wheel drive belt:

1. A replacement **original** equipment wheel drive belt (if the old belt is bad).
2. (Recommended) A new 1½-inch long by 3/16-inch thick cotter pin.
3. Several 6-inch thick blocks of wood (used to raise both wheels off the ground).
4. Two ½-inch wrenches.
5. A 5/16-inch wrench.
6. A hammer.
7. A ¼-inch straight punch.
8. A 5/32- or 1/8-inch straight punch.
9. A pair of water pump or channel lock pliers.
10. A medium-sized flat tip screwdriver (long or medium length).
11. A soft-faced hammer may be needed.
12. A large straight punch may be needed.
13. Safety glasses or goggles.

MAINTENANCE

To remove the wheel drive belt:

1. Use the ½-inch wrench to remove the two bolts that attach the top of the hood to the rear hood. Then loosen the four bolts (two on each side) that attach the hood to the left and right frame plates. Lift the hood up, off the mower.



Photo 5-9: Removing the hood.

2. Remove the battery and battery bracket on electric start models.

3. Use the hammer and the ⅛- or 5/32-inch straight punch to drive the spool pin from the small sprocket on the left-hand side of the jackshaft.

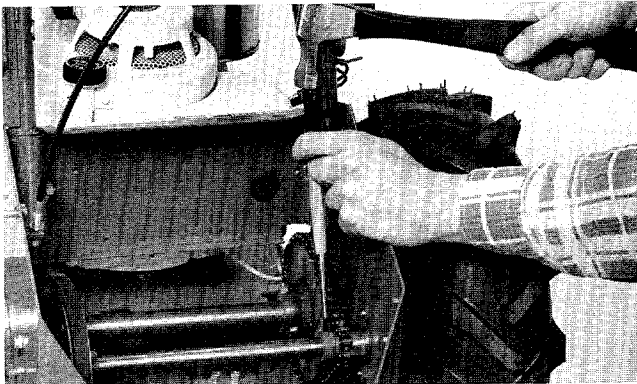

Photo 5-10: Removing the spool pin.

4. Place the wooden blocks beneath the mower so that both wheels are raised off the ground.

5. Use the two ½-inch wrenches to remove the nut and bolt that secures the large sprocket to the wheel shaft. (If the bolt seems to be stuck in place, use the large straight punch and hammer to gently drive the bolt out of the hole—remember, don't hammer the threaded part of the bolt.)

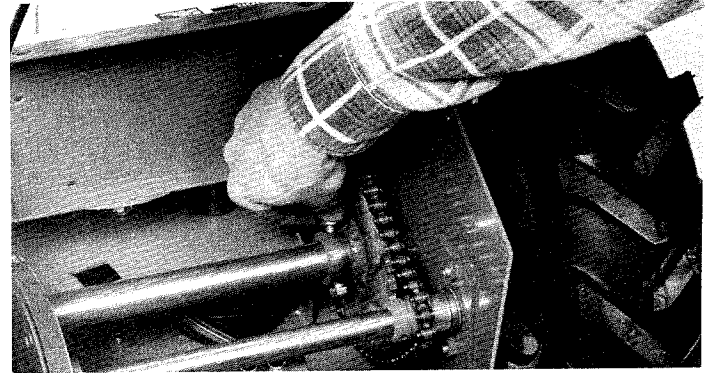

Photo 5-11: Removing the wheel shaft sprocket bolt.

6. Remove the clinch pin and the clevis pin from the right-hand wheel. Then slide the wheel off the wheel shaft.

CAUTION

When prying the klip-ring off the wheel shaft, wear safety glasses to protect your eyes.

Failure to do this could result in personal injury.

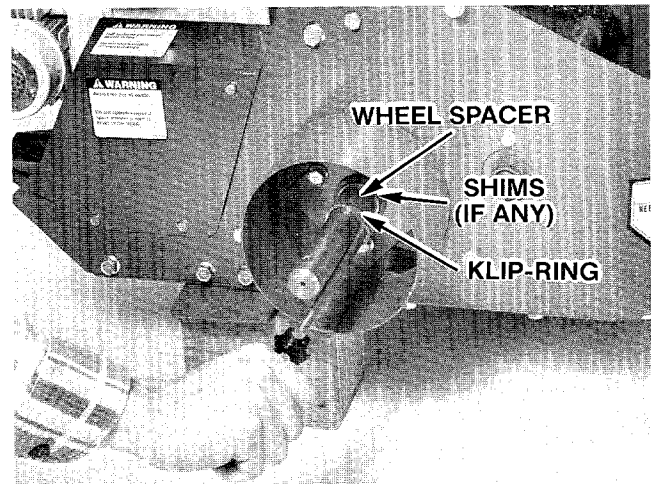

Photo 5-12: Removing the klip-ring from the wheel shaft.

7. Use the screwdriver to carefully pry the klip-ring off the wheel shaft. Use care not to lose the klip-ring if it should fly off the shaft.

- Slide the wheel spacer and shims (if any) off the wheel shaft. Be sure not to lose the shims.

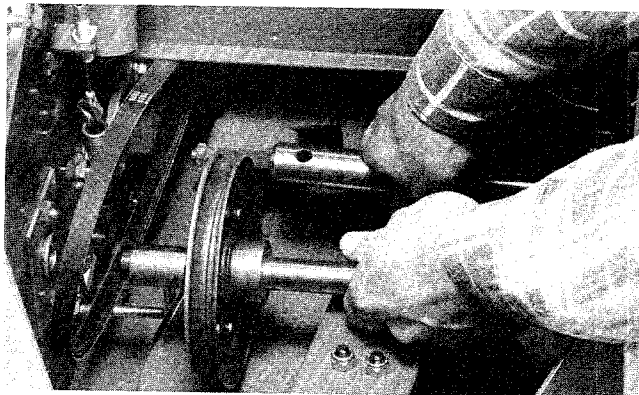

Photo 5-13: Moving the wheel shaft and jackshaft.

- Move the wheel drive belt off the jackshaft pulley. Make sure that it is moved to the right hand side of the pulley.
- Slide the jackshaft and the wheel shaft to the left until the right-hand ends of both shafts are free. A bushing and spacer(s) will fall off the right-hand side of the jackshaft. Save them, since you'll need to reinstall them later.

HINT: Use a soft-faced hammer on the right-hand end of the wheel shaft if it is tough to remove. Use the hammer and the large straight punch to tap the jackshaft to the left if you cannot easily move it by hand.

- Use the 5/16-inch wrench to remove the bolts that secure the wheel drive belt cover to the mower.

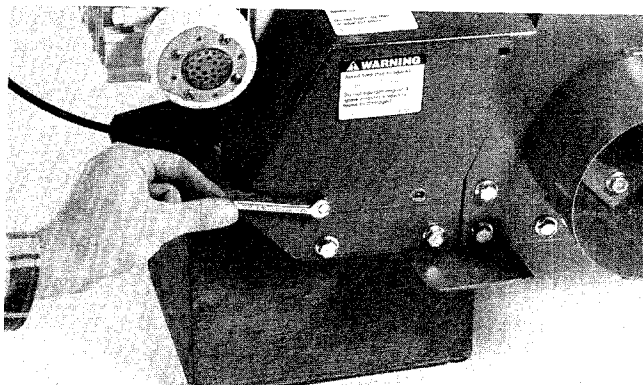

Photo 5-14: Removing the wheel drive belt cover.

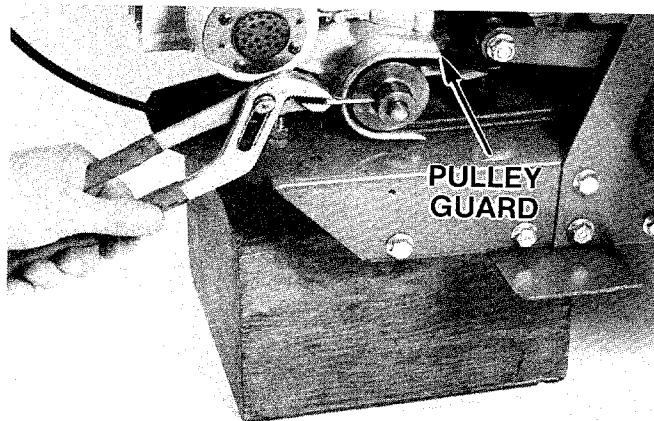

Photo 5-15: Removing the PTO pulley's cotter pin.

- Use the pliers to remove the cotter pin that secures the engine Power Take Off (PTO) pulley to the engine's PTO shaft.
- Slide the PTO belt guide, the wheel drive belt, and the PTO pulley off the engine's PTO shaft. Take the belt off the pulley.
- Move the wheel drive belt around the right-hand end of the jackshaft and the wheel shaft. Push the wheel drive belt to the rear and remove it from the mower.

To install the wheel drive belt:

NOTE

If you're installing a new belt, close up the adjuster in the middle of the wheel drive control cable. Also screw in the adjuster on the lower end of the control cable. Refer to Steps 1 through 4 of "Wheel Drive Initial Setting".

- Check the engine PTO shaft to make sure that there is a felt washer installed on the PTO shaft. Replace the felt washer if necessary (See the Parts Catalog for replacement information.)
- Push the front end of the wheel drive belt beneath the wheel drive idler pulley and then forward into the mower's chassis. Loop the wheel drive belt around the PTO pulley and then slide the PTO pulley onto the engine's PTO shaft.
- Rotate the PTO pulley on the engine PTO shaft until the PTO pulley cotter pin holes align with the cotter pin hole through the engine PTO shaft. We recommend that you install a new cotter pin through the holes. Use the pliers to bend the legs of the cotter pin around the PTO pulley hub so that the cotter pin can't come out. See Photo 5-16.



MAINTENANCE

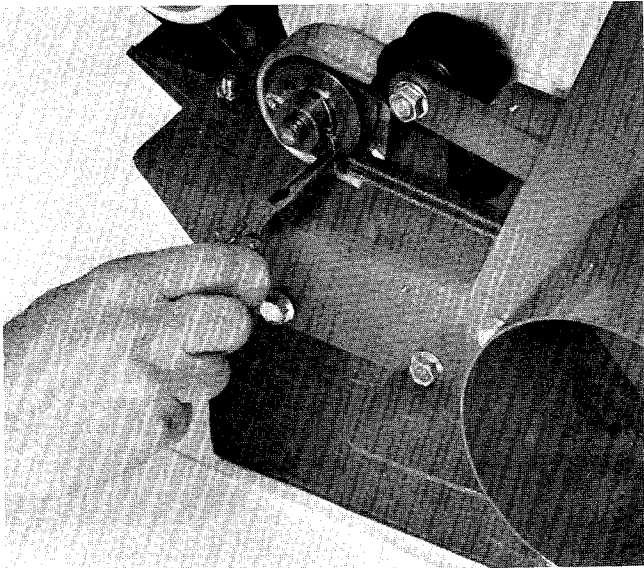

Photo 5-16: Installing the Cotter Pin.

4. Inside the mower's chassis, loop the forward end of the wheel drive belt around the large pulley on the right-hand side of the jackshaft. Make sure that the wheel drive belt is above the belt guide pin. See photo 5-17.
5. Then slide the wheel shaft to the right, through the loop of the belt, into its respective hole in the right-hand frame plate. Make sure that you push the wheel shaft to the right, as far as it will go.
6. Reinstall the spacer and shim(s) (if any) on the right-hand end of the jackshaft. Slide the jackshaft to the right into its bushing in the right-hand frame plate.

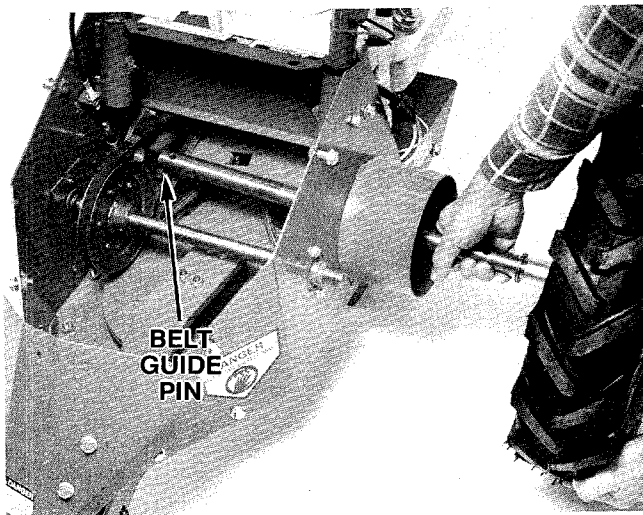

Photo 5-17: Reinserting the wheel shaft and jackshaft into the right-hand frame plate.

7. Place the shims (if any) and the wheel spacer onto the right-hand end of the wheel shaft. Slide them inward all the way.

8. Use the pair of pliers to snap the klip-ring into the groove in the right-hand side of the wheel shaft.

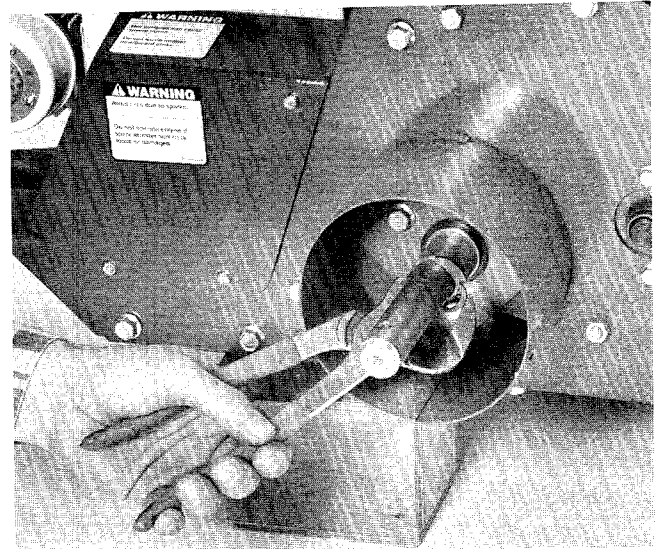

Photo 5-18: Reinstalling the klip-ring on the axle shaft.

9. Reinstall the wheel on the right-hand side of the wheel shaft.
10. Remove the wooden blocks from beneath the mower's chassis.
11. Align the holes in the hub of the large sprocket with the hole through the left-hand side of the wheel shaft. Insert the bolt through these holes and place the nut on the end of the bolt. Use the two 1/2-inch wrenches to very securely tighten the nut.

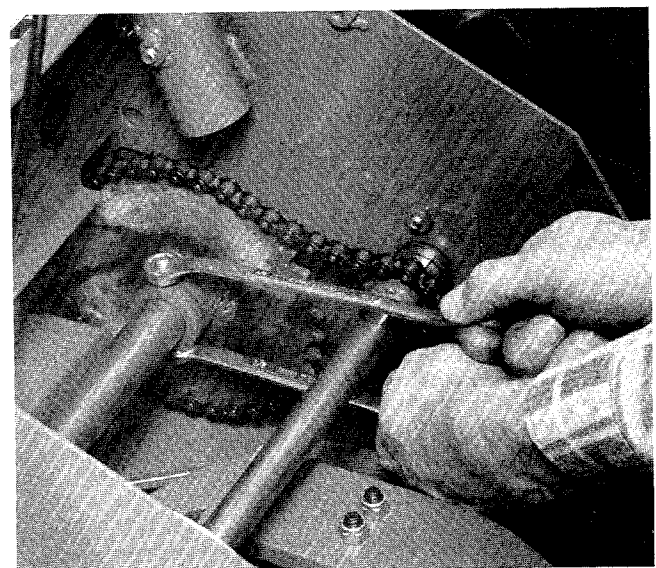

Photo 5-19: Reinstalling the sprocket on the jackshaft.

12. Align the holes in the hub of the small sprocket with the hole through the left-hand side of the jackshaft. Insert the spirol pin into these holes and use the ¼-inch straight punch and hammer to drive the spirol pin back into these holes.

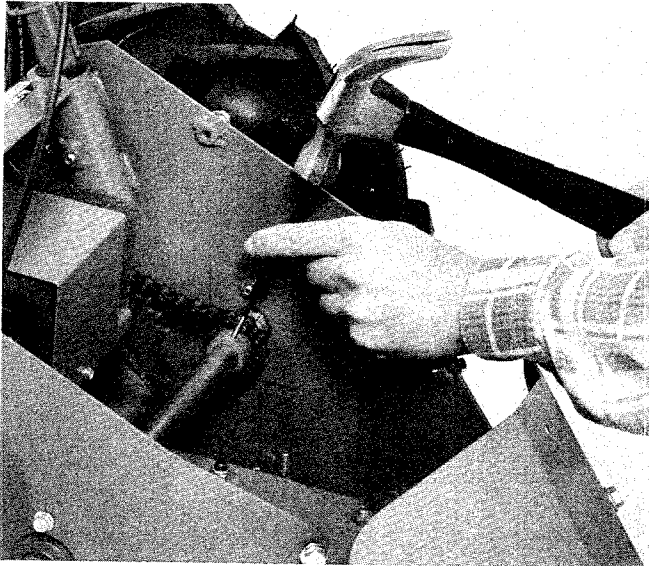

Photo 5-20: Driving the spirol pin back into the jackshaft sprocket/jackshaft.

13. Adjust the wheel drive system. See "Wheel Drive Adjustment (General)".

14. Reinstall the wheel drive belt cover to the right-hand side of the mower. Use the 5/16-inch wrench to securely tighten the bolts that secure the pulley cover in place.

15. Reinstall the hood to the side plates and rear hood. Securely tighten the six bolts that secure it in place.

16. After several hours of operation you may have to adjust the wheel drive system again (due to the belt's having become seated on the pulleys). Refer to "Wheel Drive Adjustment (General)".

Wheel Drive Adjustment (General)

If you have replaced any of the wheel drive system components (belt, control cable, control lever, idler arm spring, etc.) you will need to perform the Initial Setting (described on Page 28) prior to performing the Wheel Drive Check (described below).

If you have not replaced any of the wheel drive system components and the wheel drive system is not operating properly, perform the Wheel Drive Check prior to making the Main Adjustment (described on Page 28).

Wheel Drive Check

⚠ WARNING

You are about to perform an operational check. Be sure that:

- You perform this check outdoors.
- The plastic blade protector is installed on the blade.
- No children or other bystanders are nearby.
- You perform this check in an open area, such as a driveway.
- The mower is pointed in a safe direction.

Failure to follow these instructions could result in personal injury or property damage.

1. Move the mower to a hard-surfaced, clean, level area (such as a driveway). Point the mower in a safe direction.
2. Start the mower's engine and allow it to warm up.
3. Quickly squeeze and release the Wheel Drive Lever. The wheels should begin to turn when you squeeze the lever. They should stop when you release the lever. If they don't stop, the tension on the wheel drive cable is too high.

⚠ WARNING

If the wheels do not stop turning when the Wheel Drive Lever is released, shut the engine off, disconnect the spark plug wire, and do not operate the mower until this problem has been repaired.

Failure to do so could result in personal injury or property damage.

4. Re-engage the Wheel Drive Lever while you prevent the mower from moving forward by firmly holding the handlebars. The wheels should spin on the driveway. If they do not spin, the tension on the wheel drive cable is too low.

5. If the mower fails this Check, proceed to the Main Adjustment on the next page.

MAINTENANCE

Wheel Drive Initial Setting

1. Using two $\frac{3}{8}$ -inch open-end wrenches, loosen the jam nut on the wheel drive cable upper adjuster. Turn the jam nut all the way up the threaded barrel on the main adjuster. Then turn the barrel up the threaded barrel until it is approximately $\frac{1}{8}$ -inch away from the jam nut as shown in Photo 5-21. This decreases tension on the wheel drive cable.

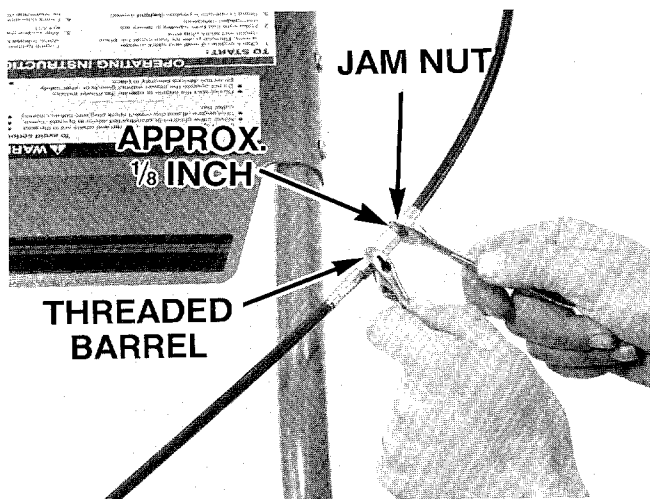
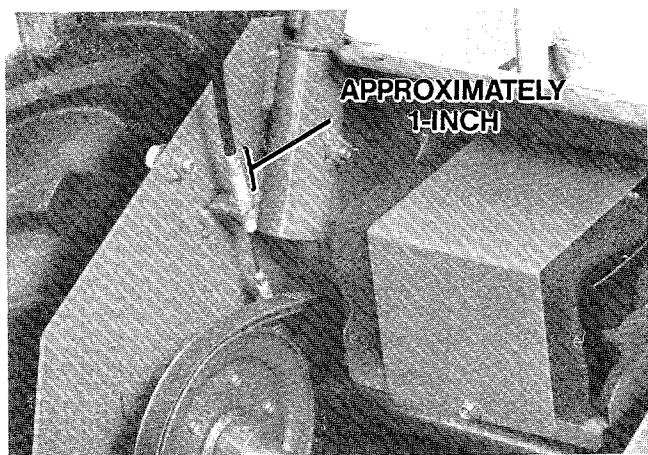

Photo 5-21: Setting the upper adjuster.

2. Remove the two bolts that attach the hood to the rear hood. Loosen the four bolts that secure the sides of the hood to the side frames. Take the hood off the mower.

3. Use a $\frac{1}{2}$ -inch wrench to loosen the lower jam nut on the lower wheel drive cable adjuster. (The lower jam nut is located beneath the cable holder that is welded to the inside of the right-hand side frame.)

4. Turn the upper jam nut on the adjuster until you get a dimension of approximately 1-inch between the top of the upper jam nut and the top of the adjuster as shown in Photo 5-22.



28 Photo 5-22: Setting the lower adjuster.

5. Push the mower forward and backward approximately 4 to 5 feet to make sure that the wheels turn freely. (Don't engage the Wheel Drive Lever.)

6. Gradually open the upper adjuster by turning its barrel clockwise (as viewed from above) one complete turn. Then perform Step 5. If the wheels turn freely, turn the barrel another complete turn and again repeat Step 5. Keep doing this until you lose free wheel (the wheels won't turn freely). After you lose free wheel, turn the adjuster barrel counterclockwise until your mower freewheels when you repeat Step 5.

7. When you obtain freewheel, tighten the lower jam nut on the lower adjuster. Then tighten the jam nut on the upper adjuster against the adjuster barrel.

8. Perform the Wheel Drive Check (on Page 27) to make sure that your adjustment is correct.

9. Reinstall the hood.

Wheel Drive Main Adjustment

1. Perform the Wheel Drive Check.

2. Use two $\frac{3}{8}$ -inch open-end wrenches to loosen the jam nut on the wheel drive cable's upper adjuster.

3. If, during the Wheel Drive Check, you found that you could keep the wheels from spinning on the driveway, there is not enough tension on the cable. Increase its tension as follows:

- Open the upper adjuster by turning the adjuster barrel clockwise (as viewed from above) approximately one-half of a turn.
- Perform the Wheel Drive Check to see if this adjustment is correct.
- Repeat Steps 3a and 3b until the mower passes the Wheel Drive Check.

NOTE

If you've unscrewed the upper adjuster as far as you can and you can still prevent the mower's wheels from turning during the Wheel Drive Check, repeat the Wheel Drive Initial Setting. However, this time increase the dimension shown in Photo 5-22 as necessary to take up the excess slack in the system.

4. If, during the Wheel Drive Check, you found that the wheels rotated before you engaged the Wheel Drive Lever, or that they continued to rotate after you released the Wheel Drive Lever, there is too much tension on the cable. Reduce the tension as follows:

- Close the upper adjuster by turning the adjuster barrel counterclockwise (as viewed from above) approximately one-half a turn.
- Perform the Wheel Drive Check to see if this adjustment is correct.
- Repeat Steps 3a and 3b until the mower passes the Wheel Drive Check.

Cutter Bar Drive Belt Removal and Installation

CAUTION

Before removing or installing the cutter bar drive belt, shut the engine off, allow it to cool, disconnect the spark plug wire and prevent it from touching the spark plug, and reinstall the plastic blade protector on the front of the blade. For electric start models, also remove the Engine Ignition key from the keyswitch.

Failure to do this could result in personal injury or property damage.

You'll need the following items to change the cutter bar drive belt. You should have all these items close at hand before beginning belt removal.

1. A replacement **original** equipment cutter bar drive belt (if the old belt is bad).
2. A 100 foot-pound torque wrench.
3. A 15/16-inch socket and a 1/2-inch or 3/4-inch drive breaker bar.
4. A 1-inch box end wrench.
5. A 1/2-inch wrench.
6. Clean automotive-type grease.

To remove the cutter bar drive belt:

1. Use the 1/2-inch wrench to remove the three bolts that attach the weed deflector support to the drive arm. (The heads of these three bolts are located beneath the drive arm.)

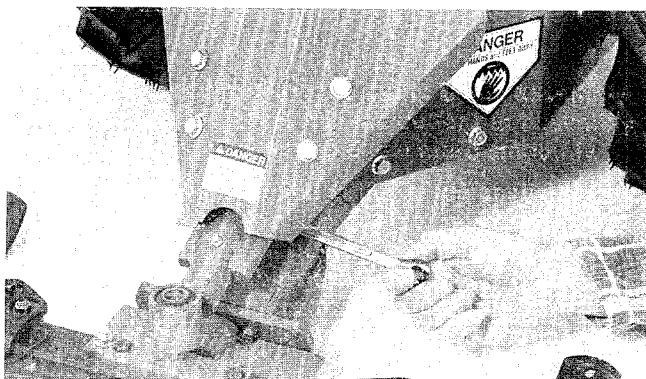

Photo 5-23: Removing the weed deflector.

2. Use the 1/2-inch wrench to remove the two bolts that attach the rear of the hood to the rear hood. Then loosen the four (two on each side) bolts that secure the hood to the right and left frame plates. Remove the hood from the mower.



Photo 5-24: Removing the hood.

3. Remove the nut from the drive arm pivot bolt by placing the 1-inch box end wrench on the head of the bolt (beneath the mower) and loosening the nut with the breaker bar and 15/16-inch socket.

NOTES

- This nut is installed very tightly at the factory (100 foot-pounds of torque).
- If the nut is difficult to remove, apply penetrating oil to the nut and bolt threads. Allow it to work in for a few minutes. Then try to remove the nut.
- It is easier to have an assistant helping you when removing the nut. The assistant holds the 1-inch box end wrench in place while you loosen the nut. If you don't have an assistant, brace the left end of the cutter bar against a solid object to prevent the mower from turning when you loosen the nut.

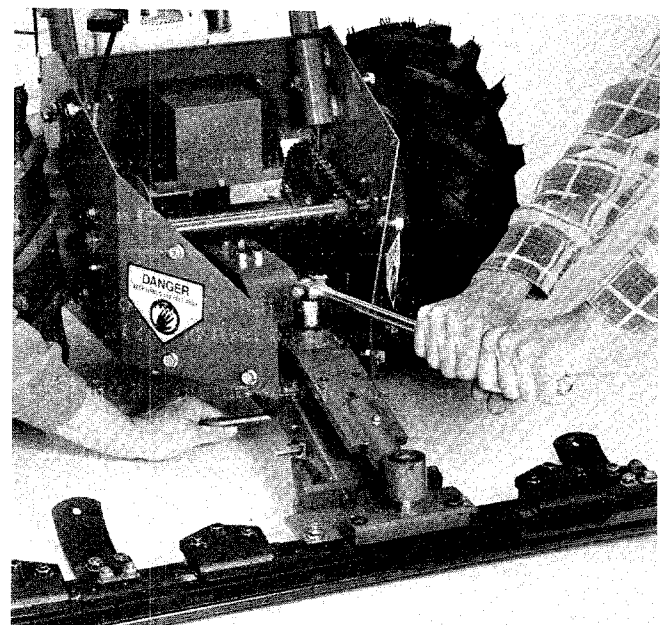

Photo 5-25: Loosening the drive arm pivot bolt nut.

MAINTENANCE

4. Lift the washer off the upper end of the pivot bolt.
5. Lift the drive arm off the mower. When you lift the drive socket off the drive pin (on the cutter bar), the drive socket is free to slip out of the end of the drive arm.



Photo 5-26: Removing the drive arm.

6. Use the ½-inch wrench to remove the nine bolts that secure the cutter bar belt cover to the rear of the mower.

HINT: Placing wooden blocks beneath both wheels will raise the rear of the mower so that you will have more room when you are removing the lower bolts.

7. Remove the two bolts that attach the wire-form belt guide to the bottom of the engine deck plate. Take the belt guide off the mower.

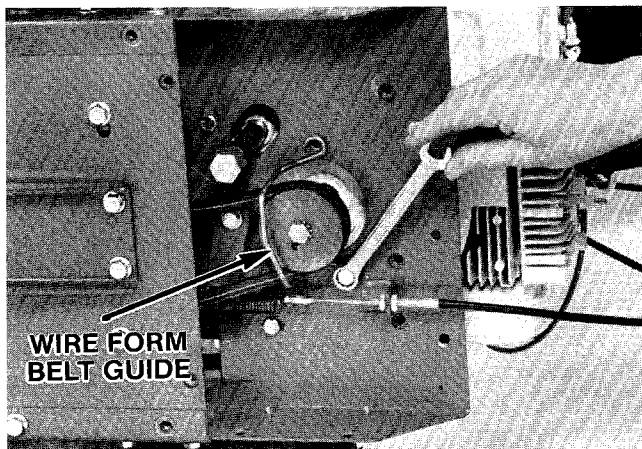

Photo 5-27: Removing the wire-form belt guide.

8. To get more slack in the wheel drive system, close up both adjusters on the cutter bar drive cable.

9. Remove the forward belt guide pin as shown in Photo 5-28.

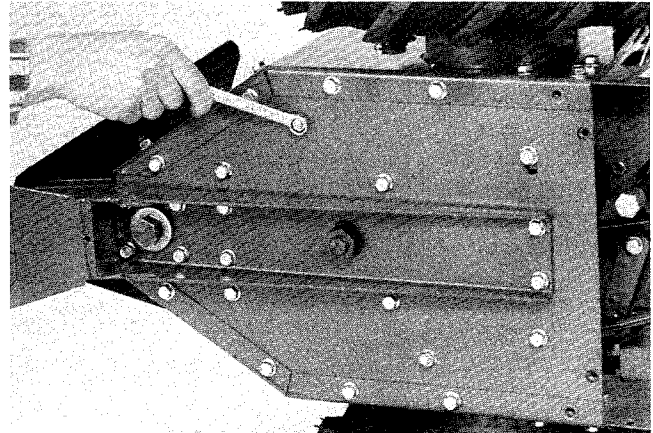

Photo 5-28: Removing the forward belt guide pin.

10. Lift the cutter bar drive belt off the flywheel and then off the engine pulley. Remove the belt from the mower.

To install the cutter bar drive belt:

1. Take the cutter bar drive belt and place it in the grooves in the flywheel and engine pulley. Make sure that the belt goes to the inside (right-hand side) of the idler pulley. Also make sure that the belt goes to the inside of the rear belt guide pin.

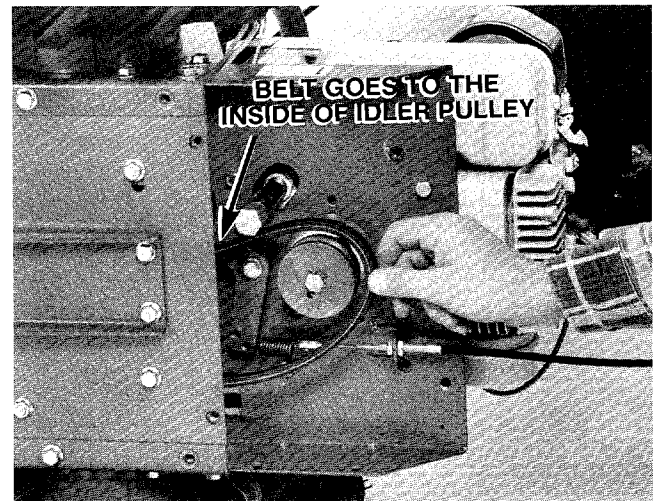

Photo 5-29: Placing the cutter bar drive belt on the engine pulley.

- Place the wire-form belt guide over the cutter bar belt as shown in Photo 5-30. Secure the wire-form belt guide in place with the previously removed bolts.

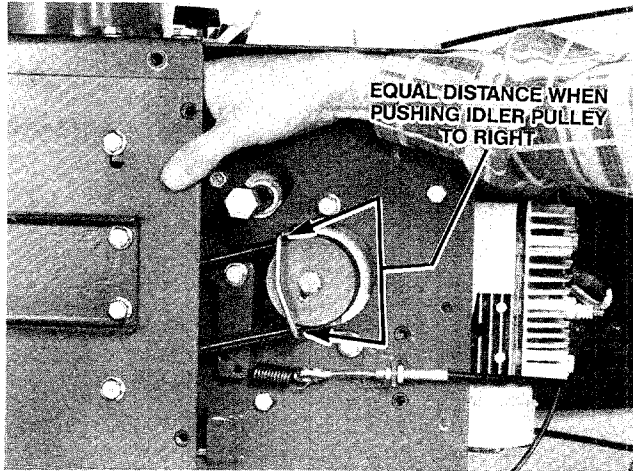

Photo 5-30: Reinstalling the wire-form belt guide.

- Push the idler pulley to the right so that it applies tension to the cutter bar drive belt. Check the wire-form belt guide to make sure that there is an equal gap on both sides of the belt between the "legs" of the wire-form belt guide and the outer surfaces of the cutter bar drive belt. See Photo 5-30. If the gaps are not equal, check the wire-form belt guide for damage. Replace it with a new one if necessary.

- Reinstall the forward belt guide pin.

- Remove the wooden blocks from beneath the mower's wheels.

- Clean any dirt or old grease off the flywheel and the back channel of the drive arm. Apply fresh automotive-type grease to the inside surfaces of the back channel.

- Make sure that the drive socket is in place in the forward end of the drive arm. Place the drive arm onto the drive arm pivot bolt, making sure that:
 - The drive socket on the front of the drive arm goes onto the cutter bar drive pin.
 - The back channel on the drive arm goes over the eccentric bearing on the top of the flywheel. If necessary, rotate the flywheel by hand to line up the eccentric bearing with the back channel.

- Place the washer onto the drive arm pivot bolt. Then screw the nut onto the drive arm pivot bolt until it's finger tight.

- Place the 1-inch box end wrench on the head of the drive arm pivot bolt. Put the 15/16-inch socket on a 100 foot-pound torque wrench and tighten the nut on the drive arm pivot bolt to 100 foot-pounds.

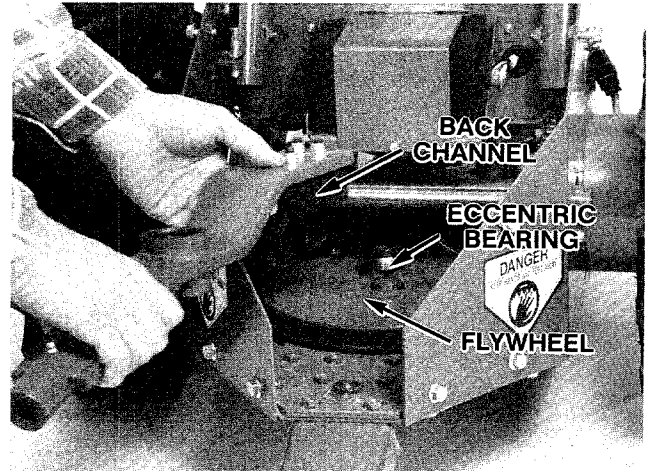

Photo 5-31: Reinstalling the drive arm.

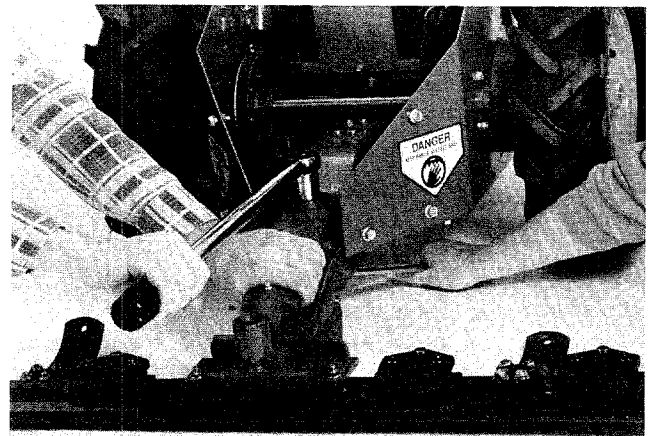

Photo 5-31A: Torqueing the nut on the drive arm pivot bolt.

NOTE

It is easier if you have an assistant to help when you torque this nut. If you don't have an assistant, brace the right-hand end of the cutter bar against a solid object to prevent the mower from moving when you tighten the nut.

- Adjust the cutter bar drive system. Refer to "Cutter Bar Drive Adjustment (General)".

- Install the cutter bar belt cover in place beneath the engine deck. Use the 1/2-inch wrench to evenly tighten all nine bolts that secure it in place. Note that the single, 1/2-inch long bolt goes into the middle hole at the rear of the cover.

- Reinstall the hood to the side frame plates and rear hood. Use the 1/2-inch wrench to evenly tighten the six bolts that secure the hood in place.

- After several hours of operation, you may have to repeat the cutter bar drive adjustment procedure due to the new belt's having become seated in the grooves in the engine driven pulley and flywheel.

MAINTENANCE

Cutter Bar Drive Adjustment (General)

If you have replaced any of the cutter bar drive system components (belt, control cable, control lever, idler arm spring, etc.) you will need to perform the Initial Setting prior to performing the Cutter Bar Drive Check.

If you have not replaced any of the cutter bar drive system components and the cutter bar drive system is not operating properly, perform the Cutter Bar Drive Check prior to making the Main Adjustment.

Cutter Bar Drive Check

⚠ WARNING

You are about to perform an operational check. Be sure that:

- You remove the plastic blade protector before starting the engine.
- No children or other bystanders are nearby.
- You start the engine and perform this check outdoors.
- The mower is pointed in a safe direction.

Failure to follow these instructions could result in personal injury or property damage.

1. Start the engine and allow it to warm up.
2. Quickly squeeze and release the Blade Drive Lever. The cutter bar should begin to oscillate when you squeeze the lever. It should stop oscillation when you release the lever.

⚠ DANGER

If the cutter bar does not stop oscillating when you release the Blade Drive Lever, or if it oscillates before you squeeze this lever, shut the mower's engine off, wait until it cools, disconnect the spark plug wire and prevent it from touching the spark plug. Do not use the mower until the cutter bar drive mechanism is repaired so that the cutter bar stops oscillating when the Blade Drive Lever is released. See "Cutter Bar Drive Adjustment (General)" in Section 5 of this Manual.

Failure to follow this instruction could result in personal injury or property damage.

3. If the cutter blade doesn't oscillate, the cable tension is too low. If the cutter blade oscillates before you squeeze the Blade Drive Lever, or if it continues to oscillate after you release this lever, the cable tension is too high.
4. If the mower fails this check, proceed to the Cutter Bar Drive Main Adjustment.

Cutter Bar Drive Initial Setting

NOTE

You must perform this procedure after replacing any of the cutter bar drive components (belt, control lever, cable, idler arm spring, etc.).

1. Use two $\frac{3}{8}$ -inch open-end wrenches to loosen the jam nut on the adjuster that is in the middle of the cutter bar drive control cable. Turn the jam nut all the way up the threaded barrel on the adjuster. Then turn the barrel up the threaded barrel until it is approximately $\frac{1}{8}$ -inch from the jam nut as shown in Photo 5-32. This decreases tension on the cutter bar drive cable.

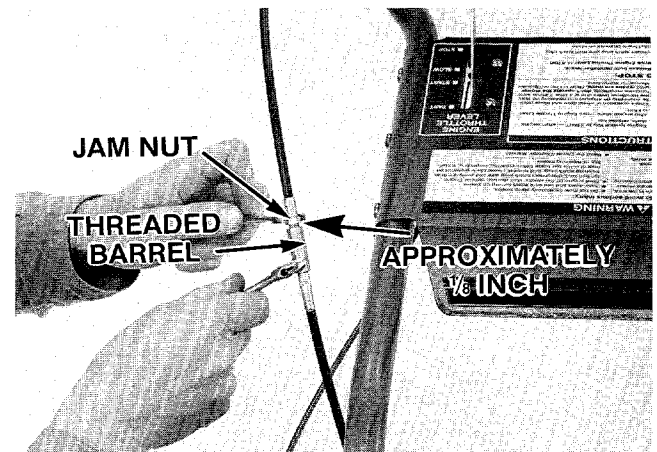

Photo 5-32: Setting the upper adjuster.

2. Use a $\frac{1}{2}$ -inch wrench to remove the eleven bolts that secure the cutter bar belt cover and cable protector beneath the engine deck. Take the cutter bar belt cover off the mower.
3. Use a $\frac{1}{2}$ -inch open-end wrench to loosen the forward jam nut on the lower cutter bar drive cable adjuster. (This forward jam nut is located in front of the cable holder that is welded to the bottom of the right-hand side of the engine deck.)

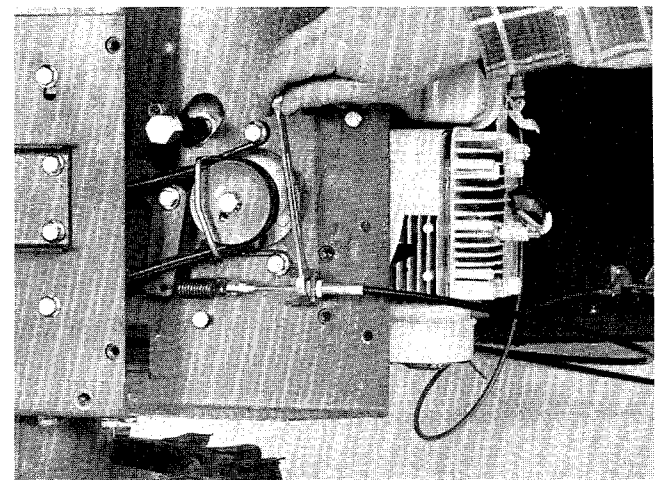

Photo 5-33: Loosening the forward jam nut.

- Turn the rear jam nut on the adjuster until you get a dimension of approximately 1 1/4-inch between the rear of the jam nut and the top of the adjuster as shown in Photo 5-34.

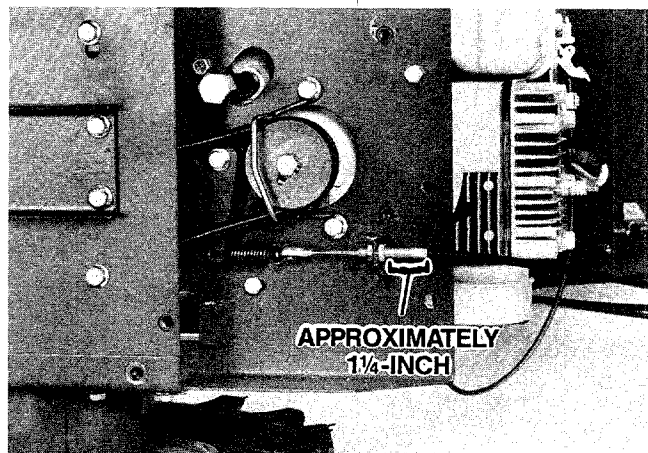

Photo 5-34: Setting the Lower Adjuster.

- Use a 1/2-inch open-end wrench to hold the rear jam nut in place while you tighten the forward jam nut with another 1/2-inch open-end wrench. Don't over-tighten the jam nut or you could break the threaded end of the control cable.

- Perform the Cutter Bar Drive Check. If the mower passes this check, you are finished. If the mower doesn't pass, go on to perform the Cutter Bar Drive Main Adjustment.

- Reinstall the cutter bar belt cover and cable protector beneath the engine deck.

Cutter Bar Drive Main Adjustment

⚠ WARNING

You are about to perform an operational check. Be sure that:

- You remove the plastic blade protector before starting the engine.
- No children or other bystanders are nearby.
- You start the engine and perform this check outdoors.
- The mower is pointed in a safe direction.

Failure to follow these instructions could result in personal injury or property damage.

- Perform the Cutter Bar Drive Check.
- Use two 3/8-inch open-end wrenches to loosen the jam nut on the cutter bar drive cable's upper adjuster.

- If, during the Cutter Bar Drive Check, you found that the cutter blade did not oscillate when you engaged the Blade Drive Lever, there is not enough tension on the cable. Increase it as follows:
 - Start the mower's engine and allow it to warm up.
 - Open the upper adjuster by turning the barrel clockwise (as viewed from above) until the cutter bar blade just begins to oscillate.

NOTE

If you've unscrewed the upper adjuster as far as you can and the cutter bar still does not oscillate when you engage the Blade Drive Lever, shut the engine off and repeat the Cutter Bar Drive Initial Setting. However this time increase the dimension shown in Photo 5-34 as necessary to take up the excess slack in the system.

- Then turn the adjuster barrel counterclockwise (as viewed from above) until the cutter bar blade stops oscillating.
 - Shut the engine off.
 - Hold the barrel in place while you tighten the jam nut.
 - Perform the Cutter Bar Drive Check to make sure that the adjustment is correct.
- If, during the Cutter Bar Drive Check, you found that the cutter bar oscillated before you engaged the Blade Bar Drive Lever or that the cutter bar continued to oscillate after you released the Blade Drive Lever, there is too much tension on the cutter bar drive cable. Reduce tension as follows:
 - Start the mower's engine and allow it to warm up.
 - Close the upper adjuster by turning the barrel counterclockwise (as viewed from above) until the cutter bar just stops oscillating.
 - Shut the engine off.
 - Hold the adjuster barrel in place and tighten the jam nut.
 - Perform the Cutter Bar Drive Check to make sure that the adjustment is correct.



MAINTENANCE

Cutter Bar Maintenance

Removal and Installation of the Cutter Bar Assembly

CAUTION

Before removing or installing the cutter bar assembly, shut the engine off, allow it to cool, disconnect the spark plug wire and prevent it from touching the spark plug, and reinstall the plastic blade protector on the front of the blade. For electric start models, also remove the Engine Ignition key from the keyswitch.

Failure to do this could result in personal injury or property damage.

To remove the cutter bar assembly:

1. Remove the crank pin from the right-hand side of the frame by pushing downward on the crank pin's "handle" until it snaps free of its retaining clip. Then pull the crank pin to the right, out of the hole.

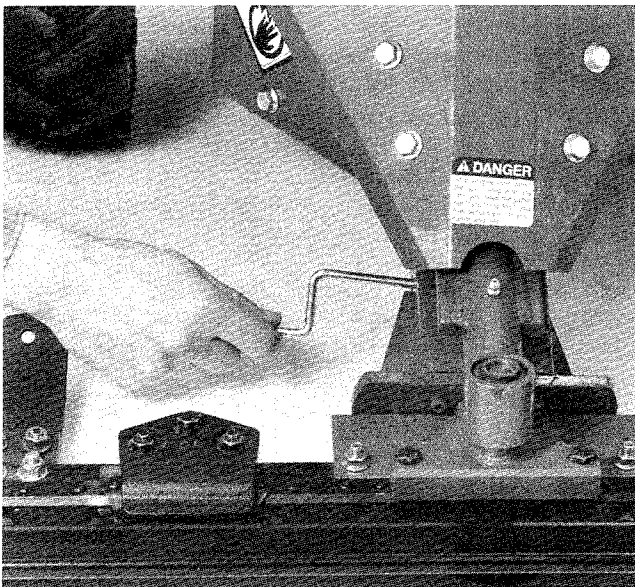

Photo 5-35: Removing the cutter bar crank pin.

2. Have an assistant hold the handlebars while you're removing the cutter bar assembly (in Step 3). Without the cutter bar assembly installed, the mower could tip rearwards.

3. Use both hands (one on each side of the cutter bar) to pull the cutter bar assembly forward, off the mower. You may find it helpful to wiggle the ends of the cutter bar assembly up and down as you're pulling it forward.

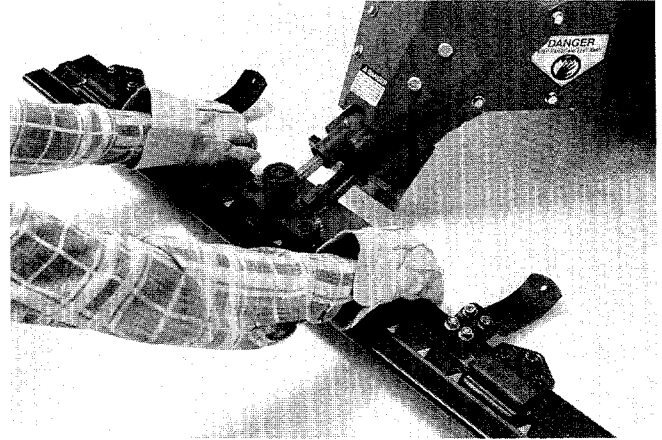

Photo 5-36: Removing the cutter bar assembly.

4. Have your assistant slowly lower the mower's handlebars until the mower rests on the bottom of its engine deck. The mower's nose will be tilted upward.
5. So that you don't misplace it, reinstall the crank pin in the side of the mower frame and make sure that it's snapped into its retaining clip.

To reinstall the cutter bar assembly:

1. Remove the crank pin from the right-hand side of the mower.
2. Have an assistant grasp the handlebars to steady the mower while you're reinstalling the cutter bar assembly.
3. Move the drive arm from side to side until it is above, and parallel with the cutter bar mount.

HINT: If you find the drive arm difficult to turn: 1) make sure that the spark plug wire is disconnected from the spark plug, 2) squeeze the cutter bar drive lever, and 3) very slowly pull the engine recoil starter rope.

As you pull the recoil starter rope, the drive arm will move from side to side. When it lines up with the cutter bar mount, stop pulling the recoil starter rope.

4. Clean any dirt, rust, or old grease off the mounting shaft and the shaft on the cutter bar drive socket. Apply fresh grease to them.
5. Place the drive socket onto the cutter bar drive pin.

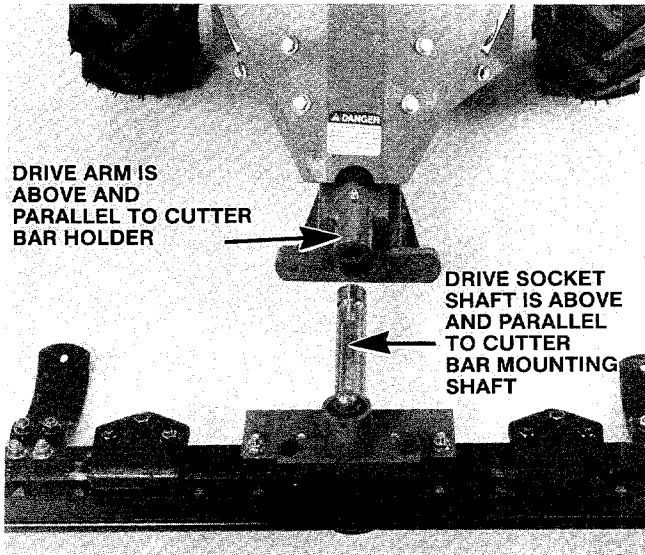

Photo 5-37: Positions for installing cutter bar.

6. Slide the cutter bar sideways until the shaft on the drive socket is above and parallel to the cutter bar mounting shaft.

7. Lift the cutter bar assembly off the floor. Insert the shaft on the end of the cutter bar mount into the hole in the forward end of the cutter bar holder. Slowly begin pushing the cutter bar assembly rearward. Align the shaft on the drive socket with the hole in the forward end of the drive arm and continue slowly pushing the cutter bar assembly rearward. You may find it helpful to wiggle the ends of the cutter bar assembly up and down while you're pushing the shafts on the cutter bar assembly into their holes.

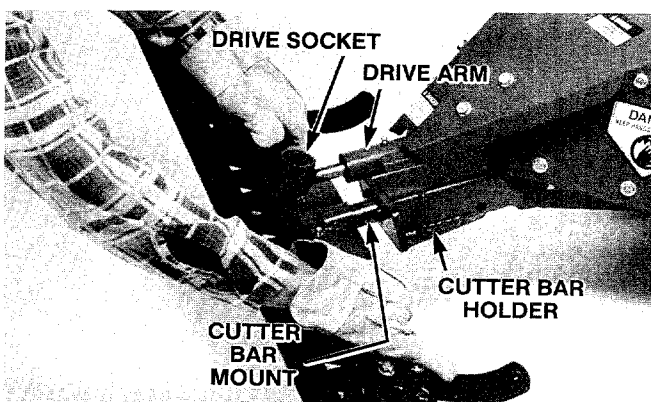

Photo 5-38: Installing the cutter bar.

8. Make sure that you push the cutter bar all the way to the rear. Then insert the longer "leg" of the crank pin into the hole in the right-hand side of the frame. Push the crank pin all the way through until its end comes out of the hole in the left-hand side frame. Rotate the "handle" of the crank pin counterclockwise until it snaps under the clip.

9. Try to pull the cutter bar assembly forward, off the mower. If you can pull it off the mower, it wasn't pushed in far enough when you installed the crank pin. You'll have to remove the crank pin, push the cutter bar assembly all the way in, and then reinstall the crank pin.

Blade Guide Maintenance

CAUTION

Before performing any maintenance on or near the blade guides, shut the mower's engine off, disconnect the spark plug wire and prevent it from touching the spark plug, and reinstall the plastic blade protector on the front of the cutter bar blade.

Failure to do so could result in personal injury or property damage.

Through normal usage, the blade guides will tend to loosen or wear. You may notice that the blade guides are loose when the cutter bar has a difficult time cutting thinner vegetation such as lawn grass. Also, when the cutter bar is oscillating, you may notice that it makes more noise than usual.

Every 10 hours of mower operation you should check the blade guides for adjustment. If they are out of adjustment, perform the Blade Guide Adjustment procedure.

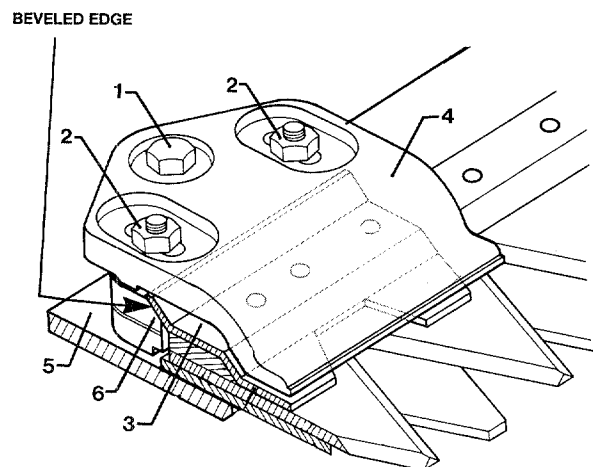

Figure 5-39: Side view of the adjustable cutter bar blade guide.



MAINTENANCE

Blade Guide Adjustment

The object of adjusting the cutter bar assembly's four blade guides is to make the cutter blade assembly as snug as possible in the blade guides without having it bind when it moves from side to side.

CAUTION

- Before adjusting the blade guides, shut the engine off, disconnect the spark plug wire and prevent it from touching the spark plug. Also, on electric start models, remove the Engine Ignition key.
 - When working on or near the cutter bar, wear heavy leather gloves to protect hands and fingers.
- Failure to do this could result in personal injury or property damage.

1. Remove the cutter bar assembly from the mower. Refer to Page 34 for instructions.
2. Lift the drive socket off the cutter blade drive pin.
3. Move the cutter blade assembly sideways until its four wear plates are centered beneath the four blade guide assemblies. See Photo 5-40.
4. Loosen the rear adjustment bolt on each of the four blade guide assemblies. Then loosen the two clamp nuts on each of the four blade guide assemblies.

NOTE

For best results, remove the two clamp nuts, lift the blade guide and blade guide support up, off the bolts, and brush or scrape off any dried grass or other debris. When you reinstall the blade guide support, make certain that the beveled edge on its front is facing up.

5. Thoroughly oil the blade.
6. Begin the adjustment with the inner right-hand blade guide assembly. Push forward on the blade guide support and rearward on the blade guide while you evenly and securely tighten the two clamp nuts.
7. Slide the cutter blade back and forth to make sure that the cutter blade assembly doesn't bind. If it binds, tap the blade guide forward slightly until you can just slide the cutter blade assembly from side to side.

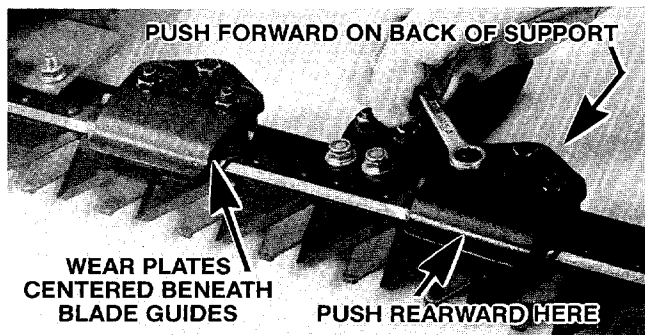

36 Photo 5-40: Tightening the clamp nuts.

8. Repeat Steps 6 and 7 on the left-hand inner, the right-hand outer, and finally on the left-hand outer blade guide assembly.

9. Move the cutter blade assembly from side to side until its four wear plates are again centered beneath the four blade guide assemblies.

10. Slowly tighten the rear adjustment bolt on the right-hand inner blade guide until you can no longer move the cutter blade assembly from side to side. Then slowly loosen the rear adjustment bolt until you can just move the cutter blade assembly from side to side.

11. Repeat Steps 9 and 10 for the left-hand inner, the right-hand outer, and the left-hand outer blade guide assemblies.

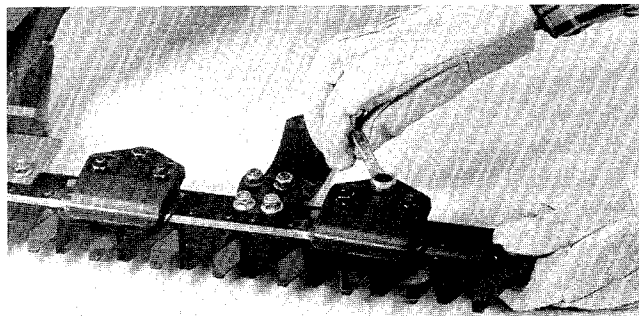

Photo 5-41: Adjusting the rear adjustment bolt.

12. Place the drive socket on the drive pin and reinstall the cutter bar assembly on the mower. See Page 34 for instructions.

Removing and Installing the Cutter Blade Assembly

CAUTION

- Before removing or installing the cutter blade assembly, shut the engine off, disconnect the spark plug wire and prevent it from touching the spark plug. On electric start models, also remove the Engine Ignition key from the key-switch.
- When removing or installing the cutter bar blade assembly, wear heavy leather gloves to help prevent the blades from accidentally pinching or cutting your fingers or hands.

Failure to do so could result in personal injury.

To remove the cutter blade assembly from the cutter bar assembly:

1. Use a 13 MM (or a 1/2-inch) wrench to remove the two bolts that secure the cutter bar drive pin to the top of the cutter blade assembly.

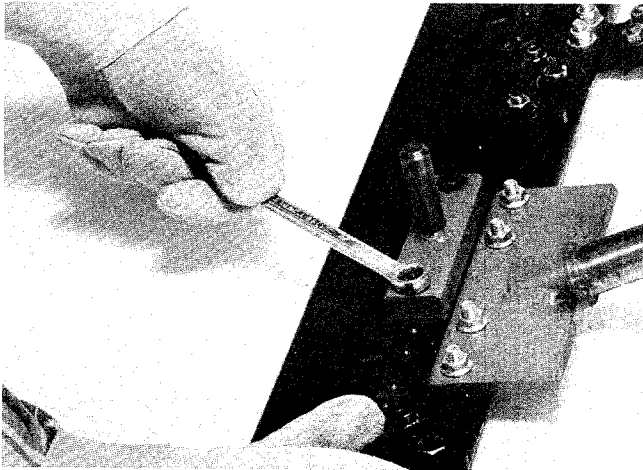

Photo 5-42: Removing the drive pin retaining bolts.

2. Slide the cutter blade assembly sideways through the blade guides and out of the cutter bar.

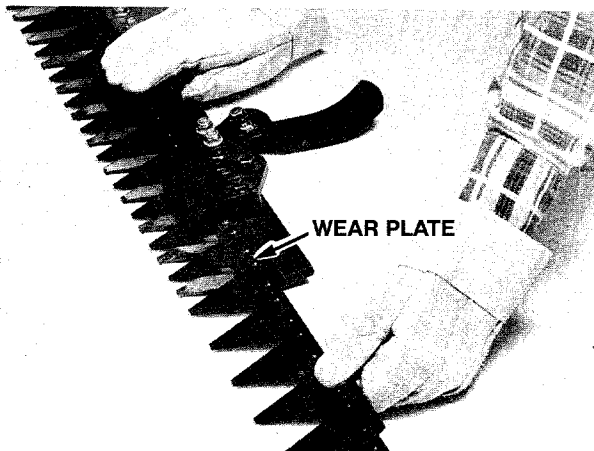

Photo 5-43: Removing the cutter bar.

To install the cutter blade assembly:

1. From either side, slide the cutter blade assembly into the cutter bar assembly.

HINTS

- Thoroughly oiling the cutter blade assembly before installing it in the cutter bar assembly will help it slide into place more smoothly.
- When pushing the cutter blade assembly into the cutter bar assembly, frequently check to make sure that neither the end of the cutter blade assembly nor the cutter blade assembly's wear plates are hanging up and preventing the cutter blade assembly from sliding into place.

2. Place the drive pin on top of the cutter blade assembly. Align the bolt holes in the drive pin's base with the two bolt holes in the cutter blade assembly.
3. Install the two 8 MM x 20 MM bolts and lockwashers into the holes. Very securely tighten the two bolts with the 13 MM (or the 1/2-inch) wrench.

Tightening a Loose Individual Blade Section or Ledger Plate

NOTES

- A "ledger plate" is a single "knife" blade on the ledger bar (the lower stationary bar).
- A "blade section" is a single "knife" blade on the cutter bar assembly (the upper bar that oscillates when you engage the Blade Drive Lever).
- Although the term "blade section" appears throughout this instruction, the same procedure is used when tightening a ledger plate.

You'll need a hammer and either a center punch or a flat punch to tighten a loose individual blade section.

1. Remove the cutter bar assembly from the mower. See Page 34 for instructions.

CAUTION

When working on or near the cutter bar blade assembly, wear heavy leather gloves to help prevent the blades from accidentally pinching or cutting your fingers or hands.

Failure to do this could result in personal injury.

2. Remove the cutter blade assembly from the cutter bar assembly. See Page 36 for instructions.

3. Place the portion of the blade that has the loose rivet onto a very sturdy and secure steel object. You'll be using this steel object as an anvil, so it will need to be extremely sturdy and secure.

CAUTION

Wear safety glasses or safety goggles to protect your eyes when tightening the blade's rivets.

Failure to do so could result in personal injury.

4. Position the punch in the middle of the counter-sunk part of the rivet as shown in Photo 5-44.

5. Strike the punch with the hammer.



MAINTENANCE

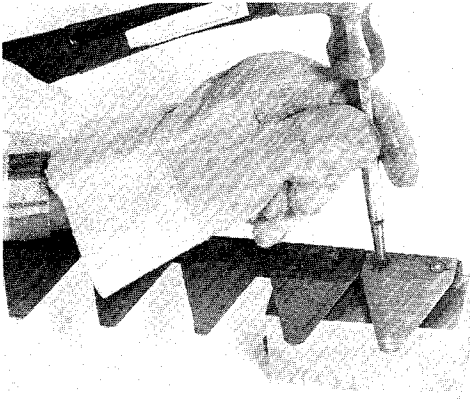

Photo 5-44: Tightening an individual blade section.

6. Check the blade section for tightness. Repeat Steps 3, 4, and 5 if necessary.
7. If the blade section is still loose, try tightening the second rivet that attaches the blade section to the bar.
8. If the blade section cannot be tightened by following this instruction, the loose blade section and rivets should be replaced with new ones.

Replacing an Individual Blade Section or Ledger Plate

NOTES

- A "ledger plate" is a single "knife" blade on the ledger bar (the lower stationary bar).
- A "blade section" is a single "knife" blade on the cutter bar assembly (the upper bar that oscillates when you engage the Blade Drive Lever).
- Although the term "blade section" appears throughout this instruction, the same procedure is used when replacing a ledger plate.

CAUTION

- Before working on or near the cutter bar, shut the engine off, allow it to cool, disconnect the spark plug wire and prevent it from touching the spark plug. For electric start models, also remove the Engine Ignition key from the key-switch.
- When working on or near the cutter bar blades, wear heavy leather gloves to help prevent the blades from accidentally pinching or cutting your fingers or hands.

Failure to do so could result in personal injury or property damage.

To remove a damaged blade:

1. If you're replacing a ledger plate, remove the cutter bar assembly from the mower. If you're replacing a blade section, proceed to Step 2.
2. Remove the cutter blade assembly from the cutter bar assembly.
3. File, grind, or saw off the rounded heads of the two rivets that attach the damaged blade section to the bar.

CAUTION

If you're using a grinding wheel to remove the rivets, wear safety glasses or goggles to protect your eyes.

Failure to do so could result in personal injury or property damage.

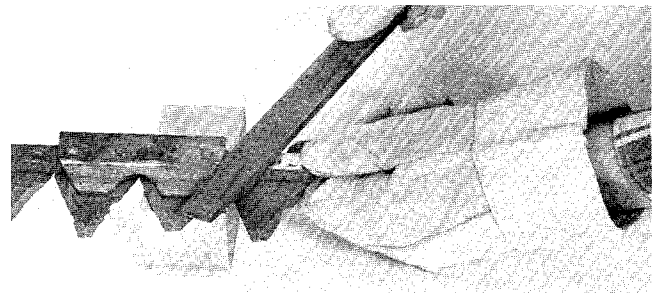

Photo 5-45: Removing the rivet heads.

4. Place the cutter blade assembly on a very sturdy and secure steel object such as an anvil or vise. The steel object must be extremely sturdy and secure. Allow the portion of the blade that you will be driving the rivet out of to extend over the edge of this steel object as shown in Photo 5-46.
5. Place a 3/16-inch punch on the shank of the rivet. Use a hammer to drive the rivet out of the bar.
6. Move the blade so the second rivet being removed is positioned as shown in Photo 5-46. Use the hammer and punch to drive this rivet out of the bar.

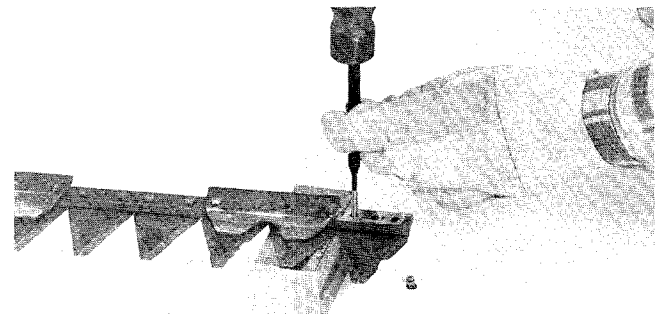

Photo 5-46: Removing the Rivets From the Blade.

To replace a damaged blade:

NOTES

- Three different lengths of rivets are used to attach the various blade sections or ledger plates to the bars:
 - a. The 18 millimeter rivets are used to attach the ledger plates to the ledger bar on the 38-inch bar only.
 - b. The 16 millimeter rivets are used to attach both an individual blade section and a wear plate to the cutter bar. The 16 millimeter rivets are also used to attach a ledger plate to the ledger bar on the 34-inch bar.
 - c. The 14 millimeter rivets are used on both the 34-inch bar and the 38-inch bar to attach only a blade section to the cutter bar.

- Use the three-hole blade to replace either of the (broken) three-hole blades that are located underneath the cutter bar drive pin. Use a two-hole blade to replace any of the other (broken) blades.

- Ledger plates are not interchangeable with the cutter bar blade sections.

1. Place the blade section on the bar. Then insert the correct length rivet (see Notes above) through the holes in the blade section and bar.

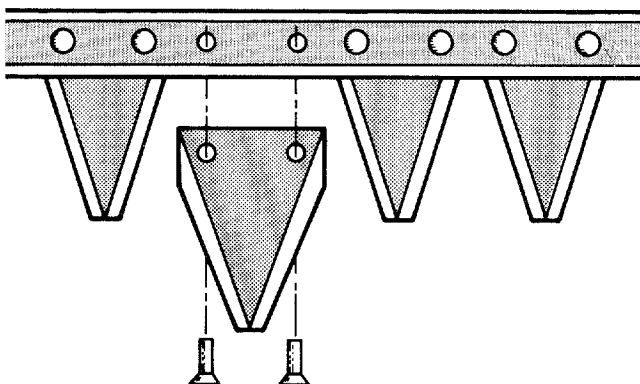

Figure 5-47: Placing a new blade section and rivets on the bar.

2. Place the portion of the bar with the new blade and rivets onto the steel object you used when driving the rivets out of the blade.

3. Use a heavy hammer (preferably a ball peen hammer) to pound the protruding shanks of the rivets into heads.

⚠ CAUTION

When pounding the rivet shanks into heads, wear safety glasses or goggles to prevent any stray chips from hitting your eyes.

Failure to do so could result in personal injury or property damage.

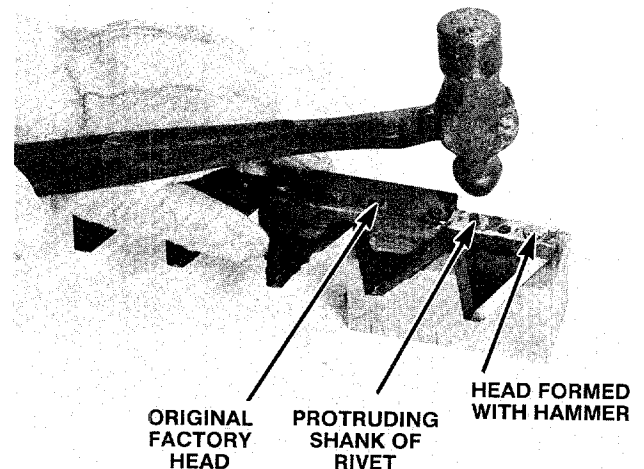

Photo 5-48: Forming the rivet shanks into heads.

4. Check the other end (the countersunk end) of the newly installed rivets. Make sure that these ends are flush with the blade section. If they are not flush, file the countersunk ends until they are flush with the blade section.

5. Slide the cutter bar back into the cutter blade assembly. Move the cutter bar back and forth to make sure that the newly installed rivets don't hang up anywhere. If the newly installed rivets do hang up, use a file to slowly remove any excess metal from the rivet heads until the cutter bar can be moved back and forth without any interference.

6. Reinstall the drive pin on top of the cutter bar. Use a 13 MM (or a 1/2-inch) wrench to evenly and securely tighten the two bolts that hold it in place.

7. Place the drive socket on the drive pin and reinstall the cutter bar assembly on the mower. Refer to Page 34 in this Manual for instructions.



MAINTENANCE

Electric Starting System Maintenance

Battery Charging

The engine on the electric start mower is equipped with an alternator to provide continuous battery charging whenever the engine is running. However, to extend the battery life and to ensure that the battery is always ready for use, we recommend that you follow the battery charging schedule given in "Seasonal Charging" on this page.

⚠ CAUTION

- Before charging the battery, shut the engine off, allow it to cool, disconnect the spark plug wire and prevent it from touching the spark plug, and remove the Engine Ignition key from the keyswitch.
- Do not use a battery charger other than the one that was provided with the TRAIL BLAZER® Mower.
- Do not short circuit the battery wires. (Don't touch the wires together, or touch metal objects from a bare wire or connector to another bare wire or connector.)
- Do not place the battery in an air tight container when charging it.
- Remove all rings and other metal jewelry when working on or near the battery or the electrical system.

Failure to follow these instructions could result in personal injury or property damage.

1. Disconnect the wiring harness plug that is located between the engine and the rear hood.
2. Connect the plug on the battery leads to the plug on the battery charger wires.

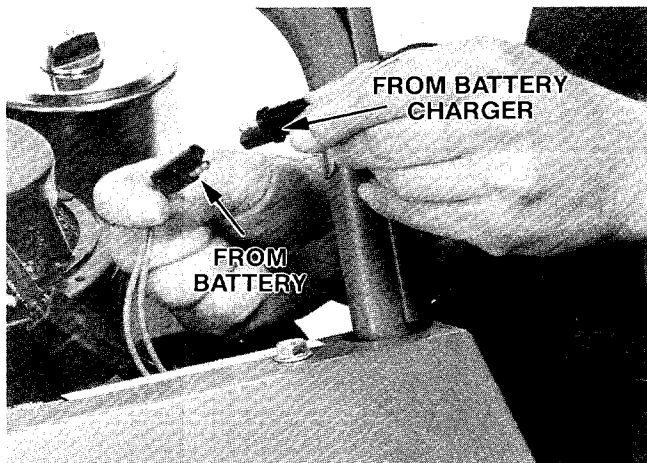

Photo 5-49: Connecting the Battery Charger to the Battery Leads.

3. Plug the battery charger into a 110-volt wall outlet. Allow the battery to charge for 10 hours before you try to start the engine with the Engine Ignition key.

4. After this 10-hour charge, unplug the battery charger from the wall outlet. Then disconnect the battery charger plug from the battery plug.

5. Reconnect the wiring harness that you disconnected in Step 1.

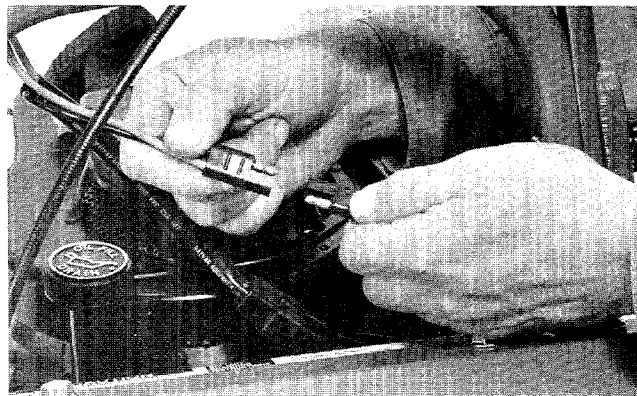

Photo 5-50: Reconnecting the wiring harness plug.

6. After you've finished charging the battery, be sure to store the charger in an easily-remembered location. You will need it to periodically recharge the battery during the mowing season (See "Seasonal Charging".)

Seasonal Charging

To extend the battery's life and to ensure that your electric starting system will always be ready to start the mower's engine, you should periodically charge the battery for 10 hours (each time) as follows:

1. Charge the battery at the beginning of your mowing season.
2. During the mowing season, fully charge the battery at least one time.
3. At the end of your mowing season, fully charge the battery.

You should give the battery a 10-hour charge as part of the steps you take to store the mower. (See "Storage" on Page 42 of this Manual for additional storage steps.)

Battery Removal and Installation

⚠ CAUTION

- Before working on, or near, the electrical system, shut the engine off, allow it to cool, disconnect the spark plug wire and prevent it from touching the spark plug. Remove the Engine Ignition key from the keyswitch.
 - Remove all rings or other metal jewelry.
- Failure to do this could result in personal injury or property damage.

⚠ CAUTION

The mower's battery contains sulphuric acid and other toxic materials.

- Do not damage the battery case. If the case is broken or damaged, avoid contact with battery contents.
- Dispose of battery properly. Check with local authorities for proper disposal methods.

Failure to follow these instructions could result in personal injury or property damage.

To remove the battery:

1. Use a ½-inch wrench to remove the two bolts that attach the rear of the hood to the rear hood. Then loosen the four bolts (two on each side) that secure the sides of the hood to the right and left frame plates. Remove the hood.
2. From behind the rear hood, disconnect the plug on the battery leads from the plug on the mower wiring harness.

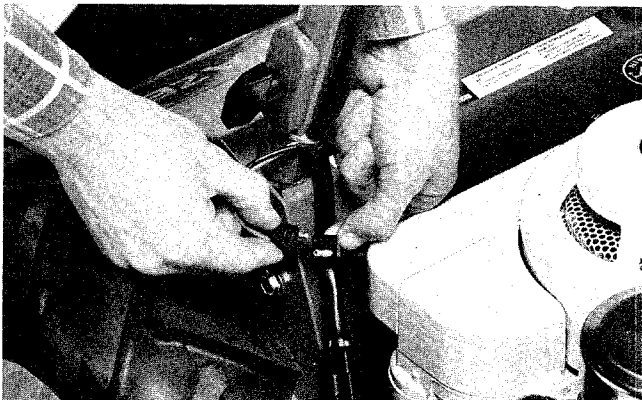

Photo 5-51: Disconnecting the plugs.

3. Push the battery leads and the plug forward, through the hole in the left-hand side of the rear hood.
4. Use a 5/16-inch wrench to remove the bolt that secures the lower front end of the battery clamp to the front of the battery bracket. Take the battery clamp off the mower.

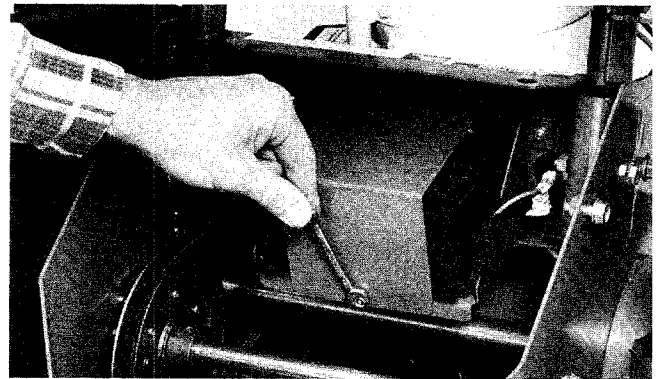

Photo 5-52: Removing the battery clamp bolt.

5. Carefully remove the top battery vibration pad.
6. Lift the battery and bottom vibration pad up, out of the mower.

To install the battery:

1. Inspect both of the battery's vibration pads for damage and deterioration. Replace them if necessary. Also inspect the hole (in the left-hand side of the rear hood) that the battery wires go through—there should be a plastic grommet in this hole to prevent the battery wires from chafing and then short circuiting.
2. Fold the larger battery vibration pad around the battery as shown in Photo 5-53.
3. Fold the smaller vibration pad over the top and forward side of the battery as shown in Photo 5-53.
4. Place the battery in the battery bracket. Make sure that the battery's leads are on the left-hand side. Insert the leads through the hole in the left-hand side of the rear hood.



Photo 5-53: Installing the battery.

5. Place battery clamp over battery. Secure it to the front of battery bracket with previously removed bolt.
6. If the battery needs to be charged, please refer to "Battery Charging" on Page 40 of this Manual.
7. After the battery has been charged, reconnect the plug on the end of the battery leads to the plug on the mower's wiring harness.
8. Reinstall the hood on the mower. Use a ½-inch wrench to securely tighten all six bolts that secure it.

MAINTENANCE

Storage

Whenever the mower will not be used for more than 90 days, you should perform the following steps to ensure that the mower will be ready the next time you use it.

1. Install the plastic blade protector on the blade.
2. Remove all fuel from the tank.
3. Change the engine oil. See Page 19 for instructions.
4. Remove the spark plug and squirt approximately ½-ounce of engine oil into the spark plug hole. Slowly pull the recoil starter rope to crank the engine. Then reinstall the spark plug.
5. Clean any dirt, grass, or chaff from the recoil housing screen and other parts of the engine.
6. Clean the air cleaner elements.
7. Lubricate the mower. See Page 22 for instructions.

8. Thoroughly inspect the mower for any loose, broken, or missing components. Repair them as necessary. Check all bolts to make sure they are tight.

9. Check the tire pressure and adjust as necessary.

10. For electric start models, fully charge the battery.

11. For electric start models, remove the Engine Ignition key from the keyswitch.

12. Disconnect the spark plug wire from the spark plug. Prevent the spark plug wire from touching the spark plug by placing the spark plug wire's boot on its holding tab on the rear of the engine.

13. Don't store the mower in a "nose-up" position. Keep the mower level.

14. Remember, the end of the mowing season is a good time to inspect your mower and order any spare or replacement parts you'll need for the next mowing season.

MAINTENANCE SCHEDULE

	Before Each Use	Every 5 Hours of Operation	Every 10 Hours of Operation	Every 25 Hours of Operation	Every 100 Hours of Operation	As Required	As Noted	Before Storage
Adjust Carburetor.						✓	3	
Check for Oil Leaks.	✓						3	
Check Engine Oil Level.	✓	✓						
Check Operation of Handlebar Levers.	✓							
Clean Air Filter Elements.				✓			1	✓
Change Engine Oil.				✓			1,4	✓
Check (and Adjust if necessary) Wheel Drive Mechanism and Blade Drive Mechanism.	✓		✓				5	
Lubricate Grease Fittings.				✓				✓
Lubricate Mower.				✓				✓
Oil Cutter Bar Blade.		✓					1	✓
Check & Adjust (if necessary) Blade Guides.			✓			✓		
Check Air Pressure in Tires (10-20 psi).				✓				✓
Check All Fasteners.			✓					✓
Inspect Spark Plug.					✓			✓
Recharge Battery.						✓	2	✓
Inspect Spark Arrester on Muffler.	✓						3	
Clean Engine and Engine's Cooling System.					✓	✓	3	✓

¹More frequently if you're operating the mower in a very dusty or dirty environment.

²See also "Seasonal Charging" in the Maintenance Section of this Manual.

³Refer to the Briggs & Stratton Engine Operating and Maintenance Instructions Manual.

⁴Also do this after the initial five hours of engine operation.

⁵You'll also have to perform this maintenance item after the initial 5 hours of mower operation. Also, whenever a belt has been replaced, you'll have to perform this maintenance item after several hours of operation due to the new belt's having become seated on the pulley grooves.

TROUBLESHOOTING CHART

ENGINE PROBLEMS		
TROUBLE	POSSIBLE PROBLEM	SOLUTION
Engine does not start.	Spark plug wire disconnected. Engine Throttle Lever in STOP position. Engine flooded. Fuel tank empty. Air cleaner element(s) excessively dirty. Engine Throttle Lever improperly adjusted.	Reconnect spark plug wire to spark plug. Move lever to correct starting position. Move Engine Throttle Lever to STOP. Pull recoil starter rope several times. Move Engine Throttle Lever to START & try to start engine again. Fill fuel tank. Remove & clean air cleaner element(s). Readjust Engine Throttle Lever.
NOTE: If you have an electric start mower that won't start, please refer to the electric start troubleshooting information at the end of this chart.		
Engine does not start. Engine appears to be frozen. Can only pull recoil starter rope out a short distance.	Crankcase oil has seeped into cylinder, creating a "liquid lock" situation.	Remove spark plug. Pull recoil starter rope several times. Clean & reinstall spark plug. Check engine oil level. Try to start engine again.
Engine runs poorly.	Fouled spark plug. Excessively clogged air cleaner element(s). Engine Throttle Lever mechanism not adjusted correctly. Carburetor is out of adjustment. Stale fuel.	Remove, clean, check, (or replace), re-gap and reinstall spark plug. Remove & clean (or replace) air cleaner element(s). Check & readjust Engine Throttle Lever mechanism. Refer to Briggs & Stratton Operating & Maintenance Instructions for adjustment procedures. Drain fuel tank. Add fresh fuel.
Black smoke comes out of muffler when engine is running.	Excessively clogged air cleaner element(s). Incorrect carburetor adjustment.	Remove, clean, (or replace), and reinstall element(s). Refer to Briggs & Stratton Operating & Maintenance Instructions for adjustment procedures.
White smoke comes out of muffler when engine is running.	Engine has too much oil in its crankcase. Mowing up and down a steep slope. (Oil can seep into cylinder.) Mower was stored with nose up—oil seeped into cylinder & is being burned.	Check engine oil level. Adjust as necessary. Don't mow steep slopes. When all oil in cylinder is burned up, engine exhaust will be normal. Check oil level.
Engine overheats. Paint may be discolored on rear of engine.	Air cooling system clogged.	Clean recoil starter screen. Remove recoil shroud and clean fins.

MOWER PROBLEMS		
TROUBLE	POSSIBLE PROBLEM	SOLUTION
Uneven or poor cut.	Dull or damaged blade sections. Blade guides not adjusted properly.	Replace any dull or damaged blade sections. Readjust blade guides.
Sloping cut.	Height adjusters not set at equal heights.	Re-set height adjusters.
Cutter bar does not oscillate when right-hand handlebar lever is engaged (squeezed).	Too little tension on cutter bar cable. Broken or kinked cutter bar drive cable. Disconnected cutter bar drive engagement spring. Broken or bent blade section or ledger plate. Object wedged in blade. Broken or worn blade drive engagement spring. Worn or broken blade drive belt.	Readjust tension. [See Cutter Bar Drive Adjustment (General).] Replace cutter bar drive cable. Reconnect spring to end of idler arm/ end of blade drive cable. Replace bent blade section or ledger plate. Shut off engine. Remove wedged object. Replace spring. Replace belt.
Cutter bar still oscillates when right-hand handlebar lever is released.	Too much tension on cutter bar drive cable. Belt guide (on bottom of engine deck) has loosened or is bent. Broken or excessively worn idler return spring. Kinked cutter bar drive cable.	Readjust tension on blade drive cable. [See "Cutter Bar Drive (General).] Securely tighten bolts that attach it to bottom of engine deck. If guide is bent, replace it. Replace spring. Replace cable.
Excessive hand pressure required to engage (squeeze) handlebar lever.	Cable tension is too tight. Kinked cable.	Readjust cable tension. [Refer to "Cutter Bar Drive (General) or to Wheel Drive (General).] Replace cable.

MAINTENANCE

TROUBLESHOOTING CHART (continued)

MOWER PROBLEMS (continued)		
TROUBLE	POSSIBLE PROBLEM	SOLUTION
Wheels do not rotate when left-hand handlebar lever is engaged (squeezed).	<p>Not enough tension on wheel drive cable.</p> <p>Worn or broken wheel drive belt.</p> <p>Broken or kinked wheel drive cable.</p> <p>Disconnected wheel drive engagement spring.</p> <p>Broken or worn wheel drive engagement spring.</p> <p>Broken or missing cotter pin on engine PTO pulley.</p> <p>Wheel shaft sprocket bolt missing.</p> <p>Broken jackshaft chain.</p>	<p>Readjust tension. See Wheel Drive Adjustment (General).</p> <p>Replace belt.</p> <p>Replace cable.</p> <p>Reconnect spring to idler arm/end of wheel drive cable.</p> <p>Replace spring.</p> <p>Replace cotter pin.</p> <p>Replace bolt and nut.</p> <p>Replace jackshaft chain.</p>
Wheels continue to rotate when left-hand handlebar lever is released.	<p>Too much tension on wheel drive cable.</p> <p>Broken or excessively worn idler return spring.</p> <p>Kinked wheel drive cable.</p>	<p>Readjust tension on wheel drive cable. [See Wheel Drive Adjustment (General).]</p> <p>Replace spring.</p> <p>Replace cable.</p>
Mower pulls to one side while mowing.	Unevenly inflated tires.	Check tire pressures. Make sure they are inflated to an equal amount (10-20 PSI).
Excessive noise and/or vibration.	<p>Blade guides out of adjustment.</p> <p>Blade section(s) or ledger plate(s) on blade are loose.</p> <p>Loose weed deflector.</p> <p>Loose cutter bar mount.</p> <p>Cracked weed deflector.</p> <p>Loose channel (on drive arm).</p> <p>Loose nut on drive arm pivot bolt.</p> <p>Channel (on drive arm) dry.</p> <p>Worn drive socket rubber bushing/ cutter bar mount.</p> <p>Frozen or broken convex bearing (on top of flywheel).</p> <p>Loose frame bolts.</p> <p>Loose flywheel nut.</p> <p>Engine speed is set too high.</p> <p>Flywheel bearing is broken or frozen.</p>	<p>Adjust blade guides.</p> <p>Use hammer and punch to tighten loose rivets.</p> <p>Tighten the four weed deflector retaining bolts and the three weed deflector support bolts.</p> <p>Tighten the four cutter bar mount retaining nuts & bolts.</p> <p>Replace weed deflector.</p> <p>Check channel for looseness. If loose, remove drive arm, tighten channel, and reinstall drive arm.</p> <p>Re-torque nut to 100 ft.-lbs.</p> <p>Lubricate channel with automotive type grease.</p> <p>Replace drive socket and/or cutter bar mount.</p> <p>Remove drive arm from mower. Replace bearing.</p> <p>Check & tighten all bolts.</p> <p>Re-torque nut to 200 ft.-lbs.</p> <p>Top engine speed should be 3200 RPM. Have Briggs & Stratton Service Center adjust speed.</p> <p>Replace bearing.</p>
Cutter bar does not cut well.	<p>Object jammed in cutter bar.</p> <p>Too little tension on cutter bar drive cable.</p>	<p>Shut off engine. Remove object from cutter bar.</p> <p>Increase tension on cutter bar drive cable. See "Cutter Bar Drive Adjustment (General)".</p>

ELECTRIC START SYSTEM TROUBLESHOOTING

TROUBLE	POSSIBLE PROBLEM	SOLUTION
Keyswitch does not operate starter.	<p>Engine does not turn over well when Engine Ignition Switch is actuated.</p> <p>Wiring harness loose.</p> <p>Corroded connections.</p> <p>Discharged battery.</p> <p>Broken wires in wiring harness.</p> <p>Malfunctioning keyswitch.</p> <p>Malfunctioning starter motor.</p> <p>Loose connections on starter motor.</p> <p>Also refer to "Liquid Lock" on Page 21 of this Manual.</p>	<p>Pull starter rope to make sure engine is not seized and that problem is in starting system.</p> <p>Check wiring harness plugs for tightness.</p> <p>Disconnect wiring harness plugs. Check for and remove corrosion.</p> <p>Charge battery (with supplied charger) for 10 hours.</p> <p>Use continuity tester (or test light) to check for broken wires. Replace wiring harness if wire is broken.</p> <p>Use continuity tester (or test light) on terminals on back of keyswitch to determine if keyswitch is not working.</p> <p>Take mower to authorized Briggs & Stratton Service Outlet.</p> <p>Take mower to authorized Briggs & Stratton Service Outlet.</p>
If, in the course of your troubleshooting, you find that the battery will not charge from engine operation.	<p>Broken wire in engine recharging circuit.</p> <p>Dead battery.</p> <p>Malfunctioning engine recharging system.</p>	<p>Take mower to an authorized Briggs & Stratton Service Center for repairs.</p> <p>Replace battery.</p> <p>Take mower to an authorized Briggs & Stratton Service Center for repairs.</p>
Battery charger does not charge battery.	<p>Broken battery lead.</p> <p>Broken battery charger wire.</p> <p>Malfunctioning battery charger.</p> <p>Dead battery.</p>	<p>Replace battery.</p> <p>Replace battery charger with new original-type battery charger.</p> <p>Replace battery charger with new original-type battery charger.</p> <p>Replace battery.</p>

INDEX

A		Parts Ordering2	O
Air Filter.....19		Service2	Off-Season Storage42
Air Pressure, TiresInside rear cover		Spark Arrester20	Oil, Engine
Arrester, Spark20		Spark Plug21	Adding18
Assembly Steps6		Starting16	Changing19
		Air Cooling System21	Checking engine oil level18
		Stopping17	Typeinside rear cover
		Storage42	Operation15
		Engine Ignition Key14	Ordering parts3
B			P
Battery, Removal & Inst.41			Parts Ordering
Charging40			Mower3
Seasonal Charging40			Engine2
Belt, Cutter Bar, Removal & Inst.29			Pre-start checklist16
Belt, Wheel Drive, Removal & Inst.23		F	
Blade, Cutter Bar, Replacing38		Freight Damageinside front cover	
Tightening37		Frozen Engine(see Liquid Lock)	
Blade Drive Lever12		Fuelinside rear cover, 15	
Blade Guides, Adjustment36			G
			Gasolineinside rear cover, 15
			Grease, Lube. points22
			Guides, Blade35
			H
			Handlebar Height13
			Height, Cutter Bar13
			I
			Ignition Switch, Engine14
			Ignition System, Engine21
			K
			Keyswitch14
			L
			Levers, Handlebar, Control Wheel Drive ...12
			Liquid Lock21
			Lubrication22
			M
			Maintenance18
			Maintenance Schedule45
			Motor Oil,(See "Oil")
			N
			O
			P
			Q
			R
			Recoil Starter14
			Repairs & Adjustments18-42
			S
			Safety Instructions4
			Seasonal Charging, Battery40
			Serial Numbers2
			Spark Arrester20
			Spark Plug21
			Spark Plug Wire, disconnecting5
			Specifications, Mower &
			Engineinside rear cover
			Starting & Stopping Engine16,17
			Stopping Mower17
			Storage42
			T
			Throttle Lever, Engine14
			Tires, Air Pressureinside rear cover
			Troubleshooting Chart43
			U
			V
			W
			Wheel Drive Lever12
			Wheel Drive Adjustment27
			Wheels, Removal & Inst.23
			Wire Form Belt Guide31

SPECIFICATIONS

MOWER

Height:
 With handlebars in low position, approximately 36 inches.*
 With handlebars in high position, approximately 38 inches.*
 Without handlebars, 22¾ inches.*
 *height of cutter bar height adjusters can affect mower height.

Length:
 With handlebars in high position, 60½ inches.
 Without handlebars, 41½ inches.

Width:
 At wheels, 25½ inches.

Bar width (actual cutting width):
 34 inches/38 inches.

Cutting height:
 Adjustable, from 1¼ inch to 5 inches.

Tires:
 4:00 x 8 Bar Tread, tubeless.

Tire Pressure:
 10 PSI to 20 PSI. (Make sure that tires are inflated evenly or the mower will tend to pull to one side.)

Wheel Drive:
 Kevlar (heavy-duty) V-belt and chain drive. Use only an original equipment belt purchased through Troy-Bilt.

Blade Drive:
 Kevlar (heavy-duty) V-belt with flywheel and eccentric drive arm. Use only an original equipment belt purchased through Troy-Bilt.

Handlebars:
 Two position with rubber isolation mounts on lower ends of handlebars.

Cutting capacity:
 Up to ½-inch thick saplings.

ENGINE
 Briggs & Stratton air-cooled, single horizontal cylinder, 3½ or 4 horsepower, vertical crankshaft.

Oil Capacity:
 Approximately 1¼ pints (However, always check the engine oil level with the dipstick rather than adding a given amount of oil.)

Recommended Oil:
 A high-quality detergent oil classified "For Service SF, SE, or SG".

Recommended Oil Viscosity Grades:
 40° F to 100° F: SAE 30W
 0° F to 40° F: SAE 5W30 or SAE 10W30
 -20° F to 40° F: Synthetic 5W-20 or 5W-30

Spark Plug Type:	<i>Champion</i>	<i>Autolite</i>
Short Plug	CJ-8	235
Long Plug	J-8C	295
Resistor Short Plug	RCJ-8	245
Resistor Long Plug	RJ-8C	306

NOTE: If your mower was originally equipped with a resistor spark plug, you should use only a resistor type spark plug for a replacement.

Spark Plug Gap:
 0.030" (.76 MM)

Speeds:
 Idle, 1750 RPM.
 Maximum speed, 3200±100RPM.

Fuel Recommendations:
 Clean, fresh lead-free gasoline with a minimum octane rating of 77. (Leaded gasoline may be used if lead-free is not available.)
 DO NOT mix oil with the gasoline!

Air filter:
 4 HP cleanable paper filter cartridge with a cleanable foam pre cleaner.
 3½ HP cleanable foam filter.

Battery (electric start models only):
 12 volt, 5.0 Ah

Full No-Time-Limit Warranty

What is Covered:

Your TROY-BILT TRAIL BLAZER® Sickle Bar Mower is warranted by Garden Way Incorporated to be free from defects in materials and workmanship. This warranty will remain in effect for the life of the machine and will be transferred automatically to any and all subsequent owners.

We or your authorized dealer will repair or replace, at no cost to you, any part we find to be defective with the exception of the engine, which is warranted separately by the engine manufacturer. Garden Way Incorporated does, however, extend the length of the engine manufacturer's warranty, providing you with coverage for a total of three (3) years. (Call or write to us for a FREE copy of the engine warranty.)

This FULL NO-TIME-LIMIT WARRANTY also applies to all non-powered attachments. Powered attachments are warranted separately by their manufacturers.

If we determine them defective, even parts that wear in normal use, such as belts, bearings, blades, tires, and tines are covered under this warranty and will be replaced or repaired without charge. Failures or malfunctions caused by normal wear and tear, use of unauthorized accessories or attachments, misuse, or accident are not covered.

FULL ONE-YEAR COMMERCIAL USE WARRANTY: If used for commercial, institutional, industrial, rental or demonstrator purposes, the warranty on this product is limited in duration to one (1) year from date of purchase. The engine warranty for commercial use is a LIMITED WARRANTY also in effect for one (1) year from date of purchase. Proof of purchase is required to obtain commercial warranty service.

How to Get Service:

To obtain warranty service, contact Garden Way Incorporated at 102nd Street and 9th Avenue, Troy, New York 12180, or call us TOLL-FREE at 1-800-833-6990, or consult your Yellow Pages for the name of the authorized TROY-BILT product dealer nearest you.

Your Rights Under State Law:

This warranty gives you specific legal rights, and you may also have other rights which vary from state to state.

1900544B (2/92)



Free Manuals Download Website

<http://myh66.com>

<http://usermanuals.us>

<http://www.somanuals.com>

<http://www.4manuals.cc>

<http://www.manual-lib.com>

<http://www.404manual.com>

<http://www.luxmanual.com>

<http://aubethermostatmanual.com>

Golf course search by state

<http://golfingnear.com>

Email search by domain

<http://emailbydomain.com>

Auto manuals search

<http://auto.somanuals.com>

TV manuals search

<http://tv.somanuals.com>