

GARDEN WAY

by **TROY-BILT™**

SAFETY FIRST!

Before operating this equipment, read this Owner's Manual and the separate manual supplied by the engine manufacturer.

Model _____

52065

OWNER'S MANUAL

Trimmer/Mower

- Safety
- Assembly
- Features and Controls
- Operation
- Maintenance
- Parts List

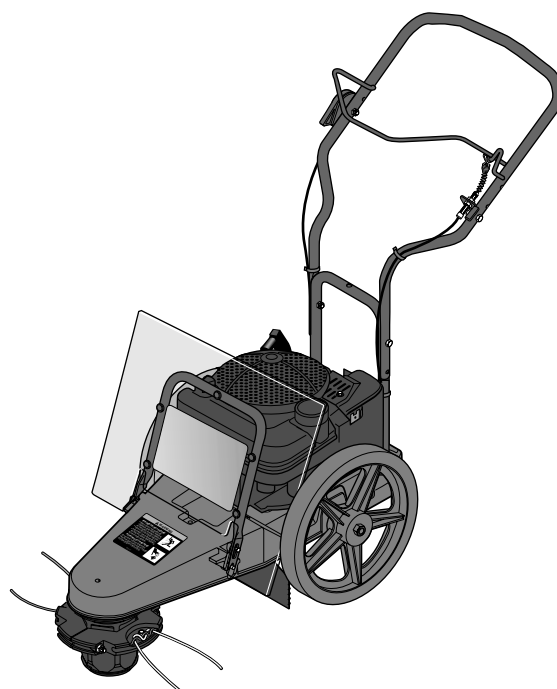

GARDEN WAY INCORPORATED

Dear Owner:

You now own one of the finest trimmer/mowers available. It was designed to easily handle a wide variety of trimming, mowing and clearing chores. You will find the machine to be an invaluable tool in caring for your property.

Please carefully read this Manual which tells you how to safely and easily assemble, operate and maintain your machine. *Be sure that you and any other operators carefully follow the recommended safety practices at all times. Failure to do so could result in personal injury or property damage.*

Of course, if you should ever have any problems or questions, please contact your local authorized service dealer or the Factory.

We want to be sure that you are completely satisfied at all times.

NOTE: Be sure to fill out and return the Warranty Registration Card that was supplied with this Manual.

See Back Cover for Customer Service information

Safety Alert Symbol



This is a safety alert symbol. It is used in this manual and on the unit to alert you to potential hazards. When you see this symbol, read and obey the message that follows it. Failure to obey safety messages could result in personal injury or property damage.



WARNING

The engine exhaust from this product contains chemicals known to the State of California to cause cancer, birth defects or other reproductive harm.

Table of Contents

SECTION 1: SAFETY	3
General Operation	3
Slope Operation	4
Children	4
Service	4
Safety Decals	5
SECTION 2: ASSEMBLY	6
Inspection After Delivery	6
Step 1: Unpacking Unit	6
Step 2: Install Handlebar	6
Step 3: Attach Throttle Control Lever	6
Step 4: Add Motor Oil	6
Step 5: Check Trimmer Head Hardware	6
SECTION 3: FEATURES & CONTROLS	8
SECTION 4: OPERATION	9
Pre-Start Checklist	9
Fill Fuel Tank	9
Adjust Handlebar Height	9
Adjust Line Cutting Height	9
Use the Correct Diameter Trimmer Line	10
Using the Trimmer Head Control Bail	10
Operating the Machine	10
Operating Tips and Techniques	11
SECTION 5: MAINTENANCE	12
Maintenance Schedule	12
Adjusting Trimmer Head Engagement	12
Removing and Replacing the Trimmer Head	12
Inspecting and Replacing the Drive Belt	13
Belt Performance Troubleshooting	14
Lubrication	14
Cleaning the Engine	14
Trimmer/Mower Cleaning and Debris Removal	15
Compact Storage	15
General Engine Maintenance	15
Engine Oil Service	15
Air Cleaner Service	15
Spark Plug Service	15
Spark Arrester Screen Service	15
Engine Cleaning	15
Carburetor/Governor Control Adjustments	15
Throttle Control Adjustment	15
Off-Season Storage	15
Changing Trimmer Lines	16
Troubleshooting	17
Parts List	18
Customer Service Information	Back Cover

SPARK ARRESTER WARNING TO RESIDENTS OF CALIFORNIA AND SEVERAL OTHER STATES

Under California law, and under the laws of several other states, you are not permitted to operate an internal combustion engine using hydrocarbon fuels on any forest, brush, hay, grain, or grass covered land; or land covered by any flammable agricultural crop without an engine spark arrester in continuous effective working order.

The engine on the unit is an internal combustion engine which burns gasoline, a hydrocarbon fuel, and must be equipped with a spark arrester muffler in continuous effective working order. The spark arrester must be attached to the engine exhaust system in such a manner that flames or heat from the system will not ignite flammable material. Failure of the owner/operator of the unit to comply with this regulation is a misdemeanor under California law (and other states) and may also be a violation of other state and/or federal regulations, laws, ordinances or codes. Contact your local fire marshal or forest service for specific information about which regulations apply in your area.

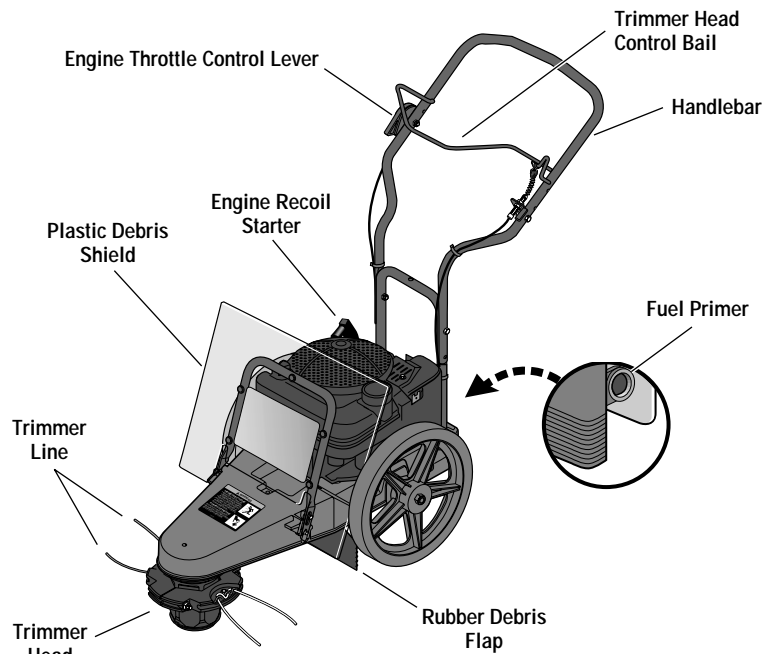

Figure 1-1

IMPORTANT

Safe Operation Practices for Walk-Behind Mowers.

This cutting machine is capable of amputating hands and feet and throwing objects. Failure to observe the following safety instructions could result in serious injury or death.

General Operation

1. Read, understand, and follow all instructions on the machine and in the manuals. Be thoroughly familiar with the controls and the proper use of the equipment before starting.

2. Do not put hands or feet near or under rotating parts. Keep clear of the rotating trimmer head and line at all times.



3. Only allow responsible adults, who are familiar with the instructions, to operate the trimmer/mower. Never let children or untrained adults operate this unit.

4. Inspect the area where the machine is to be used. The machine can propel small objects at high speed, causing personal injury or property damage. Clear the area of objects such as rocks, toys, wire, bones, sticks, etc., which could be picked up and thrown by the trimmer line.

5. Be sure the area is clear of other people (particularly small children and pets) before mowing. Stop machine if anyone enters the area. Keep bystanders at least 50 feet from the area of operation.



6. Do not operate the machine when barefoot or wearing open sandals. Always wear substantial footwear.

7. Wear appropriate clothing such as a long-sleeved shirt or jacket and long trousers or slacks. Do not wear shorts.

8. Do not wear loose clothing—it could catch in the equipment.

9. Do not mow in reverse unless absolutely necessary. Always look down and behind before and while moving backwards.

10. Do not operate the trimmer/mower without proper guards, plates, or other protective safety devices in place.

11. Refer to provided instructions for proper operation and installation of accessories. Only use factory-approved accessories.

12. Stop trimmer head when crossing gravel drives, walks, or roads. Wait for trimmer lines to stop.

13. Stop engine and disconnect spark plug wire from spark plug whenever you leave the unit, clean the unit, or replace trimmer line.

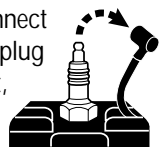

14. Wait until the trimmer head comes to a complete stop, shut the engine off, and disconnect the spark plug wire before installing or removing trimmer line. Be sure the trimmer head is securely attached before operating the machine.

15. Mow only during daylight hours or when good artificial light is available.
16. Do not operate the machine while under the influence of alcohol or drugs, or when tired or ill.
17. Never operate this machine in wet grass. Be sure of your footing; keep a firm hold on the handlebar and walk; never run.
18. Release the Trimmer Head Control Bail before starting the engine.
19. If the unit starts to vibrate abnormally, stop the engine and disconnect the spark plug wire. Check immediately for the cause. Vibration is generally a warning of trouble.
20. Always wear approved safety goggles or safety glasses with side shields when operating machine. The use of any powered machine can result in foreign objects being thrown by high speed rotating parts which can cause personal injury or property damage. Stay away from glass and other easily thrown or breakable objects.
21. Wear work gloves and sturdy footwear when using this machine. Leather work shoes or short boots are ideal—they protect ankles and shins from rocks, pebbles, splinters, etc.
22. It is advisable to wear protective headgear to prevent the possibility of being hit by small flying particles, etc.
23. Before each use, inspect the Throttle Control Lever and its cable. Make sure the cable is free and that the lever functions properly.
24. Watch for traffic when near or when crossing roadways.
25. Never attempt to carry children or other passengers on the machine. They could fall off and be seriously injured, or they could interfere with safe operation of the machine.
26. The machine is equipped with a plastic debris shield in front of the engine and a rubber debris flap under the frame. They must be in place and working properly. Never remove or cause the debris shield or debris flap to cease working. If either of these parts is missing or not working properly, do not use the machine until this situation is corrected.
27. Be aware of where the machine is discharging materials and do not point the discharge at anyone.
28. Never run the engine in an enclosed area. Engine exhaust contains carbon

monoxide, a deadly gas that is odorless, colorless and tasteless. Always run the engine outdoors where there is adequate ventilation.

29. Slow down before turning.
30. Shut off engine when not trimming or mowing.
31. Use extra care when loading or unloading machine into a trailer or truck.
32. Use this equipment for its intended purpose only.
33. Always make sure the handlebars are tight and comfortably positioned. They should never be in an awkward position for the operator.

Slope Operation

Slopes are a major factor related to loss of control and tip-over accidents which can result in severe injury or death. All slopes require extra caution. If you can not back up the slope or you feel uneasy on a slope, do not mow it.

DO:

Mow across the face of slopes; never up and down. Exercise extreme caution when changing direction on slopes. Avoid slopes greater than 15°.

Remove objects such as rocks, tree limbs, etc.

Uneven terrain could overturn the machine. Watch for holes, ruts, or bumps. Tall grass can hide obstacles. Use slow speed.

Use extra care with grass catchers or other attachments. These can change the stability of the machine. Keep all movement on the slopes slow and gradual.

Avoid starting or stopping on a slope.

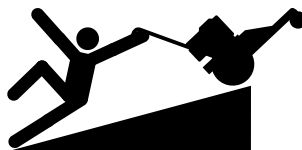

DO NOT:

Do not mow near drop-offs, ditches, or embankments. You could lose your footing or balance.

Do not mow on very steep slopes.

Do not mow on wet grass. Slippery footing can be hazardous.

Children

Tragic accidents can occur if the operator is not alert to the presence of children. Children are often attracted to the machine and the mowing activity. Never assume that children will remain where you last saw them.

1. Keep children out of the mowing area and under the watchful care of a responsible adult.
2. Be alert and turn machine off if children enter the area.
3. Before and while moving backwards, look behind and down for small children.
4. Never allow children to operate the machine.
5. Use extra care near blind corners, shrubs, trees or other objects that may obscure vision.
6. Never carry children, even with the trimmer head stopped. Children may fall off and be seriously injured or interfere with safe machine operation.
7. Do not allow children nearby if you are working.

Service

1. Use extra care in handling gasoline and other fuels. They are flammable and their vapors are explosive. To help prevent a fire or explosion:

- a) Use only an approved container.
- b) Never remove gas cap or add fuel when engine is running. Let engine cool before refueling. Do not smoke.
- c) Never refuel the machine indoors. Fill the fuel tank outdoors and with extreme care.
- d) Never store the machine or fuel container inside where there is an open flame, such as a water heater, etc.
- e) Replace caps on fuel tank and fuel container and clean up spilled fuel before starting engine. Move machine away from any gasoline fumes before starting engine.
- f) Keep matches, smoking materials, open flames, and sparks away from the fuel tank and fuel container.
- g) Leave 1/2" air space at top of fuel tank to allow for fuel expansion.

2. Never run the engine inside a closed area.

- 3. Never clean, or make adjustments or repairs with the engine running. Disconnect the spark plug wire and keep the wire away from the plug to prevent accidental starting. Remove ignition key on electric start models.
- 4. Keep all nuts and bolts tight, especially the trimmer head attachment bolts, and keep equipment in good condition. Check mounting hardware on trimmer head every time you change trimmer line and prior to each use.
- 5. Never tamper with safety devices. Check their proper operation regularly.
- 6. To reduce fire hazard, keep machine free of grass, leaves or other debris build-up. Clean up oil or fuel spills. Let machine cool before storing.
- 7. After striking an object, stop the engine and disconnect the spark plug wire. Inspect the machine and repair, if necessary, before restarting.

- 8. Never make adjustments or repairs while engine is running.
- 9. Components subject to wear, damage and deterioration could expose moving parts or allow objects to be thrown. Frequently check components and replace with factory recommended parts, when necessary. Regularly inspect the trimmer head and debris shield. Make sure they are not bent, damaged or loose.
- 10. Only use eighteen-inch long, .130" or .155" diameter trimmer line. Never use other lengths, diameters or material as trimmer line.
- 11. Trimmer line moves at high speed and can cut. Always stop the engine and let all moving parts stop before replacing the trimmer lines. Let the engine cool.
- 12. Do not change the engine governor setting or overspeed the engine. The governor controls the maximum safe operat-



- ing speed and protects the engine and all moving parts from damage caused by overspeed. Authorized service shall be sought if a problem exists.
- 13. Do not touch engine parts which may be hot from operation. Allow parts to cool completely before inspecting, cleaning or repairing the unit.
- 14. Maintain or replace safety and instructional decals. Refer to the Parts List for replacement decal information.
- 15. Use only original-equipment replacement parts. Parts manufactured by others could present safety hazards and affect performance even though they may fit on this machine.
- 16. Remember—the end of the season is a good time to inspect equipment prior to storage.
- 17. To guard against engine overheating, always keep the engine debris guard mounted and clean.

Safety Decals

Make certain that all safety decals on this equipment are kept clean and in good condition. The decals are shown (at reduced sizes) below. If you need a replacement decal, please refer to the "Parts List" in this manual.

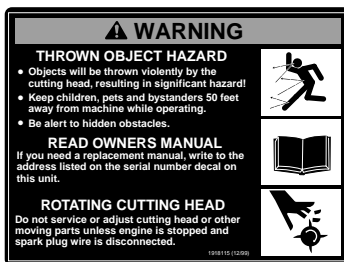

On top of mower deck



On left handlebar



On right handlebar



On right side, rear of mower deck

⚠ WARNING

To prevent personal injury or property damage, do not start the engine until all assembly steps are complete and you have read and understand the safety and operating instructions in this Manual.

INTRODUCTION

Carefully follow these assembly steps to correctly prepare your machine for use. It is recommended that you read this Section in its entirety before beginning assembly.

NOTE: If an assembly step applies only to certain models, those models are noted at the beginning of that step. Otherwise, a step applies to all models.

INSPECTION AFTER DELIVERY

Inspect your machine immediately upon delivery. Be sure that neither the carton nor the contents have been damaged.

If you find or suspect any damage, contact the carrier (trucking company) right away. Inform them of the specific damage and that you wish to file a claim. To protect your rights, be sure to put this in writing to the carrier within 15 days after your machine arrives. Please let us know if you need assistance with this matter.

IMPORTANT: The engine is shipped without motor oil in its crankcase. Motor oil must be added before starting the engine.

NOTE: LEFT and RIGHT sides of the unit are as viewed from the operator's position behind the handlebars.

Tools/Supplies Needed:

- (1) Utility Knife or Scissors
- (2) 1/2" (or adjustable) Wrenches
- (2) 7/16" Wrenches (one with a boxed end)
- Motor Oil (see engine manual for oil specifications and amount needed)

ASSEMBLY STEPS**STEP 1: UNPACKING UNIT**

1. Remove any protective packaging (plastic film and cardboard) from the handlebar and the unit.

2. Carefully remove the handlebar (do not pinch or kink the attached cable) before removing the unit from the carton.

3. Check that you have received the following items:

- Trimmer/Mower Assembly (A, Figure 2-1)
- Extra Trimmer Line (B, Figure 2-1): six each of heavy-duty gauge .130" dia. line and extra heavy-duty gauge .155" dia. line.
- The following are packaged separately:
 - (3) Plastic Cable Tie
 - (1) Hex Hd. Screw, 1/4-20 x 2
 - (1) Hex Locknut, 1/4-20
 - (2) Hex Hd. Screw, 5/16-18 x 1-1/2
 - (2) Hex Locknut, 5/16-18

STEP 2: INSTALL HANDLEBAR

1. Remove the plastic tie and tape that secure the control bail (G, Figure 2-2) to the handlebar (A).

NOTE: Do not pinch or kink the cable that is attached to the handlebar.

2. Carefully lift the handlebars (A, Figure 2-2) to the rear of the unit and align the handlebar legs with the handlebar support bracket (B).

3. Route the trimmer head control cable (C, Figure 2-2) to the outside of the handlebar.

4. Select the low or high height setting holes in the handlebar legs and attach the legs to the support bracket (B) using two 5/16-18 x 1-1/2 hex hd. screws (D) and 5/16-18 locknuts (E).

IMPORTANT: Adjust the handlebars as close as possible to waist level so that your arms are at a comfortable height. This position will result in less pressure on the mower wear cup (located at bottom of trimmer head), making the unit easier to roll and reducing wear to the wear cup.

5. Use two cable ties (F, Figure 2-2) to secure the trimmer head control cable (C) to the handlebar at the locations shown.

STEP 3: ATTACH THROTTLE CONTROL LEVER TO HANDLEBAR

1. The throttle control cable (H, Figure 2-3) is attached to the engine. Gently unwind the cable and position the Throttle Control Lever (I) on the outside of the right handlebar, next to the throttle control decal.

2. Attach the lever with a 1/4-20 x 2 hex hd. screw (J, Figure 2-3) and 1/4-20 hex locknut (K).

3. Use a cable tie (L, Figure 2-3) to secure the cable to the handlebar, as shown.

STEP 4: ADD MOTOR OIL

1. The engine is shipped without motor oil which **MUST BE ADDED** before the engine is started.

2. See the separate engine manual for filling instructions and for oil specifications. The engine must be level when checking the oil level. In ambient temperatures above 40°F, use a high-quality, SAE #30 weight detergent oil classified for Service SF, SG or SH. Use no special additives. Do not mix oil with fuel.

STEP 5: CHECK TRIMMER HEAD HARDWARE

Check that the two bolts (M, Figure 2-4) on the trimmer head are tightened securely. You can rotate the trimmer head, as needed.

IMPORTANT: The trimmer head hardware is permanently installed and is not removable. Do not attempt to replace the hardware.

NOTE: The hole in the top, front end of the mower deck is an access point that allows the trimmer head assembly to be serviced.

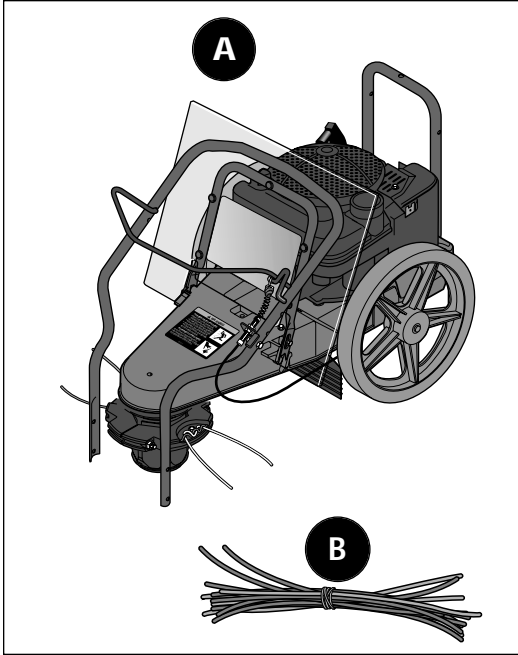

Figure 2-1

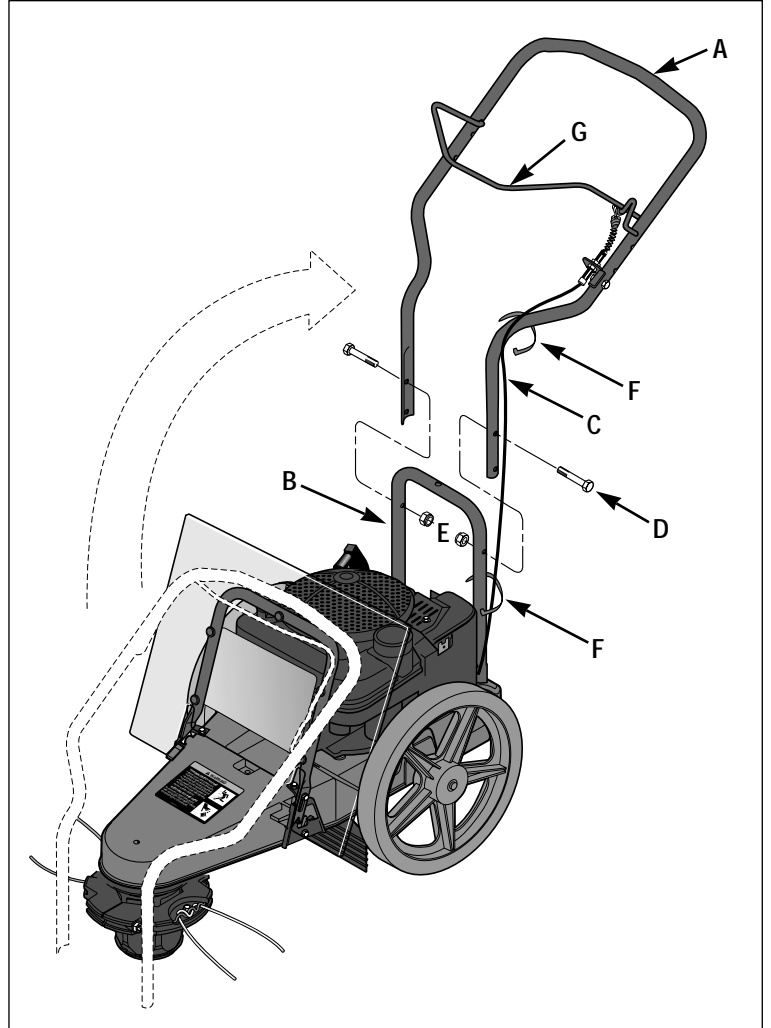

Figure 2-2: Handlebar installation.

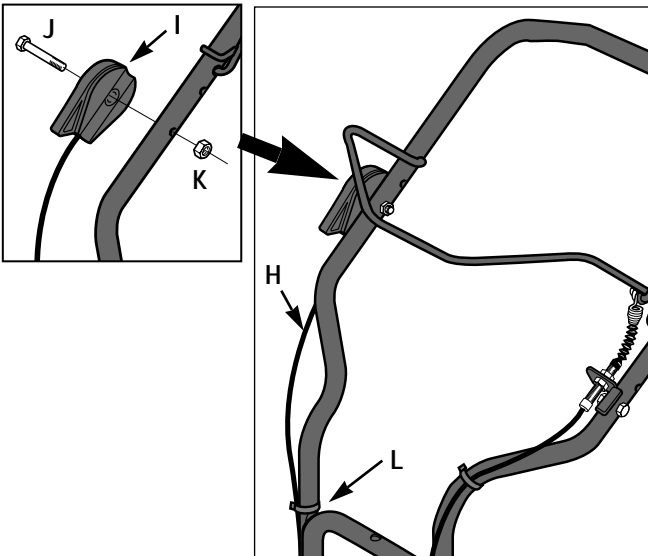

Figure 2-3: Attach throttle lever to right-side handlebar.

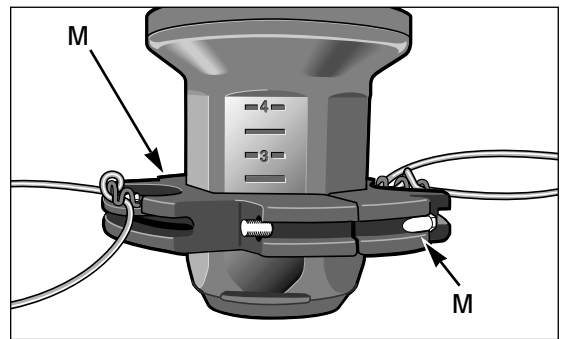

Figure 2-4: Check trimmer head hardware for tightness.

Features and Controls

⚠ WARNING

Before operating your machine, carefully read and understand all safety, controls and operating instructions in this Manual, the separate Engine Owner's Manual, and on the decals on the machine.

Failure to follow these instructions can result in serious personal injury.

INTRODUCTION

This Section describes the location and function of the features and controls on your machine. Refer to Section 4: "Operation" for detailed operating instructions.

IMPORTANT: Refer to the separate engine manual for detailed information about the controls on the engine.

FEATURES AND CONTROLS

Trimmer Head Control Bail

Pull the control bail (A, Figure 3-1) up against the handlebar (engage bail) to start rotation of the trimmer head. Let go of the control bail (disengage bail) to stop the trimmer head.

Cutting Height Settings

The trimmer head (B, Figure 3-1) is adjustable to an infinite number of height settings from 1-1/2" to 4-1/2" (see "Adjust Line Cutting Height" in Section 4).

Trimming Line Mounting Plates

The two trimming lines (C, Figure 3-1) are secured to wire-looped line holders. Replacing the trimmer lines is easy (see "Changing Trimmer Lines" in Section 5).

Handlebar Height Adjustment

The handlebar (D, Figure 3-1) has two height settings (see "Adjust Handlebars" in Section 4).

Plastic Debris Shield

A heavy-duty plastic shield (E, Figures 3-1 and 3-1A) prevents debris build-up on the engine. The shield tilts forward for access to the engine.

Operating Symbols

Various symbols (shown here, with word descriptions) are used on the unit.



ENGINE STOP



SLOW



FAST



STOP



TRIMMER HEAD



ENGAGE BAIL



DISEN- GAGE BAIL

Engine Throttle Control Lever

Use this lever (F, Figure 3-1) to change engine speeds and to stop the engine. The throttle settings are shown on a decal next to the lever.

Engine Recoil Starter

The recoil starter (G, Figure 3-1) is used to pull start the engine.

Fuel Primer Button

The fuel primer button (H, Figure 3-1) allows a cold engine to be primed for faster, easier starting.

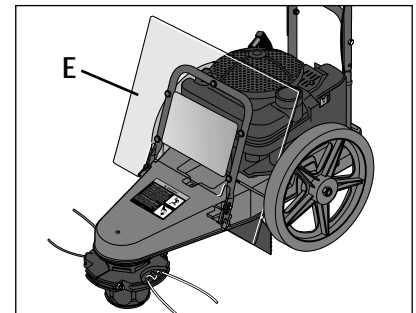

Figure 3-1A: Debris shield in operating position.

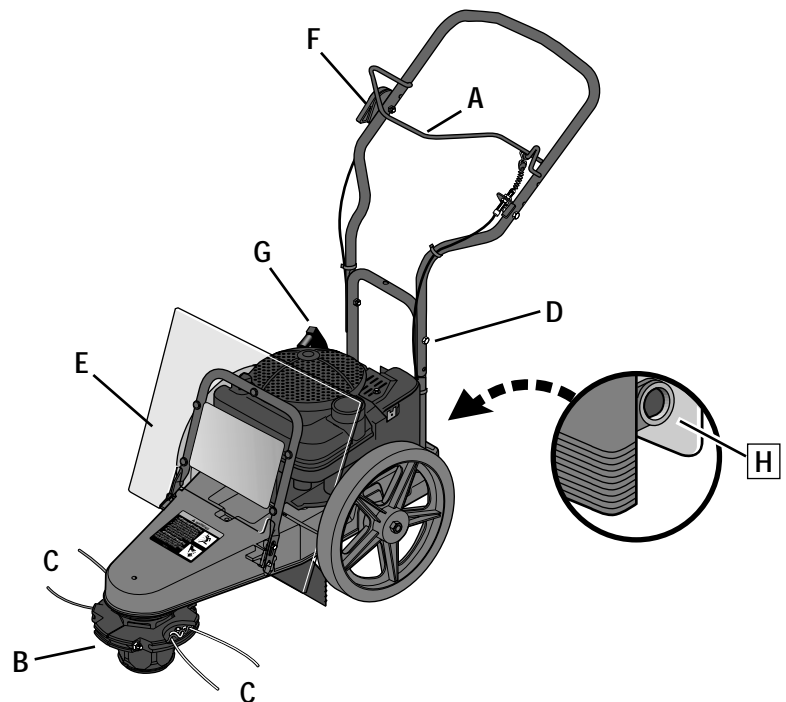

Figure 3-1: Features and controls

⚠ WARNING

Before operating your machine, carefully read and understand all safety, controls and operating instructions in this Manual, in the separate Engine Owner's Manual, and on the decals on the machine.

Failure to follow these instructions can result in serious personal injury.

INTRODUCTION

Read this Section thoroughly before starting the engine. As with any piece of outdoor power equipment, getting the "feel" for how the machine operates and knowing the best techniques for particular jobs are important to overall good performance.

NOTE: References to LEFT, RIGHT, FRONT and REAR of the unit are determined by standing in the operator's position.

PRE-START CHECKLIST

1. Review Section 1: "Safety" and Section 3: "Features and Controls".
2. Check for loose or missing hardware. Tighten or replace as needed.
3. Check that the engine oil level is up to the "FULL" mark on the dipstick. (See engine manual for instructions.)
4. Check the fuel level. (See engine manual and this page for instructions.)
NOTE: Clean debris from around fuel cap, oil dipstick and engine (see "Cleaning Debris" in engine manual) before checking oil level or adding gasoline.
5. Check the Trimmer Head Control Bail and the Engine Throttle Control Lever for freedom of movement.
6. Select the cutting height (see "Adjust Line Cutting Height" in this Section).
7. Check handlebar height position.
8. Carefully check the area to be trimmed and remove any debris.
9. Install the correct diameter trimmer line (see "Use the Correct Diameter Trimmer Line" in this Section).
10. Attach the spark plug wire to the spark plug.

FILL FUEL TANK**⚠ DANGER**

GASOLINE IS HIGHLY FLAMMABLE AND ITS VAPORS ARE EXPLOSIVE.

Follow gasoline safety rules in this Manual (see Section 1) and in the separate Engine Owner's Manual.

Failure to follow gasoline safety rules and instructions can result in serious personal injury and property damage.

1. Lift and tilt plastic debris shield (E, Figure 3-1) forward.
2. Clean fuel fill area and engine (see "Cleaning Debris" in engine manual) each time before fuel is added.
3. Fill the fuel tank with gasoline according to the directions in the engine manual. Follow all instructions and safety rules carefully.
4. Securely replace the fuel tank cap and the fuel container cap. Promptly wipe up any fuel spills.
5. Lift and tilt the debris shield back, then push it down to secure it.

ADJUST HANDLEBAR HEIGHT**⚠ CAUTION**

Before adjusting handlebar height, stop engine and wait for all moving parts to stop, disconnect spark plug wire and prevent it from touching spark plug.

Failure to comply could result in personal injury or property damage.

To adjust handlebar height, refer to "Install Handlebars" in Section 2.

ADJUST LINE CUTTING HEIGHT

The cutting height of the trimmer line can be adjusted between 1-1/2" to 4-1/2". We recommend that you start at a higher setting and make adjustments as needed.

In general, use higher settings to handle taller material and to cope with tougher cutting conditions. Use any trimming height for less demanding conditions.

⚠ CAUTION

Before adjusting the cutting height, shut off the engine, wait for all moving parts to stop, allow the engine to cool, disconnect the spark plug wire and prevent it from touching the spark plug.

Failure to comply could result in personal injury or property damage.

To adjust the cutting height:

1. The cutting line height can be changed when the wear cup is in contact with the ground. If necessary, you may tip the unit back slightly for a better view (do not tip unit all the way back or motor oil may flow to the exhaust area and the engine may smoke for several seconds when started).
2. Use a 1/2" wrench to loosen the two bolts (not the nuts) located on opposite sides of the trimmer head (A, Figure 4-1).
3. The cutting heights are marked on the side of the spindle head (Figure 4-2). Move the top of the trimmer head to the desired setting.
4. Tighten both trimmer head bolts securely (to 75 in/lbs.) and evenly.

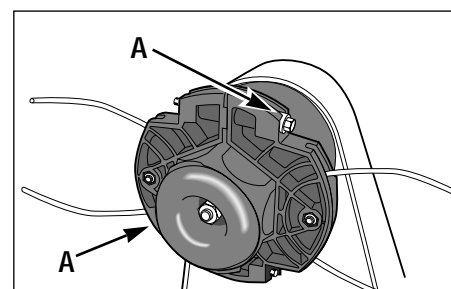

Figure 4-1

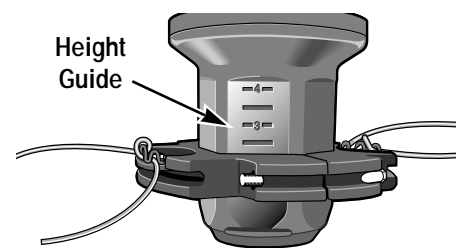

Figure 4-2

USE THE CORRECT DIAMETER TRIMMER LINE

Before starting a project, look at the grass or material you will be cutting.

For tougher conditions, use two (or four) sections of the thicker gauge, .155" diameter extra-heavy duty line. For less demanding conditions, use two sections of the thinner gauge, .130" diameter heavy-duty line. The thicker line has the heft to chop through tougher materials, while the thinner line provides a more precise cut. To change trimmer lines, refer to "Changing Trimmer Lines" in Section 5.

NOTE: The thinner line is also recommended for use near trees or ornamentals to help prevent girdling (cutting the bark).

USING THE TRIMMER HEAD CONTROL BAIL

Before starting the engine, know how to use the Trimmer Head Control Bail.

1. The Trimmer Head Control Bail (A, Figure 4-3) is used to start and stop trimmer head rotation.
2. When starting the engine, always have the control bail in the disengaged (released) position to prevent the trimmer head from turning when the engine starts.
3. When the engine is running, pull the control bail up against the handlebar to start rotation of the trimmer head.
4. Let go of the control bail to stop the trimmer head. The control bail should spring forward to the disengaged position. If it doesn't, do not use the machine until the control bail has been repaired.

WARNING

If the trimmer head control bail is not operating properly, shut off the engine, disconnect the spark plug wire and move the wire away from the plug.

Adjust or repair the control bail before using the trimmer/mower.

Failure to follow this instruction could result in personal injury or property damage.

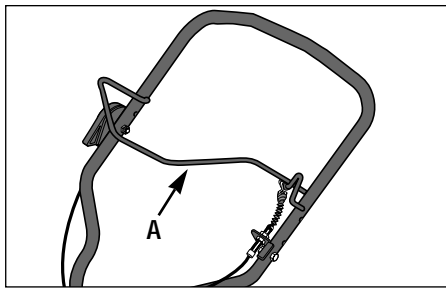

Figure 4-3: Control bail.

OPERATING THE MACHINE

Once you have read and understood the sections in this Manual on "Safety," "Assembly," "Features and Controls," and "Operation," you are ready to operate your machine.

CHECKLIST BEFORE STARTING

1. Complete the "Pre-Start Checklist" in this Section. You must wear safety glasses or goggles.
2. Check the trimmer line cutting height (see "Adjust Line Cutting Height" in this Section).

STARTING THE ENGINE

1. Move the unit to the work area.
2. Connect the spark plug wire to the spark plug.
3. Put on safety-approved eye protection.
4. Release (disengage) the Trimmer Head Control Bail (A, Figure 4-3).
5. Start the engine:
 - a) Put Engine Throttle Control Lever in FAST (rabbit symbol) position.
 - b) Push in fuel primer button as instructed in Engine Owner's Manual. NOTE: Do not use primer to restart a warm engine after a short shutdown.
 - c) Pull recoil start rope slowly until resistance is felt. Then pull rope out rapidly to start engine. Let rope back in slowly. NOTE: If engine fails to start after three pulls, repeat steps b and c.

TO START THE TRIMMER HEAD

1. Stand in the operator's position directly behind the handlebars.
2. Slowly close the Trimmer Head Control Bail (Figure 4-3) against the handlebars to activate the trimmer head. Use the Engine Throttle Control Lever to adjust the speed of the trimmer head.
3. Once the trimmer head is revolving, push the unit along the path to be cut.

TO STOP THE TRIMMER HEAD

Let go of the Trimmer Head Control Bail. The bail will return to its open position and the trimmer head will stop turning.

TO STOP THE ENGINE

Put the Engine Throttle Control Lever in the STOP position. (If time allows, first move the throttle lever to the SLOW setting before stopping the engine.)

NOTE: If the unit is operated in a stationary position with the wear cup in contact with dry vegetation, significant heat will result that may deform the plastic spindle or scorch the vegetation.

WARNING

THROWN OBJECT HAZARD!

- Objects such as rocks, pebbles, and small debris will be thrown violently by the cutting head, resulting in significant hazard to eyes and exposed body parts.
- Always wear safety-approved eye protection and suitable clothing and footwear.
- Keep children, pets and bystanders 50 feet away from machine while operating.
- Be alert to hidden obstacles.

Failure to comply could result in injury or property damage.

OPERATING TIPS & TECHNIQUES

Tips for Precision Cutting			Use Extreme Caution on Slopes		
<p>For the most precise cutting possible, be sure to select the appropriate line cutting height and trimmer line size (thickness) for the conditions at hand.</p> <p>When mowing, let the cutting head rest lightly on the ground, without lifting up or pushing down on the handlebars. This technique allows the cutting head to follow the ground contour closely, resulting in the most even cut possible.</p> <p>Also, be sure to ease into heavy growth to prevent overwhelming the machine.</p>			<p>When operating on sloping ground, use extreme caution and common sense to avoid possible injury or property damage.</p> <p>Do not mow on excessively steep slopes! Avoid slopes if greater than 15° or wherever footing is unsure. If a slope is difficult to stand on, it is probably too steep to trim or mow. In this case, it may be wiser to establish a permanent ground cover on this area.</p> <p>Do not trim on slopes when the ground is slippery. Trim across the face of a slope, not up and down. Slow down and exercise caution when changing direction on slopes.</p>		
Trim When Wet or Dry	<p>Grass and most other materials are most efficiently trimmed when dry. But the unit will do a fine job even with damp or wet materials. When conditions are moist or damp, be sure to clean debris off the machine regularly to keep cutting efficiency high. And watch your footing!</p>				
Clean the Unit On a Regular Basis	Do Not Let the Trimmer Lines Become Too Short	Keep the Mowed Side On the Right While Moving Forward			
<p>Clean under the mower deck frequently to remove any debris buildup. Also clean around the muffler and on top of engine.</p> <p>See the cleaning instructions in Section 5: "Maintenance."</p>	<p>When the trimmer lines wear to less than 1/2 their original length, trimming jobs will take far longer than necessary. As a general guideline, install new lines when they wear to 1/2 their original length.</p>	<p>The trimmer/mower discharges cut materials to the right side.</p> <p>For best results, stay on the right side of unmowed growth as you move along.</p>			
Vary the Throttle Setting According to Conditions				Use the Correct Walking Speed	
<p>The majority of trimming and mowing jobs will yield the best results if the throttle control is set at the fastest speed.</p> <p>Less demanding jobs (and projects that require very precise cutting) will yield better results if the engine speed is somewhat reduced. For example, damage to trees and ornamentals can be avoided by reducing the engine speed, using the lighter .130" diameter line, and by keeping a safe distance away.</p> <p>Again, once you begin a particular job and get a "feel" for the conditions, you will be able to make adjustments for the best possible results.</p>			<p>Use a travel speed that is suitable for the conditions at hand.</p> <p>For example, you'll get better trimming and mowing results at slower walking speeds if the grass is tall or lush.</p> <p>Shorter grass or less dense growth can be cut at faster travel speeds.</p>		

⚠ WARNING

Before inspecting, cleaning or servicing the machine, shut off engine, wait for all moving parts to come to a complete stop, disconnect spark plug wire and move wire away from spark plug. Remove ignition key on electric start models.

Failure to follow these instructions can result in serious personal injury or property damage.

MAINTENANCE SCHEDULE

PROCEDURE	NOTES
Check motor oil level	2, 3
Check trimmer/mower lines	2, 6
Check trimmer head engagement	2
Clean machine	2, 7, 8
Check nuts and bolts	2
Change motor oil	1, 11
Service air filter system	4, 11
Clean under deck	4
General lubrication	4
Inspect drive belt	5
Clean engine	2, 10
Check trimmer head wear cup	3, 9

NOTES

- 1 - After first 2 hours of break-in operation; every 25 hours thereafter.
- 2 - Before each use.
- 3 - Every 5 operating hours.
- 4 - Every 25 operating hours.
- 5 - Every 100 operating hours.
- 6 - New line replacement is suggested when old line is 50% or less of original length.
- 7 - Clean daily in extremely dusty or dirty conditions.
- 8 - See Engine Owner's Manual for service recommendations.
- 9 - Replace when severe gouges exist on bottom surface
- 10 - At each fuel refill.
- 11 - Service more often if used in extremely dusty or dirty conditions (see Engine Owner's Manual).

NOTE: LEFT and RIGHT sides of unit are as viewed from operator's position behind the handlebars.

ADJUSTING TRIMMER HEAD ENGAGEMENT

The tension on the drive belt must be correct for proper operation of the trimmer head. If the tension is correct, the trimmer head will rotate when the Trimmer Head Control Bail is pulled back against the handlebar (another indication of correct tension is if the engine stalls when the trimmer head becomes bound up in very tough material).

A worn or loose drive belt will cause the trimmer head to move slowly – or not at all – when the control bail is engaged (belt squealing may also be noticeable).

If the tension is too tight, the trimmer head may rotate before the control bail is engaged, or when there is no free play in the control bail.

To Adjust Belt Tension

1. Stop the engine and wait for all parts to stop moving. Adjust the two jam nuts on the control cable adjustment stud (see Figure 5-1) as follows:

- a. To tighten belt tension, thread the upper nut (A, Figure 5-1) upward one or two full turns, followed by the lower nut (B). Tighten both nuts securely. Test unit and readjust jam nuts as needed.
- b. To loosen belt tension, thread the lower nut (B) downward one or two full turns, followed by the upper nut (A). Tighten both nuts securely. Test unit and readjust jam nuts as needed.

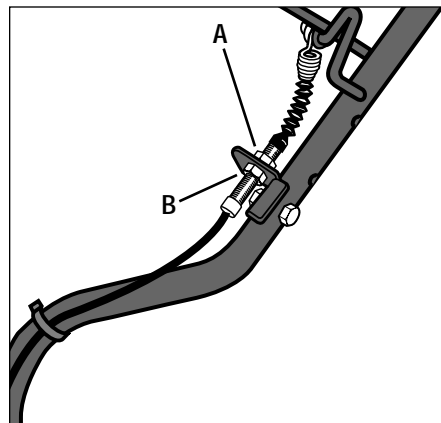

Figure 5-1

REMOVING AND REPLACING THE TRIMMER HEAD

1. Stop the engine and wait for all moving parts to stop. Disconnect the spark plug wire and move it away from the spark plug. Remove the ignition key on electric start models.

2. Two bolts (A, Figure 5-2) secure the trimmer head (B) to the spindle head (C). Loosen both bolts (not the nuts) just enough to allow the trimmer head to slide down the spindle head and past the two stops. Do not attempt to remove the bolts – they are permanently attached. NOTE: It may be necessary to remove the wear cup (D, Figure 5-2) when replacing the trimmer head. See Step 4 for instructions.

3. Install the new trimmer head on the spindle head. Tighten the hardware securely (to 75 in/lbs.) and evenly.

4. Inspect the wear cup (D, Figure 5-2) for signs of severe wear, such as deep gouges. Use the following steps if the wear cup needs to be replaced:

- a. Insert a Phillips head screwdriver into the small hole at the top, front of the deck (see Figure 5-5) and rotate the trimmer head until the screwdriver engages a hole in the trimmer head. This will prevent the trimmer head from turning when you next remove the hex nut (E, Figure 5-2).

- b. Remove hex nut (E), washer (F) and wear cup (D). Install the new wear cup and reinstall the washer and hex nut. Tighten securely and remove Phillips screwdriver from deck.

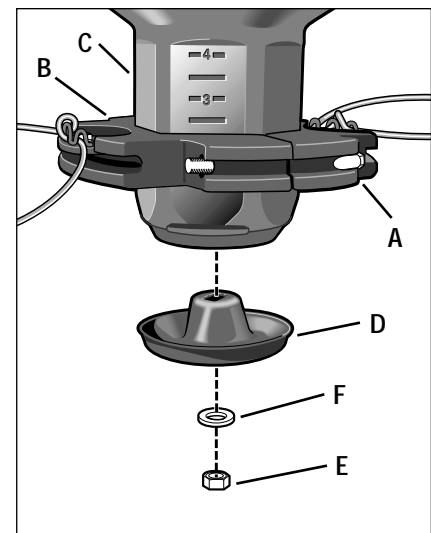

Figure 5-2

WARNING

Before inspecting, cleaning or servicing the machine, shut off engine, wait for all moving parts to come to a complete stop, disconnect spark plug wire and move wire away from spark plug. Remove ignition key on electric start models.

Failure to follow these instructions can result in serious personal injury or property damage.

INSPECTING AND REPLACING THE DRIVE BELT

The drive belt can be inspected or replaced from beneath the machine deck. The belt should not require inspection for many hours of operation. If replacement becomes necessary, follow the instructions given here.

Belt Inspection

Stop the engine and let all moving parts stop. Disconnect the spark plug wire and move it away from the spark plug. Remove the ignition key on electric start models.

1. For convenience, we recommend that you place the unit on a raised platform to make it easier to access the underside of the deck.
2. Remove the rubber debris flap (A, Figure 5-3) by removing one of the small E-rings (B) at the ends of the retainer rod and then sliding the retainer rod out.
3. Remove the rear belt cover by using a 1/2" wrench to remove the screw (C, Figure 5-3) in the rear belt cover. Examine the belt. Feed it around the rear (engine) pulley so the entire belt can be examined. If cracks or other damage are noted, a new belt is needed. Otherwise, clean and reinstall the belt cover and debris flap.

Belt Replacement

4. Remove the spindle head by taking off the hex nut (A, Figure 5-4) at the bottom of the spindle, using a 3/4" socket wrench. (While loosening the nut, prevent the spindle head from turning by inserting a screwdriver or rod into hole B, Figure 5-5, at the top-front of the deck. Be sure to align one of four holes in the pulley with the deck hole first.)

5. With a 1/2" wrench, remove the screw (D, Fig. 5-3) from the front belt cover-spindle mounting plate. Then remove the other four screws securing the belt cover-spindle mounting plate (E, F, G and H, Fig. 5-3). Carefully lower the drive housing and the belt cover-spindle mounting plate. Note precisely how the belt is routed along the pulleys. (See Figure 5-6.) Slip the belt off the rear pulley (H, Figure 5-6), then off the other pulleys. NOTE: The nut on the idler arm V-pulley must be removed in order to take off the belt (the screw may need to be held with an Allen wrench). Install the new belt along the exact same path.

6. Clean parts of all debris. Replace the lower drive shaft housing and front belt cover-spindle mounting plate, the spindle head, the wear cup, the rear belt cover, and the debris flap.

7. Check for correct belt tension. See "Adjusting Trimmer Head Engagement" in this Section.

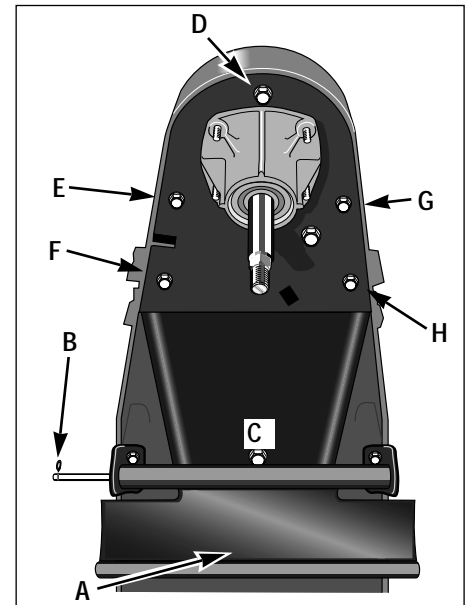

Figure 5-3

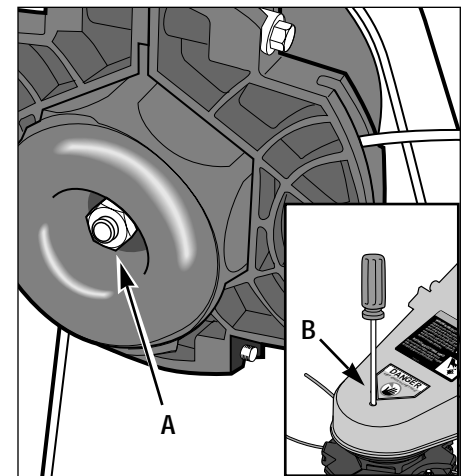

Figure 5-4

Figure 5-5

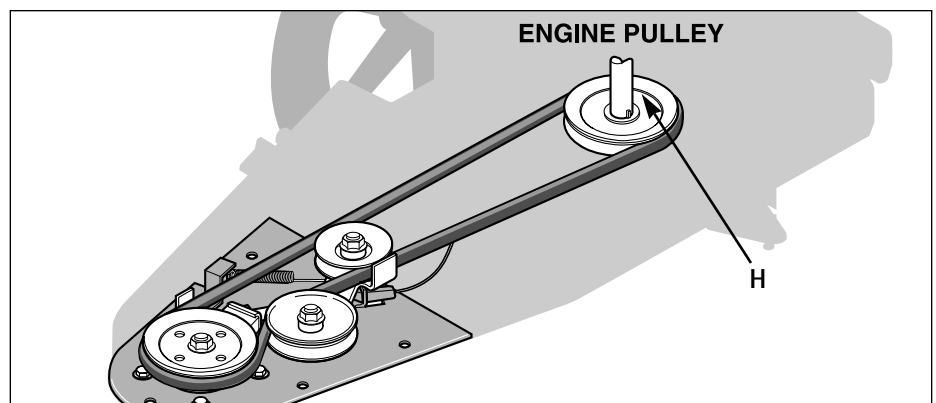
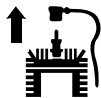

Figure 5-6

WARNING

Before inspecting, cleaning or servicing the machine, shut off engine, wait for all moving parts to come to a complete stop, disconnect spark plug wire and move wire away from spark plug. Remove ignition key on electric start models.

Failure to follow these instructions can result in serious personal injury or property damage.

BELT PERFORMANCE TROUBLESHOOTING

Poor belt performance (noise, overheating, cracking, etc.), can be caused by several conditions. Follow the steps below to correct belt performance problems. Also use these checks after installing a new belt. After shutting the engine off and disconnecting the spark plug wire, remove the rear belt cover on the underside of the machine (refer to previous page). Release the Trimmer Head Control Bail to remove all belt tension.

1 – Belt must be routed between pulleys and guides.

Examine inside surface of belt. If it is cracked or peeling, unbolt and lower the spindle mounting plate and proceed with this step. The pulley system has two belt guides (see Figures 5-7 and 5-8) – the belt must run between the pulleys and the guides. If it doesn't, reroute it as shown. Use masking tape to temporarily hold the belt in place while reattaching the spindle mounting plate.

2 – Minimum clearance is 1/4" on each side between rear belt guide and pulley.

If the rear belt guide (Figure 5-8) is less than 1/4" from the sides of the pulley when the Trimmer Head Control Bail is engaged, loosen the belt guide hardware and move the guide to create a clearance of at least 1/4". Tighten the hardware securely.

3– Both idler pulleys must be mounted right-side up.

Check that the two idler pulleys shown in Figure 5-9 are correctly installed – note that the longer hub on each pulley is against the idler arm. If the pulleys are upside-down, turn them over and tighten them securely.

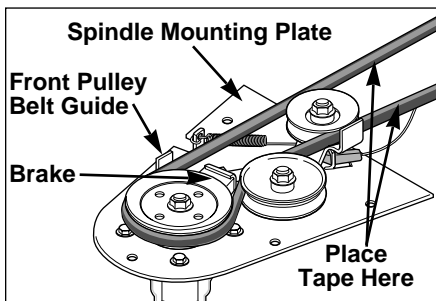

Figure 5-7

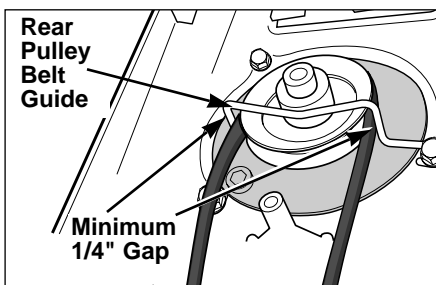

Figure 5-8

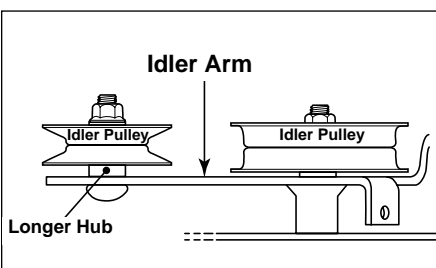

Figure 5-9

LUBRICATION

Apply light oil or a silicone-based lubricant to the following locations:

- Throttle control cable
- Control bail cable
- Nuts, bolts and other hardware

NOTE: The spindle head is permanently lubricated at the factory. There is no need for additional lubrication.

CLEANING THE ENGINE

Before each use of the machine and at each refueling, clean grass, chaff or accumulated debris from the finger guard area (A, Figure 5-10) on top of the engine, and from the linkage, springs and controls on the engine. Keep the area around and behind the muffler free of any combustible debris. See "Cleaning Debris" in the Engine Owner's Manual for complete cleaning instructions. Do not use water to clean engine parts as water could contaminate the fuel system. Use a brush or dry cloth. Be sure engine is cool before cleaning around muffler area.

NOTE: The separate engine air cleaner must also be serviced according to the instructions in the Engine Owner's Manual.

WARNING

Engine parts must be kept clean to reduce the risk of overheating and ignition of accumulated debris. This especially important if cutting tall grass. Clean accumulated debris at each refueling and before each use of the machine.

Failure to comply can cause injury or property damage.

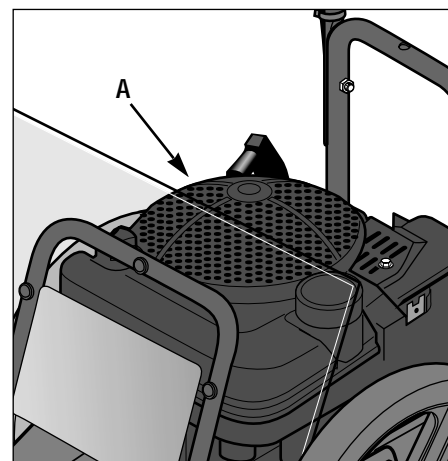

Figure 5-10

⚠ WARNING

Before inspecting, cleaning or servicing the machine, shut off engine, wait for all moving parts to come to a complete stop, disconnect spark plug wire and move wire away from spark plug. Remove ignition key on electric start models.

Failure to follow these instructions can result in serious personal injury or property damage.

TRIMMER/MOWER CLEANING AND DEBRIS REMOVAL

Regular cleaning of debris from around the engine and on the machine is required for maximum engine efficiency and good overall performance. Inspect and clean the following areas regularly, making sure the engine is stopped – and cool – before proceeding:

- Brush and wipe off all engine surfaces, especially before checking oil or adding fuel. Do not let oil or grease accumulate. For access to the front of the engine, the debris shield can be lifted up and tilted forward.
- Wipe the deck clean, particularly near the engine muffler.
- Clean the underside of the deck.
- Keep safety and operating decals clean and legible.
- Keep all control levers clean so they work properly.

COMPACT STORAGE

For compact storage, remove the two screws and locknuts securing the handlebar and carefully (to avoid kinking the cables) rotate the handlebar so that the upper portion rests on the engine and the handlebar legs face to the rear of the unit.

GENERAL ENGINE MAINTENANCE

Perform the following engine maintenance for your engine according to the engine maintenance schedule and instructions in the separate Engine Owner's Manual:

Engine Oil Service – Check the engine oil level before starting the engine and after each 5 hours of continuous operation. Running the engine when it is low on oil will quickly ruin the engine.

Change the oil after every 25 hours of operation and more often when operating in extremely dirty or dusty conditions.

Air Cleaner Service – The air cleaner filters dirt and dust out of the air before it enters the carburetor. Operating the engine with a dirty, clogged air filter can

cause poor performance and damage to the engine. Never operate the engine without the air cleaner installed. Inspect and service the air cleaner after every 25 operating hours, more often if operating in very dusty or dirty conditions. Refer to the Engine Owner's Manual for cleaning or replacement instructions.

Spark Plug – Inspect and clean or replace the spark plug after every 100 operating hours or annually. Refer to the Engine Owner's Manual for cleaning or replacement instructions.

Spark Arrester Screen – If the engine is equipped with a spark arrester screen, remove and clean it according to the time intervals and instructions in the Engine Owner's Manual.

Engine Cleaning – The engine must be kept clean to assure smooth operation and to prevent damage from overheating. Refer to the Engine Owner's Manual for specific cleaning instructions.

Carburetor/Governor Control Adjustments – The carburetor was adjusted at the factory for best operating speed. Refer to the Engine Owner's Manual for any adjustment information.

The governor controls the maximum safe operating speed and protects the engine and other moving parts from damage caused by overspeeding. Do not tamper with the governor settings. Seek authorized service if you think an adjustment is required.

Throttle Control Adjustment – If the engine does not shut off when the throttle lever is moved to the stop position, or if the engine does not respond to various throttle settings, refer to the Engine Owner's Manual for service information.

OFF-SEASON STORAGE

When storing the machine for extended periods, follow these procedures to ensure that the unit will be in good condition for future use.

- Store machine on a level surface.
- Thoroughly inspect the machine for any loose, broken or missing parts. Repair or replace parts as necessary.
- Protect the engine and perform the recommended engine maintenance by following the engine storage instructions found in the Engine Owner's Manual. Be sure to protect the fuel lines, carburetor and fuel tank from gum deposits by removing fuel or by treating fuel with a fuel stabilizer (follow the engine manufacturer's recommendations).

⚠ WARNING

- **Never perform maintenance when engine is running or spark plug wire is connected, except when instructed to do so.**
 - **Never store mower with fuel in fuel tank inside a building where fumes can reach an open flame or spark, or where ignition sources are present such as hot water and space heaters, furnaces, clothes dryers, stoves, electric motors, etc. Make sure engine is cool before storing.**
 - **Drain gasoline outdoors into an approved container. Do not smoke and keep fuel away from open flame.**
- Failure to follow these instructions will result in serious personal injury or property damage.**

- Clean any dirt, grass or chaff from the air cooling system intake area and other parts of the engine.
- Disconnect spark plug wire from spark plug. Prevent wire from touching spark plug by placing wire away from spark plug.

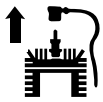
WARNING

Before inspecting, cleaning or servicing the machine, shut off engine, wait for all moving parts to come to a complete stop, disconnect spark plug wire and move wire away from spark plug. Remove ignition key on electric start models.

Failure to follow these instructions can result in serious personal injury or property damage.

CHANGING TRIMMER LINES

The trimmer lines will wear with use and eventually require replacement. Also, you may wish to switch between the thinner and thicker gauge lines to handle different mowing conditions.

Replace the trimmer lines when they wear to the point that trimming and mowing projects take too long and requires too much maneuvering of the machine. A good rule of thumb is to change the lines when they reach half of their original length.

Use the extra-heavy duty gauge (.155" diameter) line when cutting thick, tough growth. The thinner gauge (.130" diameter) line is for use in less demanding conditions, and is also recommended for use near trees or ornamental plantings to help prevent girdling (cutting of bark).

To Change Trimmer Lines:

1. Stop engine, allow all moving parts to stop and then disconnect the spark plug wire and move it away from the spark plug. Remove the ignition key on electric start models. DO NOT tip the machine. DO NOT touch the metal wear cup on the bottom of the spindle head. This surface may be hot.

NOTE: The two line holders on the trimmer head are permanently secured by a screw and nut. Do not attempt to remove the line holders as it is not necessary to remove them in order to change the trimmer lines.

2. The trimmer lines can be changed when the trimmer head is in contact with the ground. If necessary, you may tip the unit back slightly for a better view. However, do not tip the unit all the way back or motor oil may flow to the exhaust area and the engine may smoke for several seconds when started.

3. Three different line installation patterns are available, as shown in Figures 5-11, 5-12 and 5-13.

4. Simply fee the line through the loops of the line holder as shown. An equal

amount of line should project out from each side of the line holder, creating an overall 22" wide cutting swath. The two lines can be offset to increase the cutting swath up to 25" wide. DO NOT offset the lines so that the overall cutting swath is greater than 25". See Warning statement at right.

IMPORTANT: Whether replacing one or both lines, they must both be .130" or .155" in diameter.

5. Repeat steps 2 through 4 to replace the second trimmer line.

WARNING

Offsetting the trimmer lines causes the lines to rotate faster than when they project an equal length on each side. This increases the chance of loose materials being dislodged and propelled at high speeds.

Failure of the operator to wear safety goggles and appropriate clothing and to keep bystanders away can result in severe personal injury or property damage.

Figure 5-11: Use this single line, easy-loop pattern for all but the more difficult cutting conditions.

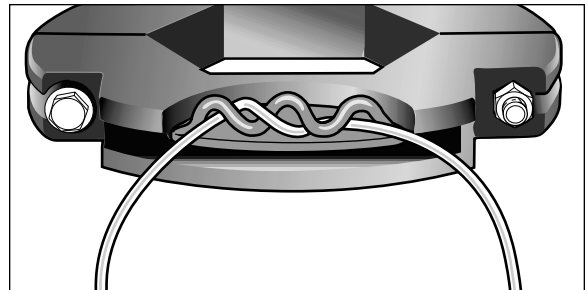

Figure 5-12: If lines tend to loosen (especially in more difficult cutting conditions), add a single reverse loop and then readjust line so that ends are even. This pattern results in a slightly narrower cutting swath.

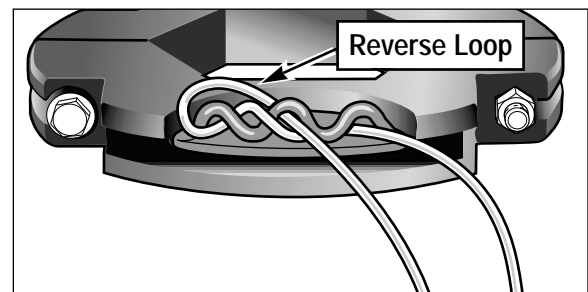
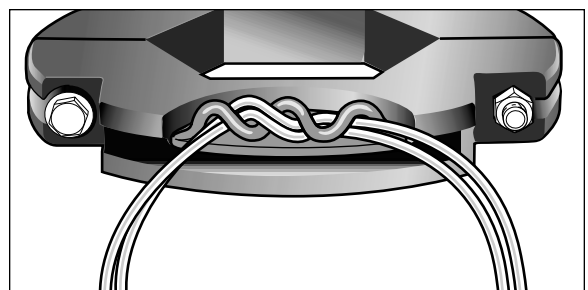
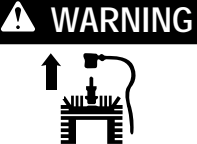

Figure 5-13: For more difficult cutting conditions, use two of the thicker (.155" diameter) lines in each line holder. Follow the pattern shown in Figure 5-11.



 WARNING	<p>Before inspecting, cleaning or servicing the machine, shut off engine, wait for all moving parts to come to a complete stop, disconnect spark plug wire and move wire away from spark plug. Remove ignition key on electric start models.</p> <p>Failure to follow these instructions can result in serious personal injury or property damage.</p>
--	--

TROUBLESHOOTING

Before performing any of the corrections in this Troubleshooting Chart, refer to the appropriate information contained in this Manual or the Engine Owner's Manual for the correct safety precautions and servicing procedures. Contact your local authorized Engine Service Dealer for engine service. Contact your local authorized dealer for service problems with the machine.

PROBLEM	POSSIBLE CAUSE	CORRECTION
Engine does not start.	<ol style="list-style-type: none"> 1. Spark plug wire disconnected. 2. Defective or incorrectly gapped spark plug. 3. Fuel tank empty. 4. Dirty carburetor or fuel line. 5. Dirty air cleaner. 6. Carburetor out of adjustment. 7. Engine flooded. 8. Engine Throttle Lever in incorrect position. 9. Stale gasoline. 10. Defective Engine Throttle Lever. 11. Dirt or water in fuel tank. 	<ol style="list-style-type: none"> 1. Connect wire. 2. Inspect/replace spark plug. 3. Add fuel. 4. See Engine Service Dealer. 5. Clean or replace. 6. See Engine Service Dealer. 7. Wait several minutes before starting. 8. Move Throttle Lever to FAST position. 9. Drain old fuel and add fresh fuel. 10. See Engine Service Dealer. 11. See Engine Service Dealer.
Engine runs poorly.	<ol style="list-style-type: none"> 1. Bad spark plug. 2. Dirty air filter. 3. Carburetor out of adjustment. 4. Stale fuel. 5. Dirt or water in fuel tank. 6. Engine cooling system clogged. 	<ol style="list-style-type: none"> 1. Inspect/replace spark plug. 2. Clean or replace. 3. See Engine Service Dealer. 4. Drain and replace fuel mixture. 5. See Engine Service Dealer. 6. Clean fins.
Engine overheats.	<ol style="list-style-type: none"> 1. Engine cooling system clogged. 2. Carburetor out of adjustment. 	<ol style="list-style-type: none"> 1. Clean air cooling areas and behind debris shield. 2. See Engine Service Dealer.
Engine does not shut off.	<ol style="list-style-type: none"> 1. Throttle control misadjusted. 	<ol style="list-style-type: none"> 1. See Engine Service Dealer.
Poor mowing performance.	<ol style="list-style-type: none"> 1. Line length is too short or too long. 2. Cutting height is too high or low for height of grass being cut. 3. Engine not set at FAST speed. 	<ol style="list-style-type: none"> 1. Adjust line length to 18" long. When less than 1/2 this length, replace the line. 2. Adjust cutting height to approximately 1/3 of the length of the grass. 3. Move Engine Throttle Lever to FAST (Rabbit).
Trimmer/Mower vibrates.	<ol style="list-style-type: none"> 1. Trimming head mounting nut loose. 2. Line lengths are substantially different. 3. Loose nuts or bolts. 4. Broken spindle head or trimmer head. 	<ol style="list-style-type: none"> 1. Tighten nut. 2. Adjust lines to approximately equal lengths. 3. Check all bolts and nuts, including engine bolts. 4. Replace broken part.
Trimmer head does not retain line.	<ol style="list-style-type: none"> 1. Incorrect line installation. 	<ol style="list-style-type: none"> 1. See <i>Changing Trimmer Lines</i> in Section 5.
Trimmer Head does not retain height setting.	<ol style="list-style-type: none"> 1. Head bolts may be loose. 2. Head is worn. 3. Foam inserts worn. 	<ol style="list-style-type: none"> 1. Tighten head bolts to 75 in/lbs. 2. Replace head assembly. 3. Replace foam inserts

DRAWING NO. 1

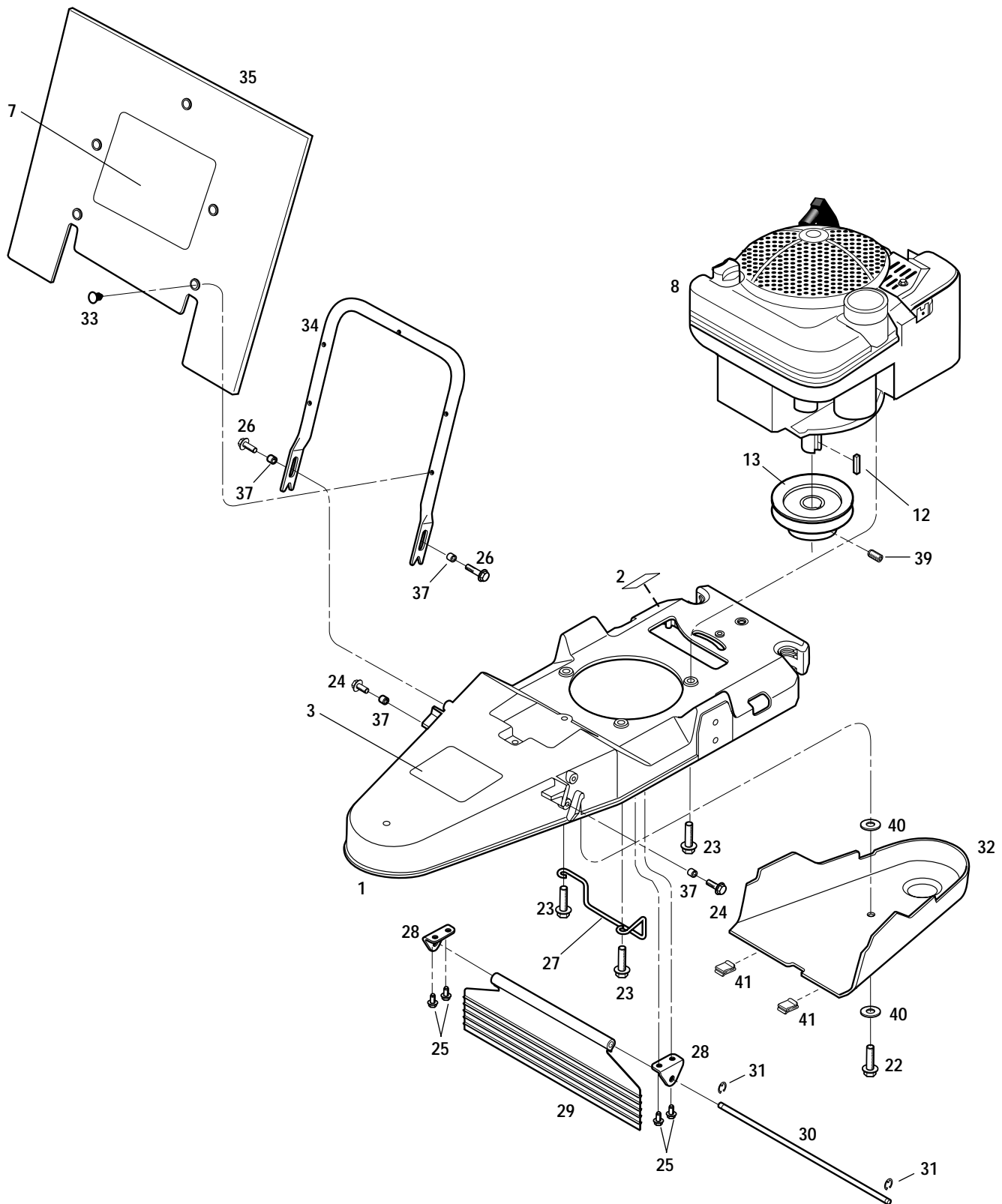

Model 52065

Ref. #	Part #	Description	Qty.	Ref. #	Part #	Description	Qty.
1	1916993	Deck (Incl. Refs. 2 and 3)	1	30	1915212	Deflector Flap Rod	1
2	1904511	Decal-Hot Surface.....	1	31	1185304	E-Ring, 5/16"	2
3	1918115	Decal-Warning/Thrown Objects	1	32	1915205	Belt Cover	1
7	1918082	Decal-Logo	1	33	1918415	Push-In Fastener	5
8	*	Engine.....	1	34	1915967	Debris Guard Support.....	1
12	9301	Key, 3/16" x 1" Sq.	1	35	1917765	Debris Guard	1
13	1915240	Pulley, 4" OD.....	1	37	1915320	Spacer	4
22	90063	Hex Hd. Flange Screw, 5/16-18 x 1.....	1	39	9677	Set Screw	1
23	1768194	Hex Hd. Flange Screw, 3/8-16 x 1-1/2	3	40	94018	Washer	2
24	1754128	Hex Hd. Flange Screw, 1/4-20 x 3/4	2	41	9218	Clip	2
25	1909301	Hex Hd. Flange Screw, 1/4-20 x 5/8	4				
26	1763187	Hex Hd. Flange Screw, 1/4-20 x 1.....	2				
27	1910865	Belt Guide	1				
28	1915219001	Flap Bracket	2				
29	1917154	Deflector Flap.....	1				

* Order parts from your local authorized engine dealer. Refer to engine for model/type number.

N/I Not included with unit, order separately

DRAWING NO. 2

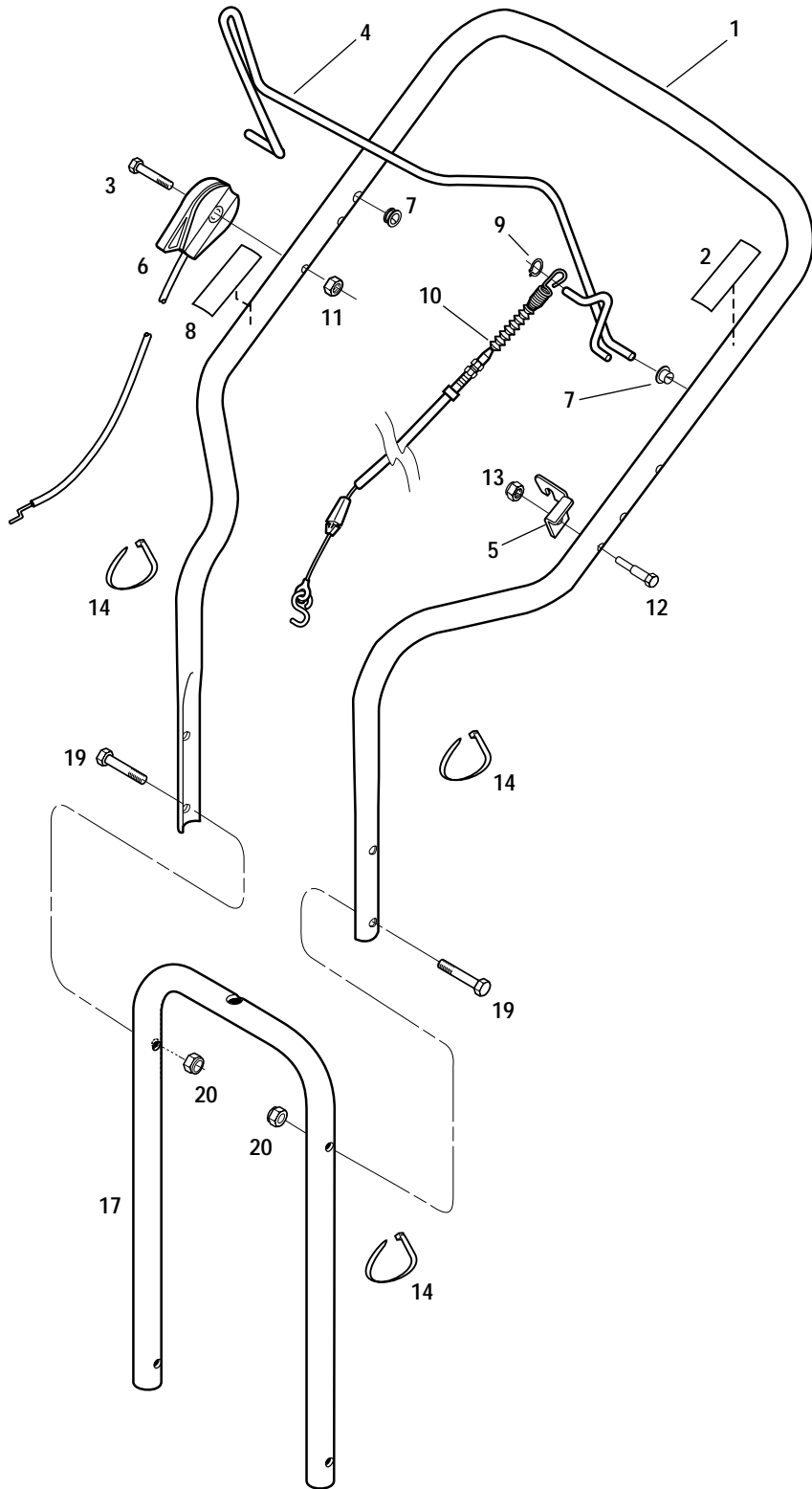

PARTS LIST – DRAWING NO. 2

Ref. #	Part #	Description	Qty.	Ref. #	Part #	Description	Qty.
1	1915963	Upper Handlebar (Incl. Refs. 2 & 8)	1	10	1910852	Trimmer Head Control Cable	1
2	1915889	Decal-Bail Operation	1	11	1110106	Hex Lock Nut, 1/4-20	1
3	1100807	Hex Hd. Screw, 1/4-20 x 2	1	12	1983658	Hex Hd. Screw, 1/4-20 x 1-1/8	1
4	1917175	Trimmer Head Control Bail	1	13	1185814	Hex Flange Lock Nut, 1/4-20	1
5	1749977001	Cable Bracket	1	14	1763682	Cable Tie	3
6	1918081	Throttle Control & Cable	1	17	1910809001	Lower Handlebar	1
7	1908677	Nyliner Bushing	2	19	1100799	Hex Hd. Screw, 5/16-18 x 1-1/2, Gr. 5 ...	2
8	1918304	Decal-Throttle Settings	1	20	1732499	Lock Nut, 5/16-18	2
9	1908679	Push Cap, .312 I.D.	1				

PARTS LIST – DRAWING NO. 3

Ref. #	Part #	Description	Qty.
1	1910850001	Spindle Mounting Plate	1
2	1769048	Spindle Assembly	1
3	1915477	Spindle Shaft Assembly (Incl. Ref. 25) ...	1
4	1910860001	Belt Guide	1
5	1910856	Spindle Spacer	1
6	1910842	Spindle Pulley	1
7	1904308	Hex Flange Nut, 1/2-13	1
8	1915555	V-Belt	1
9	1904479	Idler Arm/Brake Shoe Assembly	1
10	1910859	Socket Hd Capscrew, 10-24 x 3/4	1
11	1910847	Brake Shoe	1
12	1983039	Hex Lock Nut, 10-24	1
13	1727978	V-Groove Idler Pulley	1
14	1186393	Hex Flange Nut, 3/8-16	2
15	1910855	Flat Idler Pulley	1
16	1915261	Washer, .88 x .382 x .275	1
17	1910854	Idler Arm Spacer	1
18	1910857	Button Head Screw, 3/8-16 x 1-1/2	1
19	1910852	Control Cable (also Ref. 13, Pg. 4)	1
20	1910849	Idler Tension Spring	1
21	1910858	Hex Flange Screw, 3/8 x 16 x 2-1/4	1
22	1909304	Hex Flange Screw, 5/16-18 x 3/4	4
23	90063	Hex Flange Screw, 5/16-18 x 1	5
24	9953	Hardened Shim, 3/4 ID x 1.022 OD x .060 thick	1
25	9928	Belleville Washer, 5/8	1

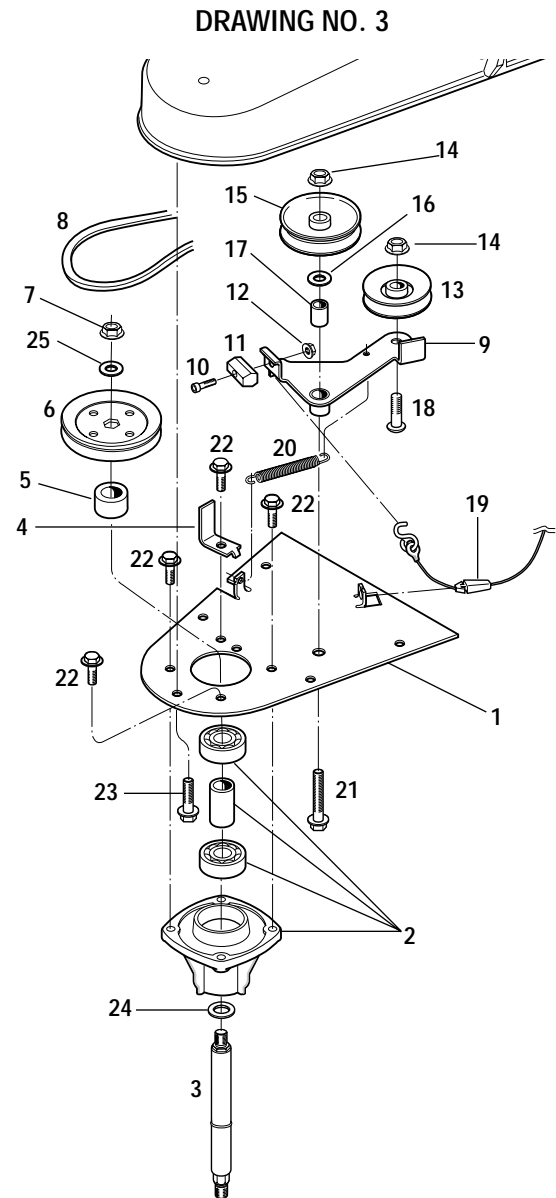

DRAWING NO. 4

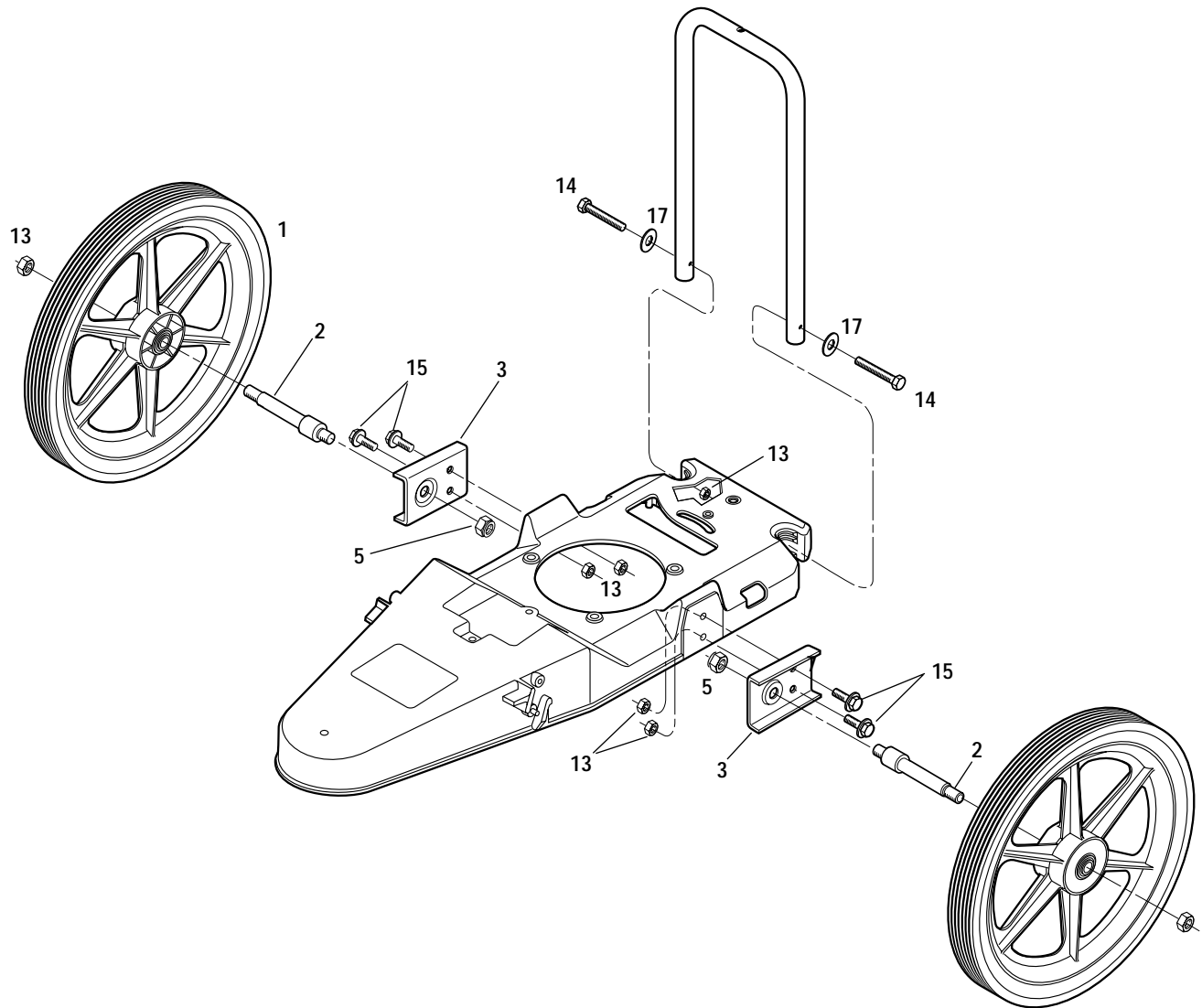

Ref. #	Part #	Description	Qty.	Ref. #	Part #	Description	Qty.
1	1917778	Wheel - 6 spoke	2	14	1111606	Hex Head Bolt, 5/16-18 x 2	2
2	1915823	Wheel Stud.....	2	15	1186331	Hex Flange Screw, 5/16-18 x 1.....	4
3	1915824	Wheel Mounting Bracket	2	17	9901	Washer, 5/16 ID	2
5	1733398	Top Lock Nut, 3/8-16	2				
13	1744708	Hex Lock Nut, 5/16-18	8				

Model 52065

DRAWING NO. 5

Ref. #	Part #	Description	Qty.
1	1910863	Shoulder Washer.....	1
2	1910861	Spindle Head.....	1
3	1918879	Trimmer Head.....	1
4	--	Trimmer String (see Refs. 1 and 2 below).....	--
5	1910862	Hex Spline Washer.....	1
6	1915220001	Wear Cup.....	1
7	1915239	Washer.....	1
8	1904308	Hex Flange Nut, 1/2-13.....	1
9	1918332	Rubber Shim Kit (2 shims). Affixed to two inner walls of trimmer head.....	1

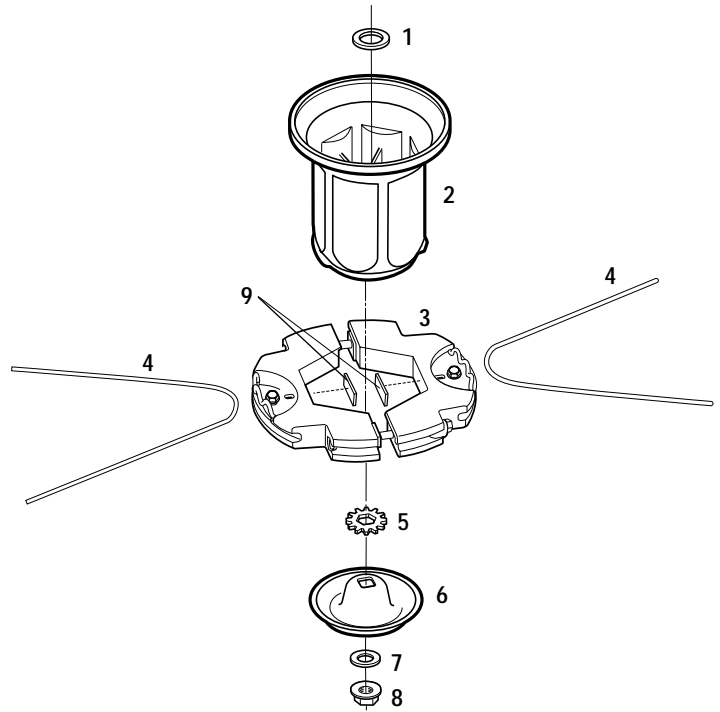

ACCESSORIES AND KITS

Ref. #	Part #	Description	Qty.
1	1904476	Trimmer String Kit, .155" (includes 24 pieces).....	N/I
2	1904477	Trimmer String Kit, .130" (includes 24 pieces).....	N/I

N/I Not included with unit, order separately

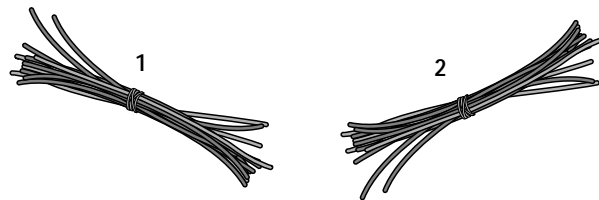

CUSTOMER SERVICE INFORMATION

Owner Registration Card

Please fill out and mail the enclosed owner registration card. The purpose of this card is to register each unit at the factory so that we can provide you with warranty benefits and informational bulletins.

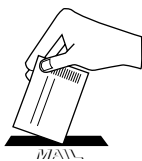

Warranty Service

The warranty statement is included in the unit's literature package.

Model/Serial Numbers

A Model/Serial Numbers decal is located on the side of the deck. For ready reference, record these numbers in the spaces below.

Date of Purchase: _____

Model Number: _____

Serial Number: _____

Authorized Dealer Information

If you purchased your unit from an authorized dealer, record the dealer's address and phone number below for ready reference:

Dealer Name: _____

Address: _____

Phone: _____

IMPORTANT:

Left and right sides of the unit are determined by standing behind the unit, in the operator's position, and facing in the direction of forward travel.

NOTICE:

We reserve the right to change specifications, add improvements or discontinue the manufacture of any of our equipment without notice or obligation to purchasers of our equipment.

Customer Service and Technical Service

If you have questions or problems with the unit, contact your local dealer or the factory. (When calling or writing, provide the Model/Serial Numbers of the unit.)



Replacement Parts

Factory specified replacement parts are available from your authorized dealer or directly from the factory. When ordering parts, be sure to provide the following:

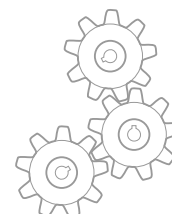

- Model/Serial Numbers of the unit.
- Part number of the part needed.
- Part Description.
- Quantity needed.

NOTE: All replacement parts must conform to our rigid quality specifications. Although some replacement parts we provide may vary slightly in shape, color or texture from the original parts, any variations will not affect the fit or performance of these parts on your unit.

Engine Service and Repair

For engine service or repair, contact your nearest authorized engine dealer (look in the Yellow Pages under "Engines-Gasoline"). The engine is warranted by the engine manufacturer. Any unauthorized work performed on the engine during the warranty period may void this warranty. For complete details on the engine warranty, refer to the engine owner manual.

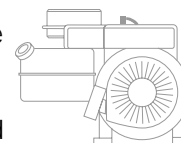

WARNING

We urge using only genuine replacement parts, which meet all the latest requirements. Replacement parts manufactured by others could present safety hazards, even though they may fit on the unit.

For customer assistance, contact your nearest authorized dealer or:

GARDEN WAY INCORPORATED • 1 Garden Way • Troy, New York 12180
Customer Service: 1-800-437-8686 • Technical Service: 1-800-520-5520 • Parts Service: 1-800-648-6776
• FAX: (518) 233-4622 • WEB SITE: www.troybilt.com

Outside the United States and Canada:

Customer Service: (518) 233-4807 • Technical Service: (518) 233-4808 • Parts Service: (518) 233-4806 • FAX (518) 233-4622

Free Manuals Download Website

<http://myh66.com>

<http://usermanuals.us>

<http://www.somanuals.com>

<http://www.4manuals.cc>

<http://www.manual-lib.com>

<http://www.404manual.com>

<http://www.luxmanual.com>

<http://aubethermostatmanual.com>

Golf course search by state

<http://golfingnear.com>

Email search by domain

<http://emailbydomain.com>

Auto manuals search

<http://auto.somanuals.com>

TV manuals search

<http://tv.somanuals.com>