

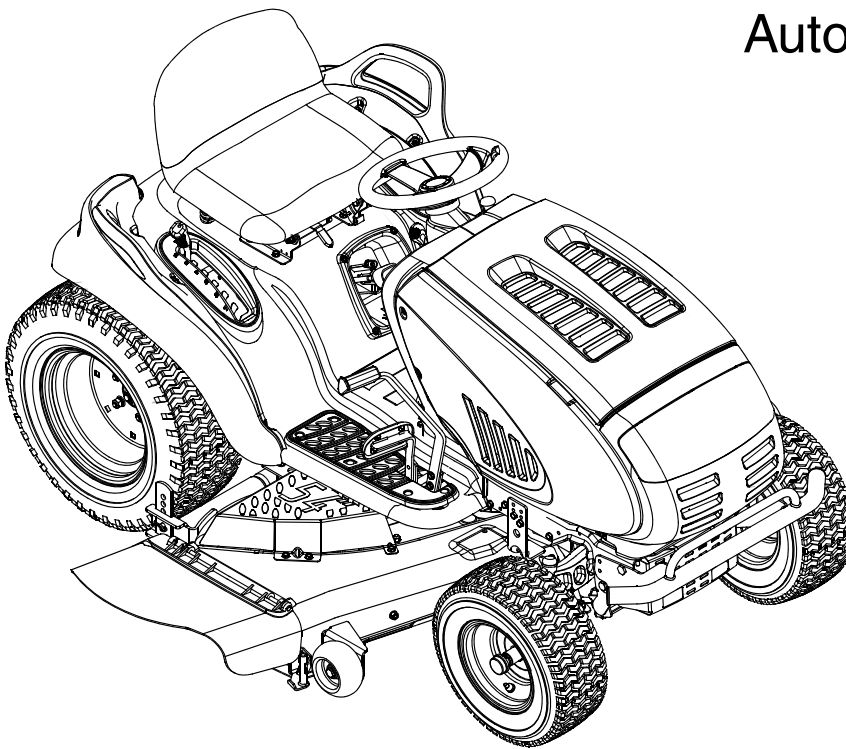

Operator's Manual

Automatic Garden Tractor



**IMPORTANT: READ SAFETY
RULES AND INSTRUCTIONS
CAREFULLY.**

P. O. BOX 1386, KITCHENER, ONTARIO CANADA N2G 4J1

PRINTED IN UNITED-STATES

772C0748
(01/05)

TABLE OF CONTENTS

Content	Page	Content	Page
Finding Your Model Number	2	Adjustments	18
Calling Customer Support	2	Maintenance	20
Important Safe Operation Practices	3	Lubrication	21
Safety Labels Found On Your Unit	6	Service	22
Attachments and Accessories	6	Off-Season Storage	26
Slope Gauge	7	Troubleshooting	27
Tractor Set-Up	8	Parts List/Pièces détachées	28
Controls	11	Warranty	45
Operation	14		

FINDING MODEL NUMBER

This Operator's Manual is an important part of your new lawn tractor. It will help you assemble, prepare and maintain the unit for best performance. Please read and understand what it says.



Before you start assembling your new equipment, please locate the model plate on the equipment and copy the information from it in the space provided below. This information will be necessary to use the manufacturer's web site and/or help from the Customer Support Department or an authorized service dealer.

- You can locate the model number by looking beneath the seat. A sample model plate is explained below.

Model Number Numéro de modèle	Serial Number Numéro de série
XXX-XXXXXX	XXXXXXXXXXXX

TROY-BILT TROYBILT - CANADA
KITCHENER, ON N2G 4J1

Copy the model number here: _____

Copy the serial number here: _____

ENGINE INFORMATION

The engine manufacturer is responsible for all engine-related issues with regards to performance, power-rating, specifications, warranty and service. Please refer to the engine manufacturer's Owner's/Operator's Manual packed separately with your unit for more information.

CALLING CUSTOMER SUPPORT

Please do NOT return the unit to the retailer from which it was purchased, without first contacting Customer Support.



If you have difficulty assembling this product or have any questions regarding the controls, operation or maintenance of this unit, please call a Customer Support Representative 1-800-668-1238

Please have your unit's model number and serial number ready when you call. See previous section to locate this information. You will be asked to enter the serial number in order to process your call.

HOW TO OBTAIN SERVICE

Warranty service is available, WITH PROOF OF PURCHASE, through your local authorized service dealer. To locate the dealer in your area;

Contact P.O. Box 1386, Kitchener, ON N2G 4J1, or call 1-800-668-1238 or log on to our Web site at www.mtdcanada.com.

SECTION 1: IMPORTANT SAFE OPERATION PRACTICES



WARNING: This symbol points out important safety instructions which, if not followed, could endanger the personal safety and/or property of yourself and others. Read and follow all instructions in this manual before attempting to operate this machine. Failure to comply with these instructions may result in personal injury. When you see this symbol—heed its warning.



DANGER: This machine was built to be operated according to the rules for safe operation in this manual. As with any type of power equipment, carelessness or error on the part of the operator can result in serious injury. This machine is capable of amputating hands and feet and throwing objects. Failure to observe the following safety instructions could result in serious injury or death.

GENERAL OPERATION

1. Read, understand, and follow all instructions on the machine and in the manual(s) before attempting to assemble and operate. Keep this manual in a safe place for future and regular reference and for ordering replacement parts.
2. Be familiar with all controls and their proper operation. Know how to stop the machine and disengage them quickly.
3. Never allow children under 14 years old to operate this machine. Children 14 years old and over should read and understand the operation instructions and safety rules in this manual and should be trained and supervised by a parent.
4. Never allow adults to operate this machine without proper instruction.
5. To help avoid blade contact or a thrown object injury, keep bystanders, helpers, children and pets at least 75 feet from the machine while it is in operation. Stop machine if anyone enters the area.
6. Thoroughly inspect the area where the equipment is to be used. Remove all stones, sticks, wire, bones, toys, and other foreign objects which could be picked up and thrown by the blade(s). Thrown objects can cause serious personal injury.
7. Plan your mowing pattern to avoid discharge of material toward roads, sidewalks, bystanders and the like. Also, avoid discharging material against a wall or obstruction which may cause discharged material to ricochet back toward the operator.
8. Always wear safety glasses or safety goggles during operation and while performing an adjustment or repair to protect your eyes. Thrown objects which ricochet can cause serious injury to the eyes.
9. Wear sturdy, rough-soled work shoes and close-fitting slacks and shirts. Loose fitting clothes and jewelry can be caught in movable parts. Never operate this machine in bare feet or sandals.
10. Be aware of the mower and attachment discharge direction and do not point it at anyone. Do not operate the mower without the discharge cover or entire grass catcher in its proper place.
11. Do not put hands or feet near rotating parts or under the cutting deck. Contact with the blade(s) can amputate hands and feet.
12. A missing or damaged discharge cover can cause blade contact or thrown object injuries.
13. Stop the blade(s) when crossing gravel drives, walks, or roads and while not cutting grass.
14. Watch for traffic when operating near or crossing roadways. This machine is not intended for use on any public roadway.
15. Do not operate the machine while under the influence of alcohol or drugs.
16. Mow only in daylight or good artificial light.
17. Never carry passengers.
18. Disengage blade(s) before shifting into reverse. Back up slowly. Always look down and behind before and while backing to avoid a back-over accident.
19. Slow down before turning. Operate the machine smoothly. Avoid erratic operation and excessive speed.
20. Disengage blade(s), set parking brake, stop engine and wait until the blade(s) come to a complete stop before removing grass catcher, emptying grass, unclogging chute, removing any grass or debris, or making any adjustments.
21. Never leave a running machine unattended. Always turn off blade(s), place transmission in neutral, set parking brake, stop engine and remove key before dismounting.
22. Use extra care when loading or unloading the machine into a trailer or truck. This unit should not be driven up or down ramp(s), because the unit could tip over, causing serious personal injury. The unit must be pushed manually on ramp(s) to load or unload properly.
23. Muffler and engine become hot and can cause a burn. Do not touch.
24. Check overhead clearances carefully before driving under low hanging tree branches, wires, door openings etc., where the operator may be struck or pulled from the unit, which could result in serious injury.

25. Disengage all attachment clutches, depress the brake pedal completely and shift into neutral before attempting to start engine.
26. Your machine is designed to cut normal residential grass of a height no more than 10". Do not attempt to mow through unusually tall, dry grass (e.g., pasture) or piles of dry leaves. Dry grass or leaves may contact the engine exhaust and/or build up on the mower deck presenting a potential fire hazard.
27. Use only accessories and attachments approved for this machine by the machine manufacturer. Read, understand and follow all instructions provided with the approved accessory or attachment.
28. Data indicates that operators, age 60 years and above, are involved in a large percentage of riding mower-related injuries. These operators should evaluate their ability to operate the riding mower safely enough to protect themselves and others from serious injury.
29. If situations occur which are not covered in this manual, use care and good judgment. Contact your authorized dealer for assistance.

SLOPE OPERATION

Slopes are a major factor related to loss of control and tip-over accidents which can result in severe injury or death. All slopes require extra caution. If you cannot back up the slope or if you feel uneasy on it, do not mow it.

For your safety, use the slope gauge included as part of this manual to measure slopes before operating this unit on a sloped or hilly area. If the slope is greater than 15 degrees as shown on the slope gauge, do not operate this unit on that area or serious injury could result.

DO:

1. Mow up and down slopes, not across. Exercise extreme caution when changing direction on slopes.
2. Watch for holes, ruts, bumps, rocks, or other hidden objects. Uneven terrain could overturn the machine. Tall grass can hide obstacles.
3. Use slow speed. Choose a low enough speed setting so that you will not have to stop or shift while on the slope. Tires may lose traction on slopes even though the brakes are functioning properly. Always keep machine in gear when going down slopes to take advantage of engine braking action.
4. Follow the manufacturer's recommendations for wheel weights or counterweights to improve stability.
5. Use extra care with grass catchers or other attachments. These can change the stability of the machine.

6. Keep all movement on the slopes slow and gradual. Do not make sudden changes in speed or direction. Rapid engagement or braking could cause the front of the machine to lift and rapidly flip over backwards which could cause serious injury.
7. Avoid starting or stopping on a slope. If tires lose traction, disengage the blade(s) and proceed slowly straight down the slope.

DO NOT:

1. Do not turn on slopes unless necessary; then, turn slowly and gradually downhill, if possible.
2. Do not mow near drop-offs, ditches or embankments. The mower could suddenly turn over if a wheel is over the edge of a cliff, ditch, or if an edge caves in.
3. Do not try to stabilize the machine by putting your foot on the ground.
4. Do not use a grass catcher on steep slopes.
5. Do not mow on wet grass. Reduced traction could cause sliding.
6. Do not shift to neutral and coast downhill. Over-speeding may cause the operator to lose control of the machine resulting in serious injury or death.
7. Do not tow heavy pull behind attachments (e.g. loaded dump cart, lawn roller, etc.) on slopes greater than 5 degrees. When going down hill, the extra weight tends to push the tractor and may cause you to lose control. (e.g. tractor may speed up, braking and steering ability are reduced, attachment may jack-knife and cause tractor to overturn).

CHILDREN

1. Tragic accidents can occur if the operator is not alert to the presence of children. Children are often attracted to the machine and the mowing activity. They do not understand the dangers. Never assume that children will remain where you last saw them.
 - a. Keep children out of the mowing area and in watchful care of a responsible adult other than the operator.
 - b. Be alert and turn machine off if a child enters the area.
 - c. Before and while backing, look behind and down for small children.
 - d. Never carry children, even with the blade(s) shut off. They may fall off and be seriously injured or interfere with safe machine operation.
 - e. Use extreme care when approaching blind corners, doorways, shrubs, trees or other objects that may block your vision of a child who may run into the machine.
 - f. **To avoid back-over accidents, always disengage the cutting blade(s) before**

shifting into reverse. The “Reverse Caution Mode” should not be used when children or others are around.

- g. Keep children away from hot or running engines. They can suffer burns from a hot muffler.
 - h. Remove key when machine is unattended to prevent unauthorized operation.
2. Never allow children under 14 years old to operate the machine. Children 14 years old and over should read and understand the operation instructions and safety rules in this manual and should be trained and supervised by a parent.

TOWING

1. Tow only with a machine that has a hitch designed for towing. Do not attach towed equipment except at the hitch point.
2. Follow the manufacturers recommendation for weight limits for towed equipment and towing on slopes.
3. Never allow children or others in or on towed equipment.
4. On slopes, the weight of the towed equipment may cause loss of traction and loss of control.
5. Travel slowly and allow extra distance to stop.
6. Do not shift to neutral and coast downhill.

SERVICE

SAFE HANDLING OF GASOLINE:

1. **To avoid personal injury or property damage** use extreme care in handling gasoline. **Gasoline is** extremely flammable and the vapors are explosive. Serious personal injury can occur when gasoline is spilled on yourself or your clothes which can ignite. Wash your skin and change clothes immediately.
 - a. Use only an approved gasoline container.
 - b. Never fill containers inside a vehicle or on a truck or trailer bed with a plastic liner. Always place containers on the ground away from your vehicle before filling.
 - c. When practical, remove gas-powered equipment from the truck or trailer and refuel it on the ground. If this is not possible, then refuel such equipment on a trailer with a portable container, rather than from a gasoline dispenser nozzle.
 - d. Keep the nozzle in contact with the rim of the fuel tank or container opening at all times until fueling is complete. Do not use a nozzle lock-open device.
 - e. Extinguish all cigarettes, cigars, pipes and other sources of ignition.
 - f. Never fuel machine indoors.
 - g. Never remove gas cap or add fuel while the engine is hot or running. Allow engine to cool at least two minutes before refueling.

- h. Never over fill fuel tank. Fill tank to no more than ½ inch below bottom of filler neck to allow space for fuel expansion.
- i. Replace gasoline cap and tighten securely.
- j. If gasoline is spilled, wipe it off the engine and equipment. Move unit to another area. Wait 5 minutes before starting the engine.
- k. To reduce fire hazards, keep machine free of grass, leaves, or other debris build-up. Clean up oil or fuel spillage and remove any fuel soaked debris.
- l. Never store the machine or fuel container inside where there is an open flame, spark or pilot light as on a water heater, space heater, furnace, clothes dryer or other gas appliances.
- m. Allow a machine to cool at least 5 minutes before storing.

GENERAL SERVICE:

1. Never run an engine indoors or in a poorly ventilated area. Engine exhaust contains carbon monoxide, an odorless, and deadly gas.
2. Before cleaning, repairing, or inspecting, make certain the blade(s) and all moving parts have stopped. Disconnect the spark plug wire and ground against the engine to prevent unintended starting.
3. Periodically check to make sure the blades come to complete stop within approximately (5) five seconds after operating the blade disengagement control. If the blades do not stop within the this time frame, your unit should be serviced professionally by an authorized dealer.
4. Check brake operation frequently as it is subjected to wear during normal operation. Adjust and service as required.
5. Check the blade(s) and engine mounting bolts at frequent intervals for proper tightness. Also, visually inspect blade(s) for damage (e.g., excessive wear, bent, cracked).
Replace the blade(s) with the original equipment manufacturer’s (O.E.M.) blade(s) only, listed in this manual. “Use of parts which do not meet the original equipment specifications may lead to improper performance and compromise safety!”
6. Mower blades are sharp. Wrap the blade or wear gloves, and use extra caution when servicing them.
7. Keep all nuts, bolts, and screws tight to be sure the equipment is in safe working condition.
8. Never tamper with the safety interlock system or other safety devices. Check their proper operation regularly.
9. After striking a foreign object, stop the engine, disconnect the spark plug wire(s) and ground against the engine. Thoroughly inspect the machine for any damage. Repair the damage before starting and operating.

10. Never attempt to make adjustments or repairs to the machine while the engine is running.
11. Grass catcher components and the discharge cover are subject to wear and damage which could expose moving parts or allow objects to be thrown. For safety protection, frequently check components and replace immediately with original equipment manufacturer's (O.E.M.) parts only, listed in this manual. "Use of parts which do not meet the origi-

nal equipment specifications may lead to improper performance and compromise safety!"

12. Do not change the engine governor settings or over-speed the engine. The governor controls the maximum safe operating speed of the engine.
13. Maintain or replace safety and instruction labels, as necessary.
14. Observe proper disposal laws and regulations for gas, oil, etc. to protect the environment.



WARNING: YOUR RESPONSIBILITY Restrict the use of this power machine to persons who read, understand and follow the warnings and instructions in this manual and on the machine.

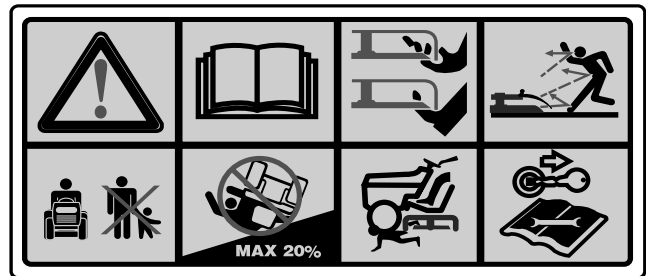
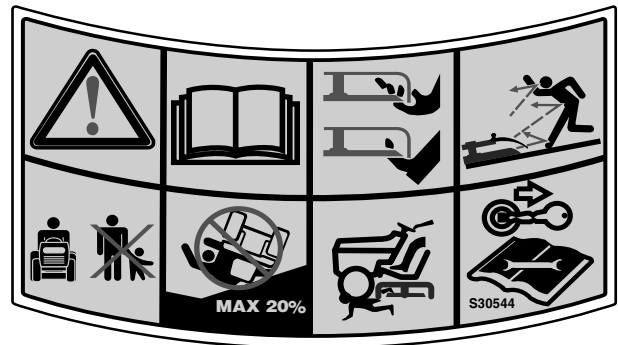
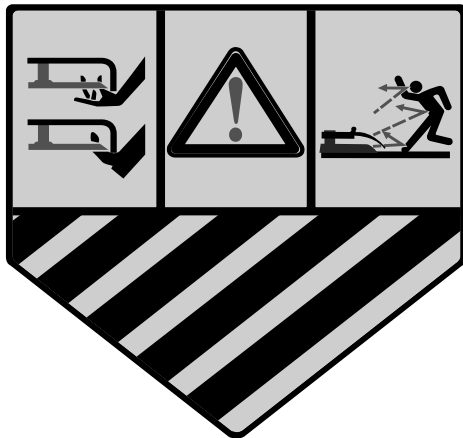

Safety Labels found on your unit

SECTION 2: ATTACHMENTS & ACCESSORIES

The following attachments and accessories are compatible for your Garden Tractor. See the retailer from which you purchased your tractor, an Authorized Service Dealer.

MODEL	DESCRIPTION
OEM-190-604	Yard-Mate™ Storage Container/Toolbox (mounts on rear of tractor)
OEM-190-607	Deluxe Tractor Sunshade
OEM-190-603	Bumper Kit
OEM-190-608	Sleeve Hitch, Manual Lift
OEM-190-842	Triple Bagger Grass Collector
OEM-190-822	46-inch Front Dozer Blade
OEM-190-823	42-inch Two-stage Snow Thrower
OEM-190-824	Sleeve Hitch with Electric Lift
OEM-190-825	30-inch Hydraulic Tiller†
OEM-190-841	Mulch Kit
490-900-0025	Deck Wash Kit

† 190-824 is required for use of this attachment. **190-608 cannot be used in its place.**

SECTION 3: SLOPE GAUGE

USE THIS PAGE AS A GUIDE TO DETERMINE SLOPES WHERE YOU MAY NOT OPERATE SAFELY.

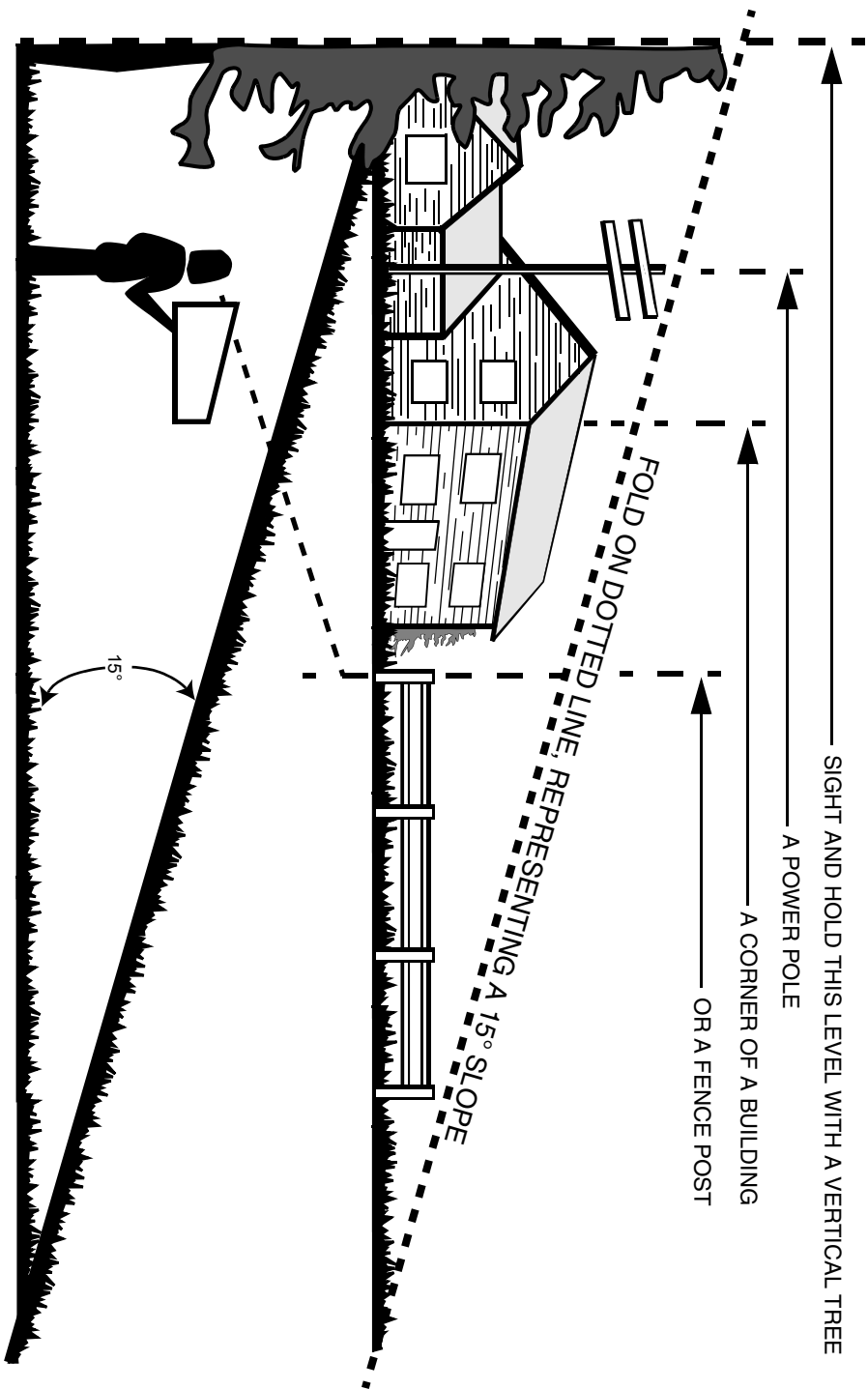

WARNING

Do not mow on inclines with a slope in excess of 15 degrees (a rise of approximately 2-1/2 feet every 10 feet). A riding mower could overturn and cause serious injury. If operating a walk-behind mower on such a slope, it is extremely difficult to maintain your footing and you could slip, resulting in serious injury. Operate RIDING mowers up and down slopes, never across the face of slopes.

SECTION 4: TRACTOR SET-UP

NOTE: Reference to *RIGHT* or *LEFT* side of the tractor in this manual is observed from operator's position.

ATTACHING THE BATTERY CABLES

NOTE: The battery cables may or may not be attached on your unit. If the cables are not attached, please follow the instructions below.

NOTE: The positive battery terminal is marked Pos. (+). The negative battery terminal is marked Neg. (-).

- The positive cable (heavy red wire) is secured to the positive battery terminal (+) with a hex bolt and hex nut at the factory. Make certain that the rubber boot covers the terminal to help protect it from corrosion.
- Remove the hex bolt and wing nut from the negative cable.
- Remove the black plastic cover, if present, from the negative battery terminal and attach the negative cable (heavy black wire) to the negative battery terminal (-) with the bolt and wing nut.
- Make certain the battery retainer rod is in position over the battery, securing it in place. See Figure 1.

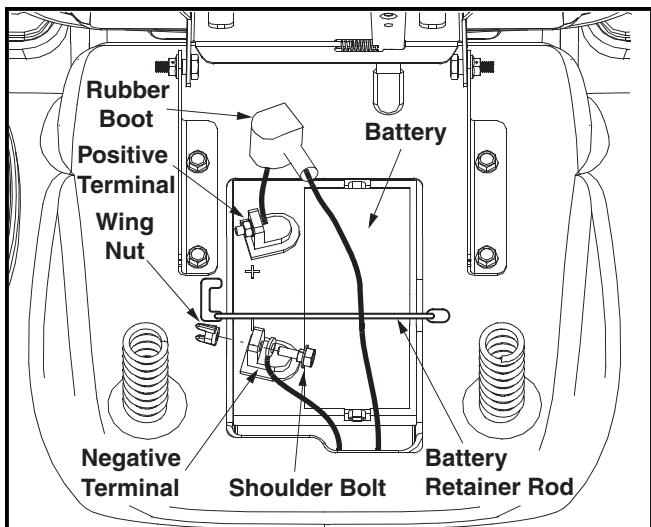

Figure 1

NOTE: If the battery is put into service after the date shown on top of battery, charge the battery as instructed on page 23 of this manual prior to operating the tractor.

ATTACHING THE STEERING WHEEL

In the event your tractor was crated with the steering wheel and the seat removed for shipping reasons, use the following instructions to properly assemble the parts.



WARNING: Do NOT operate the tractor without first attaching both the steering wheel AND the seat. Doing so could result in serious injury to the operator.

NOTE: There are two different styles of steering wheel cap. See Figure 2. **Styles vary by model.**

- Using your hands, place the tractor's front tires in position for straight-ahead travel.
- Remove the steering wheel cap from the center of the steering wheel. Be careful not to lose the hex screw and cupped washer found beneath it.
- Place the steering wheel (in position for straight-ahead travel) directly onto the steering shaft found in the center of the tractor's dash.
- Place the cupped washer (cupped side DOWN) over the steering shaft.
- Thread the hex screw into the steering shaft and tighten securely.
- Reinsert the steering wheel cap in the center of the steering wheel. Refer to Figure 2.

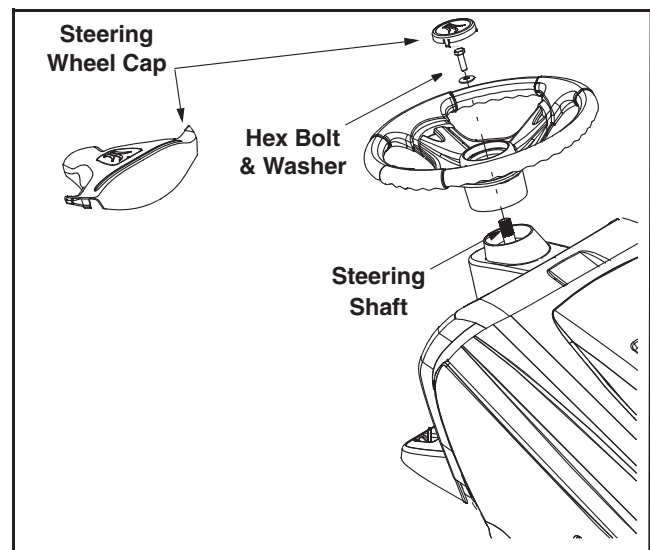

Figure 2

ATTACHING THE SEAT

NOTE: For shipping reasons, seats are either fastened to the tractor seat's pivot bracket with a plastic tie, or mounted backward to the pivot bracket. In either case, free the seat from its shipping position and remove the two hex screws (or knobs, on models so equipped) from the bottom of seat before proceeding with applicable instructions below.

Quick Adjustment Seat

NOTE: If your seat was shipped mounted backwards on the seat pivot bracket, pull out the tab found on the seat stop and hold it open while sliding the seat off the seat pivot bracket. See Figure 3 .

1. Line up the plastic seat spacers with the slots in seat pivot bracket.
2. Slide seat in until front seat spacer engages the seat stop. See Figure 3 .



WARNING: Before operating this machine, make sure the seat is engaged in the seat stop, stand behind the machine and pull back on seat until fully engaged into stop.

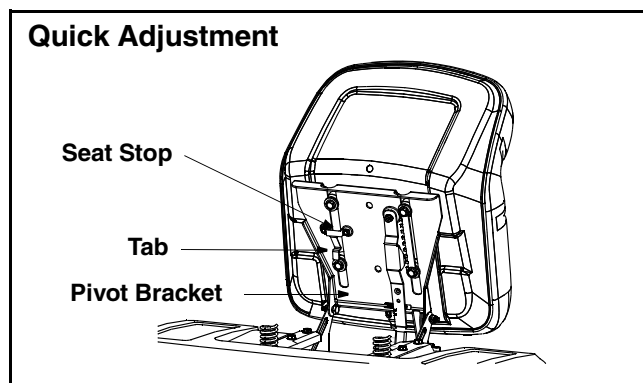

Figure 3

GAS AND OIL FILL-UP

The gasoline tank is located under the hood and has a capacity of either two or three gallons. Do not overfill.



WARNING: Use extreme care when handling gasoline. Gasoline is extremely flammable and the vapors are explosive. Never fuel machine indoors or while the engine is hot or running. Extinguish cigarettes, cigars, pipes, and other sources of ignition.

Service the engine with gasoline and oil as instructed in the separate engine manual packed with your tractor. Read instructions carefully.

IMPORTANT: Your tractor is shipped with oil; however, you **MUST** check the oil level before operating. Be careful not to overfill. Overfilling with oil may cause the engine to smoke. This will result in poor engine performance and could cause permanent engine damage.



WARNING: The mowing deck is capable of throwing objects. Failure to operate the riding mower without the discharge cover in the proper operating position could result in serious personal injury and/or property damage.

TIRE PRESSURE



WARNING: Maximum tire pressure under any circumstances is 30 p.s.i. Equal tire pressure should be maintained at all times.

The tires on your unit may be over-inflated for shipping purposes. Reduce the tire pressure before operating the tractor. Recommended operating tire pressure is approximately 10 p.s.i for the rear tires & 14 p.s.i. for the front tires. Check the sidewall of tire for maximum p.s.i.

ATTACHING THE CUTTING DECK 54” DECK



WARNING: Before attaching the cutting deck, engage the parking brake, turn the ignition key to the OFF position and remove the key from the switch to avoid accidental starting.

- Adjust the deck roller height so that the clevis pins are inserted in the second hole (from the top) of both the left-hand deck roller bracket and the right-hand deck roller bracket. See Figure 4 or refer to Deck Roller Height Adjustment .
- Raise the deck lift arms up and out of the way by placing the deck lift lever in the top notch on the right fender.
- Gently slide the cutting deck beneath the tractor from the right side.
- Move the cutting deck into position so that the hooks found on the front end of the deck fit snugly around the deck stabilizer rod as shown in Figure 4.

NOTE: The stabilizer rod may be secured to the tractor frame with a plastic cable tie for shipping reasons. If so, carefully cut the cable tie before mounting the front of the cutting deck.

- Lower the deck lift arms by placing the lift lever in the bottom notch on the right fender.
- Pull the deck support pin (on the left side of the deck) outward and align it with the hole on the rear of the left deck lift arm before releasing the pin to lock it in place as shown in Figure 4. Repeat on the right side.

INSTALLING THE PTO/DECK BELT

- Make certain that the PTO/Deck belt is routed around the spindle pulleys (found beneath the belt guards) and both idler pulleys as illustrated in inset in Figure 4 before proceeding.
- Insert a 3/8” drive ratchet wrench (set to “loosen”) into the hole on the idler bracket and pivot the wrench handle clockwise. This will relieve the tension on the deck idler.

IMPORTANT: Be certain that the FLAT side of the PTO/Deck belt is the side coming in contact with the deck idler pulleys.

- With the tension relieved, carefully route the belt around the electric PTO clutch as shown in Figure 4.

IMPORTANT: After mounting the cutting deck, refer to **Leveling the Deck** in the **ADJUSTMENTS** section of this manual. Perform any adjustments, if necessary, prior to operating the tractor.

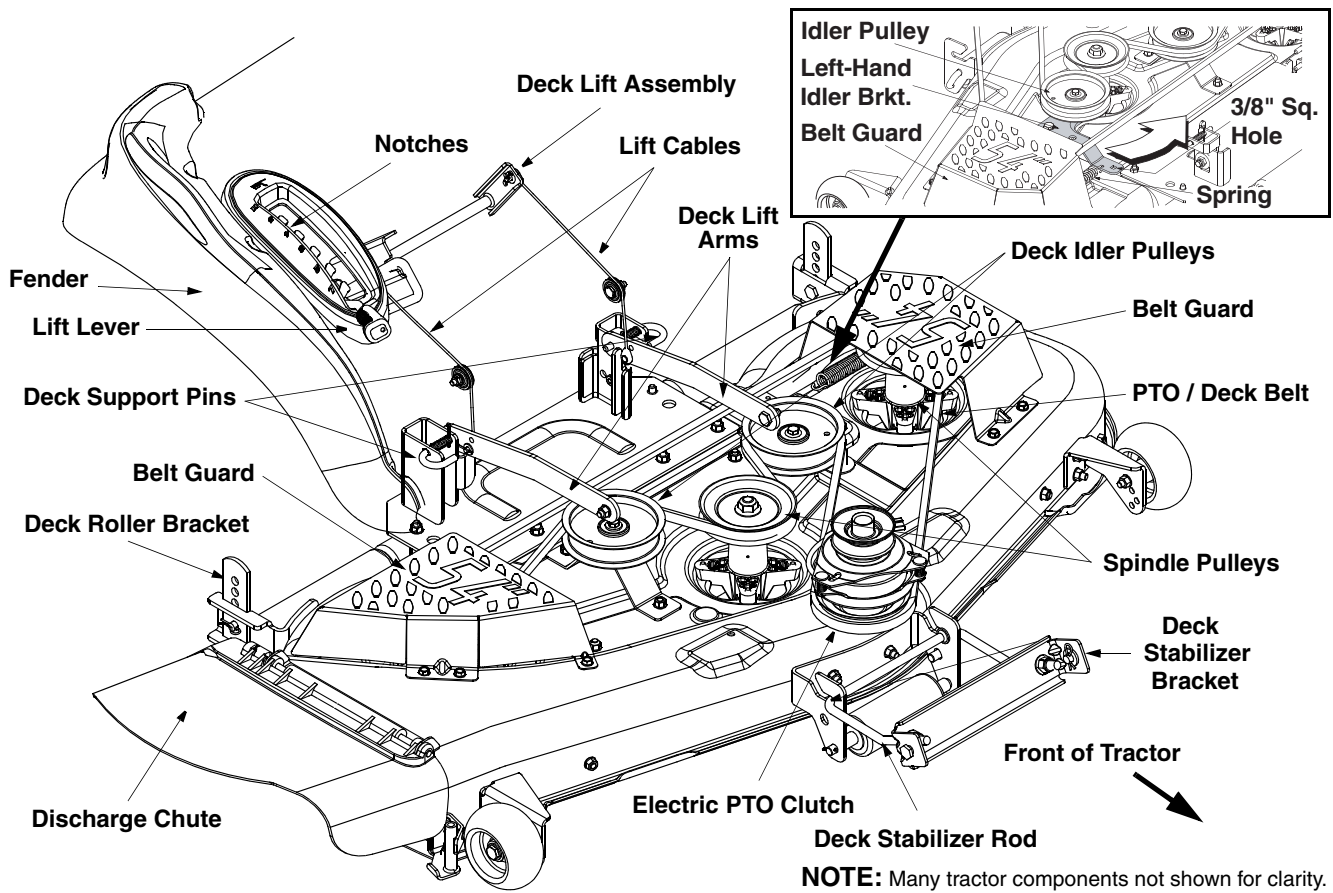
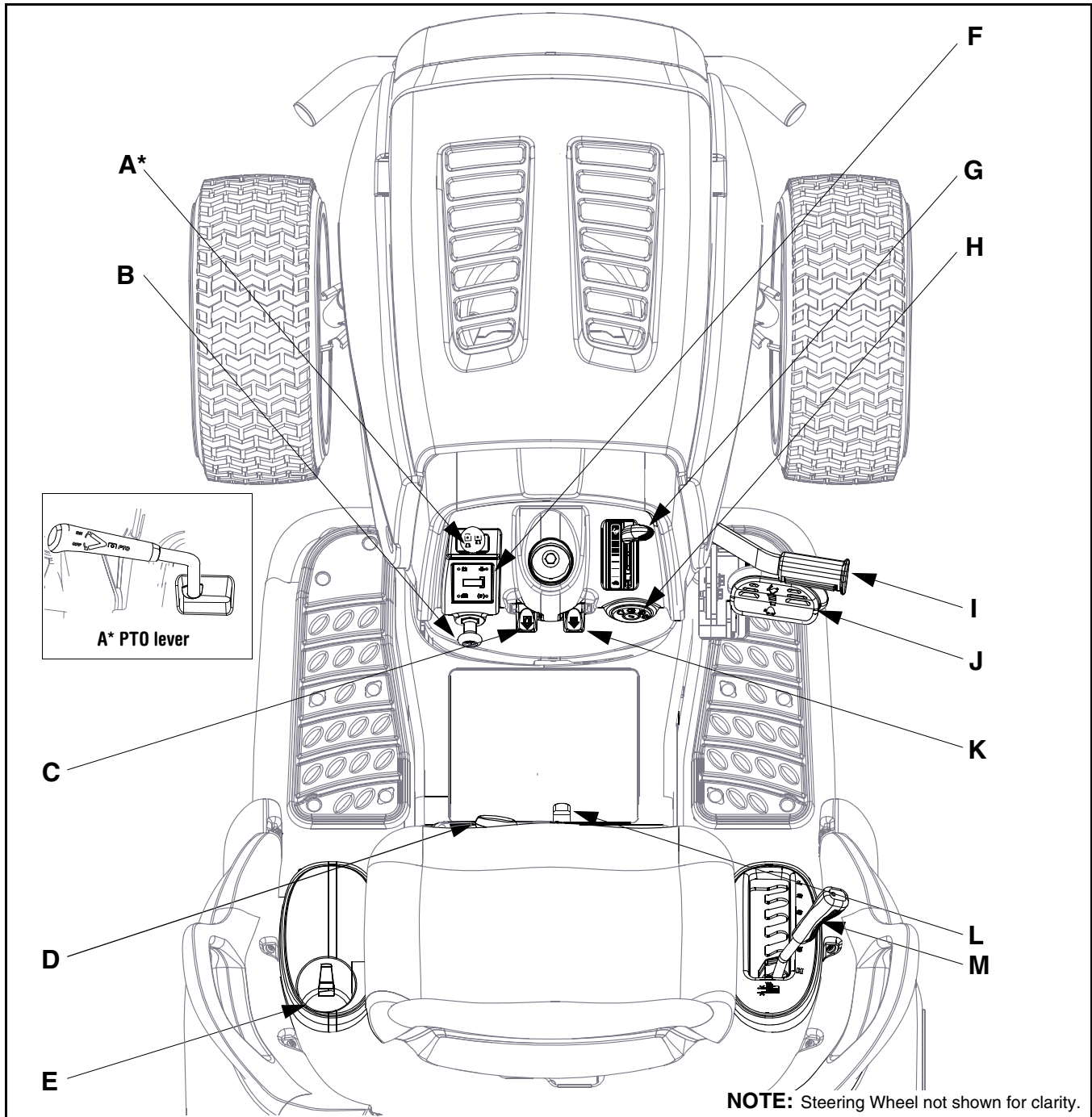

Figure 4

NOTE: Many tractor components not shown for clarity.

SECTION 5: CONTROLS



- | | |
|---|---------------------------------|
| A* PTO (Power Take-off) Lever (Models with manual PTO) | G Throttle Control Lever |
| PTO (Power Take-off) Knob (Models with electric PTO) | H Ignition Switch |
| B Choke Control | I Brake Pedal |
| C Parking Brake Button | J Drive Pedal |
| D Shift Lever | K Cruise Control Button |
| E Cup Holder | L Seat Adjustment Lever |
| F Systems Indicator Monitor/Hour Meter | M Deck Lift Lever |

NOTE: Any reference in this manual to the RIGHT or LEFT side of the tractor is observed from operator's position.

* Tractors vary by model and are equipped with either a PTO lever or a PTO knob, NEVER both.

THROTTLE CONTROL LEVER

The throttle control lever is located on the right side of the tractor's dash panel. This lever controls the speed of the engine and, on some models, when pushed all the way forward, the choke control also. When set in a given position, the throttle will maintain a uniform engine speed. See Figure 5.

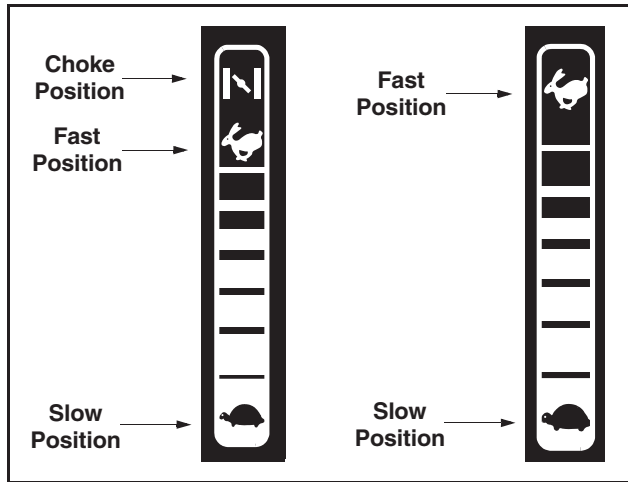
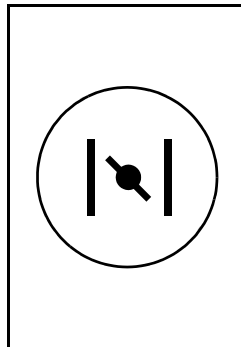

Figure 5

IMPORTANT: When operating the tractor with the cutting deck engaged, be certain that the throttle lever is always in the FAST (rabbit) position.

CHOKE CONTROL

The choke control can be found on the left side of the dash panel and is activated by pulling the knob outward. Activating the choke control closes the choke plate on the carburetor and aids in starting the engine. Refer to STARTING THE ENGINE in the OPERATION section of this manual for detailed starting instructions.



BRAKE PEDAL

The brake pedal is located on the right front side of the tractor above the drive pedal along the running board. The brake pedal can be used for sudden stops or setting the parking brake.

NOTE: The brake pedal must be fully depressed to activate the safety interlock switch when starting the tractor.

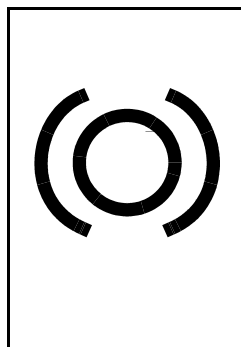

IGNITION SWITCH



WARNING: Never leave a running machine unattended. Always disengage PTO, move shift lever into neutral position, set parking brake, stop engine and remove key to prevent unintended starting.

To start the engine, insert the key into the ignition switch and turn clockwise to the **START** position. Release the key into the **NORMAL MOWING MODE** position once the engine has fired.

To stop the engine, turn the ignition key counterclockwise to the STOP position. See Figure 6.

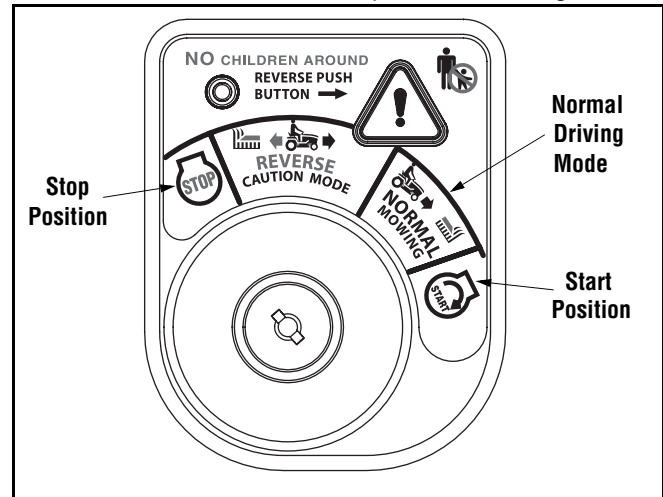
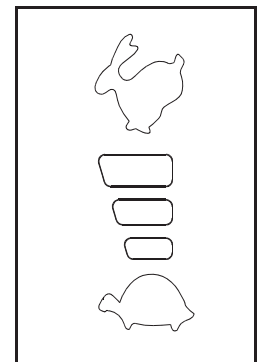

Figure 6

IMPORTANT: Prior to operating the tractor, refer to both **Safety Interlock Switches, page 14** and **Starting The Engine, page 15** of this manual for detailed instructions regarding the Ignition Switch Module and operating the tractor in **REVERSE CAUTION MODE**.

DRIVE PEDAL

The drive pedal is located below the brake pedal on the right front side of the tractor along the running board. Depress the drive pedal with your right foot when the tractor shift lever is in either FORWARD or REVERSE to cause the tractor to move. Ground speed is also controlled with the drive pedal. The further down the pedal is depressed, the faster the tractor will travel. The pedal will return to its original position when it's not depressed.



IMPORTANT: Always set the parking brake when leaving the tractor unattended.

SYSTEMS INDICATOR MONITOR / HOUR METER

Your tractor is equipped with either an hour meter or an ammeter as part of two available system indicator monitors. Locate the monitor on the left side of your dash panel and compare it to both shown in Figure 7.

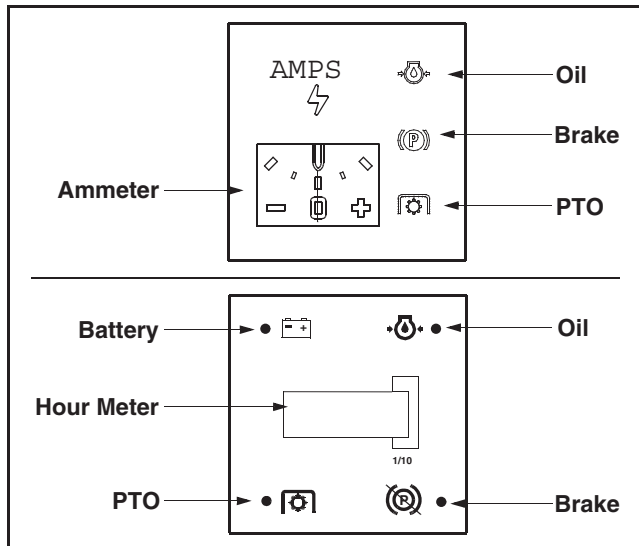

Figure 7

If the Brake light or PTO light illuminates when attempting to start the unit, proceed as follows:

- Brake** — Engage the parking brake.
- PTO** — Move the PTO lever into the disengaged (Blade Stop) position.

It is normal for the Oil light and the Battery light to illuminate while the engine is **cranking**, but if either illuminates while the **engine is running**, proceed as follows:

- Oil**— Stop the tractor immediately and check the crankcase oil level as instructed in the Engine Owner's Manual included with your unit. Add oil as required.
- Battery**— If this light illuminates while the engine is running, it indicates that the battery is in need of a charge OR that the engine's charging system is not generating sufficient amperage. Refer to the MAINTENANCE section of this manual for the proper battery charging procedure or have the engine's charging system checked by a *authorized* dealer.

On units so equipped, **the ammeter** measures the electrical output of the engine's charging system. Under normal operating conditions, with the engine at full throttle, the ammeter's needle should measure a positive charge.

The **hour meter**, on units so equipped, operates whenever the engine is running and records the actual hours of tractor operation.

ELECTRIC PTO (POWER TAKE-OFF) KNOB

To engage the power to the cutting deck or other (separately available) attachments on models so equipped with an electric PTO, pull outward on the PTO knob. Push the PTO knob inward to disengage the power to the cutting deck.

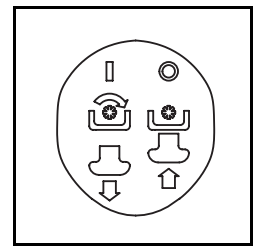

NOTE: The PTO knob **must** be in the disengaged (Blade Stop) position when starting the engine.

PTO (POWER TAKE-OFF) LEVER

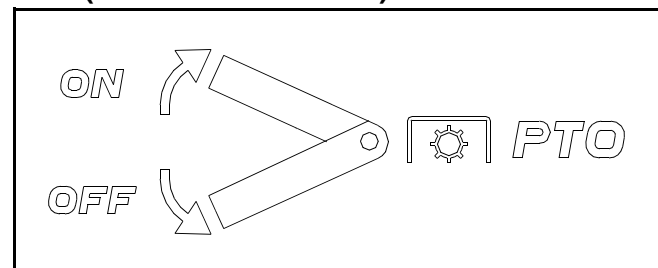

On models equipped with a manual PTO, the PTO lever is located on the left side of the dashboard next to the steering wheel. Move the PTO lever forward to engage the power to the cutting deck or other (separately available) attachments; move the PTO lever rearward to disengage the power.

NOTE: The PTO lever **must** be in the disengaged (Blade Stop) position when starting the engine.

SEAT ADJUSTMENT LEVER

To adjust the seat forward or backward on units equipped with a quick-adjust seat, slide the seat adjustment lever to the left and reposition the seat to the desired position. Once a comfortable position is found, release the seat adjustment lever to lock the seat in place. Refer to SEAT ADJUSTMENTS in the MAKING ADJUSTMENTS section of this manual for more detailed instructions.

DECK LIFT LEVER

Found on your tractor's right fender, the deck lift lever is used to change the height of the cutting deck. To use, move the lever to the left, then place in the notch best suited for your application.

CUP HOLDER

The tractor's cup holder is located on the fender to the left of the seat, just to the rear of the parking brake lever.

CRUISE CONTROL BUTTON

The cruise control button is located on the tractor dash panel to the left of the ignition switch. Push the cruise control button while traveling forward at a desired speed. While holding the button in, release pressure from the drive pedal. This will engage the cruise control and allow the tractor to remain at that speed without applying pressure to the drive pedal. Depress the brake pedal or the drive pedal to deactivate cruise control. Refer to OPERATION SECTION of this manual for detailed instructions regarding the cruise control feature.

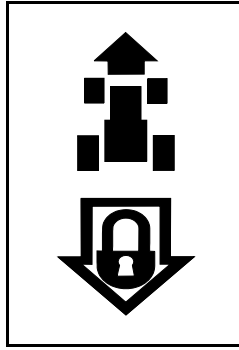

NOTE: Cruise control can NOT be engaged at the tractor's fastest ground speed. If the operator should attempt to do so, the tractor will automatically decelerate to the fastest optimal mowing ground speed.

PARKING BRAKE BUTTON

To set the parking brake, fully depress the brake pedal and push the parking brake button in. Hold the button in while taking your foot off the brake pedal. Both the parking button and the brake pedal will then stay depressed. To release the parking brake, depress the brake pedal slightly. The parking brake button will then return to its original position.

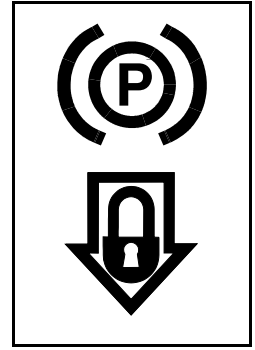

NOTE: The parking brake must be set if the operator leaves the seat with the engine running or the engine will automatically shut off.

IMPORTANT: Always set the parking brake when leaving the tractor unattended.

SECTION 6: OPERATING YOUR GARDEN TRACTOR



WARNING: Read, understand, and follow all instructions and warnings on the machine and in this manual before operating.

SAFETY INTERLOCK SWITCHES

This tractor is equipped with a safety interlock system for the protection of the operator. If the interlock system should ever malfunction, do not operate the tractor. Contact an authorized service dealer.

- The safety interlock system prevents the engine from cranking or starting unless the parking brake is engaged, and the PTO (Blade Engage) knob (or lever) is in the disengaged (Blade Stop) position.
- The engine will automatically shut off if the operator leaves the seat before engaging the parking brake.

Models with Manual PTO (Blade Engage)

- The engine will automatically shut off if the operator leaves the tractor's seat with the PTO (Blade Engage) lever in the engaged (ON) position, regardless of whether the parking brake is engaged.
- With the ignition key in the **NORMAL MOWING** position, the engine will automatically shut off if the PTO (Blade Engage) lever is moved into the engaged (ON) position with the shift lever in Reverse.

Models with Electric PTO (Blade Engage)

- The electric PTO (Blade Engage) clutch will automatically shut off if the operator leaves the tractor's seat with the PTO (Blade Engage) knob in the engaged (ON) position, regardless of whether the parking brake is engaged.



WARNING

AVOID SERIOUS INJURY OR DEATH

- GO UP AND DOWN SLOPES, NOT ACROSS.
- AVOID SUDDEN TURNS.
- DO NOT OPERATE THE UNIT WHERE IT COULD SLIP OR TIP.
- IF MACHINE STOPS GOING UPHILL, STOP BLADE(S) AND BACK DOWNHILL SLOWLY.
- DO NOT MOW WHEN CHILDREN OR OTHERS ARE AROUND.
- NEVER CARRY CHILDREN, EVEN WITH BLADES OFF.
- LOOK DOWN AND BEHIND BEFORE AND WHILE BACKING.
- KEEP SAFETY DEVICES (GUARDS, SHIELDS, AND SWITCHES) IN PLACE AND WORKING.
- REMOVE OBJECTS THAT COULD BE THROWN BY THE BLADE(S).
- KNOW LOCATION AND FUNCTION OF ALL CONTROLS.
- BE SURE BLADE(S) AND ENGINE ARE STOPPED BEFORE PLACING HANDS OR FEET NEAR BLADE(S).
- BEFORE LEAVING OPERATOR'S POSITION, DISENGAGE BLADE(S), PLACE THE SHIFT LEVER IN NEUTRAL, ENGAGE BRAKE LOCK, SHUT ENGINE OFF AND REMOVE KEY.

READ OPERATOR'S MANUAL

- With the ignition key in the **NORMAL MOWING** position, the electric PTO (Blade Engage) clutch will automatically shut off if the PTO (Blade Engage) knob is moved into the engaged (ON) position with the shift lever in Reverse.



WARNING: Do not operate the tractor if the interlock system is malfunctioning. This system was designed for your safety and protection.

REVERSE CAUTION MODE

The **REVERSE CAUTION MODE** position of the key switch module allows the tractor to be operated in reverse with the blades (PTO) engaged.

IMPORTANT: *Mowing in reverse is not recommended.*



WARNING: Use extreme caution while operating the tractor in the **REVERSE CAUTION MODE**. Always look down and behind before and while backing. Do not operate the tractor when children or others are around. Stop the tractor immediately if someone enters the area.

To use the **REVERSE CAUTION MODE**:

IMPORTANT: *The operator MUST be seated in the tractor seat.*

1. Start the engine as previously instructed in this Operator's Manual.
2. Turn the key from the **NORMAL MOWING** (Green) position to the **REVERSE CAUTION MODE** (Yellow) position of the key switch module. See Figure 8.
3. Depress the **REVERSE PUSH BUTTON** (Orange, Triangular Button) at the top, right corner of the key switch module. The red indicator light at the top, left corner of the key switch module will be **ON** while activated. See Figure 8.
4. Once activated (indicator light **ON**), the tractor can be driven in reverse with the cutting blades (PTO) engaged.
5. Always look down and behind before and while backing to make sure no children are around.
6. After resuming forward motion, return the key to the **NORMAL MOWING** position.

IMPORTANT: The **REVERSE CAUTION MODE** will remain activated until:

- a. The key is placed in either the **NORMAL MOWING** position or **STOP** position.
- b. The operator leaves the seat (Models with Electric PTO ONLY).
- c. The operator engages the parking brake by fully depressing the brake pedal and holding it down while gently pushing the parking brake button inward (Models with Manual PTO ONLY).

SETTING THE CUTTING HEIGHT

Select the height position of the cutting deck by placing the deck lift lever in any of the six different cutting height notches on the right side of the fender. Then adjust the deck wheels so that they are between ¼-inch and ½-inch above the ground when the tractor is on a smooth, flat surface such as a driveway.



WARNING: Keep hands and feet away from the discharge opening of the cutting deck.

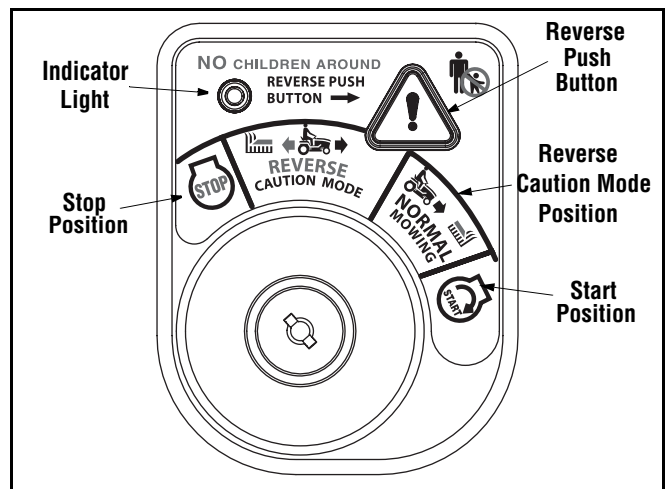

Figure 8

NOTE: *The deck wheels are an anti-scalp feature of the deck and are not designed to support the weight of the cutting deck.*

Refer to the **ADJUSTMENTS** section of this manual for more detailed instructions regarding various deck adjustments.

STARTING THE ENGINE



WARNING: Do not operate the tractor if the interlock system is malfunctioning. This system was designed for your safety and protection.

NOTE: *Refer to the TRACTOR SET-UP section of this manual for Gasoline and Oil fill-up instructions.*

- Insert the tractor key into the ignition switch.
- Place the PTO knob (or lever) in the disengaged (Blade Stop) position.
- Engage the tractor's parking brake.
- Place the throttle control in the FAST (rabbit) position.
- Pull the choke control outward.
- Turn the ignition key clockwise to the START position. After the engine starts, release the key. It will return to the **NORMAL MOWING** position.

IMPORTANT: Do **NOT** hold the key in the START position for longer than ten seconds at a time. Doing so may cause damage to your engine's electric starter.

NOTE: *If starting problems are encountered, refer to the TROUBLESHOOTING section of this manual.*

- After the engine starts, deactivate the choke control.

NOTE: *Do NOT leave the choke control on while operating the tractor. Doing so will result in a "rich" fuel mixture and cause the engine to run poorly.*

STOPPING THE ENGINE



WARNING: If you strike a foreign object, stop the engine, disconnect the spark plug wire(s) and ground against the engine. Thoroughly inspect the machine for any damage. Repair the damage before restarting and operating

- If the blades are engaged, place the PTO/Blade Engage knob (or lever) in the disengaged (Blade Stop) position.
- Turn the ignition key counterclockwise to the STOP position.
- Remove the key from the ignition switch to prevent unintended starting.

ENGAGING THE PARKING BRAKE

To engage the parking brake:

- Fully depress the brake pedal and hold it there while gently pushing the parking brake button inward.
- Hold the parking brake button in while removing your foot from the brake pedal.
- Once engaged, the parking brake button and the brake pedal will lock in the “down” position.

To disengage the parking brake:

- Slightly depress the brake pedal.

NOTE: *The parking brake must be engaged if the operator leaves the seat with the engine running or the engine will automatically shut off.*

DRIVING THE TRACTOR



WARNING: Avoid sudden starts, excessive speed and sudden stops.



WARNING: Do not leave the seat of the tractor without first placing the PTO knob (or lever) in the disengaged (Blade Stop) position, depressing the brake pedal and engaging the parking brake. If leaving the tractor unattended, also turn the ignition key off and remove the key.

- Depress the brake pedal to release the parking brake and let the pedal up.
- Move the throttle lever into the FAST (rabbit) position.
- To move forward, place the shift lever in the FORWARD position, then slowly depress the drive pedal until the desired speed is achieved.
- To move in reverse, place the shift lever in the REVERSE position, check that the area behind is clear then slowly depress the drive pedal.

IMPORTANT: Do NOT use the shift lever to change the direction of travel when the tractor is in motion.

Always use the brake pedal to bring the tractor to a complete stop before shifting.

DRIVING ON SLOPES

Refer to the SLOPE GAUGE on page 7 to help determine slopes where you may not operate safely.



WARNING: Do not mow on inclines with a slope in excess of 15 degrees (a rise of approximately 2-1/2 feet every 10 feet). The tractor could overturn and cause serious injury.

- Mow up and down slopes, **NEVER** across.
- Exercise extreme caution when changing direction on slopes.
- Watch for holes, ruts, bumps, rocks, or other hidden objects. Uneven terrain could overturn the machine. Tall grass can hide obstacles.
- Avoid turns when driving on a slope. If a turn must be made, turn down the slope. Turning up a slope greatly increases the chance of a roll over.
- Avoid stopping when driving up a slope. If it is necessary to stop while driving up a slope, start up smoothly and carefully to reduce the possibility of flipping the tractor over backward.

SETTING THE CRUISE CONTROL

NOTE: *The cruise control feature should only be utilized while traveling in the forward direction.*

- Place the shift lever in the FORWARD position, then slowly depress the drive pedal until the desired speed is achieved.
- Lightly depress the cruise control button.
- While continuing to hold the cruise button in, lift your foot from the drive pedal (you should feel the cruise latch engage).
- Once engaged, the cruise control button and the drive pedal will lock in the “down” position, and the tractor will maintain the same forward speed.

NOTE: *Cruise control cannot be engaged at the tractor's fastest ground speed. If the operator should attempt to do so, the tractor will automatically decelerate to the fastest optimal mowing ground speed.*

Disengage the cruise control using one of the following methods:

- Depress the brake pedal to disengage the cruise control and stop the tractor.
- Lightly depress the drive pedal.

To change the direction of travel to reverse when operating with cruise control, depress the brake pedal to disengage the cruise control and bring the tractor to a complete stop. Place the shift lever in the REVERSE position, check that the area behind is clear then slowly depress the drive pedal.

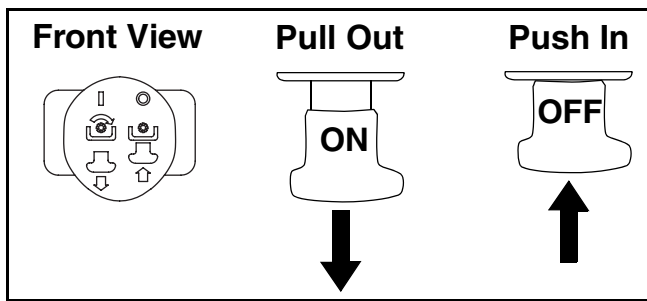

Figure 9

ENGAGING THE PTO

Engaging the PTO transfers power to the cutting deck or other (separately available) attachments. To engage the PTO, proceed as follows:

- Move the throttle control lever to the FAST (rabbit) position.

Models with manual PTO

- Grasp the PTO lever and pivot it all the way forward into the engaged (ON) position.

Models with electric PTO

- Pull the PTO knob outward into the engaged (ON) position. See Figure 9.

NOTE: Keep the throttle lever in the FAST (rabbit) position for the most efficient use of the cutting deck or other (separately available) attachments.

IMPORTANT: The engine or electric PTO clutch will automatically shut off if the PTO is engaged with the drive pedal in position for reverse travel. Refer to SAFETY INTERLOCK SWITCHES earlier in this section.

- To disengage the PTO, push the PTO knob in, or move the PTO lever to the “Blade Stop” position. This will cut off power to deck or other attachments.

USING THE LIFT LEVER

To raise the cutting deck, move the lift lever to the left, then place it in the notch best suited for your application. Refer to SETTING THE CUTTING HEIGHT earlier in this section.

MOWING



WARNING: To help avoid blade contact or a thrown object injury, keep bystanders, helpers, children and pets at least 75 feet from the machine while it is in operation. Stop machine if anyone enters the area.

This tractor is equipped with a high quality cutting deck. The following information will be helpful when using the cutting deck with your tractor.

- Do not mow at high ground speed, especially if a mulch kit or grass collector is installed.



WARNING: Plan your mowing pattern to avoid discharge of materials toward roads, sidewalks, bystanders and the like. Also, avoid discharging material against a wall or obstruction which may cause discharged material to ricochet back toward the operator.

- For best results it is recommended that the first two laps be cut with the discharge thrown towards the center. After the first two laps, reverse the direction to throw the discharge to the outside for the balance of cutting. This will give a better appearance to the lawn.
- Do not cut the grass too short. Short grass invites weed growth and yellows quickly in dry weather.
- Mowing should always be done with the engine at full throttle.
- Under heavier conditions it may be necessary to go back over the cut area a second time to get a clean cut.
- Do NOT attempt to mow heavy brush and weeds and extremely tall grass. Your tractor is designed to mow lawns, NOT clear brush.
- Keep the blades sharp and replace the blades when worn. Refer to the SERVICE section of this manual for proper blade sharpening instructions.

MULCHING

Tractors come equipped with a mulch kit which incorporates special blades, already standard on your tractor, in a process of recirculating grass clippings repeatedly beneath the cutting deck. The ultra-fine clippings are then forced back into the lawn where they act as a natural fertilizer. Observe the following recommendations for the best results when mulching.

- Never attempt to mulch if the lawn is damp. Wet grass tends to stick to the underside of the cutting deck preventing proper mulching of the clippings.
- Do NOT attempt to mulch more than 1/3 the total height of the grass or approximately 1-1/2 inches. Doing so will cause the clippings to clump up beneath the deck and not be mulched effectively.
- Maintain a slow ground speed to allow the grass clippings more time to effectively be mulched.
- Always position the throttle control lever in the FAST (rabbit) position and allow it to remain there while mowing. Failing to keep the engine at full throttle places strain on the tractor’s engine and does not allow the blades to properly mulch grass.

NOTE: It is not necessary to remove the discharge chute to operate the mower with the mulch kit installed.

The mulch kit is packed separately (with an instruction sheet) within the tractor’s crate. Observe the instructions included with the mulch kit for the best results when mulching.

HEADLIGHTS

On some models, the lamps are ON whenever the tractor's engine is running. On other models, the lamps are ON whenever the ignition key is moved out of the STOP position.

On all models, the lamps turn OFF when the ignition key is moved to the STOP position.

NOTE: Never move the key into the Start position while the engine is running. Doing so may cause damage to your engine's electric starter.

SECTION 7: MAKING ADJUSTMENTS



WARNING: Never attempt to make any adjustments while the engine is running, except where specified in the operator's manual.



WARNING: Disconnect the spark plug wire(s) and ground against the engine before performing any adjustments, repairs or maintenance.

LEVELING THE DECK

NOTE: Check the tractor's tire pressure before performing any deck leveling adjustments. Refer to TIRES in the maintenance section of this manual for further information regarding tire pressure.

Front To Rear

The front of the cutting deck is supported by a stabilizer bar that can be adjusted to level the deck from front to rear. The front of the deck should be between 1/4-inch and 3/8-inch lower than the rear of the deck. Adjust if necessary as follows:

- With the tractor parked on a firm, level surface, place the deck lift lever in the top notch (highest position) and rotate the blade nearest the discharge chute so that it is parallel with the tractor.
- Measure the distance from the front of the blade tip to the ground and the rear of the blade tip to the ground.
- The first measurement taken should be between 1/4" and 3/8" less than the second measurement.
- Determine the approximate distance necessary for proper adjustment and proceed, if necessary, to the next step.
- Loosen the jam nuts on the rear side of the deck stabilizer bracket. See Figure 10A.
- Locate the lock nuts on the opposite side of the stabilizer bracket. See Figure 10A. Tighten the lock nuts to raise the front of the deck; loosen the lock nuts to lower the front of the deck.
- Retighten the jam nuts loosened earlier when proper adjustment is achieved.

Side to Side

If the cutting deck appears to be mowing unevenly, a side to side adjustment can be performed. Adjust if necessary as follows:

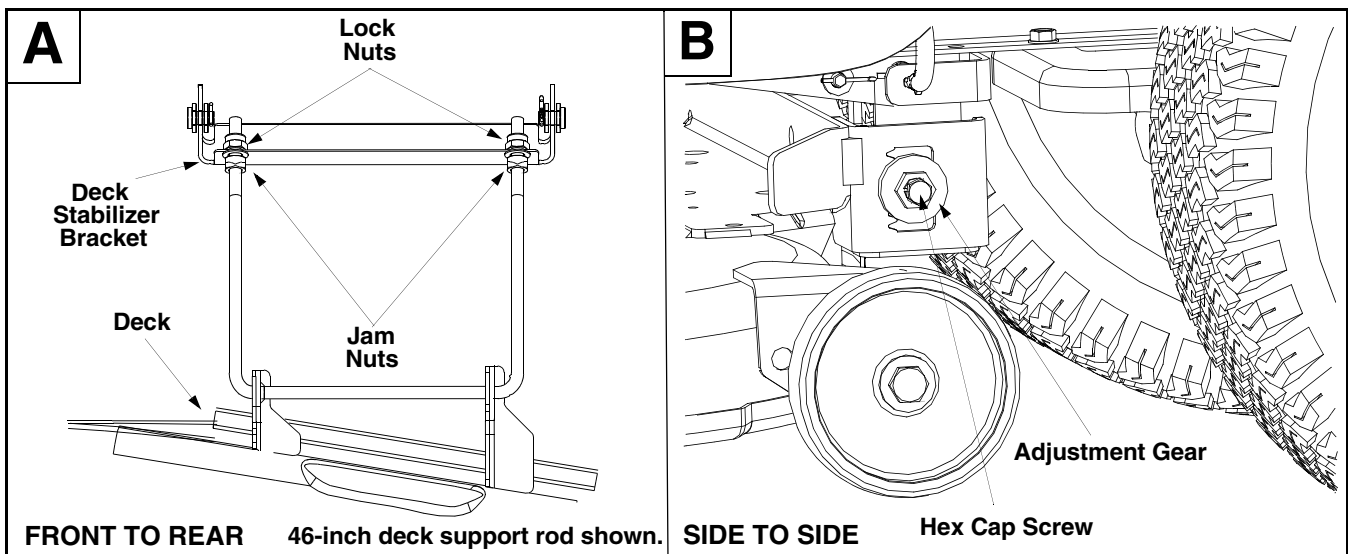

Figure 10

- With the tractor parked on a firm, level surface, place the deck lift lever in the top notch (highest position) and rotate both blades so that they are perpendicular with the tractor.
- Measure the distance from the outside of the left blade tip to the ground and the distance from the outside of the right blade tip to the ground. Both

measurements taken should be equal. If they're not, proceed to the next step.

- Loosen, but do **NOT** remove, the hex cap screw on the left deck hanger bracket. See Figure 10B.
- Balance the deck by using a wrench to turn the adjustment gear (found immediately behind the hex cap screw just loosened) clockwise/up or counterclockwise/down.
- The deck is properly balanced when both blade tip measurements taken earlier are equal.
- Retighten the hex cap screw on the left deck hanger bracket when proper adjustment is achieved.

DECK ROLLER HEIGHT ADJUSTMENT

To adjust the height of the rollers on the rear of the mowing deck, proceed as follows:

- Place the deck lift lever in the bottom notch (lowest position).
- Remove the clevis pins and hairpin clips from the deck roller brackets on the left and right sides of the cutting deck. See Figure 11.

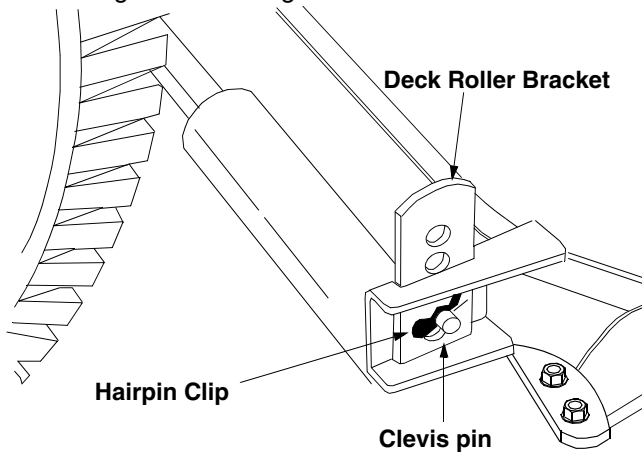

Figure 11

- Position the deck roller brackets up or down through the slots on the rear of the deck until desired position is reached, then re-attach with the clevis pins and hairpin clips just removed. See Figure 11.

NOTE: Be certain that the left roller bracket and the right roller bracket are set in the same position.

SEAT ADJUSTMENT



WARNING: Before operating this machine, make sure the seat is engaged in the seat stop, stand behind the machine and pull back on seat until fully engaged into stop.

Quick-Adjust Seat

To adjust the position of the seat, move the seat adjustment lever to the left and slide the seat forward or rearward. Make sure seat is locked into position before operating the tractor. See Figure 12.

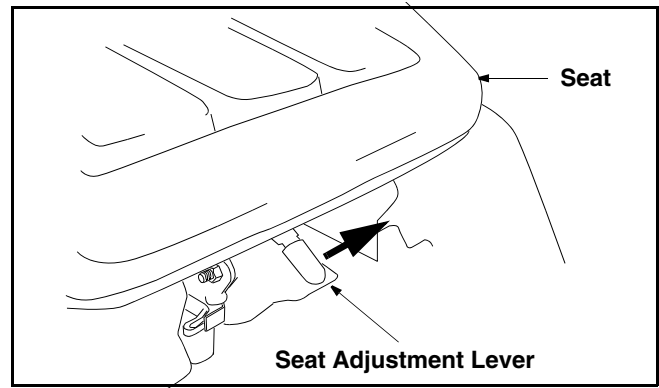

Figure 12

PARKING BRAKE ADJUSTMENT



Never attempt to adjust the brakes while the engine is running. Always disengage PTO, move shift lever into neutral position, stop engine and remove key to prevent unintended starting.

If the tractor does not come to a complete stop when the brake pedal is completely depressed, or if the tractor's rear wheels can roll with the parking brake applied, the brake is in need of adjustment. The brake disc can be found on the right side of the transmission in the rear of the tractor. Adjust if necessary as follows:

- Looking at the transmission from the right side of the tractor, locate the compression spring and brake disc.
- Loosen, but do **NOT** remove, the hex nut found on the right side of the brake assembly.
- Using a feeler gauge, set the gap between the brake disc and the brake puck at 0.011 inches.
- Re-tighten the hex nut loosened earlier.

STEERING ADJUSTMENT

If the tractor turns tighter in one direction than the other, or if the ball joints are being replaced due to damage or wear, the steering drag links may need to be adjusted.

Adjust the drag links so that equal lengths are threaded into the ball joint on the left side and the ball joint on the right side:

- Loosen the jam nut found on the drag link at the rear of the ball joint. See Figure 13.
- Remove the hex nut and lock washer on the top of ball joint. See Figure 13.
- Thread the ball joint toward the jam nut to shorten the drag link. Thread the ball joint away from the jam nut to lengthen the drag link.
- Replace hex nut and lock washer and retighten the jam nut after proper adjustment is achieved.

NOTE: Threading the ball joints too far onto the drag links will cause the front tires to "toe-in" too far. Proper toe-in is between 1/16" and 5/16".

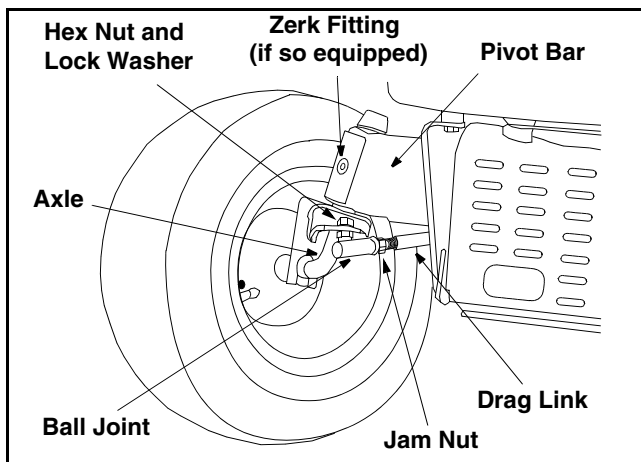

Figure 13

Front tire toe-in can be measured as follows:

- Place the steering wheel in position for straight ahead travel.
- In front of the axle, measure the distance horizontally from the inside of the left rim to the inside of the right rim. Note the distance.
- Behind the axle, measure the distance horizontally from the inside of the left rim to the inside of the right rim. Note the distance.
- The measurement taken in front of the axle should be between 1/16" and 5/16" less than the measurement taken behind the axle.
- Adjust if necessary.

SECTION 8: MAINTENANCE



WARNING: Before performing any maintenance or repairs, disengage PTO, move shift lever into neutral position, set parking brake, stop engine and remove key to prevent unintended starting.

CLEANING THE ENGINE AND DECK

Any fuel or oil spilled on the machine should be wiped off promptly.

Do NOT allow debris to accumulate around the cooling fins of the engine or on any other part of the machine, especially the belts and pulleys.

IMPORTANT: The use of a pressure washer or garden hose to clean your tractor is NOT recommended. It may cause damage to electrical components, spindles, pulleys, bearings or the engine. The use of water will result in a shortened life of the tractor and reduce its serviceability.

Deck Wash System™ (Optional)

A hex plug can be found on your tractor's deck surface.

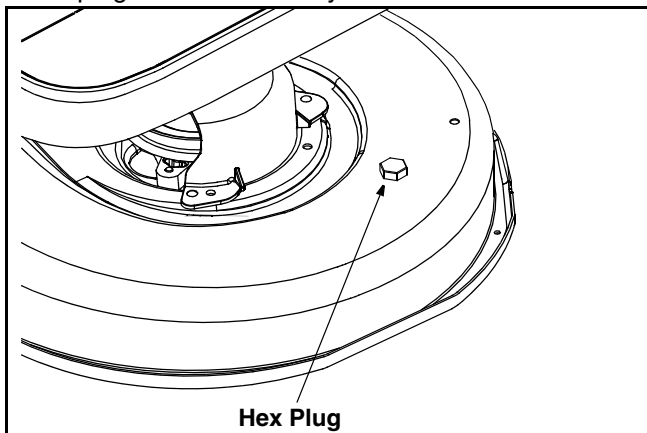

This plug can be replaced with a water port to be used as part of a separately-available deck wash system.

Use the Deck Wash System to rinse grass clippings from the deck's underside and prevent build-up of corrosive chemicals. Refer to page 6 for information regarding this and other separately-available attachments & accessories for your tractor. Complete the following steps after each mowing:

1. Drive the tractor to a level, clear spot on your lawn, near enough to a water sillcock (spigot) for your garden hose to reach.

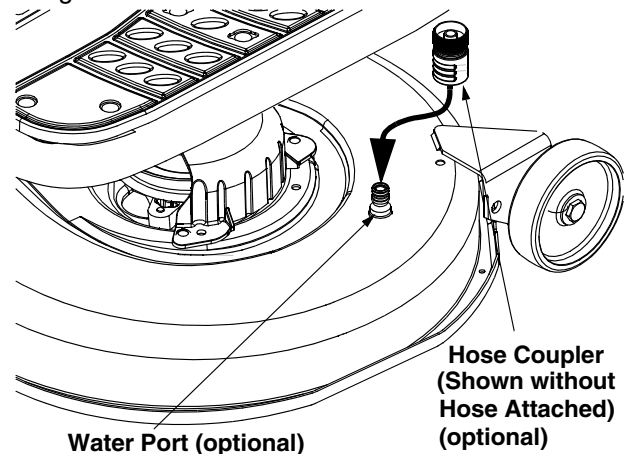

Figure 14

IMPORTANT: Make certain the tractor's discharge chute is directed away from your house, parked cars, etc.

2. Disengage PTO, move shift lever into the neutral position, set the parking brake, and stop engine.
3. Thread the hose coupler (packaged with this manual) onto the end of your garden hose.
4. Attach the hose coupler to the water port on your deck's surface. See Figure 14.
5. Turn the water on.
6. While sitting in the operator's position on the tractor, re-start the engine and place the throttle lever in the FAST (rabbit) position.

7. Engage the tractor's PTO.
8. **Remain in the operator's position** with the cutting deck engaged for a minimum of two minutes, allowing the underside of the cutting deck to thoroughly rinse.
9. Disengage the tractor's PTO.
10. Turn the ignition key to the STOP position to turn the tractor's engine off.
11. Turn the water off and detach the hose coupler from the water port on your decks surface. Repeat step 4-11 on the opposite side of the cutting deck.

ENGINE

Refer to the separate engine manual for engine maintenance instructions.

Check **engine oil level** before each use as instructed in the separate engine manual packed with your unit.

Read and follow instructions carefully.

CHANGING ENGINE OIL

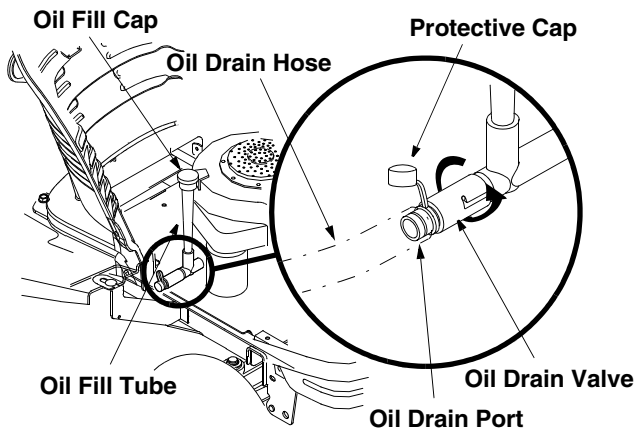

NOTE: Single-cylinder engine shown.
Valve location will vary with engine style.

Figure 15

NOTE: Depending on the engine model found on your tractor, it may be necessary to remove the tractor's side panel in order to replace the oil filter (if so equipped).

- Unscrew oil fill cap and remove dipstick from the oil fill tube. See Figure 15.
- Pop open the protective cap on the end of the oil drain valve to expose the oil drain port. See Figure 15.
- Push oil drain hose (packed with unit) onto the oil drain port. Route the opposite end of the hose into an appropriate oil collection container with a capacity great enough to collect the used oil.
- Push the oil drain valve in slightly, then rotate counterclockwise and pull outward to begin draining oil. See Figure 15.
- Service the **oil filter** (if so equipped) as instructed in the separate engine manual packed with your unit.

Perform the above steps in the opposite order after oil has finished draining.

- Refill the engine with new motor oil.

IMPORTANT: Refill the engine with the proper capacity and weight of motor oil as instructed in the separate engine manual.

Service **air cleaner** every 25 hours under normal conditions. Clean every few hours under extremely dusty condition. To service the air cleaner, refer to the separate engine manual packed with your unit.

The **spark plug(s)** should be cleaned and the gap reset once a season. Spark plug replacement is recommended at the start of each mowing season; check engine manual for correct plug type and gap specifications.

SECTION 9: LUBRICATION



WARNING: Before lubricating, repairing, or inspecting, always disengage PTO, move shift lever into neutral position, set parking brake, stop engine and remove key to prevent unintended starting.

Engine

Lubricate the engine with motor oil as instructed in the Engine Owner's Manual packed with your unit.

Pivot Points & Linkage

Lubricate all the pivot points on the drive system, parking brake and lift linkage at least once a season with light oil.

Front Wheels

Each of the front wheel axles is equipped with a grease fitting. Lubricate with a grease gun after every 25 hours of tractor operation.

Rear Wheels

The rear wheels should be removed from the axles once a season. Lubricate the axles and the rims well with an all-purpose grease before re-installing them.

SECTION 10: SERVICE

TIRES



WARNING: Never exceed the maximum inflation pressure shown on the sidewall of the tire.

The recommended operating tire pressure is 10 psi for the rear tires and 14 psi for the front tires. Refer to the tire sidewall for exact tire manufacturer's recommended or maximum psi. Do not overinflate. Uneven tire pressure could cause the cutting deck to mow unevenly.

CUTTING BLADES



WARNING: Be sure to shut the engine off, remove ignition key, disconnect the spark plug wire(s) and ground against the engine to prevent unintended starting before removing the cutting blade(s) for sharpening or replacement. Protect your hands by using heavy gloves or a rag to grasp the cutting blade.



WARNING: Periodically inspect the blade adapter and/or spindle for cracks or damage, especially if you strike a foreign object. Replace immediately if damaged.

The blades may be removed as follows.

- Remove the deck from beneath the tractor, (refer to DECK REMOVAL) then gently flip the deck over to expose its underside.
- Place a block of wood between the center deck housing baffle and the cutting blade to act as a stabilizer. See Figure 16.
- Use a 15/16" wrench to remove the hex flange nut that secures the blade to the spindle assembly. See Figure 16.

To properly sharpen the cutting blades, remove equal amounts of metal from both ends of the blades along the cutting edges, parallel to the trailing edge, at a 25° to 30° angle. See Figure 17.

IMPORTANT: If the cutting edge of the blade has already been sharpened to within 5/8" of the wind wing radius, or if any metal separation is present, replace the blades with new ones. See Figure 17.

It is important that each cutting blade edge be ground equally to maintain proper blade balance.

A poorly balanced blade will cause excessive vibration and may cause damage to the tractor and result in personal injury.

The blade can be tested by balancing it on a round shaft screwdriver. Grind metal from the heavy side until it balances evenly.

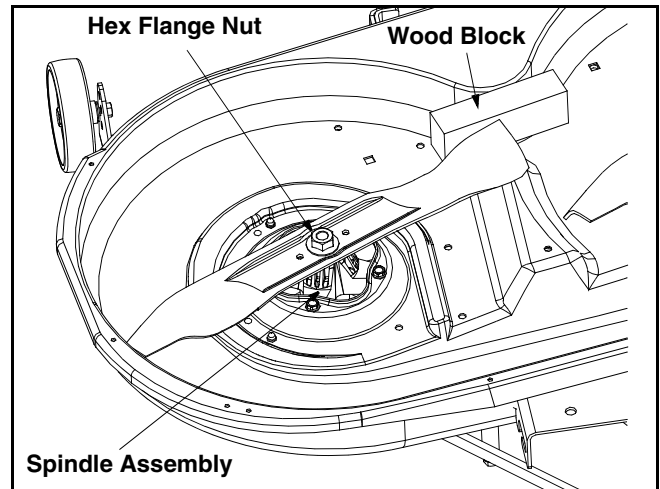

Figure 16

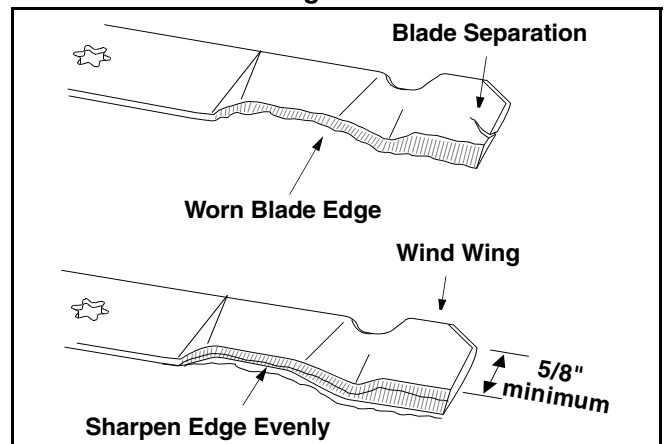

Figure 17

IMPORTANT: When replacing the blade, be sure to install the blade with the side of the blade marked "Bottom" (or with a part number stamped in it) facing the ground when the mower is in the operating position.

IMPORTANT: Use a torque wrench to tighten blade spindle hex flange nut to between 70 ft-lbs and 90 ft-lbs

BATTERY

The battery is sealed and is maintenance-free. Acid levels cannot be checked.



WARNING: Shield eyes (e.g. goggles, face shield) and protect skin and clothing when handling battery acid or a battery containing acid.

- Always keep the battery cables and terminals clean and free of corrosive build-up.
- After cleaning the battery and terminals, apply a light coat of petroleum jelly or grease to both terminals.
- Always keep the rubber boot positioned over the positive terminal to prevent shorting.

IMPORTANT: If removing the battery for any reason, disconnect the NEGATIVE (Black) wire from its terminal first, followed by the POSITIVE (Red) wire. When re-installing the battery, always connect the POSITIVE (Red) wire its terminal first, followed by the NEGATIVE (Black) wire. Be certain that the wires are connected to the correct terminals; reversing them could change the polarity and cause damage to your engine's alternating system.

IMPORTANT:

1. Battery wires must be connected to the correct terminals. Reversing them could change the polarity and damage engine's alternating system.
2. Do not jump-start a damaged battery.
3. When storing the battery, disconnect the negative terminal and store with full charge.

CHARGING

If the unit has not been put into use for an extended period of time, charge the battery with an automotive-type 12-volt charger for a minimum of one hour at six amps.



WARNING: Batteries give off an explosive gas while charging. Charge battery in a well ventilated area and keep away from an open flame or pilot light as on a water heater, space heater, furnace, clothes dryer or other gas appliances.

JUMP STARTING



WARNING: When removing or installing the battery, follow these instructions to prevent the screwdriver from shorting against the frame.

IMPORTANT: Never jump your tractor's dead battery with the battery of a running vehicle.

- Connect end of one jumper cable to the positive terminal of the good battery, then the other end to the positive terminal of the dead battery.
- Connect the other jumper cable to the negative terminal of the good battery, then to the frame of the unit with the dead battery.



WARNING: Failure to use this procedure could cause sparking, and the gas in either battery could explode.



WARNING: Do not use the tractor battery to start other vehicles.

Cleaning the battery

Keep the terminals and the top of the battery clean and free from corrosion. Clean the battery with baking soda and water or a commercial battery cleaner. If necessary, scrape the battery terminals with a wire brush to remove deposits. Coat terminals and exposed wiring with grease or petroleum jelly to prevent corrosion.

CAUTION: Do not allow any cleaning solution to get inside the battery.

BATTERY FAILURES

Some common causes for battery failure are:

- incorrect initial activation
- undercharging
- overcharging
- corroded connections
- freezing

These failures are NOT covered by your tractor's warranty.

FUSES

Two fuses are installed in your tractor's wiring harness to protect the tractor's electrical system from damage caused by excessive amperage.

If the electrical system does not function, or your tractor's engine will not crank, first check to be certain that the fuse has not blown. See Figure 18.

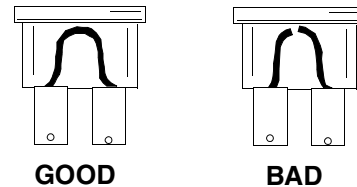

Figure 18

One can be found under the hood mounted behind the top of the dash panel on the support bar.

The other can be found under the seat mounted to the inside of the tractor frame next to the battery tray. Pull the fuse out and inspect it to determine if it is good or blown.



WARNING: Always use a fuse with the same amperage capacity for replacement.

CUTTING DECK REMOVAL

To properly remove the cutting deck, proceed as follows:

- Place the PTO/Blade Engage knob (or lever) in the disengaged (Blade Stop) position and engage the parking brake.
- Lower the deck by moving the deck lift lever into the bottom notch on the right fender.
- Remove the PTO belt from around the electric PTO clutch and from around the PTO idler pulley(s).

NOTE: The deck belt on the deck does NOT need to be removed in order to remove the deck.

- Looking at the cutting deck from the left side of the tractor, locate the deck support pin on the rear left side of the deck.
- Pull the deck support pin outward to release the deck from the deck lift arm. See Figure 19.

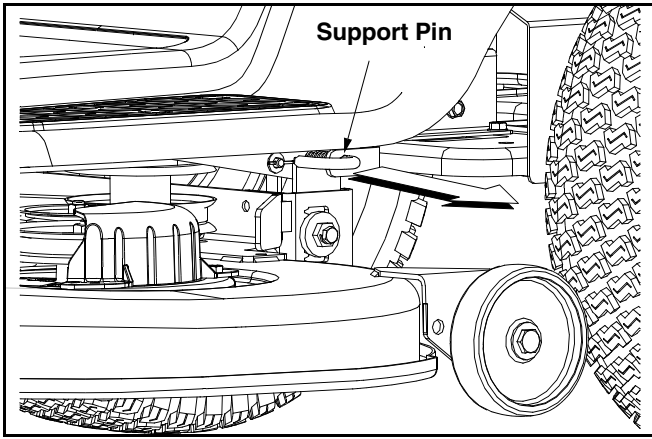

Figure 19

IMPORTANT: Rotate the pin slightly toward the rear of the tractor and release the pin into the hole provided.

- Repeat the above steps on the right side of the tractor.
- Move the deck lift lever into the top notch on the right fender to raise the lift arms out of the way.
- Gently slide the cutting deck toward the front of the tractor allowing the hooks on the deck to release themselves from the deck stabilizer rod.
- Gently slide the cutting deck (from the right side) out from underneath the tractor.

CHANGING THE DECK BELT & PTO BELT

IMPORTANT: The V-belts found on your tractor are specially designed to engage and disengage safely. A substitute (non-OEM) V-belt can be dangerous by not disengaging completely. For a proper working machine, use factory approved belts.



WARNING: Be sure to shut the engine off, remove ignition key, disconnect the spark plug wire(s) and ground against the engine to prevent unintended starting before removing the belt(s). All belts on your tractor are subject to wear and should be replaced if any signs of wear are present.



WARNING: Avoid the possibility of a pinching injury. Do not place your fingers on the idler spring or between the belt and the pulley while removing the belt.

To change or replace the deck belts on your tractor, proceed as follows:

- Lower the deck by moving the deck lift lever into the bottom notch on the right fender.
- Remove the belt guards by removing the self-tapping screws that fasten them to the deck.
- To ease in removing the belt in later steps, loosen, but do not remove, the bolt which secures the pivoting idler pulley to the idler bracket.
- Insert a 3/8"-drive ratchet wrench (set to *loosen*) into the square hole found in the idler bracket on the left side of the deck's surface. See Figure 20.

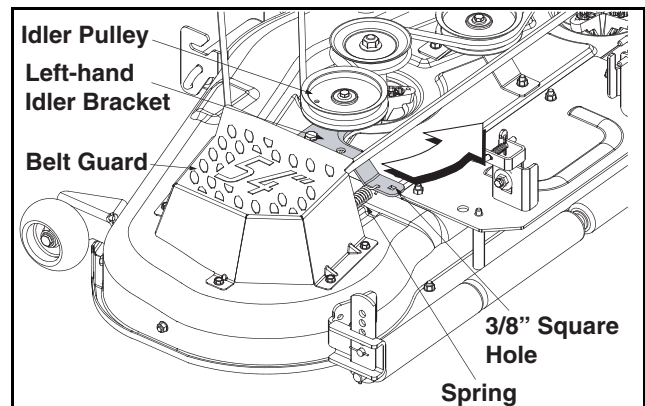
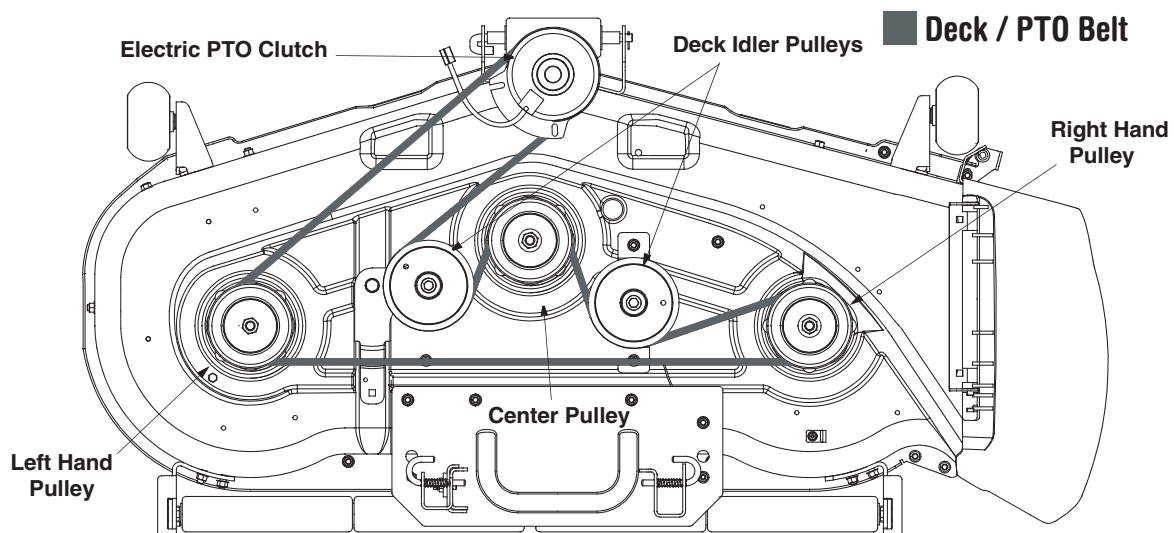

Figure 20



NOTE: Belt covers not shown for clarity.

Figure 21

- Grasp the ratchet's handle and pivot it toward the front of the tractor to relieve tension on the belt.
- With belt tension relieved, **carefully remove the belt from around the left-hand spindle pulley.**

IMPORTANT: Carefully allow the ratchet to pivot rearward before removing it from the square hole.

- Remove the deck belt from around all pulleys, including the deck idler pulley.
- Route the new belts (deck belt first). See Figure 21 **IMPORTANT:**
- Remount the belt guards removed earlier.

CHANGING THE TRANSMISSION DRIVE BELTS



WARNING: Be sure to shut the engine off, remove ignition key, disconnect the spark plug wire(s) and ground against the engine to prevent unintended starting before removing the belt(s). All belts on your tractor are subject to wear and should be replaced if any signs of wear are present.

All belts on your tractor are subject to wear and should be replaced if any signs of wear are present.

NOTE: It is recommended that both drive belts be replaced at the same time.

IMPORTANT: The V-belts found on your tractor are specially designed to engage and disengage safely. A substitute (non-OEM) V-belt can be dangerous by not disengaging completely. For a proper working machine, use factory approved belts.

To change or replace the drive belt on your tractor, proceed as follows:

- Remove the cutting deck as instructed earlier in this section.
- After disconnecting the battery cables, remove the battery and battery tray from beneath the seat.

NOTE: When removing the battery, disconnect the **NEGATIVE** (Black) wire from its terminal first, followed by the **POSITIVE** (Red) wire. Re-install in reverse order. Proper removal of the drive belt requires the removal of several tractor components. Read through the following procedure prior to attempting it to determine if you feel you could successfully complete it. If you don't, see your authorized dealer to have the belt changed.

IMPORTANT: Note the routing of the lower drive belt around all the pulleys and the belt keepers (if present) **BEFORE** performing the following steps.

Upper Drive Belt

Locate the transmission idler pulley on the upper drive belt by looking through the battery tray opening. See Figure 22.

- Grasp the bracket and pivot the transmission idler pulley toward the rear of the tractor to release tension on the upper drive belt.
- Remove the belt from around the transmission idler pulley.
- Remove the upper drive belt from around the transmission pulley and the variable-speed pulley.

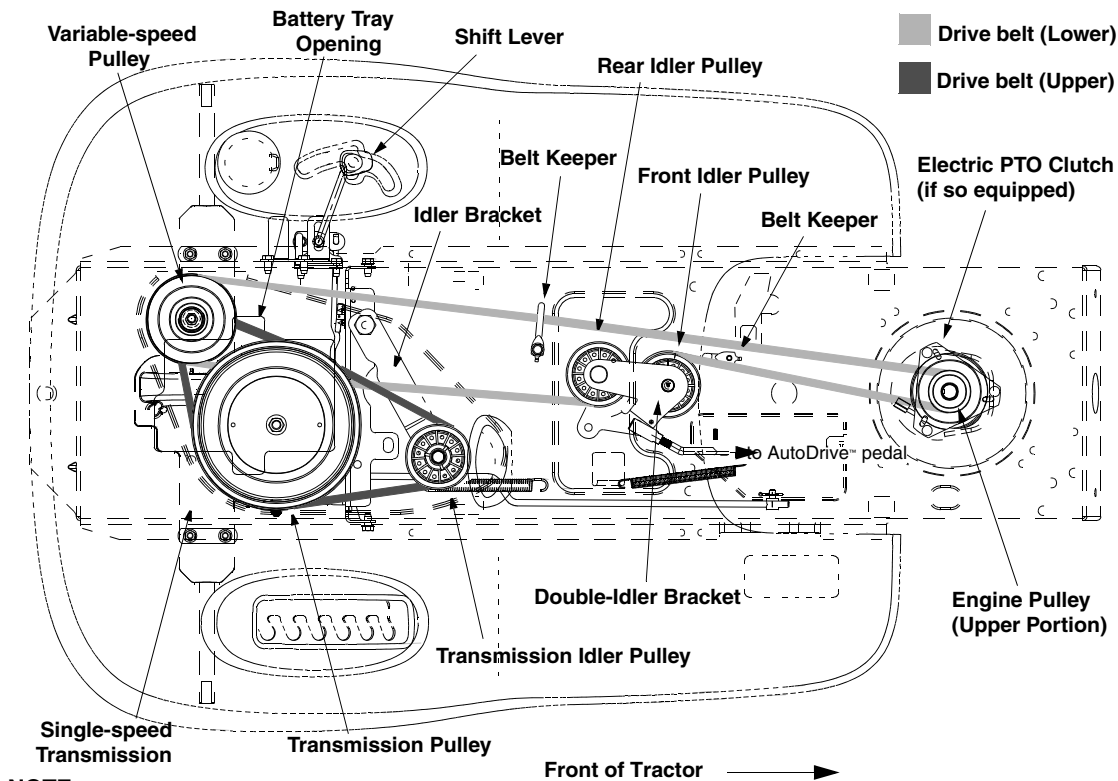

NOTE: View shown from above tractor.

Figure 22

NOTE: Slowly rotate the pulley counterclockwise to roll the belt off of it.

- Remove the upper drive belt by pulling it up through the battery tray opening.
- Reroute the new upper drive belt as shown in Figure 22.

Lower Drive Belt

IMPORTANT: Proper removal of the lower drive belt requires the removal of several tractor components. Read through the following procedure prior to attempting it to determine if you feel you could successfully complete it. If you don't, see an authorized service dealer to have the belt changed.

IMPORTANT: Note the routing of the lower drive belt around both the pulleys and the belt keepers BEFORE performing the following steps.

- Locate the variable-speed pulley through the battery tray opening. See Figure 22.
- Remove the variable-speed pulley by loosening the hex bolt that secures it to the transmission. Use a second wrench to hold the hex nut on the bottom side of the pulley.
- Slide the belt off the variable-speed pulley as you lift the pulley up and out through the battery tray opening.
- Remove rear idler pulley from the double-idler bracket while loosening the belt from around both the rear and the front idler pulleys. See Figure 22.
- Remove the hex bolt from the center of the engine pulley or the electric PTO clutch and gently lower it off the engine crankshaft. Be careful not to lose any washers or which may be found on top of the PTO clutch.

IMPORTANT: When remounting the PTO clutch, torque the center hex bolt to between 38 foot-pounds and 50 foot-pounds.

- Remove the drive belt by feeding it from both ends toward the front idler pulley on the double-idler bracket. See Figure 24.
- Reassemble by following the above steps in reverse order.
- Reroute the new belt around the pulleys, belt keepers and keeper pins exactly as the old one was routed. Refer to Figure 22.

The drive pedal is properly adjusted when the hole found

in the double-idler bracket has approximately 1-3/8" of travel with ten pounds of pressure applied to the drive pedal. See Figure 23.

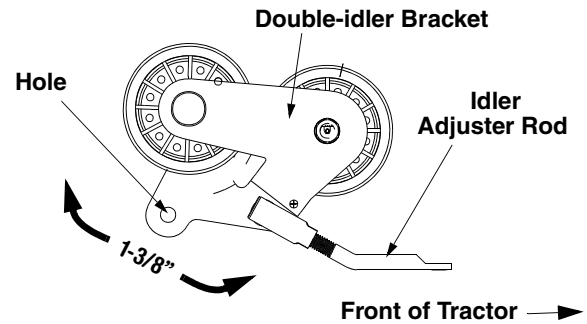

NOTE: View shown from above tractor.

Figure 23

Adjust the drive pedal after replacing the drive belts on your tractor, if necessary, as follows:

- Locate the speed control assembly on the underside of the steering support bracket. See Figure 24.
- Remove both hairpin clips from the pin which is fastened to the speed control assembly (be careful not to lose the small flat washers found on the pin). See Figure 24.
- Remove the drive pedal return spring.
- Using two 9/16" wrenches, remove the pin from the speed control assembly. See Figure 24.
- Thread the idler adjustment rod inward or outward to lengthen or shorten the travel of the double-idler bracket until proper adjustment is achieved.
- Reassemble by following the above steps in reverse order.

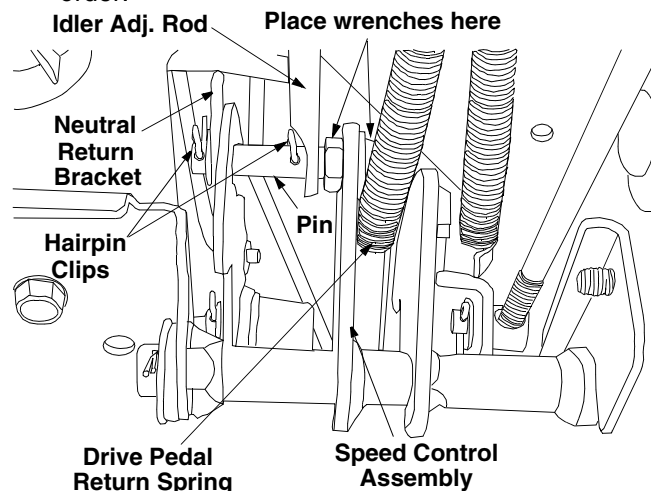

Figure 24

SECTION 11: OFF-SEASON STORAGE



WARNING: Never store the machine or fuel container indoors where there is an open flame, spark or pilot light such as on water heater, furnace, clothes dryer or other gas appliance.



WARNING: Use a fuel stabilizer additive or drain the fuel into an approved container outdoors, away from an open flame. Allow engine to cool. Extinguish cigarettes, cigars, pipes and other sources of ignition prior to draining fuel.

If the machine is to be inoperative for a period longer than 30 days, prepare for storage as follows.

- Clean the engine and the entire unit thoroughly.
- Lubricate all lubrication points. Wipe the entire machine with an oiled rag to protect the painted metal surfaces.
- Refer to the engine manual for correct engine storage instructions. The engine must be completely drained of fuel to prevent gum deposits from forming on essential carburetor parts, fuel lines and fuel tanks.
- It is not necessary to remove the battery from the tractor for storage. However, clean the top of the battery and make sure it has full charge.

Disconnect the negative terminal of the battery before storing the tractor.

- Store unit in a clean, dry area.

NOTE: When storing any type of power equipment in an unventilated or metal storage shed, care should be taken to rustproof the equipment. Using a light oil or silicone, coat the equipment, especially any chains, springs, bearings and cables.

NOTE: Recharge the battery before returning it to service after storage. Even if the tractor starts, the engine charging system may not bring the battery up to a full charge, unless it is recharged.

SECTION 12: TROUBLESHOOTING

Trouble	Possible Cause(s)	Corrective Action
Engine fails to start	PTO lever engaged. Parking brake not engaged. Spark plug wire(s) disconnected. Throttle control not in correct position Choke not activated. Fuel tank empty, or stale fuel. Blocked fuel line. Faulty spark plug. Engine flooded.	Place PTO lever in disengaged (Blade Stop) position. Engage parking brake. Connect wire(s) to spark plug. Place throttle lever to fast or choke (if so equipped). Activate choke. Fill tank with clean, fresh (less than 30 days old) gas. Clean fuel line or replace fuel filter, if so equipped. Clean, adjust gap or replace plug. Crank engine with throttle in FAST position.
Engine runs erratic	Unit running with CHOKE applied. Spark plug wire loose. Blocked fuel line or stale fuel. Vent in gas cap plugged. Water or dirt in fuel system. Dirty air cleaner.	Place throttle lever in FAST position. Connect and tighten spark plug wire. Clean fuel line; fill tank with clean, fresh (less than 30 days old) gasoline. Replace fuel filter, if so equipped. Clear vent or replace cap if damaged. Drain fuel tank. Refill with clean, fresh (less than 30 days old) gasoline. Replace air cleaner cartridge/element or clean pre-cleaner, if so equipped.
Engine overheats	Engine oil level low. Air flow restricted.	Fill crankcase with proper capacity and weight of oil. Clean grass clippings and debris from around the engine's cooling fins and blower housing.
Engine hesitates at high RPM	Spark plug gap too close.	Remove spark plug and reset the gap to .030".
Idles poorly	Spark plug fouled, faulty or gap too wide. Dirty air cleaner.	Replace spark plug. Set plug gap to .030". Replace air cleaner cartridge/element or clean pre-cleaner, if so equipped.
Excessive vibration	Cutting blade loose or unbalanced or damaged.	Tighten blade and spindle. Balance blade. Replace blade.
Mower will not mulch grass	Engine speed low. Wet grass. Excessively high grass. Dull blade.	Place throttle in FAST position. Do not mow when grass is wet; wait until later to cut. Mow once at a higher cutting height, then mow again at desired height or make a narrower cutting swath. Sharpen or replace blade.
Uneven cut	Deck not balanced properly. Dull blade. Uneven tire pressure.	Perform side-to-side deck adjustment. Sharpen or replace blade. Check tire pressure in all four tires.

Free Manuals Download Website

<http://myh66.com>

<http://usermanuals.us>

<http://www.somanuals.com>

<http://www.4manuals.cc>

<http://www.manual-lib.com>

<http://www.404manual.com>

<http://www.luxmanual.com>

<http://aubethermostatmanual.com>

Golf course search by state

<http://golfingnear.com>

Email search by domain

<http://emailbydomain.com>

Auto manuals search

<http://auto.somanuals.com>

TV manuals search

<http://tv.somanuals.com>