

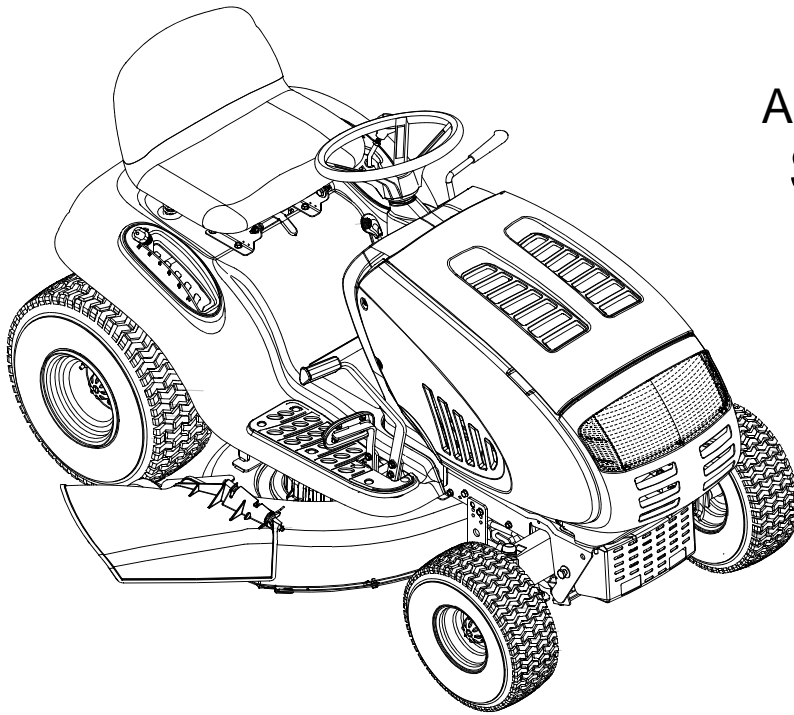

Operator's Manual



Auto Drive Lawn Tractors
Super Bronco™
Bronco™
(Models J609 & T609)

IMPORTANT: Read safety rules and instructions carefully before operating equipment.

Warning: This unit is equipped with an internal combustion engine and should not be used on or near any unimproved forest-covered, brush-covered or grass-covered land unless the engine's exhaust system is equipped with a spark arrester meeting applicable local or state laws (if any). If a spark arrester is used, it should be maintained in effective working order by the operator. In the State of California the above is required by law (Section 4442 of the California Public Resources Code). Other states may have similar laws. Federal laws apply on federal lands. A spark arrester for the muffler is available through your nearest engine authorized service dealer or contact the service department, P.O. Box 361131 Cleveland, Ohio 44136-0019.

TROY-BILT LLC. P.O. BOX 361131, CLEVELAND, OHIO 44136-0019

PRINTED IN U.S.A.

FORM NO. 770-10490D
(4/2004)

TABLE OF CONTENTS

Content	Page	Content	Page
Customer Support	2	Service	17
Important Safe Operation Practices	3	Off-Season Storage	22
Tractor Set-Up	7	Attachments & Accessories	22
Operation	8	Troubleshooting	23
Making Adjustments	13	Illustrated Parts List	24
Maintenance	15	Warranty	40

FINDING MODEL NUMBER

This Operator's Manual is an important part of your new lawn tractor. It will help you assemble, prepare and maintain the unit for best performance. Please read and understand what it says.



Before you start assembling your new equipment, please locate the model plate under the seat of the tractor and copy the information in the space provided below. A sample model plate is also given below. This information will be necessary to use the manufacturer's web site and/or help from the Customer Support Department or an authorized service dealer.

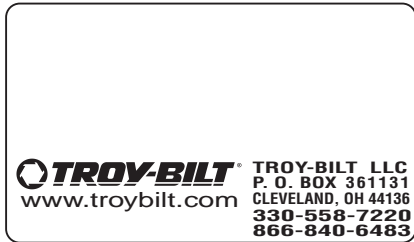

Copy the model number here: _____

Copy the serial number here: _____

CUSTOMER SUPPORT

Please do NOT return the unit to the retailer from where it was purchased, without first contacting Customer Support.

If you have difficulty assembling this product or have any questions regarding the controls, operation or maintenance of this unit, you can seek help from the experts. Choose from the options below:

	<p>Visit troybilt.com for many useful suggestions. Click on Customer Support button and you will get the four options reproduced here. Click on the appropriate button and help is immediately available.</p> <div style="text-align: center; margin: 20px 0;"> </div> <div style="display: flex; justify-content: space-between;"> <div style="width: 45%; text-align: center; color: gray; font-style: italic;"> <p><i>The answer you are looking for could be just a mouse click away!</i></p> </div> <div style="width: 45%; text-align: center; color: gray; font-style: italic;"> <p><i>The answer you are looking for could be just a mouse click away!</i></p> </div> </div>
	<p>To reach the Customer Support Line, please call 1-866-840-6483 or 1-330-558-7220.</p>
	<p>The engine manufacturer is responsible for all engine-related issues with regards to performance, power-rating, specifications, warranty and service. Please refer to the engine manufacturer's Owner's/Operator's Manual, at the end of this manual, for more information.</p>

SECTION 1: IMPORTANT SAFE OPERATION PRACTICES



WARNING: This symbol points out important safety instructions which, if not followed, could endanger the personal safety and/or property of yourself and others. Read and follow all instructions in this manual before attempting to operate this machine. Failure to comply with these instructions may result in personal injury. When you see this symbol—heed its warning.

DANGER: This machine was built to be operated according to the rules for safe operation in this manual. As with any type of power equipment, carelessness or error on the part of the operator can result in serious injury. This machine is capable of amputating hands and feet and throwing objects. Failure to observe the following safety instructions could result in serious injury or death.

California Proposition 65 Warning: Engine exhaust, some of its constituents, and certain vehicle components contain or emit chemicals known to the State of California to cause cancer and birth defects or other reproductive harm.

General Operation

1. Read, understand, and follow all instructions on the machine and in the manual(s) before attempting to assemble and operate. Keep this manual in a safe place for future and regular reference and for ordering replacement parts.
2. Be familiar with all controls and their proper operation. Know how to stop the machine and disengage them quickly.
3. Never allow children under 14 years old to operate this machine. Children 14 years old and over should read and understand the operation instructions and safety rules in this manual and should be trained and supervised by a parent.
4. Never allow adults to operate this machine without proper instruction.
5. To help avoid blade contact or a thrown object injury, keep bystanders, helpers, children and pets at least 75 feet from the machine while it is in operation. Stop machine if anyone enters the area.
6. Thoroughly inspect the area where the equipment is to be used. Remove all stones, sticks, wire, bones, toys, and other foreign objects which could be picked up and thrown by the blade(s). Thrown objects can cause serious personal injury.
7. Plan your mowing pattern to avoid discharge of material toward roads, sidewalks, bystanders and the like. Also, avoid discharging material against a wall or obstruction which may cause discharged material to ricochet back toward the operator.
8. Always wear safety glasses or safety goggles during operation and while performing an adjustment or repair to protect your eyes. Thrown objects which ricochet can cause serious injury to the eyes.
9. Wear sturdy, rough-soled work shoes and close-fitting slacks and shirts. Loose fitting clothes and jewelry can be caught in movable parts. Never operate this machine in bare feet or sandals.
10. Be aware of the mower and attachment discharge direction and do not point it at anyone. Do not operate the mower without the discharge cover or entire grass catcher in its proper place.
11. Do not put hands or feet near rotating parts or under the cutting deck. Contact with the blade(s) can amputate hands and feet.
12. A missing or damaged discharge cover can cause blade contact or thrown object injuries.
13. Stop the blade(s) when crossing gravel drives, walks, or roads and while not cutting grass.
14. Watch for traffic when operating near or crossing roadways. This machine is not intended for use on any public roadway.
15. Do not operate the machine while under the influence of alcohol or drugs.
16. Mow only in daylight or good artificial light.
17. Never carry passengers.
18. Disengage blade(s) before shifting into reverse. Back up slowly. Always look down and behind before and while backing to avoid a back-over accident.
19. Slow down before turning. Operate the machine smoothly. Avoid erratic operation and excessive speed.
20. Disengage blade(s), set parking brake, stop engine and wait until the blade(s) come to a complete stop before removing grass catcher, emptying grass, unclogging chute, removing any grass or debris, or making any adjustments.
21. Never leave a running machine unattended. Always turn off blade(s), place transmission in neutral, set parking brake, stop engine and remove key before dismounting.
22. Use extra care when loading or unloading the machine into a trailer or truck. This unit should not be driven up or down ramp(s), because the unit could tip over, causing serious personal injury. The unit must be pushed manually on ramp(s) to load or unload properly.
23. Muffler and engine become hot and can cause a burn. Do not touch.
24. Check overhead clearances carefully before driving under low hanging tree branches, wires, door openings etc., where the operator may be struck or pulled from the unit, which could result in serious injury.
25. Disengage all attachment clutches, depress the brake pedal completely and shift into neutral before attempting to start engine.
26. Your machine is designed to cut normal residential grass of a height no more than 10". Do not attempt to mow through unusually tall, dry grass (e.g., pasture) or piles of dry leaves. Dry grass or leaves may contact the engine exhaust and/or build up on the mower deck presenting a potential fire hazard.

27. Use only accessories and attachments approved for this machine by the machine manufacturer. Read, understand and follow all instructions provided with the approved accessory or attachment.
28. Data indicates that operators, age 60 years and above, are involved in a large percentage of riding mower-related injuries. These operators should evaluate their ability to operate the riding mower safely enough to protect themselves and others from serious injury.
29. If situations occur which are not covered in this manual, use care and good judgment. Contact your *Troy-Bilt* dealer for assistance.

Slope Operation

Slopes are a major factor related to loss of control and tip-over accidents which can result in severe injury or death. All slopes require extra caution. If you cannot back up the slope or if you feel uneasy on it, do not mow it.

For your safety, use the slope gauge included as part of this manual to measure slopes before operating this unit on a sloped or hilly area. If the slope is greater than 15 degrees as shown on the slope gauge, do not operate this unit on that area or serious injury could result.

Do:

1. Mow up and down slopes, not across. Exercise extreme caution when changing direction on slopes.
2. Watch for holes, ruts, bumps, rocks, or other hidden objects. Uneven terrain could overturn the machine. Tall grass can hide obstacles.
3. Use slow speed. Choose a low enough speed setting so that you will not have to stop or shift while on the slope. Tires may lose traction on slopes even though the brakes are functioning properly. Always keep machine in gear when going down slopes to take advantage of engine braking action.
4. Follow the manufacturer's recommendations for wheel weights or counterweights to improve stability.
5. Use extra care with grass catchers or other attachments. These can change the stability of the machine.
6. Keep all movement on the slopes slow and gradual. Do not make sudden changes in speed or direction. Rapid engagement or braking could cause the front of the machine to lift and rapidly flip over backwards which could cause serious injury.
7. Avoid starting or stopping on a slope. If tires lose traction, disengage the blade(s) and proceed slowly straight down the slope.

Do Not:

1. Do not turn on slopes unless necessary; then, turn slowly and gradually downhill, if possible.
2. Do not mow near drop-offs, ditches or embankments. The mower could suddenly turn over if a wheel is over the edge of a cliff, ditch, or if an edge caves in.
3. Do not try to stabilize the machine by putting your foot on the ground.
4. Do not use a grass catcher on steep slopes.
5. Do not mow on wet grass. Reduced traction could cause sliding.
6. Do not shift to neutral and coast downhill. Over-speeding may cause the operator to lose control of the machine resulting in serious injury or death.

7. Do not tow heavy pull behind attachments (e.g. loaded dump cart, lawn roller, etc.) on slopes greater than 5 degrees. When going down hill, the extra weight tends to push the tractor and may cause you to lose control. (e.g. tractor may speed up, braking and steering ability are reduced, attachment may jack-knife and cause tractor to overturn).

Children

1. Tragic accidents can occur if the operator is not alert to the presence of children. Children are often attracted to the machine and the mowing activity. They do not understand the dangers. Never assume that children will remain where you last saw them.
 - a. Keep children out of the mowing area and in watchful care of a responsible adult other than the operator.
 - b. Be alert and turn machine off if a child enters the area.
 - c. Before and while backing, look behind and down for small children.
 - d. Never carry children, even with the blade(s) shut off. They may fall off and be seriously injured or interfere with safe machine operation.
 - e. Use extreme care when approaching blind corners, doorways, shrubs, trees or other objects that may block your vision of a child who may run into the machine.
 - f. Disengage the cutting blade(s) before shifting in reverse. The "No-Cut-In Reverse" feature is a reminder not to cut in reverse and to help avoid back over accidents. Do not defeat it.
 - g. Keep children away from hot or running engines. They can suffer burns from a hot muffler.
 - h. Remove key when machine is unattended to prevent unauthorized operation.
2. Never allow children under 14 years old to operate the machine. Children 14 years old and over should read and understand the operation instructions and safety rules in this manual and should be trained and supervised by a parent.

Towing

1. Tow only with a machine that has a hitch designed for towing. Do not attach towed equipment except at the hitch point.
2. Follow the manufacturer's recommendation for weight limits for towed equipment and towing on slopes.
3. Never allow children or others in or on towed equipment.
4. On slopes, the weight of the towed equipment may cause loss of traction and loss of control.
5. Travel slowly and allow extra distance to stop.
6. Do not shift to neutral and coast downhill.

Service

Gasoline:

1. **To avoid personal injury or property damage** use extreme care in handling gasoline. **Gasoline is** extremely flammable and the vapors are explosive. Serious personal injury can occur when gasoline is spilled on yourself or your clothes which can ignite. Wash your skin and change clothes immediately.
 - a. Use only an approved gasoline container.

- b. Never fill containers inside a vehicle or on a truck or trailer bed with a plastic liner. Always place containers on the ground away from your vehicle before filling.
- c. When practical, remove gas-powered equipment from the truck or trailer and refuel it on the ground. If this is not possible, then refuel such equipment on a trailer with a portable container, rather than from a gasoline dispenser nozzle.
- d. Keep the nozzle in contact with the rim of the fuel tank or container opening at all times until fueling is complete. Do not use a nozzle lock-open device.
- e. Extinguish all cigarettes, cigars, pipes and other sources of ignition.
- f. Never fuel machine indoors.
- g. Never remove gas cap or add fuel while the engine is hot or running. Allow engine to cool at least two minutes before refueling.
- h. Never over fill fuel tank. Fill tank to no more than ½ inch below bottom of filler neck to allow space for fuel expansion.
- i. Replace gasoline cap and tighten securely.
- j. If gasoline is spilled, wipe it off the engine and equipment. Move unit to another area. Wait 5 minutes before starting the engine.
- k. To reduce fire hazards, keep machine free of grass, leaves, or other debris build-up. Clean up oil or fuel spillage and remove any fuel soaked debris.
- l. Never store the machine or fuel container inside where there is an open flame, spark or pilot light as on a water heater, space heater, furnace, clothes dryer or other gas appliances.
- m. Allow a machine to cool at least 5 minutes before storing.

General:

- 1. Never run an engine indoors or in a poorly ventilated area. Engine exhaust contains carbon monoxide, an odorless, and deadly gas.
- 2. Before cleaning, repairing, or inspecting, make certain the blade(s) and all moving parts have stopped. Disconnect the spark plug wire and ground against the engine to prevent unintended starting.
- 3. Periodically check to make sure the blades come to complete stop within approximately (5) five seconds after operating the blade disengagement control. If the blades do not stop within the this time frame, your unit should be

- 4. serviced professionally by your *Troy-Bilt* dealer.
- 4. Check brake operation frequently as it is subjected to wear during normal operation. Adjust and service as required.
- 5. Check the blade(s) and engine mounting bolts at frequent intervals for proper tightness. Also, visually inspect blade(s) for damage (e.g., excessive wear, bent, cracked).
Replace the blade(s) with the original equipment manufacturer's (O.E.M.) blade(s) only, listed in this manual. "Use of parts which do not meet the original equipment specifications may lead to improper performance and compromise safety!"
- 6. Mower blades are sharp. Wrap the blade or wear gloves, and use extra caution when servicing them.
- 7. Keep all nuts, bolts, and screws tight to be sure the equipment is in safe working condition.
- 8. Never tamper with the safety interlock system or other safety devices. Check their proper operation regularly.
- 9. After striking a foreign object, stop the engine, disconnect the spark plug wire(s) and ground against the engine. Thoroughly inspect the machine for any damage. Repair the damage before starting and operating.
- 10. Never attempt to make adjustments or repairs to the machine while the engine is running.
- 11. Grass catcher components and the discharge cover are subject to wear and damage which could expose moving parts or allow objects to be thrown.
For safety protection, frequently check components and replace immediately with original equipment manufacturer's (O.E.M.) parts only, listed in this manual. "Use of parts which do not meet the original equipment specifications may lead to improper performance and compromise safety!"
- 12. Do not change the engine governor settings or over-speed the engine. The governor controls the maximum safe operating speed of the engine.
- 13. Maintain or replace safety and instruction labels, as necessary.
- 14. Observe proper disposal laws and regulations for gas, oil, etc. to protect the environment.

Your Responsibility

Restrict the use of this power machine to persons who read, understand and follow the warnings and instructions in this manual and on the machine.

SECTION 2: SLOPE GAUGE

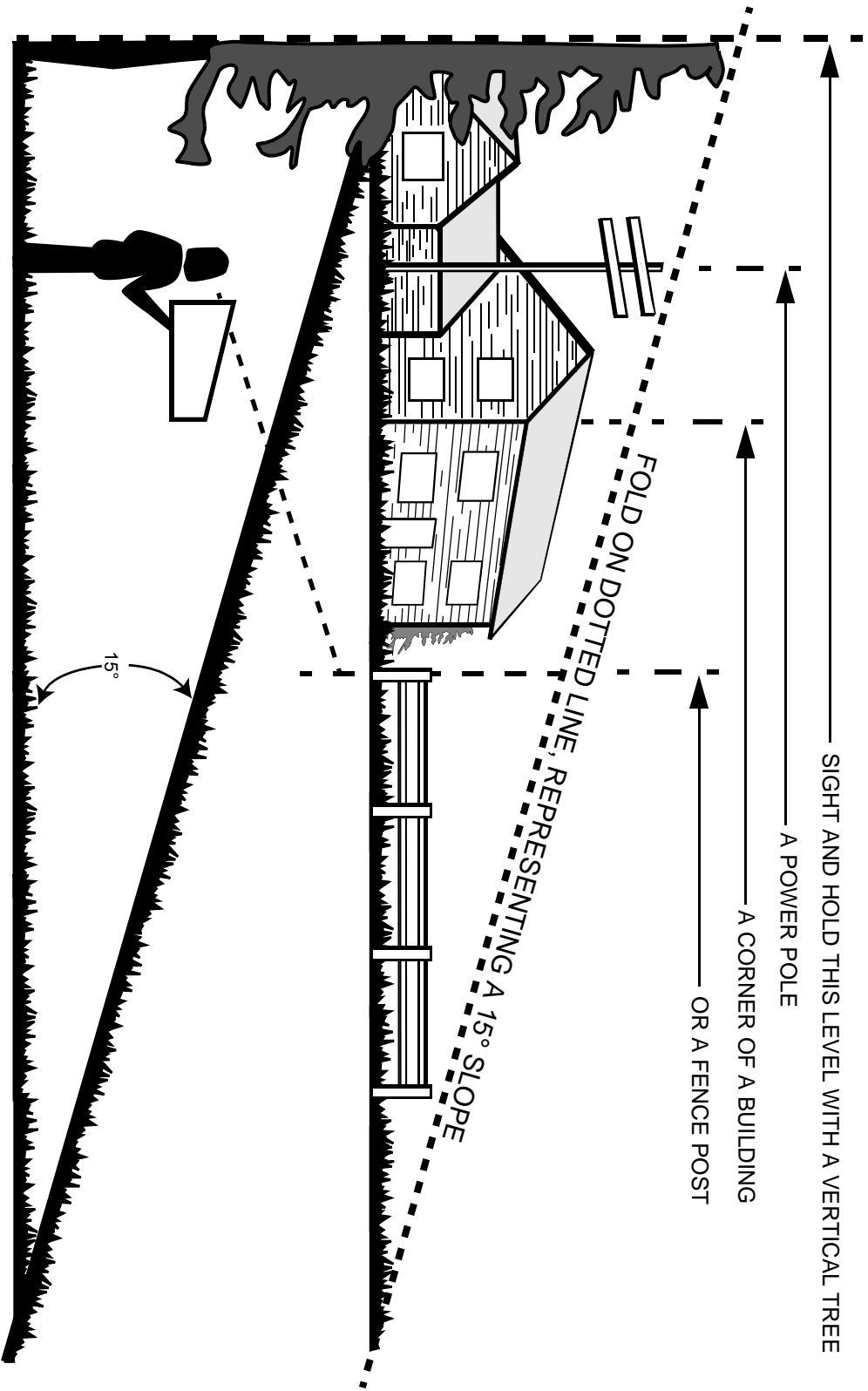

Do not mow on inclines with a slope in excess of 15 degrees (a rise of approximately 2-1/2 feet every 10 feet). A riding mower could overturn and cause serious injury. If operating a walk-behind mower on such a slope, it is extremely difficult to maintain your footing and you could slip, resulting in serious injury. Operate RIDING mowers up and down slopes, never across the face of slopes.

SECTION 3: TRACTOR SET-UP

NOTE: Any reference to right, left, front or back of the tractor is from the operating position, unless otherwise stated.

Attaching The Steering Wheel

- The hardware for attaching the steering wheel has been packed within the steering wheel, beneath steering wheel cap. Carefully pry off the steering wheel cap and remove the hardware.
- **With the wheels of the tractor pointing straight forward**, place steering wheel over steering shaft.
- Place the washer (with the cupped side down) over the steering shaft and secure with the hex bolt. See Figure 2.
- Place steering wheel cap over the center of steering wheel and push downward until it “clicks” into place.

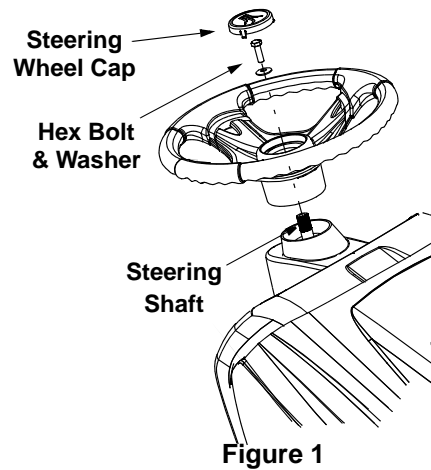

Figure 1

Attaching The Seat

NOTE: For shipping reasons, seats are mounted backward to the pivot bracket. Release the seat from its shipping position and remove the two **hex** screws from the bottom of the seat before proceeding.

- Pull out the tab found on the seat stop and hold it open while sliding the seat off the seat pivot bracket. See Figure 3.
- Line up the plastic seat spacers with the slots in seat pivot bracket.
- Slide seat in until front seat spacer engages the seat stop. See Figure 3.

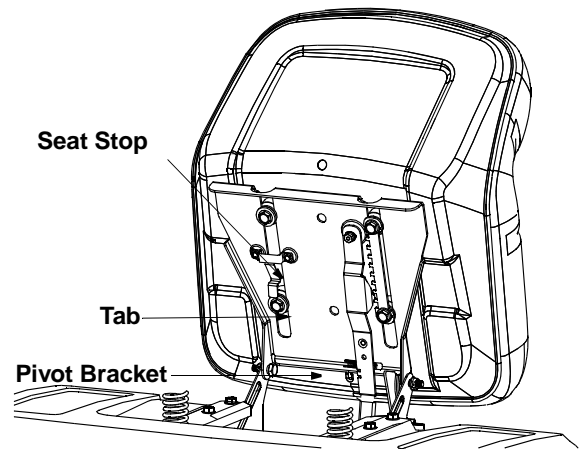

Figure 2



WARNING: Before operating, stand behind the machine and pull back on seat until fully engaged into stop.

Remove Shipping Brace

IMPORTANT: The shipping brace must be removed and discarded before operating your riding mower.

- Locate the shipping brace and accompanying warning tag on the right side of the mower, between discharge chute and cutting deck. See Figure 3.
- While holding the discharge chute up, rotate the shipping brace clockwise and remove.
- Discard the shipping brace.

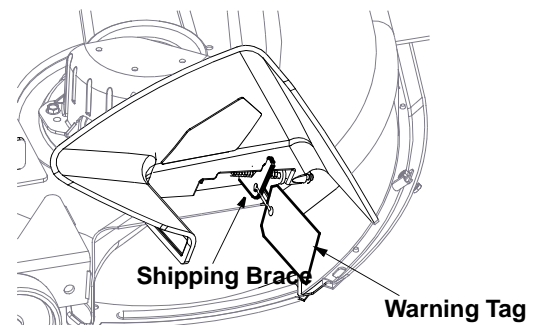

Figure 3

Gas and Oil Fill-Up

The gasoline tank is located under the hood and depending on the model of tractor, has a capacity of either two or three gallons. Do not overfill.



WARNING: Use extreme care when handling gasoline. Gasoline is extremely flammable and the vapors are explosive. Never fuel machine indoors or while the engine is hot or running. Extinguish cigarettes, cigars, pipes, and other sources of ignition.

IMPORTANT: Your tractor is shipped with motor oil in the engine. However, you **MUST** check the oil level before operating. The capacity of your engine's sump and oil filter is 62 oz (1.8 liters). Be careful not to overfill.

SECTION 4: OPERATION

Know the Controls

Read this owner's manual and safety rules before operating your lawn mower. Compare figure below with your lawn tractor to learn about the location and purpose of various controls and adjustments. Save this manual for future reference. It is very important to follow the instructions and operate the controls properly.

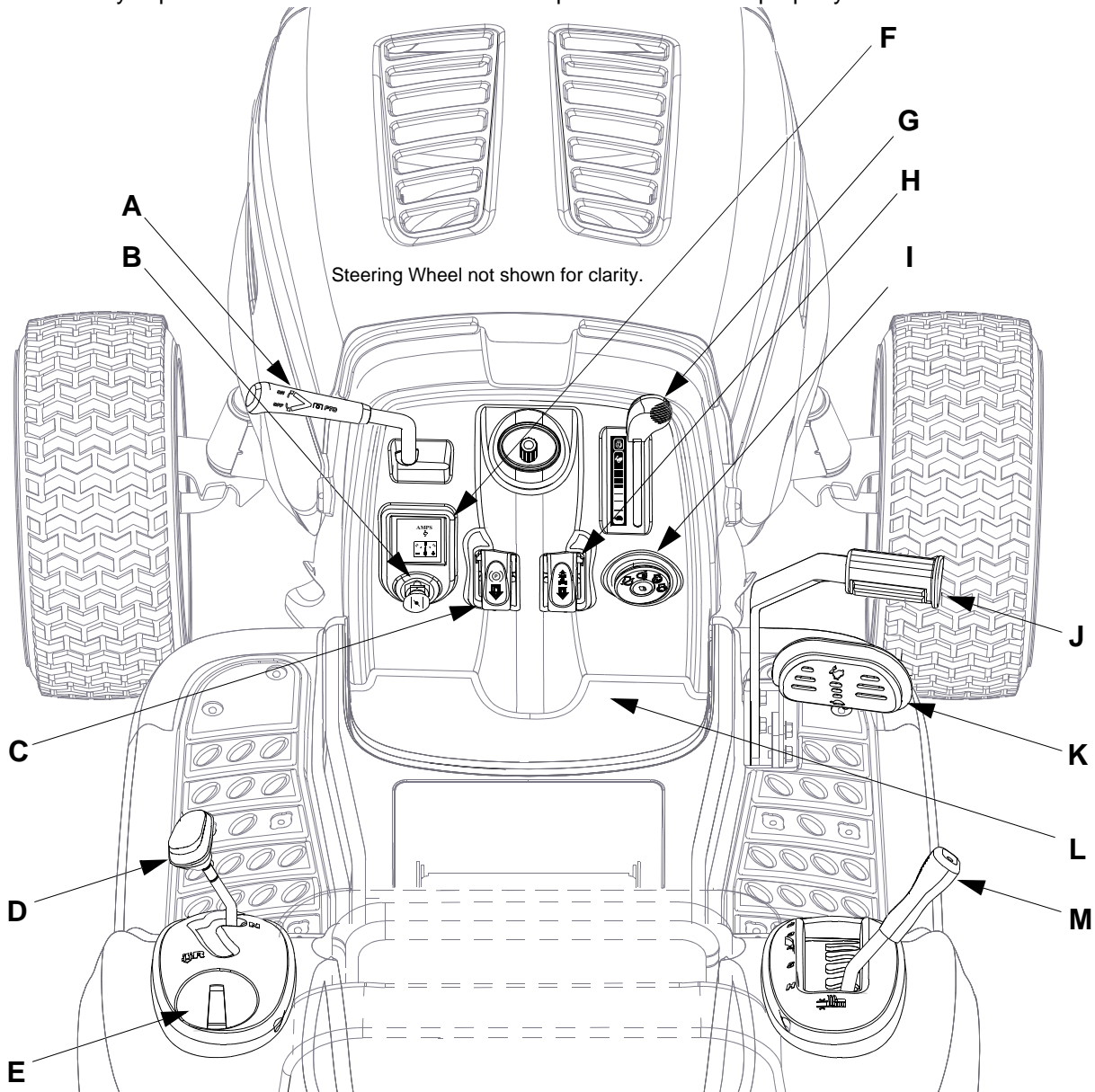

Figure 4

- | | | | |
|---|-----------------------------------|---|-----------------------|
| A | PTO (Blade Engage) Lever | H | Cruise Control Button |
| B | Choke Control (Super Bronco only) | I | Ignition Switch |
| C | Parking Brake Button | J | Brake Pedal |
| D | Shift Lever | K | Drive Pedal |
| E | Cup Holder | L | Cargo Net (not shown) |
| F | Ammeter | M | Deck Lift Lever |
| G | Throttle Control Lever | | |

NOTE: Any reference in this manual to the RIGHT or LEFT side of the tractor is observed from operator's position.

Throttle Control Lever

The throttle control lever controls the speed of the engine. When set in a given position, the throttle will maintain a uniform engine speed.

Choke Control

Bronco: Moving the throttle lever all the way forward activates the engine's choke control.

Super Bronco: The choke control knob is on the left side of the dash panel and is activated by pulling outward. Activating the choke control closes the choke plate on the carburetor and aids in starting the engine.

IMPORTANT: When operating the tractor with the cutting deck engaged, throttle control lever must **always be** in the FAST (rabbit) position.

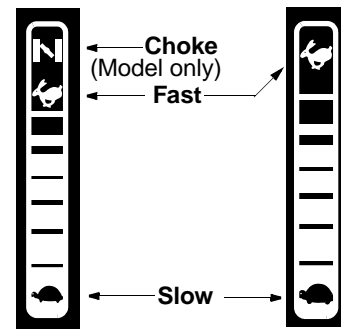

Brake Pedal

The brake pedal is used for sudden stops or setting the parking brake. This pedal must be fully depressed to activate the safety interlock switch when starting the tractor.

Parking Brake Button

NOTE: The parking brake must be set if the operator leaves the seat with the engine running; otherwise the engine will automatically shut off.



- To set the parking brake, fully depress the brake pedal and push the parking brake button in. Hold the button in while taking your foot off the brake pedal. Both parking button and brake pedal will stay depressed.
- To release the parking brake, depress the brake pedal slightly. The parking brake button will then return to its original position.

IMPORTANT: Always set the parking brake when leaving the tractor unattended.

Drive Pedal

The drive pedal controls movement and ground speed of the tractor. Depress the drive pedal with your right foot (when the tractor shift lever is in either forward or reverse) to cause the tractor to move. The further down the pedal is depressed, the faster the tractor will travel. The pedal will return to its original position when it is not depressed.

PTO (Blade Engage) Lever

Engaging this lever transfers power to the cutting deck or other (separately available) attachments. The PTO (Blade Engage) lever **must** be disengaged when (1) starting the engine, (2) travelling in reverse or (3) if the operator leaves the seat.

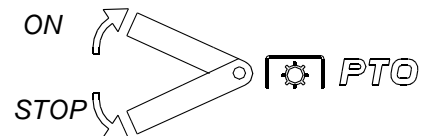

* This may also be referred to as simply PTO lever.

- To engage the PTO, proceed as follows:
 1. Move the throttle control lever to the FAST (rabbit) position.
 2. Grasp the PTO (Blade Engage) lever and pivot it all the way forward into the engaged (ON) position.
 3. Keep the throttle lever in the FAST (rabbit) position for the most efficient use of the cutting deck or other (separately available) attachments.
- To disengage the PTO, move the lever towards rear. This will cut off power to deck or other attachments.

IMPORTANT: The engine will automatically shut off if (1) the operator leaves the seat while the PTO is still engaged regardless of whether the parking brake is engaged, and (2) the PTO is engaged while the drive pedal is in position for reverse travel.

Ignition Switch

Ignition switch is activated to start the engine. Insert key into the ignition switch and turn clockwise to the START position. Release the key into the ON position once engine has fired.



WARNING: Never leave a running machine unattended. Always disengage PTO, move shift lever into neutral position, set parking brake, stop engine and remove key to prevent unintended starting.

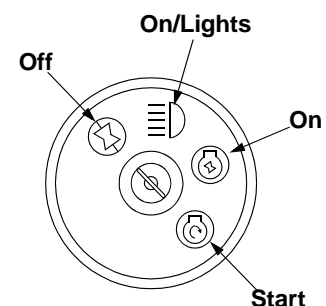

Headlights

- To turn on the headlights, rotate the same ignition key from ON position to ON/LIGHTS position of the ignition switch.
- To turn off the headlights, rotate the ignition key from ON/LIGHTS position to either ON position (to leave the engine running) or OFF position (to shut the engine off).



WARNING: Never move the key into the Start position while the engine is running. Doing so may cause damage to your engine's starter.

Ammeter

The ammeter measures the electrical output of the engine's charging system. Under normal operating conditions, with engine at full throttle, the ammeter should indicate positive charge.

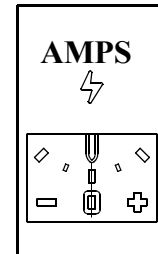

Shift Lever

The shift lever has three positions: FORWARD (F), NEUTRAL (N) and REVERSE (R). These control the direction of movement of the tractor. Depress the brake pedal and let the tractor stop before moving the shift lever to one of these three positions.

IMPORTANT: Never force the shift lever. Doing so may result in serious damage to the tractor's transmission.

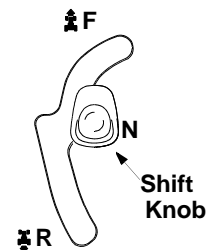

Cruise Control Button

The cruise control feature should only be utilized while traveling in the forward direction. To engage the cruise control, follow these steps:

1. Place shift lever in FORWARD position, then slowly depress the drive pedal until desired speed is achieved.
2. Lightly depress the cruise control button.
3. While continuing to hold the cruise button in, lift your foot from the drive pedal (you should feel the cruise latch engage).
4. Once engaged, the cruise control button and the drive pedal will lock in the "down" position, and the tractor will maintain same forward speed.

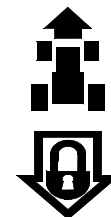

NOTE: *Cruise control cannot be engaged at the tractor's fastest ground speed. If the operator should attempt to do so, the tractor will automatically decelerate to the fastest optimal mowing ground speed.*

- To disengage the cruise control, lightly depress either the brake pedal or the drive pedal.
- To change to the reverse direction when operating with cruise control, depress the brake pedal to disengage the cruise control and bring the tractor to a complete stop. Then place the shift lever in the REVERSE position and depress the drive pedal.

Seat Adjustment Lever

To adjust the seat position, loosen the two seat adjustment knobs and reposition the seat to the desired position. Once a comfortable position is found, tighten the adjustment knobs to lock the seat in place.

Deck Lift Lever

The deck lift lever is used to change the height of the cutting deck. To use, move the lever to the left, then place it in one of the six notches best suited for your application.

To set the cutting height of the deck you will also have to adjust the deck wheels so that they are between ¼-inch and ½-inch above the ground when the tractor is on a smooth, flat surface such as a driveway. refer to Deck Levelling instructions on page 14.

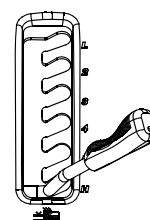

NOTE: The deck wheels are an anti-scalp feature of the deck and are not designed to support the weight of the cutting deck.

Cargo Net

Conveniently located on the tractor's dash panel, the cargo net can be used to store personal items while operating the lawn tractor.

Cup Holder

The tractor's cup holder is located on the fender to the left of the seat, just to the rear of the parking brake lever.

Safety Interlock Switches

The safety interlock system prevents the engine from cranking or starting unless the parking brake is engaged, and the PTO lever is in the "Blades Stop" position. If this system should ever malfunction, do not operate the tractor, immediately contact a *Troy-Bilt* dealer.

- The safety interlock system will automatically shut off the engine if the operator leaves the seat before engaging the parking brake.
- The safety interlock system will automatically shut off the engine if the operator leaves the tractor's seat with the PTO (Blade Engage) lever in the ON position, regardless of whether the parking brake is engaged.
- The safety interlock system will automatically shut off the engine if the PTO (Blade Engage) Lever is moved into the engaged (ON) position with the drive pedal in position for reverse travel.

IMPORTANT: Tampering with or attempting to bypass the tractors Safety Interlock Switches in any way will void your tractor's warranty.

**WARNING**

AVOID SERIOUS INJURY OR DEATH

- GO UP AND DOWN SLOPES, NOT ACROSS.
- AVOID SUDDEN TURNS.
- DO NOT OPERATE THE UNIT WHERE IT COULD SLIP OR TIP.
- IF MACHINE STOPS GOING UPHILL, STOP BLADE(S) AND BACK DOWNHILL SLOWLY.
- DO NOT MOW WHEN CHILDREN OR OTHERS ARE AROUND.
- NEVER CARRY CHILDREN, EVEN WITH BLADES OFF.
- LOOK DOWN AND BEHIND BEFORE AND WHILE BACKING.
- KEEP SAFETY DEVICES (GUARDS, SHIELDS, AND SWITCHES) IN PLACE AND WORKING.
- REMOVE OBJECTS THAT COULD BE THROWN BY THE BLADE(S).
- KNOW LOCATION AND FUNCTION OF ALL CONTROLS.
- BE SURE BLADE(S) AND ENGINE ARE STOPPED BEFORE PLACING HANDS OR FEET NEAR BLADE(S).
- BEFORE LEAVING OPERATOR'S POSITION, DISENGAGE BLADE(S), PLACE THE SHIFT LEVER IN NEUTRAL, ENGAGE BRAKE LOCK, SHUT ENGINE OFF AND REMOVE KEY.

READ OPERATOR'S MANUAL



WARNING: Do not operate the tractor if the interlock system is malfunctioning. This system was designed for your safety and protection.

Starting the Engine

NOTE: Refer to the **TRACTOR SET-UP** on page 7 manual for gasoline and oil fill-up instructions.

1. Insert the tractor key into the ignition switch.
2. Place the PTO (Blade Engage) Lever in the disengaged (Blade Stop) position.
3. Engage the tractor's parking brake.
4. Move the throttle control lever into the **CHOKER** position (a warm engine may not require choking).
5. Turn the ignition key clockwise to the **START** position. After the engine starts, release the key. It will return to the **ON** position.

IMPORTANT: Do **not** hold the key in the **START** position for longer than ten seconds at a time. Doing so may cause damage to your engine's electric starter.

6. After the engine starts, move the throttle control lever from **CHOKER** to the **FAST** position.

NOTE: Do **NOT** leave choke control on while operating the tractor. Doing so will result in a "rich" fuel mixture and cause the engine to run poorly.

Stopping the Engine

WARNING: If you strike a foreign object, stop the engine, disconnect the spark plug wire(s) and ground against the engine. Thoroughly inspect the machine for any damage. Repair damage before restarting.

1. If the blades are engaged, place the PTO lever in the "Blades Stop" position.
2. Turn the ignition key counterclockwise to the **OFF** position.
3. Remove the key from the ignition switch to prevent unintended starting.

Driving The Tractor

- Depress the brake pedal to release the parking brake.
- Move the throttle lever into the **FAST** (rabbit) position.
- To move forward, place the shift lever in the **FORWARD** position, then slowly depress the drive pedal until the desired speed is achieved. To move in reverse, place the shift lever in the **REVERSE** position, check that the area behind is clear then slowly depress the drive pedal.

Driving On Slopes

IMPORTANT: Refer to the **SLOPE GAUGE** on page 6 to help determine slopes where you may operate the tractor safely.

- Mow up and down slopes, **never** across.
- Watch for holes, ruts, bumps, rocks, or other hidden objects. Uneven terrain could overturn the machine. Tall grass can hide obstacles.
- Avoid turns when driving on a slope. If a turn must be made, attempt while going downward on the slope.
- Avoid stopping when driving up a slope. If it is necessary to stop while driving up a slope, start up smoothly and carefully to reduce the possibility of flipping the tractor over backward.

Mowing

The following information will be helpful when using the cutting deck with your tractor.

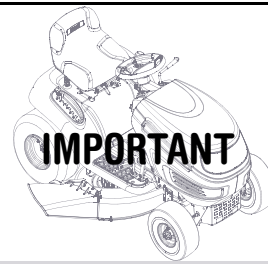

Do not leave the seat of the tractor without

1. disengaging PTO lever
2. depressing brake pedal
3. engaging parking brake

If leaving the tractor unattended, also turn the ignition key off and remove the key.

Do not use the shift lever to change the direction of travel when the tractor is in motion. Always use the brake pedal to bring the tractor to a complete stop before moving the shift lever.

Avoid sudden starts, excessive speed and sudden stops while driving the tractor.

Do not mow on slope in excess of 15 degrees (a rise of approximately 2-1/2 feet every 10 feet).

Keep hands and feet away from the opening of the cutting deck.

Plan your mowing pattern to avoid discharge of materials toward roads, sidewalks, bystanders and the like. Also, avoid discharging material against a wall or obstruction which may cause discharged material to ricochet back toward the operator.

- Do not mow at high ground speed, especially if a mulch kit or grass collector is installed.
- For best results it is recommended that the first two laps be cut with the discharge thrown towards the center. After the first two laps, reverse the direction to throw the discharge to the outside for the balance of cutting. This will give a better appearance to the lawn.
- Do not cut the grass too short. Short grass invites weed growth and yellows quickly in dry weather.
- Mowing should always be done with the engine at full throttle.
- Under heavier conditions it may be necessary to go back over the cut area a second time to get a clean cut.
- Do NOT attempt to mow heavy brush and weeds and extremely tall grass. Your tractor is designed to mow lawns, NOT clear brush.
- Keep the blades sharp and replace the blades when worn. Refer to **Cutting Blades** on page 19 of this manual for proper blade sharpening instructions.



WARNING: To help avoid blade contact or a thrown object injury, keep bystanders, helpers, children and pets at least 75 feet from the machine while it is in operation. Stop machine if anyone enters the area.

Side-Discharge

To operate the cutting deck for side-discharge of grass clippings only, remove the mulch plug by unthreading the plastic wing nut which fastens it to the cutting deck. This will allow the clippings to discharge out the side. See Figure 5.

(if equipped)

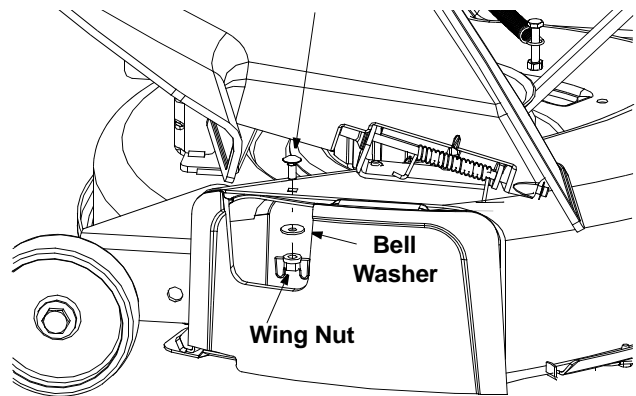

Figure 5

SECTION 5: MAKING ADJUSTMENTS



WARNING: Never attempt to make any adjustments while the engine is running, except where specified in the operator's manual. Disconnect spark plug wire(s) and ground against the engine before performing any adjustments, repairs or maintenance.

Seat



WARNING: Before operating this machine, make sure the seat is engaged in the seat stop, stand behind the machine and pull back on seat until fully engaged into stop.

1. Flip the seat up as shown in Figure 6.
2. Loosen the two seat adjustment knobs located under the seat. See Figure 6.
3. Slide the seat forward or rearward, then tighten the knobs to lock the seat at the desired position. Put the seat down to the operating position.

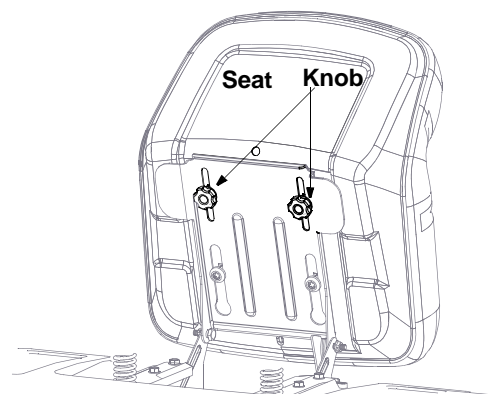

Figure 6

Steering

- If the tractor turns tighter in one direction than the other, or if the ball joints are being replaced due to damage or wear, the steering drag links may need to be adjusted. Adjust the drag links so that equal lengths are threaded into the ball joints on both sides.
1. Loosen the jam nut on the drag link at the rear of the ball joint. See Figure 7.
 2. Remove the hex nut and lock washer on top of the ball joint. See Figure 7.
 3. Thread the ball joint **toward** the jam nut to shorten the drag link.
 4. Thread the ball joint **away** from the jam nut to lengthen the drag link.
 5. Replace hex nut and lock washer and retighten the jam nut after proper adjustment is achieved.

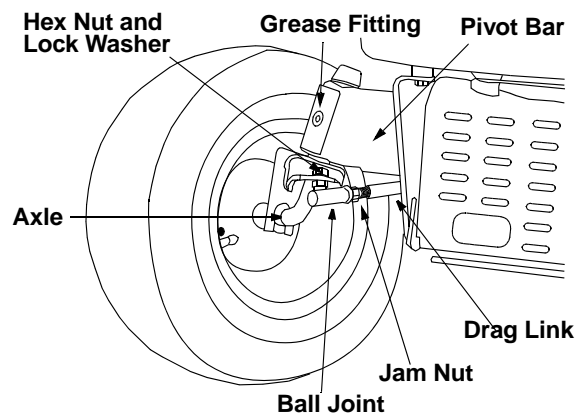

Figure 7

NOTE: Threading the ball joints too far on to the drag links will cause the front tires to "toe-in" too far. Proper toe-in is between 1/16" and 5/16".

Front tire toe-in can be measured as follows:

1. Place the steering wheel in position for straight ahead travel.
2. In front of the axle, measure the distance horizontally from the inside of the left rim to the inside of the right rim. Note the distance.
3. Behind the axle, measure the distance horizontally from inside of the left rim to the inside of the right rim. Note the distance.
4. The measurement taken in front of the axle should be between 1/16" and 5/16" less than the measurement taken behind the axle. Adjust if necessary.

Leveling the Deck

NOTE: Check the tractor's tire pressure before performing any deck leveling adjustments. Refer to Tires later in this section for further information regarding tire pressure.

Front To Rear

The front of the cutting deck is supported by a stabilizer bar that can be adjusted to level the deck from front to rear. The front of the deck should be between 1/4-inch and 3/8-inch lower than the rear of the deck. Adjust if necessary as follows:

1. With the tractor parked on a firm, level surface, place the deck lift lever in the top notch (highest position) and rotate the blade nearest the discharge chute so that it is parallel with the tractor.
2. Measure the distance from the front of the blade tip to the ground and the rear of the blade tip to the ground. The first measurement taken should be between 1/4" and 3/8" less than the second measurement. Determine the approximate distance necessary for proper adjustment and proceed, if necessary, to the next step.
3. Locate the two lock nuts on the opposite side of the stabilizer bracket. See Figure 8. Tighten the lock nuts to raise the front of the deck; loosen the lock nuts to lower the front of the deck.

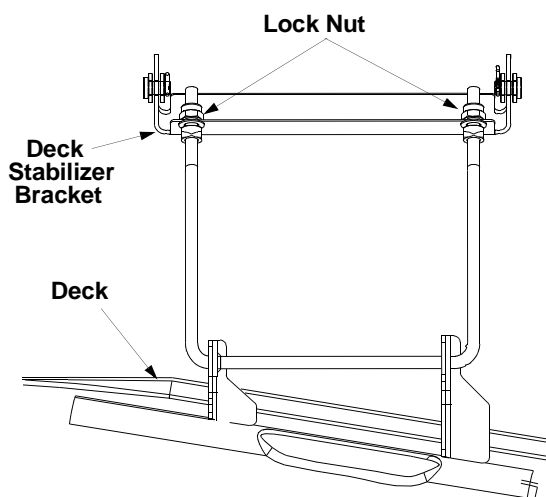

Figure 8

Side to Side

If the cutting deck appears to be mowing unevenly, a side to side adjustment can be performed. Adjust if necessary as follows:

1. With the tractor parked on a firm, level surface, place the deck lift lever in the top notch (highest position) and rotate both blades so that they are perpendicular with the tractor.
2. Measure the distance from the outside of the left blade tip to the ground and the distance from the outside of the right blade tip to the ground. Both measurements taken should be equal. If not, proceed to the next step.
3. Loosen, but do **not** remove, the hex cap screw on the left deck hanger bracket. See Figure 9.
4. To balance the deck turn the adjustment gear, located immediately behind the hex cap screw, clockwise/up or counterclockwise/down. See Figure 9. You will need an adjustable wrench for this step.
5. The deck is properly balanced when both blade tip measurements, taken earlier, are equal.
6. Retighten the hex cap screw on the left deck hanger bracket when proper adjustment is achieved.

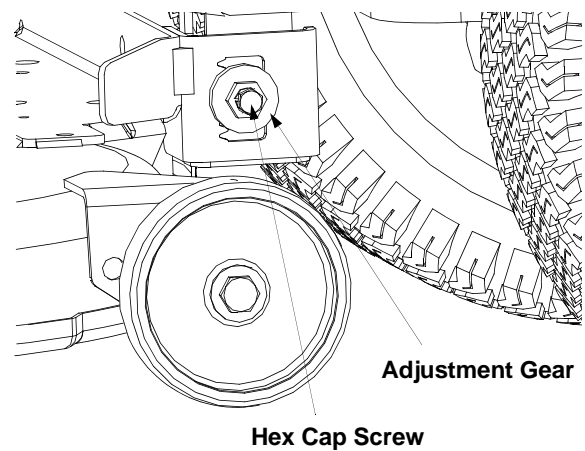

Figure 9

Parking Brake Adjustment



WARNING: Never attempt to adjust the brakes while the engine is running. Always disengage PTO, move shift lever into neutral position, stop engine and remove key to prevent unintended starting.

If the tractor does not come to a complete stop when the brake pedal is completely depressed, or if the tractor's rear wheels can roll with the parking brake applied, the brake is in need of adjustment. The brake disc can be found on the right side of the transmission in the rear of the tractor. Adjust if necessary as follows:

1. Looking at the transmission from the right side of the tractor, locate the compression spring and brake disc. See Figure 10.
2. Loosen, but do **not** remove, the hex nut found on the right side of the brake assembly. See Figure 10.
3. Using a feeler gauge, set the gap between the brake disc and the brake puck at .011".
4. Re-tighten the hex nut loosened earlier.

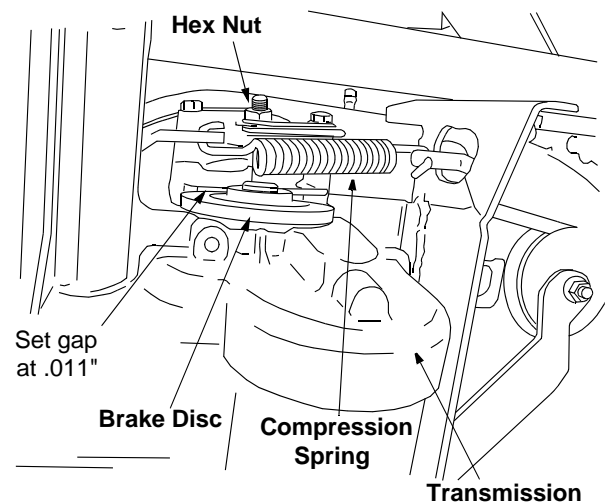

NOTE: View shown from beneath tractor.

Figure 10

SECTION 6: MAINTAINING YOUR LAWN TRACTOR



WARNING: Before performing any maintenance or repairs, disengage PTO, move shift lever into neutral position, set parking brake, stop engine and remove key to prevent unintended starting.

Lubrication

Engine

- Lubricate the engine with motor oil as instructed in the *engine manual*.

Pivot Points & Linkage

- Lubricate all pivot points on the drive system, parking brake and lift linkage at least once a season with light oil.

Rear Wheels

- Remove rear wheels from the axles once a season; lubricate the axles and rims with an all-purpose automotive grease and re-install the wheels

Front Wheels

- Each front wheel axle is equipped with a grease fitting; lubricate with a grease gun after every 25 hours of tractor operation or at least once a season.

Engine

Refer to the *engine manual* for engine maintenance instructions.

- Check engine oil level before each use as instructed in the *engine manual*. Read and follow instructions carefully. Refer to this manual for details about type and grade of oil.

Changing Engine Oil

1. Unscrew oil fill cap and remove dipstick from the oil fill tube. See Figure 11.
2. Pop open the protective cap on the end of the oil drain valve to expose the oil drain port. See Figure 11.
3. Push the oil drain hose (packed with this manual) onto the oil drain port. Route the opposite end of the hose into an appropriate oil collection container with a capacity great enough to collect the used oil (approximately 62 oz.).
4. Push the oil drain valve in slightly, then rotate counterclockwise and pull outward to begin draining oil. See Figure 11.
5. Service the oil filter as instructed in the *engine manual*.
6. Perform the above steps in the opposite order after oil has finished draining. Refill the engine with approximately 62 oz.(1.8 liters) of new motor oil.

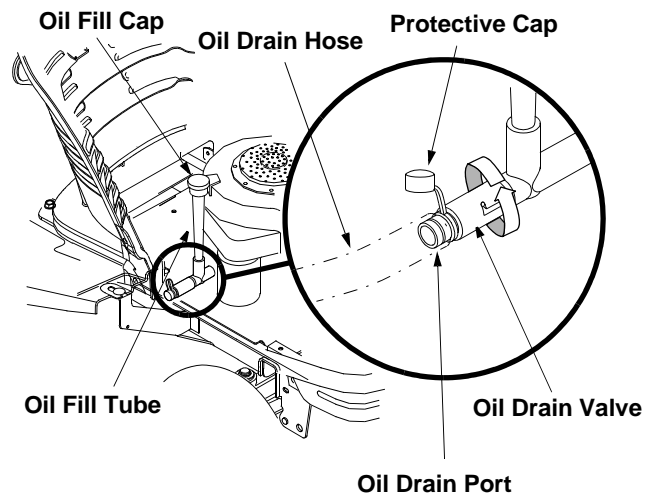

Figure 11

Air Cleaner

Service the pre-cleaner, if so equipped, and cartridge as instructed in the *engine manual* at the end of this manual.

Spark Plug

Clean the spark plug and reset its gap once a season, preferably at the start of each mowing season. Refer to the *engine manual* for correct plug type and gap specifications.

Cleaning The Engine & Deck

- Wipe off any fuel or oil spillage on the machine promptly. Do not allow grass, leaves, and dirt to accumulate around the cooling fins or on any other part of the machine, especially the pulleys and other moving parts.

IMPORTANT: The use of a pressure washer to clean your tractor is **not** recommended. Direct water pressure on electrical components and the engine could reduce life of the tractor and its serviceability.

Deck Wash System™ (if equipped)

- Use the Deck Wash System™ to rinse grass clippings from the deck's underside and prevent the buildup of corrosive chemicals. Complete the following steps **after** each mowing:

IMPORTANT: Make certain the tractor's discharge chute is directed **away** from your house, garage, parked cars, etc.

1. Drive the tractor to a level, clear spot on your lawn, near enough to a water sillcock (spigot) for your garden hose to reach.
2. Move PTO lever to "Blades Stop" position.
3. Move shift lever into neutral position.
4. Set the parking brake and stop engine.

5. Thread hose coupler (packaged with this manual) onto the end of your garden hose. See Figure 12.
6. Attach the hose coupler to the water port on your decks surface. See Figure 12. Turn the water on.
7. While sitting in the operator's position, re-start the engine and place throttle lever in FAST (rabbit) position.
8. Move the PTO (Blade Engage) Lever to ON position.
9. **Remain in the operator's position** with the cutting deck engaged for a minimum of two minutes, allowing the underside of the cutting deck to thoroughly rinse.
10. Move the PTO lever all the way back into the "Blade Stop" position.
11. Turn the ignition key to the STOP position to turn the tractor's engine off.
12. Turn the water off and detach the hose coupler from the water port on your decks surface.

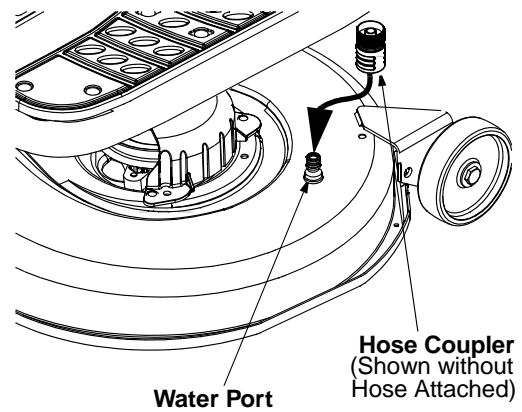

Figure 12

SECTION 7: SERVICE



WARNING: Before servicing, repairing, or inspecting, always disengage PTO, move shift lever into neutral position, set parking brake, stop engine and remove key from tractor to prevent unintended starting.

Tire Pressure

IMPORTANT: Never exceed the maximum inflation pressure shown on the sidewall of the tire.

- The recommended operating tire pressure is approximately 10 psi for the rear tires and 14 psi for the front tires. Refer to the tire sidewall for exact tire manufacturer's recommended or maximum psi. Do not overinflate. Uneven tire pressure could cause the cutting deck to mow unevenly.

Battery

The battery is sealed and maintenance-free. Acid levels cannot be checked. However, some care is required for long battery life:

- Always keep the battery cables and terminals clean and free of corrosive build-up.
- After cleaning the battery and terminals, apply a light coat of petroleum jelly or grease to both terminals
- Always keep the rubber boot positioned over the positive terminal to prevent shorting.

IMPORTANT: If removing the battery, disconnect the **negative** (black) wire from its terminal first, followed by the **positive** (red) wire. When re-installing the battery, always connect the positive (red) wire to its terminal first, followed by **negative** (black) wire.

Charging

- If the tractor has not been used for an extended period of time, use a voltmeter or load tester to measure the charge. The voltmeter should read

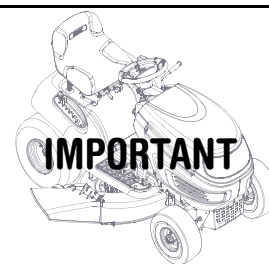

1. Battery wires must be connected to the correct terminals. Reversing them could change the polarity and damage engine's alternating system.
2. Do not jump-start a damaged battery.
3. When storing the battery, disconnect the negative terminal and store with full charge.

12.6 V or higher for adequate charge. Otherwise, charge the battery with an automotive-type 12-volt charger for a minimum of one hour at six amps. Follow the chart below to charge:

Voltmeter Reading	State of Charge (percentage)	Charging Time (minutes)
12.7	100	0
12.4	75	90
12.2	50	180
12	25	280



WARNING: Batteries give off an explosive gas while charging. Charge the battery in a well ventilated area and keep away from an open flame or pilot light as on a water heater, space heater, furnace, clothes dryer or other gas appliances.

Jump-Starting

IMPORTANT: Do not jump-start a damaged battery. Before connecting the jumper cables, make sure that the two equipment are not in contact and their ignitions are turned off. Follow the sequence described below very closely.

1. Connect the positive (+) lead of the jumper cable to the positive (+) post of the discharged battery.
2. Connect the other end of the positive (+) jumper cable to the positive (+) post of the good battery.
3. Connect one end of the negative (-) jumper cable to the negative (-) post of the good battery.
4. Connect the other end of the negative (-) cable to the engine block of the stalled tractor, **away** from the battery, and stand back.
5. Start the stalled tractor and leave it running to charge the battery.
6. Disconnect the negative (-) jumper cable from the tractor.
7. Disconnect the other end of the negative (-) jumper cable from the negative (-) post of the good battery.
8. Disconnect the positive (+) jumper cable from the positive (+) post of the good battery.
9. Disconnect the other end of the positive (+) jumper cable from the formerly dead battery.

Fuse

Two fuses are installed in your tractor's wiring harness to protect the tractor's electrical system from damage caused by excessive amperage.

- If the electrical system does not function, or your tractor's engine will not crank, first check to be certain that one of the fuses has not blown. One can be found under the hood mounted behind the top of the dash panel on the support bar. The other fuse is mounted to the inside of the frame, behind the battery. Pull each fuse out to determine if it is good or blown. Always use a fuse with the **same amperage** capacity for replacement.

Cutting Deck Removal

The cutting deck will have to be removed from the tractor for a variety of service tasks. To remove the cutting deck, proceed as follows:

1. Place the PTO Lever in the "Blades Stop" position and engage the parking brake.
2. Lower the deck by moving the deck lift lever into the bottom notch on the right fender.
3. Remove the PTO belt from around the engine pulley and from around the PTO idler pulley(s).
4. Looking at the cutting deck from the left side of the tractor, locate the deck support pin on the rear left side of the deck. See Figure 13.
5. Pull the deck support pin outward to release the deck from the deck lift arm.
6. Rotate the pin slightly toward the rear of the tractor and release the pin into the hole provided.

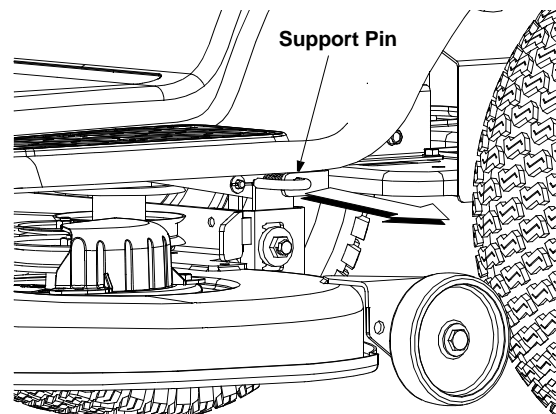

Figure 13

7. Repeat the above steps on the right side of the tractor.
8. Using a pair of needle nose pliers, pull out the cotter pin holding the deck cable. This will disconnect the cable.
9. Move the deck lift lever into the top notch on the right fender to raise the deck lift arms out of the way.
10. Gently slide the cutting deck toward the front of the tractor allowing the hooks on the deck to release themselves from the deck stabilizer rod. Do NOT let the deck fall to the ground.

Cutting Blades



WARNING: Shut tractor engine off, remove ignition key, disconnect the spark plug wire(s) and ground against the engine before proceeding with job. Protect your hands by using heavy gloves or a rag to grasp the cutting blade

- Periodically inspect the blade adapter and/or spindle for cracks or damage, especially if you strike a foreign object. Replace immediately if damaged. Remove the blades following instructions below:
 1. Remove the deck from beneath the tractor, then gently flip the deck over to expose its underside.
 2. Place a block of wood between the center deck housing baffle and the cutting blade to act as a stabilizer. See Figure 14.
 3. Using a 15/16" wrench, remove the hex flange nut that secures the blade to the spindle assembly. See Figure 14.
 4. To properly sharpen the cutting blades, remove equal amounts of metal from both ends of the blades along the cutting edges, parallel to the trailing edge, at a 25° to 30° angle. See Figure 14.
- If the cutting edge of the blade has already been sharpened to within 5/8" of the wind wing radius, or if any metal separation is present, replace the blades with new ones. See Figure 14.

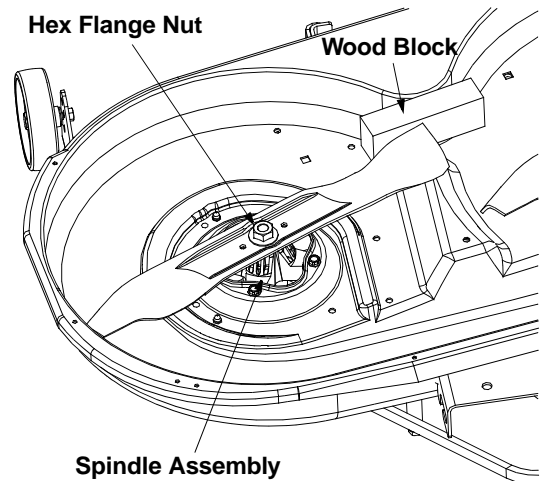

IMPORTANT: Each cutting blade edge has to be ground equally to maintain proper blade balance. A poorly balanced blade will cause excessive vibration, may damage the tractor and/or result in personal injury.

5. Test the blade by balancing it on a round shaft screwdriver. Grind metal from the heavy side until it balances evenly.
6. When replacing the blade, be sure to install the blade with the side of the blade marked "Bottom" (or with a part number stamped in it) facing the ground when the mower is in the operating position.
7. Use a torque wrench to tighten the blade spindle hex flange nut to between 70 and 90 foot-pounds.
8. Gently slide the cutting deck (from the right side) out from underneath the tractor.

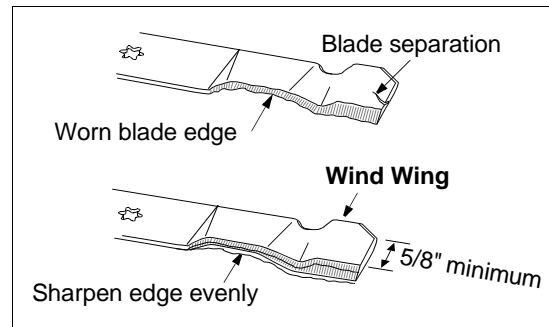

Figure 14

Changing the Deck Belt(s)



WARNING: Shut tractor engine off, remove ignition key, disconnect the spark plug wire(s) and ground against the engine before proceeding with job.

IMPORTANT: The V-belts on your tractor are specially designed to engage and disengage safely. A substitute (non-OEM) V-belt can be dangerous by not disengaging completely. For a proper working machine, use factory approved belts.

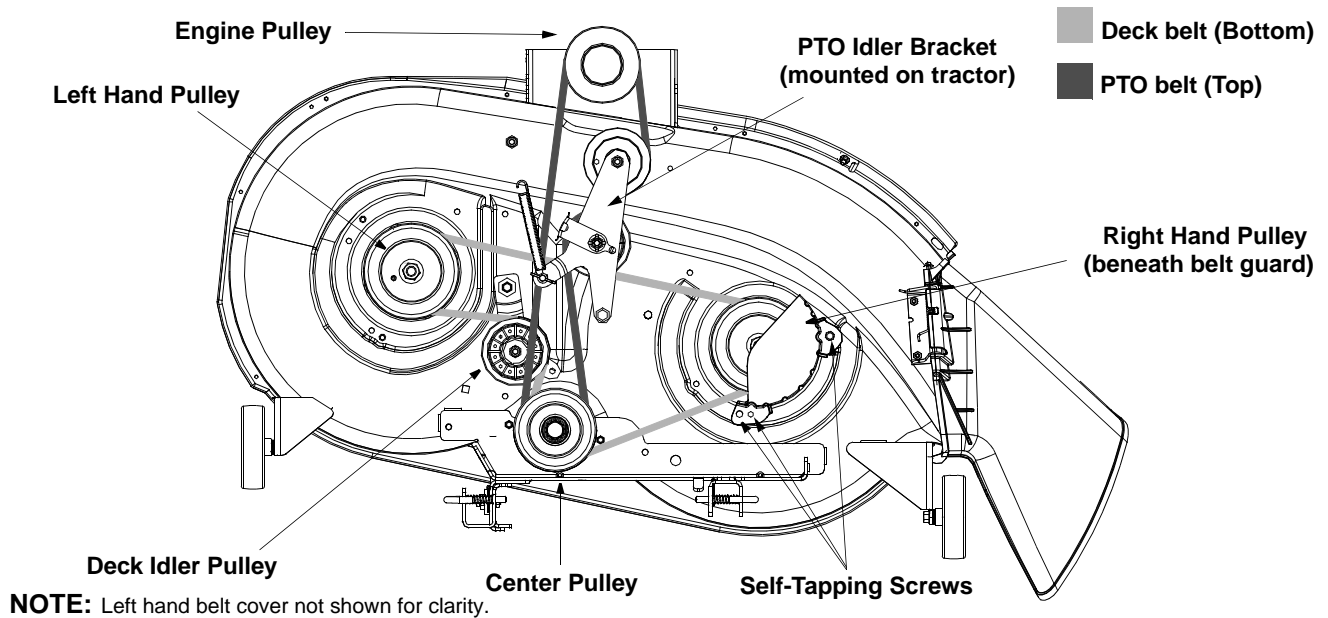

Figure 15

- All belts on the tractor are subject to wear and should be replaced if cracking, shredding or rotting occurs. To change or replace the deck belts on your tractor, proceed as follows:
 1. Lower the deck by moving the deck lift lever into the bottom notch on the right fender.
 2. Remove the belt guards by removing the self-tapping screws that fasten them to the deck surface. See Figure 15 for location of the screws.
 3. Grasp the PTO idler bracket and pivot it toward the discharge chute to relieve tension on the PTO belt.
 4. Remove the PTO belt from the electric PTO clutch and from around the PTO idler pulley.
 5. Grasp the deck idler pulley and pivot it toward the left side of the deck to relieve tension on the deck belt.
 6. Remove the belt from around all pulleys, including the deck idler pulley.
 7. Route the new belts as shown in Figure 15. Remount the belt guards removed earlier.

Changing Transmission Drive Belt

NOTE: It is recommended that both drive belts be replaced at the same time.

1. Remove the cutting deck as instructed earlier in this section.
2. After disconnecting the battery cables, remove the battery and battery tray from beneath the seat.

IMPORTANT: When removing the battery, disconnect the **NEGATIVE (Black)** wire from its terminal first, followed by the **POSITIVE (Red)** wire. Re-install in reverse order.

Upper Drive Belt

1. Locate the transmission idler pulley on the upper drive belt by looking through the battery tray opening. See Figure 16.
2. Grasp the bracket and pivot the transmission idler pulley toward the rear of the tractor to release tension on the upper drive belt.
3. Remove the belt from around the transmission idler pulley.
4. Remove the upper drive belt from around the transmission pulley and the variable-speed pulley. Slowly rotate the pulley counterclockwise to roll the belt off it.

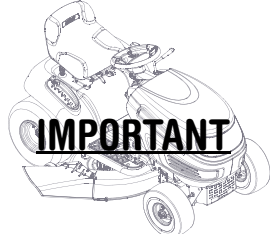

IMPORTANT

1. While installing replacement belts, it is essential to follow the same routing map as the original.
2. Proper removal of the lower drive belt requires the removal of several tractor components. Read through the following procedure prior to attempting it to determine if you could successfully complete it. Otherwise, see your Troy-Bilt dealer .

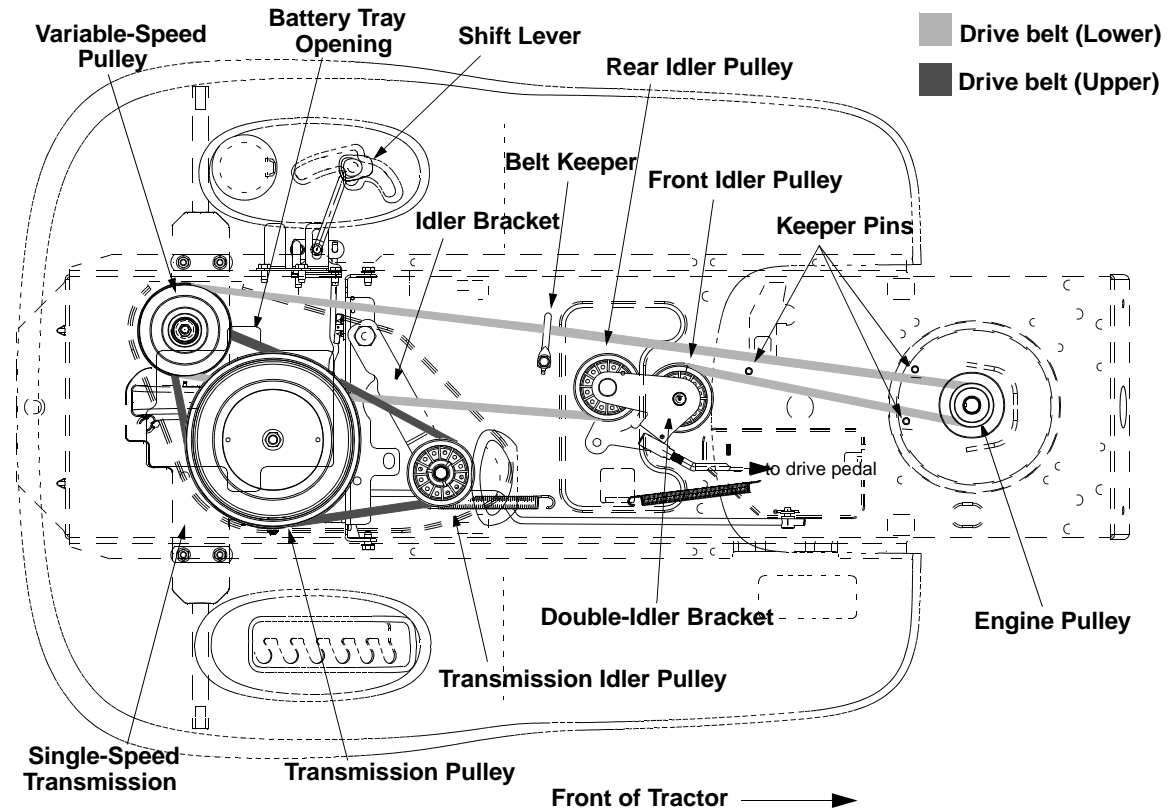

NOTE: View shown from above tractor.

Figure 16

5. Remove the upper drive belt by pulling it up through the battery tray opening.
6. Reroute the new upper drive belt as shown in Figure 16.

Lower Drive Belt

IMPORTANT: Note the routing of the lower drive belt around both the pulleys and the belt keepers **before** performing the following steps.

1. Locate the variable-speed pulley through the battery tray opening. See Figure 16.
2. Remove the variable-speed pulley by loosening the hex bolt that secures it to the transmission. Use a second wrench to hold the hex nut on the bottom side of the pulley.
3. Slide the belt off the variable-speed pulley as you lift the pulley up and out through the battery tray opening.
4. Remove the rear idler pulley from the double-idler bracket while unrouting the belt from around both the rear and the front idler pulley. See Figure 16.
5. Remove the hex bolt from the center of the engine pulley and gently lower it off the engine crankshaft. Be careful not to lose any washers or spacers which may be on top of the engine pulley.

IMPORTANT: When remounting the engine pulley, torque the center hex bolt to between 38 and 50 foot-pounds.

6. Remove drive belt by feeding it from both ends toward the front idler pulley on the double-idler bracket. See Figure 16.
7. Reassemble by following the above steps in reverse order. Reroute the new belt around the pulleys, belt keepers and keeper pins **exactly** as the old one was routed. Refer to Figure 16.
- The drive pedal is properly adjusted when the hole in the double-idler bracket has approximately 1-3/8" of travel with 10 lbs. pressure applied to the drive pedal. See Figure 17.

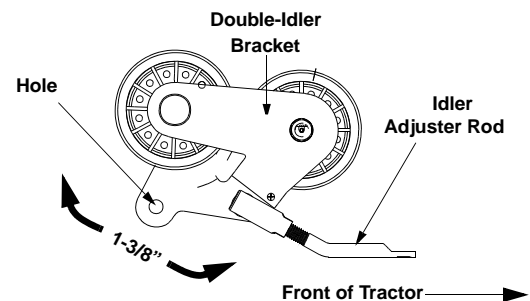

NOTE: View shown from above tractor.

Figure 17

After replacing the drive belts, adjust the drive pedal on your tractor as follows:

1. Locate the speed control assembly on the underside of the steering support bracket. See Figure 18.
2. Remove both hairpin clips from the pin which is fastened to the speed control assembly (be careful not to lose the small flat washers found on the pin). See Figure 18.
3. Remove the drive pedal return spring.
4. Using two 9/16" wrenches, remove the pin from the speed control assembly. See Figure 18.
5. Thread the idler adjustment rod inward or outward to lengthen or shorten the travel of the double-idler bracket until proper adjustment is achieved.
6. Reassemble by following the above steps in reverse order.

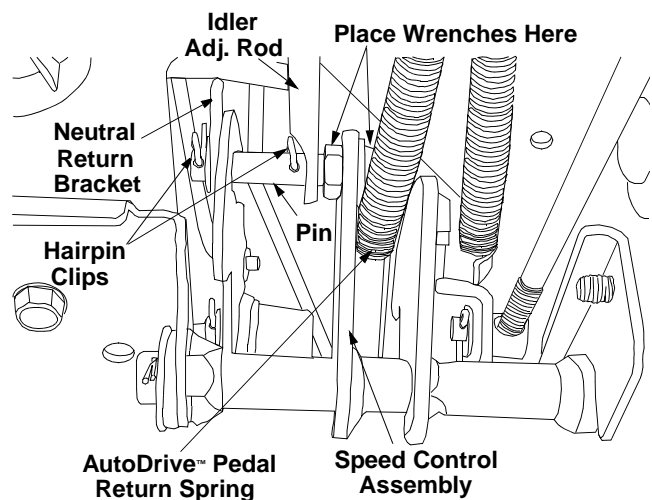

Figure 18

SECTION 8: OFF-SEASON STORAGE

WARNING: Never store the machine or fuel container indoors where there is an open flame, spark or pilot light such as on water heater, furnace, clothes dryer or other gas appliance.

- Clean and lubricate the tractor as instructed on page 15 before storing for an extended period.

WARNING: Drain fuel only into an approved container outdoors, away from an open flame. Allow engine to cool. Extinguish cigarettes, cigars, pipes, and other sources of ignition prior to draining fuel.

- Follow instructions in the **Seasonal Storage** section of the *engine manual* for proper engine care prior to storing your tractor.
- It is not necessary to remove the battery from the tractor for storage. However, clean the top of the battery and make sure it has full charge. Disconnect the negative terminal of the battery before storing the tractor.

NOTE: Recharge the battery before returning it to service after storage. Even if the tractor starts, the engine charging system may not bring the battery up to a full charge, unless it is recharged.

Attachments & Accessories

The following attachments and accessories are available for your lawn tractor. See your local *Troy-Bilt* dealer for price and availability.

MODEL	DESCRIPTION
OEM-190-116	Mulch Kit
OEM-190-180	FastAttach™ Twin Bagger Grass Collector
OEM-190-603	FastAttach™ Grille Guard (mounts on front of tractor)
OEM-190-604	FastAttach™ Yard-Mate™ Storage Container/Toolbox (mounts on rear of tractor)
OEM-190-607	FastAttach™ Deluxe Tractor Sunshade
OEM-190-822	FastAttach™ 46-inch Front Dozer Blade
OEM-190-823	FastAttach™ 42-inch Two-stage Snow Thrower

SECTION 9: TROUBLESHOOTING

Trouble	Possible Cause(s)	Corrective Action
Engine fails to start	<ol style="list-style-type: none"> 1. PTO lever engaged. 2. Parking brake not engaged. 3. Spark plug wire(s) disconnected. 4. Throttle control lever not in correct starting position. 5. Fuel tank empty, or stale fuel. 6. Blocked fuel line. 7. Faulty spark plug. 8. Engine flooded. 	<ol style="list-style-type: none"> 1. Place PTO lever in OFF position. 2. Engage parking brake. 3. Connect wire(s) to spark plug. 4. Place throttle lever to CHOKE position. 5. Fill tank with clean, fresh gas. 6. Clean fuel line or replace fuel filter, if so equipped. 7. Clean, adjust gap or replace plug. 8. Crank engine with throttle in FAST position.
Engine runs erratic	<ol style="list-style-type: none"> 1. Unit running with CHOKE applied. 2. Spark plug wire loose. 3. Blocked fuel line or stale fuel. 4. Vent in gas cap plugged. 5. Water or dirt in fuel system. 6. Dirty air cleaner. 	<ol style="list-style-type: none"> 1. Place throttle lever in FAST position. 2. Connect and tighten spark plug wire. 3. Clean fuel line; fill tank with clean, fresh gas. Replace fuel filter, if so equipped. 4. Clear vent or replace cap if damaged. 5. Drain fuel tank. Refill with clean, fresh gas. 6. Replace air cleaner cartridge or clean pre-cleaner, if so equipped.
Engine overheats	<ol style="list-style-type: none"> 1. Engine oil level low. 2. Air flow restricted. 	<ol style="list-style-type: none"> 1. Fill crankcase with proper capacity and weight of oil. 2. Clean grass clippings and debris from around the engine's cooling fins and blower housing.
Engine hesitates at high RPM	<ol style="list-style-type: none"> 1. Spark plug gap too close. 	<ol style="list-style-type: none"> 1. Remove spark plug(s) and reset the gap at .030".
Idles poorly	<ol style="list-style-type: none"> 1. Spark plug fouled, faulty or gap too wide. 2. Dirty air cleaner. 	<ol style="list-style-type: none"> 1. Replace spark plug(s). Set plug gap at .030". 2. Replace air cleaner cartridge or clean pre-cleaner, if so equipped.
Excessive vibration	<ol style="list-style-type: none"> 1. Cutting blade loose, unbalanced or damaged. 	<ol style="list-style-type: none"> 1. Tighten blade and spindle, balance blade and/or replace blade.
Mower will not mulch grass	<ol style="list-style-type: none"> 1. Engine speed too low. 2. Wet grass. 3. Excessively high grass. 4. Dull blade. 	<ol style="list-style-type: none"> 1. Place throttle in FAST (rabbit) position. 2. Do not mow when grass is wet; wait until later to cut. 3. Mow once at a high cutting height, then mow again at desired height or make a narrower cutting swath. 4. Sharpen or replace blade.
Uneven cut	<ol style="list-style-type: none"> 1. Deck not balanced properly. 2. Dull blade. 3. Uneven tire pressure. 	<ol style="list-style-type: none"> 1. Perform side-to-side deck adjustment. 2. Sharpen or replace blade. 3. Check tire pressure in all four tires.

SECTION 10: PARTS LIST FOR MODELS J609 & T609

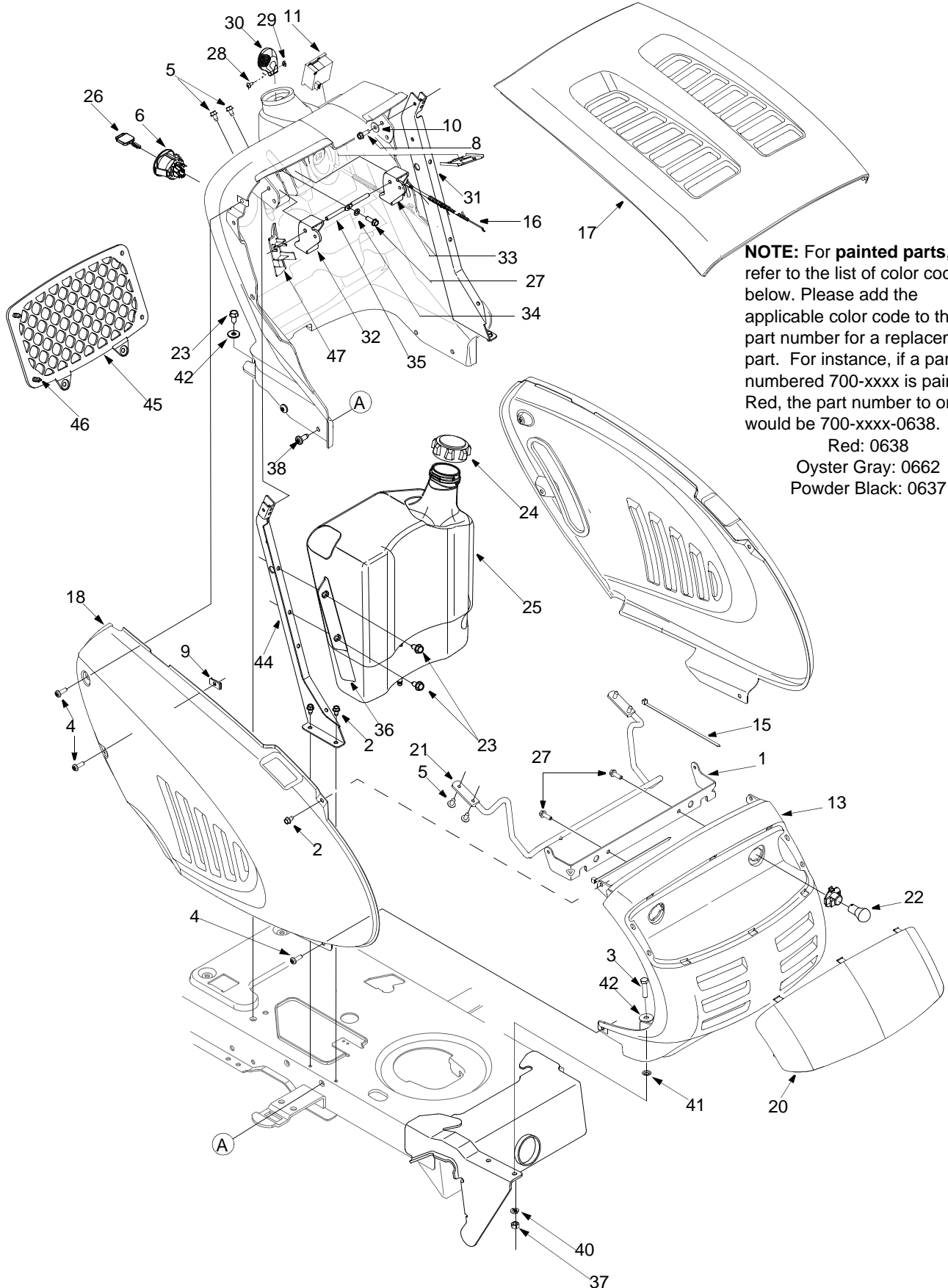

NOTE: For painted parts, refer to the list of color codes below. Please add the applicable color code to the part number for a replacement part. For instance, if a part numbered 700-xxxx is painted Red, the part number to order would be 700-xxxx-0638.

Red: 0638
 Oyster Gray: 0662
 Powder Black: 0637

Models J609 & T609

Ref. No.	Part No.	Description	Ref. No.	Part No.	Description
1	783-1346	Grill Support Bracket (9-style)	27	710-0895	Self-tapping Screw, 1/4-15 x .75
2	710-0599	Self-tapping Screw, 1/4-20 x .5	28	710-3217	Truss Phillips Screw, #8-32 x .375
3	710-0528	Hex Cap Screw, 5/16-18 x 1.25	29	712-0142	Hex Nut, #8-32
4	710-0924	Phillips Pan Screw, 1/4-20 x .75	30	731-1857	Throttle Control Knob
5	710-1017	Truss Phillips Screw, 1/4-20 x .625	31	731-2122C	Dash Panel
6	725-1741	Ignition Switch	32	731-04217	Cruise Control Button
7	735-04019	Side Panel Seal	33	731-04215	Parking Brake Button
8	710-0642	Self-tapping Screw, 1/4-20 x .75	34	736-0142	Flat Washer, 9/32 x 1/2 x 1/16
9	712-0292	U-type Speed Nut, 1/4-20	35	747-1196	Brake/Cruise Pivot Rod
10	736-0270	Bell Washer, .265 x .75 x .062	36	783-04285	Dash Support Plate RH
11	725-04156	Ammeter		783-04323	Dash Support Plate LH
12	712-3004A	Hex Nut, 5/16-18	37	712-3010	Hex Nut, 5/16-18
13	731-2119A	Grille (9-style)	38	710-1611B	Self-tapping Screw, 5/16-18 x .75
15	725-0157	Cable Tie, 3/16 x .05 x 7.4	39	726-3046	Ratchet Clip
16	746-1085	Choke Knob/Cable (Model LTX-2146)	40	736-0119	Lock Washer, 5/16
17	783-0783	Hood (9-style)	41	726-0201	Speed Nut, .3125
18	783-0784	RH Side Panel (9-style)	42	736-3078	Flat Washer, .349 x 1.0 x .063
19	783-04200	LH Side Panel (9-style)	43	710-1238	Screw, 5/16-18 x .875 (Grade 5)
20	731-2637	Headlight Lens (9-style)	44	747-04158	Fuel Tank Support RH
21	747-2138	Hood Hinge Rod		747-04161	Fuel tank Support LH
22	625-0051	Headlight Assembly	45	735-04023	Cargo Net
23	710-0726	Self-tapping Screw, 5/16-12 x .75	46	726-04029	Clip: Cargo Net
24	751-0603	Fuel Cap	47	731-2228	Cover: Cruise Control
25	751-0658D	Fuel Tank, Three-Gallon	—	629-0469A	Headlight Wire Harness (Not Shown)
26	725-1745	Ignition Key w/ plastic cover	—	629-04050	Tractor Wire Harness (Not Shown)
	725-1744	Ignition Key w/o plastic cover			

Models J609 & T609

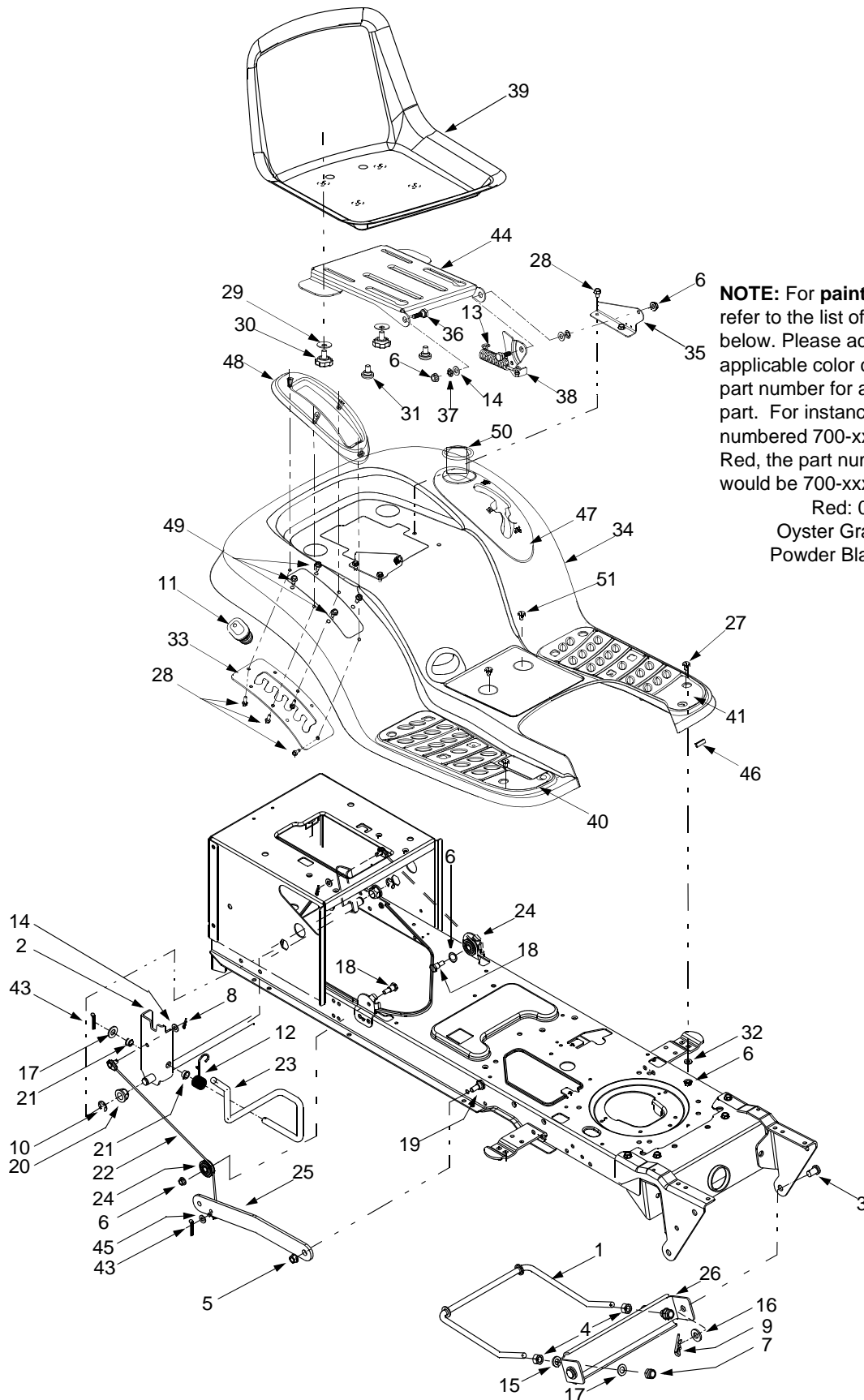

NOTE: For painted parts, refer to the list of color codes below. Please add the applicable color code to the part number for a replacement part. For instance, if a part numbered 700-xxxx is painted Red, the part number to order would be 700-xxxx-0638.

Red: 0638
 Oyster Gray: 0662
 Powder Black: 0637

Models J609 & T609

Ref. No.	Part No.	Description	Ref. No.	Part No.	Description
1	747-1130B	Deck Stabilizer Rod	26	783-0720A	Deck Stabilizer Bracket
2	683-0197B	Lift Shaft Assembly	27	710-0260A	Carriage Bolt, 5/16 x .62
3	711-0332	Clevis Pin, .5 x .78	28	710-0604A	Self-tapping Screw, 5/16-18 x .625
4	712-0206	Hex Nut, 1/2-13	29	736-0331	Bell Washer, .390 x 1.13 x .062
5	712-0431	Flange Lock Nut, 3/8-16	30	720-04009	Knob, 3/8-16
6	712-0429	Flange Lock Nut, 5/16-18	31	738-04012	Shoulder Screw
7	712-3083	Hex Nut, 1/2-13	32	736-3078	Flat Washer, .349 x 1.0 x .063
8	714-0104	Internal Cotter Pin	33	783-1010A	Lift Adjustment Bracket
9	714-0145	Internal Cotter Pin	34	783-04314	Fender
10	716-0106	E-Ring	35	783-1489	Seat Mounting Bracket
11	720-0311	Handle Grip	36	738-0296	Shoulder Screw
12	732-0874	Torsion Spring	37	726-0201	Speed Clip
13	732-1184	Extension Spring, .84 x 4.6	38	783-0209A	Seat Lift Bracket
14	736-0275	Flat Washer, 5/16	39	757-04001	Seat: Low Back
15	736-0921	Lock Washer, 1/2	40	735-0672	RH Foot Pad, Rubber
16	736-3019	Flat Washer, .531 x 1.062 x .134	41	735-0673	LH Foot Pad, Rubber
17	736-3084	Flat Washer, .51 x 1.12 x .06	42	726-3046	Foot Pad Clips
18	738-0138A	Hex Cap Screw, 5/16-18 x .62	43	714-0111	Cotter Pin
19	738-0143	Shoulder Screw, 3/8-16	44	783-04081	Seat Pivot Bracket
20	741-0225	Hex Flange Bearing	45	736-0204	Flat Washer, .344 x .62
21	741-0715	Snap Flange Bearing	46	731-0511	Trim Strip
22	746-0968	Lift Cable, 16.16 (LTX-1842)	47	731-1990	Lift Lever Cover
	746-1144	Lift Cable, 15.62 (LTX-2146)	48	731-2104B	Shift Lever Cover w/ Cup Holder
23	747-1111A	Lift Handle	49	710-0895	Self-Tapping Screw, 1/4-15 x .75
24	756-1154	Roller Pulley	50	731-04591	Cup Holder
25	783-0678A	Lift Arm	51	710-0599	TT Screw, 1/4-20 x 0.5

Models J609 & T609

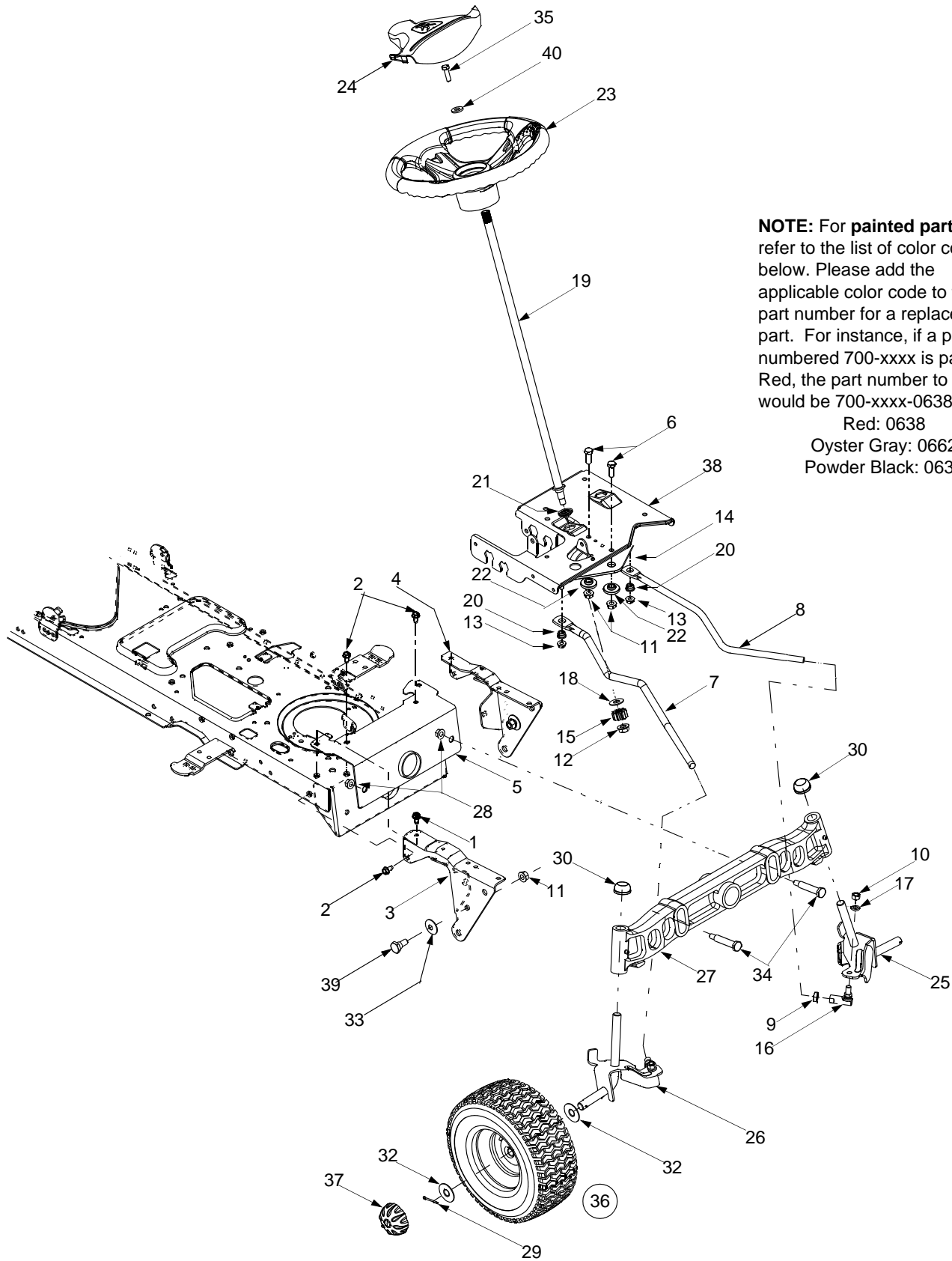

NOTE: For painted parts, refer to the list of color codes below. Please add the applicable color code to the part number for a replacement part. For instance, if a part numbered 700-xxxx is painted Red, the part number to order would be 700-xxxx-0638.

Red: 0638
 Oyster Gray: 0662
 Powder Black: 0637

Models J609 & T609

Ref. No.	Part No.	Description	Ref. No.	Part No.	Description
1	710-1260A	Self-tapping Screw, 5/16-18 x .75	25	638-0019A	LH Axle Assembly, (Model LTX-1842)
2	710-0604A	Self-tapping Screw, 16-18 x .625		638-0021	LH Axle Assembly (Model LTX-2146)
3	783-0726B	RH Pivot Support Bracket	26	638-0020A	RH Axle Assembly (Model LTX-1842)
4	783-0727A	LH Pivot Support Bracket		638-0022	RH Axle Assembly (Model LTX-2146)
5	783-0728	Pivot Bar Bracket	27	719-0399B	Pivot Bar w/ Fittings (Model LTX-1842)
6	710-0514	Hex Cap Screw, 3/8-16 x 1 (Grade 5)		719-0525B	Pivot Bar w/ Fittings (Model LTX-2146)
7	711-1408	RH Drag Link	28	712-0431	Flange Lock Nut, 3/8-16
8	711-1409A	LH Drag Link	29	714-0162	Cotter Pin
9	712-0240	Jam Nut, 7/16-20 (Grade 2)	30	726-0214	Push Cap, .625 (Model LTX-1842)
10	712-0214	Hex Nut		726-0341	Push Cap, .750 (Model LTX-2146)
11	712-0130	Flange Lock Nut, 3/8-24	32	736-0430	Flat Washer
12	712-0459	Flange Lock Nut, 7/16-20	33	736-0331	Bell Washer, .39 x 1.13 x .062
13	712-0429	Flange Lock Nut, 5/16-18	34	738-1011	Shoulder Screw, .5 x 2.2, 3/8-16
14	717-1550D	Steering Gear, 11/90 Ratio	35	710-0643	Hex Bolt, 5/16-18 X 1
15	717-1554	Steering Pinion Gear	36	634-04086	Wheel Assembly Complete, 15 x 6 x 6
16	723-0448A	Ball Joint, 7/16-20	—	634-04081	Rim Only
17	736-0169	Lock Washer, 3/8	—	734-0255	Air Valve (Not Shown)
18	736-3084	Flat Washer, .51 x 1.12 x .06	—	734-1731	Tire Only, Square Shoulder
19	738-1001A	Steering Shaft, .625 OD x 24.4	—	741-0516A	Flange Bearing (Not Shown)
20	741-0475	Plastic Bushing, .38 ID	—	741-0990A	Flange Bearing (Not Shown)
21	741-0656	Hex Flange Bearing, 5/8	37	734-2290A	Hub Cap
22	738-0372B	Shoulder Spacer, .38 ID	38	783-0653F	Steering Support Bracket
23	631-04008	Steering Wheel, Soft Grip, Three Spoke	39	738-0143	Shoulder Screw, 3/8-16
24	731-04681	Steering Wheel Cover	40	736-3004	Flat Washer, .406 x .875 x .105

Models J609 & T609

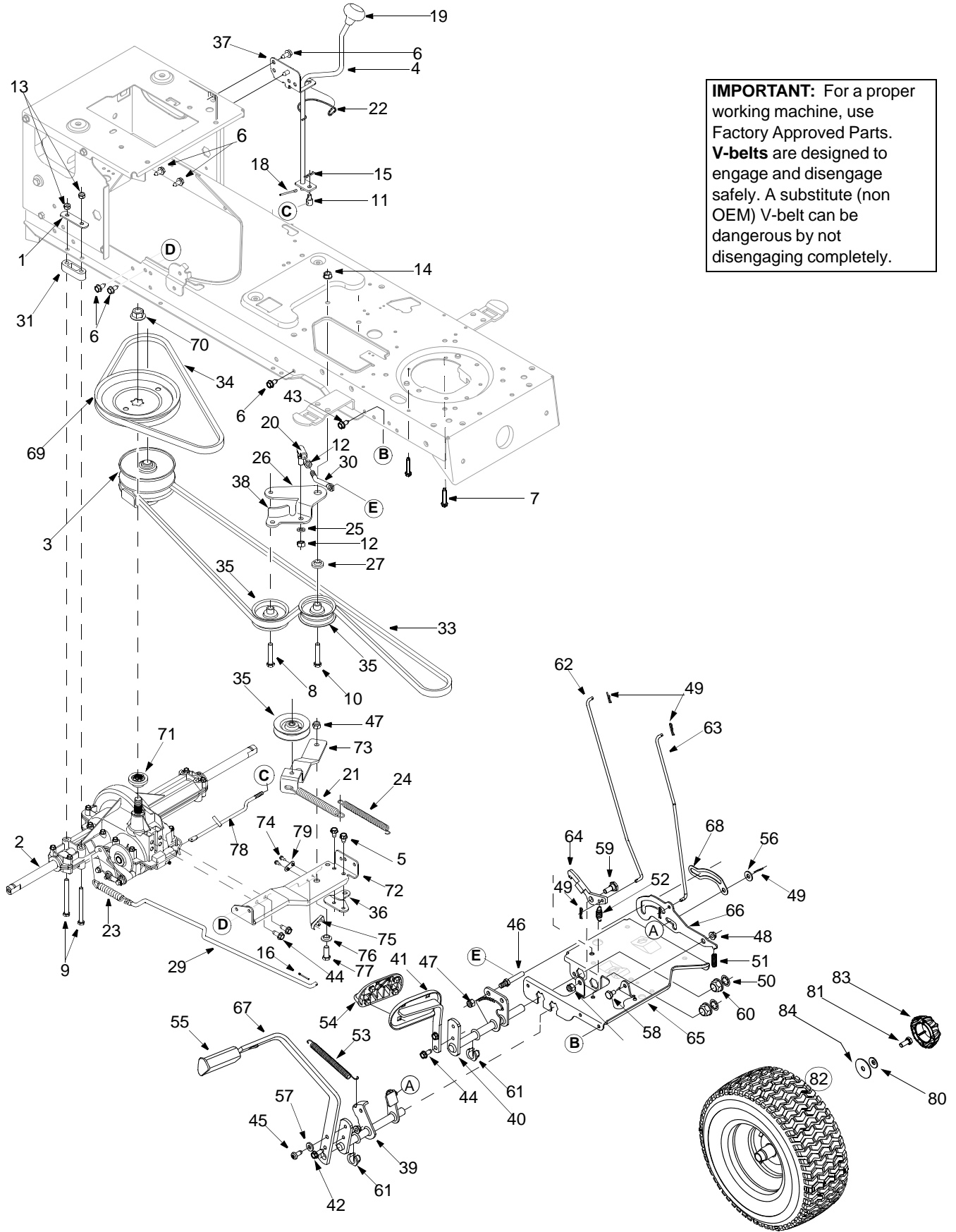

IMPORTANT: For a proper working machine, use Factory Approved Parts. **V-belts** are designed to engage and disengage safely. A substitute (non OEM) V-belt can be dangerous by not disengaging completely.

Models J609 & T609

Ref. No.	Part No.	Description	Ref. No.	Part No.	Description
1	17840	Mounting Bracket	45	710-1611B	TT Screw 5/16-18 x 0.75
2	618-04133	Drive Assembly	46	711-04159	Pin
3	618-04147	Variable Spd. Pulley Assembly	47	712-0130	Hex Lock Nut 3/8-16
4	647-04020	Shift Lever Assembly	48	712-3004A	Flange Lock Nut
5	710-0607	TT Screw 5/16-18 x 0.5	49	714-0104	Cotter Pin
6	710-0726	AB Screw 5/16-12 x 0.75	50	726-04028	Push Nut
7	710-0809	TT Screw 1/4-20 x 1.25	51	732-0335	Compression Spring
8	710-1007	TT Sems Screw 3/8-16 x 1.5	52	732-0955	Extension Spring
9	710-1266	Hex Bolt 5/16-18 x 3.5	53	732-0963	Extension Spring
10	710-3144	Hex Bolt 3/8-16 x 2.0	54	735-0662	Control Pad
11	711-0736	Ferrule	55	735-3049	Brake Pad
12	712-0241	Hex Nut 3/8-24	56	736-0262	Flat Washer
13	712-0429	Hex Lock Nut 5/16-18	57	736-3008	Flat Washer
14	712-0431	Flange Lock Nut 3/8-16	58	738-0155	Shoulder Screw
15	714-0104	Hairpin Clip	59	738-0380	Shoulder Screw
16	714-0111	Cotter Pin	60	741-0225	Hex Flange Bearing
17	714-0209	Hairpin Clip	61	741-3065B	Hex Flange Bearing: Split
18	714-0470	Cotter Pin	62	747-04093	Brake Lock Rod
19	720-04028	Shift Knob	63	747-04096	Cruise Control Rod
20	723-3018	Ball Joint	64	748-04039	Cruise Latch
21	732-0384	Extension Spring	65	783-0653F	Steering Support Bracket
22	732-0525	Spring Clip	66	783-0732	Lock-Out Bracket
23	732-0716	Extension Spring	67	783-0773A	Brake Pedal
24	732-0963	Extension Spring	68	783-0780B	Neutral Return Bracket
25	736-0169	Lock Washer 3/8	69	756-04002	Transmission Pulley
26	737-3007	Grease	70	712-0700	Flange Nut 9/16-18
27	738-0372B	Shoulder Spacer	71	718-0758A	Pulley Hub
28	747-04146	Shift Rod	72	683-04055	Transmission Torque Bracket
29	747-04164	Brake Rod	73	683-04130	Idler Bracket
30	747-1127	Idler Adj. Rod	74	710-0227	AB Screw #8-18 x 0.5
31	748-0334	Spacer: Transaxle	75	725-1644	Spring Switch
32	750-0566A	Spacer	76	750-0736	Shoulder Spacer
33	754-0467	V Belt	77	710-0514	Hex Bolt 3/8-16 x 1.0
34	754-0468	V Belt	78	747-04146	Shift Rod
35	756-0981A	Flat Idler Pulley	79	726-0320	Insulator Nut Plate
36	783-04283	Shift Bracket	80	736-0242	Bell Washer
37	783-04360	Shift Bracket	81	710-0627	Hex Cap Screw
38	783-04442	Double Idler Bracket: Center	82	634-0104	Wheel Assembly
39	647-0031C	Brake Control Assembly		634-0070	Rim Assembly
40	647-0032A	Speed Control Assembly		734-0255	Air Valve
41	683-0266	Drive Pedal Assembly		734-1730	Tire
42	710-0650	TT Screw 5/16-18 x 0.875	83	734-2290A	Hub Cap
43	710-0726	AB Screw 5/16-12 x 0.75	84	736-0430	Flat Washer
44	710-1260A	LD Screw 5/16-18 x 0.75			

Models J609 & T609

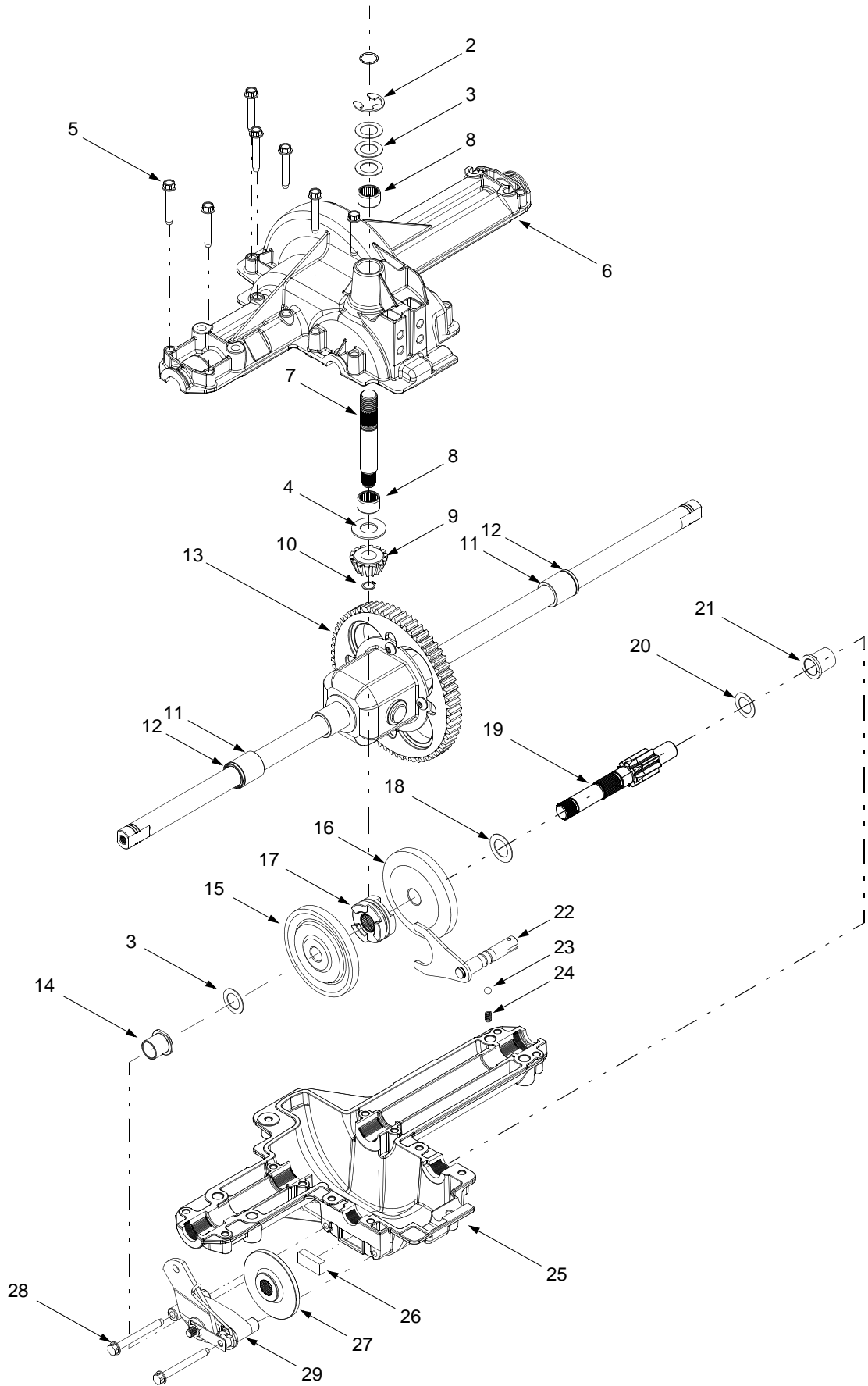

Models J609 & T609

Ref. No.	Part No.	Description
1	732-0614	Ring, Wire
2	716-0231	Ring, E Type, .750
3	736-0336	Flat Washer, 5/8 x 1.0 x .030*
	736-0337	Flat Washer, 5/8 x 1.0 x .040*
	736-0349	Flat Washer, 5/8 x 1.0 x .020*
4	736-0335	Washer, Thrust .635 x 1.26 x .06
5	710-1325	Self-tapping Screw, 1/4-20 x 1.625
6	719-04017	Upper Housing
7	711-1109	Input Shaft
8	741-0335	Needle Bearing, .625 x .813 x .495
9	717-1464	14-tooth Bevel Pinion
10	716-0108	Retaining Ring, .437
11	741-0340	Sleeve Bearing, .75 x .1.0 x 1.0
12	721-0338	Seal, .75 x 1.0 x .125
13	618-04041	Differential Assembly
14	741-0336	Flange Bearing, 5/8 x 3/4 x 3/4
15	717-1362	42-tooth Bevel Gear
16	717-1363	42-tooth Bevel Gear
17	718-0228	Clutch Collar
18	736-0519	Flat Washer, .70 x 1.125 x .031
19	711-04053	Drive Shaft
20	736-0495	Thrust Washer, 1.0 x .632 x .0
21	741-0337	Flange Bearing, 5/8 x 3/4 x 15/16
22	611-0011	Detent Shaft Assembly
23	741-0862	Detent Ball
24	732-0863	Compression Spring
25	719-04018	Lower Housing
26	717-0678	Brake Puck
27	761-0202	Brake Disc
28	710-1206	Self-tapping Screw, 1/4-20 x 2.375
29	661-0001	Brake Assembly
—	737-0148	Grease (19 oz.)

*Use applicable flat washer (12a, 12b or 12c) in this application allowing .0150/.0020 in end-play

NOTE: *If rebuilding the upper housing of the transmission, add two ounces of Unirex[®] N3 grease (Part No. 737-0289) in the input shaft cavity.*

Models J609 & T609

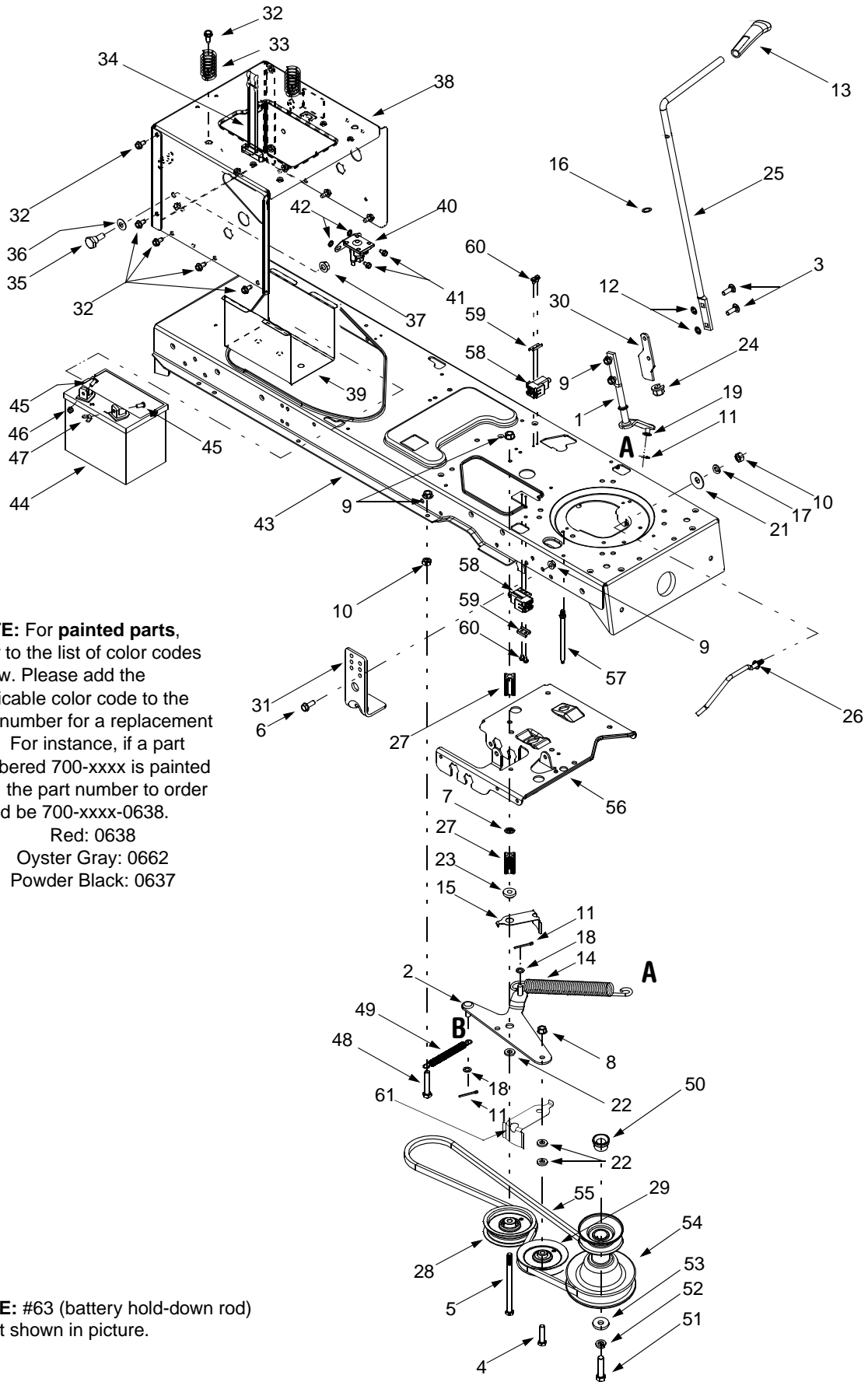

NOTE: For painted parts, refer to the list of color codes below. Please add the applicable color code to the part number for a replacement part. For instance, if a part numbered 700-xxxx is painted Red, the part number to order would be 700-xxxx-0638.

Red: 0638
 Oyster Gray: 0662
 Powder Black: 0637

NOTE: #63 (battery hold-down rod) is not shown in picture.

Models J609 & T609

Ref. No.	Part No.	Description	Ref. No.	Part No.	Description
1	647-0064	PTO Engage Lever Assembly	33	732-04035	Compression Spring, 1.28 x 3.125
2	683-0450	PTO Engage Plate Assembly	34	723-0444	Battery Strap
3	710-0276	Carriage Screw, 5/16-18 x 1.00	35	738-1020	Shoulder Screw, .625 x .5, 7/16-20
4	710-0520	Hex Cap Screw, 3/8-16 x 1.5	36	736-0407	Bell Washer, .45 x 1.0 x .062
5	710-0831	Hex Cap Screw, 3/8-16 x 5.5	37	712-0459	Flange Lock Nut, 7/16-20
6	710-0726	AB Screw 5/16-12 x 0.75	38	783-1031A	Hitch Plate
7	712-0229	Push Nut, 3/8	39	783-0349	Battery Tray
8	712-0431	Flange Lock Nut, 3/8-16	40	725-1426	Solenoid, 12-Volt, 100 Amp
9	712-3004A	Flange Lock Nut, 5/16-18	41	710-0599	Self Tapping Screw, 1/4-20 x .5
10	712-3010	Hex Nut, 5/16-18	42	736-0222	Lock Washer, 1/4
11	714-0470	Cotter Pin, 1/8 x 1.25	43	683-0304C	Lower Frame Assembly
12	726-0201	Speed Nut, .3125	44	725-1737A	12-volt Battery, 190 CCA (Model J609)
13	731-2111A	PTO Knob		725-1706A	12-volt Battery, 270 CCA (Model T609)
14	732-1170	Extension Spring, .75 x 6.75	45	710-0751	Hex Cap Screw, 1/4-20 x .62
15	732-0991A	Belt Guard	46	712-0271	Hex Sems Nut, 1/4-20
16	736-0108	Flat Washer, .510 x .750 x .033	47	712-3044	Wing Nut, 1/4-20
17	736-0119	Lock Washer, 5/16	48	732-1165	Extension Spring, .50 x 5.0
18	736-0140	Flat Washer, .385 x .62 x .063	49	710-3180	Hex Cap Screw, 5/16-18 x 1.75
19	736-0275	Flat Washer, 5/16	50	750-0596	Spacer Cup
20	736-3000	Flat Washer, .406 x .875 x .059	51	710-3029	Hex Head Cap Screw, 7/16-20 x 1.25
21	736-0242	Bell Washer	52	736-0171	Lock Washer, 7/16
22	736-3039	Flat Washer	53	736-0322	Flat Washer, .450 x 1.25
23	738-0372B	Shoulder Spacer, .380	54	756-0982B	Engine Pulley, 3.56 OD x 5.56
24	741-0708	Hex Split Flange Bearing, .5	55	754-0497	PTO Belt
25	747-1112D	PTO Engage Handle	56	783-0653F	Steering Support Bracket
26	747-1286A	Belt Keeper Rod	57	711-1044	Keeper Pin, 5/16 x 4.75
27	748-0415A	Spacer, 3/8 x 1.54	58	725-1657A	Switch
28	756-0627B	Idler Pulley, 3.5	59	17962	Switch Plate
29	756-1208	Idler Pulley, 4.0	60	710-0224	Screw, #10-16 x .5
30	783-0744A	Engagement Stop	61	732-1013	Belt Guard
31	783-0891B	Deck Stop	62	736-0300	Flat Washer
32	710-0604A	Self Tapping Screw, 5/16-18 x .625	63	747-04121A	Battery Hold-Down Rod (not shown)

Models J609

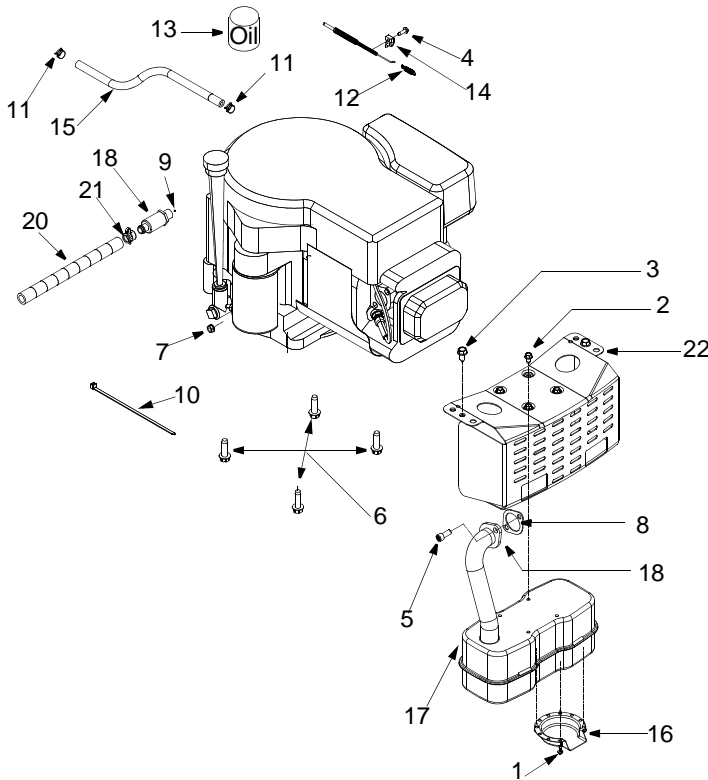

Ref. No.	Part No.	Description
1	710-0227	AB Screw #8-18 x 0.5
2	710-0599	TT Screw 1/4-20 x 0.5
3	710-0726	AB Screw 5/16-12 x 0.5
4	710-1237	T screw #10-32 x 0.625
5	710-1314A	Socket Hd Scr. 5/16-18 x .750
6	710-1315	TT Screw 3/8-16 x 1.25
7	712-0271	Sems Nut
8	721-0208	Exhaust Gasket
9	721-0331	Sealant: Loctite™
10	725-0157	Cable Tie
11	726-0205	Hose Clamp
12	732-0966	Extension Spring
13	737-0169	SAE 30W Oil
14	751B213146	Throttle Clamp
15	751-0535	Fuel Line Hose
16	751-0564A	Muffler Deflector
17	751-0617A	Muffler
18	751-0619A	Exhaust Pipe
19	751-3140	Oil Drain
20	751-3141	Oil Drain Hose Extension
21	751-3142	Oil Drain Cap
22	783-0615C	Muffler Bracket

Model T609

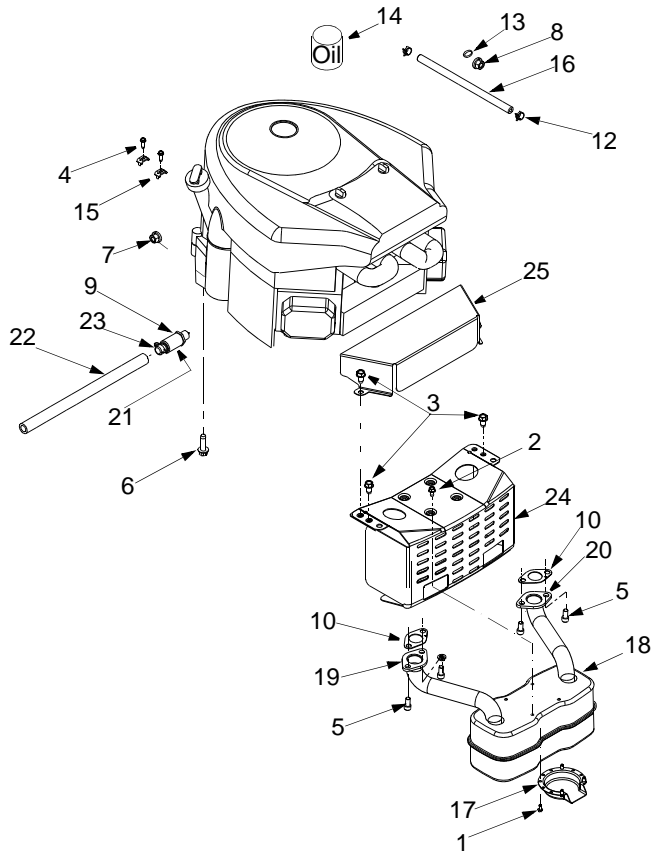

Ref. No.	Part No.	Description
1	710-0227	AB Screw 38-18 x 0.5
2	710-0599	TT Screw 1/4-20 x 0.5
3	710-0726	AB Screw 5/16-20 x 0.75
4	710-1237	T Screw #10-32 x 0.625
5	710-1314A	Socket Hd. Scr. 5/16-18 x 0.75
6	710-1315	TT Screw 3/8-16 x 1.25
7	712-0271	Sems Nut
8	712-3017	Hex Nut
9	721-0331	Pipe Sealant
10	721-0460	Exhaust Gasket
11	725-0157	Cable Tie(not shown)
12	726-0205	Hose Clamp
13	736-0300	Flat Washer
14	737-0169	Oil: SAE 30W
15	751B221535	Clamp: Casing
16	751-0535	Fuel Line Hose
17	751-0564A	Deflector: Muffler
18	751-0616A	Dual Inlet Muffler
19	751-0650A	Exhaust Pipe RH
20	751-0651A	Exhaust Pipe LH
21	751-3140	Oil Drain
22	751-3141	Extension Hose: Oil Drain
23	751-3142	Oil Drain Cap
24	783-0615B	Heat Shield: Muffler
25	783-0625C	Heat Shield: Single

Models J609 & T609

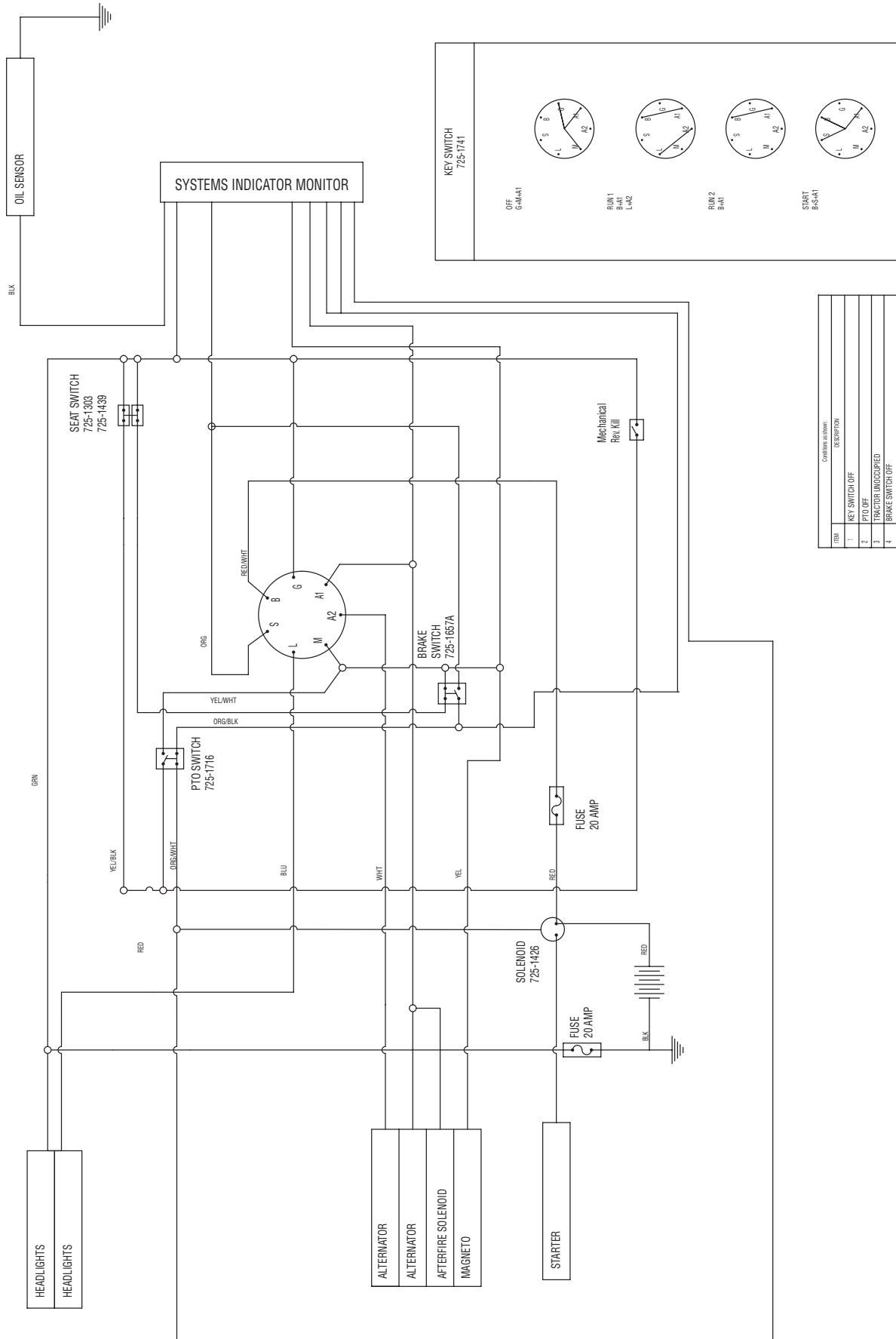

Models J609 & T609

NOTE: For painted parts, refer to the list of color codes below. Please add the applicable color code to the part number for a replacement part. For instance, if a part numbered 700-xxxx is painted Red, the part number to order would be 700-xxxx-0638.

Red: 0638
Oyster Gray: 0662
Powder Black: 0637

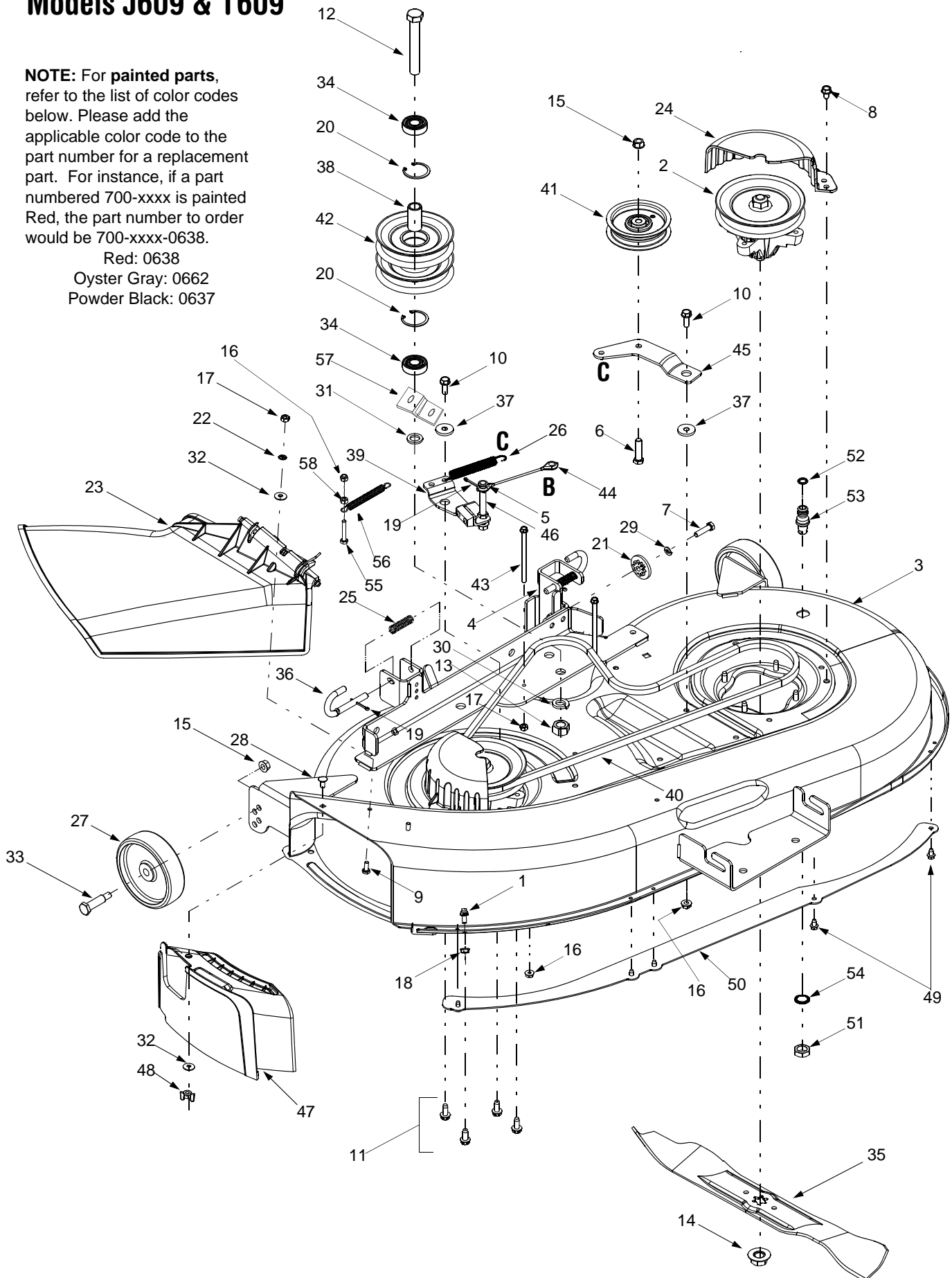

Models J609 & T609

Ref. No.	Part No.	Description	Ref. No.	Part No.	Description
1	711-04069	Grass Catcher Pin, 1/4-20	31	736-0162	Flat Washer, .64 x 1.0 x .12
2	618-0565	Spindle Assy., 5.75 Dia. w/ Fitting	32	736-0270	Bell Washer, .265 x .75 x .062
3	683-0198G	42-inch Deck Shell	33	738-0373	Shoulder Screw, .498 x 1.53
4	683-0254	Deck Adj. Bracket w/ Weld Nut	34	741-0524	Bearing, .625 x 1.574 x .470
5	736-0140	Flat Washer, .385 x .62 x .063	35	742-0616A	Blade, Star Center, 21.23"
6	710-0520	Hex Cap Screw, 1/4-20 x 1.5	36	747-1116	Deck Release Pin
7	710-0528	Hex Cap Screw, 5/16-18 x 1.25	37	748-0331	Shoulder Spacer, .625 x .324
8	710-0726	Self-tapping Screw, 5/16-12 x .75	38	750-0932A	Spacer, .635 x .88 x 1.72
9	710-0751	Hex Cap Screw, 1/4-20 x .62	39	683-0440	Deck Brake Assembly
10	710-1238	Hex Hd. Washer Scr., 5/16-18 x .875	40	754-0498	Deck Belt
11	710-0650	Self-tapping Screw, 5/16-18 x .875	41	756-0627B	Idler Pulley, 3.5
12	710-3151	Hex Cap Screw, 5/8-18 x .875	42	756-1202	Double Pulley, 5.0
13	712-0337	Hex Nut, 5/8-18	43	710-1830	Self-tapping Screw, 1/4-20 x 4.0
14	712-0417A	Hex Flange Nut, 5/8-18	44	746-0970	Brake Cable, 5.05
15	712-0431	Flange Lock Nut, 3/8-16	45	783-1291	Idler Bracket
16	712-0429	Flange Lock Nut, 5/16-18	46	711-1534	Pin, 3/8-16, 3/8 x 3.27
17	712-3006	Hex Nut, 1/4-20	47	731-2363	Mulch Plug
18	712-0324	Hex Lock Nut, 3/8-16	48	712-3087	Wing Nut
19	714-0470	Cotter Pin, 1/8 x 1.25	49	710-0599	Self-Tapping Screw, 1/4-20 x .5
20	716-3020	Internal Snap Ring	50	783-1146A	Deck Skirt
21	717-04074	Deck Adjustment Gear	51	712-0641	Hex Nut, M-16 x 1.5
22	726-0233	Push Nut. .25 x .5	52	721-0417	O-Ring
23	731-1032B	Side Discharge Chute Assembly	53	737-04003B	Water Nozzle (if equipped)
24	731-2486A	Belt Cover	54	736-0760	Lock Washer
25	732-0306A	Comp. Spring, .406 x .531 x 1.75	55	710-3180	Hex Bolt, 5/16-18 x 1.75
26	732-0470A	Extension Spring, .50 x 4.74	56	732-1165	Extension Spring
27	734-0973	Deck Wheel, 5 x 1.38	57	783-04013A	Stab. Bracket: Pulley
28	710-0134	Carriage Screw, 1/4-20 x .5	58	712-3010	Hex Nut
29	736-0119	Lock Washer, 5/16	59	783-1025	Chute Stop (not shown)
30	736-0158	Lock Washer, 5/8			

MANUFACTURER'S LIMITED WARRANTY FOR:



The limited warranty set forth below is given by Troy-Bilt LLC with respect to new merchandise purchased and used in the United States, its possessions and territories.

"Troy-Bilt" warrants this product against defects in material and workmanship for a period of two (2) years commencing on the date of original purchase and will, at its option, repair or replace, free of charge, any part found to be defective in materials or workmanship. This limited warranty shall only apply if this product has been operated and maintained in accordance with the Operator's Manual furnished with the product, and has not been subject to misuse, abuse, commercial use, neglect, accident, improper maintenance, alteration, vandalism, theft, fire, water, or damage because of other peril or natural disaster. Damage resulting from the installation or use of any part, accessory or attachment not approved by Troy-Bilt for use with the product(s) covered by this manual will void your warranty as to any resulting damage.

Normal wear parts or components thereof are subject to separate terms as follows: All normal wear parts or component failures will be covered on the product for a period of 30 days regardless of cause. After 30 days, but within the two year period, normal wear part failures will be covered ONLY IF caused by defects in materials or workmanship of OTHER component parts. Normal wear parts and components include, but are not limited to: batteries, belts, blades, blade adapters, grass bags, rider deck wheels, seats, snow thrower skid shoes, shave plates, auger spiral rubber, and tires.

HOW TO OBTAIN SERVICE: Warranty service is available, WITH PROOF OF PURCHASE, through your local authorized service dealer. To locate the dealer in your area, check your Yellow Pages, or contact Troy-Bilt LLC at P.O. Box 361131, Cleveland, Ohio 44136-0019, or call 1-866-840-6483 or 1-330-558-7220, or log on to our Web site at www.troybilt.com.

This limited warranty does not provide coverage in the following cases:

- a. Engine or components thereof. These items may carry a separate manufacturer's warranty. Refer to applicable manufacturer's warranty for terms and conditions.
- b. Log splitter pumps, valves, and cylinders have a separate one year warranty.
- c. Routine maintenance items such as lubricants, filters, blade sharpening, tune-ups, brake adjustments, clutch adjustments, deck adjustments, and normal deterioration of the exterior finish due to use or exposure.

- d. Troy-Bilt does not extend any warranty for products sold or exported outside of the United States, its possessions and territories, except those sold through Troy-Bilt's authorized channels of export distribution.
- e. Replacement parts that are not genuine Troy-Bilt parts.
- f. Service completed by someone other than an authorized service dealer.
- g. Transportation charges and service calls.

No implied warranty, including any implied warranty of merchantability of fitness for a particular purpose, applies after the applicable period of express written warranty above as to the parts as identified. No other express warranty, whether written or oral, except as mentioned above, given by any person or entity, including a dealer or retailer, with respect to any product, shall bind Troy-Bilt. During the period of the warranty, the exclusive remedy is repair or replacement of the product as set forth above.

The provisions as set forth in this warranty provide the sole and exclusive remedy arising from the sale. Troy-Bilt shall not be liable for incidental or consequential loss or damage including, without limitation, expenses incurred for substitute or replacement lawn care services or for rental expenses to temporarily replace a warranted product.

Some states do not allow the exclusion or limitation of incidental or consequential damages, or limitations on how long an implied warranty lasts, so the above exclusions or limitations may not apply to you.

In no event shall recovery of any kind be greater than the amount of the purchase price of the product sold. **Alteration of safety features of the product shall void this warranty.** You assume the risk and liability for loss, damage, or injury to you and your property and/or to others and their property arising out of the misuse or inability to use the product.

This limited warranty shall not extend to anyone other than the original purchaser or to the person for whom it was purchased as a gift.

HOW STATE LAW RELATES TO THIS WARRANTY: This limited warranty gives you specific legal rights, and you may also have other rights which vary from state to state.

IMPORTANT: Owner must present Original Proof of Purchase to obtain warranty coverage.

Troy-Bilt LLC, P.O. BOX 361131 CLEVELAND, OHIO 44136-0019; Phone: 1-866-840-6483, 1-330-558-7220

Free Manuals Download Website

<http://myh66.com>

<http://usermanuals.us>

<http://www.somanuals.com>

<http://www.4manuals.cc>

<http://www.manual-lib.com>

<http://www.404manual.com>

<http://www.luxmanual.com>

<http://aubethermostatmanual.com>

Golf course search by state

<http://golfingnear.com>

Email search by domain

<http://emailbydomain.com>

Auto manuals search

<http://auto.somanuals.com>

TV manuals search

<http://tv.somanuals.com>