

# GARDEN WAY

*by* **TROY-BILT™**

## Owner's Manual

### REAR-TINE TILLERS

- **Safety**
- **Assembly**
- **Controls**
- **Operation**
- **Maintenance**
- **Parts List**

#### Models

12214 – 5.5HP

12193 – 6.5HP



Dear Owner:

You now own one of the finest counter-rotating-tine (CRT) tillers available. Your tiller provides excellent sod busting and seedbed preparation, making it ideal for starting new gardens and for a variety of landscaping jobs. Your tiller is well-known for its ruggedness, performance and high-quality engineering. We know you'll enjoy using it.

Please carefully read this Manual. It tells you how to safely and easily assemble, operate and maintain your machine. *Be sure that you and any other operators carefully follow the recommended safety practices at all times. Failure to do so could result in personal injury or property damage.*

Of course, if you should ever have any problems or questions, please contact your local authorized dealer or call the Factory (see back cover of this manual). We want to be sure that you are completely satisfied at all times.

NOTE: Be sure to fill out and return the Warranty Registration Card that was supplied with this Manual.

---

### See Back Cover for Customer Service Information

---

#### Safety Alert Symbol



This is a safety alert symbol. It is used in this manual and on the unit to alert you to potential hazards. When you see this symbol, read and obey the message that follows it. Failure to obey safety messages could result in personal injury or property damage.

This machine meets voluntary safety standard B71.8 – 1996, which is sponsored by the Outdoor Power Equipment Institute, Inc., and is published by the American National Standards Institute.

### **WARNING**

The engine exhaust from this product contains chemicals known to the State of California to cause cancer, birth defects or other reproductive harm.

## Table of Contents

<b>SECTION 1: SAFETY</b> .....	<b>3</b>
Safety Decals .....	5
<b>SECTION 2: ASSEMBLY</b> .....	<b>6</b>
Attach Handlebar .....	7
Move Tiller Off Shipping Platform.....	7
Install Forward Clutch Cable .....	8
Install Reverse Clutch Cable .....	9
Check Level of Transmission Gear Oil.....	9
Add Motor Oil to Engine.....	9
Check Hardware for Tightness.....	9
Check Air Pressure in Tires.....	9
<b>SECTION 3: FEATURES &amp; CONTROLS</b> .....	<b>10</b>
Wheel Drive Pins .....	10
Forward Clutch Bail.....	11
Reverse Clutch Control .....	11
Depth Regulator Lever .....	12
Handlebar Height Adjustment .....	12
Anti-Reverse Stake .....	12
Engine Controls .....	12
<b>SECTION 4: OPERATION</b> .....	<b>13</b>
Break-In Operation.....	13
Starting and Stopping the Engine .....	13
Operating the Tiller .....	14
Loading and Unloading the Tiller .....	15
Tilling Tips & Techniques .....	16
<b>SECTION 5: MAINTENANCE</b> .....	<b>18</b>
Required Maintenance Schedule.....	18
Tiller Lubrication.....	19
Check for Oil Leaks .....	19
Check Hardware.....	19
Check Tire Pressure.....	19
Transmission Gear Oil Service.....	19
Tines.....	20
Checking and Adjusting Forward Drive Belt Tension.....	20
Forward Clutch Bail Adjustment.....	21
Checking and Adjusting Reverse Drive Belt Tension .....	22
Engine Cleaning .....	22
Air Cleaner Service.....	22
Engine Oil Service.....	23
Spark Plug Service.....	23
Spark Arrester Screen Service .....	23
Carburetor/Governor Control Adjustments .....	23
Throttle Lever Adjustment .....	23
Off Season Storage.....	23
Troubleshooting.....	24
<b>PARTS LIST</b> .....	<b>25</b>
<b>CUSTOMER SERVICE INFORMATION</b> .....	<b>Back Cover</b>

# Section 1 Safety

## SPARK ARRESTER WARNING TO RESIDENTS OF CALIFORNIA AND SEVERAL OTHER STATES

Under California law, and under the laws of several other states, you are not permitted to operate an internal combustion engine using hydrocarbon fuels on any forest, brush, hay, grain, or grass covered land; or land covered by any flammable agricultural crop without an engine spark arrester in continuous effective working order.



The engine on the unit is an internal combustion engine which burns gasoline, a hydrocarbon fuel, and must be equipped with a spark arrester muffler in continuous effective working order. The spark arrester must be attached to the engine exhaust system in such a manner that flames or heat from the system will not ignite flammable material. Failure of the owner/operator of the unit to comply with this regulation is a misdemeanor under California law (and other states) and may also be a violation of other state and/or federal regulations, laws, ordinances or codes. Contact your local fire marshal or forest service for specific information about which regulations apply in your area.

### Training

1. Carefully read this Owner's Manual, the separate Engine Owner's Manual, and any other literature you may receive. Be thoroughly familiar with the controls and the proper use of the tiller and its engine. Know how to stop the unit and disengage the controls quickly.



2. Never allow children to operate the tiller. Never allow adults to operate the tiller without proper instruction.
3. Keep the area of operation clear of all persons, particularly children and pets.
4. Keep in mind that the operator or user is responsible for accidents or hazards occurring to other people, their property, and themselves.

### Preparation

1. Thoroughly inspect the area where the tiller is to be used and remove all foreign objects.
2. Be sure all tiller controls are released and both wheels are in the Wheel Drive position before starting the engine.
3. Do not operate the tiller without wearing adequate outer garments. Avoid loose garments or jewelry that could get caught in moving parts.
4. Do not operate the tiller when barefoot or wearing sandals, sneakers, or light footwear. Wear protective footwear that will improve footing on slippery surfaces.

5. Do not till near underground electric cables, telephone lines, pipes or hoses. If in doubt, contact your telephone or utility company.

6. Warning: Handle fuel with care; it is highly flammable and its vapors are explosive. Be sure to take the following precautions:

- a. Store fuel in containers specifically designed for this purpose.
  - b. The gas cap shall never be removed or fuel added while the engine is running. Allow the engine to cool for several minutes before adding fuel.
  - c. Keep matches, cigarettes, cigars, pipes, open flames, and sparks away from the fuel tank and fuel container.
  - d. Fill fuel tank outdoors with extreme care. Never fill fuel tank indoors. Use a funnel or spout to prevent spillage.
  - e. Replace all fuel tank and container caps securely.
  - f. If fuel is spilled, do not attempt to start the engine, but move the machine away from the area of spillage and avoid creating any source of ignition until fuel vapors have dissipated.
7. Never make adjustments when engine is running (unless recommended by manufacturer).

### Operation

1. Do not put hands or feet near or under rotating parts. The tines begin to rotate backward once the engine starts and the Forward Clutch Bail or the Reverse Clutch Control is engaged.
2. Exercise extreme caution when on or crossing gravel drives, walks, or roads. Stay alert for hidden hazards or traffic. Do not carry passengers.
3. After striking a foreign object, stop the engine, remove the wire from the spark plug and prevent it from touching the spark plug, thoroughly inspect the machine for any damage, and repair the damage before restarting and operating the machine.
4. Exercise caution to avoid slipping or falling.
5. If the unit should start to vibrate abnormally, stop the engine, disconnect the spark plug wire and prevent it from touching the spark plug, and check immediately for the cause. Vibration is generally a warning of trouble.
6. Stop the engine, disconnect the spark plug wire and prevent it from touching the spark plug whenever you leave the operating position, before unclogging the tines, or when making any repairs, adjustments or inspections.

## Section 1: Safety

---

7. Take all possible precautions when leaving the machine unattended. Stop the engine. Disconnect spark plug wire and move it away from the spark plug. Be sure both wheels are in the Wheel Drive position.

8. Before cleaning, repairing, or inspecting, stop the engine and make certain all moving parts have stopped. Disconnect the spark plug wire and prevent it from touching the spark plug to prevent accidental starting.

9. The flap on the tine hood must be down when operating the tiller.

10. Never use the tiller unless proper guards, plates, or other safety protective devices are in place.

11. Do not run engine in an enclosed area. Engine exhaust contains carbon monoxide gas, a deadly poison that is odorless, colorless, and tasteless.

12. Keep children and pets away.

13. **Never operate the tiller under engine power if the wheels are in the Freewheel position. In the Freewheel position, the wheels will not hold the tiller back and the revolving tines could propel the tiller rapidly, possibly causing loss of control.** Always engage the wheels with the wheel drive pins in the Wheel Drive position before starting the engine or engaging the tines/wheels with the Forward Clutch Bail or the Reverse Clutch Control.

14. **Be aware that the tiller may unexpectedly bounce upward or jump backward and be propelled toward you if the tines should strike extremely hard packed soil, frozen ground, or buried obstacles like large stones, roots, or stumps. If in doubt about the tilling conditions, always use the following operating precautions to assist you in maintaining control of the tiller:**

- a. **Walk behind and to one side of the tiller, using one hand on the handlebars. Relax your arm, but use a secure hand grip.**
- b. **Use a deep depth regulator setting.**
- c. **Use slower engine speeds.**

d. **Clear the tilling area of all large stones, roots and other debris.**

e. **Avoid using downward pressure on handlebars. If need be, use slight upward pressure to keep the tines from digging too deeply.**

f. **Before contacting hard packed soil at the end of a row, reduce engine speed and lift handlebars to raise tines out of the soil.**

g. **In an emergency, stop tines and wheels by releasing whichever clutch control is engaged. Do not attempt to restrain the tiller.**

15. Do not overload the tiller's capacity by attempting to till too deeply at too fast a rate.

16. Never operate the tiller at high transport speeds on slippery surfaces. Look behind and use great care when backing up.

17. Do not operate the tiller on a slope that is too steep for safety. When on slopes, slow down and make sure you have good footing. Never permit the tiller to freewheel down slopes.

18. Never allow bystanders near the unit.

19. Only use attachments and accessories that are approved by the manufacturer of the tiller.

20. Use tiller attachments and accessories when recommended.

21. Never operate the tiller without good visibility or light.

22. Never operate the tiller if you are tired, or under the influence of alcohol, drugs or medication.

23. Operators shall not tamper with the engine-governor settings on the machine; the governor controls the maximum safe operating speed to protect the engine and all moving parts from damage caused by overspeed. Authorized service shall be sought if a problem exists.

24. Do not touch engine parts which may be hot from operation. Let parts cool down sufficiently.

25. Please remember: You can always stop the tines and wheels by releasing the Forward Clutch Bail or the Reverse Clutch Control (whichever control is engaged), or by moving the ignition switch and/or throttle control lever on the engine to "OFF" or "STOP".

26. To load or unload the tiller, see the instructions in Section 4 of this Manual.

27. Use extreme caution when reversing or pulling the machine towards you.

28. Start the engine carefully according to instructions and with feet well away from the tines.

29. Never pick up or carry a machine while the engine is running.

## Maintenance and Storage

1. Keep the tiller, attachments and accessories in safe working condition.

2. Check all nuts, bolts, and screws at frequent intervals for proper tightness to be sure the equipment is in safe working condition.

3. Never store the tiller with fuel in the fuel tank inside a building where ignition sources are present such as hot water and space heaters, furnaces, clothes dryers, stoves, electric motors, etc.). Allow engine to cool before storing in any enclosure.

4. To reduce the chances of a fire hazard, keep the engine free of grass, leaves, or excessive grease.

5. Store gasoline in a cool, well-ventilated area, safely away from any spark- or flame-producing equipment. Store gasoline in an approved container, safely away from the reach of children.

6. Refer to the Maintenance sections of this Manual and the separate Engine Owner's Manual for instructions if the tiller is to be stored for an extended period.

7. Never perform maintenance while the engine is running or the spark plug wire is connected, except when specifically instructed to do so.

8. If the fuel tank has to be drained, do this outdoors.

## Decals

For your safety and the safety of others, various safety and operational decals are located on your unit (see Figure 1 below).

Keep the decals clean and legible at all times. Contact your local service dealer or the factory for replacements if any decals are damaged or missing.

Refer to the Parts List at the back of this Manual for decal locations, descriptions and part numbers.

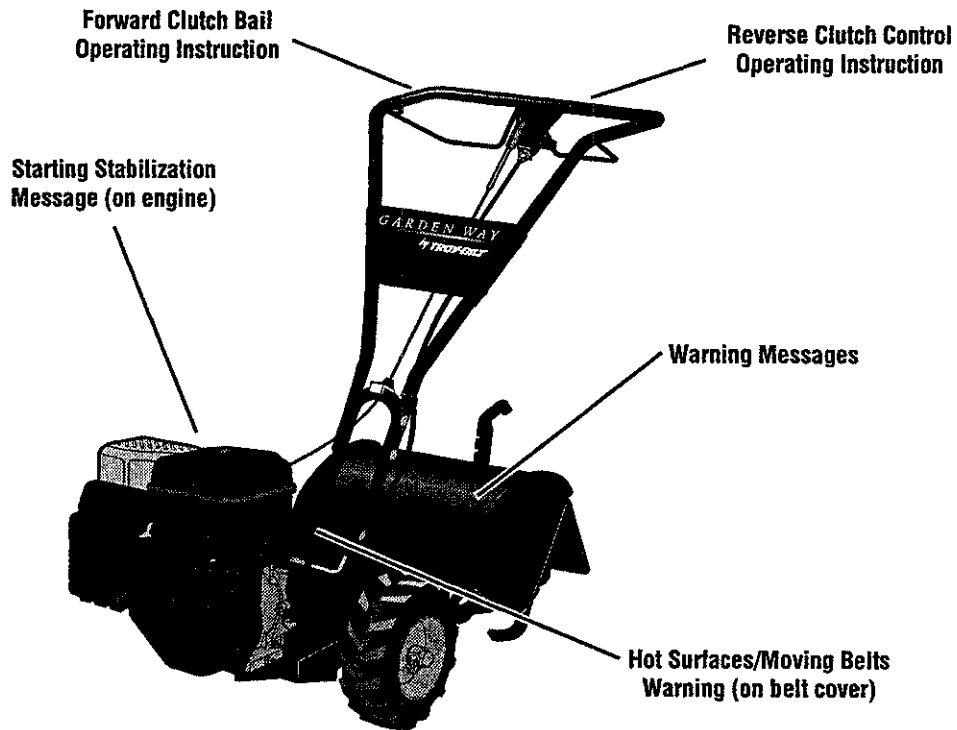

Figure 1: Location of Safety and Operating Decals.

### Operating Symbols

Various symbols (shown here, with word descriptions) are used on the tiller and engine (your unit may not have all of the symbols).



### ! WARNING

#### TO AVOID SERIOUS INJURY:

- READ THE OWNER'S MANUAL.
- KNOW LOCATIONS AND FUNCTIONS OF ALL CONTROLS.
- KEEP ALL SAFETY DEVICES AND SHIELDS IN PLACE AND WORKING.
- NEVER ALLOW CHILDREN OR UNINSTRUCTED ADULTS TO OPERATE TILLER.
- SHUT OFF ENGINE AND DISCONNECT SPARK PLUG WIRE BEFORE MANUALLY UNCLOGGING TINES OR MAKING REPAIRS.
- KEEP BYSTANDERS AWAY FROM MACHINE.
- KEEP AWAY FROM ROTATING PARTS.
- USE EXTREME CAUTION WHEN REVERSING OR PULLING THE MACHINE TOWARDS YOU.

# Section 2 Assembly

## ⚠ WARNING

To prevent personal injury or property damage, do not start the engine until all assembly steps are complete and you have read and understand the safety and operating instructions in this manual.

### Introduction

Carefully follow these assembly steps to correctly prepare your tiller for use. It is recommended that you read this Section in its entirety before beginning assembly. NOTE: If an assembly step applies only to certain models, those models are noted at the beginning of that step. Otherwise, a step applies to all models.

### Inspect unit

Inspect the unit and carton for damage immediately after delivery. Contact the carrier (trucking company) if you find or suspect damage. Inform them of the damage and request instructions for filing a claim. To protect your rights, put your claim in writing and mail a copy to the carrier within 15 days after the unit has been delivered. Contact us at the factory if you need assistance in this matter.

### STEP 1: Unpacking Instructions

NOTE: Be careful not to severely bend any of the control cables on the unit.

1. Remove any cardboard inserts and packaging material from the carton. Remove any staples from the bottom of the carton and remove the carton.
2. The tiller is heavy (approximately 133 lbs.). Do not attempt to remove it from the shipping platform until instructed to do so in these "Assembly" steps.

3. Remove all unassembled parts and the separate hardware bag from the carton. Check that you have the items listed below (contact your local dealer or the factory if any items are missing or damaged). NOTE: Use the screw length template (Fig. 2-1) to identify screws.

#### Loose Parts List

Qty.	Description
1	Handlebar Support (see A, Fig. 2-2, page 7)
1	Handlebar Assembly (see K, Fig. 2-2)
<i>The following items are in the hardware bag:</i>	
1	Slotted hd. screw, #10-24 x 2"
1	Hex hd. screw, 1/4-20 x 1-1/4"
6	Hex hd. screw, 5/16-18 x 1-1/2"
2	Hex hd. screw, 3/8-16 x 3/4"
2	Flat washer, 3/8"
6	Split lockwasher, 5/16"
1	Hex locknut, 1/4"-20
6	Hex nut, 5/16"-18
2	Hex locknut, 3/8"-16
1	Hex nut, #10-24
1	Spring, cable (see W, Fig. 2-5, page 8)
1	Bracket, forward clutch cable (see P, Fig. 2-4, page 8)
1	Bracket, reverse clutch cable (see BB, Fig. 2-8, page 9).

**IMPORTANT:** Motor oil must be added to the engine crankcase before the engine is started. Follow the instructions in this "Assembly" section.

NOTE: LEFT and RIGHT sides of the tiller are as viewed from the operator's position behind the handlebars.

### Tools/Materials Needed for Assembly

- (1) 3/8" open-end wrench\*
- (2) 7/16" open-end wrench\*
- (1) 1/2" open-end wrench\*
- (2) 9/16" open-end wrench\*
- (1) Large adjustable wrench
- (1) Scissors (to trim plastic ties)
- (1) Ruler (for belt tension check)
- (1) Block of wood (to support tiller when removing wheels)
- (1) Automotive-type air pressure gauge (for models with pneumatic tires)
- (1) Clean oil funnel
- (1) Clean, high-quality motor oil. Refer to the Engine Owner's Manual for motor oil specifications and quantity required.

\* Adjustable wrenches may be used.

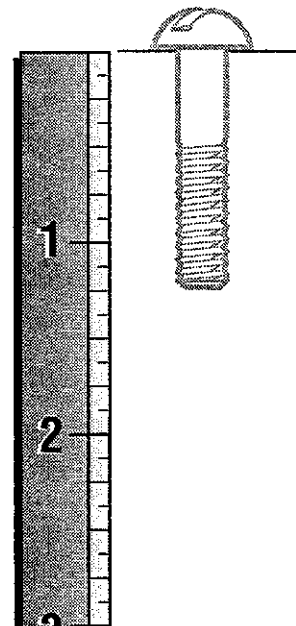

Figure 2-1: To identify length of screw, place screw on template as shown and measure distance between bottom of screw head and tip of screw.

## STEP 2: Attach Handlebar

1. Attach the two legs of the handlebar support (A, Fig. 2-2) loosely to the inner sides of the tiller frame using two 3/8"-16 x 3/4" hex hd. screws (B), 3/8" flat washers (C) and 3/8"-16 hex locknuts (D).
2. There are three height adjustment holes in the two handlebar support brackets (E and F, Fig. 2-2). Choose a setting that will position the handlebars at approximately waist level when the tines are 3"-4" into the soil. Loosely attach the support brackets to the handlebar support (A) using two 5/16"-18 x 1-1/2" screws (G), 5/16" split lockwashers (H) and 5/16"-18 hex nuts (I). NOTE: If a support bracket will not move, loosen attaching screw (J) and nut.
3. Attach the handlebar assembly (K) to the handlebar support (A) using four 5/16"-18 x 1-1/2" screws (G), 5/16" split lockwashers (H) and 5/16"-18 hex nuts (I). Tighten the four screws securely.
4. Tighten all handlebar mounting hardware securely.

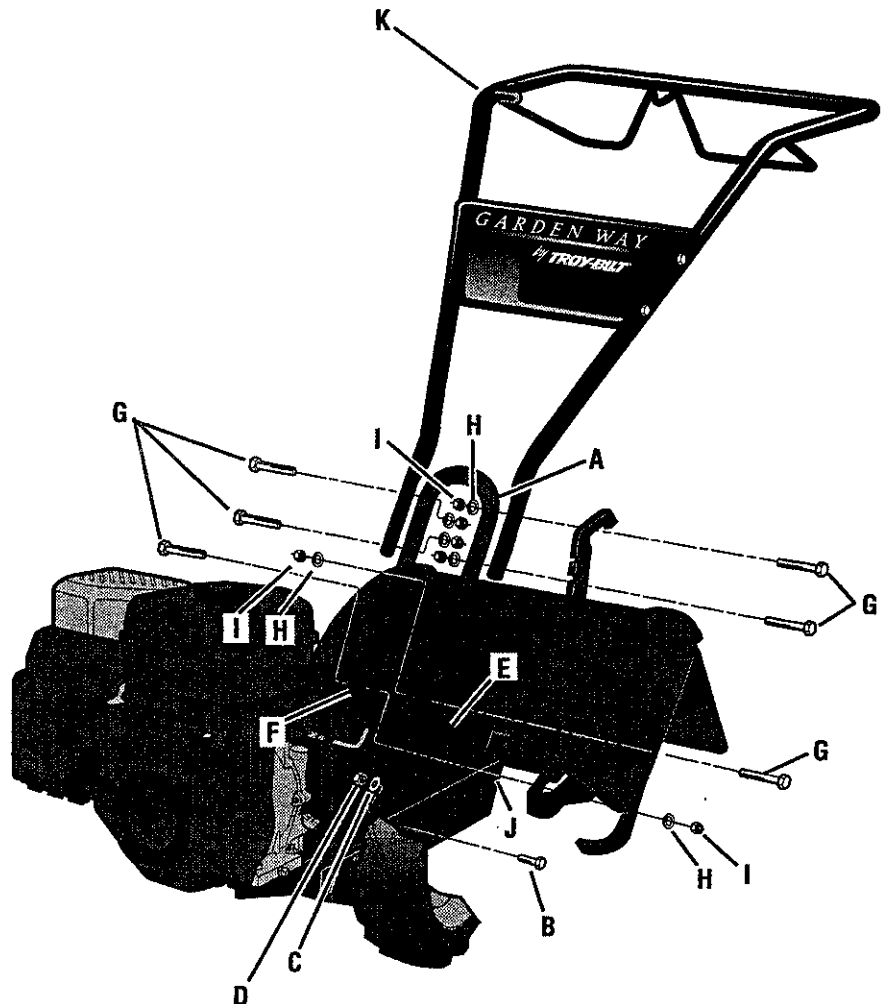

Fig. 2-2: Attach handlebar.

## STEP 3: Move Tiller Off Shipping Platform

To move the tiller without the engine running, put the wheels in their FREEWHEEL position, as described below.

1. Use a sturdy block to raise one wheel off the ground.
2. Remove the hairpin cotter (L, Fig. 2-3) and wheel drive pin (M). Slide the wheel inward on the wheel shaft (N). Reinstall the wheel drive pin through the wheel shaft only (not through the wheel hub) and secure it with the hairpin cotter (push hairpin cotter in as far as it will go). Repeat with the other wheel.
3. Using the handlebar as a lever, roll the tiller to a flat area.

**IMPORTANT:** Before starting the engine, the wheels must be placed in their WHEEL DRIVE position (pins through wheel hubs and wheel shaft). This procedure is described in "Wheel Drive Pins" in Section 3.

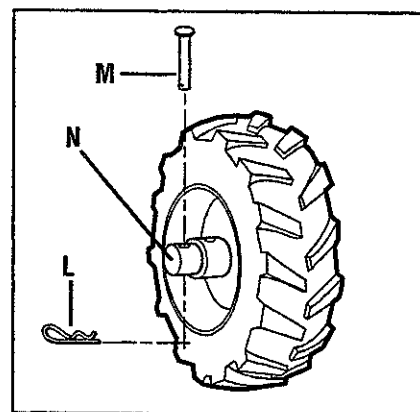

Fig. 2-3: Wheel in FREEWHEELING position (wheel drive pin through wheel shaft only).

## Section 2: Assembly

### STEP 4: Install Forward Clutch Cable

1. Attach the forward clutch cable bracket (P, Fig. 2-4) to the handlebar support (A) with a 1/4"-20 x 1-1/4" hex hd. screw (R, Fig. 2-4) and 1/4"-20 hex locknut (S). Tighten securely.

2. Carefully unwrap the forward clutch cable (cable without a knob) from its shipping position and slide the thin cable wire (T, Fig. 2-4) into the slot in the cable bracket. Push the cable connector (U, Fig. 2-4) up through the hole in the bracket until the groove in the connector snaps into place.

3. Insert the #10-24 x 2" slotted hd. screw (V, Fig. 2-5) into the cable spring (W) until the screw threads extend through the spring.

4. Thread the #10-24 hex nut (Z, Fig. 2-5) halfway onto the screw (V).

5. Thread the screw into the cable adjuster (X).

6. Hook the cable spring (W, Fig. 2-6) into the "V"-shaped bend in the Forward Clutch Bail (Y).

7. Check for correct tension on the forward drive belt by taking two measurements of the cable spring, as follows:

- With the Forward Clutch Bail (Y, Fig. 2-6) in an open (released) position, measure the length of the cable spring (W) from the outermost coil to the outermost coil.
- Lift and hold the Forward Clutch Bail against the handlebar (see Fig. 2-7) and re-measure the length of the coils while the spring is under tension. The belt tension is correct if this second measurement is between 1/16" -to- 3/16" longer than the first measurement. If so, turn the hex nut (Z, Fig. 2-7) tightly against the cable adjuster (X) while preventing the adjuster from turning.
- If the spring length is incorrect, you must adjust the cable tension as described in "Checking and Adjusting Forward Drive Belt Tension" in Section 5. Incorrect tension on the forward drive belt can result in belt slippage (tension too loose) or unintentional fine movement when the clutch bail is in Neutral (tension too tight).

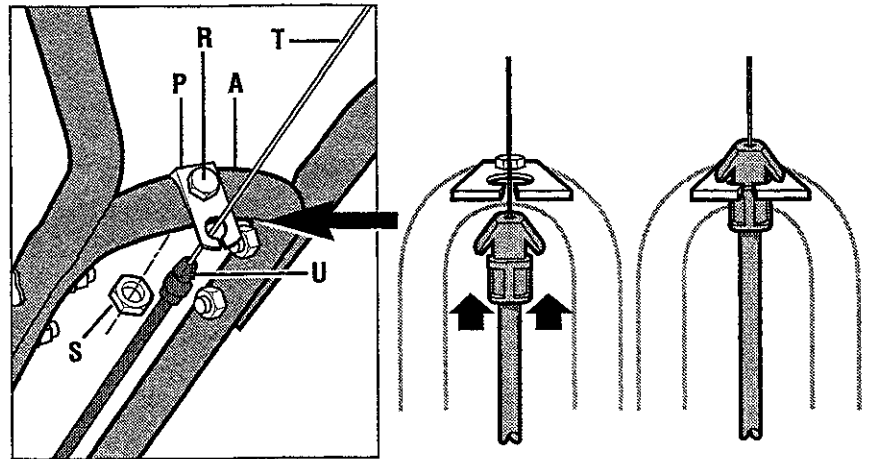

Fig. 2-4: Installing forward clutch cable bracket and cable.

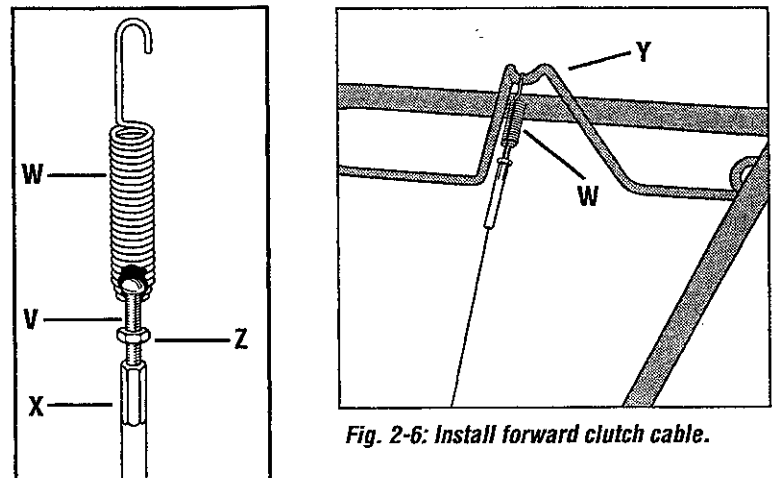

Fig. 2-5: Assemble spring and adjuster.

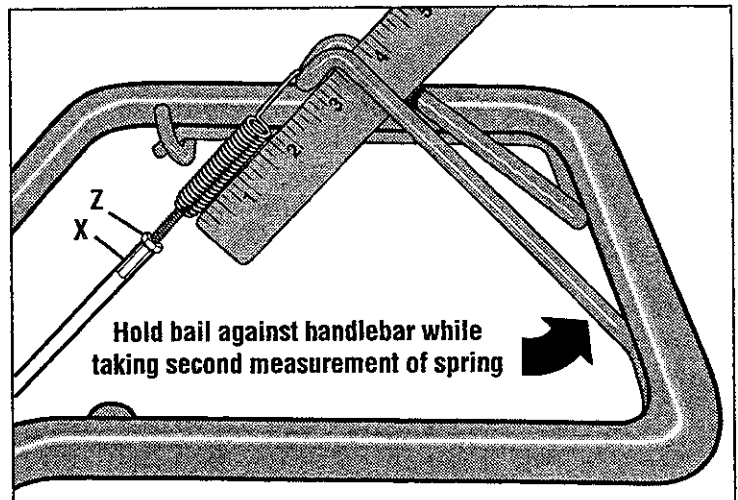

Fig. 2-7: To check forward belt tension, take two measurements of the overall length of the coils in the spring – first with the clutch bail open, then with the clutch bail closed against the handlebar.



### STEP 5: Install Reverse Clutch Cable

1. Remove the two pre-installed self-tapping screws (AA, Fig. 2-8) from the handlebars.
2. Position the reverse cable mounting bracket (BB, Fig. 2-8) as shown and reinstall the two self-tapping screws.
3. Unwrap the reverse clutch cable (cable with a knob and a large nut attached to it) from around its shipping position and route the cable (CC, Fig. 2-8 and Fig. 2-9) up to the cable bracket (BB, Fig. 2-8). Be sure that the cable is routed beneath the Forward Clutch Bail.
4. Insert the cable through the slot in the cable bracket and position the threaded assembly as shown in Fig. 2-8. Make sure that the flat side of the threaded assembly is aligned with the flat side of the mounting hole. Slide the large hex nut (DD) up the cable and tighten it securely.

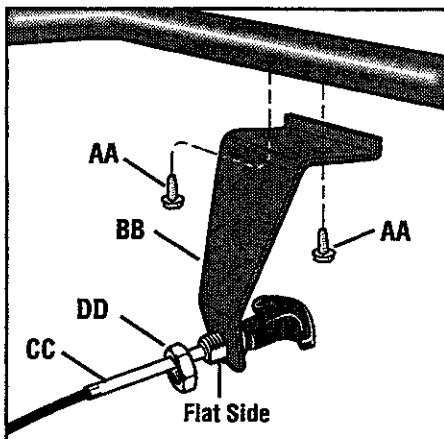

Fig. 2-8: Install reverse cable mounting bracket and the reverse clutch cable.

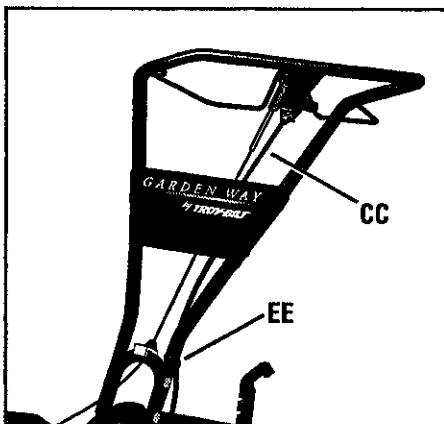

Fig. 2-9: Route reverse clutch cable (CC) as shown. Attach to handlebar with cable tie (EE).

5. Use a cable tie (EE, Fig. 2-9) to fasten the reverse clutch cable to the left side handlebar.
6. Test the function of the reverse clutch cable by pulling the knob out and releasing it. The knob should return to its neutral position (resting against bracket) when it is released. If it doesn't, contact your local dealer or the factory for technical assistance.

### STEP 6: Check Level of Transmission Gear Oil

The transmission was filled with gear oil at the factory. However, you should check the gear oil level to make certain it is correct.

**IMPORTANT:** Do not operate the tiller if the gear oil level is low. Doing so will result in severe damage to the transmission components.

1. With the tiller on level ground, pull the Depth Regulator Lever (FF, Fig. 2-10) back and then move it up or down until the tiller is level.
2. Remove the oil fill plug (GG, Fig. 2-11) from the transmission housing and look into the oil fill hole. You will see the main drive shaft on one side of the hole.
3. The gear oil level is correct if the gear oil is approximately halfway up the side of the drive shaft.
4. If the gear oil level is low, add gear oil by referring to "A. To Check the Transmission Gear Oil Level" in Section 5.

### STEP 7: Add Motor Oil to Engine

The tiller is shipped *without* oil in the engine.

**IMPORTANT:** Do not start the engine without first adding motor oil. Severe engine damage will result if the engine is run without oil.

1. Refer to the Engine Owner's Manual for engine oil specifications and capacities.
2. With the tiller on level ground, move the Depth Regulator Lever (FF, Fig. 2-10) up or down until the engine is level.
3. Add motor oil as described in the Engine Owner's Manual.

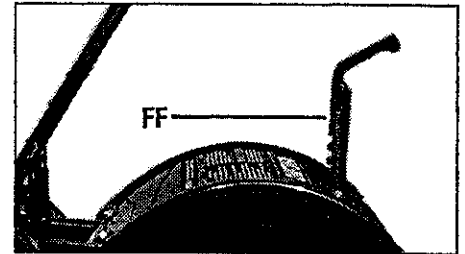

Fig. 2-10: Adjust Depth Regulator Lever.

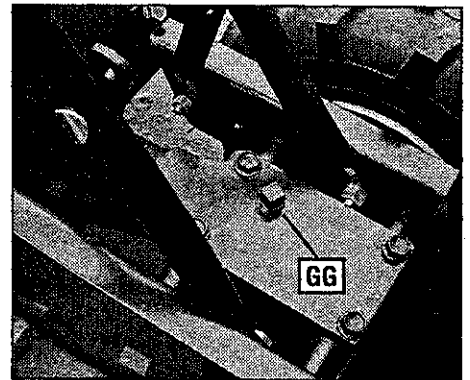

Fig. 2-11: Remove gear oil fill plug.

4. Move the Depth Regulator Lever all the way down until the highest notch is engaged. This places the tines in the "travel" position.

### STEP 8: Check Hardware for Tightness

Check all nuts and screws for tightness.

### STEP 9: Check Air Pressure in Tires (units with pneumatic tires)

If the tires are equipped with air valves, check the air pressure with a tire gauge. Deflate or inflate the tires equally to 15-to-20 PSI (pounds per square inch). Be sure that both tires are inflated equally or the unit will pull to one side.

**IMPORTANT:** This completes the assembly steps. Before operating your tiller, make sure you read the following Sections in this Manual, as well as the separate Engine Owner's Manual:

- Section 1: "Safety"
- Section 3: "Features and Controls"
- Section 4: "Operation"

# Section 3 Features and Controls

## **⚠ WARNING**

Before operating your machine, carefully read and understand all safety, controls and operating instructions in this Manual, the separate Engine Owner's Manual, and on the decals on the machine.

Failure to follow these instructions can result in serious personal injury.

## Introduction

This section describes the locations and functions of the controls on your tiller. Refer to the next section "Operation" for detailed operating instructions.

Practice using these controls, with the engine shut off, until you understand the operation of the controls and feel confident with each of them.

**IMPORTANT:** Refer to the separate engine manufacturer's Engine Owner's Manual for information about the controls on the engine.

## Wheel Drive Pins

### **⚠ WARNING**

Never allow either of the wheels to be in the FREEWHEEL position when the engine is running. Always put both wheels in the WHEEL DRIVE position before starting the engine.

Failure to comply could cause loss of tiller control, property damage, or personal injury.

Each wheel is equipped with a Wheel Drive Pin (A, Figures 3-2 and 3-3) that secures the wheel to the wheel shaft (B). The wheels can be positioned in either a WHEEL DRIVE or a FREEWHEEL mode.

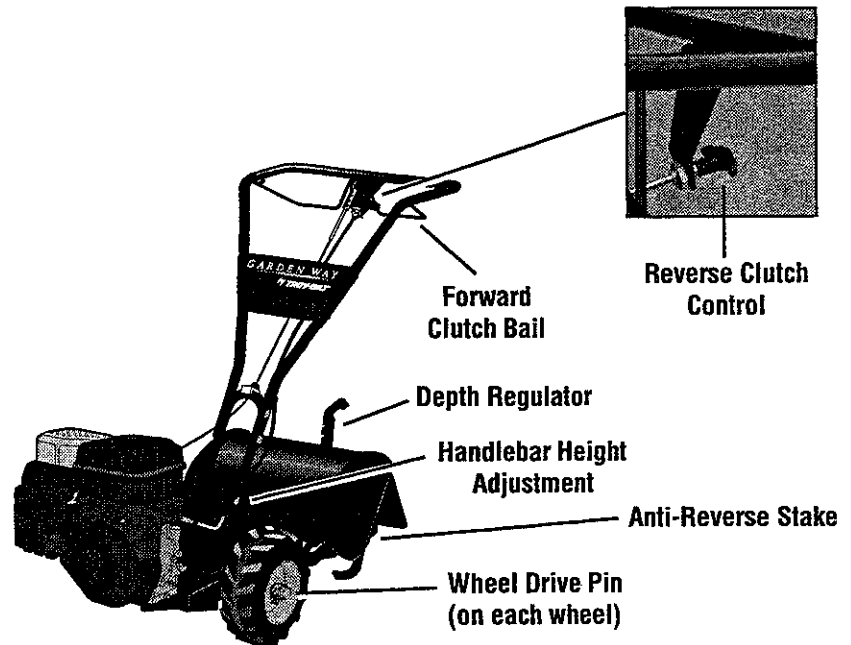

Figure 3-1: Features and controls.

Before starting the engine, put both wheels in the WHEEL DRIVE position by inserting the Wheel Drive Pins through the wheel hubs and the wheel shaft. This "locks" the wheels to the wheel shaft, causing the wheels to turn when either the Forward Clutch Bail or the Reverse Clutch Control is engaged.

Use the FREEWHEEL mode only when the engine is not running. In FREEWHEEL, the Wheel Drive Pins are placed only through the holes in the wheel shaft (not the wheel hubs), thus allowing the wheels to turn freely when the tiller is pushed or pulled by hand.

To Place the Wheels in WHEEL DRIVE or FREEWHEEL:

### **⚠ WARNING**

Do not place the tiller on its side when changing the wheel drive positions as doing so could result in gasoline leaking from the fuel tank.

Failure to follow this instruction could result in personal injury or property damage.

1. Stop the engine, disconnect the spark plug wire from the spark plug and allow the engine to cool.
2. Raise one wheel off the ground and place a sturdy support under the unit.
3. Remove the hairpin cotter (C, Figures 3-2 and 3-3) and the wheel drive pin (A).

## 4. FOR WHEEL DRIVE mode (Figure 3-2):

Slide the wheel outward on the wheel shaft (B, Figure 3-2) and insert the wheel drive pin (A) through the wheel hub (D) and the wheel shaft (B). The wheel is now locked to the wheel shaft. Install the hairpin cotter (C) on the wheel drive pin, pushing the hairpin cotter in as far as it will go. Repeat for the other wheel and remove the support from the unit.

## 5. FOR FREEWHEEL mode (Figure 3-3):

Slide the wheel inward and insert the wheel drive pin (A, Figure 3-3) only through the hole in the wheel shaft (B). Install the hairpin cotter (C) on the wheel drive pin, pushing the hairpin cotter in as far as it will go. Repeat for the other wheel and remove the support from the unit.

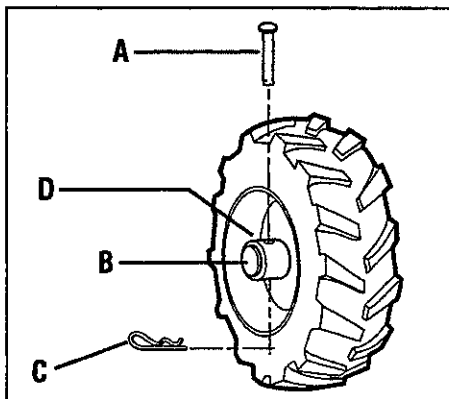

Figure 3-2: WHEEL DRIVE position.

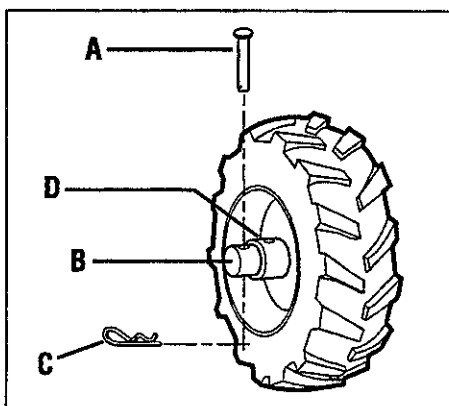

Figure 3-3: FREEWHEEL position.

## ⚠ WARNING

**Before starting the engine, be sure that both wheels are in the WHEEL DRIVE position. See "Wheel Drive Pins" for instructions.**

**Engaging the Forward Clutch Bail or the Reverse Clutch Control (if so equipped) when the wheels are not in the WHEEL DRIVE position could allow the tines to rapidly propel the tiller forward or backward.**

**Failure to comply could cause loss of tiller control, property damage, or personal injury.**

## Forward Clutch Bail

The Forward Clutch Bail (E, Figure 3-4) controls the engagement of forward drive to the wheels and power to the tines.

**NOTE:** The wheels will rotate in a forward direction; the tines will rotate counter-clockwise (backward toward the operator).

### To Operate the Forward Clutch Bail:

1. Put the wheels in the WHEEL DRIVE position (see the "WARNING" statement above).
2. Lift and hold the bail against the handlebar. The wheels and tines will rotate and the tiller will move in a forward direction.
3. Release the bail to disengage (stop) the wheels and tines. Forward tiller motion will stop (the engine will continue to run).

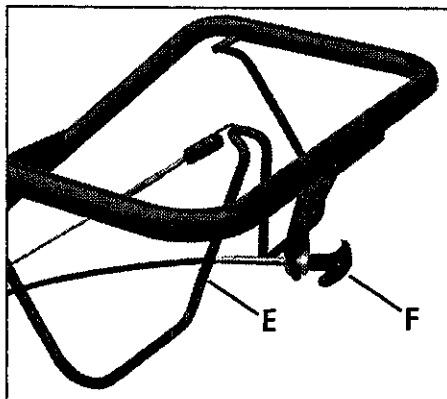

Figure 3-4: Forward Clutch Bail (E) and Reverse Clutch Control (F).

## Reverse Clutch Control

The Reverse Clutch Control (F, Figure 3-4) controls the engagement of reverse drive to the wheels and tines. **This powered reversing feature is used for maneuvering the tiller only – never engage the tines in the ground while going in the reverse direction.**

## ⚠ WARNING

• **Use extreme caution when reversing or pulling the machine towards you. Look behind to avoid obstacles.**

• **Never attempt to till in reverse.**

**Failure to follow this warning could result in personal injury or property damage.**

### To Operate the Reverse Clutch Control:

1. Operate only when the wheels are in the WHEEL DRIVE position (see the "WARNING" statement at the left).
2. Stop all tiller motion by releasing the Forward Clutch Bail.
3. Lift up the handlebar until the tines clear the ground, look behind you to avoid any obstacles, and then pull the Reverse Clutch Control knob toward you. The wheels will rotate in a reverse direction.
4. Release the Reverse Clutch Control knob to disengage (stop) the wheels and tines. All reverse motion will stop (the engine will continue to run).

## Section 3: Features and Controls

### Depth Regulator Lever

This lever (G, Figure 3-5) controls the tilling depth of the tines. Pull the lever straight back and slide it up or down to engage the notched height settings.

#### **⚠ WARNING**

Place the Depth Regulator Lever in the "travel" position before starting the engine. This position prevents the tines from touching the ground until you are ready to begin tilling.

Failure to follow this warning could result in personal injury or property damage.

The highest notch (lever all the way down) raises the tines approximately 1-1/2" off the ground. This "travel" setting allows the tiller to be moved without the tines digging into the ground. Also use this setting when starting the engine.

Move the lever upward to increase the tilling depth. The lowest notch allows a tilling depth of approximately 6", depending on soil conditions.

For best results, begin tilling at the deepest depth possible without causing the tiller to bog down. Increase the tilling depth from one pass over the soil to the next.

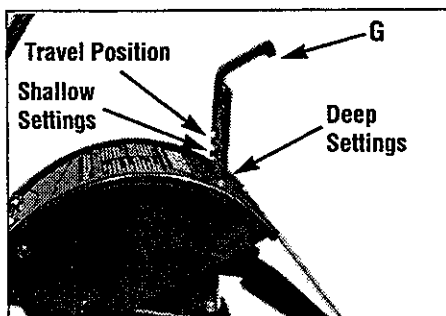

Figure 3-5: Depth Regulator Lever.

### Handlebar Height Adjustment

The handlebar height is adjustable to three different settings (see Figure 3-6). As a general rule, adjust the handlebars so they are at waist level when the tines are 3"-4" into the soil.

#### To Adjust the Handlebars:

1. Stop the engine, disconnect the spark plug wire from the spark plug and allow the engine to cool.
2. Remove the screws, lockwashers and nuts, reposition the handlebars, and reinstall the hardware.

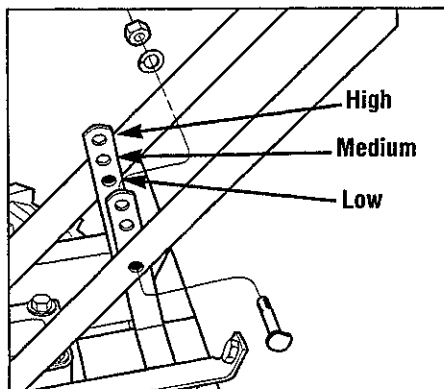

Figure 3-6: Handlebar height adjustment.

### Anti-Reverse Stake

The Anti-Reverse Stake (H, Figure 3-7) is located at the rear of the tines. Its purpose is to automatically help prevent the counter-rotating-tines from letting the tiller backup in the direction of the operator if the tiller wheels had been inadvertently left in the FREEWHEEL position. In this situation, the Anti-Reverse Stake will be forced down into the ground, lifting the tines upward out of the soil and helping prevent backward motion of the tiller.

The Anti-Reverse Stake requires no adjustment, but should be inspected before each tiller use to verify that it swivels freely. Remove any clogged materials (dirt, roots, rocks, etc.) that prevent the Anti-Reverse Stake from swinging freely.

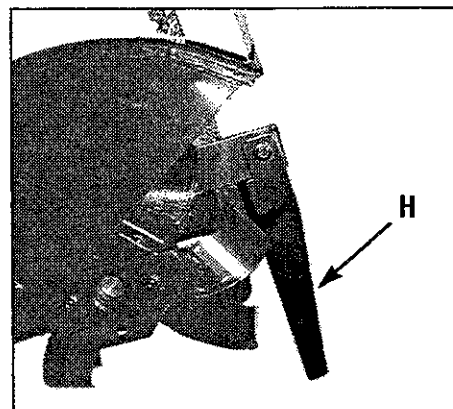

Figure 3-7: Anti-Reverse Stake.

### ENGINE CONTROLS

Refer to the engine manufacturer's Engine Owner's Manual (included in the tiller literature package) to identify the controls on your engine.

**IMPORTANT:** The control for stopping the engine is located on the engine.

# Section 4 Operation

## **⚠ WARNING**

Before operating your machine, carefully read and understand all safety (Section 1), controls (Section 3) and operating instructions (Section 4) in this Manual, in the separate Engine Owner's Manual, and on the decals on the machine.

Failure to follow these instructions can result in serious personal injury.

## **INTRODUCTION**

Read this Section of the manual thoroughly before you start the engine. Then, take the time to familiarize yourself with the basic operation of the tiller before using it in the garden. Find an open, level area and practice using the tiller controls without the tines engaging the soil (put tines in "travel" setting). Only after you've become completely familiar with the tiller should you begin using it in the garden.

## **BREAK-IN OPERATION**

Perform the following maintenance during the first hours of new operation (see "Maintenance" section in this manual and in the Engine Owner's Manual).

1. Change engine oil after first 2 hours of new engine operation.
2. Check for loose or missing hardware on unit. Tighten or replace as needed.
3. Check tension on forward drive belt after first 2 hours of operation.
4. Check transmission gear oil level after first 2 hours of operation.

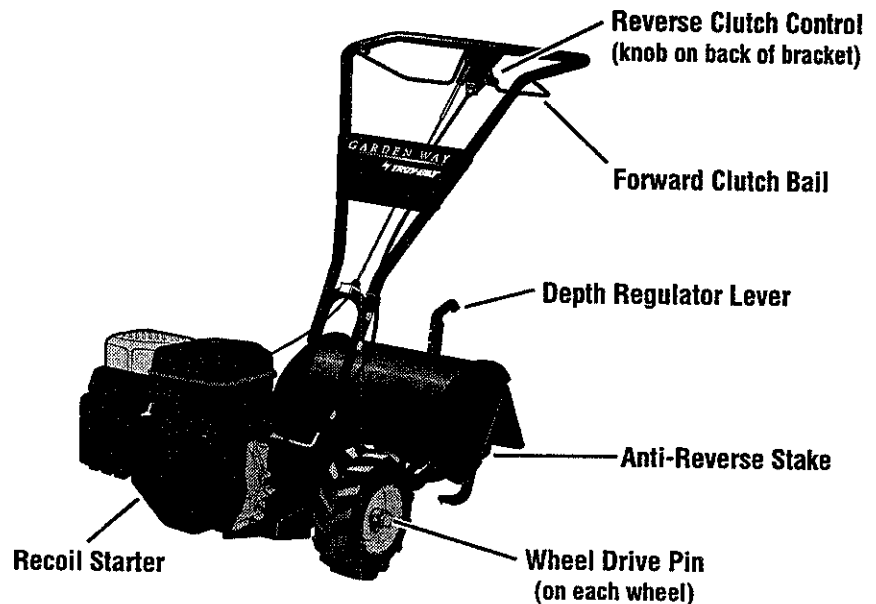

Figure 4-1

## **STARTING AND STOPPING THE ENGINE**

### **Pre-Start Checklist**

Make the following checks and perform the following services before starting the engine.

1. Read the "Safety" and "Controls" Sections in this Manual. Read the separate Engine Owner's Manual provided by the engine manufacturer.
2. Check that the wheels are in the WHEEL DRIVE position (wheel pins must be through the wheel hubs and the wheel shaft holes).
3. Check unit for loose or missing hardware. Service as required.
4. Check engine oil level. See Engine Owner's Manual.
5. Check that all safety guards and covers are in place.
6. Check air cleaner and engine cooling system. See Engine Owner's Manual.

7. Attach spark plug wire to spark plug.
8. Fill the fuel tank with gasoline according to the directions in the separate Engine Owner's Manual. Follow all instructions and safety rules carefully.

## **⚠ DANGER**

**GASOLINE IS HIGHLY FLAMMABLE AND ITS VAPORS ARE EXPLOSIVE.**

Follow gasoline safety rules in this Manual (see Section 1) and in the separate Engine Owner's Manual.

Failure to follow gasoline safety instructions can result in serious personal injury and property damage.

## Section 4: Operation

### Starting the Engine

The following steps describe how to start and stop the engine. **Do not attempt to engage tines or wheels until you have read all the operating instructions in this Section. Also review the safety rules in Section 1: "Safety" and the tiller and engine controls information in Section 3: "Features and Controls."**

#### **⚠ CAUTION**

To help prevent serious personal injury or damage to equipment:

- Before starting engine, put both wheels in the WHEEL DRIVE position. Never have the wheels in the FREEWHEEL position when the engine is running. When the wheels are in FREEWHEEL, they do not hold back the tiller and the tines could propel the tiller rapidly backward.
- Before starting engine, put Forward Clutch Bail (all Models) and Reverse Clutch Control in neutral (disengaged) positions by releasing levers.
- Never run engine indoors or in enclosed, poorly ventilated areas. Engine exhaust contains carbon monoxide, an odorless and deadly gas.
- Avoid engine muffler and nearby areas. Temperatures in these areas may exceed 150°F.

1. Complete the "Pre-Start Checklist" on the previous page.
2. Put the wheels in the WHEEL DRIVE position (see "Wheel Drive Pins" in Section 3).
3. Put the Depth Regulator Lever in the "travel" position (lever all the way down) so that the tines are clear of the ground.
4. Release all controls on the tiller.
5. If engine is equipped with a fuel valve, turn valve to open position as instructed in the separate Engine Owner's Manual.
6. Put ignition switch and/or throttle control lever on engine in "ON," "RUN,"

7. Choke or prime engine as instructed in the separate Engine Owner's Manual.

8. Place one hand on the fuel tank to stabilize the unit when you pull the starter handle. Use the recoil starter rope to start the engine as instructed in the separate Engine Owner's Manual. When engine starts, gradually move choke lever (on engines so equipped) to "NO CHOKE," "CHOKE OFF" or "RUN" position.

9. Use the "FAST" throttle speed setting when tilling.

#### **⚠ WARNING**



**Keep away from rotating tines. Rotating tines will cause injury.**

### Stopping the Engine and Tiller

1. To stop the wheels and tines, release the Forward Clutch Bail or the Reverse Clutch Control, whichever control is in use.
2. To stop the engine, put the ignition switch and/or the throttle control lever on the engine in the "OFF" or "STOP" position.

### OPERATING THE TILLER

The following pages provide guidelines to using your tiller effectively and safely in various gardening applications. Be sure to read "Tilling Tips & Techniques" in this Section before you actually put the tines into the soil.

This is a CRT (counter-rotating-tine) tiller. As the wheels pull forward, the tines rotate backward. This creates an "uppercut" tine action which digs deeply, uprooting soil and weeds. Don't overload the engine, but dig as deeply as possible on each pass. On later passes, the wheels may tend to spin in the soft dirt. If necessary, help them along by lifting up slightly on the handlebar (palm facing up).

1. Follow the "Pre-Start Checklist" on the previous page. Be sure that the wheels are in the WHEEL DRIVE position.

2. Put the Depth Regulator Lever in the "travel" position (lever all the way down) so that the tines are clear of the ground. Use this position when practicing with your tiller or when moving to or from the garden. When you are ready to begin tilling, you must move the Depth Regulator Lever to the desired depth setting (see "Tilling Tips & Techniques"). Check that the Anti-Reverse Stake swivels freely back and forth. Remove any clogged material on or around the stake.

3. Start the engine and allow it to warm up. When warm, put throttle control in fast speed setting.



**Figure 4-2: Use one hand to guide tiller when moving forward.**

4. For forward motion of wheels and power to the tines:

- (a) Pull the Forward Clutch Bail up and hold it against the handlebar. Release the bail to stop forward motion of the wheels and power to the tines.
- (b) As the tiller moves forward, relax and let the wheels pull the unit along while the tines dig. Walk behind and a little to one side of the tiller. Use a light but secure grip with one hand on the handlebars, keeping your arm loose. See Figure 4-2. Let the tiller move at its own pace and do not push down on the handlebars to try to dig deeper—this takes weight off the wheels, cuts traction, and causes the tines to try and propel the tiller.

## ⚠ WARNING

Do not push down on the handlebars to try to make the tiller till more deeply. This prevents the wheels from holding the tiller back and can allow the tines to rapidly propel the tiller backward toward the operator, which could result in loss of control, property damage, or personal injury.

5. For reverse motion of the wheels and tines:

- Look behind and exercise caution when operating in reverse. Do not till while in reverse.
- Stop all forward motion before reversing. Lift the handlebars with one hand until the tines are off the ground and then pull the Reverse Clutch Control knob out to engage reverse motion (see Figure 4-3). To stop reverse motion, let go of the Reverse Clutch Control knob.

6. To Turn the Tiller Around:

- Practice turning the tiller in a level, open area. Be very careful to keep your feet and legs away from the tines.
- To make a turn, lift the handlebars until the engine and tines are balanced over the wheels (Figure 4-4). The tines must be out of the ground while turning the tiller.
- With the tiller balanced, push sideways on the handlebar to move the tiller in the direction of the turn (Figure 4-5). After completing the turn, slowly lower the tines into the soil to resume tilling.

### Stopping the Tiller and Engine

- To stop the wheels and tines, release the Forward Clutch Bail or the Reverse Clutch Control, whichever control is engaged.
- To stop the engine, move the ignition switch and/or the throttle control lever on the engine to the "OFF" or "STOP" position.



Figure 4-3: Raise tines off ground and look behind when moving in reverse.

### Turning the Tiller Around



Figure 4-4: To begin turn, lift handlebars until engine and tines are balanced over wheels. Be sure tines are out of ground.



Figure 4-5: With tiller balanced over wheels (and tines out of the ground), push handlebars sideways to turn tiller.

## ⚠ WARNING

Before tilling, contact your telephone or utilities company and inquire if underground equipment or lines are used in your area. Their representative will be glad to answer your questions and tell you if any of their equipment or lines are buried underground on your property.

### LOADING AND UNLOADING THE TILLER

## ⚠ WARNING

Loading and unloading the tiller into or from a vehicle is potentially hazardous. We don't recommend doing so unless absolutely necessary, as this could result in personal injury or property damage.

However, if you must load or unload the tiller, follow the guidelines given next.

- Before loading or unloading, stop the engine, wait for all parts to stop moving, disconnect the spark plug wire and let the engine and muffler cool.
- The tiller is too heavy and bulky to lift safely by one person. Two or more people should share the load.
- Use sturdy ramps and manually (engine shut off) roll the tiller into and out of the vehicle. Two or more people are needed to do this.
- Ramps must be strong enough to support the combined weight of the tiller and any handlers. The ramps should provide good traction to prevent slipping; they should have side rails to guide the tiller along the ramps; and they should have a locking device to secure them to the vehicle.
- The handlers should wear sturdy footwear that will help to prevent slipping.

(Continued on next page)

## Section 4: Operation

- Position the loading vehicle so that the ramp angle is as flat as possible (the less incline to the ramp, the better). Turn the vehicle's engine off and apply its parking brake.
- When going up ramps, stand in the normal operating position and push the tiller ahead of you. Have a person at each side to turn the wheels.
- When going down ramps, walk backward with the tiller following you. Keep alert for any obstacles behind you. Position a person at each wheel to control the speed of the tiller. Never go down ramps tiller-first, as the tiller could tip forward.
- Use wooden blocks to place on the downhill side of the wheels if you need to stop the tiller from rolling down the ramp. Also, use the blocks to temporarily keep the tiller in place on the ramps (if necessary), and to chock the wheels in place after the tiller is in the vehicle.
- When the tiller is in the vehicle, prevent it from rolling by chocking the wheels with blocks and securely tie the tiller down.

### Tilling Tips & Techniques

#### LET THE TILLER DO THE WORK

- While tilling, relax and let the wheels pull the tiller along while the tines do the digging. Walk on the side that is not yet finished (to avoid making footprints in the freshly tilled soil) and lightly, but securely grip the handlebar with just one hand. See Figure 4-2.
- Avoid pushing down on the handlebars in an attempt to force the tiller to dig deeper. Doing so takes the weight off the powered wheels, causing them to lose traction. Without the wheels helping to hold the tiller back, the tines will attempt to propel the tiller backward toward the operator— often causing the tiller to skip rapidly across the ground.

#### TILLING DEPTHS

- When preparing the soil, till a fresh path on each pass rather than overlapping passes. This gives the wheels maximum traction on undisturbed soil (later passes can be overlapped). See Figure 4-6. Dig as deeply as possible on each pass, without overloading the engine. (Watering the garden area a few days prior to tilling will make tilling easier, as will letting the newly worked soil set for a day or two before making a final, deep tilling pass.)
- When cultivating (breaking up the surface soil around plants to help destroy weeds), use very shallow depth settings to prevent injury to plants whose roots often grow close to the surface. *If needed, lift up on the handlebars slightly to prevent the tines from digging too deeply.* Cultivating on a regular basis not only eliminates weeds, it also loosens and aerates the soil for better moisture absorption and faster plant growth.

#### AVOID TILLING WET, SOGGY SOIL

Tilling wet soil may result in large, hard clumps of soil that can interfere with planting. If time permits, wait a day or two after heavy rains to allow the soil to dry. Test the soil by squeezing it into a ball. If it compresses too easily, it is too wet to till.

#### AVOID MAKING FOOTPRINTS

Whenever possible, walk on the untilled side of the unit to avoid making footprints in the freshly tilled soil. Footprints cause soil compaction that can hamper root penetration and contribute to soil erosion. They can also “plant” unwanted weed seeds back into the freshly tilled ground.

#### CHOOSING CORRECT WHEEL AND TINE SPEEDS

With experience, you will find the “just right” tilling depth and tilling speed combination that is best for your garden.

Set the engine throttle lever at a high enough speed to give the engine adequate power, and yet allow it to operate without laboring. Fastest engine speeds may be desirable when making final passes through the seedbed or when cultivating. Selection of the correct engine speed, in relation to the tilling depth, will ensure a sufficient power level to do the job without causing the engine to labor.

#### SUGGESTED TILLING PATTERNS

- When preparing a seedbed, go over the same path twice in the first row, then make individual passes right next to each other (see Figure 4-6). When finished in one direction, make second passes at a right angle as shown in Figure 4-7. In very hard ground, it may take three or four overlapping passes to thoroughly pulverize the soil. (See Figure 4-8.)

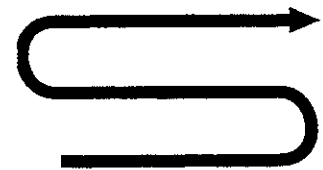

Figure 4-6



## Tilling Tips & Techniques

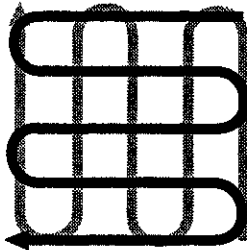

Figure 4-7

- If the garden size will not permit lengthwise and then crosswise tilling, then overlap the first passes by one-half a tiller width, followed by successive passes at one-quarter width (see Figure 4-8).

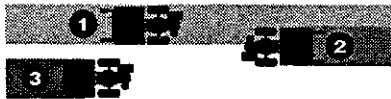

Figure 4-8

- With planning, you can allow enough room between rows to cultivate (see Figure 4-9). Leave room for the hood width, plus enough extra room for future plant growth.

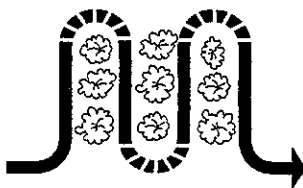

Figure 4-9

### CLEARING THE TINES

Dry grass, stringy stalks or tough vines may become tangled in the tines. Follow these procedures to help avoid tangling and to clean the tines, if necessary.

- To reduce tangling, set the depth regulator to its maximum depth.
- While tilling, try swaying the handlebars from side to side (about 6" to 12"). This "fishtailing" action often clears the tines of debris.
- If tangling occurs, lift the tines out of the soil and run the tiller in reverse for a few feet. This may unwind a good deal of debris.
- It may be necessary to remove the debris by hand (a pocket knife will help you to cut away the material).

### ⚠ WARNING

Before clearing the tines by hand, stop the engine, allow all moving parts to stop and disconnect the spark plug wire.

**Failure to follow this warning could result in personal injury.**

### TILLING ON SLOPES

If you must garden on a moderate slope, please follow two very important guidelines:

1. Till only on moderate slopes, never on steep ground where footing is difficult (review safety rules in the "Safety" Section of this Manual).
2. We recommend tilling up and down slopes, rather than terracing. Tilling vertically on a slope allows maximum planting area and also leaves room for cultivating.

**IMPORTANT:** When tilling on slopes, be sure the correct oil level is maintained in the engine (check every one-half hour of operation). The incline of the slope will cause the oil to slant away from its normal level and this can starve engine parts of required lubrication. Keep the engine oil level at the full point at all times!

#### A. Tilling up and down slopes:

- To keep soil erosion to a minimum, be sure to add enough organic matter to the soil so that it has good moisture-holding texture and try to avoid leaving footprints or wheel marks.
- When tilling vertically, try to make the first pass uphill as the tiller digs more deeply going uphill than it does downhill. In soft soil or weeds, you may have to lift handlebars slightly while going uphill.

#### B. Tilling across slopes without using terraces:

If the previously described tilling methods aren't practical for you, then you can till laterally across a slope. However, we don't really recommend this method as it can create unsure footing and invites soil erosion.

# Section 5 Maintenance

## ⚠ WARNING

Before inspecting, cleaning or servicing the machine, shut off engine, wait for all moving parts to come to a complete stop, disconnect spark plug wire and move wire away from spark plug. Remove ignition key on electric start models.

Failure to follow these instructions can result in serious personal injury or property damage.

REQUIRED MAINTENANCE SCHEDULE				
PROCEDURE	Before Each Use	Every 10 Hours	Every 30 Hours	As Noted
Check engine oil level	•			And every 5 operating hours
Clean engine	•			▲
Check drive belt tension		•		†
Check nuts and bolts		•		†
Change engine oil		•		*
Lubricate tiller		•		
Service engine air cleaner system				▲
Check gear oil level in transmission			•	†
Check tines for wear			•	
Check air pressure in tires (if equipped with pneumatic tires)				•
Service spark plug				▲
Check Anti-Reverse Stake	•			
* Change more frequently in dusty or dirty conditions. Change after first 2 hours of break-in operation. † Check after first 2 hours of break-in operation. ▲ See Engine Owner's Manual for service intervals and instructions.				

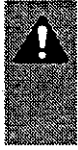

**WARNING** Before inspecting, cleaning or servicing the unit, shut off engine, wait for all parts to come to a complete stop, disconnect spark plug wire and move wire away from spark plug. Failure to follow these instructions can result in serious personal injury or property damage.



## TILLER LUBRICATION

Proper lubrication of the tiller is an essential part of maintenance. After every 10 operating hours, oil or grease the lubrication points shown in Figures 5-1 and 5-1A and described below.

Use general purpose lubricating oil (#30 weight motor oil is suitable) and general purpose grease (grease that contains a metal lubricant is preferred, if available).

- Remove wheels, clean wheel shaft (A, Fig. 5-1) and apply light coating of grease to shaft.
- Grease back, front and sides of Depth Regulator Lever (B, Fig. 5-1).
- Remove tines, clean tine shafts (C, Fig. 5-1) and apply light coating of grease to shaft.
- Oil the handlebar height adjustment screws and the handlebar attaching screws (D, Fig. 5-1).
- Lightly oil the shifting mechanism pivot points (E, Fig. 5-1A). Do not get oil on the belt or belt groove of the pulley.

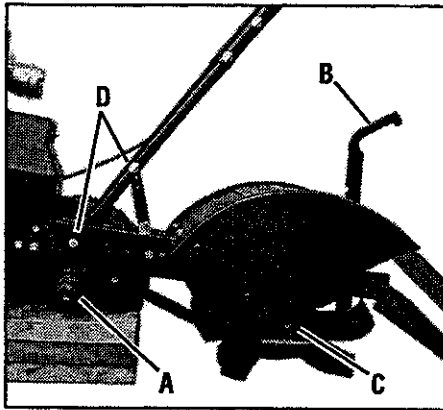

Figure 5-1

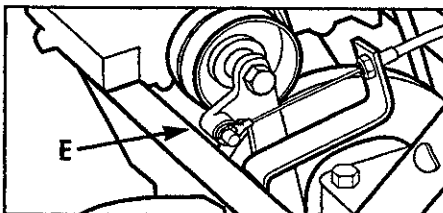

Figure 5-1A

## CHECK FOR GEAR OIL LEAKS

Before each use, check the transmission housing (and the ground beneath the unit) for any sign of a gear oil leak.

A little seepage around a cover or an oil seal is usually harmless. However, if oil drips overnight, then immediate attention is needed as ignoring a leak can result in severe transmission damage.

If a cover is leaking, try tightening any loose screws. If the screws are tight, a new gasket or oil seal may be needed. If the leak is from around a shaft and oil seal, the oil seal probably needs to be replaced. See your authorized dealer or contact the factory for service or advice. **IMPORTANT:** Never operate the tiller if the transmission is low on gear oil. Check the oil level after every 30 hours of operation and whenever there is any oil leakage.

## CHECK HARDWARE

After every 10 operating hours, thoroughly inspect the unit for any loose or missing screws, bolts and other fasteners. Tighten or replace the fasteners as needed. Be sure to check the screws underneath the tine hood that secure the transmission cover and the Depth Regulator Lever to the transmission.

## CHECK TIRE PRESSURE (on units equipped with pneumatic tires)

Check the air pressure in both tires. Deflate or inflate both tires evenly to 15-20 PSI (pounds per square inch). Be sure that both tires have the same air pressure or the unit will tend to pull to one side.

## TRANSMISSION GEAR OIL SERVICE

Check the transmission gear oil level after every 30 hours of operation or whenever you notice an oil leak. **IMPORTANT:** Operating the tiller when the transmission is low on oil can result in severe damage.

### A. To Check the Transmission Gear Oil Level:

1. The transmission must be cool (warm operating temperatures will provide an incorrect oil level reading).
  2. The transmission must be level.
  3. Remove the oil fill plug (A, Fig. 5-2) and look into the oil fill hole. The main drive shaft is visible inside the hole.
  4. The oil level is correct if it is approximately halfway up the side of the drive shaft.
  5. If the oil level is low, add gear oil as described next. If the oil level is okay, securely replace the oil fill plug.
  6. If only a few ounces of gear oil is needed, use API rated GL-4 or GL-5 gear oil having a viscosity of SAE 140, SAE 85W-140 or SAE 80W-90. If refilling an empty transmission, use only GL-4 transmission gear oil having a viscosity of SAE 85W-140 or SAE 140.
- IMPORTANT:** Do not use automatic transmission fluid or motor oil in the transmission.
7. Slowly pour gear oil into the oil fill hole until it reaches the halfway point on the drive shaft. Check frequently while pouring to avoid overfilling.
  8. Securely replace the oil fill plug.

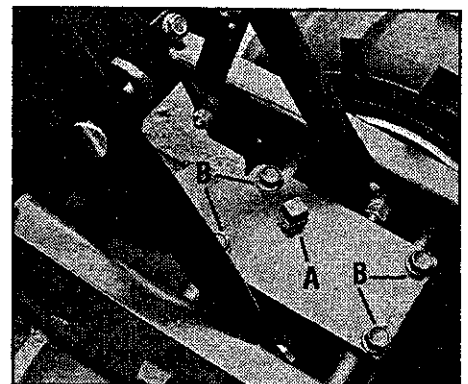
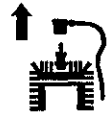

Figure 5-2: Remove oil fill plug (A) to check gear oil level and to add gear oil. Remove four cover screws (B) to drain gear oil.

## Section 5: Maintenance



**WARNING** Before inspecting, cleaning or servicing the unit, shut off engine, wait for all parts to come to a complete stop, disconnect spark plug wire and move wire away from spark plug. Failure to follow these instructions can result in serious personal injury or property damage.



### B. To Drain the Transmission Gear Oil:

The transmission gear oil does not need to be changed unless it has been contaminated with dirt, sand or metal particles.

#### **⚠ DANGER**

Gasoline is highly flammable and its vapors are explosive. Follow these safety practices to prevent personal injury or property damage from fire or explosion.

- Allow the engine and muffler to cool for at least two minutes before draining the tiller's gasoline tank.
- Do not allow open flames, sparks, matches or smoking in the area.
- Wipe away spills and push tiller away from spilled fuel.
- Use only an approved fuel container and store it safely out of the reach of children.
- Do not store gasoline in an area where its vapors could reach an open flame or spark, or where ignition sources are present (such as hot water and space heaters, furnaces, clothes dryers, stoves, electric motors, etc.).

1. Drain the gasoline from the fuel tank or run the engine until the fuel tank is empty. See "DANGER" statement above.
2. Drain the motor oil from the engine.
3. Remove four screws (B, Figure 5-2) and remove transmission cover and gasket.
4. Remove the left-side wheel.
5. Tilt the left-side wheel shaft into a drain pan and drain the gear oil through the top of the transmission.
6. Reinstall the wheel, install a new cover gasket (do not reuse old gasket) and reinstall the transmission cover.
7. Refill transmission using GL-4 gear oil (SAE 85W-140 or SAE 140).
8. Refill engine with motor oil and refill fuel tank with gasoline.

### TINES

The tines will wear with use and should be inspected at the beginning of each tilling season and after every 30 operating hours. The tines can be replaced individually or as a complete set. See the Parts List in this Manual for tine identification and ordering information.

#### **⚠ WARNING**

This is a CRT (counter-rotating-tine) tiller and its tines must be mounted in the direction shown in Figure 5-3. If mounted with curves in the opposite direction, tiller will dig poorly and be more likely to run backward.

Failure to comply could result in personal injury or property damage.

NOTE: Remove the tine hood before removing a tine holder or individual tines. Remove the two sets of screws at the front and the rear of the hood and lift off the hood. Replace the hood securely after changing a tine or tine holders.

#### A. Tine Inspection

With use, the tines will become shorter, narrower and pointed. Badly worn tines will result in a loss of tilling depth and will leave untilled gaps in the freshly turned soil.

#### B. Removing and Installing Tine Assemblies

1. A tine assembly consists of three tines mounted on a tine holder. To remove the assembly, remove the nut (A, Figure 5-3) and screw (B) that secure the tine holder to the tine shaft. If necessary, use a rubber mallet to tap the tine assembly off the tine shaft.
2. Inspect the tine shaft for rust or rough spots and remove using a fine grade sandpaper. Apply a light coating of grease to the tine shaft.

3. Installing the tine assembly is simply the reverse of its removal. *Be sure all the tine cutting edges face so they will enter the soil first when the tiller is moving forward—this means the cutting edge on the top of each tine faces toward the operator position.* Tighten hardware.

#### C. Removing and Installing Single Tines

1. To remove a single tine, remove the two screws (C, Figure 5-3) and nuts (D) that secure the tine to its tine holder. If needed, use penetrating oil on the nuts.
2. When installing individual tines, do so in the reverse order from which they were removed. The two sets of *inboard* tines are installed so one set faces toward the transmission and the other faces away from it. The single *outboard* tine set faces toward the transmission housing. *Also be sure the cutting edge at the top of each tine faces toward the operator position.* (See Figure 5-3.)

### CHECKING AND ADJUSTING FORWARD DRIVE BELT TENSION

Maintaining correct tension on the forward drive belt is important to good tilling performance and long belt life.

A loose belt will slip on the engine and transmission pulleys and cause the tines and wheels to slow down – or stop completely – even though the engine is running at full speed. A belt that is too tight can result in unintentional tine movement when the clutch bail is in the Neutral (released) position.

Also check the belt for cracks, cuts or frayed edges and replace it as soon as possible.

- Check belt tension after the first two hours of break-in operation (new belt).
- Check belt tension after every 10 operating hours.



**WARNING** Before inspecting, cleaning or servicing the unit, shut off engine, wait for all parts to come to a complete stop, disconnect spark plug wire and move wire away from spark plug. Failure to follow these instructions can result in serious personal injury or property damage.

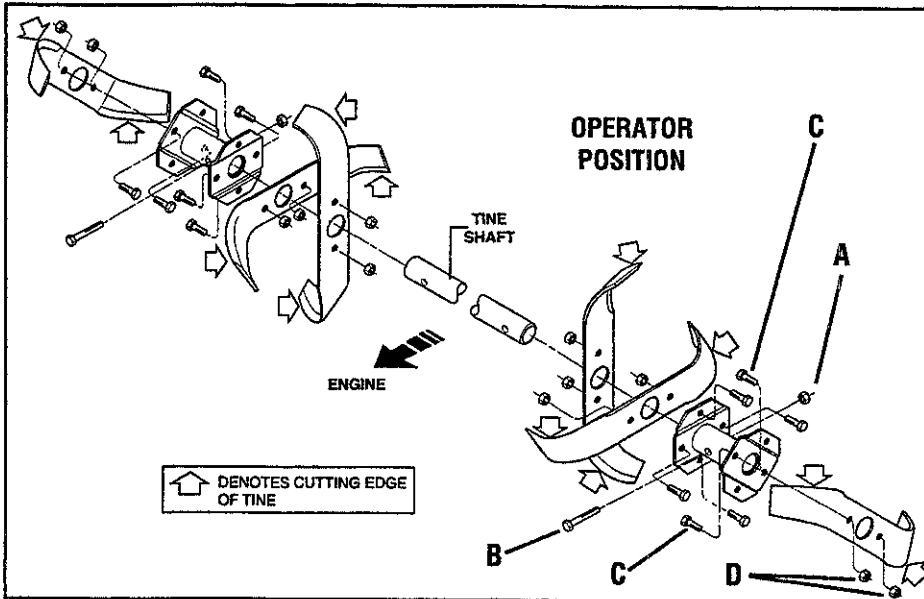
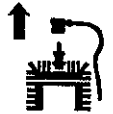

Figure 5-3: Tines, tine holders and installation hardware.

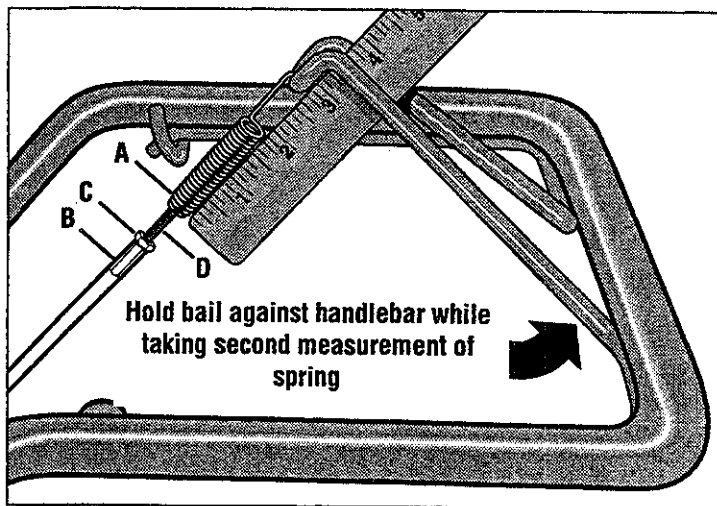

Figure 5-4: Checking forward belt tension.

### To Check Forward Belt Tension:

1. Stop the engine, wait for all parts to stop moving and disconnect the spark plug wire.
2. With the forward clutch bail in an open (released) position, measure and carefully note the overall length of the cable spring (A, Figure 5-4) by measuring from the outermost coil to the outermost coil.

3. Lift and hold the forward clutch bail against the handlebar (see Figure 5-4) and re-measure the overall length of the coils while the spring is under tension. The belt tension is correct if this second measurement is between 1/16" -to- 3/16" longer than the first measurement.
4. If the spring is too short (less than 1/16" greater than the first measurement), the tension is too loose. If the spring is

too long (more than 3/16" greater than the first measurement), the tension is too tight.

5. To adjust the length of the spring:
  - a. Release the Forward Clutch Bail.
  - b. Unthread the hex nut (C, Figure 5-4) about halfway up the adjustment screw (D).
  - c. Unhook the top of the spring from the forward clutch bail.
  - d. Use pliers to prevent the adjuster (B) from turning and turn the slotted screw clockwise (viewed from operator's position) to increase tension on the spring. Turn the screw counter-clockwise to decrease tension on the spring. Once adjusted, re-hook the top of the spring to the forward clutch bail. (Continue to Step 5e.)
  - e. Repeat Steps 2 and 3 to remeasure the length of the spring coils. When the second measurement (with bail closed against handlebar) is between 1/16" -to- 3/16" longer than the first measurement, retighten the hex nut (C) against the top of the adjuster (B).

### Replacement Belt Information

If the drive belt needs to be replaced, see your local authorized dealer or refer to the Parts List for ordering information. Use only a factory-authorized belt as an "over the counter" belt may not perform satisfactorily. The procedure requires average mechanical ability and commonly available tools.

### FORWARD CLUTCH BAIL ADJUSTMENT

If the Forward Clutch Bail does not function properly, first check that the forward drive belt is adjusted properly (see "Checking and Adjusting Forward Drive Belt Tension"). If this fails to correct the problem, contact the factory technical service department or your authorized dealer for service advice.

## Section 5: Maintenance



**WARNING** Before inspecting, cleaning or servicing the unit, shut off engine, wait for all parts to come to a complete stop, disconnect spark plug wire and move wire away from spark plug. Failure to follow these instructions can result in serious personal injury or property damage.



### CHECKING AND ADJUSTING REVERSE DRIVE BELT TENSION

Maintaining correct tension on the reverse drive belt is important to good performance and long belt life. A loose belt will slip on the engine and transmission pulleys and cause the tines and wheels to slow down – or stop completely – even though the engine is running at full speed. A loose belt can also result in premature belt wear.

If there is no reverse action when the Reverse Clutch Control knob is pulled out, then the belt tension is too loose.

When checking belt tension, also check the belt for cracks, cuts or frayed edges and replace it as soon as possible.

- Check belt tension after the first two hours of break-in operation (new belt).
- Check belt tension after every 10 operating hours.

#### To Check Reverse Belt Tension:

1. Be sure that the engine is stopped and the spark plug wire is disconnected and moved away from the spark plug.
2. Remove the screw in the plastic belt cover and slide the cover (which is attached to the forward clutch cable) out of the way.
3. Have an assistant pull the Reverse Clutch Control knob all the way out and hold it in that position. Measure the length of the cable wire between the end of the threaded cable adjuster (A, Figure 5-5) and the end of the Z-fitting (B) to which the cable wire is attached.
4. The belt tension is ideal if the cable wire length measures between 1/8" to 1/4". If the length is less than 1/8" (and if there is no reverse action when the tiller is running), then make the following adjustments. NOTE: If the length is more than 1/4", no adjustment is needed, as long as the reverse action functions properly.

5. Release the Reverse Clutch Control knob. Unthread the inner jam nut (C, Figure 5-6) one to two turns and pull the threaded cable adjuster (A, Figure 5-6) to the left until the inner jam nut rests against the bracket.

6. Prevent the inner jam nut (C) from turning and tighten the outer jam nut (D) against the bracket. Prevent the outer jam nut (D) from turning and tighten the inner jam nut (C) against the bracket.

7. Measure the gap by repeating Step 3. Readjust as needed by repeating Steps 5 and 6.

8. Reinstall the belt cover.

#### Reverse Belt Replacement Information

If the drive belt needs to be replaced, see your local authorized dealer or refer to your Parts Catalog for ordering information. Use only a factory-authorized belt as an "over the counter" belt may not perform satisfactorily. The procedure requires average mechanical ability and commonly available tools.

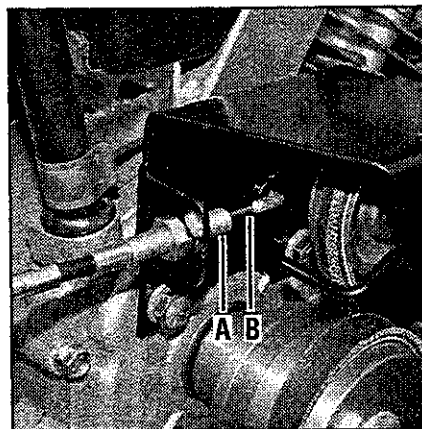

*Figure 5-5: Measure cable wire length to check for correct reverse belt tension.*

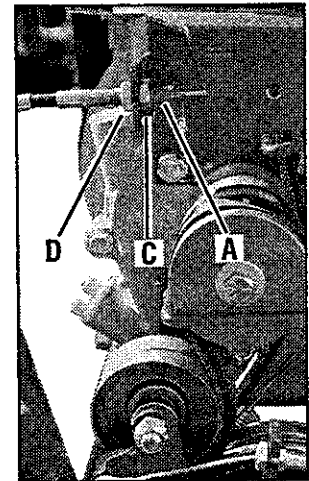

*Figure 5-6: Move threaded adjuster (A) to left to increase belt tension.*

### ENGINE CLEANING

Keep the engine clean to assure smooth operation and to prevent damage from overheating. Refer to the separate Engine Owner's Manual for specific repair and cleaning instructions. All inspections and services must be done with the engine shut off and cool to the touch.

### AIR CLEANER SERVICE

The engine air cleaner filters dirt and dust out of the air before it enters the carburetor. Operating the engine with a dirty, clogged air filter can cause poor performance and damage to the engine. Never operate the engine without the air cleaner installed. Inspect and service the air cleaner more often if operating in very dusty or dirty conditions.

Service the air cleaner as instructed in the separate Engine Owner's Manual.



**WARNING** Before inspecting, cleaning or servicing the unit, shut off engine, wait for all parts to come to a complete stop, disconnect spark plug wire and move wire away from spark plug. Failure to follow these instructions can result in serious personal injury or property damage.

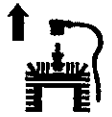

### ENGINE OIL SERVICE

Check the engine oil level before starting the engine each day and check it after each 5 hours of continuous operation. Running the engine when it is low on oil will quickly ruin the engine.

It is recommended that you change the motor oil after every 10 hours of operation and even sooner when operating in extremely dirty or dusty conditions. Refer to the separate Engine Owner's Manual for detailed service instructions.

#### A. To Check the Engine Oil Level:

1. Move the tiller to a level area and shut off the engine.
2. Level the engine.
3. Clean the area around the oil dipstick or oil fill tube to prevent dirt from falling into the crankcase.
4. On engines with an oil fill tube, remove the filler cap, add oil (if required) until it reaches the top of the tube and reinstall the filler cap.
5. On engines with a dipstick, remove it, wipe it clean, and reinstall it finger-tight. Remove the dipstick and check the reading. Add oil (if required) to bring the level to the FULL mark. Do not overfill.

#### B. To Change the Engine Oil:

Change the engine oil as instructed in the separate Engine Owner's Manual.

### SPARK PLUG SERVICE

Inspect and clean or replace the spark plug after every 100 operating hours or annually. Clean the plug and set the gap as described in the separate Engine Owner's Manual.

In some areas, local law requires using resistor spark plugs to suppress ignition signals. If the engine was originally equipped with a resistor spark plug, use the same type for replacement.

### SPARK ARRESTER SCREEN SERVICE

If the engine muffler is equipped with a spark arrester screen, remove and clean it according to the time intervals and instructions in the separate Engine Owner's Manual.

### THROTTLE LEVER ADJUSTMENT

If the engine does not respond to various throttle lever settings, refer to the separate Engine Owner's Manual for service information or contact your local authorized engine service dealer.

### CARBURETOR/GOVERNOR CONTROL ADJUSTMENTS

The carburetor was adjusted at the factory for best operating speed. Refer to the separate Engine Owner's Manual for any adjustment information or see your authorized engine service dealer.

The governor controls the maximum safe operating speed and protects the engine and all moving parts from damage caused by overspeeding. Do not tamper with the engine governor settings.

#### WARNING

**Operators shall not tamper with the engine governor settings on the machine; the governor controls the maximum safe operating speed to protect the engine and all moving parts from damage caused by overspeed. Authorized service shall be sought if a problem exists.**

### OFF SEASON STORAGE

When the tiller won't be used for extended periods, prepare it for storage as follows:

1. Clean the tiller and engine.
2. Do routine tiller lubrication and check for loose parts and hardware.
3. Protect the engine and perform recommended engine maintenance by following the engine storage instructions found in the separate Engine Owner's Manual. NOTE: Be sure to protect the fuel lines, carburetor and fuel tank from gum deposits by removing fuel or by treating fuel with a fuel stabilizer (follow engine manufacturer's recommendations).
4. Store unit in a clean, dry area.
5. Never store the tiller with fuel in the fuel tank in an enclosed area where gas fumes could reach an open flame or spark, or where ignition sources are present (space heaters, hot water heaters, furnaces, etc.).

## Section 5: Maintenance

### TROUBLESHOOTING

Before performing any corrections, refer to the appropriate information in this Manual, or in the Engine Owner's Manual, for the correct safety precautions and operating or maintenance procedures. Contact your local authorized Engine Service Dealer for engine service. Contact your local authorized equipment dealer or the factory for all other service problems.

PROBLEM	POSSIBLE CAUSE	CORRECTION
<b>Engine does not start.</b>	<ol style="list-style-type: none"> <li>1. Spark plug wire disconnected.</li> <li>2. Engine Throttle Control Lever incorrectly set.</li> <li>3. Fuel tank empty.</li> <li>4. Choke control (if so equipped) in incorrect position.</li> <li>5. Stale gasoline.</li> <li>6. Dirty air filter(s).</li> <li>7. Defective or incorrectly gapped spark plug.</li> <li>8. Carburetor out of adjustment.</li> <li>9. Misadjusted throttle control cable.</li> <li>10. Dirt or water in fuel tank.</li> </ol>	<ol style="list-style-type: none"> <li>1. Reconnect wire.</li> <li>2. Put lever in START position.</li> <li>3. Add fuel.</li> <li>4. See Engine Owner's Manual.</li> <li>5. Drain fuel and add fresh fuel.</li> <li>6. Clean or replace filter(s).</li> <li>7. Inspect spark plug.</li> <li>8. See Engine Service Dealer.</li> <li>9. See Engine Service Dealer</li> <li>10. See Engine Service Dealer.</li> </ol>
<b>Engine runs poorly.</b>	<ol style="list-style-type: none"> <li>1. Defective or incorrectly gapped spark plug.</li> <li>2. Dirty air filter(s).</li> <li>3. Carburetor out of adjustment.</li> <li>4. Stale gasoline.</li> <li>5. Dirt or water in fuel tank.</li> <li>6. Engine cooling system clogged.</li> </ol>	<ol style="list-style-type: none"> <li>1. Inspect spark plug (see Engine Owner's Manual).</li> <li>2. Clean or replace (see Engine Owner's Manual).</li> <li>3. See Engine Service Dealer.</li> <li>4. Replace with fresh gasoline.</li> <li>5. See Engine Service Dealer.</li> <li>6. Clean air cooling system (see Engine Owner's Manual).</li> </ol>
<b>Engine overheats.</b>	<ol style="list-style-type: none"> <li>1. Engine cooling system clogged.</li> <li>2. Carburetor out of adjustment.</li> <li>3. Oil level is low.</li> </ol>	<ol style="list-style-type: none"> <li>1. Clean air cooling area (see Engine Owner's Manual).</li> <li>2. See Engine Service Dealer.</li> <li>3. Check oil level (see Engine Owner's Manual).</li> </ol>
<b>Engine does not shut off.</b>	<ol style="list-style-type: none"> <li>1. Misadjusted throttle control or ignition switch.</li> </ol>	<ol style="list-style-type: none"> <li>1. See Engine Owner's Manual or Engine Service Dealer.</li> </ol>
<b>Wheels and Tines will not turn.</b>	<ol style="list-style-type: none"> <li>1. Improper use of controls.</li> <li>2. Worn, broken, or misadjusted drive belt(s).</li> <li>3. Internal transmission wear or damage.</li> <li>4. Bolt loose in transmission pulley.</li> </ol>	<ol style="list-style-type: none"> <li>1. Review Sections 3 and 4.</li> <li>2. See "Checking Drive Belt Tension," Section 5.</li> <li>3. Contact local dealer or the factory.</li> <li>4. Tighten bolt.</li> </ol>
<b>Tines turn, but wheels don't.</b>	<ol style="list-style-type: none"> <li>1. Wheel Drive Pins not in WHEEL DRIVE.</li> <li>2. Internal transmission wear or damage.</li> </ol>	<ol style="list-style-type: none"> <li>1. See "Wheel Drive Pins" in Section 3.</li> <li>2. Contact local Dealer or the Factory.</li> </ol>
<b>Wheels Turn, but Tines Don't.</b>	<ol style="list-style-type: none"> <li>1. Tine holder mounting hardware missing.</li> <li>2. Internal transmission wear or damage.</li> </ol>	<ol style="list-style-type: none"> <li>1. Replace hardware.</li> <li>2. Contact local Dealer or the Factory.</li> </ol>
<b>Poor tilling performance.</b>	<ol style="list-style-type: none"> <li>1. Worn tines.</li> <li>2. Improper Depth Regulator setting.</li> <li>3. Incorrect throttle setting.</li> <li>4. Forward Drive Belt slipping.</li> </ol>	<ol style="list-style-type: none"> <li>1. See "Tines" (Section 5).</li> <li>2. See "Tilling Tips &amp; Techniques," Section 4.</li> <li>3. See Section 4.</li> <li>4. See "Checking Forward Drive Belt Tension," Section 5.</li> </ol>



TINE HOOD, DEPTH REGULATOR LEVER AND DRAG STAKE

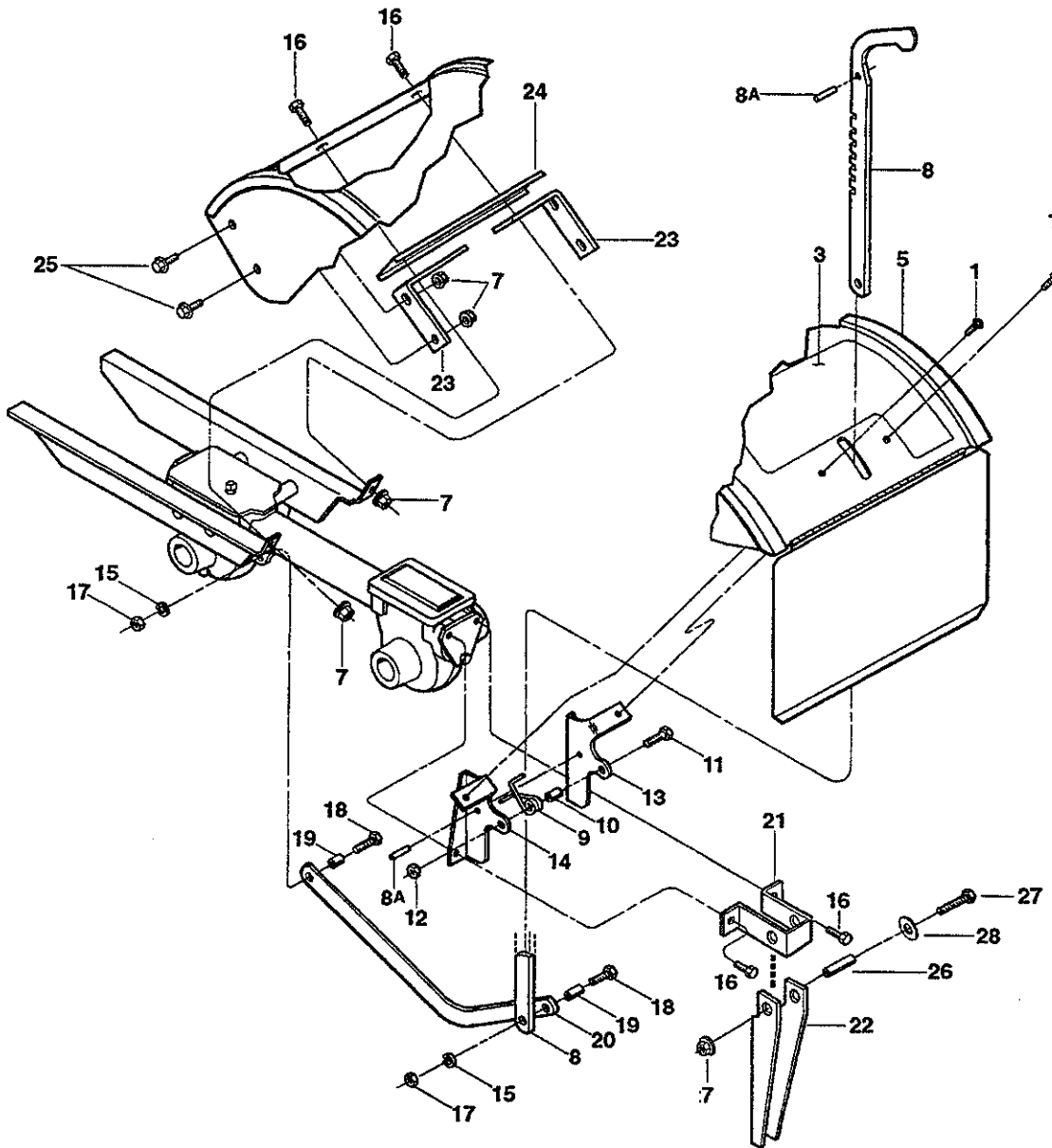

REF. No.	PART No.	DESCRIPTION	QTY.
1	9552	Flange Screw, Self-Tapping, 1/4-20 x 1/2 .....	2
3	1917536	Decal, Hood .....	1
5	1917120	Tine Hood (incl. tine flap and Ref. 3) ..	1
7	1186391	Flange Lock Nut, 5/16-18.....	9
8	1916118001	Depth Regulator Lever .....	1
8A	9308	Spiral Pin .....	2
9	9384	Spring, Depth Regulator .....	1
10	9534	Spacer .....	1
11	1100069	Hex Hd. Screw, 1/4-20 x 1 .....	1
12	9811	Hex Lock Nut, 1/4-20.....	1
13	1916119001	Hood Bracket, Right Hand.....	1
14	1916120001	Hood Bracket, Left Hand .....	1
15	1100242	Lockwasher, 5/16.....	2

REF. No.	PART No.	DESCRIPTION	QTY.
16	1186331	Flange Hd. Screw, 5/16-18 x 1 .....	4
17	1186230	Hex Nut, 5/16-18.....	2
18	1100808	Hex Hd. Screw, 5/16-18 x 1-1/4.....	2
19	55088	Bushing.....	2
20	1916121001	Drag Bar.....	1
21	1916569001	Bracket, Stop .....	1
22	1916570001	Reverse Arm (Drag Stake) .....	1
23	1916708001	Bracket, Hood Support.....	2
24	1916707001	Bracket, Support Channel .....	1
25	1186328	Hex Hd. Screw, 5/16-18 x 5/8 .....	6
26	1916771	Spacer.....	1
27	1111607	Hex Hd. Screw, 5/16-18 x 2-1/4.....	1
28	1107382	Washer, 5/16 I.D. ....	1

## HANDLEBARS, CLUTCH CABLES AND HANDLEBAR MOUNTING HARDWARE

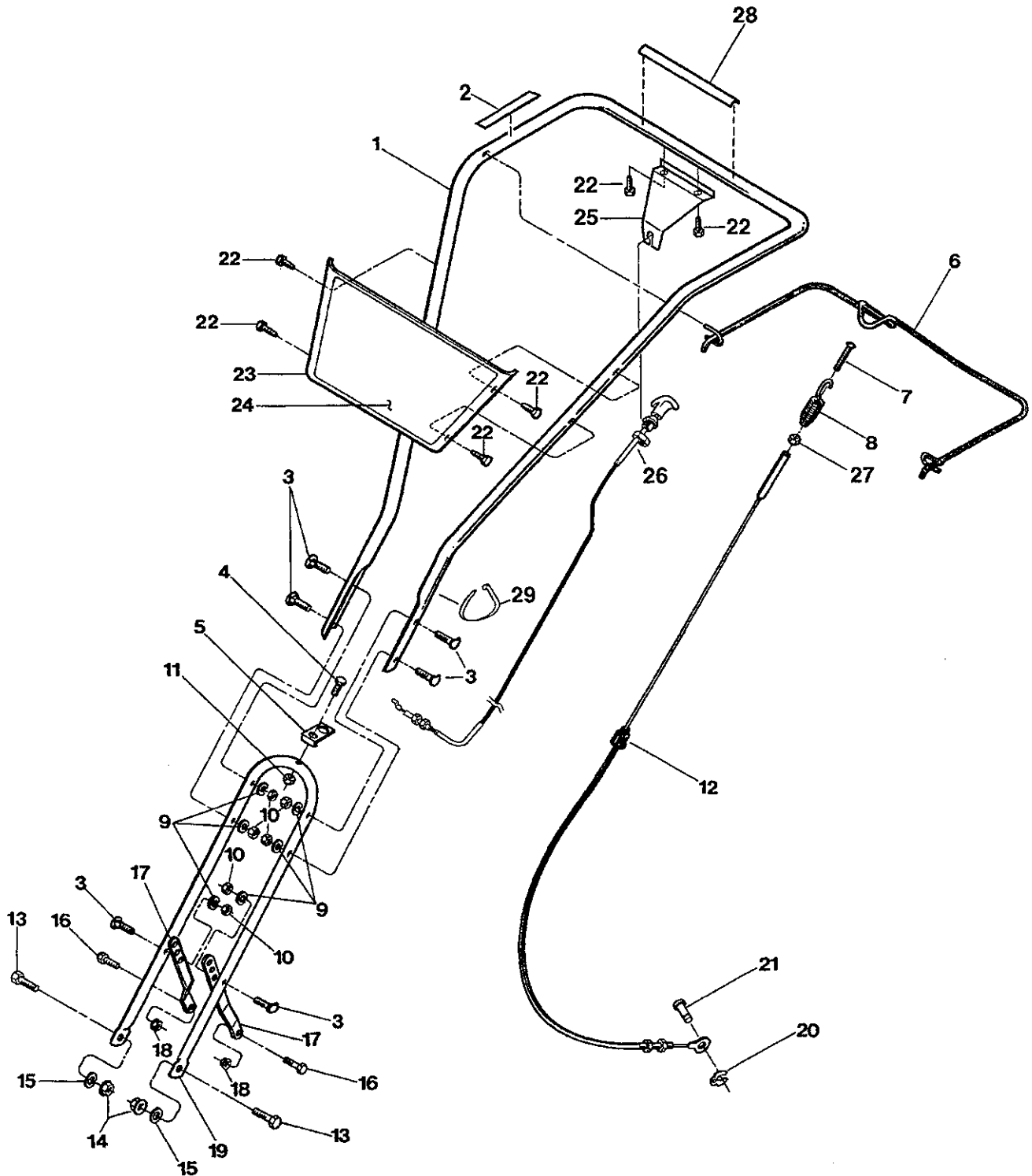

## HANDLEBARS, CLUTCH CABLES AND HANDLEBAR MOUNTING HARDWARE

REF. No.	PART No.	DESCRIPTION	QTY.	REF. No.	PART No.	DESCRIPTION	QTY.
1	1916996	Upper Handlebar (Incl. Refs. 2 & 28) ..	1	16	1100044	Hex Hd. Screw, 5/16-18 x 3/4.....	2
2	1916928	Decal, Forward Clutch Bail .....	1	17	1902173001	Handlebar Support .....	2
3	9854	Curved Hd. Screw, 5/16-18 x 1-1/2 .....	6	18	1110107	Hex Lock Nut, 5/16-18.....	2
4	1100806	Hex Hd. Screw, 1/4-20 x 1-1/4 .....	1	19	1902174001	Lower Handlebar .....	1
5	55044	Bracket, Forward Clutch Cable.....	1	20	9386	Klip Ring.....	1
6	1916106001	Bail, Forward Clutch .....	1	21	9856	Clevis Pin.....	1
7	9855	Screw, #10-24 x 2 .....	1	22	9552	Hex Hd. Screw, 1/4-20 x 1/2, Self-Tapping. ....	6
8	1916712	Spring, Forward Clutch.....	1	23	1901273001	Panel .....	1
9	1100242	Lockwasher, 5/16 .....	6	24	1917559	Decal, Logo .....	1
10	1186230	Hex Nut, 5/16-18 .....	6	25	1916674001	Bracket, Reverse Clutch Cable .....	1
11	9811	Hex Lock Nut, 1/4-20.....	1	26	1916719	Cable Assembly, Reverse Clutch.....	1
12	55048	Cable Assembly, Forward Clutch .....	1	27	1186227	Hex Nut, #10-24 .....	1
13	1100068	Hex Hd. Screw, 3/8-16 x 3/4.....	2	28	1916929	Decal, Reverse Drive Control .....	1
14	9837	Hex Lock Nut, 3/8-16.....	2	29	1735531	Cable Tie.....	2
15	1107383	Flat Washer, 3/8 .....	2				

**ENGINE, ENGINE BRACKETS AND BELT DRIVE SYSTEMS**

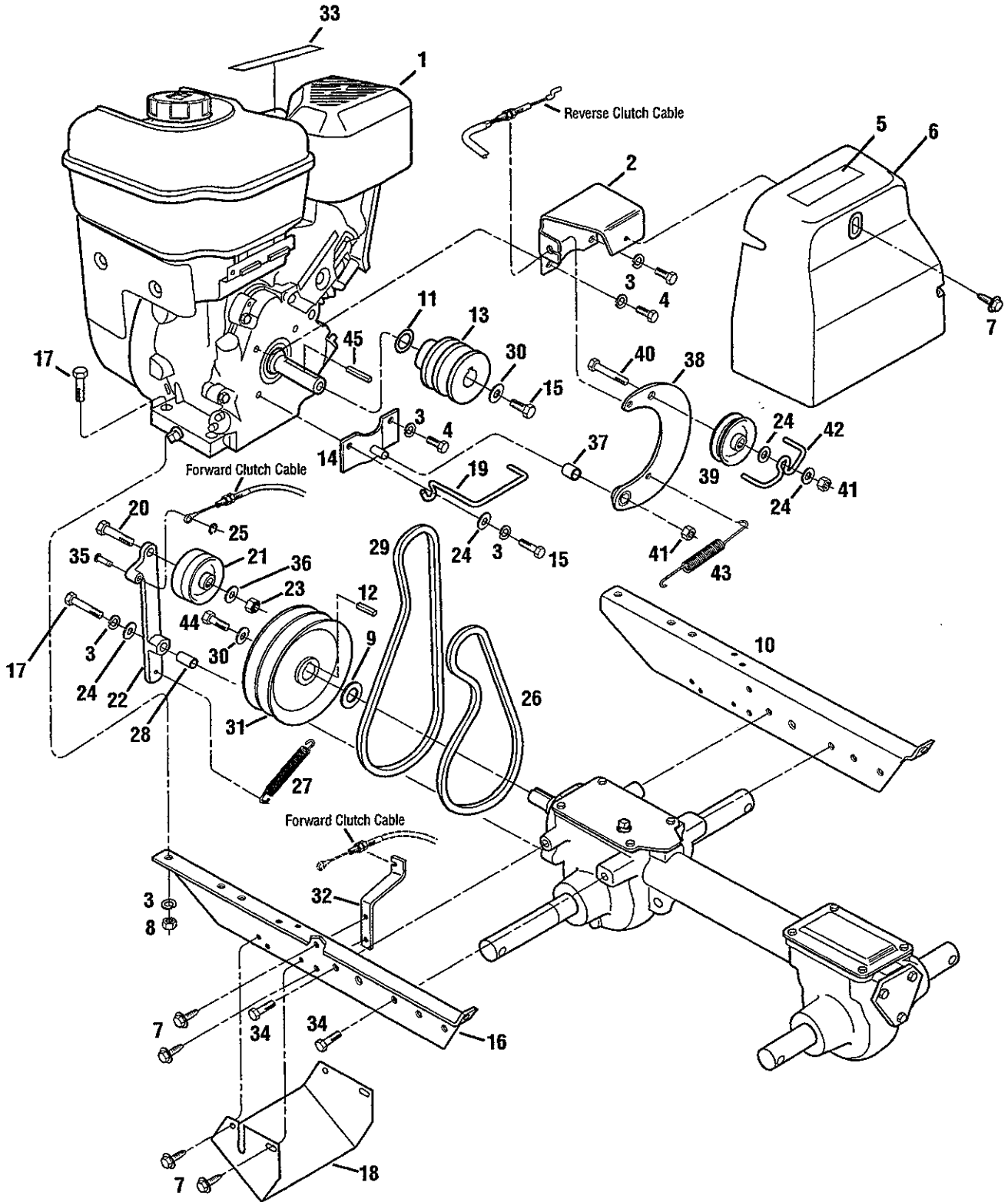

**ENGINE, ENGINE BRACKETS AND BELT DRIVE SYSTEMS**

REF. No.	PART No.	DESCRIPTION	QTY.	REF. No.	PART No.	DESCRIPTION	QTY.
1	*	Engine – 5.5HP or 6.5HP Recoil Start.	1	23	1110108	Lock Nut, 3/8-16 .....	1
2	1916537001	Bracket, Belt Cover .....	1	24	1107382	Flat Washer .....	2
3	1100242	Lockwasher, 5/16 .....	9	25	9386	Klip Ring .....	1
4	1111696	Hex Hd. Screw, 5/16-24 x 1/2 .....	3	26	1916657	Forward Drive Belt .....	1
5	1904557	Decal, Warning - Hot Surfaces .....	1	27	55034	Spring, Forward Return .....	1
6	1917128	Belt Cover (Incl. Ref. 5) .....	1	28	55033	Bushing, Forward Idler Lever .....	1
7	9552	Flange Screw, Self-Tapping, 1/4-20 x 1/2 .....	7	29	1916658	Reverse Drive Belt .....	1
8	1186230	Hex Nut, 5/16-18 .....	4	30	9944	Belleville Washer .....	1
9	50027	Support Washer .....	1	31	1916532	Transmission Pulley .....	1
10	1916795001	Engine Bracket, Right .....	1	32	1916117001	Bracket, Cable Mounting .....	1
11	1138-2	Shim .....	A/R	33	1900766	Decal, Stabilization .....	1
12	9301	Key, 3/16 x 1 .....	1	34	1186328	Hex Hd. Screw, 5/16-18 x 5/8 .....	4
13	1916531	Engine Drive Pulley .....	1	35	9856	Clevis Pin .....	1
14	1916559001	Bracket, Reverse Idler .....	1	36	1107383	Flat Washer, 3/8 .....	1
15	1100005	Hex Hd. Screw, 5/16-24 x 1 .....	3	37	1916536	Bushing .....	1
16	1916794001	Engine Bracket, Left .....	1	38	1916578001	Reverse Idler Arm .....	1
17	1100799	Hex Hd. Screw, 5/16-18 x 1-1/2 .....	5	39	1916535	Reverse Idler Pulley .....	1
18	1916652001	Guard, Belts/Pulleys .....	1	40	1111606	Hex Hd. Screw, 5-16-18 x 2 .....	1
19	1916726	Belt Guide, Forward .....	1	41	1110107	Lock Nut, 5-16-18 .....	2
20	9558	Hex Hd. Screw, 3/8-16 x 1-1/2 .....	1	42	1916725	Belt Guide .....	1
21	9090	Forward Idler Pulley .....	1	43	1916724	Spring, Reverse Return .....	1
22	1916116001	Forward Idler Lever .....	1	44	9572	Hex Hd. Screw, 5/16-18 x 1-1/8 .....	1
				45	1108841	Key, 3/16 x 1-1/2 .....	1

A/R – As Required

\* Contact your local authorized engine service dealer for engine parts and service.  
Refer to your engine nameplate for engine model/type number.

## DRIVE SHAFT ASSEMBLY

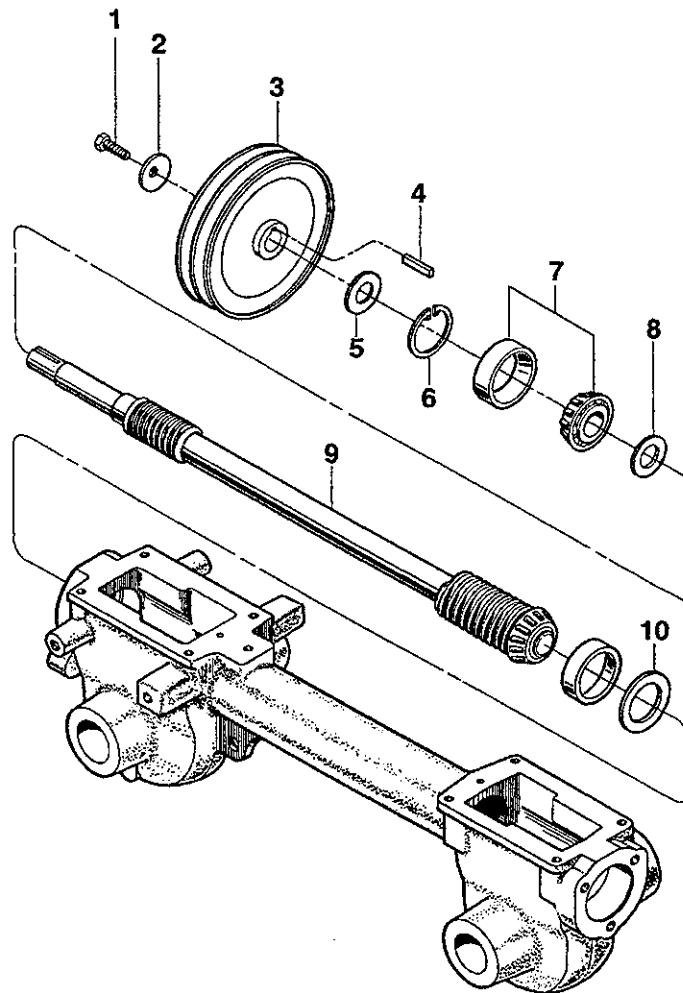

REF. No.	PART No.	DESCRIPTION	QTY.	REF. No.	PART No.	DESCRIPTION	QTY.
1	1100005	Screw, Hex Hd., 5/16-24 x 1, Grade 5.....	1	10	1224-1	Shim, Rear Bearing Cap, .010" thick .....	A/R
2	9944	Belleville Washer .....	1		1224-2	Shim, same as above, except .030" thick .....	A/R
3	1916532	Transmission Pulley, Double Groove.....	1		1224-3	Shim, same as above, except .005" thick.....	A/R
4	9301	Key, 3/16 x 1 .....	1		1224-4	Shim, Same as above except .062" thick.....	A/R
5	50027	Support Washer, Front.....	1		1325C	Shim Set (Incl. the following shims: two #1224-1, two #1224-2, one #1224-3 and one #1224-4).....	A/R
6	9517	Snap Ring.....	1				
7	1714	Bearing, Tapered Roller (with race).....	2				
8	50043	Support Washer, Rear.....	1				
9	1916936	Drive Shaft Assembly.....	1				

A/R - As Required

WHEEL AND TILLER SHAFT ASSEMBLIES

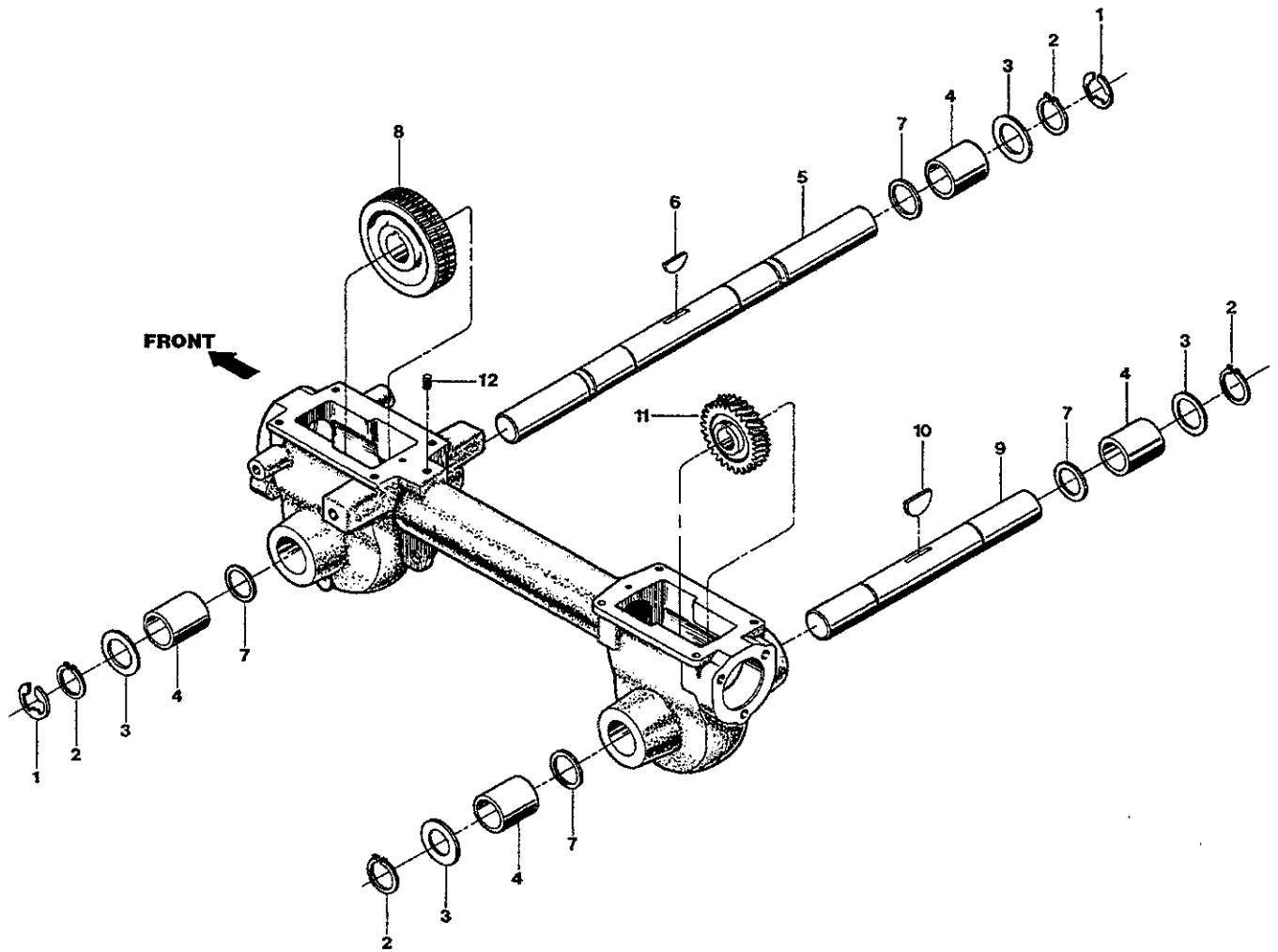

REF. No.	PART No.	DESCRIPTION	QTY.
1	9512	Retainer, Snap Ring, "E" Type.....	2
2	9511	Retainer, Snap Ring .....	4
3	1166-1	Shim, 0.062" Thick.....	A/R
	1166-2	Shim, 0.030" Thick.....	A/R
	1166-3	Shim, 0.015" Thick.....	A/R
	1166-4	Shim, 0.010" Thick.....	A/R
	1166-5	Shim, 0.005" Thick.....	A/R
4	1086	Bushing, Bronze .....	4

REF. No.	PART No.	DESCRIPTION	QTY.
5	1916741	Wheel Shaft.....	1
6	9305	Hi-Pro Key, 1/4 x 1 .....	1
7	1132-2	Spacer .....	4
8	1904278	Worm Gear, Wheel Shaft.....	1
9	1915074	Tiller Shaft.....	1
10	1104	Woodruff Key .....	1
11	1916542	Worm Gear .....	1

A/R – As Required

**TRANSMISSION HOUSING, COVERS, SEALS, GASKETS AND PLUG**

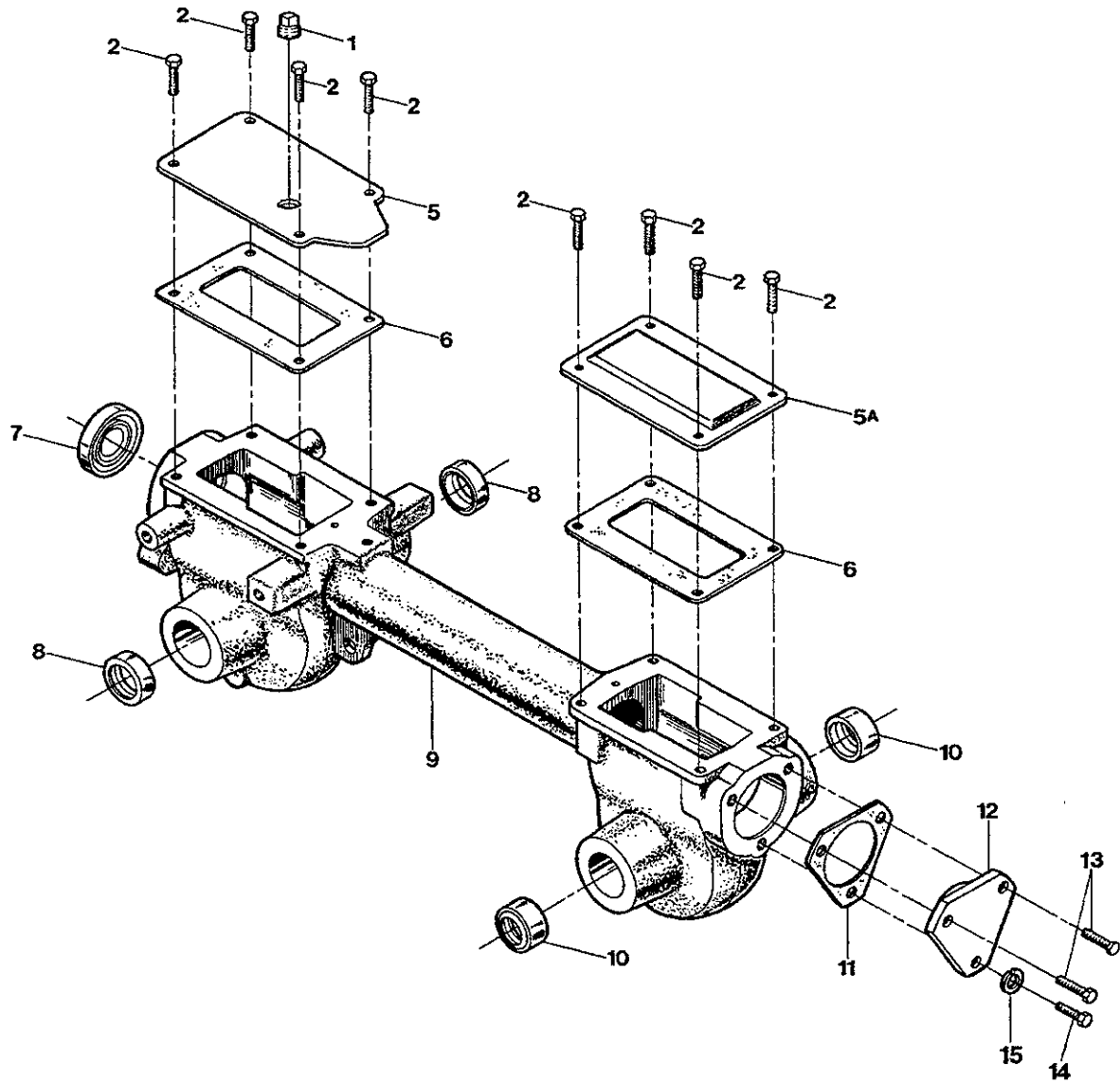



**TRANSMISSION HOUSING, COVERS, SEALS, GASKETS AND PLUG**

REF. No.	PART No.	DESCRIPTION	QTY.	REF. No.	PART No.	DESCRIPTION	QTY.
1	9727	Plug, Transmission Oil Fill .....	1	10	1909374	Oil Seal, Tine Shaft .....	2
2	1186328	Flange Screw, Grade 5, 5/16-18 x 5/8.	8	11	55011-1	Gasket, Bearing Cap (.010" thick) .....	1
5	1916641001	Front Cover, Transmission .....	1		55011-2	Gasket, Bearing Cap (.030" thick).....	1
5A	50074	Rear Cover, Transmission.....	1	12	1916111001	Rear Bearing Cap .....	1
6	50032	Gasket, Housing Cover.....	2	13	1186331	Flange Screw, 5/16-18 x 1 .....	2
7	9617	Oil Seal, Drive Shaft .....	1	14	1100044	Flange Screw, 5/16-18 x 3/4 .....	1
8	9621	Oil Seal, Wheel Shaft.....	2	15	1100242	Lockwasher, 5/16.....	1
9	1916975001	Transmission Housing Assembly .....	1				

## TINES

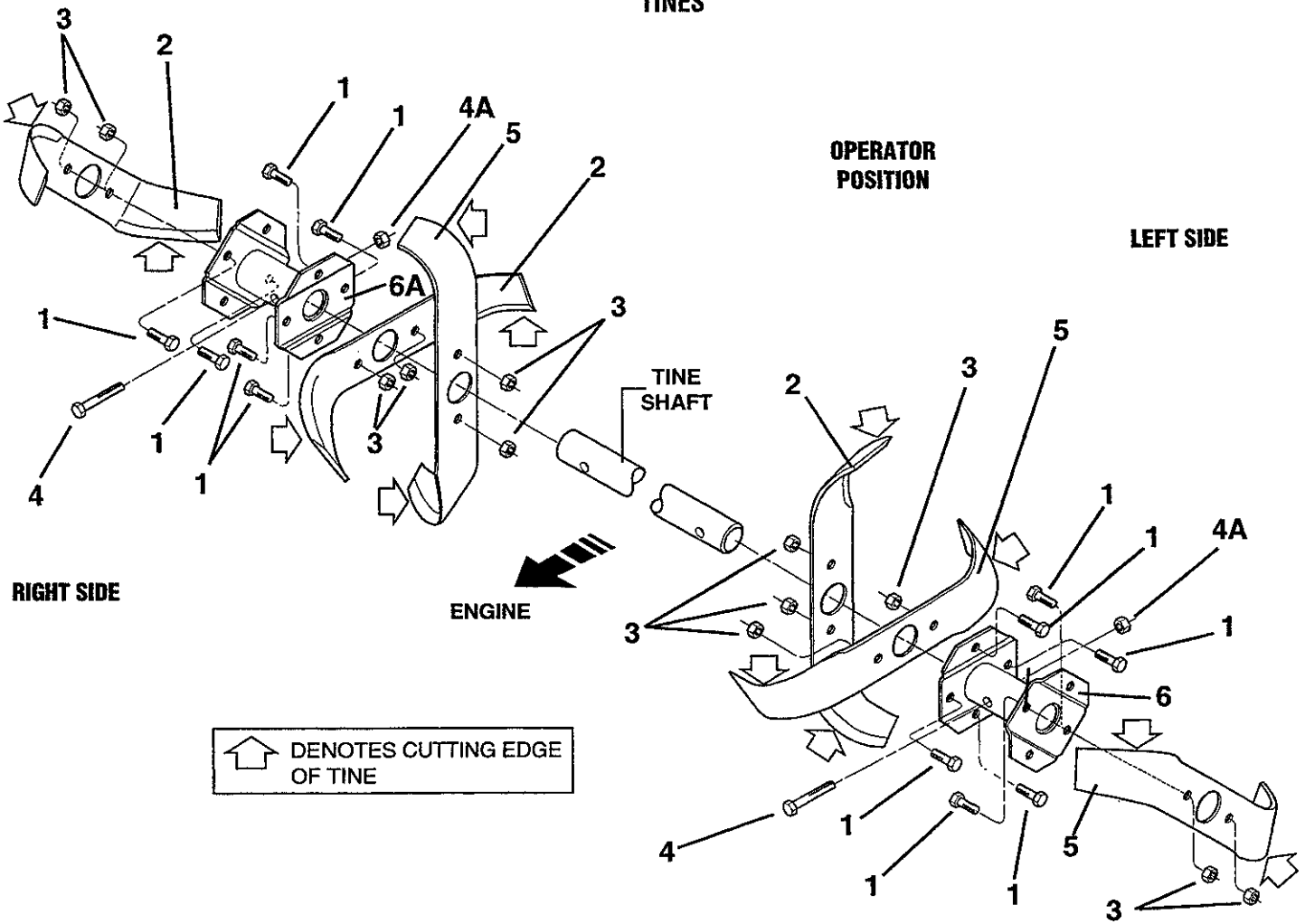

MOUNT TINES SO THE CUTTING EDGE AT THE TOP OF EACH TINE FACES THE OPERATOR

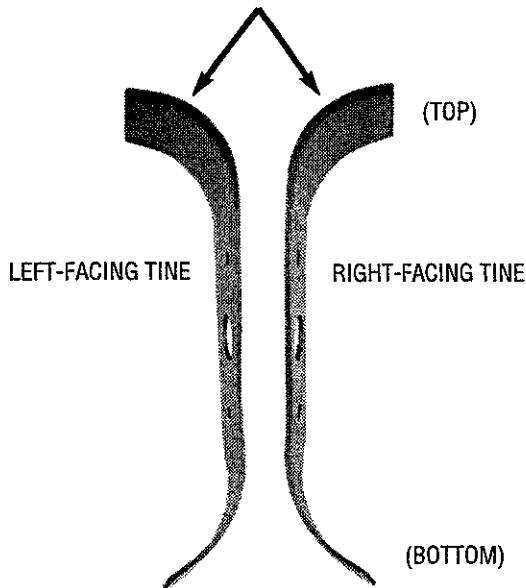

**IMPORTANT:** LEFT AND RIGHT SIDES OF TILLER ARE DETERMINED BY STANDING IN THE OPERATOR POSITION (BEHIND THE HOOD) AND FACING THE DIRECTION OF FORWARD TRAVEL.

## TINES

REF No.	PART No.	DESCRIPTION	QTY.
1	1100044	Hex Hd. Screw, 5/16-18 x 3/4, Grade 5	12
2	1817060	Tine - Twin-Edged, Left-Facing.....	3
3	1732499	Hex Lock Nut, 5/16-18.....	12
4	1982612	Hex Hd. Screw, 3/8-16 x 2.....	2
---	1916783	Tine Replacement Set - (Incl. three right-facing tines, three left-facing tines; and assembly hardware.....	1
4A	1733398	Hex Lock Nut, 3/8-16.....	2
5	1817059	Tine - Twin-Edged, Right-Facing.....	3
6	1916702001	Tine Holder - Left Side (A).....	1
	1916704001	Tine Holder - Left Side (B).....	1
6A	1916703001	Tine Holder- Right Side (A).....	1
	1916705001	Tine Holder- Right Side (B).....	1

(A) Model 12214 - 5.5 HP  
 (B) Model 12193 - 6.5 HP

**WHEELS**

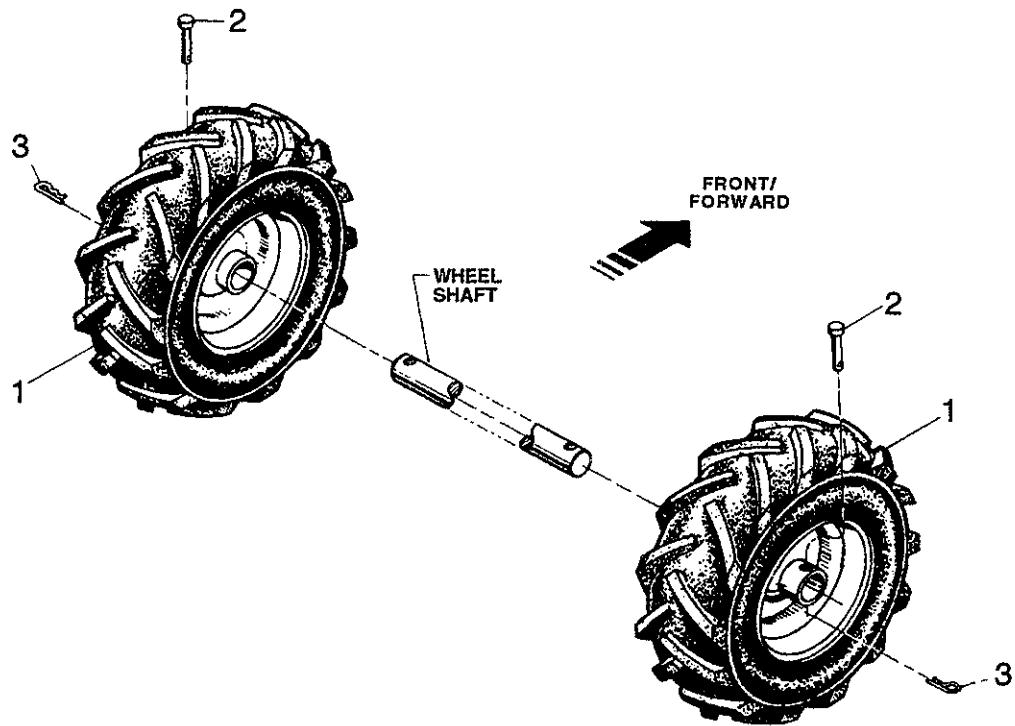

REF No.	PART No.	DESCRIPTION	QTY.
1	1917486	Wheel & Tire Assembly.....	2
2	9380	Clevis Pin, .312 x 1-3/4.....	2
3	9338	Hair Pin Cotter .....	2

# CUSTOMER SERVICE INFORMATION

## Owner Registration Card

Please fill out and mail the enclosed owner registration card. The purpose of this card is to register each unit at the factory so that we can provide you with warranty benefits and informational bulletins.

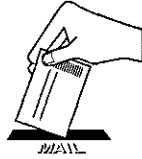

## Warranty Service

The warranty statement is included in the unit's literature package.

## Model/Serial Numbers

A Model/Serial Numbers decal is located on top of the transmission. For ready reference, record these numbers in the spaces below.

Date of Purchase: \_\_\_\_\_

Model/Serial Numbers: \_\_\_\_\_

## Authorized Dealer Information

If you purchased your unit from an authorized dealer, record the dealer's address and phone number below for ready reference:

Dealer Name: \_\_\_\_\_

Address: \_\_\_\_\_

Phone: \_\_\_\_\_

### IMPORTANT:

Left and right sides of the unit are determined by standing behind the unit, in the operator's position, and facing in the direction of forward travel.

### NOTICE:

We reserve the right to change specifications, add improvements or discontinue the manufacture of any of our equipment without notice or obligation to purchasers of our equipment.

## Customer Service and Technical Service

If you have questions or problems with the unit, contact your local dealer or the factory. (When calling or writing, provide the Model/Serial Numbers of the unit.)

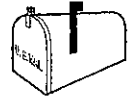

## Replacement Parts

Factory specified replacement parts are available from your authorized dealer or directly from the factory. When ordering parts, be sure to provide the following:

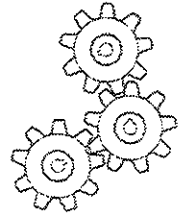

- Model/Serial Numbers of the unit.
- Part number of the part needed.
- Part Description.
- Quantity needed.

NOTE: All replacement parts must conform to our rigid quality specifications. Although some replacement parts we provide may vary slightly in shape, color or texture from the original parts, any variations will not affect the fit or performance of these parts on your unit.

## Engine Service and Repair

For engine service or repair, contact your nearest authorized engine dealer (look in the Yellow Pages under "Engines—Gasoline"). The engine is warranted by the engine manufacturer. Any unauthorized work performed on the engine during the warranty period may void this warranty. For complete details on the engine warranty, refer to the engine owner manual.

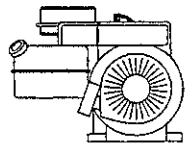

### WARNING

We urge using only genuine replacement parts, which meet all the latest requirements. Replacement parts manufactured by others could present safety hazards, even though they may fit on the unit.

*For customer assistance, contact your nearest authorized dealer or:*

**GARDEN WAY INCORPORATED** • 1 Garden Way • Troy, New York 12180

Customer Service: 1-800-437-8686 • Technical Service: 1-800-520-5520 • Parts Service: 1-800-648-6776

• FAX: (518) 391-7332 • WEBSITE: [www.troybilt.com](http://www.troybilt.com)

Outside the United States and Canada:

Customer Service: (518) 391-7007 • Technical Service: (518) 391-7008 • Parts Service: (518) 391-7006 • FAX (518) 391-7332

## Free Manuals Download Website

<http://myh66.com>

<http://usermanuals.us>

<http://www.somanuals.com>

<http://www.4manuals.cc>

<http://www.manual-lib.com>

<http://www.404manual.com>

<http://www.luxmanual.com>

<http://aubethermostatmanual.com>

Golf course search by state

<http://golfingnear.com>

Email search by domain

<http://emailbydomain.com>

Auto manuals search

<http://auto.somanuals.com>

TV manuals search

<http://tv.somanuals.com>