

# **TROY-BILT**<sup>®</sup>

## Operator's Manual

### **PRO Line**

Rear-tine Tiller Model  
675B—Pony<sup>®</sup>

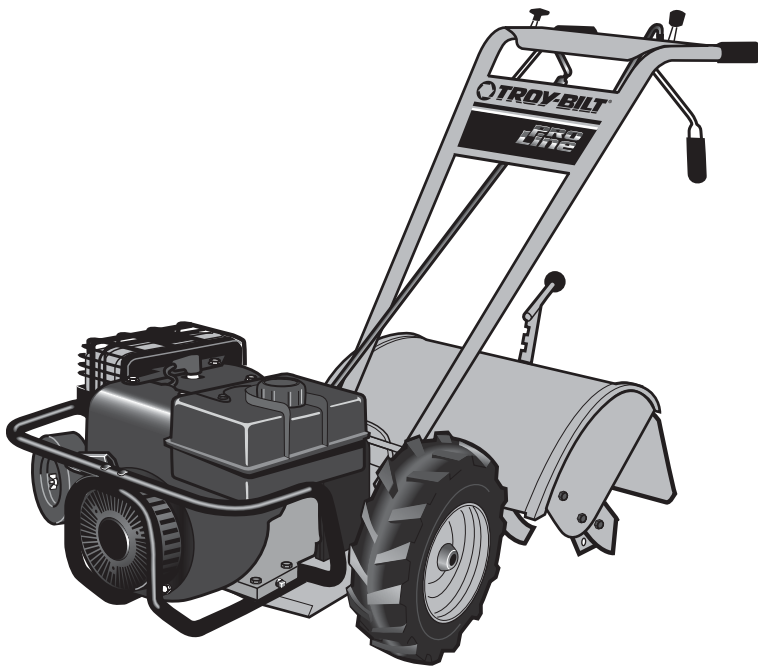

Model 675B Shown (bumper styles vary)

### **IMPORTANT: READ SAFETY RULES AND INSTRUCTIONS CAREFULLY**

**WARNING:** This unit is equipped with an internal combustion engine and should not be used on or near any unimproved forest-covered, brush-covered or grass-covered land unless the engine's exhaust system is equipped with a spark arrester meeting applicable local or state laws (if any). If a spark arrester is used, it should be maintained in effective working order by the operator. In the State of California the above is required by law (Section 4442 of the California Public Resources Code). Other states may have similar laws. Federal laws apply on federal lands. A spark arrester for the muffler is available through your nearest engine authorized service dealer or contact the service department, P.O. Box 361131 Cleveland, Ohio 44136-0019.

**TROY-BILT LLC, P.O. BOX 361131 CLEVELAND, OHIO 44136-0019**

PRINTED IN U.S.A.

FORM NO. 769-00586A  
9/22/03

## TABLE OF CONTENTS

Content	Page	Content	Page
Customer Support	2	Maintenance	16
Safety	3	Off-season Storage	18
Assembly	6	Troubleshooting	23
Features and Controls	9	Parts List	24
Operation	11	Warranty Information	Back Cover

## FINDING MODEL NUMBER

This Operator's Manual is an important part of your new rear-tine tiller. It will help you assemble, prepare and maintain the unit for best performance. Please read and understand what it says.



**Before you start assembling your new equipment**, please locate the model plate on the equipment and copy the information from it in the space provided below. A sample model plate is also given below. You can locate the model plate by standing behind the unit and looking down at rear surface of the tine shield. This information will be necessary to use the manufacturer's web site and/or help from the Customer Support Department or an authorized service dealer.

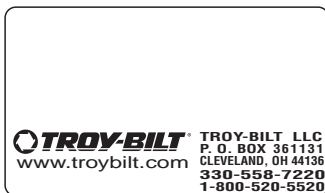

Copy the model number here: \_\_\_\_\_

Copy the serial number here: \_\_\_\_\_

## CUSTOMER SUPPORT

**Please do NOT return the unit to the retailer from where it was purchased, without first contacting Customer Support.**

If you have difficulty assembling this product or have any questions regarding the controls, operation or maintenance of this unit, you can seek help from the experts. Choose from the options below:

	<p>Visit <b>troy-bilt.com</b> for many useful suggestions. Click on Customer Support button and you will get the four options reproduced here. Click on the appropriate button and help is immediately available.</p> <div style="text-align: center; border: 1px solid black; padding: 5px; margin: 10px auto; width: 80%;"> <p><b>Find Answers</b> Click here to search our knowledge base. Search by product, keyword, or phrase.</p> <p><b>My Stuff</b> Login to check the status of your questions, modify your inquiries, or update your personal profile.</p> <p><b>Service Locator</b> Need local assistance? Click here to find authorized service centers in your area.</p> <p><b>Manuals Online</b> Need a manual and/or parts list? Download literature from recent model years.</p> </div> <p style="text-align: center;"><i>The answer you are looking for could be just a mouse click away!</i></p>	<p><i>The answer you are looking for could be just a mouse click away!</i></p>
	<p>If you prefer to reach a Customer Support Representative, please call <b>1(800) 520-5520</b>.</p>	
	<p>The <b>engine</b> manufacturer is responsible for all engine-related issues with regards to performance, power-rating, specifications, warranty and service. Please refer to the engine manufacturer's Owner's/Operator's Manual, packed separately with your unit, for more information.</p>	

## Training

1. Carefully read this Owner's Manual, the separate Engine Owner's Manual, and any other literature you may receive. Be thoroughly familiar with the controls and the proper use of the tiller and its engine. Know how to stop the unit and disengage the controls quickly.
2. Never allow children to operate the tiller. Never allow adults to operate the tiller without proper instruction.
3. Keep the area of operation clear of all persons, particularly children and pets.
4. Keep in mind that the operator or user is responsible for accidents or hazards occurring to other people, their property, and themselves.

## Preparation

1. Thoroughly inspect the area where the tiller is to be used and remove all foreign objects.
2. Be sure all control levers are released and the Wheel Gear Lever is in ENGAGE position before starting the engine.

3. Do not operate the tiller without wearing adequate outer garments. Avoid loose garments or jewelry that could get caught in moving parts.

4. Do not operate the tiller when barefoot or wearing sandals, sneakers, or light footwear. Wear protective footwear that will improve footing on slippery surfaces.

5. Do not till near underground electric cables, telephone lines, pipes or hoses. If in doubt, contact your telephone or utility company.

6. Warning: Handle fuel with care; it is highly flammable and its vapors are explosive. Take the following precautions:

- a. Store fuel in containers specifically designed for this purpose.

5. If the unit should start to vibrate abnormally, stop the engine, disconnect the spark plug wire and prevent it from touching the spark plug, and check immediately for the cause. Vibration is generally a warning of trouble.

6. Stop the engine, disconnect the spark plug wire and prevent it from touching the spark plug whenever you leave the operating position, before unclogging the tines, or when making any repairs, adjustments or inspections.

7. Take all possible precautions when leaving the machine unattended. Stop the engine. Disconnect spark plug wire and move it away from the spark plug. Move Wheel Gear Lever to ENGAGE.

8. Before cleaning, repairing, or inspecting, stop the engine and make certain all moving parts have stopped. Disconnect the spark plug wire and prevent it from touching the spark plug to prevent accidental starting.

9. Always keep the tiller tine hood flap down.

10. Never use the tiller unless proper guards, plates, or other safety protective devices are in place.

11. Do not run engine in an enclosed area. Engine exhaust contains carbon monoxide gas, a deadly poison that is odorless, colorless, and tasteless.

12. Keep children and pets away.

13. **Never operate the tiller under engine power if the Wheel Gear Lever is in DIS-ENGAGE (FREEWHEEL). In this position, the wheels will not hold the tiller back and the revolving tines could propel the tiller rapidly backward, possibly causing loss of control.** Always move the Wheel Gear Lever to ENGAGE before starting the engine or engaging the tines/wheels with the Forward Clutch or the Reverse Clutch.

14. Be aware that the tiller may unexpectedly bounce upward or jump backward if the tines should strike extremely hard packed soil, frozen ground, or buried obstacles like large stones, roots, or stumps. If in doubt about the tilling conditions, always use the following operating precautions to assist you in maintaining control of the tiller:

a. **Walk behind and to one side of the tiller, using one hand on the handlebars. Relax your arm, but use a secure hand grip.**

b. **Use slower engine speeds.**

c. **Clear the tilling area of all large stones, roots and other debris.**

d. **Avoid using downward pressure on handlebars. If need be, use slight upward pressure to keep the tines from digging too deeply.**

e. **Before contacting hard packed soil at the end of a row, reduce engine speed and lift handlebars to raise tines out of the soil.**

f. **In an emergency, stop tines and wheels by releasing whichever Clutch Lever is engaged. Do not attempt to restrain the tiller.**

15. Do not overload the tiller's capacity by attempting to till too deeply at too fast a rate.

16. Never operate the tiller at high transport speeds on slippery surfaces. Look behind and use care when backing up.

17. Do not operate the tiller on a slope that is too steep for safety. When on slopes, slow down and make sure you have good footing. Never permit the tiller to freewheel down slopes.

18. Never allow bystanders near the unit.

19. Only use attachments and accessories that are approved by Garden Way Inc.

20. Use tiller attachments and accessories when recommended.

21. Never operate the tiller without good visibility or light.

22. Never operate the tiller if you are tired, or under the influence of alcohol, drugs or medication.

23. Operators shall not tamper with the engine-governor settings on the machine; the governor controls the maximum safe operating speed to protect the engine and all moving parts from damage caused by overspeed. Authorized service shall be sought if a problem exists.

24. Do not touch engine parts which may be hot from operation. Let parts cool down

25. Please remember: You can always stop the tines and wheels by releasing the Forward Clutch Lever or the Reverse Clutch Control (whichever lever you have engaged) or by moving the Throttle Control Lever to STOP.

26. To load or unload the tiller, see the instructions in Section 4 of this Manual.

27. Use extreme caution when reversing or pulling the machine towards you.

28. Start the engine carefully according to instructions and with feet well away from the tines.

29. Never pick up or carry a machine while the engine is running.

## Maintenance and Storage

1. Keep the tiller, attachments and accessories in safe working condition.

2. Check all nuts, bolts, and screws at frequent intervals for proper tightness to be sure the equipment is in safe working condition.

3. Never store the tiller with fuel in the fuel tank inside a building where ignition sources are present such as hot water and space heaters, furnaces, clothes dryers, stoves, electric motors, etc.). Allow engine to cool before storing in any enclosure.

4. To reduce the chances of a fire hazard, keep the engine free of grass, leaves, or excessive grease.

5. Store gasoline in a cool, well-ventilated area, safely away from any spark- or flame-producing equipment. Store gasoline in an approved container, safely away from the reach of children.

6. Refer to the storage instructions in the Maintenance section of this Manual and the separate Engine Owner's Manual for instructions if the tiller is to be stored for an extended period.

7. Never perform maintenance while the engine is running or the spark plug wire is connected, except when specifically instructed to do so.

8. If the fuel tank has to be drained, do this outdoors.

## Safety Decals

For your safety and the safety of others, various safety and operational decals are located on your unit (see Figure 1-2 below).

Keep the decals clean and legible at all times. Contact your local service dealer or the factory for replacements if any decals are damaged or missing.

Refer to the Parts List in this manual for decal locations, part numbers and ordering instructions.

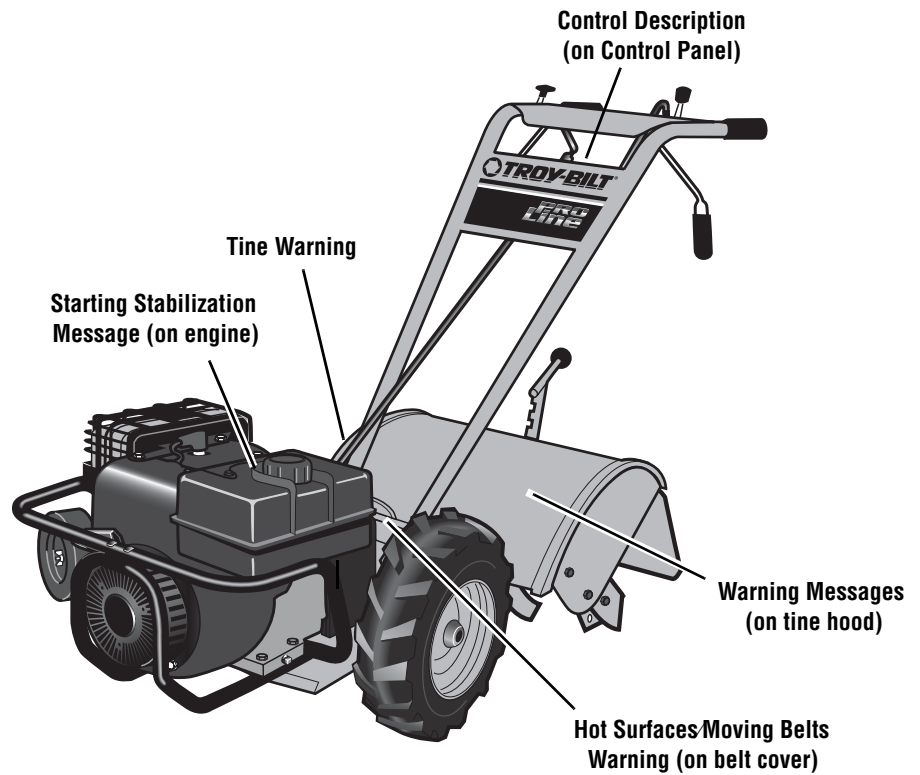

Figure 1-2: Location of Safety and Operating Decals

### Operating Symbols

Various symbols (shown here, with word descriptions) may be used on the tiller and engine.

NOTE: Your unit may not have all of the symbols.



FAST



SLOW



STOP



CHOKE  
ON



CHOKE  
OFF

R

REVERSE



ROTATING TINES



TILLER DIRECTION

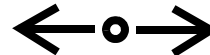

LEVER DIRECTION



# WARNING

TO AVOID SERIOUS INJURY:

- READ THE OPERATOR'S MANUAL.
- KNOW LOCATIONS AND FUNCTIONS OF ALL CONTROLS.
- KEEP ALL SAFETY DEVICES AND SHIELDS IN PLACE AND WORKING.
- NEVER ALLOW CHILDREN OR UNINSTRUCTED ADULTS TO OPERATE TILLER.
- SHUT OFF ENGINE AND DISCONNECT SPARK PLUG WIRE BEFORE MANUALLY UN-CLOGGING TINES OR MAKING REPAIRS.
- KEEP BYSTANDERS AWAY FROM MACHINE.
- KEEP AWAY FROM ROTATING PARTS.
- USE EXTREME CAUTION WHEN REVERSING OR PULLING THE MACHINE TOWARDS YOU.

## SECTION 2: ASSEMBLY



**WARNING:** To prevent personal injury or property damage, do not start the engine until all assembly steps are complete and you have read and understand the safety and operating instructions in this Manual.

### Introduction

Carefully follow these assembly steps to correctly prepare your tiller for use. It is recommended that you read this Section in its entirety before beginning assembly.

### Inspect unit

Inspect the unit and carton for damage immediately after delivery. Contact the carrier (trucking company) if you find or suspect damage. Inform them of the damage and request instructions for filing a claim. To protect your rights, put your claim in writing and mail a copy to the carrier within 15 days after the unit has been delivered. Contact us at the factory if you need assistance in this matter.

### Unpacking and Assembly Instructions

#### STEP1: UNPACKING INSTRUCTIONS

1. Remove any card-board inserts and packaging material from the carton. Remove any staples from the bottom of the carton and remove the carton.
2. Cut the large, plastic tie strap that secures the transmission tube to the shipping pallet. Leave the handlebars on top of the tiller to avoid damaging any cables.
3. A bag with loose hardware is inside the literature envelope. Check the contents against the following list and Figure 2-1. Contact your local dealer or the factory if any items are missing or damaged.  
NOTE: For electric start units, a second hardware bag is located near the battery.
4. The tiller is heavy. You should not attempt to remove it from the shipping platform until instructed to do so in these "Assembly" steps.

### Hardware Bag Parts List

Ref.	Qty.	Description
1	2	3/8-16 x 1" Hex Hd. Screw
2	1	Keyed Washer
3	1	Wheel Gear Lever Knob
4	1	Height Adjustment Flange (See Figure 2-2)
5	2	3/8" Flat Washer
6	2	#10 Lockwasher
7	2	3/8"-16 Nylock Lock Nut
8	2	#10-32 x 1/2" Rnd Hd Screw
9	2	#10-32 Nut
10	1	Cotter Pin (not used)
11	4	Plastic Tie Strap (2 not used)

### Tools / Materials Needed for Assembly

- (1) 3/8" open-end wrench\*
- (2) 9/16" open-end wrench\*
- (1) 7/8" open-end wrench"
- (1) Scissors (to trim plastic ties)
- (1) Ruler
- (1) Small board (to tap plastic knob on lever)
- (1) Tire pressure gauge
- (1) Clean oil funnel
- (1) Clean, high-quality motor oil. Refer to the separate Engine Owner's Manual for motor oil specifications and quantity required.

\* Adjustable wrenches may be used.

**IMPORTANT:** Motor oil must be added to the engine crankcase before the engine is started. Follow the instructions in this "Assembly" Section and in the separate Engine Owner's Manual.

**NOTE:** *LEFT and RIGHT sides of the tiller are as viewed from the operator's position behind the handlebars.*

#### STEP 2: ATTACH HANDLEBARS

1. Cut the large, plastic cable ties that secure the handlebar ends to the handlebar mounting tabs on the transmission top cover.
2. Gently lift handlebar (do not overstretch attached cable) and place handlebar cross-brace (B, Figure 2-3) in front of curved height adjustment bracket (C).

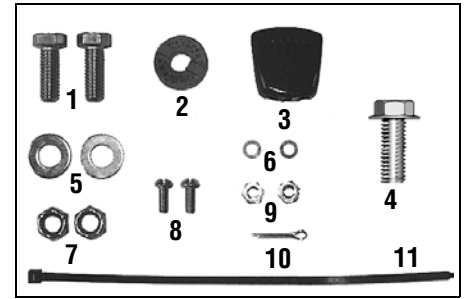

Figure 2-1: Loose hardware (shown in reduced size).

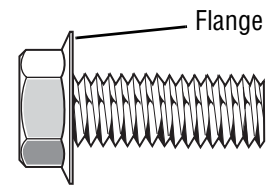

Figure 2-2: Handlebar height adjustment uses the flange head screw.

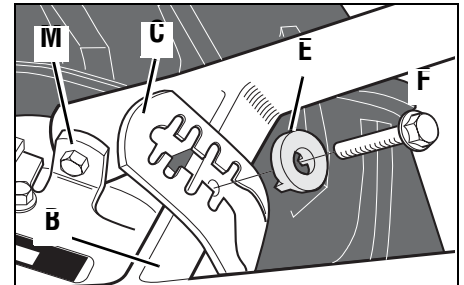
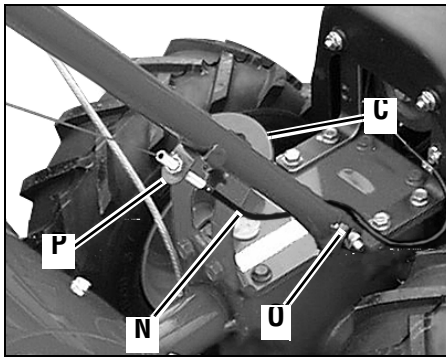

Figure 2-3: Forward clutch control cable not shown for clarity.

**3.** With the forward clutch cable (N, Figure 2-4) on the inside of handlebar, position the handlebar ends on the outside of the two mounting tabs (M, Figure 2-3) on the transmission top cover.

**NOTE:** The curved handlebar height adjustment bracket appears as shown in C, Figure 2-3 for non-electric start units. For electric start units, the bracket is loosened and moved to one side.

**4.** Loosely attach the handlebars to the mounting tabs with two 3/8-16 x 1" screws (heads of screws go to inside of tabs), 3/8" flat washers and 3/8"-16 lock nuts (O, Figure 2-4).

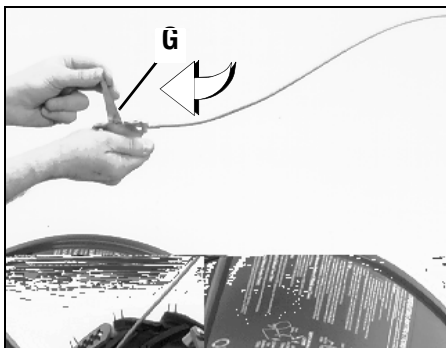

**Figure 2-4: Attach handlebars.**

5. Move the handlebars up or down to align the threaded hole in the cross-brace with one of the four slots in the curved height adjustment bracket. Place the keyed washer (E, Figure 2-3) on the flange head height adjustment screw (F) with the raised keys (edges) of the washer facing down.

6. Thread the height adjustment screw (F, Figure 2-3) into the hole in the handlebar cross-brace, making sure that the raised keys on the washer fit into the slot on the height adjustment bracket. Tighten the height adjustment screw securely. Next, securely tighten the two screws and nuts in the ends of the handlebar (M, Figure 2-3).

7. To remove the tiller from its shipping platform, first carefully unwrap the wheel gear cable (with attached lever - see Figure 2-5) from around the chassis. Move the Wheel Gear Lever (G) to the DISENGAGE position--this allows the wheels to rotate freely. Use the handlebars to roll the tiller off the platform.



**Figure 2-5: Carefully unwrap Wheel Gear Lever and move lever to DISENGAGE.**

**NOTE:** The Wheel Gear Lever will be installed later in this procedure.

**IMPORTANT:** Use the DISENGAGE position only when the engine is not running. Before starting the engine, the Wheel Gear Lever must be placed in the ENGAGE position (see Section 3 for details).

### STEP 3: ATTACH REVERSE CLUTCH CONTROL CABLE

1. Carefully unwrap the reverse clutch control cable (H, Figure 2-6) from its shipping position and route it up along the inside edge of the left side handlebar. A knob and large hex nut (I) is installed on the cable.

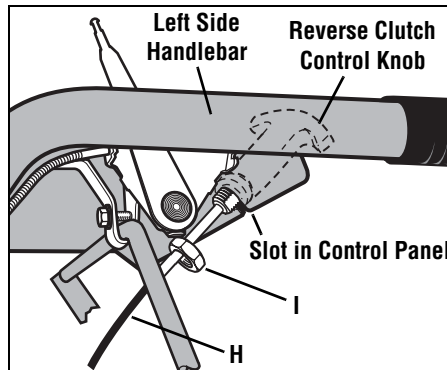

**Figure 2-6: Attach reverse clutch control assembly to slotted hole in handlebar panel.**

2. Insert the cable into the slot in the control panel and fit the threaded assembly into the hole in the slot (see Figure 2-6). Be sure that the flat side of the threaded assembly is aligned with the flat side of the hole. Slide the hex nut (I) up the cable and tighten it securely.

3. Test the function of the reverse clutch control cable by pulling the knob out and releasing it. The knob should return to its neutral position against the tapered bushing. If it doesn't, contact your local dealer or the factory for technical.

### STEP 4: ATTACH FORWARD CLUTCH CONTROL CABLE

1. Remove any fasteners (rubber bands, tape, etc.) that may secure the Forward Clutch Control levers (J, Figure 2-7) to the handlebar.

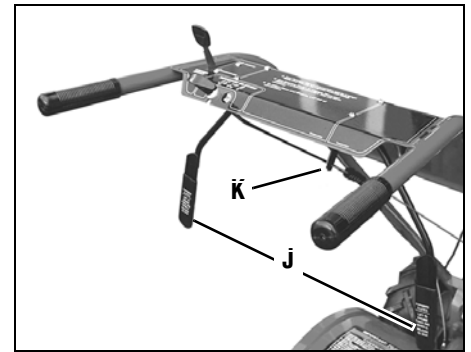

**Figure 2-7: Forward Clutch Control levers (J). Forward clutch control linkage (K).**

2. The forward clutch control cable (with attached spring) is hanging loosely near the right-side wheel. Being careful not to kink or stretch the cable, insert the z-connector (L, Figure 2-8 - end of the spring) into the hole at the end of the forward clutch control linkage (K, Figure 2-7).

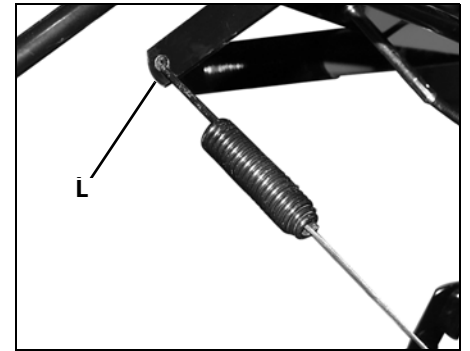

**Figure 2-8**

3. Attach the cable adjuster (A, Figure 2-9) to the bracket on the right-side handlebar. Use two 1/2" wrenches to loosen the two jam nuts (B) just enough to slide the cable adjuster onto the bracket. Then hand tighten the jam nuts.

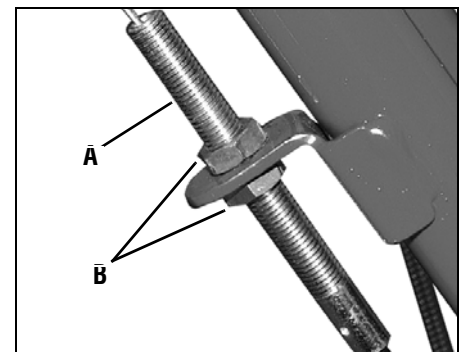

**Figure 2-9**



**CAUTION:** Incorrect cable adjustment could cause the wheels and tines to rotate unexpectedly. Follow adjustment procedures carefully. Failure to do so could result in personal injury or property damage.

4. Check for correct spring cable tension as instructed in Section 5, *Checking and Adjusting Forward Clutch Belt Tension*.
5. When tension is correct, tighten the two jam nuts (B) securely.

#### STEP 5: CHECK TRANSMISSION GEAR OIL LEVEL

The transmission was filled with gear oil at the factory. However, be sure to check the oil level at this time to make certain it is correct.

**IMPORTANT:** Do not operate the tiller if the gear oil level is low. Doing so will result in severe damage to the transmission components.

1. With the tiller on level ground, pull the Depth Regulator Lever (R, Figure 2-13) back and then slide it to the second notch from the top. **NOTE:** If the lever does not move, lift the tine hood flap and look for a plastic tie securing the lever in place. Cut and remove the tie.
2. Remove the oil level check plug (M, Figure 2-10) on the left-side of the transmission. (Due to dried paint on the plug threads, it may require some force to remove the plug the first time.) The gear oil level is correct if oil starts to flow out of the hole as the plug is removed. If so, securely reinstall the plug.

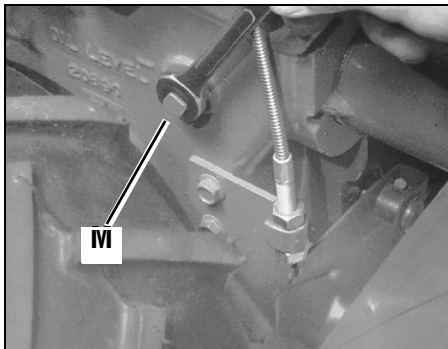

Figure 2-10: Gear oil level check plug.

3. If oil does not flow from the check hole, add oil as follows:

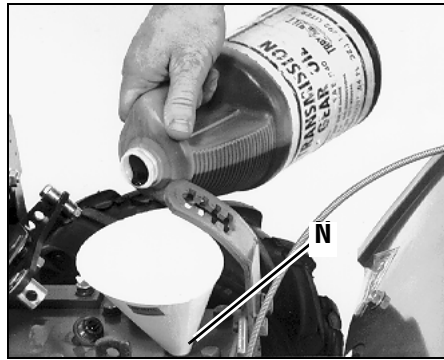

Figure 2-11: Adding gear oil.

**NOTE:** Do not use automatic transmission fluid or motor oil in the transmission.

- (a) Clean area around the fill hole (N, Figure 2-11) and unscrew gear oil fill plug.
- (b) If adding only a few ounces of gear oil, use API rated GL-4 or GL-5 gear oil having a viscosity of SAE 140, SAE 85W-140 or SAE 80W-90. If refilling an empty transmission, use only GL-4 gear oil having a viscosity of SAE 85W-140 or SAE 140.
- (c) Using a clean funnel, slowly add gear oil until it flows from the gear oil level check hole (N, Figure 2-11).
- (d) Reinstall and tighten securely the gear oil fill plug (M, Figure 2-10).

#### STEP 6: ATTACH WHEEL GEAR LEVER

1. Insert the Wheel Gear Lever (P, Figure 2-12) up through the slot in the control panel that is labeled "WHEEL GEAR."
2. Insert two #10-32 x 1/2" round head screws down through the "+" marks on the control panel decal and securely attach the wheel gear mounting bracket using two #10 lockwashers and #10-32 nuts.
3. Use a small board or rubber mallet to tap the Wheel Gear Lever knob securely onto the lever (R, Figure 2-13).
4. Secure the wheel gear cable and the reverse clutch control cable to the left-side handlebar with two plastic ties (S, Figure 2-13) located about two feet apart. Snip off any excess tie length with scissors.

#### STEP 7: CHECK AIR

Use a tire pressure gauge to check the air pressure in both tires. Deflate or inflate both tires equally to between 15 PSI and 20 PSI. Be sure that both tires are inflated equally or the unit will pull to one side.

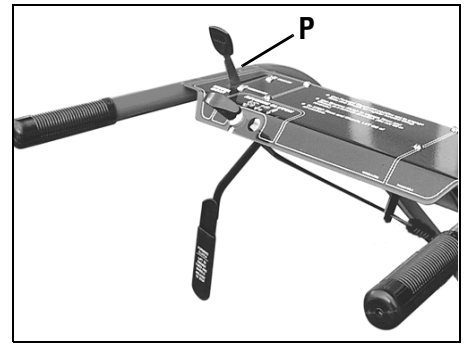

Figure 2-12: Attach Wheel Gear Lever.

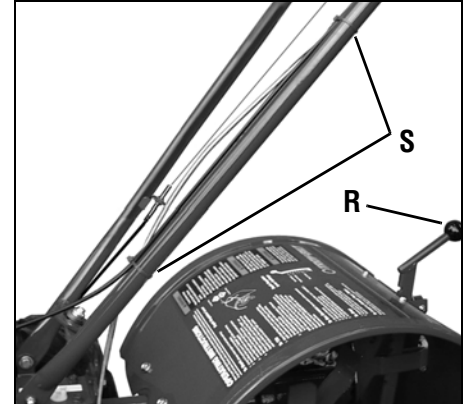

Figure 2-13: Attach wheel gear cable and reverse clutch cable with cable ties (S).

#### STEP 8: CHECK HARDWARE

Inspect the hardware on the unit and tighten any loose screws, bolts and nuts.



## SECTION 3: FEATURES AND CONTROLS



**WARNING:** Before operating your machine, carefully read and understand all safety, controls and operating instructions in this Manual, the separate Engine Owner's Manual, and on the decals on the machine. Failure to follow these instructions can result in serious personal injury.

### Tiller Features

This section describes the location and function of the controls on your tiller. Refer to Section 4: *Operation* for detailed operating instructions.

Practice using these controls, with the engine shut off, until you understand the operation of the controls and feel confident with each of them.

**IMPORTANT:** Refer to the separate engine manufacturer's Engine Owner's Manual for information about the controls on the engine.

### Wheel Gear Lever

This lever (A, Figure 3-1) has two positions: ENGAGE and DISENGAGE.

In the ENGAGE position, the wheels will start turning when either the Forward Clutch or the Reverse Clutch is engaged.

**NOTE:** *The tines will also start turning when either clutch is engaged.*



**DANGER:** Never place the Wheel Gear Lever in DISENGAGE (Freewheel) when the engine is running. Having the Wheel Gear Lever in engaging the tines/wheels with either the Forward Clutch or the Reverse Clutch could allow the tines to propel the tiller rapidly backward. Failure to follow this instruction could result in personal injury or property damage.

The DISENGAGE (freewheel) position places the wheels in freewheeling mode to allow the wheels to turn without starting the engine. Use the DISENGAGE position only when the engine is not running.

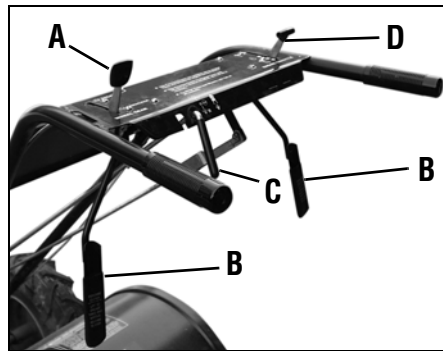

Figure 3-1: Control panel.

To shift to ENGAGE, gently (do not force) move the lever forward while rolling the tiller a few inches forward or backward. (Moving the tiller helps align the transmission shift mechanism). The wheels will not freewheel when the lever is properly set in the ENGAGE position.

To shift to DISENGAGE, move the lever rearward, without rolling the tiller. The wheels roll freely when the lever is properly set in the DISENGAGE position.

### Forward Clutch Levers

Two interconnected levers (B, Figure 3-1) control engagement of the forward drive to the wheels and power to the tines.



**WARNING:** Never engage wheels and tines with Forward Clutch or Reverse Clutch unless Wheel Gear Lever is in ENGAGE. Engaging the Forward Clutch or Reverse Clutch when wheels are not engaged could allow the tines to rapidly propel tiller backward. Failure to follow this warning could result in personal injury or property damage.

#### To Operate Forward Clutch:

1. Before engaging the Forward Clutch, put the Wheel Gear Lever into the ENGAGE position (see "WARNING" above).
2. Lift and hold one or both levers against the handlebar grips to engage the wheels and tines.
3. Release BOTH levers to disengage wheels and tines. All forward motion will stop (engine will continue to run).

**IMPORTANT:** The Forward Clutch Levers are connected to a mechanical interlock that automatically shifts a separate Wheel Gear Lever (A, Figure 3-1) into ENGAGE position when either Forward Clutch Lever is pulled up against the handlebars. This is a safety feature designed to prevent the wheels from being in DISENGAGE (freewheel) position when the tines are rotating.

Before starting the engine, test the function of the mechanical interlock as follows:

1. Put Wheel Gear Lever into DISENGAGE position and roll tiller back and forth a few inches. Wheels should roll freely.
2. Without rolling the tiller, squeeze either Forward Clutch Lever against the handlebar grips. As the levers move upward, the mechanical interlock automatically moves the Wheel Gear Lever forward into the ENGAGE position (roll tiller back and forth a few inches). If it does, the wheels will not roll freely when you push and pull on the handlebars.
3. The mechanical interlock works properly if it functions as described in Step 2. If the mechanical interlock does not function properly, do not operate the tiller until it has been corrected (see your authorized dealer or contact the factory).

### Reverse Clutch Control

This control (C, Figure 3-1) engages the reverse drive to the wheels and power to the tines. It is used for moving the tiller short distances in a reverse direction.

#### To Operate Reverse Clutch:



**WARNING:** Use extreme caution when reversing or pulling the machine towards you. Look behind to avoid obstacles. Never attempt to till in reverse. Failure to follow this warning could result in personal injury or property damage.

1. Before engaging the Reverse Clutch, put the Wheel Gear Lever into ENGAGE. (see "WARNING" at left).
2. Release the Forward Clutch Levers.

3. To move the tiller in reverse, first stop all forward motion. Lift up the handlebars until the tines clear the ground and pull the Reverse Clutch lever out.

The wheels will rotate in a reverse direction as long as the lever is held in REVERSE. To stop the wheels and tines, release the lever and it will return to NEUTRAL. **Never attempt to till while moving in reverse direction.**

### Depth Regulator Lever

This lever (E, Figure 3-2) controls the tilling depth of the tines. Pull the lever straight back and slide it up or down to engage the notched height settings.

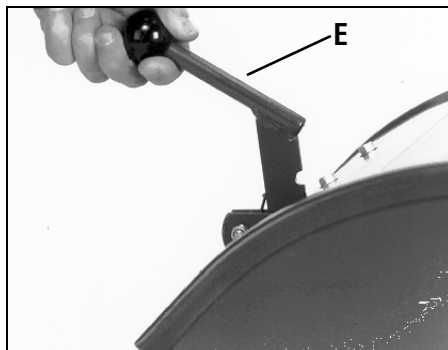

Figure 3-2: Depth Regulator Lever.

The highest notch (lever all the way down) raises the tines approximately 1-1/2 inches off the ground. This “travel” position allows the tiller to be moved without the tines digging into the ground.

Moving the lever up increases the tilling depth. The lowest notch allows a tilling depth of approximately six to eight inches, depending on soil conditions.

For best results, always begin tilling at a very shallow depth setting and gradually increase tilling depth.



**WARNING:** Place Depth Regulator Lever in “travel” position before starting engine. This position prevents the tines from touching the ground until you are ready to begin tilling. Do not attempt to till too deeply too quickly. Gradually work down to deeper tilling depths. Failure

to follow this warning could result in personal injury or property damage.

### Handlebar Height Adjustment

Handlebar height is adjustable to four different settings. When setting the height, keep in mind that the handlebars will be lower when the tines are engaged in the soil.



**WARNING:** Whenever the handlebar height is changed, the Forward Clutch shift mechanism must be readjusted. Before adjusting or checking the Forward Clutch mechanism, shut engine off, disconnect spark plug wire and prevent it from touching spark plug. Failure to follow this warning could cause the Forward Clutch mechanism to operate improperly which could result in personal injury or property damage.

#### To Adjust Handlebar Height:

1. Stop engine, wait for all parts to stop moving and then disconnect spark plug wire.
2. Loosen the two screws at lower ends of handlebar.
3. Loosen height adjustment screw (F, Figure 3-3) and pull keyed washer (G) free from slots in curved height adjustment bracket.

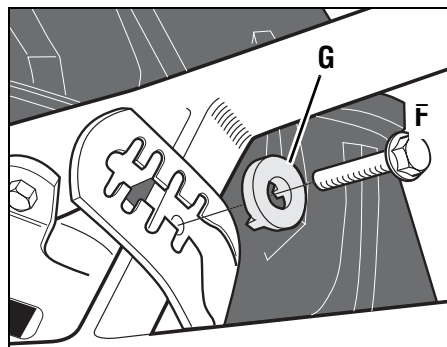

Figure 3-3: Handlebar height adjustment.

4. Move handlebars to a new slot setting and insert the raised key on the keyed washer into the slot. Tighten the height adjustment screw securely.
5. Retighten the two screws at ends of handlebar.

## Engine Controls

**IMPORTANT:** The engine is equipped with either a choke control or a primer bulb.

Refer to the Engine Owner's Manual (included in tiller literature package) to identify which device is on your engine.

### Recoil Starter

The recoil starter (H, Figure 3-4) is used to “pull-start” the engine. See *Engine Starting and Stopping* in Section 4 for detailed engine starting instructions.

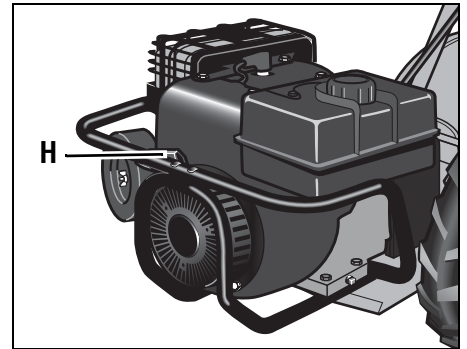

Figure 3-4: Recoil starter handle.

### Engine Throttle Lever

The throttle lever (D, Figure 3-1) is used to adjust engine speed as well as stop the engine. Use the START position when starting the engine. Pull the lever all way back to the STOP position to shut the engine off.

## SECTION 3: OPERATION



**WARNING:** Before operating your machine, carefully read and understand all safety (Section 1), controls (Section 3) and operating instructions (Section 4) in this Manual, in the separate Engine Owner's Manual, and on the decals on the machine. Failure to follow these instructions can result in serious personal injury.

### Introduction

Read this Section of the manual thoroughly before you start the engine. Then, take time to familiarize yourself with the basic operation of the tiller before using it. Find an open, level area and practice using the tiller controls without engaging the tines in the soil (put tines in "travel" setting). Only after you've become completely familiar with the tiller should you begin using it in the garden.

### Break-In Operation

Perform the following maintenance during the first hours of new operation (see Section 5: *Maintenance* and the maintenance section of the Engine Owner's Manual).

1. Change motor oil after first 2 hours of new engine operation.
2. Check for loose or missing hardware on unit. Tighten or replace as needed.
3. Check tension on forward drive belt after first 2 hours of operation.
4. Check transmission gear oil level after first 2 hours of operation.

### STARTING AND STOPPING ENGINE

The following steps describe how to start and stop the engine. **Do not engage the tines or wheels until you have read all of the operating instructions in this Section. Also review the safety rules in Section 1: Safety and the tiller and engine controls information in Section 3: Features and Controls.**

#### Pre-Start Checklist

Do the following before starting the engine.

1. Check unit for loose or missing hardware. Service as required.

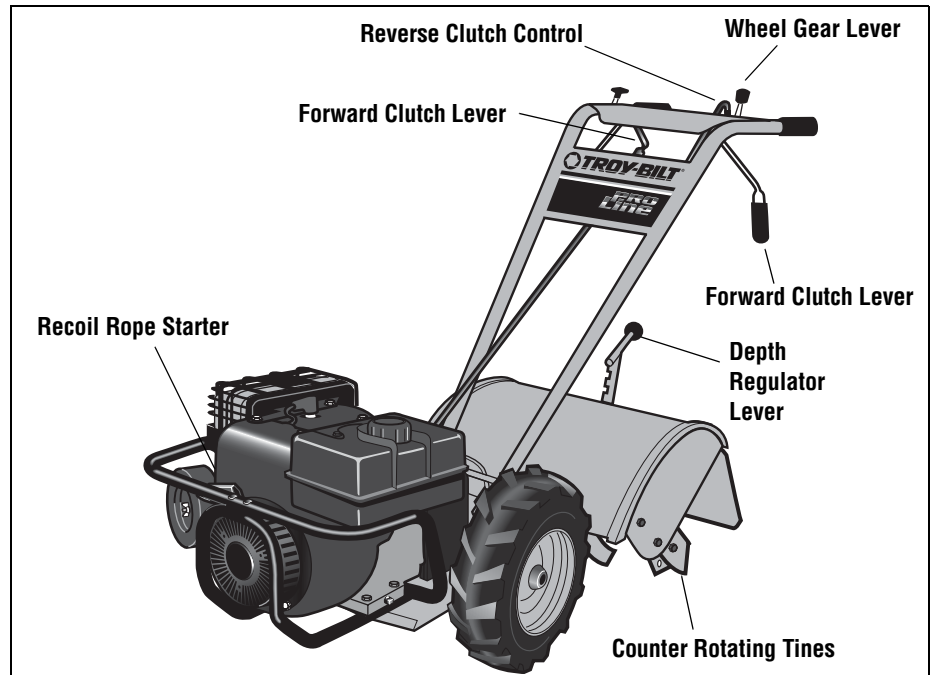

Figure 4-1

2. Check motor oil level. See Engine Owner's Manual.
3. Check that all safety guards and covers are in place.
4. Check air cleaner and engine cooling system. See Engine Owner's Manual.
5. Select a forward belt speed range (see *Changing Belt Speed Ranges* in this Section).
6. Fill the fuel tank with gasoline according to the directions in the separate Engine Owner's Manual. Follow all instructions and safety rules carefully.



**DANGER:** GASOLINE IS HIGHLY FLAMMABLE AND ITS VAPORS ARE EXPLOSIVE. Follow gasoline safety rules in this manual (see Section 1) and in the separate Engine Owner's Manual. Failure to follow gasoline safety instructions can result in serious personal injury and property damage.

7. Attach spark plug wire to spark plug.

#### Starting the Engine

1. Complete the *Pre-Start Checklist*.
2. Put the Wheel Gear Lever (Figure 4-1) into the ENGAGE position.



**CAUTION:** To help prevent serious personal injury or damage to equipment:

- Before starting engine, put Wheel Gear Lever into ENGAGE position.
  - Before starting engine, put Forward Clutch Levers and Reverse Clutch Control into neutral (disengaged) positions by releasing controls.
  - Never run engine indoors or in an enclosed, poorly ventilated area. Engine exhaust contains carbon monoxide, an odorless and deadly gas.
  - Avoid engine muffler and nearby areas. Temperatures in these areas may exceed 150° F.
3. Put the Depth Regulator Lever into the "travel" position (lever all the way down) so that the tines are clear of the ground.
  4. Release all controls on the tiller.
  5. If the engine is equipped with a fuel shutoff valve, turn the valve to the open position, as instructed in the separate Engine Owner's Manual.



**WARNING:** Keep away from rotating tines. Rotating tines will cause injury.

6. Move the Engine Throttle Lever into the START position.

7. Choke or prime the engine as instructed in the separate Engine Owner's Manual.
8. Check behind you to avoid contacting



any obstacles when pulling the starter rope. Place one hand on the fuel tank to stabilize the unit and use the recoil starter to start the engine as instructed in the Engine Owner's Manual. When the engine starts, gradually move the choke lever (on engines so equipped) to the NO CHOKE, CHOKE OFF or RUN position, whichever applies.

9. Use the FAST throttle speed setting when tilling.

### Stopping the Engine

1. To stop the wheels and tines, release the Forward Clutch levers or the Reverse Clutch Control (whichever control is in use).
2. To stop the engine, move the Engine Throttle Lever into the STOP position.

### Operating Tiller



**WARNING:** Before tilling, contact your telephone and utilities company to inquire if underground lines are on your property.

The following pages provide guidelines to using your tiller effectively and safely in various gardening applications. Be sure to read *Tilling Tips & Techniques* in this Section before you actually put the tines into the soil.

1. Follow the *Pre-Start Checklist* on the previous page. Be sure that the Wheel Gear Lever is in the ENGAGE position.
2. Move the Depth Regulator Lever into the "travel" position (lever all the way down) so that the tines clear the ground. Use this position when practicing with or transporting the tiller. When you are ready to begin tilling, move the Depth Regulator Lever into the desired depth setting (see *Tilling Tips & Techniques*).
3. Start the engine and allow it to warm up. When warm, move the throttle control into the FAST speed setting.

4. For forward motion of the wheels and power to the tines:

- (a) Pull up and hold the Forward Clutch levers against the handlebars. To stop the wheels and tines, release both levers.



**WARNING:** Do not push down on the handlebars to try to make the tiller till more deeply. This prevents the wheels from holding the tiller back and can allow the tines to rapidly propel the tiller backward toward the operator, which could result in loss of control, property damage, or personal injury.

- (b) As the tiller moves forward, relax and let the wheels pull the unit along while the tines dig. Walk behind and a little to one side of the tiller. Use a light but secure grip with one hand on the handlebars, but keep your arm loose. See Figure 4-2. Let the tiller move ahead at its own pace. Do not push down on the handlebars to try and force the tiller to dig deeper – this takes weight off the wheels, reduces traction, and causes the tines to try and propel the tiller.

5. For reverse motion of the wheels and tines:

- (a) Look behind and exercise caution when operating in reverse. **Do not till while in reverse.**
- (b) Stop all forward motion before reversing. Lift the handlebars with one hand until the tines are off the ground and then pull the Reverse Clutch control out (see Figure 4-3). To stop reverse motion, let go of the Reverse Clutch Control.

6. To turn the tiller around:

- (a) Practice turning in a level, open area. Be very careful to keep your feet and legs away from the tines.
- (b) To start a turn, reduce the engine speed and then lift the handlebars until the engine and tines are balanced over the wheels (Figure 4-4).
- (c) With the tiller balanced, push sideways on the handlebar to move the tiller in the direction of the turn (Figure 4-5). After completing the turn, slowly lower the tines into the soil and increase the engine speed.



**Figure 4-2:** Use one hand to guide tiller when moving forward.



**Figure 4-3:** Raise tines off ground and look behind when moving in reverse.



**Figure 4-4:** Find balance point before turning.



**Figure 4-5**

## Stopping the Tiller and Engine

1. To stop the wheels and tines, release the Forward Clutch levers or the Reverse Clutch Control (whichever is engaged).
2. To stop the engine, move the Engine Throttle Lever to STOP.
3. If the engine is equipped with a fuel shut-off valve, close the valve as instructed in the Engine Owner's Manual.



**WARNING:** Before changing belt speeds, stop engine, wait for all parts to stop moving, let engine cool and disconnect spark plug wire. Failure to follow these instructions could result in personal injury.

## Changing Belt Range Speeds

The tiller has two forward belt range speeds for the wheels and tines: Low and High. The two ranges are obtained by moving the forward drive belt between two sets of grooves on the forward drive pulley and the transmission drive pulley.

**NOTE:** The High speed belt range is recommended for all tilling purposes. The Low speed belt range will operate the tines and wheels at a slower forward speed, which may be suitable in some conditions (such as tilling in very hard ground).

### To Change from Low to High Speed:

1. Stop the engine, allow it to cool, and disconnect the spark plug wire.
2. Move the Wheel Gear Lever into the DIS-ENGAGE position.
3. Remove the two nuts from the plastic belt cover on top of the transmission and remove the belt cover.
4. From beneath the tiller, move the forward drive belt out of the transmission low speed groove (B, Figure 4-10) and into the high speed groove (D).
5. Pull upward on the belt to remove any slack and slip the belt out of the engine drive pulley low speed groove (A, Figure 4-10) and into the high speed groove (C).

**NOTE:** If the belt is difficult to move, pull on the engine start rope while pushing the belt with your finger (engine drive pulley will turn as start rope is pulled).

6. Check that the belt is within the forward belt guide (E, Figures 4-10 and 4-11) on the right-side of the unit and is within the forward idler (F, Figure 4-11) on the left-side. Be sure that the belt is situated in the center grooves (C and D, Figure 4-10) of the engine (upper) and transmission (lower) pulleys.

7. Reinstall the plastic belt cover and secure it with the two nuts.

8. Put Wheel Gear Lever in ENGAGE and reconnect spark plug wire before attempting to start the engine.

### To Change from High to Low Speed:

1. Stop the engine, allow it to cool, and disconnect the spark plug wire.
2. Put Wheel Gear Lever in DISENGAGE.
3. Remove the two nuts from the plastic belt cover on top of the transmission and remove the belt cover.
4. From beneath the tiller, move the forward drive belt out of the transmission pulley high speed groove (D, Figure 4-10) and into the low speed groove (B).

5. Pull upward on the belt to remove any slack and slip the belt out of the engine drive pulley high speed groove (C, Figure 4-10) and into the low speed groove (A).

**NOTE:** If the belt is difficult to move, pull on the engine start rope while pushing the belt with your finger (engine drive pulley will turn as start rope is pulled).

6. Check that the belt is within the forward belt guide (E, Figures 4-10 and 4-11) on the right-side of the unit and is within the forward idler (F, Figure 4-11) on the left-side. Be sure that the belt is situated in the rear grooves (A and B, Figure 4-10) of the engine (upper) and transmission (lower) pulleys.

7. Reinstall the plastic belt cover and secure it with the two nuts.

8. Put the Wheel Gear Lever in ENGAGE and reconnect the spark plug wire before attempting to start the engine.

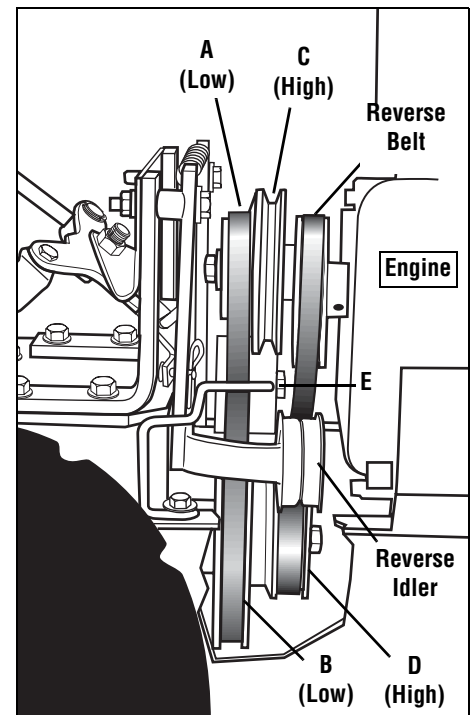

**Figure 4-10:** Right-side view of engine and transmission pulleys (engine is at right-side of view).

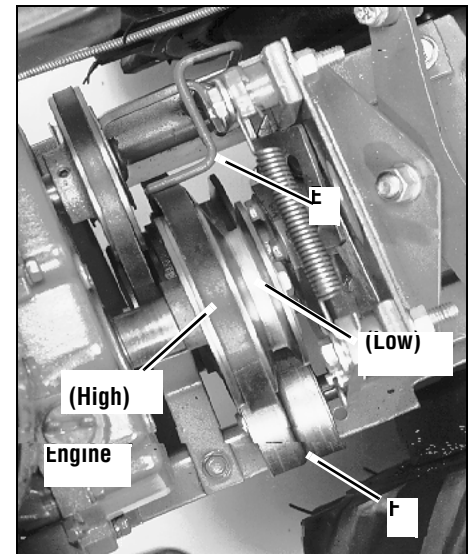

**Figure 4-11:** Top view of forward drive pulley system (engine is at left-side of view).



## TILLING TIPS & TECHNIQUES (CON'T)

### Tilling On Slopes

#### Read the following recommendations before tilling on slopes:

If you must garden on a moderate slope, please follow two very important guidelines:

1. Till only on moderate slopes, never on steep ground where footing is difficult (review safety rules in Section 1: *Safety* of this manual).
2. We recommend tilling up and down slopes rather than terracing. Tilling vertically on a slope allows maximum planting area and also leaves room for cultivating.

**IMPORTANT:** When tilling on slopes, be sure the correct oil level is maintained in the engine (check every one-half hour of operation). The incline of the slope will cause the oil to slant away from its normal level and this can starve engine parts of required lubrication. Keep the motor oil level at the full point at all times!

#### Tilling Up and Down Slopes (Vertical Tilling)

- To keep soil erosion to a minimum, be sure to add enough organic matter to the soil so that it has good moisture-holding texture and try to avoid leaving footprints or wheel marks.
- When tilling vertically, try to make the first pass uphill as the tiller digs more deeply going uphill than it does downhill. In soft soil or weeds, you may have to lift the handlebars slightly while going uphill. When going downhill, overlap the first pass by about one-half the width of the tiller.



**WARNING:** Do not operate tiller on a slope too steep for safe operation. Till slowly and be sure you have good footing. Never permit tiller to freewheel down slopes. Failure to follow this warning could result in personal injury.

### Clearing the Tines

The tines have a self-clearing action which eliminates most tangling of debris in the tines. However, occasionally dry grass, stringy stalks or tough vines may become tangled. Follow these procedures to help avoid tangling and to clean the tines, if necessary.

- To reduce tangling, set the depth regulator deep enough to get maximum “chopping” action as the tines chop the material against the ground. Also, try to till under crop residues or cover crops while they are green, moist and tender.
- While tilling, try swaying the handlebars from side to side (about 6" to 12"). This “fishtailing” action often clears the tines of debris.
- If tangling occurs, lift the tines out of the soil and run the tiller in reverse (if unit is equipped with powered reverse) for a few feet. This reversing action should unwind a good deal of debris.

- It may be necessary to remove the debris by hand (a pocket knife will help you to cut away the material). Be sure to stop the engine and disconnect the spark plug wire before clearing the tines by hand.



**WARNING:** Before clearing the tines by hand, stop the engine, allow all moving parts to stop and disconnect the spark plug wire. Remove the ignition key on electric start models. Failure to follow this warning could result in personal injury.

### Loading and Unloading the Tiller



**WARNING:** Loading and unloading the tiller into a vehicle is potentially hazardous and we don't recommend doing so unless absolutely necessary, as this could result in personal injury or property damage. However, if you must load or unload the tiller, follow the guidelines given next.

- Before loading or unloading, stop the engine, wait for all parts to stop moving, disconnect the spark plug wire and let the engine and muffler cool.
- The tiller is too heavy and bulky to lift safely by one person. Two or more people should share the load.

- Use sturdy ramps and manually (engine shut off) roll the tiller into and out of the vehicle. Two or more people are needed to do this.
- The ramps must be strong enough to support the combined weight of the tiller and any handlers. The ramps should provide good traction to prevent slipping; they should have side rails to guide the tiller along the ramps; and they should have a locking device to secure them to the vehicle.
- The handlers should wear sturdy footwear that will help to prevent slipping.
- Position the loading vehicle so that the ramp angle is as flat as possible (the less incline to the ramp, the better). Turn the vehicle's engine off and apply its parking brake.

- When going up ramps, stand in the normal operating position and push the tiller ahead of you. Have a person at each side to turn the wheels.
- When going down ramps, walk backward with the tiller following you. Keep alert for any obstacles behind you. Position a person at each wheel to control the speed of the tiller. Never go down ramps tiller-first, as the tiller could tip forward.
- Place wooden blocks on the downhill side of the wheels if you need to stop the tiller from rolling down the ramp. Also, use the blocks to temporarily keep the tiller in place on the ramps (if necessary), and to chock the wheels in place after the tiller is in the vehicle.
- After loading the tiller, prevent it from rolling by engaging the wheels in the WHEEL DRIVE position. Chock the wheels with blocks and securely tie the tiller down.

## SECTION 5: MAINTENANCE



**WARNING:** Before inspecting, cleaning or servicing the machine, shut off engine, wait for all moving parts to come to a complete stop, disconnect spark plug wire and move wire away from spark plug. Remove ignition key on electric start models. Failure to follow these instructions can result in serious personal injury or property damage.

### MAINTENANCE SCHEDULE

PROCEDURE	NOTES
Check motor oil level	2, 3
Clean engine	2, 7
Check drive belt tension	1, 4
Check nuts and bolts	1, 4
Change motor oil	1, 4, 6
Lubricate tiller	4
Service foam pre-cleaner air filter	7
Service paper air filter	7
Check gear oil level in transmission	1, 5
Check tines for wear	5
Check air pressure in tires	5
Service spark plug	7

#### NOTES

- 1 – After first 2 hours of break-in operation.
- 2 – Before each use.
- 3 – Every 5 operating hours.
- 4 – Every 10 operating hours.
- 5 – Every 30 operating hours.
- 6 – Change more frequently in dusty or dirty conditions.
- 7 – See Engine Owner's Manual for service recommendations.
- 8 – Whichever time interval occurs first.

#### Tiller Lubrication

Proper lubrication of the tiller is an essential part of your maintenance program. After every 10 operating hours, oil or grease the lubrication points shown in Figures 5-1 and 5-2 and described below.

Use general purpose lubricating oil (#30 weight motor oil is suitable) and a general purpose grease (metal lubricant is preferred, if available).

- Remove wheels and clean wheel shaft (A, Figure 5-1). Apply a thin coating of grease to shaft before reinstalling wheels.
- Grease back, front and sides of depth regulator lever (B, Figure 5-1).

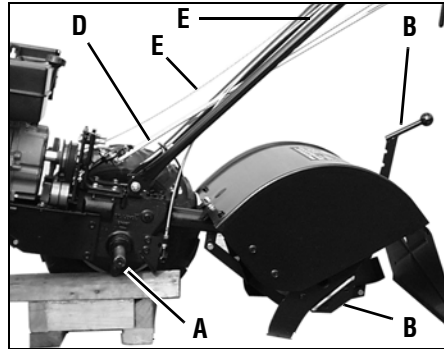

Figure 5-1

- Remove tines and clean tine shafts (C, Figure 5-1). Inspect for rust, rough spots or burrs (especially around holes). File or sand smooth and coat ends of shaft with grease.
- Oil the threads on the handlebar height adjustment handle (D, Figure 5-1).
- Oil the outer casings of the engine throttle cable and the wheel gear cable (E, Figure 5-1). Allow oil to soak in and then wipe off any excess.
- Oil the various pivot points (F, Figure 5-2) on the shifting mechanism, the handlebar, and the idler arms (do not allow oil on the belts or pulleys).

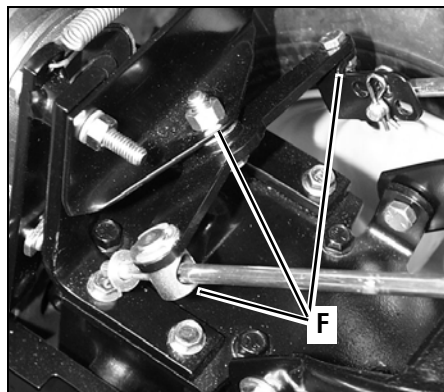

Figure 5-2

#### Check Tire Air Pressure

Check the air pressure in both tires. Deflate or inflate both tires evenly to between 15 and 20 PSI (pounds per square inch). Be sure that both tires have equal air pressure or the unit will pull to one side.

#### Check For Oil Leaks

Before each use, check your tiller for signs of an oil leak—usually a dirty, oily accumu-

lation either on the unit or on the floor where it has been parked.

A little seepage around a cover or oil seal is usually not a cause for alarm. However, if the oil drips overnight, then immediate attention is needed—ignoring a leak can result in severe transmission damage.

If a cover leaks, try tightening any loose screws or bolts. If the fasteners are tight, a new gasket or oil seal may be required. If the leak is from around a shaft and oil seal, the oil seal probably needs to be replaced. See your authorized dealer or contact the factory for service or advice.

**IMPORTANT:** Never operate the tiller if the transmission is low on oil. Check the oil level after every 30 hours of operation and whenever there is any oil leakage.

#### Check Hardware

Check the unit for loose or missing hardware after every 10 operating hours. Loose or missing hardware can lead to equipment failure, poor performance, or oil leaks.

Be sure to check the three end cap mounting screws located at the rear of the transmission (Figure 5-3). Lift the tine flap to service those screws.

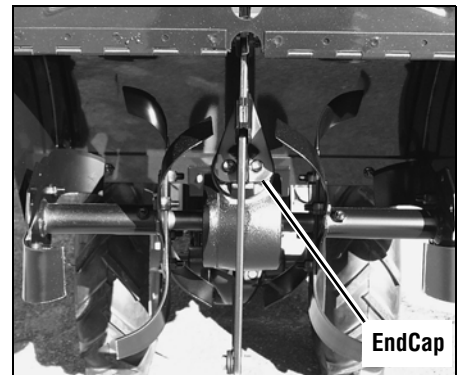
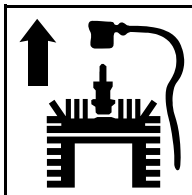

Figure 5-3

#### Transmission Gear Oil Service

Check the transmission gear oil level after every 30 hours of operation or whenever you notice any oil leak. Operating the tiller when the transmission is low on oil can result in severe damage.





**WARNING:** Before inspecting, cleaning or servicing the machine, shut off engine, wait for all moving parts to come to a complete stop, disconnect spark plug wire and move wire away from spark plug. Failure to follow these instructions can result in serious personal injury or property damage.

#### A. To Check Transmission

1. Check the gear oil level when the transmission is cool. Gear oil expands in warm operating temperatures and will result in an incorrect oil level reading.
2. To check the gear oil level (and to add oil, if necessary), refer to *STEP 5: Check Gear Oil Level in Transmission* in Section 2 of this manual.

#### B. To Drain and Refill the Transmission:

The transmission gear oil does not need to be changed unless it has been contaminated with dirt, sand or metal particles.

1. Prop up the left side of the unit securely. Remove the left-side wheel by removing the wheel mounting hardware.
2. Unscrew the plastic gear oil fill plug from the top of the transmission
3. Place a clean pan below the transmission drain plug (Figure 5-4) and remove the drain plug. The oil will start flowing out of the drain hole (it may flow slowly, especially in cold temperatures).

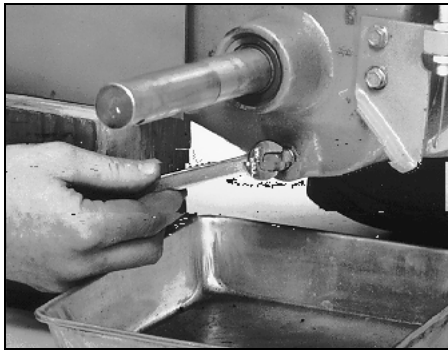

**Figure 5-4: Remove drain plug to drain transmission gear oil (also remove oil fill plug and oil level check plug).**

4. Remove the transmission gear oil level check plug that is located a few inches above the left-side wheel shaft (N, Figure 2-11).
5. When the oil stops flowing, tilt the transmission forward to drain oil from the rear of the transmission.
6. After draining the oil, clean the threads of the drain plug, apply a non-hardening, removable gasket sealant to the threads, and securely reinstall the drain plug.

7. Use a clean funnel to slowly add SAE 140 or SAE 85W-140 weight gear oil (with an API rating of GL-4 only) to the transmission. The transmission holds approximately 3-1/4 pints (52-54 ounces). Tilt the tiller slightly backwards to make sure the gear oil reaches the rear (tine) end of the transmission. Stop adding gear oil when it begins to flow from the oil level check hole on the side of the ion.

8. Securely reinstall the oil level check plug.
9. Securely reinstall the gear oil fill plug on top of the transmission.
10. Reinstall the wheel and remove the prop.

#### Engine Oil Service

Check the motor oil level before starting the engine each day and after each 5 hours of continuous operation. Running the engine when the oil level is low will quickly ruin the engine.

It is recommended that you change the motor oil after every 10 hours of operation and even sooner when operating in extremely dirty or dusty conditions.

#### A. To Check the Motor Oil Level:

1. Move the tiller to a level area and stop the engine.
2. Level the engine by moving the Depth Regulator Lever into the second notch from the top.
3. Clean the area around the oil dipstick or oil fill tube (whichever applies) to prevent dirt from falling into the crankcase.
4. On engines with an oil fill tube, remove the filler cap and add oil (if required) until it reaches the top of the tube. Reinstall the filler cap.
5. On engines with a dipstick, remove it, wipe it clean, and reinstall it finger-tight. Remove the dipstick again and check the reading. Add oil (if required) to bring the level to the FULL mark. Do not overfill.

#### B. To Change the Motor Oil:

Change the motor oil as instructed in the separate Engine Owner's Manual.

#### Air Cleaner Service

The engine air cleaner filters dirt and dust out of the air before it enters the carburetor. Operating the engine with a dirty, clogged air filter can cause poor performance and damage to the engine. Never operate the engine without the air cleaner installed. Inspect and service the air cleaner more often if operating in very dusty or dirty conditions.

Service the air cleaner as instructed in the separate Engine Owner's Manual.

#### Spark Plug Service

Inspect and clean or replace the spark plug after every 100 operating hours or annually. Clean the plug and set the gap as described in the separate Engine Owner's Manual.

In some areas, local law requires using resistor spark plugs to suppress ignition signals. If the engine was originally equipped with a resistor spark plug, use the same type for replacement.

#### Spark Arrester Screen Service

If the engine muffler is equipped with a spark arrester screen, remove and clean it according to the time intervals and instructions in the separate Engine Owner's Manual.

#### Engine Cleaning

The engine must be kept clean to assure smooth operation and to prevent damage from overheating. Refer to the separate Engine Owner's Manual for specific repair and cleaning instructions. All inspections and services must be done with the engine shut off and cool to the touch.

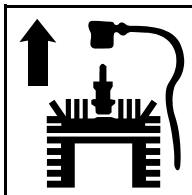

**WARNING:** Before inspecting, cleaning or servicing the machine, shut off engine, wait for all moving parts to come to a complete stop, disconnect spark plug wire and move wire away from spark plug. Failure to follow these instructions can result in serious personal injury or property damage.

## Carburetor / Governor Adjustment



**WARNING:** Operators shall not tamper with the engine governor settings; the governor controls the maximum safe operating speed to protect the engine and all moving parts from damage caused by overspeed. Authorized service shall be sought if a problem exists.

The carburetor was adjusted at the factory for best operating speed. Refer to the separate Engine Owner's Manual for any adjustment information or see your authorized engine service dealer.

The governor controls the maximum safe operating speed and protects the engine and all moving parts from damage caused by overspeeding. Do not tamper with the engine governor settings. Seek authorized service if a problem exists.

## Throttle Control Adjustment

If the engine does not respond to various throttle lever settings, refer to the separate Engine Owner's Manual for service information or contact your local authorized engine service dealer.

## Wheel Gear Cable Adjustment

When the Wheel Gear Lever is in DISENGAGE, the wheels will roll freely (free-wheel). The wheels should not roll freely when the lever is in ENGAGE. If the wheels roll freely when the Wheel Gear Lever is in ENGAGE, the wheel gear cable needs to be adjusted as described below.

1. With the engine shut off and the spark plug wire disconnected, put the Wheel Gear Lever in ENGAGE.
2. Loosen the top adjustment nut the wheel gear cable bracket located on the left side rear of the transmission.
3. Push wheel gear cable (B) down and roll tiller slightly forward or backward until eccentric lever (C) engages (locks) wheels.

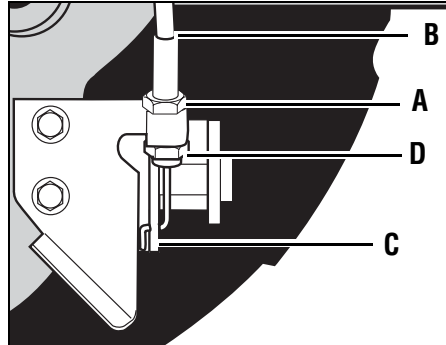

**Figure 5-5: Wheel gear cable assembly.**

Hold cable in that position and tighten top (A) and bottom (D) adjustment nuts.

4. Move Wheel Gear Lever to ENGAGE and DISENGAGE several times to check adjustment. The wheels should not roll when the lever is in ENGAGE, but they should roll when the lever is in DISENGAGE. Readjust the cable as required.

## Off Season Storage

When the tiller won't be used for extended periods, prepare it for storage as follows:

1. Clean the tiller and engine.
2. Do routine tiller lubrication (see *Tiller Lubrication*) and check for loose parts and hardware (see *Check Hardware*).
3. Protect the engine by performing the engine storage instructions in the separate Engine Owner's Manual.

**NOTE:** Be sure to protect the fuel lines, carburetor and fuel tank from gum deposits by removing fuel or by treating fuel with a fuel stabilizer (follow engine manufacturer's recommendations).

4. Store unit in a clean, dry area.
5. Never store the tiller with fuel in the fuel tank in an enclosed area where gas fumes could reach an open flame or spark, or where ignition sources are present (space heaters, hot water heaters, furnaces, etc.).

## Tines

The tines will wear with use and should be inspected at the beginning of each tilling season and after every 30 operating hours.

Tines can be replaced individually or as a complete set. Never inspect or service the tines unless the engine is stopped and the spark plug wire is disconnected.

**NOTE:** The tiller hood must be removed to take off either a single tine holder or individual tines. The hood is secured to the transmission housing with two rear bolts and two front bolts.

## Tine Inspection

With use, the tines (Figure 5-6) will become shorter, narrower and pointed. Badly worn tines will result in a loss of tilling depth and reduced effectiveness when chopping up and turning under organic matter.

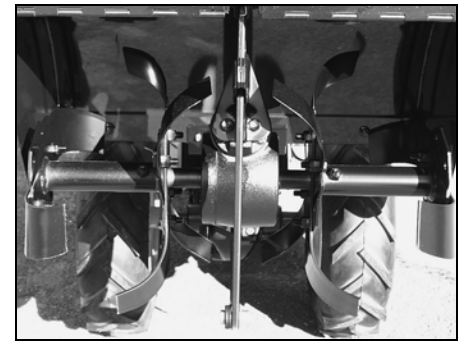
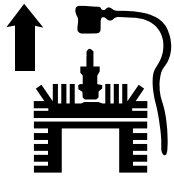

**Figure 5-6: Four tine gangs: two per side.**

## Removing and Installing

1. Use a 9/16" socket, 6" extension, a ratchet, and a 9/16" box wrench to loosen the nut (A, Figure 5-7) and bolt (B) that secure the tine holder to the tine shaft.
2. Use a rubber mallet to tap the tine holder loose.
3. Slide the tine assembly off the tine shaft.
4. Repeat Steps 1-through-3 above to remove the other tine assembly.
5. Installing the tine assembly is simply the reverse of its removal. Be sure the cutting edges face so they will enter the soil first when the tiller is moving forward—**this means the cutting edges face toward the operator position.**

First be sure to remove any rust, uneven spots or burrs from the tine shaft, using fine sandpaper. Then grease the tine shaft



**WARNING:** Before inspecting, cleaning or servicing the machine, shut off engine, wait for all moving parts to come to a complete stop, disconnect spark plug wire and move wire away from spark plug. Failure to follow these instructions can result in serious personal injury or property damage.

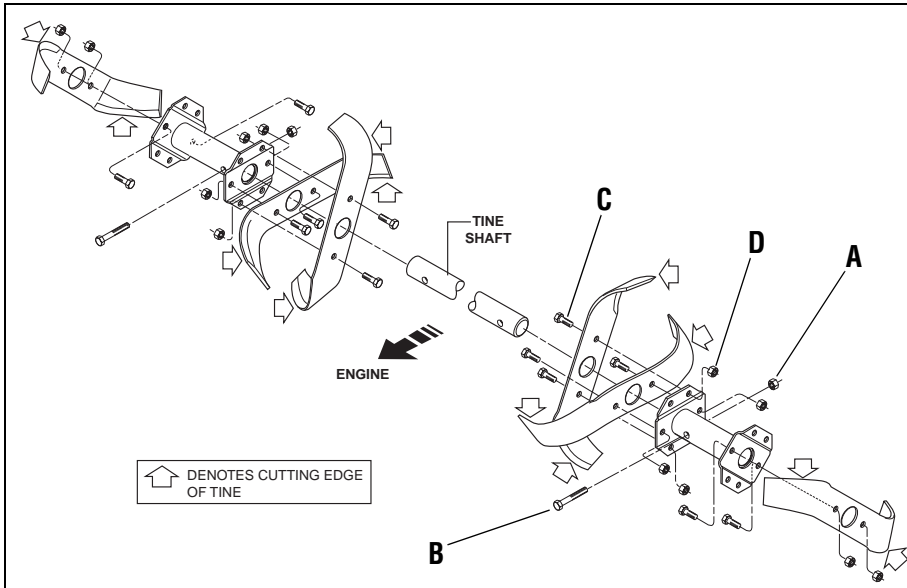

Figure 5-7: Complete tine assemblies— holders, tines and hardware.



**WARNING:** This is a CRT (counter-rotating tine) tiller and its tines must be mounted in the direction shown in Figure 5-7. Failure to comply could result in personal injury or property damage.

2. When installing individual tines, install them in the reverse order from which they were removed. The two sets of inboard tines are installed so one tine faces toward the transmission housing and the other tine faces away from it. The single outboard tine on each side faces toward the transmission housing. Also be sure the cutting edges face so they will enter the soil first when the tiller is moving forward—**this means the cutting edges face toward the operator position.**

### Checking And Adjusting Tension On Drive Belts

While checking belt tension, also check for cracks, cuts or frayed edges. A belt that is in poor condition should be replaced.



**WARNING:** Follow the belt adjustment instructions carefully. An incorrect adjustment could result in the Forward Clutch mechanism engaging too soon. This could cause loss of tiller control and result in personal injury or property damage.

Maintaining correct tension on the drive belts is important to good tilling performance and long belt life. A loose belt will slip on the engine and transmission pulleys and cause the tines and wheels to slow down – or stop completely – even though the engine is running at full speed. A loose belt will also result in premature wear to the belt.

The tension on a new forward drive belt should be checked after the first two (2) hours of operation. Thereafter, check the tension after every ten (10) hours of operation.

The reverse drive belt, because it is used infrequently, will not require an initial tension adjustment until a significant number of operating hours has passed.

### To Check and Adjust Tension on the Forward Drive Belt:

1. Checking for correct belt tension is the same as that described in item 5, *Step 4: Attach Forward Clutch Rod*. Before checking, shut off the engine, disconnect the spark plug wire, and allow the engine and muffler to cool down. If, after following the adjustment procedures, you cannot get the correct gap on the forward clutch rod adjustment bracket, you will need to make a secondary adjustment as described next.

2. Disconnect the Forward Clutch Rod (A, Figure 5-9) from the swivel plate (B) by removing the innermost hairpin cotter (C).

3. Unthread the Forward Clutch Rod (in a counterclockwise direction as viewed from the front of the unit) until one or two threads on the rod extend above the rectangular nut (D, Figure 5-10) on the forward clutch bracket.

4. Remove the belt cover.

5. Slip the forward drive belt (E, Figure 5-10) off the engine-driven forward drive pulley by pushing it off (away from engine) with your left hand while pulling engine starter rope with your right hand.

6. On the **left** side of the unit (from operator's position) remove the hairpin cotter from the clevis pin (F, Figure 5-11) that connects the forward idler arm (G) to the forward adjustable link (H). Push inward on the forward idler arm (G) and remove the clevis pin (F).

7. There are two holes in the forward adjustable link (H, Figure 5-11). Push inward on the forward idler arm (G) and install the clevis pin (F) through the **inner** hole in the forward adjustable link (H) and out through the single hole in the forward idler arm (G). Secure the clevis pin with the hairpin cotter.

**NOTE:** *While pushing inward on the forward idler arm, be sure that the forward drive belt is moved off to the right side of the tiller. This creates more room to install the clevis pin when the forward idler arm is pushed inward.*

**IMPORTANT:** When the clevis pin is installed in the inner hole of the forward adjustable link, the number of additional belt tension adjustments are limited. If, with future tension adjustments, you find that you cannot screw the forward clutch rod any farther into the rectangular nut on the forward clutch bracket, it means that the forward drive belt must be replaced. Before doing so, the clevis pin must be returned to the OUTSIDE hole in the forward adjustable link.

**8.** Replace the forward drive belt in the High speed groove (groove closest to engine) or the Low speed groove (rearmost) groove of the engine drive pulley and in the matching groove of the transmission pulley. Be sure the belt is to the inside of the wire formed belt guide (I, Figure 5-12) and to the inside of the forward drive idler pulley (J).

**To Check and Adjust Tension on the Reverse Drive Belt:**

- 1.** Remove the belt cover after first shutting off the engine, disconnecting the spark plug wire, and allowing the engine and muffler to cool down.
- 2.** Stand at the front of the tiller and use your left hand to push the reverse idler arm (K, Figure 5-13) inward as far as possible (the reverse idler pulley [L] is attached to the reverse idler arm).

Hold(rear -1.50-ow

**9.** Reinstall the belt cover and secure it with the two nuts.

**10.** Readjust the forward drive belt tension by following the instructions in Section 3: *Handlebar Height Adjustment.*

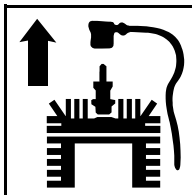

**WARNING:** Before inspecting, cleaning or servicing the machine, shut off engine, wait for all moving parts to come to a complete stop, disconnect spark plug wire and move wire away from spark plug. Failure to follow these instructions can result in serious personal injury or property damage.

front of the unit (not the operator's position). If the belt tension is correct, reinstall the belt cover and secure it with the two nuts.

- If the guide mark is aligned with the guide pin, or moves to the right side of the guide pin, then the belt is too loose and the tension must be readjusted as described next.

3. The reverse idler pulley (L, Figure 5-13) regulates the tension that is applied to the reverse drive belt (P). The following adjustment will allow the reverse idler pulley to apply more tension to a loose belt.

4. Remove the belt cover.

5. Slip the reverse belt (P, Figure 5-13) off the engine-driven reverse (upper) pulley.

6. On the **right** side of the unit (as viewed from operator's position), remove the hair-pin cotter from the clevis pin (R, Figure 5-13) that connects the reverse idler arm (K) to the reverse adjustable link. Push inward on the reverse idler arm (K) and remove the clevis pin (R).

7. There are two holes in the reverse adjustable link (S, Figure 5-15). Push inward on the reverse idler arm (K) and install the clevis pin (R) through the **inner** hole in the reverse adjustable link (S) and out through the single hole in the reverse idler arm (K). Secure the clevis pin with the hairpin cotter.

8. Reinstall the reverse belt (P, Figure 5-13) on the reverse (upper) pulley, making sure

the belt is located to the inside of the reverse idler pulley (L, Figure 5-13).

9. Reinstall the belt cover and secure it with the two nuts.

**IMPORTANT:** If, in future tests for reverse belt tension, the guide mark should again align with or move to the right side of the guide pin, it means that the reverse belt is worn beyond adjustment. Before installing a new belt, you must return the clevis pin to the **OUTSIDE** hole in the reverse adjustable link.

### Forward Drive Belt Removal and Installation

This model has two forward speeds (High

belt range; the rearmost groove is for the Low speed forward belt range.

#### A. Removing the Forward Drive Belt:

1. Stop the engine, allow it to cool and disconnect the spark plug wire before working near the belts.

2. Remove the reverse drive belt following the *Removing the Reverse Drive Belt* instructions in this section.

3. Move the forward drive belt (B, Figure 5-16) completely off the engine forward drive pulley (D).

4. Slip the forward drive belt completely off the transmission drive pulley (C, Figure 5-16) by moving it to the front of the pulley.

5. Pull the forward drive belt up and off the pulleys by feeding the bottom half of the belt in between the engine and transmission pulleys.

#### B. Installing the Forward Drive Belt:

1. The reverse drive belt must be removed before installing the forward drive belt.

2. Slip the forward drive belt down between the rear of the engine forward drive pulley (D, Figure 5-16) and feed the bottom half in between the engine and transmission pulleys (see Figure 5-17). Be sure that the belt is to the inside of the forward idler pulley and forward belt guide (see J and I, Figure 5-12).

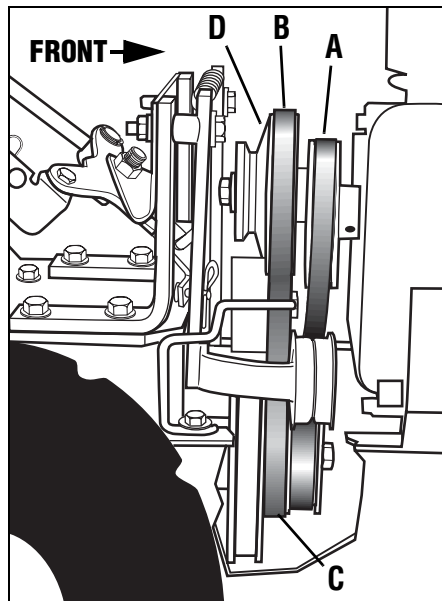

Figure 5-16: Belt drive system.

and Low) and one reverse speed. The forward engine pulley (D, Figure 5-16) has two grooves for the two forward speeds. The reverse engine pulley (A, Figure 5-16) has one groove for the one reverse speed. The transmission pulley (C, Figure 5-16) has three grooves. The groove closest to the engine is for the reverse belt. The middle groove is for the High speed forward

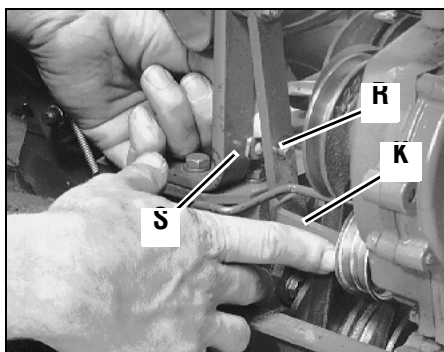

Figure 5-15: Installing clevis pin in inside hole of reverse adjustable link.

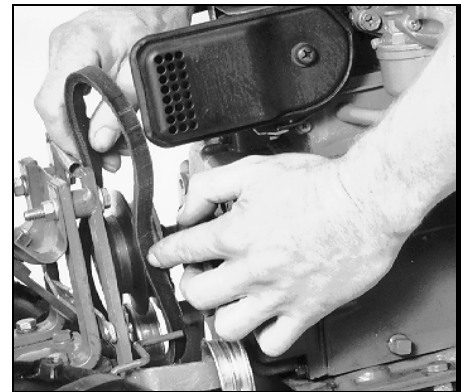
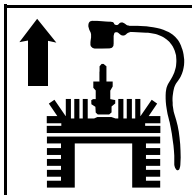

Figure 5-17: Install forward drive belt over rear of engine forward pulley and bring lower half of belt down and in front of transmission pulley.



**WARNING:** Before inspecting, cleaning or servicing the machine, shut off engine, wait for all moving parts to come to a complete stop, disconnect spark plug wire and move wire away from spark plug. Failure to follow these instructions can result in serious personal injury or property damage.

3. Slip the forward drive belt down and over the front of the transmission pulley (C, Figure 5-16). NOTE: For additional working room, loosen the reverse belt guide (V, Figure 5-12) and twist it out of the way.
4. Put the lower half of the belt into the High speed groove (middle groove) or the Low speed groove (rear-most groove) of the transmission pulley (C, Figure 5-16).
5. Put the upper half of the belt in the High speed groove (groove closest to engine) or the Low speed groove (rear-most groove) of the engine forward drive pulley (D, Figure 5-16).

**IMPORTANT:** Make sure that the forward drive belt is to the inside of the wire belt guide (I, Figure 5-12) and the forward idler pulley (J).

6. If you loosened the belt guide, wait until the reverse drive belt is installed before securing the belt guide.
7. Install the reverse drive belt.
8. Install the belt cover and secure it with the two nuts.
9. If you installed a new belt, check the tension after two hours of operation.

### Reverse Drive Belt Removal and Installation

NOTE: The forward drive belt must be installed before installing the reverse drive belt.

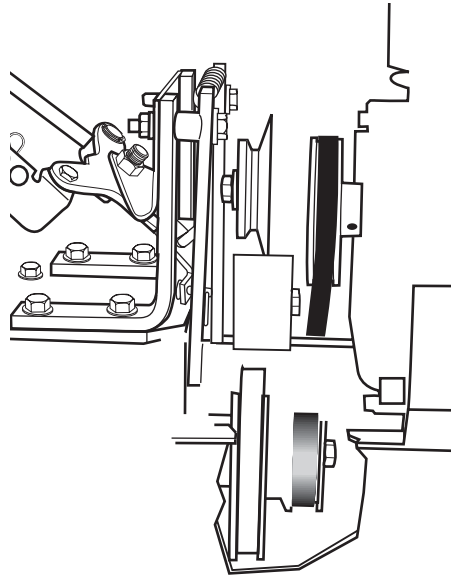

**Figure 5-18: Removing and installing reverse belt.**

#### A. Removing the Reverse Drive Belt:

1. Stop the engine and allow it to cool before working near the belts. Be sure the spark plug wire is disconnected and on electric start models the ignition key is removed.
2. Remove the belt cover by removing the two nuts. For easier access to the transmission (lower) pulley, remove the transmission cover located below the transmission pulley.

3. Slip the reverse belt off the engine reverse pulley (A, Figure 5-18). If necessary, work the belt off the pulley with your left hand while pulling the engine recoil starter rope with your right hand.
4. Push the upper half of the reverse belt downward to create slack in the belt. Then reach underneath the transmission and slip the belt off the front of the transmission pulley (B, Figure 5-18).
5. Pull the belt up and past the engine reverse pulley (A, Figure 5-18).

#### B. Installing the Reverse Drive Belt:

1. Slip the reverse belt down between the engine reverse pulley (A, Figure 5-18) and the engine forward drive pulley (C).
2. Loop the bottom half of the belt over the front of the transmission pulley (B, Figure 5-18) and seat the belt in the front groove of the pulley.
3. Place the belt to the inside of the reverse idler pulley (D, Figure 5-18) and the reverse belt guide (V, Figure 5-12). Then slip the upper end into the groove of the engine reverse pulley (A, Figure 5-18).
4. If the reverse belt guide (V, Figure 5-12) was loosened previously, center the belt guide on the belt and tighten the mounting screw securely.
5. Install the belt cover and secure it with the two nuts. If the lower transmission cover was removed, reinstall it with the four self-tapping screws.

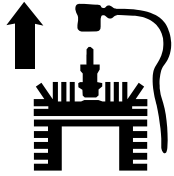

**WARNING:** Before inspecting, cleaning or servicing the machine, shut off engine, wait for all moving parts to come to a complete stop, disconnect spark plug wire and move wire away from spark plug. Failure to follow these instructions can result in serious personal injury or property damage.

## TROUBLESHOOTING

PROBLEM	POSSIBLE CAUSE	CORRECTION
<b>Engine does not start</b>	<ol style="list-style-type: none"> <li>1. Spark plug wire disconnected.</li> <li>2. Engine Throttle Control Lever incorrectly set.</li> <li>3. Fuel tank empty.</li> <li>4. Choke control (if so equipped) in incorrect position.</li> <li>5. Stale gasoline.</li> <li>6. Dirty air filter.</li> <li>7. Defective or incorrectly gapped spark plug.</li> <li>8. Carburetor out of adjustment.</li> <li>9. Misadjusted throttle control.</li> <li>10. Dirt or water in fuel tank.</li> </ol>	<ol style="list-style-type: none"> <li>1. Reconnect wire.</li> <li>2. Put lever in START position.</li> <li>3. Add fuel.</li> <li>4. See Engine Owner's Manual.</li> <li>5. Drain fuel and add fresh fuel.</li> <li>6. Clean or replace filter.</li> <li>7. Inspect spark plug.</li> <li>8. See Engine Service Dealer.</li> <li>9. See Engine Service Dealer</li> <li>10. See Engine Service Dealer.</li> </ol>
<b>Engine runs poorly.</b>	<ol style="list-style-type: none"> <li>1. Defective or incorrectly gapped spark plug.</li> <li>2. Dirty air filter(s).</li> <li>3. Carburetor out of adjustment.</li> <li>4. Stale gasoline.</li> <li>5. Dirt or water in fuel tank.</li> <li>6. Engine cooling system clogged.</li> </ol>	<ol style="list-style-type: none"> <li>1. Inspect spark plug (see Engine Owner's Manual).</li> <li>2. Clean or replace (see Engine Owner's Manual).</li> <li>3. See Engine Service Dealer.</li> <li>4. Replace with fresh gasoline.</li> <li>5. See Engine Service Dealer.</li> <li>6. Clean air cooling system (see Engine Owner's Manual).</li> </ol>
<b>Engine overheats.</b>	<ol style="list-style-type: none"> <li>1. Engine cooling system clogged.</li> <li>2. Carburetor out of adjustment.</li> <li>3. Oil level is low.</li> </ol>	<ol style="list-style-type: none"> <li>1. Clean air cooling area (see Engine Owner's Manual).</li> <li>2. See Engine Service Dealer.</li> <li>3. Check oil level (see Engine Owner's Manual).</li> </ol>
<b>Engine does not shut off</b>	<ol style="list-style-type: none"> <li>1. Misadjusted throttle control or ignition switch.</li> </ol>	<ol style="list-style-type: none"> <li>1. See Engine Owner's Manual or Engine Service Dealer.</li> </ol>
<b>Wheels and Tines will not turn</b>	<ol style="list-style-type: none"> <li>1. Improper use of controls.</li> <li>2. Forward Drive: Misadjusted forward clutch rod.</li> <li>3. Reverse Drive. Broken or misadjusted belt.</li> <li>4. Worn, Broken or misadjusted Drive Belt(s).</li> <li>5. Internal transmission wear or damage.</li> <li>6. Bolt and key loose in transmission pulley.</li> </ol>	<ol style="list-style-type: none"> <li>1. Review Sections 3 and 4.</li> <li>2. See "Handlebar Height Adjustment," Section 3.</li> <li>3. Replace belt or adjust belt tension. Section 5.</li> <li>4. See "Checking Drive Belt Tension," Section 5.</li> <li>5. Contact local dealer or the factory.</li> <li>6. Tighten bolt. Check that key is in place.</li> </ol>
<b>Tines turn, but wheels don't.</b>	<ol style="list-style-type: none"> <li>1. Wheel Drive Pins not in WHEEL DRIVE.</li> <li>2. Bolt loose in transmission pulley.</li> <li>3. Internal transmission wear or damage.</li> </ol>	<ol style="list-style-type: none"> <li>1. See "Wheel Drive Pins" in Section 3.</li> <li>2. Tighten bolt.</li> <li>3. Contact local Dealer or the Factory.</li> </ol>
<b>Wheels Turn, but Tines Don't.</b>	<ol style="list-style-type: none"> <li>1. Tine holder mounting hardware missing.</li> <li>2. Internal transmission wear or damage.</li> </ol>	<ol style="list-style-type: none"> <li>1. Replace hardware.</li> <li>2. Contact local Dealer or the Factory.</li> </ol>
<b>Poor tilling performance.</b>	<ol style="list-style-type: none"> <li>1. Worn tines.</li> <li>2. Improper Depth Regulator setting.</li> <li>3. Incorrect throttle setting or belt range speed.</li> <li>4. Belt(s) slipping.</li> </ol>	<ol style="list-style-type: none"> <li>1. See "Tines" (Section 5).</li> <li>2. See "Tilling Tips &amp; Techniques," Section 4.</li> <li>3. See Section 4.</li> <li>4. See "Checking Forward Drive Belt Tension," Section 5.</li> </ol>

# TROY-BILT TILLER LIFETIME LIMITED WARRANTY

**WHAT PRODUCT IS COVERED** All Troy-Bilt branded rear tine walk-behind tillers with gear drive transmissions. This warranty begins on the date of purchase and is warranted by Troy-Bilt LLC for the life of the tiller, to the original purchaser only.

---

**WHAT IS COVERED BY THIS WARRANTY** Troy-Bilt LLC will, at its option, repair or replace any part found to be defective in material or workmanship without charge for parts and labor

---

This limited lifetime warranty also applies to non-powered attachments and accessories. Powered attachments and accessories are warranted separately by their manufacturers. Refer to the applicable manufacturer's warranty on these items for terms and conditions.

---

**WHAT IS NOT COVERED BY THIS WARRANTY** This warranty does not apply to parts that have been damaged by accident, alteration, misuse, abuse, neglect, improper maintenance, vandalism, theft, fire, water, or damage because of peril or other natural disaster.

---

The following items are not covered after the first year of this residential use limited warranty: belts, batteries, bushings, seals, tines, tires, wheels, paint, appearance items, and similar items that are normally replaced through periodic maintenance.

Charges for pick-up, delivery, and service calls are not covered by this warranty.

Service completed by someone other than an authorized service dealer is not covered by this warranty.

Parts that are not genuine Troy-Bilt LLC service parts are not covered by this warranty.

The engine is warranted separately by the engine manufacturer. Refer to the engine manufacturer's warranty for terms and conditions.

---

**LIMITED COMMERCIAL USE WARRANTY** If used for commercial, institutional, industrial, rental, or demonstrator purposes, the warranty on the tiller is limited in duration to 90 days from the date of purchase.

This warranty does not apply to parts that have been damaged by accident, alteration, misuse, abuse, neglect, improper maintenance, vandalism, theft, fire, water, or damage because of peril or other natural disaster.

---

**HOW TO OBTAIN SERVICE** Warranty service is available, **with proof of purchase**, through your local authorized service dealer. To locate a dealer in your area, consult your Yellow Pages, or contact Troy-Bilt LLC at P.O. Box 361131, Cleveland, Ohio 44136-0019, 1-866-840-6483, or log on to our Web site at [www.troybilt.com](http://www.troybilt.com).

---

**The provisions set forth in this warranty provide the sole and exclusive remedy arising from the sale. Troy-Bilt LLC shall not be liable for any incidental or consequential damage or expense of any kind, including but not limited to cost of equipment rental, loss of profits, or costs of hiring services to perform tasks normally performed by the equipment.**

Any implied warranties, including any implied warranty of merchantability or fitness for a particular purpose, shall be limited in duration to the period of ownership by the original purchaser (and a maximum of 90 days from the date of sale if the tiller is purchased for commercial or other non-residential use).

Some states do not allow the exclusion or limitation of incidental or consequential damages, or limitations on how long an implied warranty lasts, so the above exclusions or limitations may not apply to you.

This limited warranty gives you specific legal rights, and you may also have other rights which vary from state to state.

***For customer assistance, contact your nearest authorized dealer, or contact us at:***

**TROY-BILT LLC, P.O. Box 361131, Cleveland, Ohio 44136-0019, 1-866-840-6483**



## Free Manuals Download Website

<http://myh66.com>

<http://usermanuals.us>

<http://www.somanuals.com>

<http://www.4manuals.cc>

<http://www.manual-lib.com>

<http://www.404manual.com>

<http://www.luxmanual.com>

<http://aubethermostatmanual.com>

Golf course search by state

<http://golfingnear.com>

Email search by domain

<http://emailbydomain.com>

Auto manuals search

<http://auto.somanuals.com>

TV manuals search

<http://tv.somanuals.com>