

J4F/J5F

OWNER'S MANUAL	2-10
BETRIEBSANLEITUNG	11-19
MODE D'EMPLOI	20-28
MANUALE D'USO	29-37
MANUAL DEL USUARIO	38-46
HANDLEIDING	47-55
BRUKSANVISNING	56-63
KÄYTTÖOHJE	64-71



- SERIAL NUMBER ● SERIENNUMMER
- NUMERO DE SERIE ● NÚMERO DE SERIE
- NUMERO DI SERIE ● SERIENNUMMER
- SERIENNUMMER ● SARJANUMERO

www.tunturi.com

TUNTURI[®]
THE MOTOR – *it's you.*

J4F/J5F

IMPORTANT SAFETY INSTRUCTIONS

This Owner's Manual is an essential part of your training equipment. Read all instructions before using this appliance. When using an electrical appliance, basic precautions should always be followed, including the following:

WARNING

- Never use extension cords between the treadmill and your wall outlet. The device's maximum power consumption is 2 kW. Outlets with fluctuating voltage of more than 10 % may result in erratic performance or cause damage to treadmill electronics. Using electrical power other than that, which has been specified in this manual will ultimately void any warranty, implied or otherwise.

DANGER

To reduce the risk of electric shock:

- Always unplug this appliance from the electrical outlet immediately after using and before cleaning.

WARNING

Connect this appliance to a properly grounded outlet only. See Grounding Instructions.

WARNING

To reduce the risk of burns, fire, electric shock, or injury to persons:

- 1) An appliance should never be left unattended when plugged in. Unplug from outlet when not in use, and before putting on or taking off parts.
- 2) Close supervision is necessary when this appliance is used by, on, or near children, invalids, or disabled persons.
- 3) Use this appliance only for its intended use as described in this manual. Do not use attachments not recommended by the manufacturer.
- 4) Never operate this appliance if it has a damaged cord or plug, if it is not working properly, if it has been dropped or damaged, or dropped into water. Return the appliance to service center for examination and repair.
- 5) Keep the cord away from heated surfaces.

6) Never operate the appliance with the air openings blocked. Keep the air openings free of lint, hair, and the like.

7) Never drop or insert any object into any opening.

8) Do not use outdoors.

9) Do not operate where aerosol (spray) products are being used or where oxygen is being administered.

10) To disconnect, turn all controls to the off position, then remove plug from outlet.

- Keep hands clear of any moving parts. Never place hands, feet or any other objects into any opening or under the treadmill.
- Before you start using the treadmill, make sure that it functions correctly in every way. Do not use a faulty device.

- J4F/J5F tolerates an environment measuring

+10°C to +35°C. Air humidity must never exceed 90 %.

- Do not attempt any servicing or adjustment other than those described in this manual. The given instructions must be followed carefully.

- The J4F must not be used by persons weighing over 110 kg (245 lbs). The J5F must not be used by persons weighing over 135 kg (300 lbs).

- J4F/J5F is designed for household use only. The warranty of 24 months applies only for faults in household use.

SAVE THESE INSTRUCTIONS!

WELCOME TO THE WORLD

OF TUNTURI EXERCISING!

Your choice shows that you really want to invest in your well-being and condition; it also shows you really value high quality and style. With Tunturi Fitness Equipment, you've chosen a high-quality, safe and motivating product as your training partner. Whatever your goal in training, we are certain this is the training equipment to get you there. You'll find information about using your exercise equipment and what makes for efficient training at Tunturi's website at www.tunturi.com.

ASSEMBLY

Before assembling the device, insure all parts are present:

1. Frame
2. Handlebars (2)
3. Horizontal handlebar
4. Meter
5. Power cord
6. Assembly kit (contents are marked with an * in the spare part list): keep the assembly tools, as you may need them e.g. for adjusting the equipment

In case of problems contact your Tunturi dealer. The directions left, right, front and back are

defined as seen from the exercising position. To avoid injury, you must fold up the deck prior to lifting the treadmill out of the box.

HANDRAILS

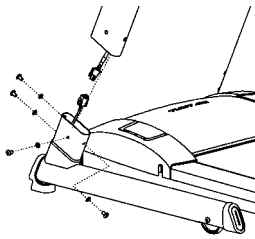

Connect the wires before you assemble the handrails. Secure each handrail with four washers and bolts. **NOTE:** Do not tighten these bolts until the horizontal handlebar and monitor have been secured.

HORIZONTAL HANDLEBAR

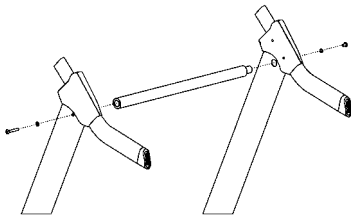

The horizontal handlebar (rod) is tapered on one side. Insert the tapered end of the rod into the right handrail before fitting the rod into the left side. **NOTE:** the left side is secured with the long bolt while the right side is secured with the short bolt. Do not tighten these bolts until the monitor has been secured.

MONITOR

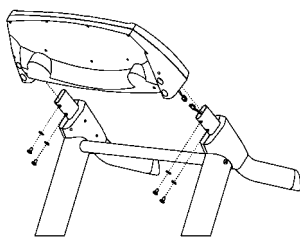

Connect the wire. After connecting the wire thread it into the handlebar then push the monitor onto the handrails. You may have to shake the handrails from side to side to get the monitor to fit. Once you have the monitor in place, secure and tighten the bolts on the monitor. Tighten all bolts. Remove the protective film from the display.

POWER CORD AND GROUNDING

INSTRUCTIONS

Plug the socket end of the power cord into the treadmill at the left front corner. Before connecting

the device to a power source, make sure that local voltage matches that indicated on the type plate. The treadmill operates at 230 V or 120 V. Turn on the power using the switch next to the socket on the treadmill. This treadmill must be grounded. If it should malfunction or breakdown, grounding provides a path of least resistance for electrical current to reduce the risk of electrical shock. This product is equipped with a cord having an equipment-grounded conductor and a grounding plug. The plug must be plugged into an appropriate outlet that is properly installed and grounded in accordance with all local codes and ordinances. Do not use extension cables when connecting the equipment to the power source.

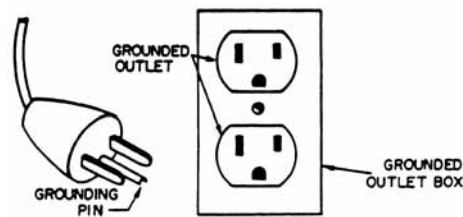

DANGER! Improper connection of the equipment-grounding conductor can result in a risk of electric shock. Check with a qualified electrician or serviceman, if you are in doubt as to whether the product is properly grounded. Do not modify the plug provided with the product - if it will not fit the outlet, have a proper outlet installed by a qualified electrician.

If the product is for use on a nominal 120-volt circuit, it has a grounding plug that looks like the plug illustrated. Make sure that the product is connected to an outlet having the same configuration as the plug. No adapter should be used with this product.

SAFETY TETHER KEY

The treadmill cannot be used if the tether key is not properly installed on the meter; if the key is removed from its place, the treadmill will immediately stop. Insert the safety tether key into the key holder at the left side of the meter. Ensure that the clip of the safety tether key is properly attached to your clothing; as the cord tightens, make sure the clip does not detach itself from your clothing before the safety tether key disconnects from the user interface. Always hold the handrail for support when getting off the treadmill. Do not jump off the running belt while it is moving!

METER

See back fold.

FUNCTION KEYS

SELECT

Before you press the Start key, Select key selects the training modes (Manual / HRC) or programs.

ENTER

Confirm your selections (training mode or program, user set-ups)

START

Starts the selected training and activates the running belt at the speed of 1,0 km/h / mph.

SPEED CONTROL KEYS (ARROW KEYS)

Hare key increases the belt speed in 0,1 km/h / mph increments, the tortoise key decreases it in 0,1 km/h / mph increments. Pressing these keys longer makes the speed change faster. Track speed ranges from 1,0-16,0 km/h / 0,6-10 mph. In user settings, you can adjust the values with the speed control keys. In HRC mode, you can scale the target HR with the speed control keys. In exercise profiles, you can scale the effort level with the speed control keys. Pressing the Hare key will increase the effort at 5% steps, and pressing the Tortoise key will decrease the effort at 5% steps.

ELEVATION CONTROL KEYS

Click the elevation up key to increase elevation in 0,5 % increments, and the elevation down key to decrease it in 0,5 % increments. Pressing these keys longer makes the speed change faster. Track elevation ranges from 0 % (horizontal) to 10 %. After the meter has been switched on, pressing both elevation control keys simultaneously will open user settings.

SCAN/HOLD

The values displayed change at 6-second intervals. If you want to monitor any value for a longer period, press the Scan/Hold key, and the display will be locked. When you want to view the changing values again, press the Scan/Hold key to unlock.

STOP/PAUSE

Press Stop/Pause once and the treadmill stops and moves into its waiting state for 5 minutes. You can restart the interrupted exercise by pressing the Start key within 5 minutes. Press Stop/Pause twice to end your exercise. Keep the Stop key pressed down for 2 seconds to reset the meter. The meter then switches to its initial state.

DISPLAYS

The meter alternates within three display combinations at 6 second intervals: elevation/ heart rate / speed, time / distance / energy consumption, and time / heart rate / speed. Press Scan/Hold once to hold the display. By pressing it for a second time, the displays are released and start to alternate again.

TIME

exercise duration at 1 second intervals 00:00-99:59, and at 1 minute intervals thereafter h1:40-h9:59

ELEVATION

0-10 %, 0,5 % increment

DISTANCE

0.00-99.99 km, 0,01 km increment

HEART RATE

45-220 bpm. The heart rate light always blinks when the meter is receiving a heart rate signal.

KCAL (estimated energy consumption)

0-999 kcal, 1 kcal increment

SPEED

running deck speed (1,0-16,0 km/h / 0,6-10 mph), 0,1 km / mph increment

GRAPHIC/TEXT DISPLAY

When you switch to an exercise, the display provides instructions in English, and during the workout the display shows information about the exercise.

BASICS ON EXERCISING

ABOUT YOUR HEALTH

- Before you start any training, consult a physician to check your state of health.
- If you experience nausea, dizziness or other abnormal symptoms while exercising, stop your workout at once and consult a physician.
- To avoid muscular pain and strain, begin and end each workout by stretching.

ABOUT THE EXERCISE ENVIRONMENT

- Make sure the exercise environment has adequate ventilation. To avoid catching cold, do not exercise in a draughty place.
- Place the treadmill on a firm, level surface. Allow 100x200 cm of clearance behind the treadmill and 100 cm on either side and in front of the treadmill.
- We recommend that the equipment is placed on a protective base.

ABOUT USING THE EQUIPMENT

- Always unplug the treadmill from the electrical outlet after each training session.
- Only one person may use the equipment at a time.
- Keep hands clear of any moving parts. Never place hands, feet or any other objects under the treadmill.
- Wear appropriate clothing and shoes when exercising. Make sure your shoelaces are properly tied. To avoid injury and unnecessary wear on your treadmill, be sure your shoes are free of any debris such as gravel and small pebbles.

BEGINNING AN EXERCISE SESSION

- To avoid muscular pain and strain, begin and end each workout by stretching.
- Stand on the landing rails to the left and right of the running belt. Do not stand on the running belt.
- Always hold the handrail for support when getting on or off the treadmill and when changing the speed during exercise. Do not jump off the running belt while it is moving!
- If you experience nausea, dizziness or other abnormal symptoms while exercising, stop your workout at once and consult a physician.

FINISHING AN EXERCISE SESSION

- Never leave the safety tether key in the treadmill.
- Use the main power switch to turn the unit off.
- Unplug the electrical cord from the wall outlet and from the treadmill.
- If necessary clean the treadmill from sweat with a damp cloth. Do not use solvents.
- Store the electrical cord where it is clear from all pathways and out of childrens' reach.

HOW TO MOTIVATE YOURSELF TO

CONTINUE

In order to reach the goals you have set, you'll need to keep finding the motivation to continue so you achieve your ultimate goal: life-long health and a new quality of living.

- Set yourself realistic targets.
- Progress step-by-step according to your schedule.
- Keep a fitness diary and write down your progress.
- Change your way of exercising from time to time.
- Use your imagination.
- Learn self-discipline.

One important aspect of your training is versatility. Varying your training exercises different muscle groups and helps maintain motivation.

HEART RATE

This equipment has a built-in pulse receiver, which is compatible with a Polar T 31/ T41 telemetric pulse transmitter.

No matter what your goal, you'll get the best results by training at the right level of effort, and the best measure is your own heart rate. First find your maximum heart rate i.e. where the rate doesn't increase with added effort. If you don't know your maximum heart rate, please use the following formula recommended by the American College of Sports Medicine (ACSM) as a guide:

208 - 0,7 X AGE

This is an average value and the maximum varies from person to person. The maximum heart-rate diminishes on average by one point per year. If you belong to a risk group, ask a doctor to measure your maximum heart rate for you. We have defined three different heart-rate zones to help you with targeted training.

BEGINNER : 50-60 % of maximum heart-rate
Also suitable for weight-watchers, convalescents and those who haven't exercised for a long time. Three sessions a week of at least a half-hour each is recommended. Regular exercise considerably improves beginners' respiratory and circulatory performance and you will quickly feel your improvement.

TRAINER : 60-70 % of maximum heart-rate
Perfect for improving and maintaining fitness. Even reasonable effort develops the heart and lungs effectively, training for a minimum of 30 minutes at least three times a week. To improve your condition still further, increase either frequency or effort, but not both at the same time!

ACTIVE TRAINER : 70-80 % of maximum heart-rate

Exercise at this level suits only the fittest and presupposes long-endurance workouts.

When selecting training attire, please note that some fibers used in clothes (e.g. polyester, polyamide) create static electricity which may prevent reliable heart rate measurement.

Please note that a mobile phone, television and other electrical appliances form an electro-magnetic field around them which will cause problems in heart rate measurement.

EXERCISING ON J4F/J5F TREADMILL

To switch on the power to the treadmill, connect the power cord between the connector at the front of the treadmill and a wall socket, and then press the power switch to the on position. The switch will light up.

ENTERING USER DETAILS

Press both the elevation control keys simultaneously to go to user details setting. An English-language info text will appear in the text field, which changes according to the value to be set. Press Enter to start.

1. Set gender (male, female). Use the arrow keys to change the setting, and press Enter to confirm your selection. You will then move to the next setting.

This information is needed for estimating energy consumption.

2. Set the age of the user. Use the arrow keys to change the setting, and press Enter to confirm your selection. You will then move to the next setting. This information is needed for estimating energy consumption.
3. Set the measurement units (Metric = metric system, Imperial = avoirdupois). Use the arrow keys to change the setting, and press Enter to confirm your selection. You will then move to the next setting.
4. Set the audio signal (**ON** = signals on, **OFF** = signals off). Use the arrow keys to change the setting, and press Enter to confirm your selection. You will then move to the next setting.
5. The **TOTAL TIME** display shows the total usage time period of the treadmill. The value cannot be changed. Press Enter to move to the next display.
6. The **TOTAL DISTANCE** display shows the total distance run on the treadmill. The value cannot be changed. Press Enter to return to gender setting or press Start to exit user settings.

CHOOSING AN EXERCISE

To switch on the power to the treadmill, connect the power cord between the connector at the front of the treadmill and a wall socket, and then press the power switch to the on position. The switch will light up. Make sure that the safety tether key is in place. Press Select until the signal light indicates the desired exercise. You can choose between:

1. Manual exercise in which you adjust both speed and elevation yourself during the exercise.
2. Heart rate controlled HRC exercise in which the treadmill adjusts the speed / elevation automatically, so that your heart rate stays at the level set. You always need to wear a heart rate belt while doing HRC exercises.
3. Preset exercise profile in which speed/elevation or heart rate level vary according to the preset program.

MANUAL EXERCISE

1. Manual exercise is the treadmill default setting.
2. Press Enter and set the user weight with the arrow keys. Press Enter to confirm your setting. The setting will remain in the meter's memory until replaced with a new one.
3. Press Start. The belt starts moving at 1.0 km/h / 0,6 mph. Use the Hare/Tortoise keys to adjust the speed and the elevation control keys to adjust the elevation.
4. Press Stop/Pause and the treadmill stops and moves into waiting state for 5 minutes. You can restart the interrupted exercise by pressing the Start key within 5 minutes. Press Stop/Pause twice to end your exercise. Keep the Stop key pressed down

for 2 seconds to reset the meter. The meter then switches to its initial state.

If the user weight does not need to be adjusted, you can start the exercise directly by pressing the Start key. The profile display collects the exercise speed details at one minute intervals. After 16 minutes, the display will shift to the left to show the speed details from the last 16 minutes.

HEART RATE CONTROLLED EXERCISE

1. Heart rate controlled exercises always require the use of a heart rate belt. If heart rate measurement is not working correctly, the error message HR ERROR will be displayed. You should then make sure that you have properly followed the instructions on the use of the heart rate belt.
2. Press Select until the signal light shows next to the HRC text.
3. Press Enter to move to the heart rate exercise setting. The latest heart rate exercise value is shown on the display in the middle. You can adjust the value with the Hare/Tortoise keys. Press Enter to confirm your setting. The setting will remain in the meter's memory until replaced with a new one.
4. Press Enter and set the user weight with the Hare/Tortoise keys. Press Enter again to confirm your selection. That setting will remain in the meter's memory until it is replaced with a new one.
5. Press Start. The exercise begins and the belt starts moving.
6. If the set heart rate value seems too strenuous or easy, change the heart rate value by using the Hare/Tortoise keys.
7. Press Stop/Pause and the treadmill stops and moves into waiting start for 5 minutes. You can restart the interrupted exercise by pressing the Start key within 5 minutes. Press Stop/Pause twice to end your exercise. Keep the Stop key pressed down for 2 seconds to reset the meter. The meter then switches to its initial state.

If the exercise heart rate and user weight do not need to be adjusted, select HRC mode and press Start to begin heart rate controlled exercise. The profile display collects the heart rate details of the exercise at one minute intervals. After 16 minutes, the display will shift to the left to show the heart rate details from the last 16 minutes.

EXERCISE PROFILES

Tunturi has developed different preset exercise profiles in order to ensure versatile, pleasant and goal-oriented training. The shape of the different profiles is shown in the back fold and on the key panel of the meter, and the meter also provides more detailed information about the selected profile during the exercise. The meter gives an audio signal in advance of changes in a profile. The

profile display shows the shape of the profile and the details of the next profile bar.

A. Hill Walk, Hill Jog and Hill Run are exercise profiles with different effort levels where you can scale the effort level to what you require and set the duration of the exercise.

1. The Hill profiles do not require the use a heart rate belt, but that provides interesting additional information about your performance.
2. Press Select until the signal light shows next to the Hill profile you want.
3. Press Enter to move to profile duration setting. The previous duration set is shown on the left-hand side number display. You can change the value using the arrow keys (limit 10 minutes (10:00) - 3 hours (h3:00), adjusting at 5 minute steps). Press Enter to confirm your selection. The setting will remain in the meter's memory until replaced with a new one.
4. Press Enter and set the user weight using the arrow keys. Press Enter again to confirm your selection The setting will remain in the meter's memory until replaced with a new one.
5. Press Start. The exercise begins and the belt starts moving.
6. You can scale the the profile speed level up and down at 5% steps using the arrow keys.
7. Press Stop/Pause and the treadmill stops and moves into waiting state for 5 minutes. You can restart the interrupted exercise by pressing the Start key within 5 minutes. Press Stop/Pause twice to end your exercise. Keep the Stop key pressed down for 2 seconds to reset the meter. The meter then switches to its initial state.

If the profile duration and user weight do not need to be adjusted, you can start the exercise by selecting the Hill profile you want and pressing Start.

B. Rolling Hills is an interval exercise in which you can set the distance to be run during the exercise.

1. The profiles do not require the use of a heart rate belt, but that provides interesting additional information about your performance.
2. Press Select until the signal light shows next to the Rolling Hills text.
3. Press Enter to move to profile duration setting. The previous distance set is shown on the number display in the middle. You can change the value using the arrow keys. The default is 3 km (limits 3 kilometers - 42 kilometers, adjusting at 1 kilometer steps). Press Enter to confirm your selection. The setting will remain in the meter's memory until replaced with a new one.
4. Press Enter and set the user weight using the arrow keys. Press Enter again to confirm your selection The setting will remain in the meter's memory until replaced with a new one.

5. Press Start. The exercise begins and the belt starts moving. Use the speed control keys to adjust the speed.

6. Press Stop/Pause and the treadmill stops and moves into waiting state for 5 minutes. You can restart the interrupted exercise by pressing the Start key within 5 minutes. Press Stop/Pause twice to end your exercise. Keep the Stop key pressed down for 2 seconds to reset the meter. The meter then switches to its initial state.

If the profile duration and user weight do not need to be adjusted, you can start the heart rate controlled exercise by selecting the Rolling Hills profile and pressing Start.

C. The Fatburners, Cardio (fitness maintenance) and Fit (fitness improvement) profiles are heart rate controlled exercise profiles with different effort levels that allow you to set the duration of the exercise.

1. The heart rate controlled profiles Fatburner, Cardio and Fit always require the use of a heart rate belt. If heart rate measurement is not working correctly, the error message HR ERROR will be displayed. You should then make sure that you have properly followed the instructions on the use of the heart rate belt.
2. Press Select until the signal light shows next to the profile you want.
3. Press Enter to move to profile duration setting. The previous duration set is shown on the left-hand side number display. You can change the value using the arrow keys (limit 10 minutes (10:00) - 3 hours (h3:00), adjusting at 5 minute steps). Press Enter to confirm your selection. The setting will remain in the meter's memory until replaced with a new one.
4. Press Enter and set the user weight using the arrow keys. Press Enter again to confirm your selection The setting will remain in the meter's memory until replaced with a new one.
5. Press Start. The exercise begins and the belt starts moving.
6. You can scale the the profile speed level up and down at 5% steps using the arrow keys.
7. Press Stop/Pause and the treadmill stops and moves into waiting state for 5 minutes. You can restart the interrupted exercise by pressing the Start key within 5 minutes. Press Stop/Pause twice to end your exercise. Keep the Stop key pressed down for 2 seconds to reset the meter. The meter then switches to its initial state.

If the profile duration and user weight do not need to be adjusted, you can start the exercise by selecting the Hill profile you want and pressing Start.

MAINTENANCE

The equipment is safe to use only when periodically maintained and inspected for faults and wear. **CAUTION!** Do not attempt any servicing or adjustment other than those described in this manual. Any other servicing must be performed by an authorized service representative. Check the tightness of all fixing screws once a year. Do not overtighten. Defective components must be immediately replaced; the equipment must not be operated with any defective components.

LUBRICATING THE RUNNING DECK

Lubrication is the most important service activity for the treadmill. This is absolutely essential, if the friction of the running deck increases noticeably or the motor begins to heat up; increased friction is indicated by jerky movement of the belt. Insufficient lubrication will cause the belt, running deck and motor to wear out and break. The need for re-lubrication depends to a great extent on the running styles and weight of the user: heavy user weight and slow speed put particular strain on the device and therefore demand greater lubrication. The running deck requires periodic lubrication. With average usage (30 minute workout session 3 times a week), lubricate every four to six months. You may adjust the timing of the lubrication based on the intensity of the treadmill use level. To check the lubrication level, simply lift the running belt, and put your hand as far into the center of the belt as you can reach. If your hand shows signs of lubricant (some wetness), then it does not need additional lubrication. If the board feels dry and there is very little evidence of lubricant on your hand, then additional lubrication should be added as instructed:

1. Stop running belt so belt seam is located on the top and in the center of the deck.
2. Insert nozzle into spray head of lubricant can.
3. Lift running belt.
4. Position nozzle between the belt and the board approximately 200 mm (8") from the front of the treadmill.
5. Apply T-Lube from the front to the rear of the treadmill on each side of the treadmill. Try to reach the spray as far into the center of the running deck as possible.
6. The treadmill is instantly ready for use.

NOTE! Lubricate your treadmill only with T-Lube lubricant. Contact your local Tunturi distributor for supplies of T-Lube.

CLEANING THE TREADMILL

Wipe the treadmill surfaces, especially the handlebars and meter from dust with a damp cloth

or towel. Do not use solvents. Use a small vacuum nozzle to carefully vacuum around all visible components (belt, running deck, side rails etc.). To clean the underside of the treadmill, lift the running deck to the storage position.

NOTE! Also keep the area near the treadmill clean. While in use, the treadmill gathers dust that may cause problems in the operation of the equipment.

ALIGNING THE RUNNING BELT

Monitor belt tracking during exercise and make adjustments as needed. The belt should run in the center of the treadmill. Alignment is not usually needed, provided

- the treadmill is placed on an even, solid and horizontal surface and the belt is correctly tensioned
- the alignment of the belt is correct

It is, however, possible for the belt to be pushed to one side due to the user's running style (e.g. more weight on one foot). The alignment of the belt is adjusted by turning the two bolts at the back of the treadmill.

Align the belt according to the following instructions:

1. Turn the power switch on and increase the treadmill's speed to 5 km/h (3 mph).
2. If the belt drifts to the left, turn the left adjustment bolt 1/4 turn clockwise and the right adjustment bolt 1/8 turn anti-clockwise. If the belt drifts to the right, turn the right adjustment bolt 1/4 turn clockwise and the left adjustment bolt 1/4 turn anti-clockwise.
3. If the belt remains centered the adjustment is correct. If not, continue to make small adjustments as above until the belt is correctly aligned. If the belt is allowed run across to one side for long periods of time the edges of the belt may be damaged and the treadmill may not continue to operate correctly. Any damage to the belt caused by the lack of necessary adjustment will not be covered by the warranty.

ADJUSTING THE BELT TENSION

The belt must be tensioned if it begins to slip on the rollers. In normal use, however, keep the belt as loose as possible! The belt tension is adjusted by turning the same screws as used for aligning the running belt. If turning the screws will not effect the belt tension, please contact your local Tunturi dealer.

1. Increase the treadmill's speed to 5 km/h (3 mph).
2. Turn both adjustment screws an equal amount, 1/4 turn clockwise.
3. Try to slow the belt down by holding onto the

handrails and braking as you walk (as if you were walking downhill). If the belt slips, turn another 1/4 turn and repeat the test. When braking heavily the belt may slip. If the belt keeps slipping despite repeated adjustments, please contact your local Tunturi dealer.

MALFUNCTIONS

NOTE! Despite continuous quality control, defects and malfunctions caused by individual components may occur in the equipment. In most cases it's unnecessary to take the whole device in for repair, as it's usually sufficient to replace the defective part. Always give the model, serial number of your equipment and in case of malfunctions also conditions of use, nature of malfunction and any error code.

When you encounter unusual behavior from the treadmill, simply turn the power switch off, wait 1 minute and turn the power switch on to reset the treadmill. This should clear incidental errors and ready the treadmill for normal operation again. If after you have reset the treadmill by turning the power switch off and on again, and the treadmill is still not operational, contact your local Tunturi dealer for service.

If you require spare parts, always give the model, serial number of your equipment and the spare part number for the part you need. The spare part list is at the back of this manual. Use only spare parts mentioned in the spare part list.

ERROR CODES

The user interface will display information about any operational faults.

ERROR 1: speed sensor error. Turn the power switch off and on again to reset the treadmill. If treadmill recovers to normal operation, you may continue to use the treadmill. If treadmill does not recover to normal operation, then call the dealer for service.

ERROR 2: over speed error. Call your dealer for service.

ERROR 3: safety key error. Secure the safety key in place and continue training.

ERROR 5: Incline motor error.

Turn the power switch off and on again to reset the treadmill. Press simultaneously -, + and elevation down keys for automatic self-calibration. Press the Stop key for 2 seconds to exit. If treadmill recovers to normal operation, you may continue to use the treadmill. If treadmill does not recover to normal operation, then call the dealer for service.

ERROR 11: Communication error. Turn the power switch off and on again to reset the treadmill. If treadmill recovers to normal operation, you may continue to use the treadmill. If treadmill does not

recover to normal operation, then call the dealer for service.

OVERLOAD PROTECTOR

If the treadmill's power consumption becomes too great, the overload protector will cut the power supply as a safety measure. The fuse button next to the power switch will spring up. Before you continue using the equipment, first check the lubrication of the track, as well as any other mechanical reason that could have caused the overload protector to cut in. Push the fuse button down. The treadmill is now ready for use again.

MOVING AND STORAGE

Folding and unfolding of this treadmill is easy. After the treadmill has come to a complete stop, ensure that the running deck elevation is 0 %, unplug the power cord from the wall and the treadmill. Fold up the deck; when you hear a click, the deck is locked in place. The lock release handle is on the left-hand side of the rear support. Release the running track lock by pulling the handle down. To release the folding lock, support the deck with your right hand while you release the lock with your left hand. Deck is ready to be positioned horizontally on the ground.

NOTE! Please handle with caution although it is designed with the gas cylinder taking most of the weight off the deck.

Before moving J4F/J5F, be sure the power cord is unplugged from the wall and the treadmill. Fold up the running deck until it is locked and push the equipment on the transportation wheels. Lower the treadmill carefully onto the floor.

NOTE! Transport the treadmill with extreme caution over uneven surfaces, for example over a step. The treadmill should never be transported upstairs using the wheels over the steps, instead it must be carried.

NOTE! The running belt needs to be realigned and centered after moving.

To prevent malfunctioning of the treadmill, store it in a dry place with as little temperature variation as possible, protected against dust. Always unplug the treadmill from the electrical outlet when not in use.

TECHNICAL DATA

J4F/J5F treadmill meets the requirements of the EU's EMC Directives on electromagnetic compatibility (89/336/EEC) and electrical equipment designed for use within certain voltage

limits (73/23/EEC). This product therefore carries the CE label.

Due to our continuous policy of product development, Tunturi reserves the right to change specifications without notice.

CAUTION! The instructions must be followed carefully in the assembly, use and maintenance of your equipment. The warranty does not cover damage due to negligence of the assembly, adjustment and maintenance instructions described herein. Changes or modifications not expressly approved by Tunturi Oy Ltd will void the user's authority to operate the equipment!

J4F

Length (storage position)... 186 cm (106 cm) /
..... 73,5" (41,5")
Height (storage position) .. 142 cm (165 cm) /
..... 55,9" (65")
Width 74 cm / 29"
Weight 90 kg / 198 lbs
Running surface 43 cm x 130,5 cm /
..... 17" x 51"
Speed 1,0-16 km/h /
..... 0,6-10 mph
Elevation range..... 0-10 %
Motor (continuous duty)... 2,0 hv (1,49 kW)

J5F

Length (storage position)... 193 cm (106 cm) /
..... 76" (41,7")
Height (storage position) .. 142 cm (172 cm) /
..... 55,9" (67,7")
Width 84 cm / 32,9"
Weight 108 kg / 248 lbs
Running surface 51 cm x 130,5 cm /
..... 20" x 51"
Speed 1,0-16 km/h /
..... 0,6-10 mph
Elevation range..... 0-10 %
Motor (continuous duty)... 2,0 hv (1,49 kW)

We wish you many enjoyable trainings with your new Tunturi training partner!

J4F

1	233 4027	User interface (incl. 118)	1
2	173 4070	Handle bar cover, L pair	1
3	173 4071	Handle bar cover, R pair	1
4	M3x10 DIN 7985	Screw	6
5	M8 DIN 6798 I	Star washer (14 pcs)	16
*6	M8x15 ISO 7380	Allen head bolt	13
7	213 4015	Handle grip	2
8	533 4075	Handlebar end cap	2
9	203 4039	Upright post welded, R	1
10	203 4041	Horizontal bar (incl. 116)	1
11	203 4040	Upright post welded, L	1
*12	M8x55 ISO 7380	Allen head bolt	1
13	403 4115	Cable, set (incl. 98)	1
15	403 4099	Safety key	1
16	M5x10 DIN 7985	Screw	6
17	173 4067	Motor cover	1
18	M4x8 DIN 7985	Screw	2
21	403 4117	Micro switch (incl.19, 20, 22)	1
23	M4x8 DIN 7985	Screw	14
24	M5 DIN 127	Spring washer	2
25	403 4106	Sensor cable	1
26	813 4026	Motor, 230V 1,5 HP	1
-	813 4027	Motor, 110V 1,5 HP	1
27	503 4046	Motor bracket	1
28	M8x20 DIN 912	Head allen key bolt	2
29	403 4120	Circuit breaker, 230V	1
-	403 4124	Circuit breaker, 110V	1
30	M8 DIN 934	Nut	1
31	M8x40 DIN 912	Head allen key bolt	3
32	653 4056	Screw	4
33	M6 DIN 137B	Curve washer	2
34	343 4016	Lift motor shaft	1
35	813 4024	Lift motor, 230V (.34, 36-38)	1
-	813 4028	Lift motor, 110V (34, 36-38)	1
37	653 4055	Nut (incl. 36)	1
38	2 DIN 11024	Pin	1
39	403 4110	Power board, 230V	1
-	403 4123	Power board, 110V	1
40	403 4118	Capacitor	1
41	403 4121	Mains cable socket	1
42	403 4122	Mains switch	1
43	M4x6 DIN 7985	Phillips head screw	2
44	443 4017	Drive belt	1
45	443 4016	Running belt	1
46	523 4040	Rear roller	1
47	M8x30 DIN 912	Head allen key bolt	2
48	M8 DIN 137 B	Curve washer	2
49	523 4039	Front roller	1
50	M6x25 DIN 7985	Screw	8
51	653 4054	Washer	8
52	433 4031	Running deck	1
53	433 4033	Anti-slip mat (incl. 106)	1
54	433 4032	Side landing (incl. 55)	2
56	503 4047	Deck bracket	2
57	M4x8 DIN 7985	Screw	4
58	533 4053	Rubber bumper	6
59	M8x50 ISO 7380	Screw	3
60	523 4041	Moving wheel sleeve	2
61	173 4068	Right rear end cap (incl. 62)	1
63	M4x15 DIN 7985	Screw	6
64	M8 DIN 985	Nylock nut	11
65	M8 DIN 9021	Washer	12
66	173 4069	Left rear end cap (incl. 67)	1
68	M6x10 DIN 7985	Screw	2
69	533 4063	Moving wheel	2
70	373 4008	Release lever (incl. 71-73)	1
74	223 4004	Cable, release (incl. 93, 94)	1
75	M8x65 DIN 912	Screw	2
76	M8x20 DIN 912	Head allen key bolt	6
78	503 4043	Incline support link br. (incl.77)	1
79	M8x30 DIN 912	Head allen key bolt	2
80	533 4066	Incline wheel	2
81	503 4044	Incline wheel bracket	1
82	103 4043	Incline structure frame	1
83	343 4013	Moving shaft	1
84	533 4067	Connection tube bushing	2
85	533 4068	Bushing spacer	2
86	533 4069	Track slider	2
87	343 4014	Fixed shaft	1
88	533 4070	Spacer	8
89	103 4044	H-frame	1
90	163 4006	Cas spring	2
91	M5x40 DIN 912	Screw	2
92	533 4071	Lock pin cap, L	1
95	533 4074	Frame end cap, R	1
96	533 4072	Snap bushing	3
97	103 4041	Main frame	1
99	533 4061	Base frame end cap	2
100	M6x15 DIN 7985	Screw	6
101	M6x40 DIN 912	Screw	2
102	533 4073	Track stopper	2
103	103 4042	Base frame	1
104	343 4015	Incline linkage shaft	1
105	533 4065	PVC foot	2
107	523 4044	Wheel sleeve	2
108	533 4064	Base frame end cap	2
109	533 4062	Base frame wheel	2
110	16 DIN 471	E-clip	2
111	813 4025	Choke, EUR	1
112	M3x6 DIN 7985	Screw	4
113	M3 DIN 127	Spring washer	4
114	403 4116	EMI filter, EUR (incl. 115)	1
116	213 4016	Handle grip horizontal	1
117	173 4076	Lower cover	1
118	233 4030	Membrane	1
*	403 4104	Power cable, EUR	1
*	403 4125	Power cable, USA	1
*	423 4091	Lable set	1
*	553 4020	Assembly kit (incl *)	1
-	583 4028	Owner's manual	1

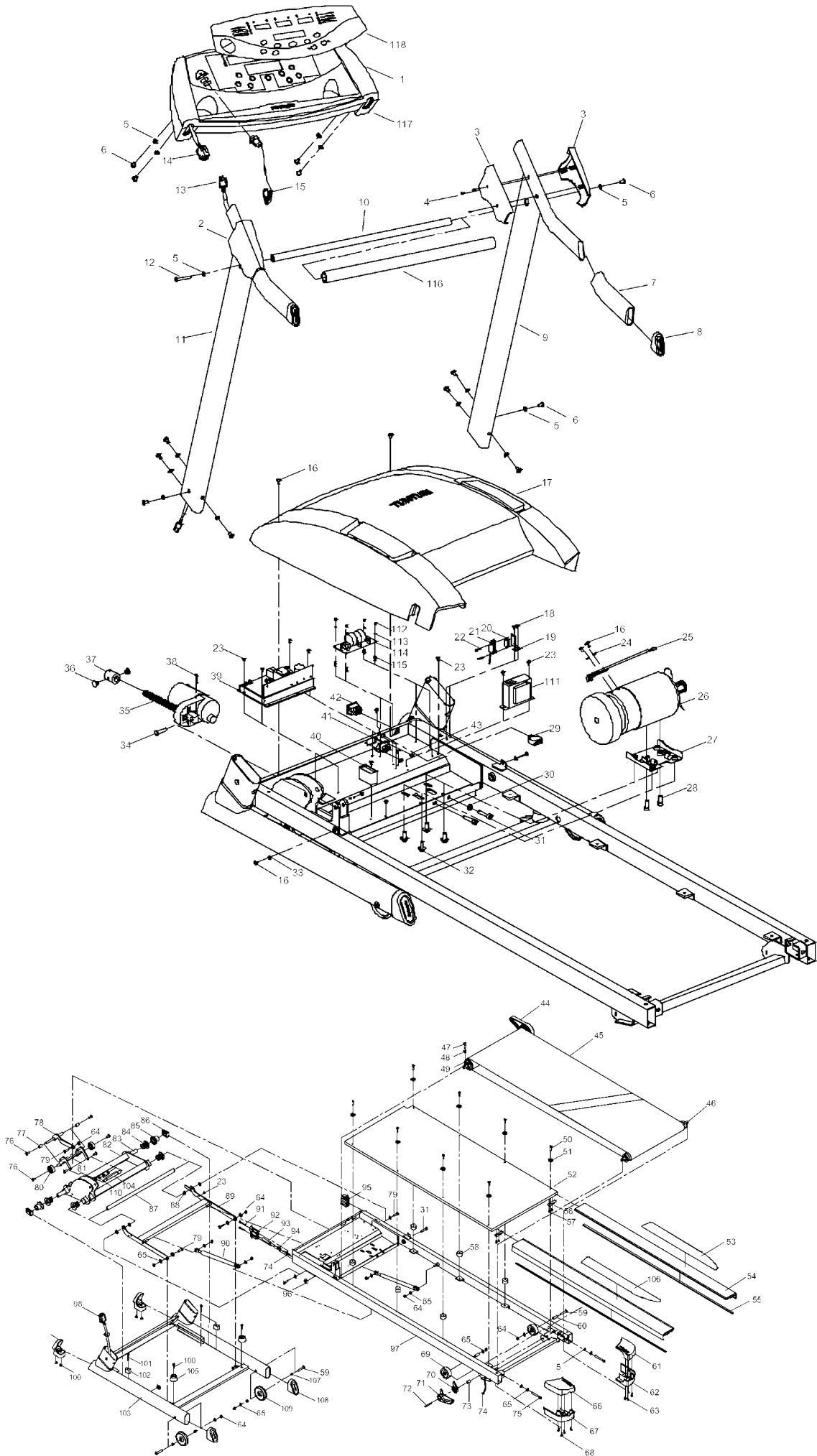

J5F

1	M6x15 DIN 7985	Screw	4	69	M8x20 DIN 912	Head allen key bolt	2
2	533 4061	Base frame end cap	2	70	653 4056	Screw	4
4	533 4072	Snap bushing	2	71	M8x50 DIN 912	Head allen key bolt	3
5	M6x25 DIN 7985	Screw	10	72	M8 DIN 934	Nut	1
6	533 4065	PVC foot	2	73	403 4120	Circuit breaker, 230V	1
7	M8x50 ISO 7380	Dome head bolt	3	-	403 4124	Circuit breaker, 110V	1
8	523 4044	Wheel sleeve	4	74	M4x6 DIN 7985	Phillips head screw	2
9	533 4062	Base frame wheel	2	75	403 4121	Mains switch	1
10	M8 DIN 6798 I	Star washer (14 pcs)	24	76	403 4118	Capacitor, 230 V	1
11	M8 DIN 125	Washer	12	-	403 4139	Capacitor, 110 V	1
12	M8 DIN 985	Nylock nut	12	77	403 4122	Mains cable socket	1
13	533 4064	Base frame end cap	2	78	173 4082	Motor cover	1
14	103 4056	Base frame	1	79	M6 DIN 127	Spring washer	2
15	M5x40 DIN 912	Head allen key screw	2	80	M8x40 DIN 912	Head allen key bolt	1
16	533 4071	Lock pin cap, L	1	81	M8x30 DIN 912	Head allen key bolt	1
19	223 4004	Cable, release (incl. 17, 18)	1	82	M8 DIN 137 B	Curve washer	1
20	533 4074	Frame end cap, R	1	83	523 4052	Front roller	1
21	533 4053	Rubber bumper	6	84	443 4017	Drive belt	1
24	373 4008	Release lever (incl. 22, 23, 25)	1	85	443 4019	Running belt	1
26	533 4063	Moving wheel	2	86	523 4053	Rear roller	1
27	523 4041	Moving wheel sleeve	2	87	M4x15 DIN 7985	Screw	8
28	103 4055	Main frame	1	88	653 4059	Washer	8
*29	M8x15 ISO 7380	Dome head bolt	19	89	433 4037	Running deck	1
31	503 4043	Incline support link (incl. 30)	1	90	503 4051	Deck bracket	2
32	533 4066	Incline wheel	2	91	M5x10 DIN 7985	Screw	4
33	M8x30 ISO 7380	Dome head bolt	6	92	M6x10 DIN 912	Head allen key screw	2
34	503 4044	Incline wheel bracket	1	93	433 4033	Anti-slip mat (incl. 94)	1
35	533 4069	Track slider	2	95	433 4038	Side landing (incl. 96)	2
36	533 4068	Bushing spacer	2	97	173 4068	Right rear end cap (incl. 98)	1
37	533 4067	Connection tube bushing	2	99	M4x20 DIN 7985	Screw	6
38	343 4017	Moving shaft	1	100	M6x10 DIN 7985	Screw	2
39	103 4057	Incline structure frame	1	102	173 4069	Left rear end cap (incl. 101)	1
40	16 DIN 471	E-clip	2	103	M8x65 DIN 912	Head allen key bolt	2
41	343 4015	Incline linkage shaft	1	104	233 4027	User interface, EUR (incl. 129)	1
42	343 4018	Fixed shaft	1	-	233 4034	User interface, USA (incl. 129)	1
43	103 4058	H-frame	1	105	173 4085	Console rubber, pair (incl.120)	1
44	533 4070	Spacer	8	106	173 4084	Handle bar cover, R pair	1
45	M4x8 DIN 7985	Screw	16	107	213 4015	Handle grip	2
46	163 4007	Gas shock	2	108	533 4075	Handlebar end cap	2
47	M6x40 DIN 912	Screw	2	109	203 4047	Upright post welded, R	1
48	533 4073	Track stopper	2	110	403 4127	Cable, set (incl. 3)	1
49	M6 DIN 6798 I	Star washer	2	111	203 4048	Upright post welded, L	1
51	653 4055	Nut (incl. 50)	1	*112	M8x55 ISO 7380	Dome head bolt	1
52	343 4016	Lift motor shaft	1	113	173 4083	Handle bar cover, L pair	1
53	813 4024	Lift motor, 230V (50-52, 54)	1	115	2,9x15 DIN 7981	Screw	6
-	813 4028	Lift motor, 110V (50-52, 54)	1	116	203 4049	Horizontal bar (incl. 128)	1
54	2 DIN 11024	Pin	1	118	403 4099	Safety key	1
55	403 4110	Power board, 230V	1	121	3,5x15 DIN 7982	Screw	8
-	403 4123	Power board, 110V	1	122	M3x6 DIN 7985	Screw	4
56	643 4006	Off power spring	1	123	M3 DIN 137 B	Spring washer	4
57	523 4046	Off power sleeve	1	124	403 4116	EMI filter, EUR (incl. 125)	1
58	503 4048	Off power bracket	1	126	M4 DIN 6798 I	Star washer	2
60	403 4128	Micro switch (incl.59, 61, 63)	1	127	813 4025	Choke, EUR	1
62	M4x10 DIN 7985	Screw	2	128	213 4019	Handle grip horizontal	1
64	M5x10 DIN 7985	Screw	6	129	233 4030	Membrane	1
65	M5 DIN 127	Spring washer	2	130	173 4076	Lower cover	1
66	403 4106	Sensor cable	1	*	403 4104	Power cable, EUR	1
67	813 4026	Motor, 230V	1	*	403 4125	Power cable, USA	1
-	813 4027	Motor, 110V	1	*	403 4126	Power cable, GB	1
68	503 4046	Motor bracket	1	*	423 4093	Lable set	1
				*	553 4020	Assembly kit (incl *)	1
				-	583 4028	Owner's manual	1

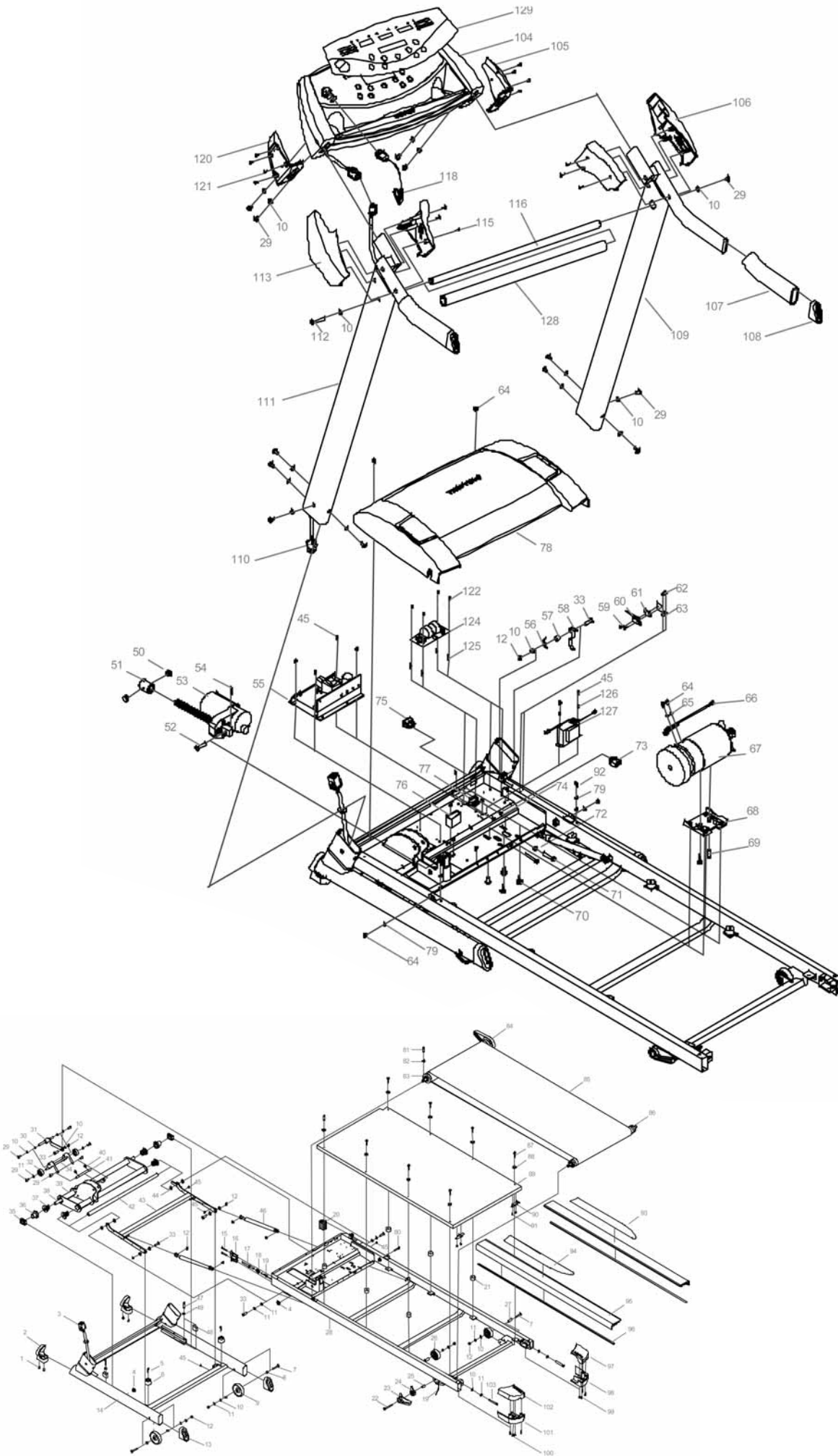

PROFILES

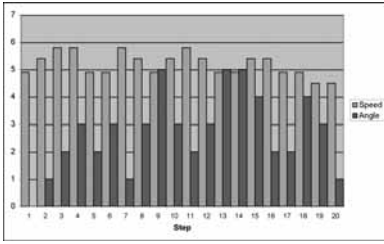

Profile 1: Hillwalk
100 %:
max. speed 5,8 km/h
max. angle 5,0 %

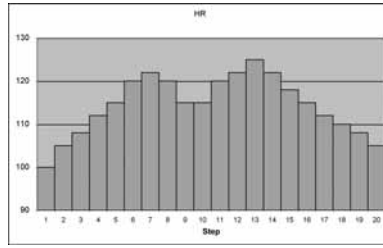

Profile 5: Fatburner 1
100 %:
max. HR 125 bpm

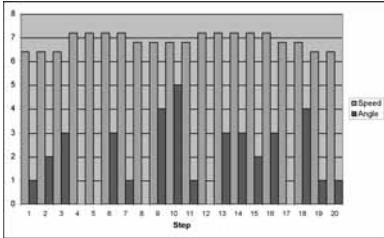

Profile 2: Hill jog
100 %:
max. speed 7,2 km/h
max. angle 5,0 %

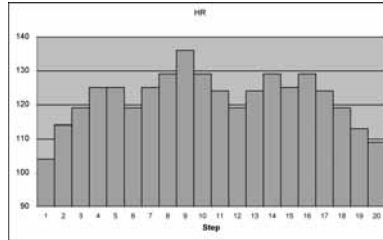

Profile 6: Fatburner 2
100 %:
max. HR 136 bpm

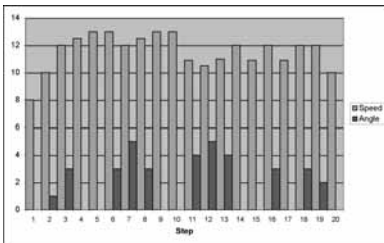

Profile 3: Hill run
100 %:
max. speed 13,0 km/h
max. angle 5,0 %

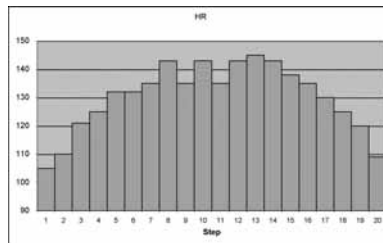

Profile 7: Cardio
100 %:
max. HR 145 bpm

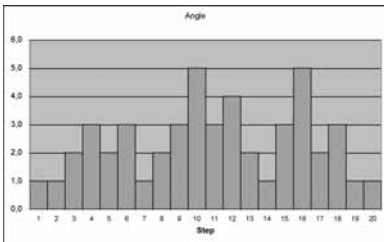

Profile 4: Rolling hills
100 %:
max. angle 5,0 %

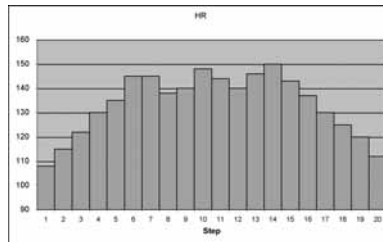

Profile 8: Fit
100 %:
max. HR 150 bpm





TUNTURI[®]
THE MOTOR – *it's you.*

TUNTURI OY LTD

P.O.BOX 750, FIN-20361
Turku, Finland
Tel. +358 (0)2 513 31
Fax +358 (0)2 513 3323
www.tunturi.com

5834017 B

Free Manuals Download Website

<http://myh66.com>

<http://usermanuals.us>

<http://www.somanuals.com>

<http://www.4manuals.cc>

<http://www.manual-lib.com>

<http://www.404manual.com>

<http://www.luxmanual.com>

<http://aubethermostatmanual.com>

Golf course search by state

<http://golfingnear.com>

Email search by domain

<http://emailbydomain.com>

Auto manuals search

<http://auto.somanuals.com>

TV manuals search

<http://tv.somanuals.com>