

REFRIGERATOR MANUFACTURER
Turbo air

1250 Victoria Street
CARSON, CA 90746
TEL : 310-900-1000
FAX : 310-900-1077
Toll Free : 1-800-627-0032
(U.S.A and Canada)
<http://www.turboairinc.com>

Turbo air Speeds UP the Pace of Innovation

REFRIGERATOR MANUFACTURER
Turbo air

COMMERCIAL REFRIGERATOR **Installation and Operation Manual**

Please read this manual completely before attempting to install or operate this equipment!

SAK-50*

SAK-60*

SAK-70*

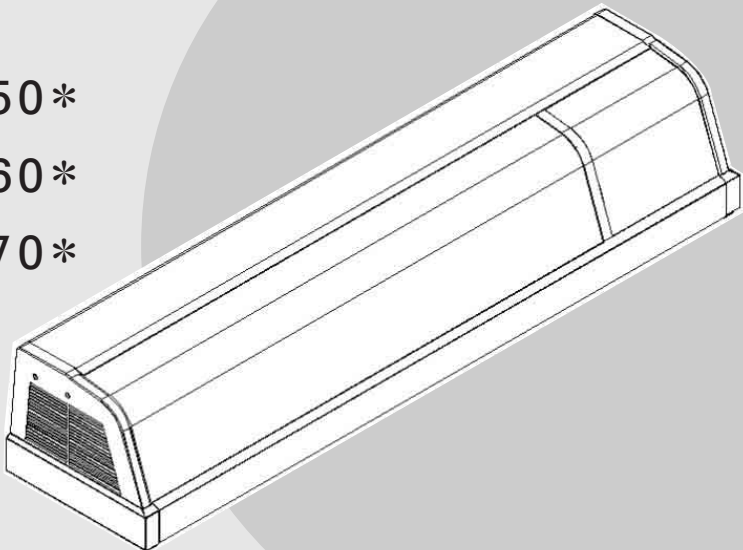

CONTENTS

INTRODUCTION	1
SPECIFICATION	3
INSTALLATION INSTRUCTIONS	3~4
Inspection for damage	
Location of Display	
Leveling of Display	
OPERATING INSTRUCTIONS	5
Power input/output	
Thermometer	
How to place product	
MAINTENANCE & CLEANING	6~8
Interior/Exterior cleaning	
Drain pipe cleaning	
Condenser coil	
TROUBLE SHOOTING	8
Display not working	
Display case warm	
WIRING DIAGRAM	9
WARRANTY STATEMENT	9~13

INTRODUCTION

This owner's manual has important information. Please read the entire manual before installing your new Turbo Air Open Display Merchandiser. After reading manual if you have any questions, please feel free to call:

"R" or "L" on the model name designates the location of the compressor in the unit.

**CUSTOMER SERVICE DEPARTMENT
TURBO AIR
1250 VICTORIA ST.
CARSON, CA 90746
1-800-381-7770**

Please write down model and serial number for making any reference to this unit.

MODEL NUMBER _____

SERIAL NUMBER _____

WARNING!

Failure to read this manual completely can result in personal injury or damage to the unit. Keep manual in a safe place to refer to in the future.

Display should be on dedicated outlet for proper operation.

This equipment is for the storage and display of packaged foods only

Do not put above 120mm height

Thank you for purchasing Turbo Air!

SPECIFICATION

Model	SAK-50*	SAK-60*	SAK-70*
Dimension (W×D×H)in	48.8×14.2×11.5	60.3×14.2×11.5	71.8×14.2×11.5
Electricity	120V/1Ph/60Hz		
Power Input	3A	3A	3A
Compressor	SD152C-L1U2		
Refrigerant	R-134a		
Weight of Case	76.06 lbs	87.08 lbs	98.01 lbs

INSTALLATION INSTRUCTIONS

INSPECTION FOR DAMAGE

Customer is responsible for checking for damage. First inspect crate as soon as it arrives. Prior to signing if crate is damaged make sure you note that on bill of lading. If after uncrating there is concealed damage and crate was in good condition you must call Customer Service at Turbo Air. Concealed damage must be reported within 24 hours of receiving unit. Bill of lading will be requested faxed to claim department. Pictures may be requested of unit and crating.

LOCATION OF DISPLAY CASE MERCHANDISER

Display is designed to be in an ambient 75 degrees Fahrenheit (dry bulb) or colder and 55 percent relative humidity. If unit is installed in a warm ambient Display will not cool effectively. Move the display to the final location before removing shipping skid. Allow 3 inches from back of Display to wall. Condenser is located in beside of Display. Do not block inlet /outlet.

LEVELING OF DISPLAY CASE MERCHANDISER

- a. Display case should be installed on well leveled table or flatted location.
- b. If unit is not leveled, drainage of water will not drain properly. Leveling legs can be adjusted accordingly

OPERATING INSTRUCTIONS

POWER INPUT/OUTPUT

- a. After installing unit and all electrical to the Display, Display is ready to start up.
- b. Input is controlled by pushing the button,

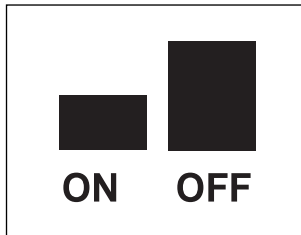

iii Approx 30min interval is needed to reactivate display case after power off.

THERMOMETER:

Thermometer showing temperature is located on opposite side of machine room,

NOTE:

Before placing products to Display wait for unit to reach desired temperature,

Do not place hot product in unit,

HOW TO PLACE PRODUCT:

Do not overload product on shelves,

MAINTENANCE & CLEANING

INTERIOR/EXTERIOR CLEANING

- a. Always before cleaning Display, Remove products and unit should be turned off at power switch
- b. Do not wet electrical components.
- c. Do not use water jet to clean the exterior.

DRAIN PIPE CLEANING

- a. Either mix 0,26 gal(1liter) of water with 0,13fl.Oz(3,7ml) of 5,25% sodium hypochlorite in a suitable container.
- b. Join the drain hose and turn up the end of hose above display case
- c. Slowly pour the sanitizing solution into the drain inside of display and full it up to the end of hose.
- d. Wait for 5 minutes, and turn down the end of the drain hose to drain the solution.

DISPLAY CASE SHOULD BE CLEANED THOROUGHLY BEFORE FIRST USE.

- a. Do not clean with harsh detergents. Use a mild soap
- b. Remove all products.
- c. Remove bottom trays.
- d. Clean interior with warm water and mild detergent.
- e. Wipe with soft cloth soaked in warm water. Do not leave residue of soap.

CONDENSER COIL

! How to remove Louver

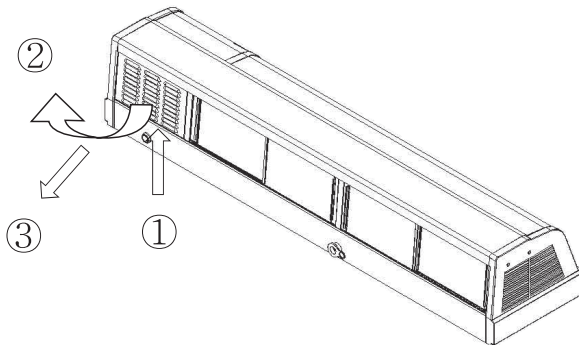

1. Disconnect the electrical power to the unit
2. Lift up the Louver to release the Louver from the body.(①)

3. Pull the Louver toward you, (②)
4. Pull on the downward, (③)
5. Brush the dirt, lint, etc from the finned condenser coil.
6. When finished, Louver installed by reverse way of removing
7. Reconnect the electrical power to the unit.
8. Condenser should be cleaned every 1 months or as needed.

EVAPORATOR COIL

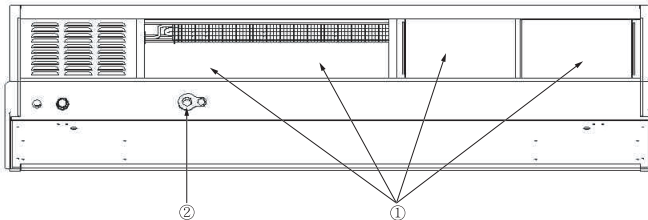

1. Remove the glass door and Bottom shelf, (①)
2. Join the drain hose, (②)
3. Sweep evaporator pins with warm water and brush.
4. Clean up with soft cloth the evaporator pins.
5. When finished cleaning off properly, remove the drain hose.
6. Reconnect the Glass door and Bottom shelf.

TROUBLE SHOOTING

For any problems with Display, please refer to following check list. If still having a problem or need to ask a question please call Customer service at 1-800-381-7770.

DISPLAY NOT WORKING

- a. Check power going to unit.
- b. Check power switch is on.

DISPLAY CASE WARM

- a. Check condenser to see if clean.

WIRING DIAGRAM

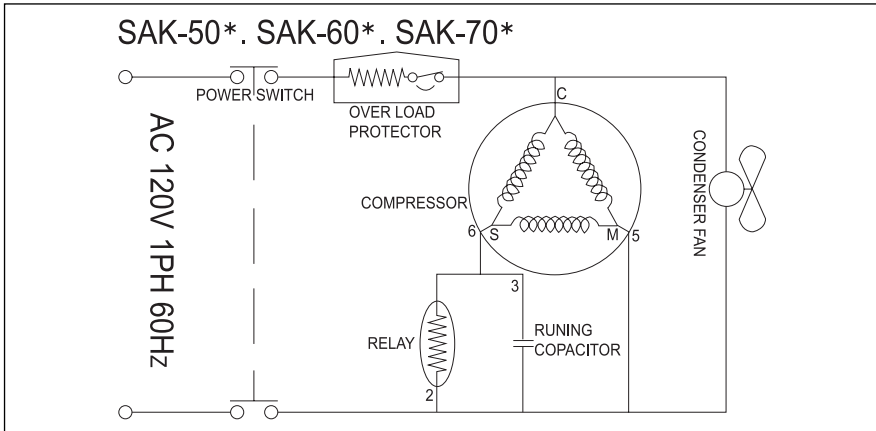

WARRANTY STATEMENT

Warranty claims

All claims for labor or parts must be made directly through Turbo Air.

All claims should include: model number of the unit, the serial number of the cabinet, proof of purchase, date of installation, and all pertinent information supporting the alleged defect.

In case of compressor replacement under warranty, either compressor or compressor tag must be returned to Turbo Air along with above listed information.

Failure to comply with warranty policies will result in voiding claims.

One Year Parts & Labor Warranty

Turbo Air warrants all new refrigerated components, the cabinet and all parts, to be free from defects in materials or workmanship, under normal and proper use and maintenance service as specified by Turbo Air and upon proper installation and start-up in accordance with the instruction packet supplied with each Turbo Air unit. Turbo Air's obligation under this warranty is limited to a period of one(1) year from the date of original installation or 15 months after shipment date from Turbo Air, whichever occurs first.

Any part, covered under this warranty, that are by Turbo Air to have been defective within one(1) year of original installation or fifteen(15) months after shipment date from manufacturer, whichever occurs first, is limited to the repair or replacement, including labor charges, of defective parts or assemblies. The labor warranty shall include standard straight time labor charges only and reasonable travel time, as determined by Turbo Air.

Additional Four Year Compressor Warranty.

In addition to the one(1) year warranty stated above, Turbo Air warrants its hermetically sealed compressor to be free from defects in both material and workmanship under normal and proper use and maintenance service for a period of four (4) additional years from the date of original installation, but not to exceed five (5) years and three (3) months after shipment from the manufacturer.

Compressor determined by Turbo Air to have been defective within this extended period will, at Turbo Air's discretion, be either repaired or replaced with a compressor or compressor parts of similar design and capacity.

The four (4) year extended compressor warranty applies only to hermetically sealed parts of the compressor and does not apply to any other parts or components, including, but not limited to, cabinet, paint finish, temperature control, refrigerant,

metering device, m driers, motor starting equipment, fan assembly or and other electrical components, etcetera.

404A / R134A Compressor warranty

The four-year compressor warranty detailed above will be void if the following Procedure is not carefully adhered to:

1. This system contains R404A or R134A refrigerant and polyol ester lubricant. The polyol ester lubricant has rapid moisture absorbing qualities.
2. Drier replacement is very important and must be changed when a system is opened for servicing. A 620 dopper drier or better is highly recommended.
3. Micron level vacuums must be achieved to insure low moisture levels in the system. 500 microns or lower must be obtained.
4. When compressor is grounded, suction filter drier and 620 drier or better must be replaced.
5. Compressor must be obtained through Turbo Air, unless otherwise specified in writing, through Turbo Air's warranty department.

What is not covered by this warranty

Turbo Air's sole obligation under this warranty is limited to either repair or replacement of parts, subject to the additional limitations below. This warranty neither assumes nor authorizes any person to assume obligations other than those expressly covered by this warranty.

NO CONSEQUENTIAL DAMAGES. TURBO AIR IS NOT RESPONSIBLE FOR ECONOMIC LOSS; PROFIT LOSS; OR SPECIAL, INDIRECT, OR CONSEQUENTIAL DAMAGES, INCLUDING WITHOUT LIMITATION, LOSSES, OR DAMAGES ARISING FROM FOOD OR PRODUCT SPOILAGE REGARDLESS OF WHETHER OR NOT THEY

RESULT FROM REFRIGERATION FAILURE, WARRANTY IS NOT TRANSFERABLE. This warranty is not assignable and applies only in favor of the original purchaser / user to whom delivered. ANY SUCH ASSIGNMENT OR TRANSFER SHALL VOID THE WARRANTIES HEREIN AND SHALL VOID ALL WARRANTIES, EXPRESS OR IMPLIED, INCLUDING ANY WARRANTY OF MERCHANTABILITY OR LABOR COVERAGE FOR COMPONENT FAILURE OR OTHER THE WARRANTY PACKET PROVIDED WITH THE UNIT.

ALTERATION, NEGLIGENCE, ABUSE, MISUSE, ACCIDENT, DAMAGE DURING TRANSIT OR INSTALLATION, FIRE, FLOOD, ACTS OF GOD, Turbo Air is not responsible for the repair or replacement of any parts that Turbo Air determines have been subjected after the date of manufacture to alteration, neglect, abuse, misuse, accident, damage during transit or installation, fire, flood, or act of GOD.

IMPROPER ELECTRICAL CONNECTIONS. TURBO AIR IS NOT RESPONSIBLE FOR THE REPAIR OR REPLACEMENT OF FAILED OR DAMAGED COMPONENTS RESULTING FROM ELECTRICAL POWER FAILURE, THE USE OF EXTENSION CORDS, LOW VOLTAGE, OR VOLTAGE DROPS TO THE UNIT. NO IMPLIED WARRANTY OF MERCHANTABILITY OR FITNESS FOR A PARTICULAR PURPOSE: THERE ARE NO OTHER WARRANTIES, EXPRESSED, IMPLIED OR STATUTORY, EXCEPT THE ONE(1) YEAR PARTS & LABOR WARRANTY AND THE ADDITIONAL FOUR(4) YEAR COMPRESSOR WARRANTY AS DESCRIBED ABOVE. THESE WARRANTIES ARE EXCLUSIVE AND IN LIEU OF ALL OTHER WARRANTIES, INCLUDING IMPLIED WARRANTY AND MERCHANTABILITY OR FITNESS FOR A PARTICULAR PURPOSE. THERE ARE NO WARRANTIES, WHICH EXTEND BEYOND THE DESCRIPTION ON THE FACE HEREOF.

Outside U.S. and Canada: This warranty does not apply to, and Turbo Air is not

responsible for, any warranty claims made on products sold or used outside the continent of the United States and Canada, failure to clean and/ or maintain product as set forth in the warranty packet provided with the unit

Free Manuals Download Website

<http://myh66.com>

<http://usermanuals.us>

<http://www.somanuals.com>

<http://www.4manuals.cc>

<http://www.manual-lib.com>

<http://www.404manual.com>

<http://www.luxmanual.com>

<http://aubethermostatmanual.com>

Golf course search by state

<http://golfingnear.com>

Email search by domain

<http://emailbydomain.com>

Auto manuals search

<http://auto.somanuals.com>

TV manuals search

<http://tv.somanuals.com>