



## **NuQ SERIES**

### **USER MANUAL**

**Turbosound Ltd.  
Star Road, Partridge Green  
West Sussex RH13 8RY England**

**Tel: +44 (0)1403 711447  
Fax: +44 (0)1403 710155  
[www.turbosound.com](http://www.turbosound.com)**

Issue 1.0 July 2007  
Copyright © 2007 Turbosound Ltd.

## Contents

<b>Introduction</b> .....	<b>4</b>
Thanks .....	4
Unpacking .....	4
<b>Product Range Summary</b> .....	<b>5</b>
General Features .....	5
General Features for Two-Way Enclosures .....	6
Model Information .....	7
NuQ-8 .....	7
NuQ-10 .....	7
NuQ-12 .....	8
NuQ-15 .....	8
B15 .....	9
B18 .....	9
NuQ-8DP.....	10
NuQ-10DP.....	10
NuQ-12DP.....	11
NuQ-15DP.....	11
B15DP .....	12
B18DP .....	12
<b>System Requirements</b> .....	<b>13</b>
Passive loudspeakers and switchable loudspeakers used in passive mode.....	13
<b>Amplifier Considerations</b> .....	<b>14</b>
Self-powered Loudspeakers.....	15
<b>Loudspeaker connections</b> .....	<b>16</b>
Passive systems .....	16
Bi-amped systems.....	16
Cable Recommendations .....	17
<b>Networking Capability</b> .....	<b>18</b>
Computer system requirements .....	18
Hardware requirements.....	18
TurboDrive™ Quick Reference Setup .....	19
<b>Loudspeaker Placement</b> .....	<b>21</b>
Choosing the best location.....	21
Dispersion .....	21
Calculating the sound pressure level at a known distance from the PA .....	22
Equalisation .....	22
<b>System Configurations</b> .....	<b>23</b>
System1 – Basic Stereo Passive setup.....	23
System 2 – Stereo Passive setup with Bass Units and Active Crossover.....	24
System 3 – Stereo Bi-amped setup with Active Crossover.....	25

---

System 4 – Stereo Bi-amped setup with Sub-bass units and Active Crossover .....	26
<b>Loudspeaker Management Systems .....</b>	<b>27</b>
Turbosound LMS series loudspeaker management systems.....	27
LMS-D24/6 Quick Reference Set Up .....	29
Starting up .....	29
About Presets.....	29
Preset Recall.....	30
Creating a user defined crossover .....	30
Store button .....	30
LMS-D24/D26 Audio Connections .....	31
Audio Input connectors.....	31
Audio Output connectors .....	31
Presets and Secure mode.....	31
<b>Flying &amp; Lifting / Rigging.....</b>	<b>32</b>
Hardware Compatibility .....	33
Speaker Pole and Tripod Stand Mounting .....	33
Use with Flying Yokes.....	33
Truss Mounting .....	33
Wall Mounting .....	34
Ceiling Mounting .....	35
Small Loudspeaker Arrays .....	35
Horizontal Rigging.....	35
Small Vertical Array .....	36
Using the T-bar .....	36
Flying Single Enclosures .....	37
Use of Thread Locking Compounds.....	39
<b>Servicing Information.....</b>	<b>40</b>
Removal of the low frequency driver – B15 front loaded bass enclosure .....	40
Removal of the low frequency driver – B18 bandpass bass enclosure .....	41
Removal of the HF compression driver and LF driver – two-way cabinets.....	42
<b>About EASE Data .....</b>	<b>43</b>
Overview .....	43
Use of Turbosound EASE data .....	44
<b>Technical Specifications.....</b>	<b>45</b>
Non-Powered Enclosures .....	45
Self-powered Enclosures.....	46
<b>Spare Parts List.....</b>	<b>47</b>
<b>Warranty.....</b>	<b>48</b>
<b>Notes .....</b>	<b>50</b>

## **Introduction**

Congratulations, you have just purchased a professional loudspeaker product from the NuQ series of professional portable loudspeakers, designed to give you the best in audio quality and many years of reliable, trouble free operation. It offers excellent pattern control, superior audio quality, self-powered options, networking capability, integral rigging hardware options, full technical documentation including EASE data, and a comprehensive warranty against manufacturing defects. Please read through this manual carefully before you attempt to operate the loudspeaker system. It contains valuable information enabling you to quickly and easily connect the loudspeakers to your amplifiers, important system and set-up checks together with positioning and mounting instructions.

## **Thanks**

Thank you for choosing a TURBOSOUND NuQ series loudspeaker product for your application. Please spare a little time to read the contents of this manual, so that you obtain the best possible performance from this unit.

All TURBOSOUND products are carefully engineered for world class performance and reliability.

If you would like further information about this or any other TURBOSOUND product, please contact us. Detailed product information is available on our web site at [www.turbosound.com](http://www.turbosound.com)

We look forward to helping you in the near future.

## **Unpacking**

After unpacking the unit please check carefully for damage. If damage is found, please notify the carrier concerned at once. You, the consignee, must instigate any claim. Please retain all packaging in case of future re-shipment.

## **Product Range Summary**

### **General Features**

NuQ series loudspeakers are designed for use in a wide variety of professional portable sound reinforcement applications. These advanced features ensure that they will continue to deliver consistently high quality audio performance.

- Digitally self-powered product options provide a fully integrated, convenient plug-and-play sound reinforcement solution for professional applications.
- NuQ systems are fully networkable over a BVNet network, giving real time control and monitoring of operating parameters
- The enclosures are supplied with a durable black or white semi-matt textured paint finish as standard.
- Powder-coated perforated steel mesh grilles backed with reticulated foam protect the drive units from damage and provide an unobtrusive and aesthetically pleasing appearance.
- High quality neodymium magnets are used throughout to reduce overall weight. Cast-frame low frequency drivers give the combined benefits of high strength and low weight.
- Speakon NL4MP connectors are used on non-powered models for input and loop-through / parallel connections to additional NuQ series speakers.
- Class D amplifiers use 96kHz sample rates for pristine audio quality, and are better than 90% efficient

### General Features for Two-Way Enclosures

- High-grade neodymium-magnet speaker components are matched with an internal passive crossover to ensure a seamless transition between the high frequency and low frequency drivers.
- 12" and 15" models are switchable active / passive via a rear panel toggle switch to enable fully bi-amplified operation.
- The 1" high frequency compression driver used in the NuQ-8 and NuQ-10 is a proprietary design based on the award-winning Aspect® series HF driver.
- Cabinets are constructed from high quality pre-formed birch plywood; rebated, glued and screwed together for maximum strength and rigidity. This construction method entirely eliminates four cabinet joints and reduces overall weight.
- The symmetrical quasi-trapezoidal cabinet shape with 45° side angle is designed to enable reversible low profile wedge monitoring applications
- Multiple rigging points enable a wide variety of installation methods: on speaker stands and poles; with Turbosound yokes and swivel brackets; with OmniMount™ hardware and specifically created Turbosound wall brackets. The enclosures are also fitted with internal M10 threaded rigging points on the top, sides, bottom and rear, that allow single cabinets to be suspended and angled in fixed installations.
- The rigging points on the bottom of the cabinets enable them to be hung upside down in order to position the HF driver closer to the audience.
- NuQ Series two-way enclosures are designed to give good pattern control down to crossover frequency, and are fully supported with EASE polar data (available to download from the Turbosound website at [www.turbosound.com](http://www.turbosound.com)). This enables accurate and predictable results when specifying sound systems in a given venue.

## Model Information

### NuQ-8

The NuQ-8 is a compact trapezoidal passive two-way loudspeaker enclosure designed for use in mobile speech and music sound reinforcement applications as well as a range of fixed installations. It combines a neodymium 8" LF driver with a 1" HF compression driver on a rotatable 100° x 60° high frequency waveguide with a passive crossover network. Its symmetrical cabinet shape allows it to be used as a low profile monitor wedge. Two Speakon NL4 connectors provide input and link out connections to additional NuQ series loudspeakers.



The cabinet is fitted with a pole mount socket and multiple internal rigging points which enable it to be used with poles and speaker stands, yokes and swivel brackets, wall brackets, and OmniMount™ series 20.5 brackets.



### NuQ-10

The NuQ-10 is a compact trapezoidal passive two-way loudspeaker enclosure designed for use in mobile speech and music sound reinforcement applications as well as a range of fixed installations. It combines a neodymium 10" LF driver with a 1" HF compression driver on a rotatable 100° x 60° high frequency waveguide with a passive crossover network. Its symmetrical cabinet shape allows it to be used as a low profile monitor wedge. Two Speakon NL4 connectors provide input and link out connections to additional NuQ series loudspeakers.

The cabinet is fitted with a pole mount socket and multiple internal rigging points which enable it to be used with poles and speaker stands, yokes and swivel brackets, wall brackets, and OmniMount™ series 60 brackets.

### **NuQ-12**

The NuQ-12 is a trapezoidal switchable active/passive two-way loudspeaker enclosure designed for use in mobile speech and music sound reinforcement applications as well as a range of fixed installations. It combines a neodymium 12" LF driver with a 1.4" HF compression driver on a rotatable 80° x 50° high frequency waveguide with a passive crossover network, switchable to fully bi-amplified operation via a rear panel switch. Its symmetrical cabinet shape allows it to be used as a low profile monitor wedge. Two Speakon NL4 connectors provide input and link out connections to additional NuQ series loudspeakers.



The cabinet is fitted with a pole mount socket and multiple internal rigging points which enable it to be used with poles and speaker stands, yokes and swivel brackets, wall brackets, and OmniMount™ series 60 brackets.

### **NuQ-15**

The NuQ-15 is a trapezoidal switchable active/passive two-way loudspeaker enclosure designed for use in mobile speech and music sound reinforcement applications as well as a range of fixed installations. It combines a neodymium 15" LF driver with a 1.4" HF compression driver on a rotatable 80° x 50° high frequency waveguide with a passive crossover network, switchable to fully bi-amplified operation via a rear panel switch. Its symmetrical cabinet shape allows it to be used as a low profile monitor wedge. Two Speakon NL4 connectors provide input and link out connections to additional NuQ series loudspeakers.



The cabinet is fitted with a pole mount socket and multiple internal rigging points which enable it to be used with poles and speaker stands, yokes and swivel brackets, wall brackets, and OmniMount™ series 120 brackets.



### **B15**

The B15 is a front-loaded, high efficiency low frequency loudspeaker designed to give bass and sub-bass reinforcement to NuQ-8 and NuQ-10 two-way models. It will normally form part of a two-way active system in conjunction with a Turbosound LMS series loudspeaker management system.



It consists of a single 15" reflex-loaded low frequency driver in an optimally tuned 18mm (3/4") birch plywood enclosure with built-in pole mount socket and moulded corner protectors. Two Speakon NL4 connectors provide input and link out connections.

### **B18**

The B18 is a high efficiency bandpass subwoofer designed to give sub-bass reinforcement to the NuQ-12 and NuQ-15 two-way models. It will normally be used as part of a two-way or three-way active system in conjunction with a Turbosound LMS series loudspeaker management system.



It consists of a single 18" bandpass-loaded low frequency driver in an optimally tuned 18mm (3/4") birch plywood enclosure with pole mount socket constructed from with a built-in pole mount socket and moulded corner protectors. Two Speakon NL4 connectors provide input and link out connections.

### **NuQ-8DP**

The NuQ-8DP is a compact, trapezoidal, digitally self-powered networkable two-way loudspeaker enclosure incorporating integrated Class D amplifier and control electronics module. It combines an 8" LF driver with a 1" HF compression driver on a rotatable 100° x 60° high frequency waveguide. Its symmetrical cabinet shape allows it to be used as a low profile monitor wedge. The amplifier module provides input and link XLRs, RJ45 network connectors, low frequency contour, power switch and status LED's. The power supply is auto-sensing, enabling connection to mains supplies ranging from 100 volts to 240 volts AC.



The cabinet is fitted with a pole mount socket which enables it to be used with poles and speaker stands.

### **NuQ-10DP**

The NuQ-10DP is a trapezoidal, digitally self-powered networkable two-way loudspeaker enclosure incorporating an integrated Class D amplifier and control electronics module. It combines a 10" LF driver with a 1" HF compression driver on a rotatable 100° x 60° high frequency waveguide. Its symmetrical cabinet shape allows it to be used as a low profile monitor wedge. The amplifier module provides input and link XLRs, RJ45 network connectors, low frequency contour, power switch and status LED's. The power supply is auto-sensing, enabling connection to mains supplies ranging from 100 volts to 240 volts AC.



The cabinet is fitted with a pole mount socket which enables it to be used with poles and speaker stands.

### **NuQ-12DP**

The NuQ-12DP is a trapezoidal, digitally self-powered networkable two-way loudspeaker enclosure incorporating an integrated Class D amplifier and control electronics module. It combines a 12" LF driver with a 1.4" HF compression driver on a rotatable 100° x 60° high frequency waveguide. Its symmetrical cabinet shape allows it to be used as a low profile monitor wedge. The amplifier module provides input and link XLRs, RJ45 network connectors, low frequency contour, power switch and status LED's. The power supply is auto-sensing, enabling connection to mains supplies ranging from 100 volts to 240 volts AC.

The cabinet is fitted with a pole mount socket which enables it to be used with poles and speaker stands.



### **NuQ-15DP**

The NuQ-15DP is a trapezoidal, digitally self-powered networkable two-way loudspeaker enclosure incorporating an integrated Class D amplifier module and control electronics. Amplifier module includes input and link XLRs, RJ485 network connectors, low frequency contour, power switch and status LED's. The power supply is auto-sensing, enabling connection to mains supplies ranging from 100 volts to 240 volts AC.

The cabinet is fitted with a pole mount socket which enables it to be used with poles and speaker stands.



### **B15DP**

The B15DP is a self-powered front-loaded, high efficiency low frequency loudspeaker designed to give bass and sub-bass reinforcement to the NuQ-8DP and NuQ-10DP two-way models.



It consists of one 15" reflex-loaded low frequency driver in an optimally tuned enclosure with pole mount socket and moulded corner mouldings constructed from 18mm (3/4") birch plywood and incorporating an integrated Class D amplifier and control electronics module. The rear panel carries input and link XLRs, RJ485 network connectors, low frequency contour, power switch and status LED's.

### **B18DP**

The B18DP is a self-powered high efficiency bandpass subwoofer designed to give sub-bass reinforcement to the NuQ-12DP and NuQ-15DP two-way models.



It consists of one 18" bandpass-loaded low frequency driver in an optimally tuned enclosure with pole mount socket and moulded corner protectors constructed from 18mm (3/4") birch plywood and incorporating an integrated Class D amplifier and control electronics module. The rear panel carries input and link XLRs, RJ485 network connectors, low frequency contour, power switch and status LED's.

## **System Requirements**

### **Passive loudspeakers and switchable loudspeakers used in passive mode**

NuQ series passive loudspeaker enclosures require only one amplifier channel for correct operation, the frequency splitting between the low frequency driver and the high frequency driver being accomplished by the internal passive crossover network built into each enclosure.

If subwoofer enclosures are used as part of a bi-amplified system in conjunction with NuQ series 2-way enclosures to extend low frequency response, additional amplifier channels and external electronic crossovers will be required. The Turbosound LMS-D6 and LMS-4 digital loudspeaker management systems are recommended for this purpose, as well as other professional quality digital controllers.

Switchable active/passive loudspeaker enclosures when used in bi-amped mode require the use of one amplifier channel per frequency band for correct operation. Frequency splitting between the low frequency driver and the high frequency driver is accomplished by a Turbosound LMS-D2X digital loudspeaker management system.

Dedicated subwoofer enclosures require an additional amplifier channel when used as part of an extended frequency system. Frequency splitting between it and a NuQ series mid-high enclosure is accomplished by an external crossover. Turbosound LMS series digital loudspeaker management systems are recommended for this purpose.

## **Amplifier Considerations**

Turbosound NuQ series loudspeaker enclosures should be driven by high quality power amplifiers designed for true professional use. Such amplifiers will have balanced inputs, DC and RF fault protection, and well designed cooling systems for reliability.

The 'program' power, listed in the loudspeaker's technical specification, is the best guide to the size of amplifier required for general purpose applications. The amplifier should be capable of delivering long term broadband power equal to the loudspeaker's program power rating at the loudspeaker's stated nominal impedance. This approach allows sufficient headroom to generate good dynamic range.

### **RECOMMENDED AMPLIFIER POWER RATINGS:**

The amplifier's rated continuous power output (20Hz – 20kHz, per channel) should be equal to the program power handling of the loudspeaker at its nominal impedance.

It should be understood that overdriving an insufficiently powered amplifier is more likely to cause loudspeaker damage – the total energy in a heavily clipped signal is far higher than in an unclipped signal – than operating a more powerful amplifier within its ratings. In general, the more powerful the amplifier the better it will sound, provided that it is not also driven into sustained clipping.

All the equipment in the system before the system controller should be set up for 0dBV (775mV) maximum output. One controller can be used to feed several amplifiers as long as all the amplifiers are the same (or have the same gain ratings). More than one controller may be required if the amplifiers are of different gain or type. Please contact your dealer if you require help in this area.

Turbosound recommends the T-series amplifiers for use with the NuQ series system. For further information on T-series power amplifiers please visit the product showroom section of our website at [www.turbosound.com](http://www.turbosound.com)

### **Self-powered Loudspeakers**

The Class D amplifier modules fitted to the NuQ-8DP and NuQ-10DP self-powered loudspeakers comprise one amplifier channel rated at 500 watts continuous, powering both low frequency and high frequency drivers through a passive crossover network.

The Class D amplifier modules fitted to the NuQ-12DP and NuQ-15DP self-powered loudspeakers comprise two amplifier channels rated at 800 watts continuous: one channel to power the low frequency driver (LF) plus another channel to power the high frequency (HF) driver; plus an active crossover to split the signal and feed it to the appropriate amplifier and driver section. Additional features such as limiting, digital time alignment and driver EQ are carried out in the on-board DSP.

The Class D amplifier modules fitted to the B15DP and B18DP self-powered subwoofers use the two-channel amplifier bridged to provide 1600 watts continuous.

Self-powered NuQ series products do not require the use of external amplifiers or crossover/limiters.

Additional units may be daisy-chained together simply by linking the signal connections through the input / link XLR connectors. In this way exact coverage of an event or permanent installation may be achieved using a number of digitally powered loudspeakers. It is however necessary to route individual power cords to each enclosure as it is not possible to daisy-chain AC connections through the power connectors.

## Loudspeaker connections

### Passive systems

NuQ series passive loudspeakers are equipped with a recessed connector panel housing two Neutrik Speakon NL4MP connectors wired in parallel and serving as both input and loop out connections to additional NuQ series loudspeakers. The pin connections for the NuQ-8 and NuQ-10—and the NuQ-12 and NuQ-15 when used in passive mode—adhere to the standard professional audio loudspeaker wiring convention, which is pin 1+ positive and pin 1- negative as shown below. Pins 2+ and 2- are not connected.

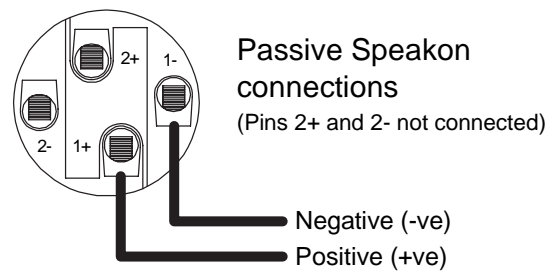

### Bi-amped systems

Pin connections for the NuQ-12 and NuQ-15 when used in bi-amped mode are as shown below. Pin 1+ is LF positive, pin 1- is LF negative, pin 2+ is HF positive, pin 2- is HF negative. Move the rear panel switch from 'passive' to 'active' for bi-amp operation before attempting to operate the loudspeaker.

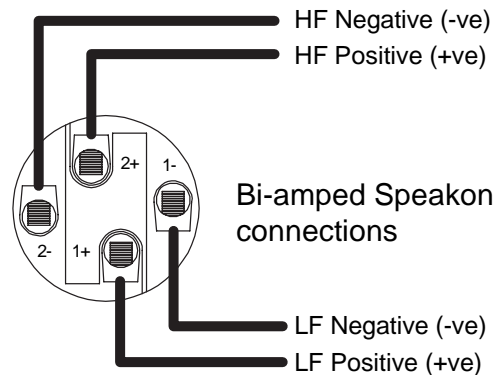

Note that looping out to additional enclosures has the effect of reducing the load impedance on the amplifier. For example, two 8 ohm cabinets in parallel give a combined



total impedance of 4 ohms. Never connect loudspeakers whose total combined impedance is lower than the amplifier's recommended minimum load impedance. Do not use the loop-out connection to connect other types of loudspeaker, especially when their impedance is not known, as permanent damage could result!

Please take care if XLRs, binding posts, or other dual connector systems, are used at the amplifier end of the loudspeaker cables (jack plugs/sockets should not be used) where there is a possibility of the cables being reversed. It is highly recommended that Neutrik Speakon or other heavy duty non-reversible connectors are used.

### Cable Recommendations

Heavy duty loudspeaker cable should always be used, with a minimum wire size of 12 gauge (1.5mm<sup>2</sup>), and preferably 10 gauge (2.5mm<sup>2</sup>) for longer runs, keeping the run as short as possible. This helps to avoid wasting amplifier power in the resistance of the cable. High cable resistance also lowers the damping factor of the amplifier which affects its ability to control loudspeaker cone movement.

Losses due to undersized cable and long runs are clearly illustrated in the table below. Please use this table to determine the most suitable cable size and maximum run for your particular application.

Nominal Cable Area (mm <sup>2</sup> )	Cable Length (m)	Cable Resistance (W)	Voltage Drop (%) 8 ohms		Sensitivity Loss (dB)	
			8W	4W	8W	4W
1.5	5	0.07	0.8	1.6	-0.1	-0.1
	10	0.13	1.6	3.2	-0.1	-0.3
	25	0.33	4.0	7.7	-0.4	-0.7
	50	0.67	7.7	14.3	-0.7	-1.3
	100	1.33	14.3	25.0	-1.3	-2.5
2.5	5	0.04	0.5	1.0	0.0	-0.1
	10	0.08	1.0	2.0	-0.1	-0.2
	25	0.20	2.4	4.8	-0.2	-0.4
	50	0.40	4.8	9.1	-0.4	-0.8
	100	0.80	9.1	16.6	-0.8	-1.6
4.0	5	0.02	0.3	0.6	0.0	-0.1
	10	0.05	0.6	1.2	-0.1	-0.1
	25	0.12	1.5	3.0	-0.1	-0.3
	50	0.25	3.0	5.8	-0.3	-0.5
	100	0.50	5.8	11.0	-0.5	-1.0

*note : Figures based on specifications supplied by Van Damme Cables (VDC)*

## Networking Capability

NuQ series systems—these can be either passive or active loudspeakers operating with LMS series digital loudspeaker management systems, or self-powered loudspeakers, or a combination of both—may be connected together over a BvNet network, enabling real-time control and monitoring of multiple operating parameters from a central location with a PC running TurboDrive™ software, or even remotely via a VPN (virtual private network).

LMS-D2X series controllers are equipped with network cards as standard and are pre-configured with factory programs for all NuQ series models. Self-powered NuQ series loudspeakers are supplied with built-in network functionality.

## Computer system requirements

Minimum system requirements are as follows:

- PC with Pentium processor
- Windows NT, 2000, XP or Vista
- CD ROM or internet access
- RS232 or USB port

The TurboDrive™ software is available from the CD supplied with your product, or as a download from our website at [www.turbosound.com](http://www.turbosound.com). Always check the website for the latest version of the software.

## Hardware requirements

In addition to a desktop PC or laptop as described above, the following equipment is required in order to assemble a NuQ system network:

- Linea Research USB & RS232 Interface
- Linea Research Accessory Power Supply (optional)
- CAT5 type network cables
- Self-powered NuQ loudspeaker(s) **OR**
- NuQ loudspeaker(s) **AND** LMS-D24 or LMS-D26 loudspeaker management system(s)

### TurboDrive™ Quick Reference Setup

The following is a quick reference setup guide for networked systems. For more detailed setup instructions please refer to the TurboDrive™ User Guide, available from our web site at [www.turbosound.com](http://www.turbosound.com)

To create a network of NuQ systems follow the steps below:

1. **Install the TurboDrive software**  
from the CD supplied or download from the Turbosound website
2. **Install the drivers**  
If you are connecting via RS232 there is no need to install drivers. If you are connecting via a USB port install the drivers which can be found on the CD that was supplied with your Linea Research BvNet interface.
3. **Connect a LMS-D2X loudspeaker management system to a PC**  
BvNet is the method of connecting multiple devices over a network, and this is done with the Linea Research USB & RS232 Interface (available from Turbosound) which enables devices to be connected either using RS232 or the RS485 standard carried over CAT5-type cables.

#### Using RS232

Connect your computer to the RS232 port on the BvNet interface using a standard 9-pin serial cable. External power is required for RS232 operation and this should be supplied by the Linea Research Accessory Power Supply System.

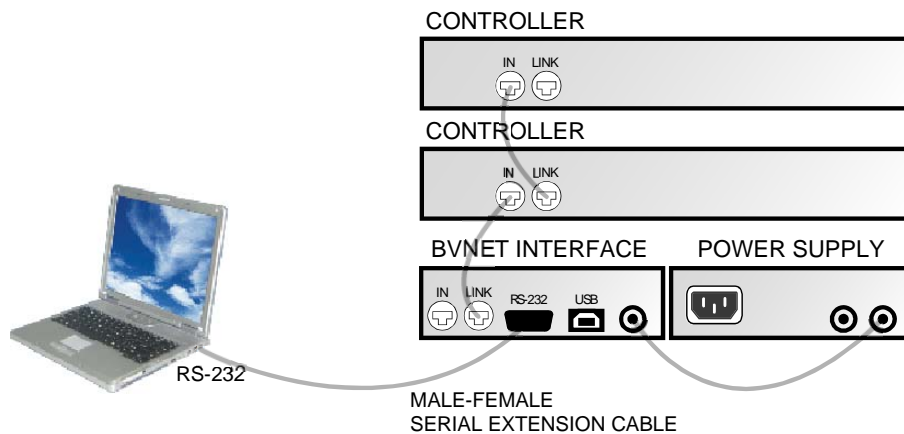

4. **Using USB**

Connect your computer to the BvNet interface using a USB Type A to USB Type B cable. External power is not required when using USB.

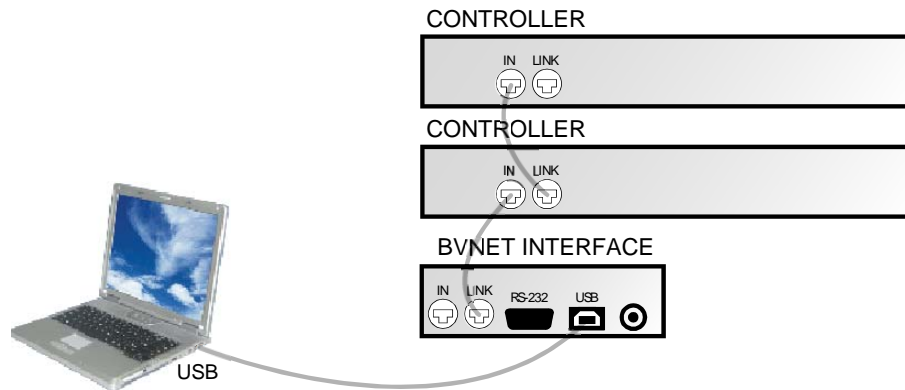

5. **Connect network devices** in a simple daisy-chain fashion with CAT5 type cables in the order you want them to appear in the devices window.
6. **Launch the TurboDrive™ software**  
On the first launch, the application will prompt for an authorisation code. The code is PJLUWZ
7. Select the **COM port** from Network > Com Port
8. Click the **Online** toolbar button
9. Click on one of the devices that appear in the tree view to **Launch the Panel**

## Loudspeaker Placement

### Choosing the best location

When using any loudspeaker system certain room parameters will affect the resultant sound quality and coverage. For example, any boundary like a wall or floor will lift certain frequencies. If you are placing speakers in a corner, then a lift at the bass end is to be expected and it may sound rather 'boomy'. This can be compensated for by moving the speaker or cutting low frequencies with an equaliser.

NuQ series speakers are designed to be flown in free space or mounted on specialist wall and ceiling brackets. When speakers are flown in free space then boundary effects are minimised. The result is a smooth frequency response without any boost at odd frequencies, but the bass end may appear subjectively light. In this case increase the sub-bass level to bring the low end up or add sub bass enclosures as necessary.

### Dispersion

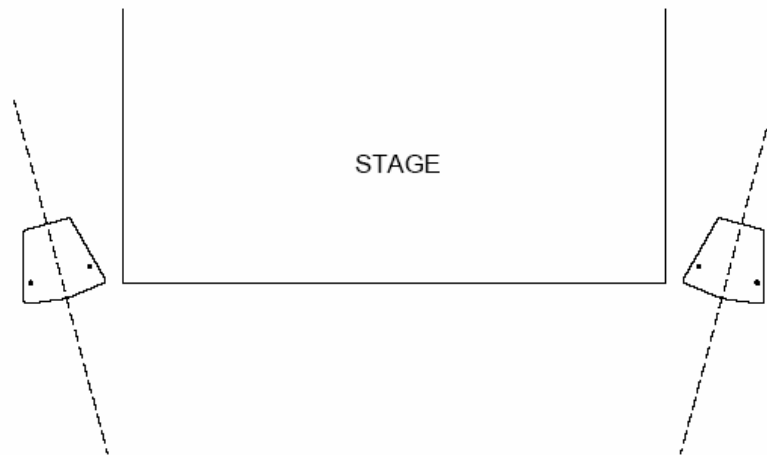

NuQ series enclosures are designed to provide respectably wide horizontal coverage; NuQ-8 and NuQ-10 offer 100° and the NuQ-12 and NuQ-15 offer 80° of horizontal dispersion respectively. This allows the majority of live sound applications to be covered with single enclosures placed individually to take advantage of this performance feature, for example either side of a stage in a pub, or small club environment, as shown here.

### **Calculating the sound pressure level at a known distance from the PA**

Sound intensity reduces rapidly as the distance from the source increases according to the inverse square law which, predicts that a doubling of distance will result in a reduction of  $\frac{1}{4}$  the original, equal to a drop of 6dB, providing there are no reflections or reverberation. For every 3dB increase of speaker output you need a doubling of input power.

For example, in an open space where the front seats are 6 meters (20 ft) from the sound source and the back seats are 60m (200 ft) from the sound source, you would expect the sound pressure to drop by a factor of 100 (= 20 decibels) between the front seats and the back seats.

In a 'real world' enclosed auditorium, this reduction is partially mitigated by the effects of reverberation in the distant field and, in the near field, because the speaker looks more like a wall source than a point source. Therefore the sound field in a room only behaves according to the inverse square law in a relatively narrow distance range.

It should be possible to make considered decisions regarding the particular models of speakers that are required based on their sensitivity and SPL (sound pressure level) in order to achieve the desired coverage and level.

### **Equalisation**

NuQ series enclosures are designed to provide smooth and even frequency response. They do not need excessive amounts of external equalisation to overcome the sonic deficiencies often found in many lesser designs.

In order to compensate for room acoustics, NuQ series enclosures require only minimal equalisation. As in any system, over-equalisation introduces phase shifts, distortion and a reduction in headroom, usually causing more problems than it cures. It is good practice to use as little equalization as possible, aiming to 'cut' frequencies rather than adding large amounts of 'boost'.

Most rooms will have resonances that will be excited at particular frequencies needing some cut to help tame the sound. These problems are most pronounced at the lower frequencies where loudspeakers generally exhibit very little directional control. Under most circumstances a 1/3 or 1/2 octave graphic equaliser will generally be adequate, with the fader settings applied smoothly and sparingly for the required room compensation.

If you find that the system needs a lot of boost at lower frequencies you probably need additional sub-bass units.

## System Configurations

The NuQ-8 and NuQ-10 two-way enclosures are passive loudspeaker systems. This means that they require only one amplifier channel for correct operation, the frequency splitting between the low frequency driver and the high frequency driver being accomplished by the internal passive crossover network in each enclosure. If subwoofers are used in a bi-amplified system in conjunction with these two-way enclosures, additional amplifier channels and external electronic crossovers will be required. The Turbosound LMS-D24/26 digital management systems are used for this purpose.

Many different system configurations of NuQ Series loudspeaker enclosures are possible to suit various portable and fixed installation requirements, ranging from live music and corporate events, cafes, bars and restaurants to theme parks, theatres and houses of worship. Listed below are a few common examples.

### System1 – Basic Stereo Passive setup

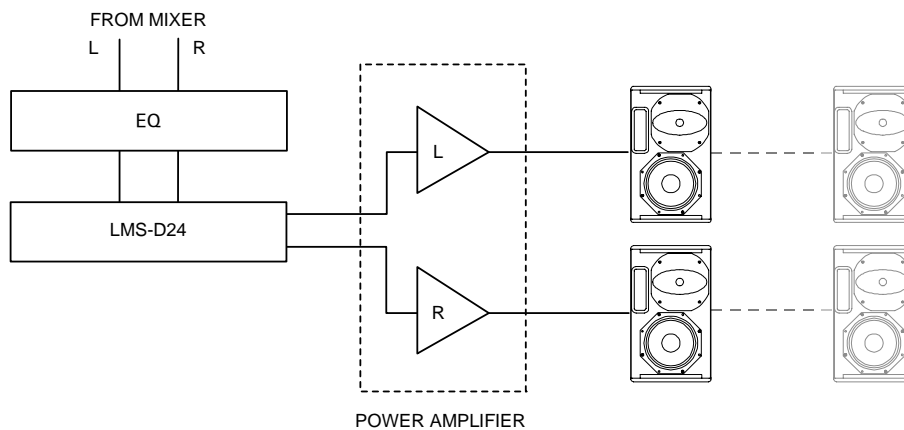

A single power amplifier supporting two NuQ series 2-way loudspeakers creates a standard stereo system. A further pair of NuQ loudspeakers could be connected using the loop-through connections, although this will result in a corresponding drop in impedance. With NuQ 2-way speakers having a nominal impedance of 8 ohms this would make a combined 4 ohm load that should be suitable for any good quality power amplifier (see amplifier considerations for more information).

NB: A stereo configuration is shown but this system could be run in mono.

NB: The EQ block is shown for tuning the room.

### System 2 – Stereo Passive setup with Bass Units and Active Crossover

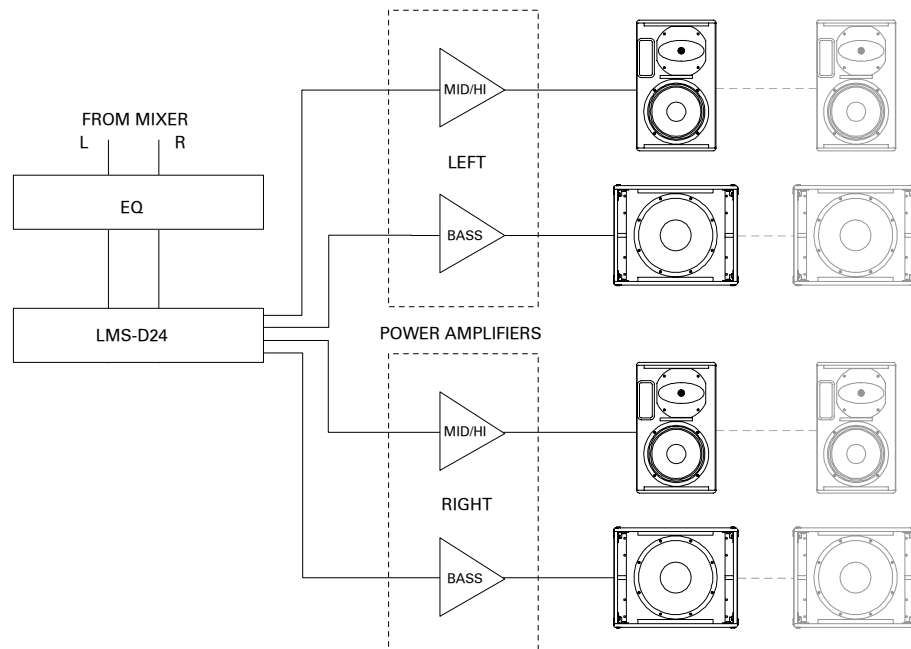

In this case an LMS-D24 is used to separate the bass and mid / high frequencies and feed them to the appropriate cabinets.

This system can be scaled up with the addition of further amplifiers and processors.

By substituting an LMS-D26 processor for the LMS-D24 there will be two extra channels available for adding perhaps another pair of mid/top cabinets through an extra stereo power amplifier.

The B15 bass speakers shown are rated at 8 ohms impedance so it is possible to run two cabinets from one amplifier, providing the amplifier is powerful enough, although additional amplifiers will still provide the best performance.

It is recommended to use a bass cabinet and a mid/top with each stereo amplifier as this helps distribute the load across the power supplies better.

NB: The EQ shown is for tuning the system to the room / venue.



**System 3 – Stereo Bi-amped setup with Active Crossover**

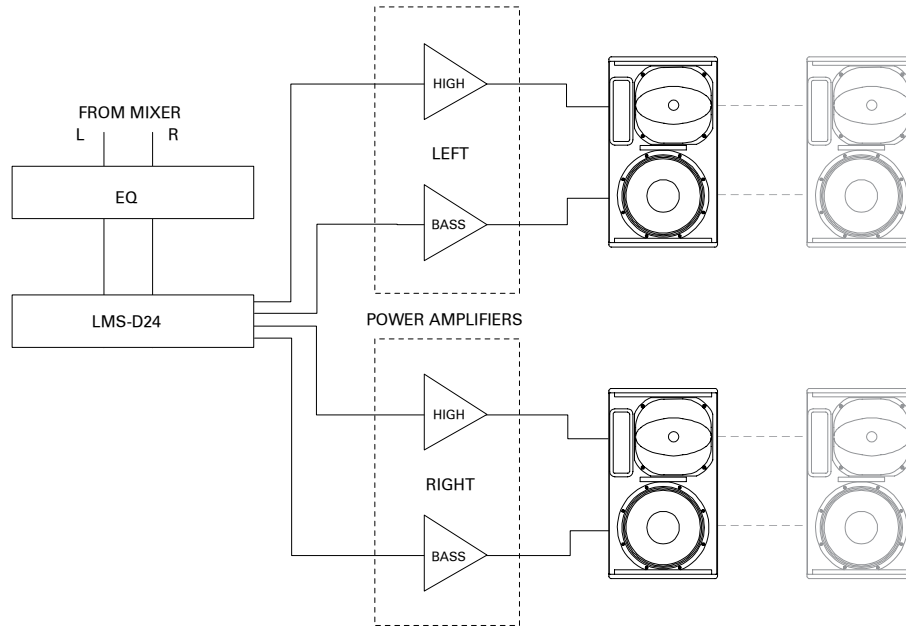

Note: **Bi-amp mode** must be selected on the rear panel of the loudspeaker before proceeding with this setup.

The LMS-D24 is used to separate the bass and high frequencies and feed them to the appropriate components within the enclosure. An additional pair of cabinets may be connected.

NB: The EQ shown is for tuning the system to the room / venue.

**System 4 – Stereo Bi-amped setup with Sub-bass units and Active Crossover**

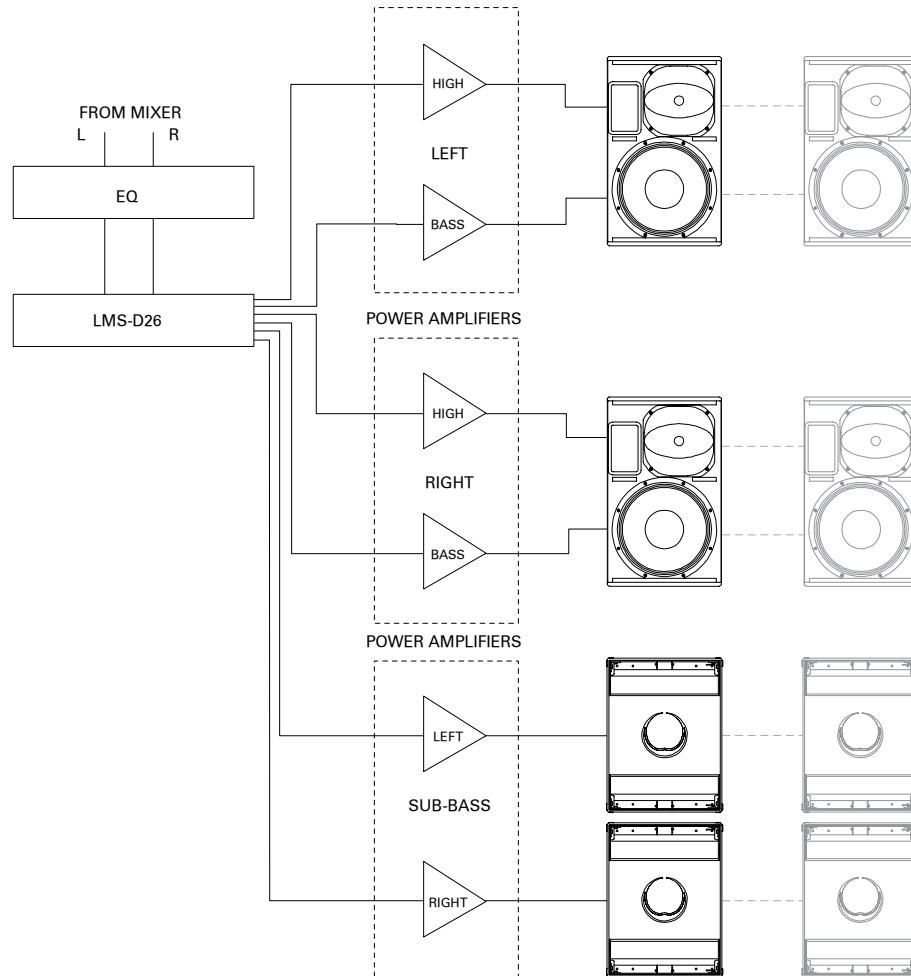

Note: **Bi-amp mode** must be selected on the rear panel of the two-way loudspeaker before proceeding with this setup.

The LMS-D26 is used to separate the audio into three frequency bands: high frequency, mid/bass frequency, and sub-bass. As with the previous systems, additional cabinets may be connected dependent on amplifier capability.

NB: The EQ shown is for tuning the system to the room / venue.

## **Loudspeaker Management Systems**

The concept of a Loudspeaker Management System is to provide all the processing electronics you might need in one box. This typically includes crossover functions, equalisation, limiters, delays and preset memories, that can store different set ups for various applications. A loudspeaker management system offers better audio quality, more precise control and loudspeaker protection because operating parameters can be precisely matched to the individual loudspeaker components.

Digital processing enables steeper roll-offs through the crossover areas to be designed, allowing more output from the speakers, as they are individually handling more appropriate bandwidths. Also, the addition of delay to the LF signal to match the arrival of the HF can help to make the image more intelligible. Therefore, it is much easier, and more efficient, to manipulate audio digitally in low voltage electronics than in the passive crossover networks found inside speakers.

The NuQ series has a choice of sub bass units (B15 or B18) that are designed to be used actively with the NuQ-8, NuQ-10, NuQ-12 and NuQ-15 mid/top cabinets. The Turbosound LMS-D24 and LMS-D26 loudspeaker management systems contain custom presets for all the NuQ series models along with a world-class audio specification.

### **Turbosound LMS series loudspeaker management systems**

The Turbosound LMS-D24 and LMS-D26 series are powerful DSP-based audio processing units designed for use with Turbosound loudspeaker systems and associated bass enclosures. The functions of multiple conventional products are combined in a compact 1U high 19" rack unit. They offer EQ, both for the room and the drivers, delay to align the wave front, and limiters that can be set for each individual component to ensure against damage and to protect the long term reliability of your speakers.

The LMS-D26 has two inputs and six outputs and the LMS-D24 has two inputs and four outputs, all electronically balanced. The units are configured to provide specific equalisation and crossover points aimed at optimizing the performance of these Turbosound loudspeaker systems. In addition, limiters, delays, eq, gain, polarity, and crossover filter controls are accessible to the user in order to match specific operation environments. The LMS series crossovers are designed for quick setup and adjustment via easy-to use front panel controls and, are ideally suited to both live sound and fixed installation.

#### **LMS series Features**

- Minimal signal path design, providing exceptional audio quality with carefully optimised processing and high performance converters for a >111dB dynamic range.
- Sonically superb ADC / DAC combination; a carefully matched pairing of the best devices from Burr Brown and Wolfson. Analogue Devices SHARC chip for DSP
- Extended bandwidth; 96 kHz sampling frequency provides for a nominally flat response to 40 kHz with minimal filtering.
- Audio-grade capacitors used in the analogue signal path for true audiophile performance and superior accuracy.
- Input delays of up to 400ms and output delays of up to 80ms can be set up on each output (mono) or pair of outputs (stereo) with fine resolution of 21µs steps to ensure perfect driver alignment.
- LF shelving filters to allow adjustment of the response in order to match variations of the acoustic conditions.
- Switching power supply that automatically adjusts to mains input voltages from 85 volts to 240 volts, allowing it be used anywhere in the world without inconvenient mains transformer adjustment.



## LMS-D24/6 Quick Reference Set Up

(LMS-D26 shown)

The LMS-D24 and LMS-D26 are designed for quick setup and adjustment via an easy-to-use menu structure accessed by front panel buttons and 3 rotary encoders. A high resolution backlit LCD display provides the user interface to the menu options and parameters being adjusted.

Input Signal Indicators—three pairs of LED's indicate signal present, +4dBu and input clip for both channels. The signal present LED's operate at approximately -40dBu, giving a useful indication of even relatively low input signal levels. The +4dBu LED's are intended to show nominal operating level and can also be useful for setting system gain structure. Clip LEDs warn the user of input overload and operate at +19dBu.

### Starting up

The unit will energise as soon as power is applied to the IEC inlet; there is no power switch. During the start up process the firmware application model number and version numbers are displayed and the outputs are muted until the unit has completed its internal checks. Once the start-up routines are complete and the unit is ready to pass audio, the DSP signal path will be restored to the current settings when it was last powered down and the audio signal is gradually ramped up to its correct level. At this stage the display shows the default screen with the memory location and name of the current Preset on the lower line of text.

### About Presets

The unit has 45 memory locations and there is a library of around thirty 'Factory' Presets to suit a range of Turbosound enclosures. Factory Presets are locked so they cannot be over-written although edited versions can be stored in the free preset locations. Details of all the Factory Presets can be found in Appendix A of the User Manual (LMSD2x pdf) in the downloads section of our website at [www.turbosound.com](http://www.turbosound.com).

Factory Presets contain some parameters that are fixed and hidden from view; typically crossover frequencies, output delay and some EQs; those settings that are a function of the loudspeaker cabinet design and should not require adjustment for different applications. The number and type of hidden parameters is dependant on the Factory Preset. The remainder of the DSP parameters are available for user manipulation.

### Preset Recall

- To select a Preset, press the **Recall** Button so the indicator above it illuminates.

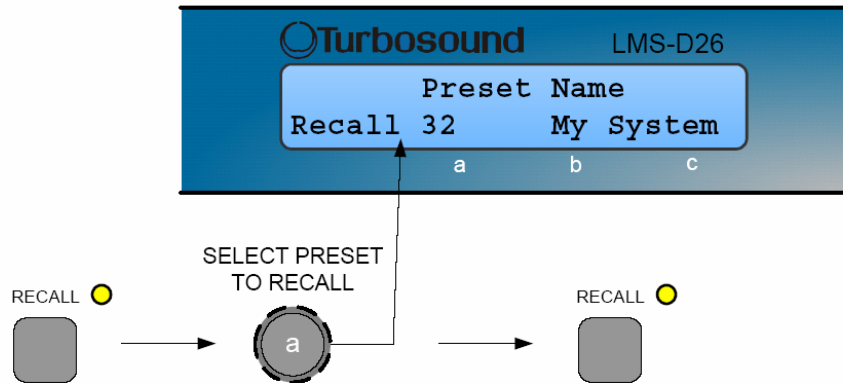

- Turn the left of the three parameter knobs (a) until the required Preset number is shown on the display.  
NB: Factory presets are indicated by a box symbol appearing after the Preset number.
- Press the **Recall** Button again to activate the Preset.  
NB: Pressing any other button will cancel the operation.

This process is deliberately in three stages in order to guard against accidental recall of incorrect Presets.

### Creating a user defined crossover

In addition to the Factory Presets the unit has two further 'Base Presets' for mono and stereo usage. These Base Presets are stored in locations 1 and 2 respectively, they can be used to develop settings for any loudspeaker combination and are recalled in the same way as the Factory Presets described above. These Presets are also locked but the user can name and store their own edited versions in any free preset location.

### Store button

To store a preset in a location, press the store button and use the encoders to select the memory location and name the preset. Pressing the store button again completes the task. Pressing any button other than store during the process cancels the procedure.

The store button allows the user to name a preset and choose which memory location it will be held in. Pressing store button again completes the process.

## **LMS-D24/D26 Audio Connections**

### **Audio Input connectors**

These are fully balanced and are wired pin 1 ground, pin 2 hot and pin 3 cold. The two inputs have pin 1 connected directly to the chassis and feed the signal processing chains. If an unbalanced source is used, a connection should be made between the pin 3 'cold' signal and the ground connection of the unbalanced source.

### **Audio Output connectors**

The processed outputs are impedance balanced, and are wired pin 1 ground, pin 2 hot and pin 3 cold. An unbalanced input may be driven by connecting pin 3 'cold' signal to the ground connection of the unbalanced destination input. Note that output pins 1 are ground lifted at audio frequencies but connected to ground at RF for good EMC performance. The intention being that the amplifiers the processor is driving should be responsible for the grounding of their input cable shields.

### **Presets and Secure mode**

A momentary button is fitted on the rear panel, between the output XLRs and the RS232 port. When activated, this will disable all the front panel controls so they cannot affect the signal path, making the unit secure against tampering. When in secure mode, the indicators still operate normally however; Presets cannot be stored or recalled. If the unit is not responding then check that Secure Mode is not active.

Note that the communications port is still active in secure mode.

### **Flying & Lifting / Rigging**

A versatile set of rigging parts has been designed for NuQ Series enclosures in order to give the portable user and installer a cost effective approach to flying and mounting, ranging from a single enclosure up to small arrays.

All riggable products are fitted with metric internal fixings. It is expected that external parts such as eyebolts, flying bridles, scaffold clamps, safety chains etc. will be obtained locally from the usual suppliers and used with the parts available from Turbosound. Note that only collared eyebolts can be used for lifting; please refer to British Standard BS4278 for further information.

Any installation, whether temporary or permanent, must be securely attached to the structure of the building using chain, steel wires or web straps which are certified and load rated for the purpose. The combined weight of the sound system, its cables and the rigging system must be safely carried by the points at which attachment is made to the building or structure. Great care must be taken in selecting the attachment points and methods, being absolutely sure of the load carrying capacity of points chosen.

**IMPORTANT NOTE: The rigging of loudspeaker systems is an extremely serious matter with potentially lethal consequences should anything go wrong. It is of vital importance that you, or other people rigging the system, are suitably qualified to do so and have a full understanding of all the factors involved with safety as a number one priority. Turbosound accepts no responsibility for any accident, damage or failure of any rigged system. This rigging information is specifically related to the requirements of the NuQ Series products only. For more detailed information on the whole topic of rigging various handbooks are available. If you are in any doubt contact your Turbosound dealer who will be able to refer you to an experienced rigging company.**



## Hardware Compatibility

Model	NuQ-8	NuQ-10	NuQ-12	NuQ-15
<b>Wall mount</b>	WB-20B PB-55	WB-20B PB-55	WB-55B PB-55	WB-55B PB-55
<b>Flying Yokes</b>	NuQ-FY8	NuQ-FY10	NuQ-FY12	NuQ-FY15
<b>Swivel brackets</b>	NuQ-SB8	NuQ-SB10	n/a	n/a
<b>Swivel bracket extenders</b>	NuQ-SBE8	NuQ-SBE10	n/a	n/a
<b>Horizontal array</b>	NuQ-TB	NuQ-TB	n/a	n/a
<b>OmniMount™</b>	Series 20.5	Series 60	Series 60	Series 120

## Speaker Pole and Tripod Stand Mounting

NuQ series two-way cabinets are equipped with pole mount sockets for portable use on 35mm speaker stands or poles. NuQ series bass cabinets are equipped with pole mount receptacles that allow two-way cabinets to be mounted at the correct height above the sub-bass unit.

## Use with Flying Yokes

Additional pole mounting flexibility is provided by adjustable flying yokes which allow two-way speakers to be angled downwards in order to achieve better audience coverage from a simple two-way-plus-sub-bass combination. The FY-PH pole holder adapter fixes to the yoke and mounts directly on top of the speaker pole or tripod stand.

## Truss Mounting

Cabinets can be rigged from standard truss systems using model-specific flying yokes and scaffold clamps. These allow virtually unlimited adjustment of rotation and downward angle to ensure accurate room coverage.

- Remove the four M10 countersunk screws on the sides of the cabinet using a 6mm Allen key
- Fit the flying yoke using the M10 bolts supplied and tighten
- Attach the scaffold clamp to the top bar of the flying yoke using the M12 bolt supplied and tighten
- Mount the loudspeaker to the truss, angle and rotate as required and tighten the thumbwheels

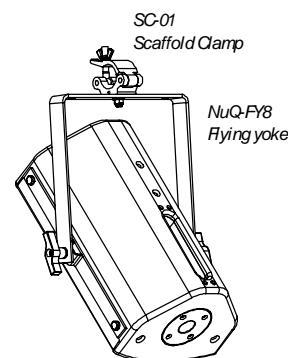

### Wall Mounting

NuQ cabinets can be installed using purpose-designed Turbosound wall brackets and OmniMount™ wall brackets from the 60 series and 120 series ranges. Please refer to the Hardware Compatibility chart earlier in this manual for the correct model. To install a cabinet with a Turbosound bracket:

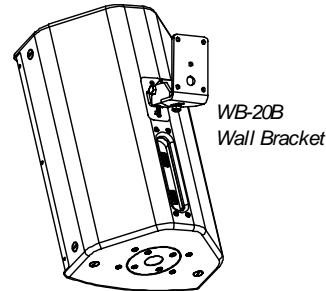

- Remove the blanking screws from the rear panel of the loudspeaker (there are two M6 hex countersunk screws on the NuQ-8 and NuQ-10, and four M6 hex countersunk screws on the NuQ-12 and NuQ-15).
- Disassemble the bracket and separate into its two component parts: the wall plate and ceiling plate.
- Install the wall plate in the venue using suitable wall fixings, ensuring that the plate is orientated such that the short section is at the bottom as shown.
- Assemble the speaker plate to the rear of the loudspeaker using the fixings provided and tighten the bolts.
- Using suitable lifting equipment offer up the cabinet to the wall, insert the long screw on the wall plate into the hole on the speaker plate, and assemble the flat washer and nylock nut. Angle the cabinet as required and tighten the nylock nut.

All NuQ cabinets equipped with a pole mount socket can be wall mounted using the universal PB-55 pole bracket. To install a cabinet using the PB-55 wall bracket:

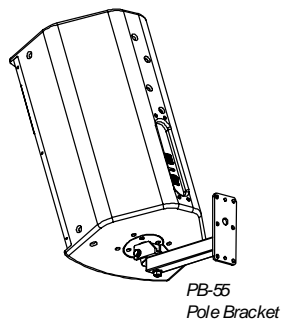

- Mount the PB-55 bracket to the venue using suitable fixings.
- Using suitable lifting equipment mount the cabinet on to the wall bracket and tighten the grub screw.
- Angle as required.

### Ceiling Mounting

Non-powered NuQ cabinets can be ceiling mounted using OmniMount™ ceiling brackets from the 60 series and 120 series ranges. The brackets attach to the rear of the cabinet and allow a range of angle adjustment. To install a cabinet using OmniMount ceiling brackets:

- Remove the blanking screws from the rear panel of the loudspeaker (there are two M6 hex countersunk screws on the NuQ-8 and NuQ-10, and four M6 hex countersunk on the NuQ-12 and NuQ-15).
- Mount the bracket to the ceiling using suitable fixings.
- Offer up the loudspeaker using suitable lifting equipment and attach the speaker plate to the rigging points on the rear of the loudspeaker.
- Angle as necessary and tighten all fixings.

### Small Loudspeaker Arrays

NuQ series loudspeakers offer two choices of dispersion pattern, and this facility gives considerable flexibility of coverage when assembling small loudspeaker arrays. By rotating the Converging Elliptical Waveguides within the cabinet it is possible to obtain either wide horizontal coverage or narrow horizontal coverage. The table below shows the possible dispersion options for each model.

Model	NuQ-8	NuQ-10	NuQ-12	NuQ-15
<b>Factory-supplied</b>	100°H x 60°V	100°H x 60°V	80°H x 50°V	80°H x 50°V
<b>HF horn rotated</b>	60°H x 100°V	60°H x 100°V	50°H x 80°V	50°H x 80°V

### Horizontal Rigging

Where ceiling height is limited or for other aesthetic reasons it may be desirable to mount cabinets horizontally. The NuQ-SB horizontal swivel bracket is used for this purpose, and can be fixed directly to a ceiling, or truss mounted using the SC-01 scaffold clamp. The swivel bracket is attached to the M10 rigging point at the top of the cabinet and to the pole mount socket at the bottom. In order to maintain a wide horizontal coverage pattern when flying the cabinet horizontally the high frequency horn should be rotated through 90°. For instructions on rotating the horn please refer to the servicing section of

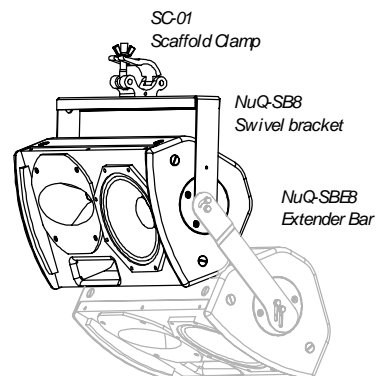

this user manual.

### **Small Vertical Array**

A second cabinet can be suspended underneath as shown with the addition of NuQ-SBE extender bars which are available as left and right pairs. With both HF horns rotated through 90° from the factory-supplied orientation the combined coverage pattern will be around 100°H x 110°V.

### **Using the T-bar**

The NuQ-TB T-bar allows two NuQ-8 or NuQ-10 cabinets (NuQ-12 and NuQ-15 cabinets are not compatible with the T-bar) to be mounted together in a compact horizontal array for corporate / industrial applications—either on top of a speaker pole or tripod stand, or suspended from a truss system using a scaffold clamp—in order to widen the available horizontal dispersion from the speaker system for better audience coverage. The FY-PH pole holder is a simple fitting that allows the T-bar to adapt for use with standard 35mm speaker poles and stands.

Each cabinet can be individually rotated and angled independently.

For optimum smooth coverage the NuQ-8 and NuQ-10 should be played at approximately 45° with the HF horns in the factory-supplied orientation, which will give a combined coverage pattern of around 145°H x 60°V. With both HF horns rotated for a wider vertical dispersion the splay angle should be reduced to around 25°, giving a combined coverage pattern of approximately 85°H x 100°V.

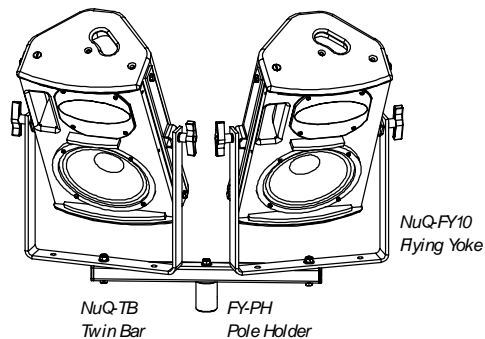

### **To create a horizontal array for speaker stand / pole mounting:**

- Assemble the flying yokes and attach them to the cabinets as detailed above using the fixings provided with the flying yokes.
- Swing the yokes around to the bottoms of the cabinets and attach them to the ends of the T-bar using the fixings provided.
- Attach the FY-PH pole holder to the middle of the T-bar using the screws provided.
- Lift the assembly on to the speaker pole or tripod stand and tighten the wing nut. Angle as required.

**To create a horizontal array for truss mounting:**

- Assemble the flying yokes and attach them to the cabinets as detailed above using the fixings provided with the flying yokes.
- Swing the yokes around to the tops of the cabinets and attach them to the ends of the T-bar using the fixings provided.
- Attach the SC-01 scaffold clamp to the middle of the T-bar using the screws provided.
- Lift the assembly on to the truss structure and point the array as required.

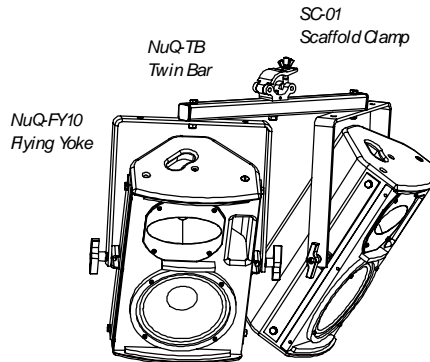

**Flying Single Enclosures**

All NuQ series cabinets, including low frequency enclosures, can be rigged in permanent installations using optional M10 shoulder eyebolts (available from Turbosound or third party suppliers). These can be attached to the rigging points provided on the top and back of the cabinet. The rigging point at the rear of the cabinet is used to alter the downward angle of the enclosure.

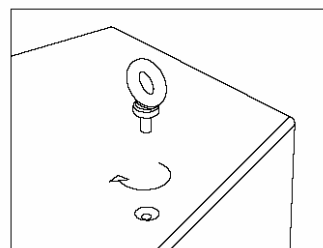
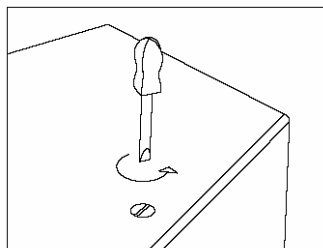

As supplied, these rigging points are fitted externally with M10 countersunk slot-head screws. To facilitate rigging of the enclosure simply remove these M10 screws and replace them with M10 x 18mm shoulder eyebolts using a suitable thread locking compound to avoid the possibility of loosening.

Note: Eyebolts must have a thread length of at least 18mm (3/4").

**user manual**  
**NuQ series**

---

NOTE: The rigging points are designed to suspend single enclosures only. There is no facility to hang an additional cabinet below a flown NuQ series enclosure.

### **Use of Thread Locking Compounds**

When assembling flying hardware to NuQ Series loudspeaker enclosures it is advisable to use thread-locking compounds to eyebolts and other bolts in order to avoid any possibility of loosening.

The recommended thread-locking compound is Loctite 222.

The threaded rigging points used in NuQ Series enclosures are manufactured from zinc-plated mild steel. Therefore, and additionally if the external bolts used are zinc-plated, zinc-passivated, stainless steel or anodised (as the majority are), then the corresponding activator, Loctite 7471, should be used to achieve 100% performance.

**Application:** Spray Loctite 7471 into the thread holes and allow to evaporate. Apply Loctite 222 thread locking compound to the bolts prior to fitting, allowing sufficient to fill all the engaged threads. Assemble components and tighten as necessary.

The parts may be disassembled by hand if required.

### **Servicing Information**

If any of the drive units in your NuQ series cabinet should cease functioning and need a replacement re-cone or diaphragm, you are advised to remove the faulty unit from the cabinet and send it to a professional service centre authorised to repair Turbosound loudspeakers.

#### **Removal of the low frequency driver – B15 front loaded bass enclosure**

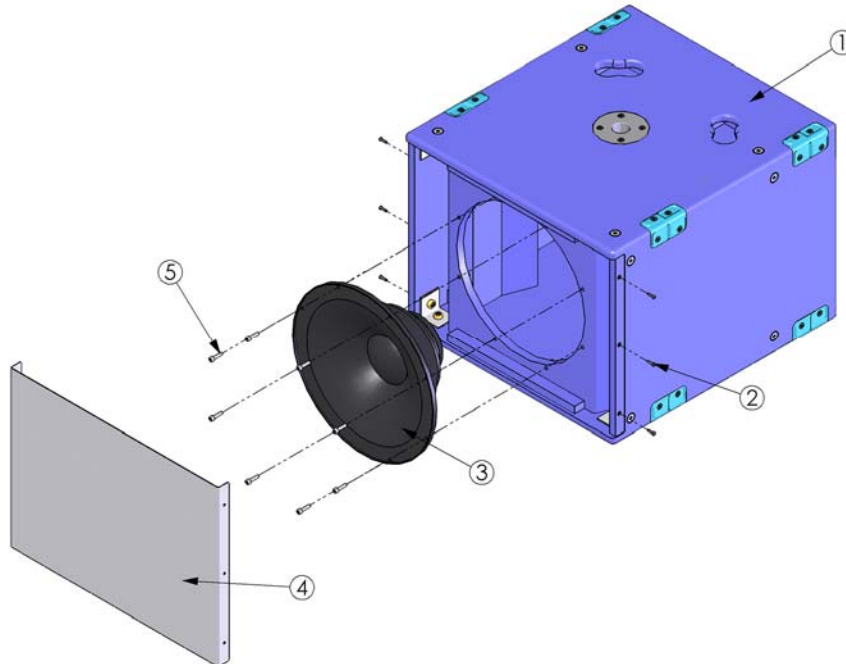

The perforated steel loudspeaker grille (4) is held in place by six M5 button head screws (2), three on each side of the cabinet. Remove these grille retaining screws and set the grille aside for later re-assembly.

Undo the M5 x 35 socket head screws (5) holding the driver (3) in place, remove these together with the flat washers and spring washers, and carefully lift it out and away from the cabinet (1). Make a note of the driver terminal polarity for later reconnection. Disconnect the cables from the drive unit and completely remove the driver from the cabinet being careful not to damage the cone or suspension. Do not place the driver near to any equipment or media that may be adversely affected by strong magnetism, e.g. CRT monitors or magnetic tape of any kind.

To reinstate the speaker simply reverse the above procedure, making sure you observe the correct polarity when reconnecting the cables back into the terminals of the drive units. Tighten the fixing screws.



### Removal of the low frequency driver – B18 bandpass bass enclosure

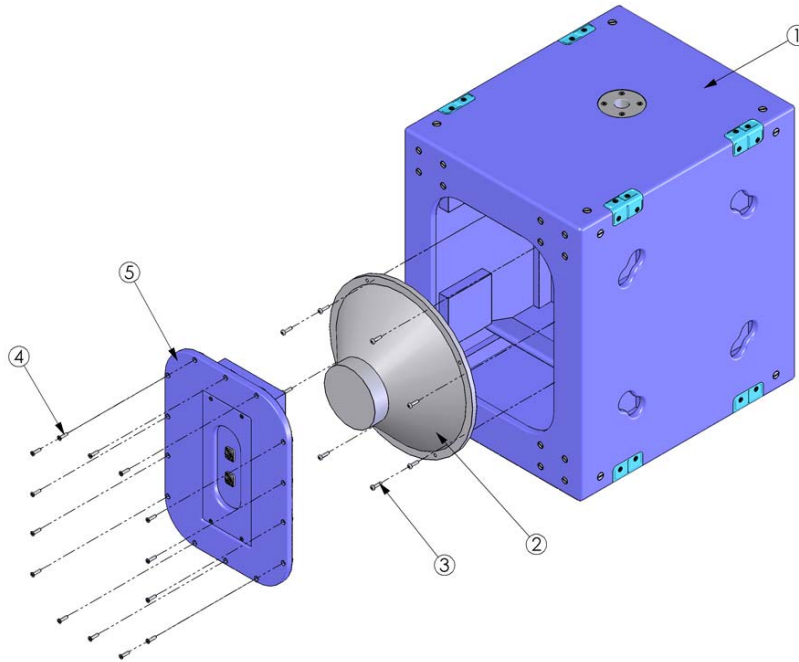

Remove the No.12 x 1 ½" screws (4) holding the rear access door (5) in place and set it aside for later re-assembly.

Undo the M6 x 35 hex head screws (3) holding the low frequency driver (2) in place, remove these together with the flat washers and spring washers, and carefully lift the driver out and away from the cabinet (1). Make a note of the driver terminal polarity for later reconnection. Disconnect the cables from the drive unit and completely remove the driver from the cabinet being careful not to damage the cone or suspension. Do not place the driver near to any equipment or media that may be adversely affected by strong magnetism, e.g. CRT monitors or magnetic tape of any kind.

To reinstate the speaker simply reverse the above procedure, making sure you observe the correct polarity when reconnecting the cables back into the terminals of the drive units. Tighten the fixing screws.

### Removal of the HF compression driver and LF driver – two-way cabinets

The perforated steel loudspeaker grille is held in place by six M5 button head screws, three on each side of the cabinet (NuQ-8 illustrated here). Remove these grille retaining screws and set the grille aside for later re-assembly.

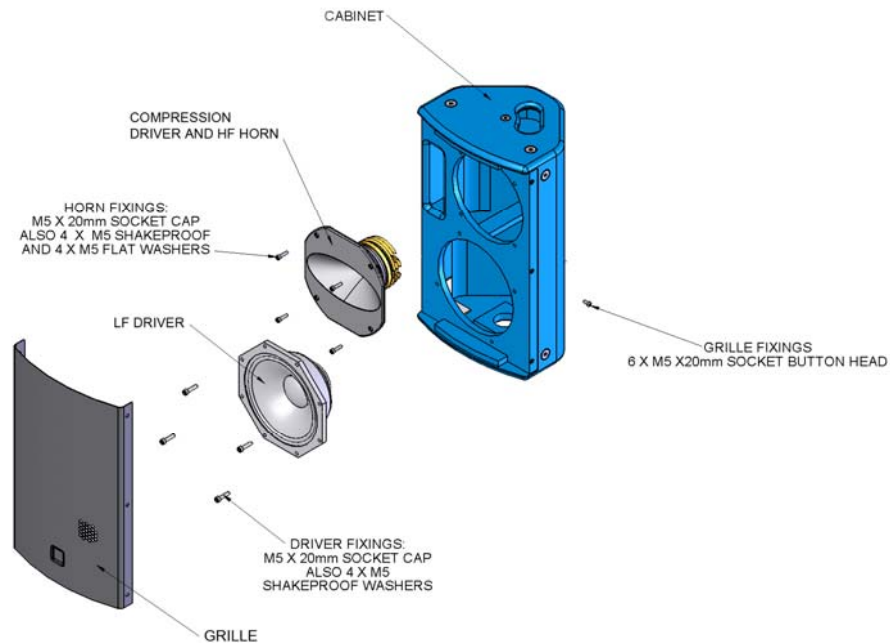

Undo the screws holding the low frequency driver in place and carefully lift it out and away from the cabinet. Make a note of the driver polarity for later reconnection. Disconnect the cables from the drive unit and completely remove the driver from the cabinet being careful not to damage the cone or suspension. Do not place the driver near to any equipment or media that may be adversely affected by strong magnetism, e.g. CRT monitors or magnetic tape of any kind.

Remove the horn/driver assembly by unscrewing the four screws holding the flange in place. Lift it out and away from the cabinet. The high frequency driver can now be disassembled from the HF horn.

To reinstate the driver(s) simply reverse the above procedure, making sure you observe the correct polarity when reconnecting the cables back into the terminals of the drive units.

## About EASE Data

Sound system projects are more likely to go to plan when you have a reliable indicator in advance of how the speaker system will perform in the venue. Turbosound engineers are able to assist you with your system design using the industry-standard EASE program to aid in the quest to find the perfect system for the job. Although we cannot replace the role of an acoustical consultant, we can provide a good indication of system performance to back up the proposal.

Statistically, more jobs are won and more sales are made when a project has been properly and scientifically designed, along with the facility to show the client a convincing visual representation of the finished design. This cuts a large amount of guesswork out of the process, and is the reason why we actively encourage you to make use of our design resources to help you or your customers to win that next job. EASE is also a useful tool for addressing acoustic issues in the venue, for example to justify adding acoustic treatment to a room such as cladding a wall or balcony face. Having a graphical model can strengthen the proposal and ultimately ensure a better result.

## Overview

EASE (Enhanced Acoustic Simulator for Engineers) is a sophisticated sound system design tool and acoustic simulation software package for Windows PCs, created by SDA (Software Design Ahmert GmbH, Berlin). It enables extremely accurate acoustic calculations to be realised both for indoor venues and outside spaces. In this way acoustic parameters and properties can be calculated for audience areas or even particular listener seats. EASE is particularly useful where a large number of speakers may be used, i.e. in concert halls, stadiums and public buildings.

The EASE application itself is comprehensive and can account for a wide range of surface properties, i.e. absorption and dispersion and also early reflections, directivity and phase characteristics. 3D acoustical models can be created for computing parameters such as RT (Reverb Time), IR (Impulse Response) and SPL (Sound Pressure Level) distribution for sound reinforcement and speech intelligibility.

There are a variety of module upgrades that enhance EASE's capabilities, such as AURA (Analysis Utility for Room Acoustics) which has become a standard for modelling spaces in three dimensions along with the VISION rendering engine. EASE VIEW loads OpenGL and Mapping files as used in the design

EARS is an auralisation module that allows the determination of audio quality, and the comparison of old against new sound system installs, by locating sound sources in the virtual room, or open air space, using convolving and binaural techniques.

EASERA is used for evaluating and measuring the transmission properties of both spaces and electrical equipment.

EASE FOCUS is a free 2D 'aiming' program that can be used for aligning speaker stacks and particularly arrays. It uses configuration files in ASCII format made using compiler software which have the extension .efo.

### **Use of Turbosound EASE data**

Turbosound provides pre-measured EASE data to aid sound system designers in making appropriate choices with the type and positioning of speakers in the required venue. The suitability of certain models can be assessed and the installation can be improved by adapting the frequency response consequently.

The speakers are measured from the centre of an entire globe with 5 degree resolution and third octave frequency resolution.

EASE data is available from our download FTP server at <ftp://ftp.turbosound.com>

## Technical Specifications

### Non-Powered Enclosures

Model	NuQ-8	NuQ-10	NuQ-12	NuQ-15	B15	B18
<b>Dimensions HxWxD mm (inches)</b>	464x272x220 18.3x10.7x8.7	525x318x258 20.7x12.5x10.2	655x373x340 25.8x14.7x13.4	712x430x385 28x16.9x15.2	464x574x620 18.3x22.6x24.4	768x574x700 30.2x22.6x27.6
<b>Net Weight</b>	9.5kg (20.9lbs)	12kg (26.4lbs)	20kg (44lbs)	26kg (57.2lbs)	36.5kg(80.3lbs)	65kg (143lbs)
<b>LF driver</b>	1 x 8" (203mm)	1 x 10" (254mm)	1 x 12" (305mm)	1 x 15" (381mm)	1 x 15" (381mm)	1 x 18" (457mm)
<b>HF compression driver</b>	1 x 1" (25mm)		1 x 1.4" (35mm)		n/a	
<b>Frequency Response ±4dB</b>	60Hz - 20kHz	55Hz - 20kHz	55Hz - 20kHz	50Hz - 20kHz	45Hz - 120Hz	40Hz - 150Hz
<b>Nominal Dispersion</b>	100°H x 60°V @ -6dB points		80°H x 50°V @ -6dB points		n/a	
<b>Power Handling</b>	250 watts cont. 500 watts pgm	300 watts cont. 500 watts pgm	450 watts cont. 900 watts pgm	600 watts cont. 1200 watts pgm	400 watts cont. 800 watts pgm	600 watts cont. 1200 watts pgm
<b>Recommended amplifier power @ 8 Ohms</b>	500 watts	500 watts	900 watts	1200 watts	800 watts	1200 watts
<b>Sensitivity 1 watt @ 1 metre</b>	94dB	96dB	98dB	100dB	100dB	102dB
<b>Max SPL continuous-&gt; peak-&gt;</b>	118dB 124dB	121dB 127dB	127dB 133dB	129dB 135dB	126dB 132dB	130dB 136dB
<b>Crossover</b>	2k5Hz		1k6Hz		12dB/octave low-pass at 150Hz	
<b>Nominal Impedance</b>	8 ohms					
<b>Construction</b>	12mm (1/2") birch plywood		15mm (5/8") birch plywood		18mm (3/4") birch plywood	
<b>Grille</b>	Powder coated perforated steel mesh, backed with black reticulated foam					
<b>Connectors</b>	(2) Neutrik Speakon NL4MP wired pin1+: positive, pin 1-: negative, pins 2+ and 2- N/C		(2) Neutrik Speakon NL4MP wired (passive) pin1+: positive, pin 1-: negative, pins 2+ and 2- N/C, wired (active) pin1+: LF positive, pin 1-: LF negative, pin2+: HF positive, pin2-: HF negative		(2) Neutrik Speakon NL4MP wired pin1+: positive, pin 1-: negative, pins 2+ and 2- N/C	
<b>Finishes</b>	Black semi-matt textured paint, optional white textured paint					

Note: All two-way models feature a rotatable Converging Elliptical Waveguide™ which can be rotated through 90° in the cabinet.

**Self-powered Enclosures**

Model	NuQ-8DP	NuQ-10DP	NuQ-12DP	NuQ-15DP	B15DP	B18DP
<b>Dimensions HxWxD</b>	464x272x252 18.3x10.7x9.9	525x318x281 20.7x12.5x11.1	655x373x340 25.8x14.7x13.4	712x430x385 28x16.9x15.2	464x574x620 18.3x22.6x24.4	768x574x700 30.2x22.6x27.6
<b>Net Weight</b>	13kg (28.6lbs)	15.5kg (34.1lbs)	23kg (50.6lbs)	29kg (63.8lbs)	39kg (85.8lbs)	67.5kg (148.5lbs)
<b>LF driver</b>	1 x 8" (203mm)	1 x 10" (254mm)	1 x 12" (305mm)	1 x 15" (381mm)	1 x 15" (381mm)	1 x 18" (457mm)
<b>HF compression driver</b>	1 x 1" (25mm)		1 x 1.4" (35mm)		n/a	
<b>Frequency Response ±4dB</b>	60Hz - 20kHz	55Hz - 20kHz	55Hz - 20kHz	50Hz - 20kHz	45Hz - 120Hz	40Hz - 150Hz
<b>Nominal Dispersion @-6dB points</b>	100°H x 60°V		80°H x 50°V		n/a	
<b>Maximum SPL continuous-&gt; peak-&gt;</b>	118dB 124dB	121dB 127dB	127dB 133dB	129dB 135dB	126dB 132dB	130dB 136dB
<b>Construction</b>	12mm (1/2") birch plywood		15mm (5/8") birch plywood		18mm (3/4") birch plywood	
<b>Amplifier</b>	Class D					
<b>Power Output</b>	500 watts @ 8 ohms		2 x 800 watts @ 8 ohms			
<b>Dynamic Range</b>	110dB					
<b>Input clip</b>	10dBu					
<b>Bandwidth</b>	20Hz - 20kHz (±0.5dB)					
<b>Grille</b>	Powder coated perforated steel mesh, backed with black reticulated foam					
<b>Power Requirements</b>	100v to 230v AC, 50-60Hz					
<b>Connectors</b>	Input: (1) XLR female, Link: (1) XLR male, wired pin 2 hot, (1) Neutrik Powercon mains, (2) RJ45 network ports					
<b>Finishes</b>	Black semi-matt textured paint, optional white textured paint					

Technical Specification Notes:

Frequency response is measured on axis. Nominal Dispersion and sensitivity are an average over stated bandwidth. Maximum continuous SPL is measured by using unweighted diode-clipped pink noise in a half space environment. Maximum peak SPL is verified by subjective listening tests of familiar program material, before the onset of perceived signal degradation

NB: Due to continuing product improvement these specifications are subject to change.

### Spare Parts List

Model	NuQ-8/DP	NuQ-10/DP	NuQ-12/DP	NuQ-15/DP	B15/DP	B18/DP
<b>LF Driver</b>	LS-8093	LS-1024	LS-1221	LS-1528	LS-1526	LS-1814
<b>Re-cone Kit</b>	RC-8093	RC-1024	RC-1221	RC-1528	RC-1526	RC-1814
<b>HF Driver</b>	CD-115		CD-213.2		n/a	
<b>HF Diaphragm</b>	RD-115		RD-213.2		n/a	
<b>Passive Crossover Network</b>	PX-8	PX-10	PX-12	PX-15	n/a	

## **Warranty**

### **Limited Warranty**

This Turbosound loudspeaker product is warranted to the original end-user purchaser and all subsequent owners for a period of two (2) years from the original date of purchase.

### **Warranty Coverage**

Warranty coverage includes defects in materials and workmanship. It does not include:

- damage caused by accident, misuse, abuse, neglect or modification by any other person other than an authorised Turbosound representative,
- damage caused by overdriving, use with unsuitable amplifiers or amplifier failure,
- damage caused by failure to operate the product in accordance with the instructions contained in the user's manual,
- damage occurring during shipment in transit,
- claims based upon any misrepresentations by the seller,
- products which do not have the original components as specified in the product engineering information,
- products on which the serial number has been removed or defaced.

### **Shipping**

Should any fault develop with a component of your Turbosound system, please return the product, freight pre-paid, in its original packing carton, along with proof of purchase such as the original bill of sale or receipted invoice, and a description of the suspected fault to:

Turbosound Ltd. (Att: Customer Service), Star Road, Partridge Green, West Sussex RH13 8RY, United Kingdom, or your local authorised Turbosound representative.

The product serial number must be quoted in all correspondence relating to the claim. Insurance is recommended, as Turbosound or its representatives are not liable for loss or damage in transit. Turbosound will pay for return freight costs should repairs be covered under warranty.



**Incidental and consequential damages**

Turbosound's liability is limited to the repair or replacement, at our option, of any defective product, and shall not be liable for any incidental and consequential damages including, without limitation, injury to persons or property or loss of use.

**Limitation of implied warranties**

All implied warranties, including warranties of merchantability and fitness for a particular purpose, are limited in duration to the length of this warranty.

This warranty is in addition to, and in no way detracts from, your statutory rights as a consumer. No other warranty is expressed or implied.

Please record your purchase information below for future reference:

Dealer Name .....

Dealer Address .....

.....

.....

Post / Zip Code .....

Dealer telephone / fax .....

Invoice number .....

Date of purchase .....

Unit serial number .....

**Notes**

## Free Manuals Download Website

<http://myh66.com>

<http://usermanuals.us>

<http://www.somanuals.com>

<http://www.4manuals.cc>

<http://www.manual-lib.com>

<http://www.404manual.com>

<http://www.luxmanual.com>

<http://aubethermostatmanual.com>

Golf course search by state

<http://golfingnear.com>

Email search by domain

<http://emailbydomain.com>

Auto manuals search

<http://auto.somanuals.com>

TV manuals search

<http://tv.somanuals.com>