



QLIGHT™ SERIES

USER MANUAL

TQ-230

TQ-308

TQ-310

TQ-315

TQ-445

TQ-425

TQ-115

Turbosound Ltd.

Star Road, Partridge Green

West Sussex RH13 8RY United Kingdom

Tel: +44 (0)1403 711447 Fax: +44 (0)1403 710155

Web: www.turbosound.com

Issue 1.2 July 2006

Copyright © 2006 Turbosound Ltd.

CONTENTS

Thanks	4
Unpacking the QLight™ series loudspeaker	4
Features	5
Product Range Summary	6
TQ-230	6
TQ-308	6
TQ-310	6
TQ-315	6
TQ-445	6
TQ-425	7
TQ-115	7
System requirements	8
Amplifier considerations	8
Equalisation	9
Dispersion	9
Converging Elliptical Waveguide™	10
Mounting and Fixing	11
Rigging Hardware	11
Summary of rigging options	17
Permanent installations	17
Choosing the best location	18
Maintenance	19
TQ-230 - Removal of the drivers	19
TQ-308/TQ-310/TQ-315 – Removal of the drivers	19
TQ-445 - Removal of the 12"/1" driver	19
TQ-115 - Removal of the 15" driver	20
TQ-425 – Removal of the 15" driver(s)	20
TQ-445 - Removal of the midrange drive unit and horn assembly	20
Appendix A	21
Spares and accessories	21
Flying accessories	22
Appendix B: Technical specifications	24
Appendix B: Technical specifications	24
Appendix C: Warranty	26

Limited Warranty 26
Warranty Coverage..... 26
Shipping 26
Incidental and consequential damages 27
Limitation of implied warranties..... 27

Introduction

Thanks

Thank you for choosing a QLight™ series loudspeaker product for your application. Please spare a little time to read the contents of this manual, so that you can obtain the best possible performance from this unit.

All TURBOSOUND products are carefully engineered for world class performance and reliability.

If you would like further information about this or any other TURBOSOUND product, please contact us. Detailed product information is available on our web site at www.turbosound.com

We look forward to helping you in the near future.

Congratulations, you have just purchased a professional loudspeaker system from the renowned Turbosound range, designed to give you the best in audio quality and many years of reliable, trouble free operation. It offers superior audio quality, unsurpassed vocal projection, full technical documentation including EASE data, and comprehensive rigging and flying hardware options. Please read through this manual carefully before you attempt to operate the loudspeaker system. It contains valuable information enabling you to quickly and easily set up and connect the loudspeakers, important system and set-up checks together with positioning and mounting instructions.

Unpacking the QLight™ series loudspeaker

After unpacking the unit please check carefully for damage. If damage is found, please notify the carrier concerned at once. You, the consignee, must instigate any claim. Please retain all packaging in case of future re-shipment.

FEATURES

- **Superb audio quality:** carefully designed and matched loudspeaker drive units are used to give you exceptional performance and many years of reliable, trouble free operation.
- **Ease of use:** QLight™ series products are exceptionally easy to set up and use with the minimum of technical knowledge required.
- **Multi-way designs:** the exclusive use of cone transducers in the mid frequency bands guarantees seamless crossover regions, as well as greater power handling, lower distortion and less mechanical stress.
- **Custom-designed drive units:** a special 12"/1" co-axial driver was developed for the TQ-445 which allows this three-way enclosure to exceed the performance of equivalent-sized traditional two-way designs.
- **Wide dynamic range:** all drive units are capable of handling large amounts of amplifier power in order to achieve high SPL without sacrificing headroom.
- **Controlled dispersion:** QLight™ series mid/high frequency enclosures feature controlled dispersion patterns which minimise room reflections and focus sound coverage directed at audience areas without overspill.
- **Aligned components:** mid and high frequency components are physically aligned to ensure perfect time arrival at the listener's ear.
- **Solid construction:** all QLight™ series cabinets are built from high grade birch plywood, rebated, screwed and glued together for maximum rigidity and durability.
- **Integral rigging points:** fitted as standard, enabling use with optional Turbosound flying hardware for all types of fixed installations and mobile sound reinforcement applications.
- **Compact enclosures:** the overall dimensions of QLight™ series enclosures have been kept as small as possible to enable portable use as well as fitting easily into permanent installations.

PRODUCT RANGE SUMMARY

TQ-230

The TQ-230 is a compact passive 2-way loudspeaker with two 5" woofers designed for foreground, background and in-fill music applications as well as a theatre under-balcony loudspeaker. Its wide horizontal dispersion and a rotatable high frequency horn enable horizontal or vertical orientation. Intended for portable use as well as for fixed installations, the TQ-230 is provided with rigging points to enable use with eyebolts, wall and ceiling brackets, swivel brackets and pole brackets.

TQ-308

The TQ-308 is a compact 8" quasi-trapezoidal passive 2-way loudspeaker designed for use with Turbosound digital controllers such as the LMS-D4 or LMS-D6. Its primary application is as a small and unobtrusive speech and music system ideal for corporate rentals or permanent installs such as theatres, bars and small clubs. Its rotatable 100° x 60° HF horn allows considerable flexibility of physical orientation as well as audience coverage options. Flying and mounting options include pole mounts, pole brackets and speaker stands; integral rigging points for use with Turbosound and OmniMount™ wall and ceiling brackets, and swivel brackets.

TQ-310

The TQ-310 is a full range 10" quasi-trapezoidal passive 2-way loudspeaker designed for use in mobile speech and music sound reinforcement applications with LMS-D4 or LMS-D6 digital controllers, including use as a floor monitor. It is also ideal for use in a wide range of fixed installations using various rigging options which include adjustable wall and ceiling brackets, swivel brackets, flying frames and RT-767 ring type fly points.

TQ-315

A switchable bi-amp/passive 15" full range quasi-trapezoidal 2-way loudspeaker that doubles as front-of-house and floor monitor applications when used with Turbosound LMS-D4 or LMS-D6 digital controllers. Its 80° x 55° HF horn pattern is rotatable through 90° to allow a range of coverage options. Fixed installs are catered for by a range of rigging options, including wall and ceiling brackets, flying frames, swivel brackets and RT-767 ring type fly points

TQ-445

The TQ-445 is a compact three-way bi-amped full range enclosure that offers unprecedented levels of audio clarity and definition. It combines a co-axial LF/HF driver with a proprietary 6.5" midrange cone transducer in a vented trapezoidal enclosure, providing focused directivity and considerable vocal projection. The TQ-445 is designed for use with the LMS-D6 digital loudspeaker management system, which provides model-specific crossover, equalisation and limiting functions. In order to extend the effective bass frequency range of the loudspeaker by a further octave the use of the complementary TQ-425 subwoofer is recommended.

TQ-425

The **TQ-425** is a front loaded, double neodymium 15" vented subwoofer designed to combine with QLight™ series enclosures to give a high quality, full range sound reinforcement system ideally suited to all corporate, industrial, theatre and audio visual applications. When used with the LMS-D6 digital crossover it will reproduce high sound pressure levels at bass and sub-bass frequencies. The TQ-425 is equipped with a pole mount socket to enable QLight™ series mid-high loudspeakers to be used at an optimum height above the subwoofer.

TQ-115

The TQ-115 is a front loaded, single neodymium 15" vented subwoofer designed to combine with QLight™ series enclosures to give a high quality, full range sound reinforcement system ideally suited to all corporate, industrial, theatre and audio visual applications. When used with the LMS-D6 digital crossover it will reproduce high sound pressure levels at bass and sub-bass frequencies. The TQ-115 is equipped with a pole mount socket to enable QLight™ series mid-high loudspeakers to be used at an optimum height above the subwoofer.

SYSTEM REQUIREMENTS

QLight™ series passive loudspeaker enclosures require only one amplifier channel for correct operation, the frequency splitting between the low frequency driver and the high frequency driver being accomplished by the internal passive crossover network built into each enclosure. If subwoofer enclosures are used as part of a bi-amplified system in conjunction with QLight™ series 2-way enclosures to extend low frequency response, additional amplifier channels and external electronic crossovers will be required. The Turbosound LMS-D6 and LMS-4 digital loudspeaker management systems are recommended for this purpose, as well as other professional quality digital controllers.

Bi-amplified loudspeaker enclosures require the use of one amplifier channel per frequency band for correct operation. Frequency splitting between the low frequency driver, and the mid and high frequency section drivers is accomplished by an external electronic crossover; while frequency splitting between the mid frequency driver and the high frequency driver in 3-way models (TQ-445) is handled by an internal passive crossover.

Dedicated subwoofer enclosures require an additional amplifier channel when used as part of an extended frequency system. Frequency splitting between it and a QLight™ series mid-high enclosure is accomplished by an external crossover. Turbosound digital loudspeaker management systems are recommended for this purpose.

Amplifier considerations

Turbosound speaker enclosures should be driven by high quality power amplifiers designed for true professional use. Such amplifiers will have balanced inputs, DC and RF fault protection, and well designed cooling systems for reliability. Turbosound power amplifiers such as the T-45 and T-25 are recommended for this purpose.

The program power listed in the loudspeaker's technical specification is the best guide to the size of amplifier required for general purpose applications. The amplifier should therefore be capable of delivering long term broadband power equal to the loudspeaker's program power rating at the loudspeaker's stated nominal impedance. This approach allows sufficient headroom to generate good dynamic range.

RECOMMENDED AMPLIFIER POWER RATINGS:

The amplifier's rated r.m.s. continuous power output (20Hz – 20kHz, per channel) should be equal to the program power handling of the loudspeaker at its nominal impedance.

In general, the more powerful the amplifier, the better it will sound, provided that it is not driven into sustained clipping. It should be understood that overdriving an insufficiently powered amplifier is more likely to cause loudspeaker damage – the total energy in a heavily clipped signal is far higher than in an unclipped signal – than operating a more powerful amplifier within its ratings.

One loudspeaker management system can be used to feed several amplifiers as long as all the amplifiers are the same (or have the same gain ratings). More than one loudspeaker management system may be required if the amplifiers are of different gain or type. Please contact your dealer if you require help in this area.

Equalisation

QLight™ series enclosures are designed to provide smooth and even frequency response. They do not need excessive amounts of external equalisation to overcome the sonic deficiencies often found in many lesser designs.

Should an extended frequency response be required at more than moderate sound pressure levels, the use of complementary Turbosound subwoofer enclosures is strongly recommended.

In order to compensate for the room acoustics, QLight™ series enclosures require only minimal equalisation. As in any system, over-equalisation introduces phase shifts, distortion and a reduction in headroom, usually causing more problems than it cures. Under most circumstances a 1/3 or 1/2 octave graphic equaliser will generally be adequate, with the fader settings applied smoothly and as little as possible for the required room compensation. Most rooms will have resonances that will be excited at particular frequencies needing some cut to help tame the sound. These problems are most pronounced at the lower frequencies where loudspeakers generally exhibit very little directional control. If you find that the system needs a lot of boost at lower frequencies you may need additional sub-bass units. It is good practice to use as little equalisation as possible, aiming to cut frequencies rather than adding large amounts of boost.

Dispersion

QLight™ series loudspeakers fall broadly into two categories of dispersion pattern: wide and medium. While a wide horizontal coverage pattern of approximately 80° to 100° is appropriate for a majority of small to medium venues, one of the design features of the TQ-445 is a tightly controlled 60° horizontal by 40° vertical dispersion pattern at mid and high frequencies. This gives many user advantages and eases placement decisions, being essentially a point and shoot system. The more focused directivity results in greater projection capabilities, making the TQ-445 very suitable for theatre and small auditorium applications. Remember that a 60° horizontal polar pattern equals an angle of 30° either side of the centre line at which the sound pressure level is

6dB down with respect to centre, (averaged over the whole frequency range of the loudspeaker).

Converging Elliptical Waveguide™

A design feature of the TQ-308, TQ-310 and TQ-315 is the Converging Elliptical Waveguide™ (CEW™), available in two directivity patterns: 100° x 60° and 80° x 50°. This gives many user advantages. The comparatively short flare length allows the HF and LF components to be physically aligned in the cabinet, so ensuring coherent arrival at the listener's ear irrespective of distance from the loudspeaker. The elliptical format shapes the wavefront smoothly, and eliminates reflections in the throat area. Additionally this design does not suffer from the distortion typical of horns employing diffraction edges.

The waveguides can be removed and rotated through 90° in the cabinet, which allows the products to be installed in either vertical or horizontal formats while retaining the required coverage.

To rotate the horn, first remove the grille by undoing the countersunk Allen head screws which retain the grille from the sides of the cabinets. Remove the four screws holding the horn flange in place. Lift the horn and driver assembly out, rotate it through 90° and replace the fixing screws. Replace the grille.

MOUNTING AND FIXING

Rigging Hardware

A versatile range of mounting hardware is available that allows enclosures to be used in a variety of ways, in either mobile applications or permanent installations.

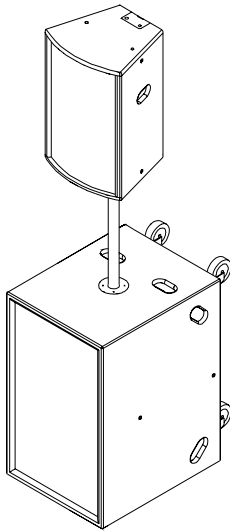

A top hat stand type fitting is fitted to the base of QLight™ series full range and mid-high cabinets for use with 35mm diameter loudspeaker stands. A pole mount socket is also fitted to the top of the QLight™ sub-bass cabinets. This allows two enclosures to be used together as an extended frequency range system as shown here with the TQ-445 mounted above the TQ-425 on the optional 35mm diameter straight pole. This enables a minimum footprint for the system and ensures the correct vertical distance between cabinets.

Internal M10 threaded rigging points are provided in several locations on the cabinet – generally on the top, bottom, sides and back – enabling enclosures to be suspended quickly and inexpensively using optional M10 shoulder eyebolts.

Downward inclination of the enclosure can be adjusted using an additional rigging point on the rear of the cabinet. Note: these rigging points are intended to hang a single box only and must NOT be used to rig a second enclosure in a vertical column.

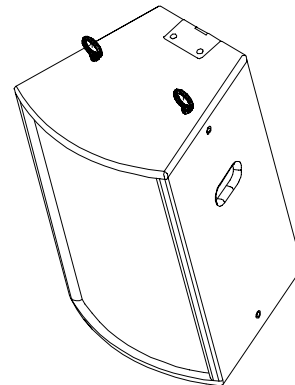

RT-767 ring type flying points. Rigging points are provided on the top and rear of the TQ-310 and TQ-315 for use with optional RT-767 rings, enabling cabinets to be rigged in permanent installations and for mobile applications. Downward inclination of the enclosure can be adjusted using the third RT-767 rigging point on the rear of the cabinet

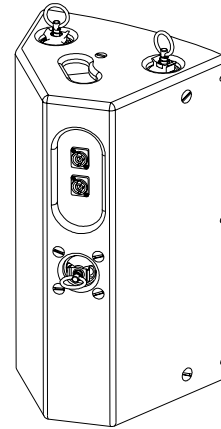

Swivel brackets provide a means of wall mounting some QLight™ series enclosures (TQ-308, TQ-310 and TQ-315) in a horizontal or vertical orientation. They are attached to the box using the integral pole mount fitting at the bottom and the M8 internal rigging point on the top of the cabinet. For applications requiring a horizontal format, an additional scaffold clamp assembly can be used with swivel brackets for attaching to lighting grids.

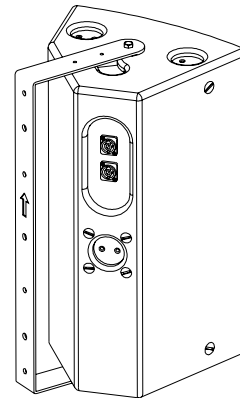
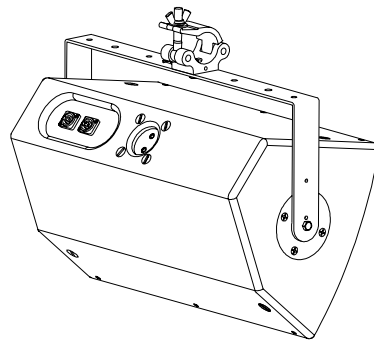

Wall brackets are available for most QLight™ series enclosures in different load ranges according to the weight of the cabinet. Two examples are shown below: the WB-10 wall bracket with a TQ-230 and the WB-20A with a TQ-310. Wall brackets can be dis-assembled to simplify installation and are supplied with the necessary fixings (except wall fixings). Remove the countersunk screws in the back of the box that correspond to the bolt hole pattern in the speaker plate, and attach it using the bolts provided with the hardware. Mount the wall plate in the desired position using suitable wall fixings. Locate the captive bolt on the speaker plate in the hole provided on the wall plate, position and angle the loudspeaker for optimum room coverage and tighten the nylock nuts.

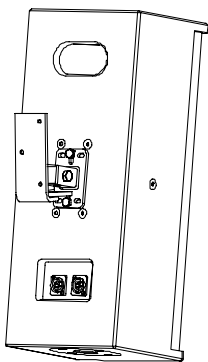

WB-10/TQ-230

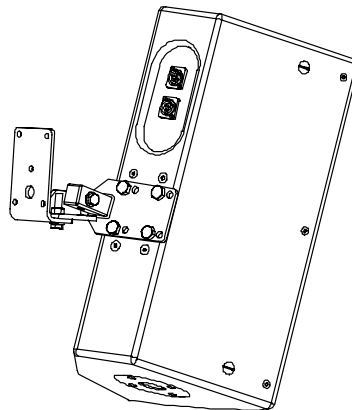

WB-55A/TQ-310

Ceiling brackets are available for the TQ-230, TQ-308, TQ-310 and TQ-315. As with Turbosound wall brackets, they can be dis-assembled to simplify installation and are supplied with the necessary fixings (except wall fixings). Remove the countersunk screws in the back of the box that correspond to the bolt hole pattern in the speaker plate, and attach it using the bolts provided with the hardware. Attach the ceiling plate using suitable fixings. Position and angle the loudspeaker for optimum room coverage and tighten the nylock nuts.

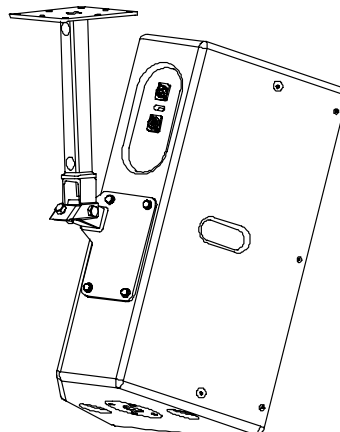

Side-mounted **flying strips** can be fitted to the sides of TQ-445 enclosures by removing the countersunk bolts on the top and sides of the cabinet and replacing them with the M10 bolts supplied with the hardware. Two flying strips are required for each enclosure; one attached to each side. This method offers a simple and cost effective way of flying single enclosures in permanent installations. Enclosures may also be arranged in a vertical column by coupling the flying strips together using QL-75 quicklinks or shackles. Turbosound flying strips are individually load tested. When used in this way the load is taken through the flying strips rather than through the woodwork of the enclosure.

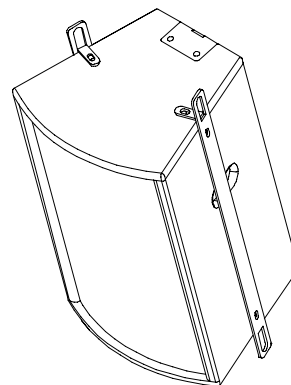

Side-mounted flying strips can be fitted to the sides of Qlight™ series subwoofer cabinets to enable subwoofer enclosures to be flown as part of a permanent installation. Two different lengths of flying strips are optionally available for flying the enclosure in either a vertical or horizontal orientation. These are fitted by removing the countersunk bolts on the top and sides of the cabinet and replacing them with the M10 bolts provided with the hardware. Two flying strips are required for each enclosure. This method offers a simple and cost effective method of flying single or multiple enclosures, with the load being taken through the steel strips rather than through the woodwork of the enclosure. Enclosures may be arranged in a vertical column if required by coupling the flying strips together using QL-75 quicklinks or shackles. Turbosound flying strips are load tested.

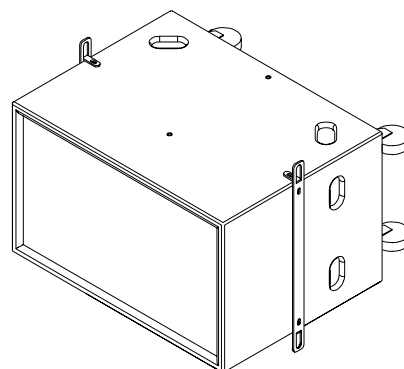
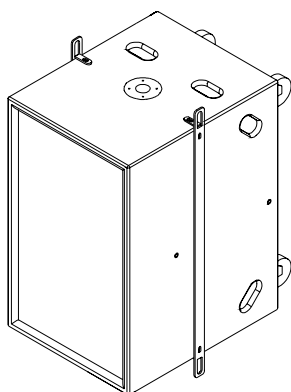

WARNING: Rigging eyebolts must not be used for flying this enclosure. You must use the optional Turbosound steel flying strips described above.

Single point mount options include a universal FB-12 flybar assembly for use with the TQ-445 and this enables the use of several different fixing methods. The illustration at right shows the FB-12 with three different methods of suspending the TQ-445 cabinet: a unilock fitting; a scaffold clamp; and a pick-up point adapter.

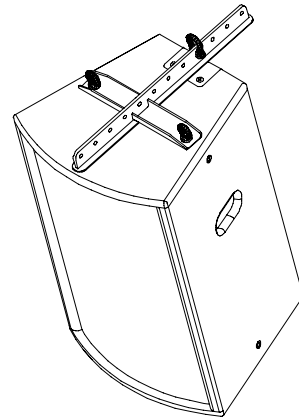

To attach the flybar first remove the threaded plastic plugs filling the rigging points on the top of the cabinet. Fit the flybar to the cabinet using the captive M10 shoulder eyebolts supplied with the flybar assembly. There are 12 attachment points equally spaced along the length of the spine of the flybar. Depending on which point is chosen for the given attachment system, a wide range of downward inclination angles can be achieved over a range of approximately 70 degrees. The design of the flybar even allows for upward angles, for example for coverage of balconies that are higher than the loudspeaker location.

The FB-12 flybar assembly comes supplied with a **U-6 Unilock** fitting, which provides a single attachment point. The point at which the Unilock is attached to the flybar determines the vertical angle of the loudspeaker as shown in the table following.



A **pick-up point adapter** offers a further single attachment point. This option provides fast adjustment of vertical angle. The point at which the eyebolt adapter is attached to the flybar determines the vertical angle of the loudspeaker as shown in the table following.

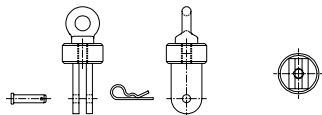

An **aluminium scaffold clamp** is attached to the fly bar by means of a simple clevis coupler. It is designed to rotate horizontally through 360° in order to enable accurate positioning of the loudspeaker. The point at which the scaffold clamp is attached to the fly bar determines the vertical angle of the loudspeaker as shown in the table following.

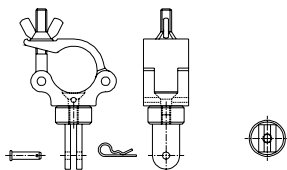

The following table gives the predicted downward angle of TQ-445 enclosures when using the FB-12 flybar.

Attachment position	Vertical angle (negative angle denotes upwards)
Hole number 1 (front of cabinet)	-29°
Hole number 2	-23°
Hole number 3	-17°
Hole number 4	-10°
Hole number 5	-3°
Hole number 6	4°
Hole number 7	11°
Hole number 8	18°
Hole number 9	24°
Hole number 10	30°
Hole number 11	35°
Hole number 12 (rear of cabinet)	40°

Flying frames enable Qlight™ series loudspeakers to be suspended from ceilings and lighting grids with virtually unlimited angle adjustment, including upward angles. These are available for the TQ-308, TQ-310, TQ-315 and TQ-445. To fit, remove the countersunk screws from the sides of the cabinet, position the frame and secure with the bolts provided. Angle the loudspeaker as required and tighten the handwheels.

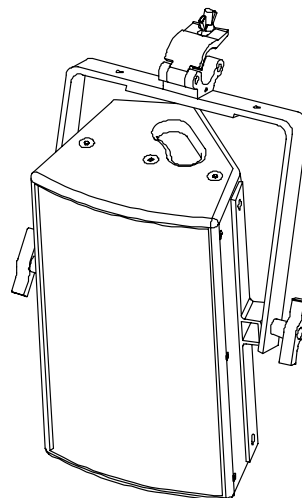

FH-308 flying frame

Summary of rigging options

	TQ-230	TQ-308	TQ-310	TQ-315	TQ-445	TQ-425	TQ-115
Eyebolts	M10	M10			M10	M10	M10
Rings			RT-767	RT-767			
Wall	WB-10	WB-20A	WB-20A	WB-55A			
Ceiling	CB-10	CB-20A	CB-20A	CB-55A			
Swivel		SB-308	SB-310				
Frame		FH-308	FH-310	FH-315	FH-445		
Pole	PB-55	PB-55	PB-55	PB-55	PB-55		
Strips					FS-445	FS-425	
Single point					FB-12		

Permanent installations

Any installation, whether temporary or permanent, must be securely attached to the structure of the building using chain, steel wires or web straps which are certified and load rated for the purpose. The combined weight of the sound system, its cables and the rigging system must be safely carried by the points at which attachment is made to the building or structure. Great care must be taken in selecting the attachment points and methods, being absolutely sure of the load carrying capacity of points chosen.

NOTE: The rigging of loudspeaker systems is an extremely serious matter with potentially lethal consequences should anything go wrong. It is of vital importance that you, or other people rigging

the system, are suitably qualified to do so and have a full understanding of all the factors involved with safety as a number one priority. Turbosound accepts no responsibility for any accident, damage or failure of any rigged system. This rigging information is specifically related to the requirements of QLight™ series enclosures only. For more detailed information on the whole topic of rigging various handbooks are available. If you are in any doubt contact your Turbosound dealer who will be able to refer you to an experienced rigging company.

Choosing the best location

When using any QLight™ system, certain room parameters will affect the resultant sound quality and coverage. For example, any boundary like a wall or floor will lift certain frequencies. If you are placing the unit in a corner then a lift at the bass end is to be expected and it may sound rather boomy. This can be compensated for moving the speaker or cutting low frequencies with a graphic equaliser.

When speakers are flown in free space then boundary effects are minimised. The result is a smooth frequency response without any boost at odd frequencies, but the bass end may appear subjectively light. In this case increase the sub-bass level to bring the low end up.

The relationship between sound pressure level and distance is an “inverse square law” so remember that every time the distance from the sound source is doubled the sound level decreases by 6dB. For every 3dB increase of speaker output you need a doubling of input power and you can work out the wattage input needed to give the required SPL levels at various distances from the loudspeaker(s).

MAINTENANCE

If any of the drive units should cease functioning and needs a replacement recone you are advised to remove the faulty unit from the cabinet and send it to a professional recone service authorised to recone Turbosound loudspeakers. This will ensure the continued high performance of your QLight™ series product.

TQ-230 - Removal of the drivers

The grille is secured in place with four flange head screws underneath the grille foam, at the top and bottom of the cabinet. To remove the grille, remove these screws and lift the grille away from the cabinet. The 5" woofers can now be removed from the cabinet by undoing the four screws holding the speaker in place. Disconnect the woofer(s) making note of the polarity for later reconnection.

To access the high frequency driver, remove the grille as above. Release the high frequency horn and driver assembly by undoing the four screws securing the horn flange to the baffle.

TQ-308/TQ-310/TQ-315 – Removal of the drivers

The grilles on these cabinets are held in place by three countersunk Allen head screws on each side, accessible from the sides of the cabinet. Remove these screws using the Allen key provided with your product and lift the grille away from the cabinet. The woofer retaining screws will now be visible and can be removed. Disconnect the driver(s) making note of the polarity for later reconnection.

With the grille removed you can now access the HF horn and driver assembly by unscrewing the four cap head screws securing the horn flange to the baffle. Disconnect the compression driver, making note of the polarity for later reconnection.

TQ-445 - Removal of the 12"/1" driver

Unscrew the eight countersunk screws from the two vertical battens that hold the protective grille in place. Be careful when removing the grille as it is under tension and may spring outwards when released. Set the battens, grille and fixing screws aside for later re-assembly.

Undo the eight M6 x 30mm Allen head bolts holding the driver in place and carefully pull it out and away from the cabinet. **WARNING** - this unit is heavy! You will notice that the 1" high frequency driver is attached to the back of the 12" low frequency driver by its screw adapter. Disconnect the cables from both HF and LF units and completely remove the driver assembly from the cabinet. Make a note of the driver polarity for later reconnection.

Separate the drive units by unscrewing the high frequency driver anti-clockwise and lift it away from the low frequency driver. Depending on which section needs servicing, the appropriate drive

unit should be returned to an authorised Turbosound service centre. To reinstate the drivers, simply reverse the above procedure making sure you observe the correct polarity when reconnecting the cables back into the terminals of the drive units.

TQ-115 - Removal of the 15" driver

Remove the countersunk Allen head screws retaining the grille from the cabinet sides and lift the grille away. Undo the M6 Allen head bolts holding the driver in place and carefully pull it out and away from the cabinet. Disconnect the cables from the drive unit and completely remove the driver from the cabinet. Make a note of the driver polarity for later reconnection. To reinstate the driver, simply reverse the above procedure making sure you observe the correct polarity.

TQ-425 – Removal of the 15" driver(s)

Unscrew the countersunk screws from the four battens that hold the protective grille in place. Set the battens, grille and fixing screws aside for later re-assembly. Undo the M6 Allen head bolts holding the driver(s) in place and carefully pull them out and away from the cabinet. Disconnect the cables from the drive unit and completely remove the driver from the cabinet. Make a note of the driver polarity for later reconnection. To reinstate the driver(s), simply reverse the above procedure making sure you observe the correct polarity when reconnecting the cables back into the terminals of the drive units.

TQ-445 - Removal of the midrange drive unit and horn assembly

Unscrew the countersunk screws from the two vertical battens holding the protective grille in place. Be careful when removing the grille as it is under tension and may spring outwards when released. Set the battens, grille and fixing screws aside for later re-assembly.

Remove the #6 x 1 1/2" countersunk woodscrews securing the rear panel of the cabinet, or the four bolts securing the amplifier module. The M10 bolt securing the midrange driver will now be accessible in a recess in the enclosure rear panel. Using a 17mm socket, unscrew the bolt and set aside for later re-assembly.

The midrange horn is secured through the mounting flange with four #10 x 1 1/2" countersunk wood screws. Unscrew these and lift out the horn and driver assembly. Disconnect the cables, making a note of the polarity, and carefully lift the driver clear.

For any other servicing requirements please contact your Turbosound dealer or authorised service centre.

APPENDIX A

Spares and accessories

CD-114	1" (25mm) HF compression driver	TQ-445
CD-110	1" (25mm) HF compression driver	TQ-308, TQ-310
CD-211	1.4" (35mm) HF compression driver	TQ-315
LS-1018	10" (254mm) LF loudspeaker	TQ-310
LS-1214	12" (305mm) LF loudspeaker	TQ-445
LS-1526	15" (381mm) LF loudspeaker	TQ-425, TQ-115
LS-1520	15" (381mm) LF loudspeaker	TQ-315
LS-50	5" (127mm) LF loudspeaker	TQ-230
LS-6505	6.5" (165mm) MF loudspeaker	TQ-445
LS-8091	8" (203mm) LF loudspeaker	TQ-308
RC-1018	Recone kit for LS-1018	TQ-310
RC-1214	Recone kit for LS-1214	TQ-445
RC-1526	Recone kit for LS-1526	TQ-425, TQ-115
RC-1520	Recone kit for LS-1520	TQ-315
RC-50	Recone kit for LS-50	TQ-230
RC-6505	Recone kit for LS-6505	TQ-445
RD-114	Replacement diaphragm	TQ-445
RD-110	Replacement diaphragm for CD-110	TQ-308, TQ-310
RD-211	Replacement diaphragm for CD-211	TQ-315
RD-25	Replacement diaphragm for TW-25	TQ-230
TW-25	1" compression driver	TQ-230

Flying accessories

BS-445	Biscuit	TQ-445
EB-10	M10 shoulder eyebolt	TQ-230/308/445/425/115
FB-12	Universal fly bar assembly	TQ-445
FF-445	Flying strips (2 required per enclosure)	TQ-445
FF-425L	Flying strips (2 required per enclosure) vertical	TQ-425
FF-425S	Flying strips (2 required per enclosure) horizontal	TQ-425
FH-308	Flying frame	TQ-230
FH-310	Flying frame	TQ-310
FH-315	Flying frame	TQ-315
FH-445	Flying frame	TQ-445
PP-445	Pick-up point adapter	TQ-445
RT-767	Ring type flypoints (set of 3)	TQ-310/315
TS-445	Tilting strap	TQ-445
U-6	Unilock	TQ-445

APPENDIX B: TECHNICAL SPECIFICATIONS

	TQ-230	TQ-308	TQ-310	TQ-315
Dimensions	528 x 210 x 200mm 20.8" x 8.3" x 7.9"	464 x 270 x 301mm 18.3" x 10.6" x 9.5"	525 x 319 x 277mm 20.7" x 12.5" x 10.9"	691 x 443 x 381mm 27.2" x 17.4" x 15"
Net weight	9.5 kgs 20.9 lbs	11.5 kgs 25.3 lbs	21 kgs 46.2 lbs	32.5 kgs 71.5 lbs
Power handling	125 watts rms 250 watts program	250 watts rms 500 watts program	350 watts rms 700 watts program	680 watts rms 1360 watts program
Sensitivity (1w @ 1m)	90dB	96dB	96dB	99dB
Frequency response (±4dB)	70Hz – 20kHz	68Hz – 20kHz	65Hz – 20kHz	55Hz – 20kHz
Nominal dispersion (@ -6dB points)	100°h x 60°v	100°h x 60°v	100°h x 60°v	80°h x 50°v
Maximum SPL (peak)	120dB	129dB	130dB	136dB
Connectors	(2) Neutrik Speakon NL4MP	(2) Neutrik Speakon NL4MP	(2) Neutrik Speakon NL4MP	(2) Neutrik Speakon NL4MP

	TQ-445	TQ-425	TQ-115
Dimensions	588 x 409 x 363mm 23.1" x 16.1" x 14.3"	836 x 511 x 632mm 32.9" x 20.1" x 24.9"	559 x 450 x 578mm 22" x 17.7" x 22.8"
Net weight	30 kgs 66 lbs	54 kgs 118.8 lbs	30.1 kgs 66.2 lbs
Power handling	LF: 600watts rms 1200 watts program MF/HF: 300 watts rms 600 watts program	800 watts rms 1600 watts program	400 watts rms 800 watts program
Sensitivity (1w @ 1m)	103dB	100dB	96dB
Frequency response (±4dB)	75Hz – 20kHz	55Hz – 200Hz	70Hz – 200Hz
Nominal dispersion (@ -6dB points)	60°h x 40°v	n/a	n/a
Maximum SPL	129dB	130dB	136dB
Connectors	(2) Neutrik Speakon NL4MP	(2) Neutrik Speakon NL4MP	(2) Neutrik Speakon NL4MP

Due to continuing product improvement the above specifications are subject to change.

APPENDIX C: WARRANTY

Limited Warranty

This Turbosound loudspeaker product is warranted to the original end-user purchaser and all subsequent owners for a period of two (2) years for loudspeakers from the original date of purchase.

Warranty Coverage

Warranty coverage includes defects in materials and workmanship. It does not include:

- damage caused by accident, misuse, abuse, neglect or modification by any person other than an authorised Turbosound representative,
- damage caused by failure to operate the product in accordance with the instructions contained in the user manual,
- damage occurring during shipment in transit,
- claims based on any misrepresentation by the seller,
- products which do not have the original components as specified in the product engineering information,
- products on which the serial number has been removed or defaced.

Shipping

Should any fault develop with a component of your Turbosound system, please return the product, freight pre-paid, in its original packing carton, along with proof of purchase such as the original bill of sale or receipted invoice, and a description of the suspected fault to Turbosound Ltd. (Att: Customer Service), Star Road, Partridge Green, West Sussex RH13 8RY, England, or your local authorised Turbosound representative. The product serial number must be quoted in all correspondence relating to the claim. Insurance is recommended, as Turbosound or its representatives are not liable for loss or damage in transit. Turbosound will pay for return freight costs should repairs be covered under warranty.

Incidental and consequential damages

Turbosound's liability is limited to the repair or replacement, at our option, of any defective product, and shall not be liable for any incidental and consequential damages including, without limitation, injury to persons or property or loss of use.

Limitation of implied warranties

All implied warranties, including warranties of merchantability and fitness for a particular purpose, are limited in duration to the length of this warranty.

This warranty is in addition to, and in no way detracts from, your statutory rights as a consumer. No other warranty is expressed or implied.

Please record your purchase information below for future reference:

Dealer Name

Dealer Address

.....

.....

Post / Zip Code

Dealer telephone / fax

Invoice number

Date of purchase

Unit serial number

Turbosound Ltd.
Star Road, Partridge Green
West Sussex RH13 8RY England
Tel: +44 (0)1403 711447 Fax: +44 (0)1403 710155
web: www.turbosound.com

Free Manuals Download Website

<http://myh66.com>

<http://usermanuals.us>

<http://www.somanuals.com>

<http://www.4manuals.cc>

<http://www.manual-lib.com>

<http://www.404manual.com>

<http://www.luxmanual.com>

<http://aubethermostatmanual.com>

Golf course search by state

<http://golfingnear.com>

Email search by domain

<http://emailbydomain.com>

Auto manuals search

<http://auto.somanuals.com>

TV manuals search

<http://tv.somanuals.com>