

### Models covered by this Quick Start Guide

TCS-61/106, TCS-122/XX(DP), TCS-152/XX(DP), TCS-1561/74(DP), TCS-B15A(DP), TCS-B15B(DP), TCS-B218(DP)

Thank you for choosing a TURBOSOUND loudspeaker product for your application. If you would like further information about this or any other TURBOSOUND product, please contact us by phone at +44 (0)1403 711447 or visit our website at [www.turbosound.com](http://www.turbosound.com) where you will find a detailed user guide on these and other products.

### Unpacking the Loudspeaker

After unpacking the unit please check carefully for damage. If damage is found, please notify your supplier at once. You, the consignee, must instigate any claim. Please retain all packaging in case of future re-shipment.

### System Requirements – Passive, Bi-amped and Tri-amped Loudspeakers

The TCS-61 two-way loudspeaker operates as a passive system and requires only one amplifier channel for correct operation; the frequency splitting between the LF driver and the HF driver being accomplished by the internal passive crossover network built into each enclosure. It is equipped with a Speakon NL4 wired in parallel with a 4-way barrier strip connector, providing input and loop-through connections to additional TCS series loudspeakers.

The TCS-122 and TCS-152 will operate either in bi-amp mode; or in one of three passive modes in which minor voicing adjustments are made within the crossover network depending on the supplied HF horn option, as indicated by the position of the internal jumper on the crossover setup section of the connector panel shown here (all models are shipped by default in passive mode). They are each equipped with a Neutrik Speakon NL4 connector wired in parallel with a 4-way barrier strip. The TCS-122 and TCS-152 two-way loudspeakers in bi-amped mode require two amplifier channels and an external electronic crossover.

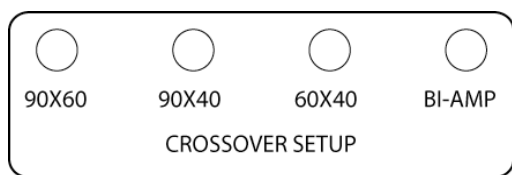

The TCS-1561 is a switchable bi-amp/tri-amp loudspeaker (shipped as bi-amp) requiring either two or three amplifier channels, together with an electronic crossover. All connections are provided on two parallel-linked NL8 connectors.

To avoid wasting amplifier power you should use heavy-duty speaker cable with a minimum wire size of 12 gauge (1.5mm<sup>2</sup>), and preferably 10 gauge (2.5mm<sup>2</sup>) for longer runs. For extreme cable lengths be aware of cable impedance and resistive losses. Always observe the correct polarity as shown.

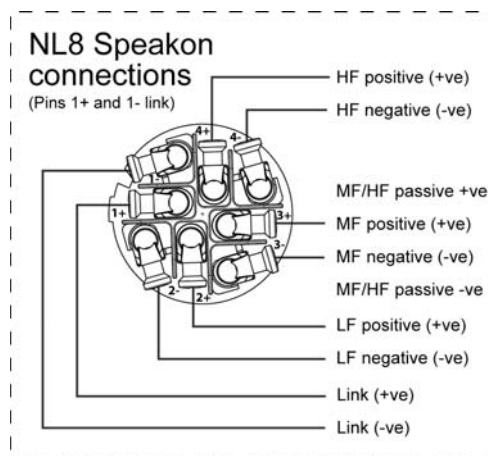
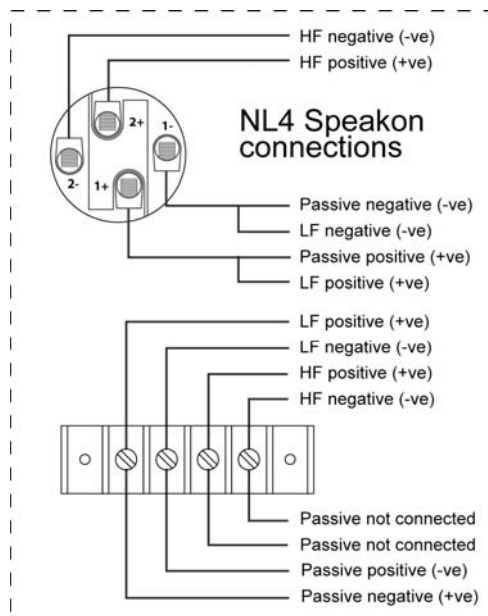

## Amplifier considerations

TCS series speaker enclosures should be driven by high quality power amplifiers designed for true professional use. Amplifiers should be capable of delivering long term broadband power **equal to the loudspeaker's program power rating at its stated nominal impedance**. The use of under-powered amplifiers must be avoided as heavily clipped signals can cause permanent loudspeaker damage.

Model	TCS-61/106	TCS-122/XX	TCS-152/XX	TCS-1561/74	TCS-B15A	TCS-B15B	TCS-B218
Impedance	8Ω	HF:8Ω, LF:8Ω	LF:8Ω, HF:8Ω	HF:16Ω, MF:16Ω, LF:8Ω Passive:12Ω	8Ω	8Ω	4Ω
Amplifier power	350w	HF:200w LF:1000w	HF:200w LF:1000w	HF:100w MF:200w LF:1000w	1000w	1000w	2400w

## System controllers with bi-amplified and tri-amped systems

These systems must be used with Turbosound LMS-D24 or LMS-D26 controllers, since these provide vital operating and system security features. If you do not have a controller, **DO NOT USE** the loudspeaker without one; please contact your Turbosound dealer for further details.

Turbosound LMS-D2X controllers provide factory presets for all TCS systems, as well as additional user program slots.

1. Power up the controller(s) and associated power amplifiers.
2. Press **RECALL** to select the appropriate program from the preset menu using the 'A' ROTARY ENCODER.
3. Press **RECALL** again to accept the preset. The controller will un-mute and is then ready for use.

## Self-powered loudspeakers

Powered TCS loudspeakers feature very efficient integrated Class D amplifiers and control electronics modules, providing a completely self-contained professional sound system. The XLR inputs and outputs are electronically balanced and are wired pin 2 hot, pin 3 cold, pin 1 ground. Amplifiers will operate over a range of mains input voltages from 100V to 240V AC without adjustment.

**Connect the mains power** using the supplied Powercon mains connector.

**Connect the signal input** from a professional mixing console to the female XLR input, and link out to additional powered loudspeakers from the male XLR output if required

1. **Power up the loudspeaker.** After a short self-test routine the loudspeaker will un-mute; it is now ready for use.

## Networking capability

TCS systems are designed to offer control and monitoring of system parameters over a BvNet network in real time using a PC and TurboDrive™ software. LMS-D2X controllers are equipped with network cards and are pre-configured with factory programs for all TCS series models. Self-powered TCS loudspeakers have built-in network functionality on RJ45 connectors.

**Download the TurboDrive™ software** from the supplied CD or from <http://www.turbosound.com> and follow the installation instructions.

**Install the drivers.** If connecting via RS232 there is no need to install drivers. If connecting via USB install the USB drivers which can be found on the CD that came with your Linea Research USB interface.

**Networking multiple devices to a PC:** BvNet is the method of connecting multiple devices – these can be controllers and/or powered TCS loudspeakers – and this is done with the Linea Research USB & RS232 Interface (available from Turbosound). The interface enables devices to be connected to a PC either using RS232 or using USB. EIA485 is the network protocol among the networked devices and is carried over CAT5-type cables. Minimum system requirements are: PC with Pentium processor, Windows NT, 2000, XP, or Vista, CD ROM drive or internet access, RS232 or USB port.

**RS232:** Connect your computer to the BvNet interface using a standard 9-pin serial cable. External power is required for RS232 operation and this should be supplied by the Linea Research Accessory Power Supply.

**USB:** Connect your computer to the BvNet interface using a USB Type A to USB Type B cable. External power is not required when using USB.

Connect networked devices via RJ45 CAT5 cables.

Launch the TurboDrive™ software.

Application Authorisation: TurboDrive™ prompts for an **Authorisation Code** on the first launch which is PJLUWZ.

Select the **COM port** from Network > Com Port.

Click the **Online** toolbar button.

Click on one of the devices that appear in the tree view to **Launch the panel**.

When the progress bar indicates *ready*, **adjust** the controls as required.

Please refer to the TurboDrive™ User Guide for further information on networking.

**Mounting and Fixing**

TCS series cabinets are designed with multiple internal rigging points to suit many possible mounting methods in permanent installations. All cabinets can be simply suspended using optional M8 or M10 shoulder eyebolts coupled to the internal rigging points provided. Remove the appropriate countersunk screws and replace them with eyebolts, which must have a thread length of at least 18mm. Use the rear rigging point to angle the cabinet for optimum room coverage. Cabinets may be hung upside down if required. Turbosound WB-20, WB-55 and CB-55 wall and ceiling brackets are optionally available for TCS series cabinets, and these are also compatible with OmniMount™ wall and ceiling brackets which use 60mm x 60mm hole spacing. Some examples of rigging options are shown below.

Model	Wall	Ceiling	Downfill	Vertical Array	Horizontal Array	Eyebolts
TCS-61	WB-20	CB-55	SB-61 ICC-61			EB-8
TCS-122	WB-55	CB-55		ICC-2V	FP-1 ICC-2H	EB-10/40
TCS-152	WB-55	CB-55		ICC-2V	FP-1 ICC-2H	EB-10/40
TCS-1561				ICC-2V		EB-10/40
TCS-B15A					FP-2 ICC-4H	EB-10/40
TCS-B15B					FP-2 ICC-4H	EB-10/40
TCS-B218						EB-10/40

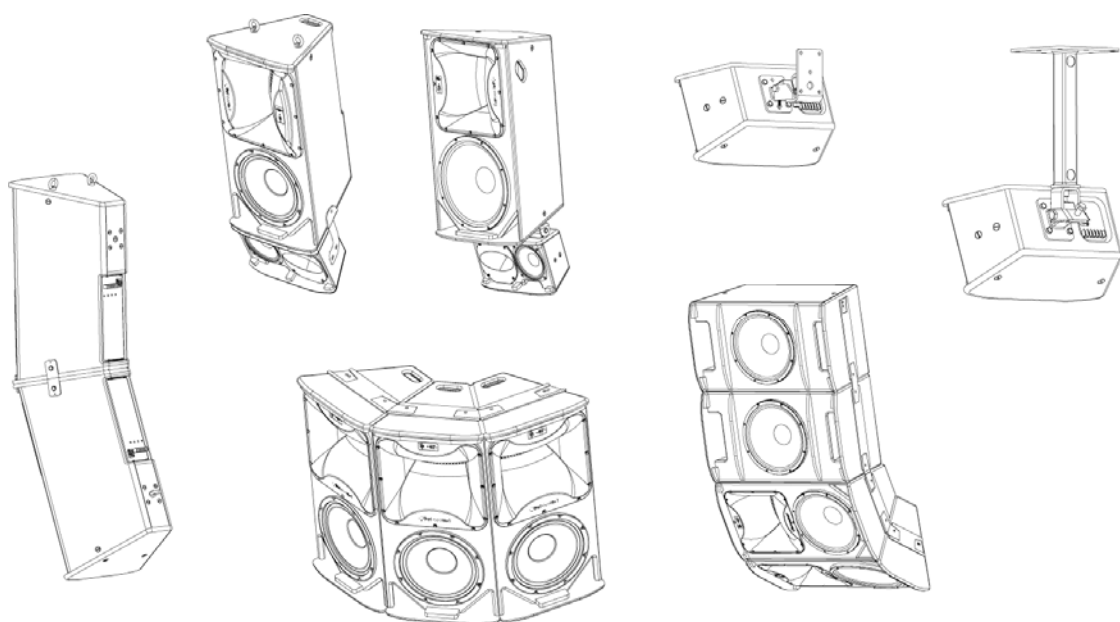

## Wall and ceiling brackets

To install a loudspeaker using Turbosound wall and ceiling brackets, first separate the brackets into their wall/ceiling plate and speaker plate component parts. Remove the countersunk bolts on the rear panel of the cabinet. Attach the speaker plate to the cabinet with the bolts supplied. Fix the wall/ceiling plate in the venue using appropriate fixings (not supplied). Lift the loudspeaker on to the wall plate and re-assemble the bracket parts, adjust the vertical angle and tighten all bolts.

## Downfill Applications

The TCS-61 can be tight-packed underneath TCS-122 or TCS-152 cabinets to provide downfill coverage using the SB-61 swivel bracket. First disassemble the swivel bracket into its component parts. Remove the countersunk bolts from the bottom panel of the TCS-122/152 cabinet and fit the section with the elongated holes using the fixings supplied. Remove the countersunk bolts on the top panel and fit the swivel bracket using the supplied fixings. Re-assemble the swivel bracket, angle as appropriate and tighten all fixings.

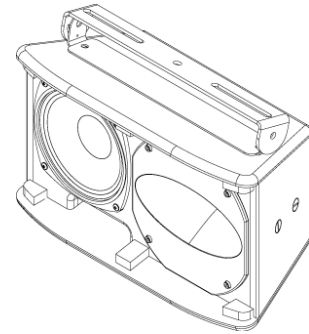

To use the SB-61 in a ceiling-mount application, separate the component parts as above, fix the top section to the ceiling with appropriate fixings (not supplied). Fit the other half to the cabinet, re-assemble the bracket, angle as appropriate and tighten all fixings.

## Vertical Arrays

An array of two or more cabinets requires the use of flyplates and inter-cabinet couplers, which are assembled together in a 'daisy chain' fashion to build up the required array. These are supplied as kits including appropriate fixings:

- 07G0335 FP-1 KIT**      kit of two FP-1 flyplates (one left, one right) for TCS-122 or TCS-152 mid/highs
- 07G0340 FP-2 KIT**      kit of two FP-2 flyplates (one left, one right) for TCS-B15A or TCS-B15B subs

**IMPORTANT NOTE:** The rigging of a flown sound system may be dangerous unless undertaken by qualified personnel with the required experience and certification to perform the necessary tasks. Fixing of hanging points in a roof should always be carried out by a professional rigger and in accordance with the local rules of the venue. Walls, floors or ceilings must be capable of safely and securely supporting the actual load. The rigging accessory used must be safely and securely fixed both to the loudspeaker and to the wall, floor or ceiling.

When mounting rigging components on walls, floors or ceilings, ensure that all fixings and fasteners used are of an appropriate size and load rating. Wall and ceiling claddings, and the construction and composition of walls and ceilings, all need to be taken into account when determining whether a particular fixing arrangement can be safely employed for a particular load. Cavity plugs or other specialist fixings, if required, must be of an appropriate type, and must be fitted and used in accordance with the maker's instructions.

## Rotating the HF horn pattern

The high frequency horn in all TCS-122 and TCS-152 models can be rotated through 90° in order to swap the horizontal and vertical dispersion patterns, particularly useful when assembling clusters or for example to retain the original dispersion when the cabinet is installed in a horizontal orientation.

1. Place the cabinet on its back on a suitable work surface. Remove the four pan-head posidrive screws that hold the grille in place and set the grille aside (fig 1).
2. Remove the bass driver and horn fixings screws (fig 2).
3. Disconnect and remove the bass driver, making a note of the polarity for later reconnection (fig 3).



4. Loosen the two wing nuts securing the hf driver retaining brace and lift out the horn and compression driver assembly (fig 4).
5. If required for servicing or replacement, disconnect the cables from the compression driver, making a note of the polarity for later reconnection (fig 5).
6. Rotate the horn to achieve the desired coverage pattern and replace it in the cabinet (fig 6).
7. If the compression driver has been removed, reconnect the cables observing the correct polarity (white cable to the +ve terminal, green/white cable to the -ve terminal) (fig 5).
8. Replace the horn and driver in the cabinet, making sure that the cable passes underneath the driver retainer and the compression driver locates squarely in the retaining brace (fig 6).
9. Tighten the wing nuts.
10. Replace the horn fixing screws and tighten.
11. Reconnect the bass driver, observing the correct polarity (brown cable to the red +ve terminal, blue cable to the black -ve terminal) and reinstate the driver in the cabinet (fig 3). Replace and tighten the driver fixing screws (fig 2).
12. Replace the grille (fig 1) and phase check the cabinet before use.

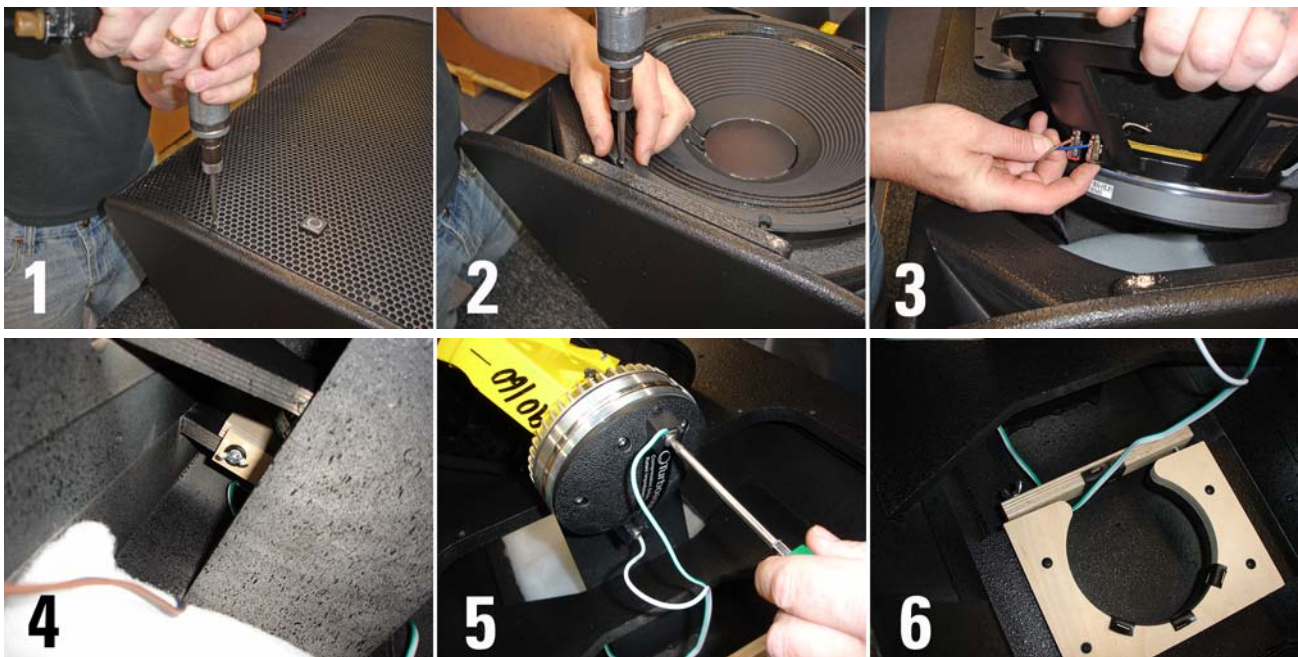

## Spares and Accessories

CD-115 / RD-115	Compression driver / diaphragm for TCS-61, TCS-1561
CD-214 / RD-214	Compression driver / diaphragm for TCS-122, TCS-152
LS-6508	6.5" low frequency loudspeaker for TCS-61
LS-6505 / RC-6505	6.5" mid frequency loudspeaker / recone kit for TCS-1561
LS-1222 / RC-1222	12" low frequency loudspeaker / recone kit for TCS-122
LS-1529 / RC-1529	15" low frequency loudspeaker / recone kit for TCS-152, TCS-1561, TCS-B15A, TCS-B15B
LS-1814 / RC-1814	18" low frequency loudspeaker / recone kit for TCS-B218
EB-10/40	Shoulder eyebolt 40mm

## LIMITED WARRANTY

This Turbosound loudspeaker product is warranted to the original end-user purchaser and all subsequent owners for a period of two (2) years, or one (1) year for electronics products, from the original date of purchase. Warranty coverage includes defects in materials and workmanship. It does not include:

- damage caused by accident, misuse, abuse, neglect or modification by any person other than an authorised Turbosound representative,
- damage caused by failure to operate the product in accordance with the instructions contained in the user manual,
- damage occurring during shipment in transit,
- claims based on any misrepresentation by the seller,
- products which do not have the original components as specified in the product engineering information,
- products on which the serial number has been removed or defaced.

Should any fault develop with a component of your Turbosound system, please return the product, freight pre-paid, in its original packing carton, along with proof of purchase such as the original bill of sale or receipted invoice, and a description of the suspected fault to your local authorised Turbosound representative. The product serial number must be quoted in all correspondence relating to the claim. Insurance is recommended, as Turbosound or its representatives are not liable for loss or damage in transit. Turbosound will pay for return freight costs should repairs be covered under warranty.

TCS series self-powered products comply with the following European Community standards: EN60065:2003 (Safety), EN66103-1:1996 and EN55103-2:1996. All products are CE marked in accordance with the relevant statutory requirements

**Turbosound Ltd**, Star Road, Partridge Green, West Sussex RH13 8RY, United Kingdom  
tel: +44(0)1403 711447 fax: +44 (0)1403 710155 [www.turbosound.com](http://www.turbosound.com)

TCS Quickstart version 1.2



## Free Manuals Download Website

<http://myh66.com>

<http://usermanuals.us>

<http://www.somanuals.com>

<http://www.4manuals.cc>

<http://www.manual-lib.com>

<http://www.404manual.com>

<http://www.luxmanual.com>

<http://aubethermostatmanual.com>

Golf course search by state

<http://golfingnear.com>

Email search by domain

<http://emailbydomain.com>

Auto manuals search

<http://auto.somanuals.com>

TV manuals search

<http://tv.somanuals.com>