



Hi-Res. B/W camera instruction manual

ADC 660N

ADC 660P

Version: Rev. A

tyco

Part Number 8200-0839-01

Notice

WARNING

To prevent fire or shock hazard, do not expose the unit to rain or moisture.



The symbol is intended to alert the user to the presence of important operating and maintenance (servicing) instructions in the literature accompanying the unit.



The symbol is intended to alert the user to the presence of uninsulated "dangerous voltage" within the product's enclosure that may be of sufficient magnitude to constitute a risk of electric shock to persons.

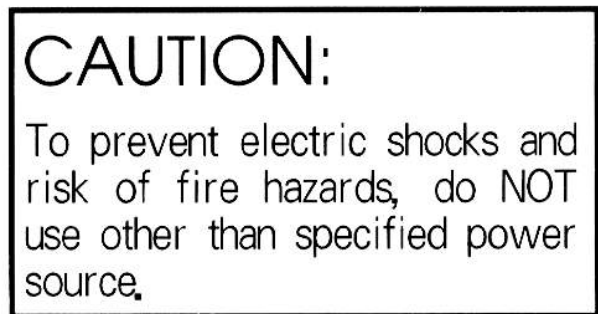

Warning

This equipment has been tested and found to comply with the limits for a Class A digital device, pursuant to part 15 of the FCC Rules. These limits are designed to provide reasonable protection against harmful interference when the equipment is operated in a commercial environment. This equipment generates, uses, and can radiate radio frequency energy and, if not installed and used in accordance with the instruction manual, may cause harmful interference to radio communications. Operation of this equipment in a residential area is likely to cause harmful interference, in which case the user will be required to correct the interference at his own expense.

Equipment Modification Caution

Equipment changes or modifications not expressly approved by Sensormatic Electronics Corporation, the party responsible for FCC compliance, could void the user's authority to operate the equipment and could create a hazardous condition.

This class A digital apparatus complies with Canadian ICES-003.

Cet appareil numérique de la classe A est conforme à la norme NMB-003 du Canada.

Caution

This installation should be made by a qualified service person and should conform to all local and national electrical and mechanical codes.

PRECAUTIONS

1. Do not attempt to disassemble the camera.

In order to prevent electric shock, do not remove screws or cover. There are no user-serviceable parts inside.

2. Do not expose the camera to rain or moisture, or try to operate it in wet areas.

Take immediate action if the camera becomes wet. Turn the power off and refer servicing to qualified service personnel. Moisture can damage the camera and also create a danger of electric shock.

3. Do not use strong or abrasive detergents when cleaning the camera body.

Use a dry cloth to clean the camera when dirty. In a case where the dirt is hard to remove, use a mild detergent and wipe gently.

4. Never point the camera toward the sun.

Whether the camera is used outdoors or not, never point it toward the sun.

Use caution when operating the camera in the vicinity of spot lights or other bright lights and light reflecting objects.

5. Do not operate the camera beyond its temperature, humidity or power source ratings.

Do not use the camera in an extreme environment where high temperature or high humidity exists. Use the camera under conditions where temperatures are between 14° F~122° F (-10° C~+50° C) and humidity is below 85%.

6. Use a 24V AC / 12V DC class 2 LPS supply only.

Hi-Res. B/W camera instruction manual

ADC 660N and ADC 660P

Copyright

©2007 Sensormatic Electronics Corporation.

Product specifications subject to change without notice. Certain product names mentioned herein may be trade names and/or registered trademarks of other companies.

Customer Service

Thank you for using American Dynamics products. We support our products through an extensive worldwide network of dealers. The dealer through whom you originally purchased this product is your point of contact if you need service or support. Our dealers are empowered to provide the very best in customer service and support. Dealers should contact American Dynamics at (800) 507-6268 or (561) 912-6259 or on the Web at www.americandynamics.net.

Hi-Res. B/W camera instruction manual

ADC 660N and ADC 660P

I. CONNECTORS AND CONTROLS	7
1. VIDEO OUTPUT CONNECTOR (BNC).....	7
2. POWER INPUT CONNECTOR (SCREW TERMINAL)	7
3. AUTO IRIS LENS CONNECTOR FOR VIDEO DRIVE LENS.....	8
4. AUTO IRIS LENS CONNECTOR FOR DC DRIVE LENS.....	8
5. BLC (BACKLIGHT COMPENSATION) ON/OFF SWITCH.....	9
6. ALC/ELC SELECT SWITCH (EE/ELC is ON; ALC/AI is OFF)	10
7. AGC ON/OFF SWITCH	11
8. INT/LL SWITCH (LL is ON; INT is OFF)	11
9. FL ON SWITCH (FLICKERLESS ON/OFF).....	11
10. V-PHASE ADJUSTMENT POTENTIOMETER.....	11
11. ALC LEVEL ADJUSTMENT POTENTIOMETER FOR DC DRIVE LENS.....	13
12. POWER INDICATOR LED	14
13. BACKFOCUS ADJUSTMENT SCREW	14
14. C MOUNT ADAPTOR RING	16
15. CCD DUST PROTECTIVE CAP	16
16. CAMERA MOUNT HOLE	16
17. CAMERA MOUNT BASE	16
II. EXAMPLES OF CONNECTIONS	17
1. SIMPLEST: ONE MONITOR SYSTEM WITH ONE CAMERA	17
2. ONE MONITOR SYSTEM WITH TWO OR MORE CAMERAS.....	17
III. DIMENSIONS.....	18
IV. SPECIFICATIONS	19

Hi-Res. B/W camera instruction manual

ADC 660N and ADC 660P

I. CONNECTORS AND CONTROLS

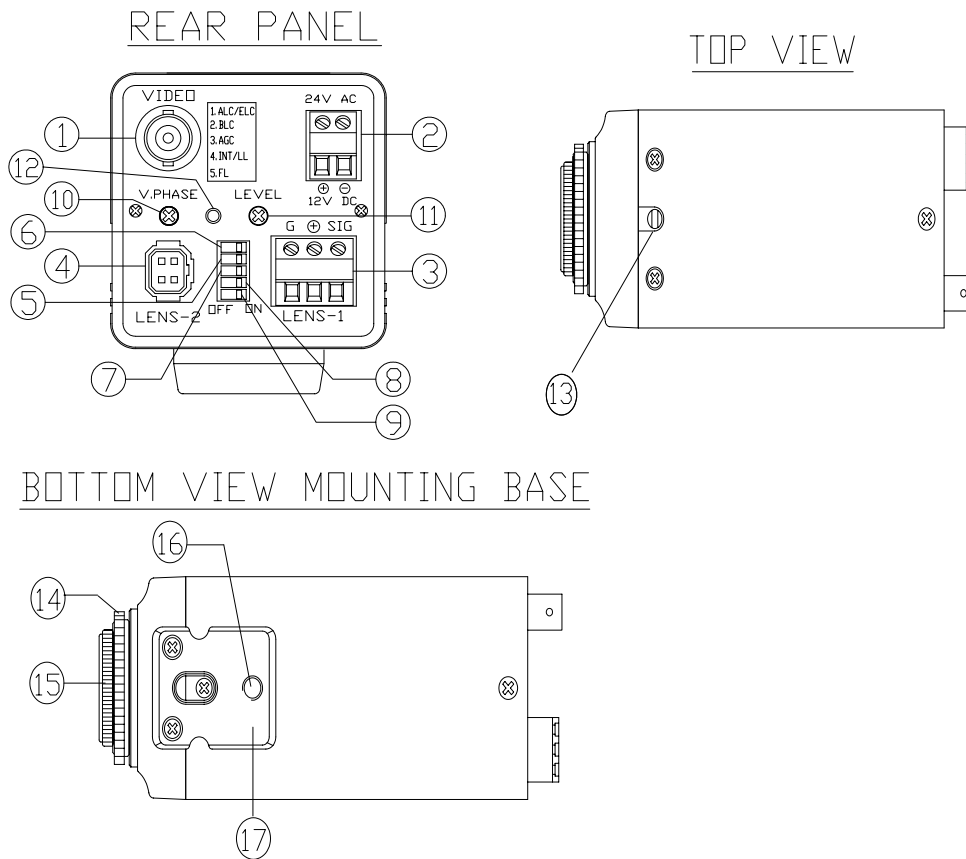

1. Video Output Connector (BNC)

1.0V p-p/75Ω composite video signal is provided at this connector.

2. Power Input Connector (screw terminal)

Hi-Res. B/W camera instruction manual

ADC 660N and ADC 660P

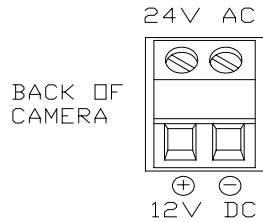

This terminal accepts 12 VDC or 24 VAC.

Power Requirement: Maximum 200 mA (12 VDC), Maximum 100 mA (24 VAC).

Recommended Power Supply: Minimum 500 mA (12 VDC); Minimum 300 mA (24 VAC).

Caution:

Use a 24V AC / 12V DC class 2 LPS supply only.

3. Auto Iris Lens Connector for VIDEO Drive Lens

This connector supplies 9 VDC power and video signal, without sync, for video-drive type Auto Iris lens.

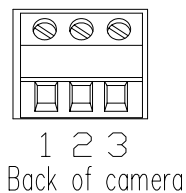

PIN	Signal
1	GROUND
2	POWER SUPPLY (9 VDC, 40mA)
3	VIDEO OUTPUT (0.7Vp-p without sync)

When using a VIDEO drive lens, the ALC/ELC DIP #1 must be set to the ALC (OFF) position.

4. Auto Iris Lens Connector for DC Drive Lens

This connector supplies the control signals to the DC drive Auto Iris lens.

Hi-Res. B/W camera instruction manual

ADC 660N and ADC 660P

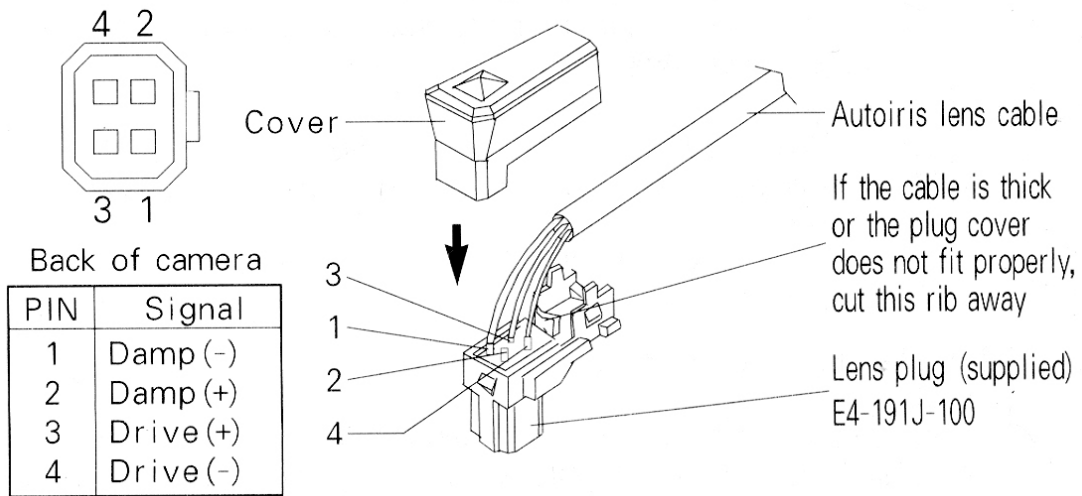

When using a DC drive lens, the ALC/ELC DIP #1 must be set to the ALC (OFF) position.

5. BLC (Backlight Compensation) ON/OFF Switch

If the subject you wish to view is too dim because of a bright background, set the BLC DIP switch #2 to ON to compensate for the bright background.

With BLC on, the background brightness may saturate in some cases. This function may not operate properly if the object is too small compared to the area of the background. This function can be used with either the linear shutter (EE or ELC mode) or an Auto Iris lens (AI lens or ALC mode).

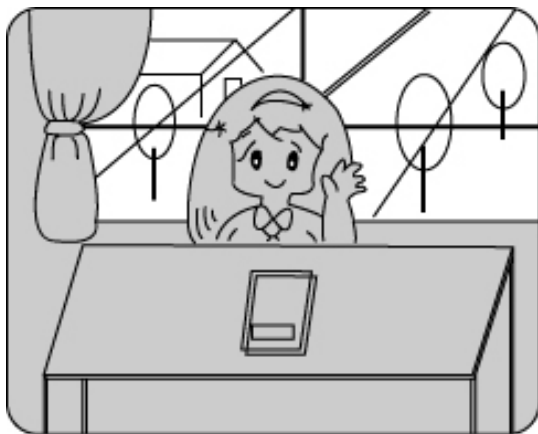

WITH BLC OFF

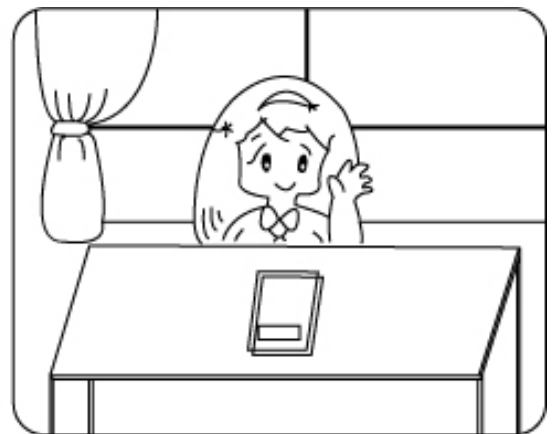

WITH BLC ON

Hi-Res. B/W camera instruction manual

ADC 660N and ADC 660P

6. ALC/ELC Select Switch (EE/ELC is ON; ALC/AI is OFF)

This switch is used to select EE (electronic exposure)/ELC (electronic light control) mode or AI (Auto Iris lens)/ALC (automatic light control) mode. DIP switch 1 is set to ON for EE/ELC and OFF for AI/ALC.

In the EE/ELC mode, a continuously variable electronic shutter is employed to automatically control the exposure time of the CCD image sensor according to the incoming light level. With this mode selected, a fixed or manual iris lens can be used instead of an Auto Iris lens. In the AI/ALC mode, the CCD shutter speed is fixed to 1/60 (1/50) sec, and the incoming light level is controlled by the Auto Iris lens. To use a video-drive type or the DC-drive type of Auto Iris lens, set this switch to the ALC position.

Cautions

- Under bright lighting conditions such as outdoors, use an Auto Iris lens because the EE/ELC control range is not wide enough under these conditions.
- Under certain unique lighting conditions, the following phenomena may appear:
 - ✓ Strong smear and/or blooming on highlighted objects such as spotlights or windows.
 - ✓ Noticeable flicker in the picture and/or color rendition variations. To avoid this, use an Auto Iris lens.
- When operating in EE/ELC mode with manual iris lens, the depth of field of the image may be less than that obtained by using an AI/ALC lens. Depth of field varies inversely with the iris opening. Thus, using this camera in EE/ELC mode with the manual iris lens fully opened may result in less depth of field and the distant objects in a picture may be seen out of focus.
- Fixed iris or manual iris lenses may be used with the linear shutter (EE/ELC mode) where the scene brightness varies over a limited range.
- Do not use the EE/ELC mode when an Auto Iris lens is installed.

Hi-Res. B/W camera instruction manual

ADC 660N and ADC 660P

7. AGC ON/OFF Switch

This switch is provided for the AGC circuit. The AGC circuit incorporated into the camera boosts the sensitivity automatically when the scene illumination is insufficient.

8. INT/LL Switch (LL is ON; INT is OFF)

This camera can operate independently, using its internal crystal-controlled sync generator, or it may be synchronized using line-locking.

To select one or the other of these sync modes, set the DIP switch on the rear panel to either INT or LL. Switch 4 is set to ON for LL and OFF for INT.

If line-lock is selected, all the cameras in the system must be adjusted to begin the video field scan at the same time. This is described in procedure ⑩.

9. FL ON Switch (Flickerless ON/OFF)

This function is only used in JAPAN. In order to use FL mode, set EE/AI switch to AI first and then FL ON/OFF switch to ON.

When the DIP switch on the rear panel is set to ON, the shutter speed is fixed at a rate of 1/100(120)(sec).

10. V-Phase Adjustment Potentiometer

This potentiometer is set full counter clockwise at the factory. If two or more cameras are connected to a switcher and the picture on the monitor rolls while switching from camera A to B, adjusting the vertical phase (V-phase) of the cameras will probably eliminate the rolling. If this adjustment is necessary, it should only be performed by a qualified technician. Before making any adjustment, confirm that cameras A and B are connected to the power supply with the same polarity.

To make an adjustment, follow the steps below.

Hi-Res. B/W camera instruction manual

ADC 660N and ADC 660P

1. While observing the video output signals from both cameras on an oscilloscope, turn camera A's V-phase control (on back of camera) until vertical sync from both cameras is in phase.
2. If camera A's adjustment range is insufficient, adjust camera B's V-phase control in the opposite direction to camera A until they are in phase.
3. If these adjustments do not bring vertical sync from both cameras in phase, recheck the polarity of the power supply connections.

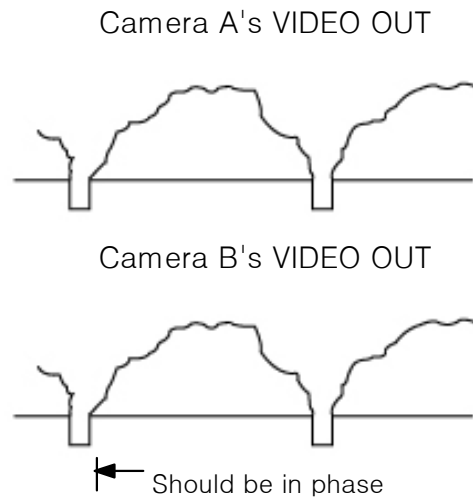

If an oscilloscope is not available, a less accurate adjustment can be made by observing the monitor and adjusting the V-phase control potentiometer until no roll occurs on the monitor when switching back and forth between cameras A and B.

Hi-Res. B/W camera instruction manual

ADC 660N and ADC 660P

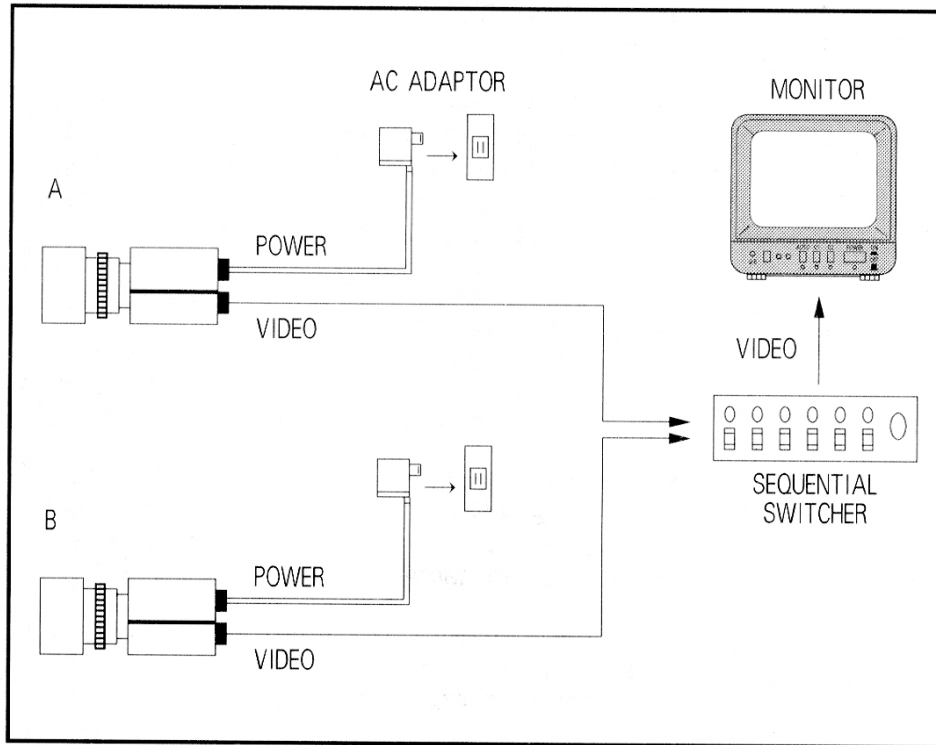

11. ALC Level Adjustment Potentiometer for DC Drive Lens

This potentiometer is used only if the camera is fitted with a DC drive Auto Iris lens. It is used to control the amount of light striking the CCD image sensor. Turn off AGC. With a brightly lit scene adjust LENS-IRIS control for a clean 1 VPP video level with no blooming. Turn AGC back on after adjustment is complete.

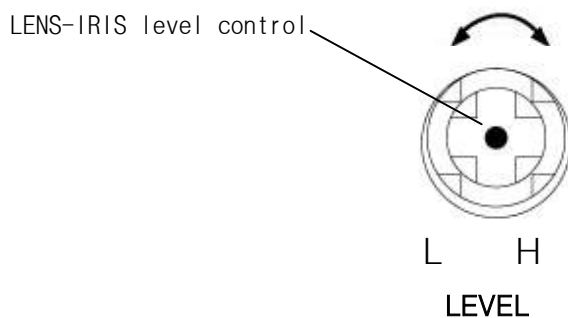

Hi-Res. B/W camera instruction manual

ADC 660N and ADC 660P

Monitor Screen	LEVEL Control Direction
To increase the brightness	Clockwise
To decrease the brightness	Counterclockwise

12. Power Indicator LED

This LED turns ON only when power is supplied properly and the DC-DC converter (or the regulator) inside the camera works properly.

13. Backfocus Adjustment Screw

This screw is used to position the CCD image sensor at the precise point of focus of the lens.

Backfocusing Fixed-Focal or Vari-Focal Length Lenses

Install a lens and connect the camera to a monitor and power supply as described in this manual.

Open the iris completely or just before there is blooming in the picture. If an Auto Iris lens is used, reduce the room lighting to use a neutral density filter to allow the lens to open completely. This gives the most accurate results.

Adjust the screw slowly until the sharpest picture is obtained. This completes the adjustment. The back-focus adjustment screw is held in place by friction, so there is no locking screw to tighten.

Backfocusing Zoom Lenses

Install a lens and connect the camera to a monitor and power supply.

Position the camera 10~30 feet (3~9 meters) from a flat vertical surface suitable for focusing. A newspaper works well as a focusing target.

Open the iris completely or just before there is blooming in the picture. If an Auto Iris lens is used, reduce the room lighting or use a neutral density filter to allow the lens to open completely. This gives the most accurate results.

1. Zoom the lens in to the maximum telephoto setting. Adjust the optical focus of the lens for the sharpest picture.
2. Zoom out to the maximum wide angle setting. If the picture is no longer in focus, readjust the back-focus screw to obtain the best focus possible.
3. Repeat steps 1 and 2 until the image remains sharp through the entire zoom range without having to make any focus adjustments.

This completes the adjustment. The back-focus adjustment screw is held in place by friction, so there is no locking screw.

Hi-Res. B/W camera instruction manual

ADC 660N and ADC 660P

TOP VIEW

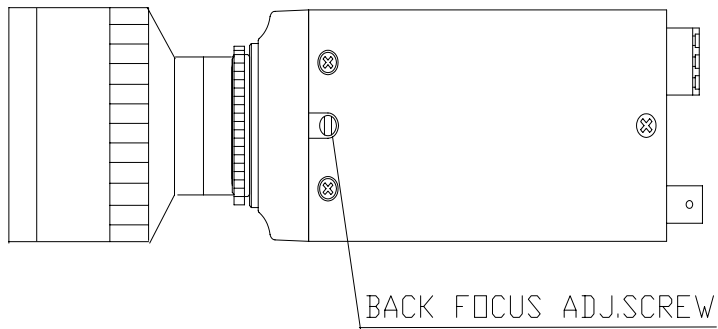

Hi-Res. B/W camera instruction manual

ADC 660N and ADC 660P

14. C Mount Adaptor Ring

The C-mount adaptor ring is used only if a C-mount lens is used on the camera. If a CS-mount lens is used, the adaptor is not necessary. To install the adaptor, first screw it into the lens mount opening on the camera. Then screw the C-mount lens into the adaptor.

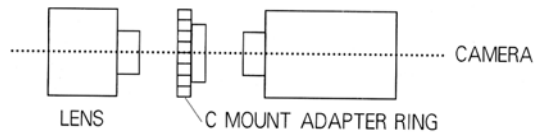

15. CCD Dust Protective Cap

Remove this cap before installing the lens.
Do not handle or leave the camera with cap open.

16. Camera Mount Hole

17. Camera Mount Base

Hi-Res. B/W camera instruction manual

ADC 660N and ADC 660P

II. EXAMPLES OF CONNECTIONS

1. Simplest: One monitor system with one camera

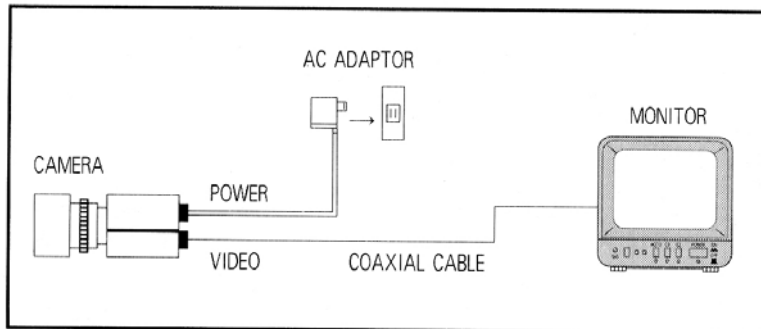

2. One monitor system with two or more cameras

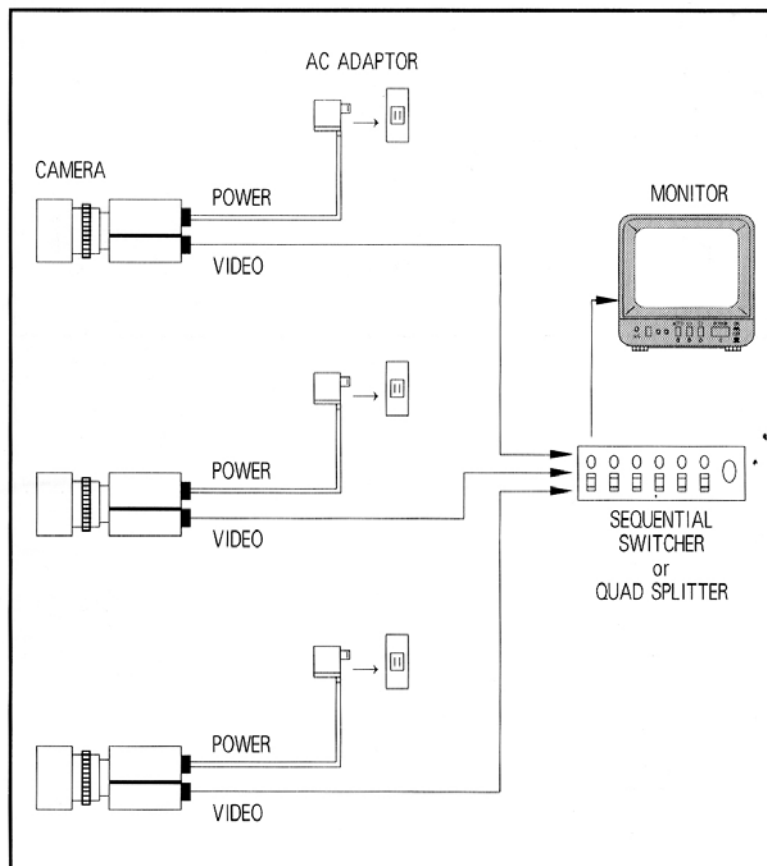

Hi-Res. B/W camera instruction manual

ADC 660N and ADC 660P

III. DIMENSIONS

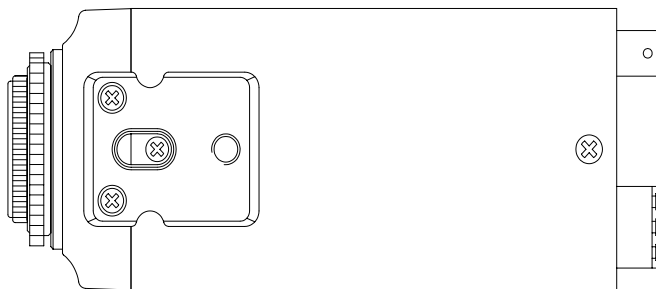
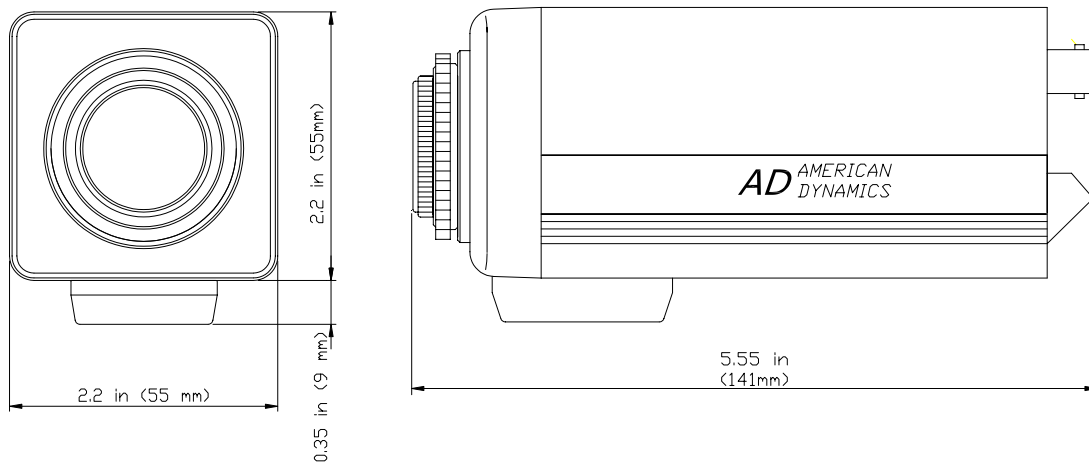

Hi-Res. B/W camera instruction manual

ADC 660N and ADC 660P

IV. SPECIFICATIONS

MODEL	ADC660N	ADC660P
TV SYSTEM	EIA	CCIR
EFFECTIVE PIXELS	768(H) X 494(V)	752(H) X 582(V)
IMAGE DEVICE	1/3" INTERLINE TRANSFER CCD	
SCANNING SYSTEM	2:1 INTERLACE	
SYNCHRONIZING SYSTEM	INTERNAL/LINE LOCK SELECTABLE	
HORIZONTAL RESOLUTION	580 TV LINE	
VIDEO OUTPUT LEVEL	1 V pp/75 ohm	
S/N RATIO	MORE THAN 50 dB (AGC OFF)	
MIN. ILLUMINATION (F1.2)	0.03 lux	
ELECTRONIC IRIS	1/60 ~ 1/100,000 SEC	1/50 ~ 1/100,000 SEC
LINE LOCK RANGE	60 Hz \pm 1 Hz	50 Hz \pm 1 Hz
BACKLIGHT COMPENSATION	ON/OFF SELECTABLE (CENTER ZONE WEIGHTED)	
BACKFOCUS ADJUSTMENT	FINE ADJUSTMENT WITH SELF LOCKING SYSTEM	
CAMERA MOUNT	1/4-20 UNC (TOP or BOTTOM SELECTABLE)	
LENS MOUNT	C- or CS-MOUNT (C-MOUNT ADAPTOR RING INCLUDED)	
AUTO IRIS SUPPORT	VIDEO-DRIVE TYPE WITH 3P TERMINAL DC-DRIVE TYPE WITH 4P SQUARE CONNECTOR	
POWER REQUIREMENT	12V DC \pm 20% 200mA MAX/24V AC \pm 20% 100mA MAX	
OPERATION CONDITION	14° F TO 122° F (-10°C~50°C) WITHIN 85% RELATIVE HUMIDITY	
NET WEIGHT (WITHOUT LENS)	APPROX. 0.9 lb (400 g)	
DIMENSIONS (W x H x L)	2.2 in. x 2.2 in. x 5.55 in. (55 x 55 x 141 mm)	

Free Manuals Download Website

<http://myh66.com>

<http://usermanuals.us>

<http://www.somanuals.com>

<http://www.4manuals.cc>

<http://www.manual-lib.com>

<http://www.404manual.com>

<http://www.luxmanual.com>

<http://aubethermostatmanual.com>

Golf course search by state

<http://golfingnear.com>

Email search by domain

<http://emailbydomain.com>

Auto manuals search

<http://auto.somanuals.com>

TV manuals search

<http://tv.somanuals.com>