

4100U Fire Indicator Panel

Fire Alarm System, Installation & Maintenance



**Australian
Installation &
Maintenance
Manual**

LT0350

Simplex

Copyrights and Trademarks

©2004 Tyco Safety Products Westminster, Westminister, MA 01441-0001 USA.

All specifications and other information shown were current as of document revision date, and are subject to change without notice.

Tyco, Simplex, the Simplex logo, MAPNET II, IDNet, TrueAlarm, SmartSync, WALKTEST, MINIPLEX, and TrueAlert are trademarks of Tyco International Services AG or its affiliates in the U.S. and/or other countries. VESDA is a trademark of Vision Products Pty Ltd.

Simplex fire alarm technology is protected by the following U.S. Patent Numbers:
TrueAlarm analog smoke detection: 5,155,468; 5,173,683 and 5,543,777. IDNet and MAPNET II addressable communications; 4,796,025. TrueAlert addressable notification; 6,313,744 and 6,426,697. SmartSync horn/strobe control; 6,281,789.

Approvals

Australian Standard AS4428.1

SSL Listing Number afp1682

Manufacture

The 4100U is a Fire Alarm manufactured by Tyco Safety Products for:

Tyco Services Fire & Safety
47 Gilby Road
Notting Hill
VIC 3168
AUSTRALIA

Phone : (03) 9538-7220

Fax : (03) 9538-7255

Product / Site

Name	
Serial #	
Manufacture Date	

Non-Disclosure Agreement

Tyco (THE COMPANY) and the User of this/these document(s) desire to share proprietary technical information concerning electronic systems.

For this reason the company is disclosing to the User information in the form of this/these document(s). In as much as the company considers this information to be proprietary and desires that it be maintained in confidence, it is hereby agreed by the User that such information shall be maintained in confidence by the User for a period of TEN YEARS after the issue date and only be used for the purpose for which it was supplied.

During this period, the User shall not divulge such information to any third party without the prior written consent of the company and shall take reasonable efforts to prevent any unauthorised disclosure by its employees. However, the User shall not be required to keep such information in confidence if it was in their possession prior to its receipt from the company; if it is or becomes public knowledge without the fault of the User; or the information becomes available on an unrestricted basis from a third party having a legal right to disclose such information.

The User's receipt and retention of this information constitutes acceptance of these terms.

This information is copyright and shall not be reproduced in any form whatsoever.

End User Liability Disclaimer

The 4100U Fire Indicator Panel provides a configuration programming facility, which may be accessed via a programming computer using a "dongle". Because this programming facility allows the user to define in detail the operation of the 4100U System being customised, changes may be made by the user that prevent this installation from meeting statutory requirements.

The Company, therefore cannot accept any responsibility as to the suitability of the functions generated by the user using this programming facility.

Model Number & Firmware Revision

This manual applies to product with the following:

Model number : 4100U

Firmware revision : 11.08 and on

Document

Document Name : LT0350 4100U Installation & Maintenance Manual

Cross Reference : 574-848 4100U Installation Manual (USA)

Issue : 1.0-G 14 May, 2004

Amendment Log

14 May, 2004 Issue 1.0.6 Original based on 574-848 Rev G

Cautions, Warnings, and Regulatory Information

READ AND SAVE THESE INSTRUCTIONS. Follow the instructions in this installation manual. These instructions must be followed to avoid damage to this product and associated equipment. Product operation and reliability depends upon proper installation.



DO NOT INSTALL ANY SIMPLEX® PRODUCT THAT APPEARS DAMAGED.

Upon unpacking your Simplex product, inspect the contents of the carton for shipping damage. If damage is apparent, immediately file a claim with the carrier and notify your Simplex product supplier.

SAFETY HAZARD - The 4100U CPU Card includes a lithium battery. There is danger of explosion if the battery is incorrectly replaced. Replace only with the same or equivalent type recommended by the manufacturer. Dispose of used batteries according to the manufacturer's instructions.



ELECTRICAL HAZARD - Disconnect electrical field power when making any internal adjustments or repairs. All repairs should be performed by a representative or authorized agent of your local Simplex product supplier.



STATIC HAZARD - Static electricity can damage components. Therefore, handle as follows:

- Ground yourself before opening or installing components (use the 553-484 Static Control Kit).
- Prior to installation, keep components wrapped in anti-static material at all times.



EYE SAFETY HAZARD - Under certain fiber optic application conditions, the optical output of this device may exceed eye safety limits. Do not use magnification (such as a microscope or other focusing equipment) when viewing the output of this device.



RADIO FREQUENCY ENERGY - This equipment generates, uses, and can radiate radio frequency energy and if not installed and used in accordance with the instruction manual, may cause interference to radio communications. It has been tested and found to comply with the limits defined in AS4428.0-1997 and Amendment 1 : 2002.

SYSTEM REACCEPTANCE TEST AFTER SOFTWARE CHANGES - To ensure proper system operation, this product must be tested in accordance with AS1670 after any programming operation or change in site-specific software. Reacceptance testing is required after any change, addition or deletion of system components, or after any modification, repair or adjustment to system hardware or wiring.

All components, circuits, system operations, or software functions, known to be affected by a change must be 100% tested. In addition, to ensure that other operations are not inadvertently affected, at least 10% of initiating devices that are not directly affected by the change, up to a maximum of 50 devices, should also be tested and proper system operation verified.

IMPORTANT: Verify 4100U System Programmer, Executive, and Slave Software compatibility when installing or replacing system components. Refer to Solution Bulletin SB01014 for compatibility information.

Table of Contents

Copyrights and Trademarks	i
Approvals	i
Manufacture	i
Product / Site	i
Non-Disclosure Agreement	ii
End User Liability Disclaimer	ii
Model Number & Firmware Revision	iii
Document	iii
Amendment Log	iii
Cautions, Warnings, and Regulatory Information	iv
Table of Contents	v
List of Figures	xiv
List of Tables	xv
Chapter 1 Introduction to the 4100U Fire Alarm System	1-1
Introduction	1-1
In this Chapter	1-1
System Configurations	1-2
Overview	1-2
Standalone Configuration	1-3
Overview	1-3
System Design	1-3
MINIPLEX Configuration	1-4
Overview	1-4
System Design	1-4
RUI Communication	1-5
Network Configuration	1-6
Overview	1-6
Hub and Star Configurations	1-6
Connecting Loops	1-7
System Design	1-7
Network Communication	1-7
4100 PIDs (Non-4100U)	1-8
Annunciation Modules	1-8
4100U Cabinet Part Identification Numbers (PIDs)	1-9
Overview	1-9
4100U Cabinets	1-9

4100U PIDs	1-9
Overview	1-9
Assemblies, Cards & Modules	1-9
Kits	1-10
Labels	1-10
Looms	1-10
Chapter 2 Installing 4100U FACP Components	2-1
Introduction	2-1
In this Chapter	2-1
Introduction to FACP (4100U)	2-2
Overview	2-2
CPU Bay	2-2
Master Motherboard	2-3
Master Controller Daughter Card	2-4
Master Controller Daughter Card LEDs.....	2-5
Operator Interface.....	2-6
Additional CPU Bay Modules	2-6
Expansion Bays	2-6
System Power Supply (SPS).....	2-7
System Power.....	2-8
The Power Distribution Interface (PDI).....	2-8
Step 1. Mounting Cabinets (4100U)	2-9
Overview	2-9
Step 2. Mounting Card Bays to Cabinets (4100U)	2-9
Overview	2-9
Step 3. Configuring Cards (4100U)	2-10
Overview	2-10
Master Motherboard Configuration	2-10
Master Controller Daughter Card Configuration	2-10
SPS Configuration	2-10
PDI Configuration	2-11
Configuring Other Cards.....	2-11
Step 4. Interconnecting Modules and Bays	2-11
Overview	2-11
Guidelines	2-11
Card Interconnections in the CPU Bay	2-12
Card Interconnections Within Expansion Bays	2-12
Basic Bay-To-Bay Interconnections	2-12
Connecting to Motherboards	2-13
Step 5. Installing Modules into Expansion Bays (4100U)	2-15
Overview	2-15
Placement Guidelines.....	2-15
Installing 4" X 5" Cards	2-18

Step 6. Installing LED/Switch Modules into Expansion Bays (4100U).....	2-20
Overview	2-20
The LED/Switch User Interface	2-21
LED/Switch Controller Card.....	2-21
LED/Switch Modules.....	2-22
Configuring the LED/Switch Controller Card	2-22
Activating the Communication Loss Feature	2-22
Mounting LED/Switch Modules to the Expansion Bay	2-23
Mounting the Controller Card Assembly	2-24
Changing Display Card LEDs	2-24
Interconnecting Cards.....	2-25
Wiring Instructions	2-26
 The Terminal Block Utility Module (4100U).....	 2-27
Overview	2-27
Mounting to the Electronics Bay	2-27

Chapter 3 Installing 4100 MINIPLEX Components (Non-4100U) 3-29

Introduction	3-29
In this Chapter	3-29
 Introduction to MINIPLEX Systems (Non-4100U)	 3-30
Overview	3-30
 MINIPLEX System Components (Non-4100U)	 3-32
Overview	3-32
The RUI Card.....	3-32
Transponder Cabinets	3-32
The Remote Interface Card (RIC)	3-33
 MINIPLEX System Guidelines (Non-4100U).....	 3-34
Overview	3-34
Guidelines	3-34
 Installing Modules into Cabinets (Non-4100U).....	 3-35
Overview	3-35
Guidelines	3-35
Installing the RUI Motherboard	3-35
Installing the RIC II Motherboard	3-36
Connecting the 733-525 Harness	3-37
 MINIPLEX Wiring (Non-4100U).....	 3-39
Overview	3-39
Wiring Configurations	3-39
Class A Wiring	3-39
Class B Wiring	3-39
Wiring Illustration	3-40

Chapter 4 Installing 4100U MINIPLEX Components 4-1

Introduction	4-1
In this Chapter	4-1
 Introduction to MINIPLEX Transponders (4100U).....	 4-2
Overview	4-2
Transponder Cabinets	4-2
Transponder Interface Cards (TICs).....	4-2
Basic TICs	4-2
The Local Mode TIC (Not currently available in Australia).....	4-3
TIC Illustrations.....	4-4

Local Mode Specifications.....	4-5
LEDs.....	4-6
Card Specifications.....	4-6
MINIPLEX System Guidelines (4100U).....	4-7
Overview.....	4-7
Guidelines.....	4-7
Configuring Cards (4100U).....	4-8
Overview.....	4-8
CPU Motherboard DIP Switch.....	4-8
TIC Configuration.....	4-8
Configuring Other Cards.....	4-8
TIC/Riser Mounting (4100U).....	4-9
Overview.....	4-9
Mounting Instructions.....	4-9
TIC/Motherboard Interconnections (4100U).....	4-10
RUI Wiring (4100U).....	4-11
Overview.....	4-11
Wiring Configurations.....	4-11
Chapter 5 Networking	5-1
Introduction.....	5-1
In this Chapter.....	5-1
Getting Started.....	5-2
Overview.....	5-2
Introduction to the 4100 Network Interface Card (NIC).....	5-3
Overview.....	5-3
Network Module Illustrations.....	5-4
NIC Card LED Indications.....	5-4
NIC Motherboards.....	5-5
NIC Media Cards.....	5-6
Requirements and Limitations.....	5-7
Step 1. Configuring Network Cards.....	5-7
Overview.....	5-7
Motherboard Jumper Settings.....	5-7
NIC Card Address Setting.....	5-7
NIC Card Jumper Settings.....	5-8
Wired Media Card Jumper Settings.....	5-8
Step 2. Mounting Media Cards to the NIC.....	5-9
Overview.....	5-9
Media Card Mounting.....	5-9
Step 3. Mounting Network Cards.....	5-10
Step 4. Wiring Network Cards.....	5-11
Overview.....	5-11
Wiring Guidelines.....	5-11
Wiring Distances.....	5-12
Related Documentation.....	5-12
Fiber-Optic Wiring.....	5-13
Fiber Optic Connection Types.....	5-13
4190-9010 Coupler Requirements.....	5-14
Wiring with the Wired Media Card.....	5-15

Wiring Illustrations	5-17
Wired Media, Style 7 Wiring	5-17
Fiber Optic, Style 7 Wiring.....	5-18
Wired Media and Fiber Optic, Style 7 Wiring.....	5-19
Chapter 6 The System Power Supply & Alarm Relay Card.....	6-1
Introduction	6-1
In this Chapter	6-1
SPS Specifications	6-2
Input/Output/Battery Specifications	6-2
SPS Current Consumption	6-3
Environmental Requirements	6-4
SPS Configuration	6-4
Overview.....	6-4
Jumper Settings.....	6-4
Setting the Device Address	6-4
Adjusting Voltages	6-4
SPS LED Indications	6-5
LEDs	6-5
Troubleshooting on SPS.....	6-6
Overview	6-6
IDNet Power Monitor Trouble	6-6
Extra Device	6-6
Class A Trouble	6-6
Earth Fault Search.....	6-6
Short Circuit.....	6-6
Channel Fail.....	6-6
No Answer/ Bad Answer.....	6-6
Output Abnormal.....	6-6
The Alarm Relay Card	6-7
Overview	6-7
Mounting	6-7
Configuration	6-8
Notes.....	6-8
Warning	6-8
Specification	6-8
Chapter 7 SPS Field Wiring (4100U)	7-1
Introduction	7-1
In this Chapter	7-1
General Field Wiring Guidelines.....	7-2
General Guidelines	7-2
SPS NAC Field Wiring Guidelines.....	7-3
Overview.....	7-3
Guidelines.....	7-3
Class A NAC Wiring.....	7-4
Class B NAC Wiring.....	7-5
Power Supply Wiring Distances	7-5
Overview.....	7-5
Class A NAC Wiring Table	7-6
Class B NAC Wiring Table	7-7

SPS Auxiliary Power Wiring	7-8
Overview	7-8
Guidelines	7-8
Wiring	7-9
SPS Relay Wiring	7-10
Overview	7-10
Aux 1 Relay	7-10
Alarm Relay Card	7-10
Relays	7-11
SPS IDNet Wiring	7-12
Overview	7-12
IDNet Wiring	7-12
Guidelines	7-12
Class A Wiring	7-13
Class B Wiring	7-14
Chapter 8 Installing 4100U IDNet & 4100MXP Cards	8-1
Introduction	8-1
In this Chapter	8-1
The IDNet Card	8-2
Overview	8-2
LEDs	8-3
Specifications	8-3
Installing the IDNet Card onto the PDI	8-4
Overview	8-4
Installing the ID-Net into a 4100 Card Bay	8-5
Overview	8-5
Configuring the Card	8-6
Overview	8-6
Setting the Shield Tie Point	8-6
Setting the Address	8-6
Wiring to IDNet Devices	8-7
Overview	8-7
Guidelines	8-7
Notes	8-8
Class A Wiring	8-8
Class B Wiring	8-9
Troubleshooting on IDNet	8-10
Overview	8-10
IDNet Power Monitor Trouble	8-10
Extra Device	8-10
Class A Trouble	8-10
Earth Fault Search	8-10
Short Circuit	8-10
Channel Fail	8-10
No Answer	8-10
Bad Answer	8-10
Output Abnormal	8-10
The 4100MXP	8-11
Introduction	8-11
Power Connection	8-11

Chapter 9 PC Software Connections	9-1
Introduction	9-1
In this Chapter	9-1
Software Modes	9-2
Overview	9-2
Software Modes	9-2
 Chapter 10 Australian Version Specifics.....	 10-1
Introduction	10-1
In this Chapter	10-1
Summary Of Australian Version Specifics.....	10-2
Overview	10-2
AS4428 Requirements.....	10-2
Australian Panel Format	10-3
Overview	10-3
Australian / USA Differences	10-3
4100U/4100A Differences.....	10-3
4100U Fan Control Module	10-4
Overview	10-4
Labeling	10-4
Mounting & Connection	10-4
Programming	10-4
Brigade Interfaces	10-6
Overview	10-6
Format.....	10-6
Applications	10-6
 Chapter 11 Installation Checklist, Commissioning & Maintenance	 11-1
Introduction	11-1
In this Chapter	11-1
Installation Checklist.....	11-2
Overview	11-2
Alignment & Adjustment	11-3
Overview	11-3
Power Up & Placing into Operation	11-4
Maintenance	11-5

Appendix A The Device Configuration DIP Switch.....A-1

Overview.....A-1

Appendix B Programming RequirementsB-1

IntroductionB-1

In this ChapterB-1

Required FeaturesB-1

Notes.....B-1

Appendix C Checking System Wiring.....C-1

Overview..... C-1

Using the Volt/ Ohm Meter C-1

Meter Readings C-2

Appendix D Earth Fault Detection.....D-1

Overview..... D-1

General Guidelines..... D-2

Earth Fault Searching from the Front Panel..... D-3

Overview..... D-3

Access Level Selection..... D-3

Starting the Earth Fault Search D-3

Search Option A: Select Location..... D-4

Search Option B: Select Channel..... D-5

Search Option C: Last Search Result..... D-5

Completing the Search D-5

Search Results D-6

Overview..... D-6

Non-Point Faults D-6

Point Faults..... D-6

Fault Not Found..... D-7

No Fault D-7

Result Not Available D-7

Earth Fault Search Example..... D-8

Appendix E Related Documentation.....E-1

Appendix F Compatible Actuating Devices F-1

IntroductionF-1

In this ChapterF-1

List of Approved Devices.....F-1

Compatible Detectors, IDNETF-4

Compatible Addressable Field Devices, IDNetF-5

Appendix G Compatible Batteries.....	G-1
Appendix H 4100U Specifications.....	H-1
General	H-1
Fuses	H-1
Firmware Features.....	H-1
Voltage & Current Ratings of Modules & Assemblies	H-2
Appendix I Power Supply & Battery Capacity Calculations ...	I-1
Power Supply.....	I-1
Battery Capacity	I-1
Appendix J Cable Characteristics.....	J-1
IDNet.....	J-1
4100 MAPNET II.....	J-1
NETWORK	J-1
Appendix K List of Drawings.....	K-1

List of Figures

Figure 1-1.	Standalone 4100U System	3
Figure 1-2.	MINIPLEX 4100U System	5
Figure 1-3.	Hub/Ring Configuration	6
Figure 1-4.	Interconnected Loop Configuration.....	7
Figure 2-1.	Master (CPU) Motherboard (566-227).....	2-3
Figure 2-2.	Master Controller Daughter Card (566-149).....	2-4
Figure 2-3.	Operator Interface.....	2-6
Figure 2-4.	System Power Supply.....	2-7
Figure 2-5.	The Power Distribution Interface (PDI).....	2-8
Figure 2-6.	Bracket Mounting.....	2-9
Figure 2-7.	Bay-to-Bay Interconnections.....	2-13
Figure 2-8.	Power and Communication Wiring for Motherboards.....	2-14
Figure 2-9.	Expansion Bay 4"x 5" Card Placement.....	2-15
Figure 2-10.	Expansion Bay Motherboard Placement	2-16
Figure 2-11.	Mixed Module Placement	2-17
Figure 2-12.	Slave Card/PDI Connection.....	2-18
Figure 2-13.	Installing the Motherboard in a 4100U Expansion Bay.....	2-19
Figure 2-14.	LED/Switch Modules.....	2-21
Figure 2-15.	LED/Switch Controller.....	2-21
Figure 2-16.	LED/Switch Card Mounting.....	2-23
Figure 2-17.	Controller Card Mounting.....	2-24
Figure 2-18.	Assembling / Disassembling the LED Display Card	2-25
Figure 2-19.	LED/Switch Controller Wiring	2-26
Figure 2-20.	Terminal Block Utility Module Mounting	2-27
Figure 3-1.	MINIPLEX System Design.....	3-31
Figure 3-2.	The Remote Unit Interface Card.....	3-32
Figure 3-3.	The RIC II Card.....	3-33
Figure 3-4.	Installing the RUI Motherboard in the CPU Bay	3-35
Figure 3-5.	Installing the RIC II Motherboard into a 4100 Expansion Bay	3-36
Figure 3-6.	Power and Communication Wiring for the Transponder Cabinet (4100).....	3-38
Figure 3-7.	MINIPLEX Wiring.....	3-40
Figure 4-1.	Transponder Interface Cards.....	4-4
Figure 4-2.	TIC Mounting	4-9
Figure 4-3.	Transponder Cabinet Interconnections.....	4-10
Figure 4-5.	TIC Wiring to the Host Panel	4-11
Figure 5-1.	4100-6014 Network Interface Card.....	5-4
Figure 5-2.	UT Motherboard with City Connection (565-274).....	5-5
Figure 5-3.	UT Motherboard without City Connection (565-275).....	5-5
Figure 5-4.	The 4100/4120-0143 Fiber-Optic Media Card.....	5-6
Figure 5-5.	The 4100/4120-0142 Wired Media Card	5-6
Figure 5-6.	Media Card Mounting	5-9
Figure 5-7.	Installing the Daughter Card	5-10
Figure 5-8.	The Transient Suppressor	5-12
Figure 5-9.	Fiber Wiring.....	5-13
Figure 5-10.	Coupler Wiring	5-15
Figure 5-11.	Wired Media Interconnections Between 4100U Motherboards.....	5-16
Figure 5-12.	Wired Media, Style 7 Wiring	5-17
Figure 5-13.	Fiber Optic, Style 7 Wiring	5-18
Figure 5-14.	Wired Media and Fiber Optic, Style 7 Wiring.....	5-19
Figure 6-1.	The Alarm Relay Card	6-7
Figure 7-1.	The Ferrite Bead (SX0005).....	7-2
Figure 7-2.	Class A NAC Wiring.....	7-4
Figure 7-3.	Class B Wiring	7-5
Figure 7-4.	Auxiliary Power Wiring.....	7-9
Figure 7-5.	Auxiliary Relay & Alarm Relay Card Relays	7-11
Figure 7-6.	Class A Wiring	7-13
Figure 7-7.	Class B Wiring	7-14
Figure 8-1.	The IDNet Card.....	8-2

Figure 8-2.	Mounting onto the Power Distribution Interface.....	8-4
Figure 8-3.	Mounting into 4100 (legacy) Bay	8-5
Figure 8-4.	DIP Switch SW1.....	8-6
Figure 8-5.	Class A Wiring	8-8
Figure 8-6.	Class B Wiring	8-9
Figure 9-1.	Service and Diagnostic Interface	9-2
Figure 9-2.	Data Transfer Interface	9-2
Figure 9-3.	Bootloader Interface	9-3
Figure 10-1.	Fan Control Module	10-5
Figure D-1.	Volt/Ohm Meter Readings	D-1
Figure G-1.	Earth Fault Search Example.....	G-8

List of Tables

Table 2-1	Master Controller LEDs 1 through 4.....	2-1
Table 5-1	4100 NIC & Media Cards – Electrical and Environmental Specifications.....	5-7
Table 5-2	Wiring Distances.....	5-12
Table 5-3	Dual Fiber Optic Cable Communications Distance Examples ...	5-14
Table 5-4	Single Fiber Optic Cable Communications Distance Examples using 4190-9010 Bi-Directional Couplers.....	5-14
Table 5-5	566-227 CPU Motherboard Wired Media Connections	5-16
Table 6-1	SPS Input and Output Specifications	6-2
Table 6-2	SPS Current Specifications	6-3
Table 6-3	Alarm Relay Card Jumper Positions.....	6-8
Table 7-1	Class A Wiring Distances	7-6
Table 7-2	Class B Wiring Distances	7-7
Table 8-1	IDNet Specifications	8-3
Table 8-2	Cable Run Lengths	8-8
Table 10-1	Switch/LED Format.....	10-4
Table 10-2	Switch Status	10-4
Table A-1	Card Addresses	A-2
Table C-1	Acceptable Zone and Signal Circuit Meter Readings.....	C-2

Chapter 1

Introduction to the 4100U Fire Alarm System

Introduction

The 4100/4100U is an expandable fire alarm system that can be used as a standalone system with one host panel, or as a wide-ranging system with several remote cabinets, with or without multiple host panels. This chapter is an overview of standalone, MINIPLEX, and network 4100 system concepts.

In this Chapter

Refer to the page number listed in this table for information on a specific topic.

Topic	See Page #
System Configurations	1-2
Standalone Configuration	1-3
MINIPLEX Configuration	1-4
Network Configuration	1-6
4100 PIDs (Non-4100U)	1-8
4100U Cabinet Part Identification Numbers (PIDs)	1-9
4100U PIDs	1-9

System Configurations

Overview

The 4100U is available as a standalone system with one host panel, or as an expansive system with several remote back boxes, with or without multiple host panels. The type of configuration used depends on the size of the site into which it is being installed.

The following types of configurations are offered:

Standalone. Comprised of one FACP and its assorted warning devices, initiating devices, and signaling line circuit devices.

MINIPLEX. A standalone system plus remote transponder cabinets, which allow for additional slave modules to be used. Typically used for multi-level buildings and small multi-building applications.

Network. A multi-FACP system connected by network cards. Each panel maintains the status and control of its own circuit points while monitoring and controlling activity at other locations. Network nodes may perform similar tasks, or may be dedicated to specific functions.

This chapter outlines the fundamental concepts of each configuration.

Standalone Configuration

Overview

The standalone version of the 4100U is used for smaller or single-building applications. A standalone system is ideally placed into a small building that requires a limited number of notification appliances and initiating devices.

If a small building is being expanded, or if other buildings are being constructed in the same general area (as in a campus application), the standalone 4100U can be expanded into one of the larger systems described later.

System Design

The standalone 4100U uses one FACP (one, two, or three bays) containing the following:

- CPU
- System Power Supply for the 4100U (Universal Power Supply for the 4100)
- Optional slave cards

All appliances and devices are connected to that one FACP, as shown in Figure 1-1.

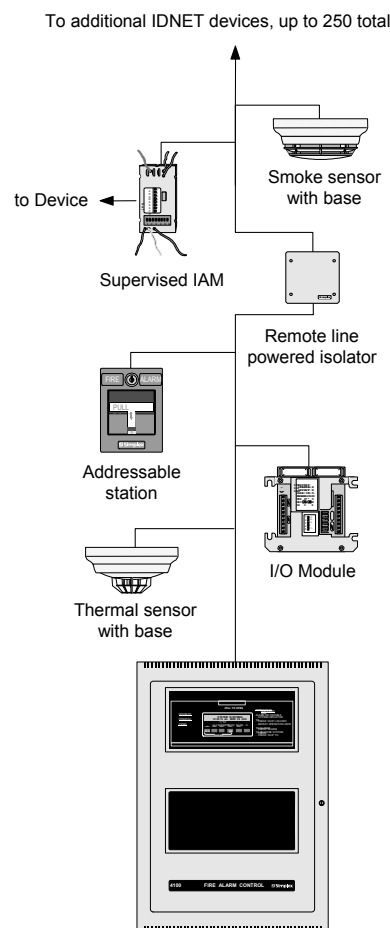

Figure 1-1. Standalone 4100U System

MINIPLEX Configuration

Overview

The MINIPLEX version of the 4100 Fire Alarm System, which is designed for moderately larger applications than the standalone configuration, allows up to 1000 monitor and/or control points and 2000 annunciator points to be controlled by a single FACP.

Like the standalone system, only one CPU is used. Remote Unit Interface (RUI) data, and optionally power is distributed from the host panel to remote boxes called *transponder cabinets*. The exact system design varies, depending on whether the system is a 4100 or a 4100U:

- **4100U:** *Transponder interface cards (TICs)*, located in transponder cabinets, take the RUI data directly from the CPU motherboard and distribute it to modules nearby, thereby expanding the system's status from standalone to MINIPLEX.
- **4100:** *Remote interface cards (RICs)*, located in transponder cabinets, take the RUI data and optionally power from the *remote unit interface (RUI) card* in the host panel and distribute it to modules nearby, thereby expanding the system's status from standalone to MINIPLEX.

System Design

The MINIPLEX 4100 FACP must contain the following:

- CPU
- System Power Supply for the 4100U (Universal Power Supply for the 4100)
- **4100 only (non-4100U):** Remote unit interface (RUI) Card
- Optional slave cards

Each transponder cabinet, meanwhile, must contain a Transponder Interface Card (TIC) and any number of optional slave cards.

Continued on next page

MINIPLEX Configuration, *Continued*

RUI Communication

The 4100 internal comms bus may be used to carry data from the CPU in the main cabinet to expansion equipment in a co-located cabinet. 4100 data from the CPU may be routed to remote cabinets (RTUs) in a MINIPLEX system by using the external RUI comms bus. An RUI line, routed from either the CPU Motherboard in the 4100U, or the RUI card in the 4100, allows the data to travel long distances. Once the RUI line terminates at a remote cabinet, the TIC (4100U) or RIC (4100) in that cabinet distributes the CPU's data to the other modules within the cabinet.

Power has to be supplied locally within each RTU, or routed from the main FIP. Figure 1-2, below, outlines this process in a typical MINIPLEX setup.

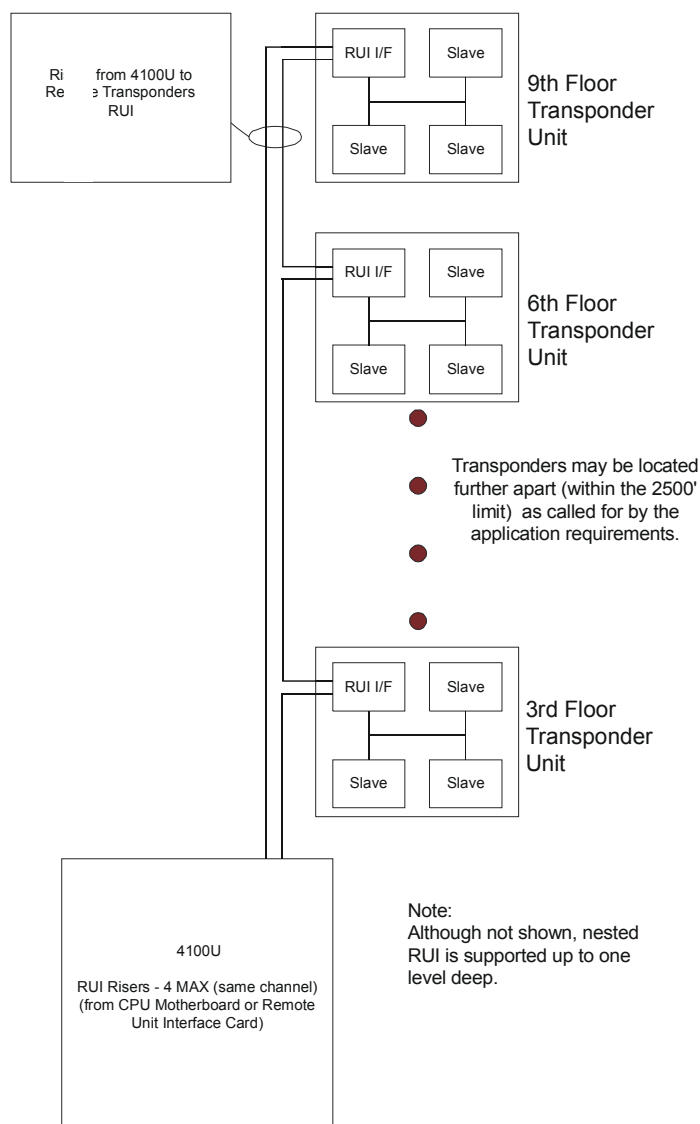

Figure 1-2. MINIPLEX 4100U System

Network Configuration

Overview

The 4100 can be expanded to a network system by using network interface cards (NICs). When a NIC is installed into a 4100 host panel, it is used to connect to other network nodes. Nodes may consist of other host 4100 panels, or they may be completely different: Graphical Command Centers (GCCs), and Visual Command Centers (VCCs) are all examples of what could be used as nodes. A node is a self-sufficient CPU that controls appliances and devices, which also has the capability of controlling and communicating with other nodes.

The network configuration supports two prevalent architectures (or wiring configurations): **hub** (or *ring*), or **star**. A networked system can also use a combination of the two.

Hub and Star Configurations

The hub configuration consists of a main loop with nodes connected in a radial manner. The star configuration consists of several nodes connected directly to one common node. Physical bridge cards are used for the star configuration. Physical bridges reduce the amount of wire that would otherwise be needed to connect all nodes in a loop, and therefore cut down on system response time. A combination of the two styles is illustrated in Figure 1-3.

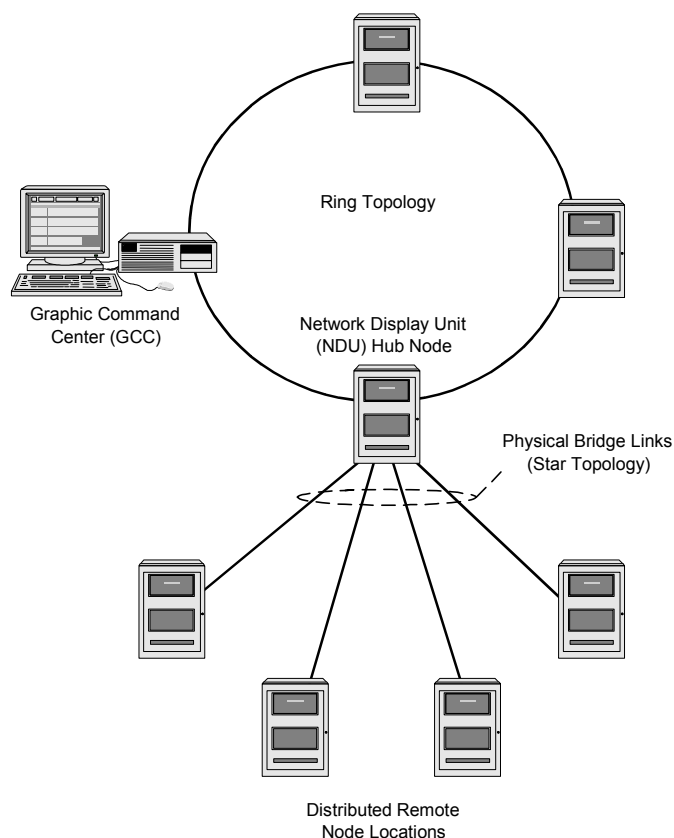

Figure 1-3. Hub/Ring Configuration

Continued on next page

Network Configuration, *Continued*

Connecting Loops

Network loops can be joined via physical bridge cards. There may be no more than two Style 7 network loops (two hub configurations) connected in tandem. For every two loops that are interconnected (using one physical bridge), there can be a maximum of three physical bridges used in a star configuration. See Figure 1-4.

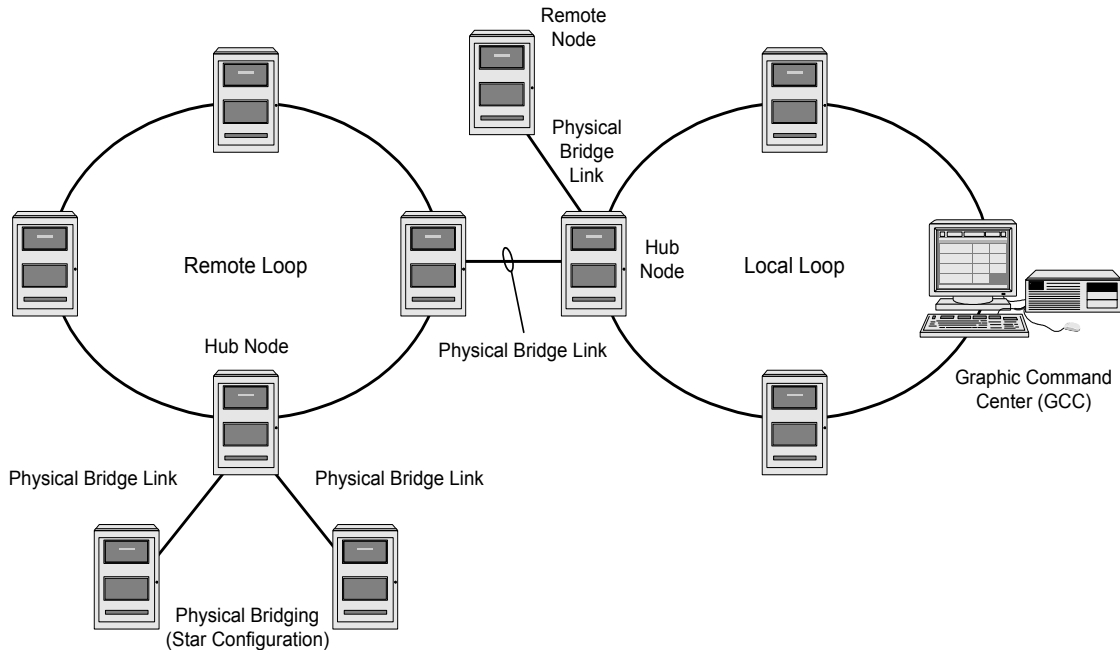

Figure 1-4. Interconnected Loop Configuration

System Design

To be used as a network node, a 4100 panel must contain the following:

- CPU
- System Power Supply
- 4100 Network Interface Card
- Optional slave cards

Network Communication

Network communication is achieved via 4100-6014 or 4100-6035 Network Interface Cards (NICs). Each network node requires a NIC. Once the FACP is a network node, it may be programmed to be fully in control of other nodes, or to be fully passive, or anywhere in between.

4100 PIDs (Non-4100U)

The following is a list of existing 4100+/A cards and modules that may be used with 4100U.

- 4100-5004 8 AZF Monitor Zone
- 4100-0113 Dual RS232 Modem Interface
- 4100-0110 MAPNET 2 Addressable Loop
- 4100-3003 8 Relay Module
- 4100-4321 6 Supervised Relays
- 4100-3024 24 Relay Module
- 4100-0302 24 I/O Module
- 4100-0111 Quad Isolator Module
- 4100-0149 Modular Network Card (required 2 media cards)
- 4100-0142 Wired Media Card RS485
- 4100-0143 Fibre Optic Media Card
- 4100-0301 LED Switch Controller
- 4100-0154 VESDA High Level Interface
- 4100-0157A 4100A PSU
- 4100-0451 Printer

Annunciation Modules

- 4100-0301 64/64 LED/Switch Controller
 - 4100-0302 24-Point I/O Graphic Interface
 - 4100-0401 8-LED Display Card (Red LEDs)
 - 4100-0402 16-Point Display Card (Red/Yellow LEDs)
 - 4100-0403 8-Switch/8-LED Display Card (Momentary switches; red LEDs)
 - 4100-0404 8-Switch/16-LED Display Card (Maintained switches; one red and one green LED per switch)
 - 4100-0405 8-Switch/16-LED Display Card (Maintained switches; one red and one yellow LED per switch)
 - 4100-0408 8-Switch/8-LED Annunciator Control Switch Module
 - 4100-0450 Remote Panel LCD
-

4100U Cabinet Part Identification Numbers (PIDs)

Overview

This section lists all cabinet (back box) PIDs for the 4100U Fire Alarm System.

4100U Cabinets

Empty cabinets with Doors (Cream Wrinkle)/ Number of bays that can be fitted:	Number of bays
• ME0447 18U x 210 Rack Cabinet, Window Door	: 1-Bay
• ME0268 21U x 310 Rack Cabinet, Window Door	: 1-Bay
• ME0255 28U x 310 Rack Cabinet, Window Door	: 2-Bays
• ME0257 40U x 310 Rack Cabinet, Window Door	: 3-Bays
• ME0454 18U x 210 Rack Cabinet, Solid Door	: 1-Bay
• ME0269 21U x 310 Rack Cabinet, Solid Door	: 1-Bay
• ME0265 28U x 310 Rack Cabinet, Solid Door	: 2-Bays
• ME0267 40U x 310 Rack Cabinet, Solid Door	: 3-Bays

4100U PIDs

Overview

This section lists the PIDs that are supported by the 4100U Fire Alarm System.

Assemblies, Cards & Modules

The following is a list of assemblies, cards and modules used in 4100U:

- 566-084 Power Distribution Interface (ie the back-plane)
 - 742-516 CPU Motherboard (566-227)
 - 4100-7151 Master Controller (CPU Card 566-149)
 - 4100-2300 Expansion Bay Assembly (includes the metalwork with the PDI back-plane)
 - 4100-6033 Alarm Relay Card (566-058. Small card plugged onto the SPS and used to supply the Brigade I/F relays).
 - 4100-3101 IDNET Module – 250 pt capacity (566-044)
 - 4100-1288 64 LED/64 Switch Controller module w/mounting plate
 - 4100-1289 64 LED/64 Switch Controller module
 - 4100-1282 8 SW/16 LED red/yellow module
 - 4100-1287 24 Switch/24 red LED module
 - 4100-1284 8 Switch 16 red/green LED module
 - 4100-1281 8 Switch 8 yellow LED module
-

Continued on next page

4100U PIDs, *Continued*

-
- 4100-0625 Transponder Interface Card
 - 4100-0160 Internet Interface Module (566-355).
 - 4100-9848AU System Power Supply, Australian version.
 - ME0456 Fan Control Module
-

Kits

The following kits are available:

- KT0419 A4 Document Holder, Stick-On, 3U High, Grey
- KT0446 4100U Expansion Bay
- KT0447 Expansion SPS, Bay Mounting
- KT0448 Fused DC Distribution Bd, XSPS AU Mounting
- KT0450 4100-4100U Upgrade, 19" RAC Mounting
- KT0452 IDNet Mounted on 4100 Interface Bracket
- KT0468 4100 MBd to 4100U Bay, Mounting Kit
- KT0469 A5 Document Holder, Stick-On, 3U High, Grey

Brigade Interfaces

- KT0199 19", 3U ASE Mounting Bracket, plus
KT0207 ASE FAS Interface Loom
 - FZ9028 19", 3U AIU/PPU Mounting Bracket & Loom
-

Labels

LB0602 Operator I/F ISO/Test, Card
LB0605 Fan Control Zone Insert Card
526-873 Slide In Label, LED Switch Module, 1 Sheet of 6
4100-1294 Module Slide In Labels, Panel Set

Looms

LM0309 4100U Mains Lead With Filter
LM0310 4100U Battery Lead Set, 18U-21U (1976-132-1)
LM0311 4100U Battery Lead Set, 28U-40U (1976-132-2)
734-008 Harness, Power Comms, 4 Way, 2ft Length
734-075 Harness, Power Comms, 4 Way, 8ft Length
SX0039 Sw/LED Module Ribbon Cable, 26 Way, 2in
SX0052 Sw/LED Module Ribbon Cable, 26 Way, 6in

Chapter 2

Installing 4100U FACP Components

Introduction

4100U cabinets are available in one-, two-, and three-bay sizes. Each can be equipped with a solid or perspex door. This chapter describes how to mount all types of 4100U cabinets to a wall, and how to mount system card bays into the cabinets, modules to bays, etc.

FACPs are assembled to order within the factory. Steps 2 to 6 below are therefore not typically required in the field, but are included in case of in-field system expansion.

The section Introduction to FACPs describes the various components that make up the FACP.

The assembly drawings 1976-136, 1976-137 are included in the appendix of this manual for reference.

In this Chapter

Refer to the page number listed in this table for information on a specific topic.

Topic	See Page #
Introduction to FACPs (4100U)	2-2
Step 1. Mounting Cabinets (4100U)	2-9
Step 2. Mounting Card Bays to Cabinets (4100U)	2-9
Step 3. Configuring Cards (4100U)	2-10
Step 4. Interconnecting Modules and Bays	2-11
Step 5. Installing Modules into Expansion Bays (4100U)	2-15
Step 6. Installing LED/Switch Modules into Expansion Bays (4100U)	2-20
The Terminal Block Utility Module (4100U)	2-27

Introduction to FACP's (4100U)

Overview

4100U FACP's cabinets contain the CPU, operator interface, system power supply (SPS), backup batteries, and any additional modules that the panel requires. The FACP is the central hub (often referred to as a host panel) of a standalone or MINIPLEX fire alarm system. In a networked system, the FACP can be connected to other system FACP's, so that each host panel is a node on the network.

CPU Bay

In the standard (USA) version of 4100U the CPU bay contains an SPS, the Master Motherboard with CPU Daughter card, but no PDI to which 4" x 5" cards (e.g. IDNet card) can be fitted. Also, it has the Operator Interface (I/F) on its front, so no switch/LED display modules can be fitted to it.

In the Australian version the SPS is fitted to a bracket behind a side-hinged 4U door that has the Operator I/F on it. The Master Motherboard (i.e. CPU Motherboard) is fitted to the right hand side of an expansion bay mounted directly below. This bay has a PDI fitted so can house 4" x 5" cards and Switch/LED Display Modules.

Continued on next page

Introduction to FACPs (4100U), *Continued*

Master Motherboard

The 4100U Master motherboard that houses the CPU card is central to the 4100U system. It mounts in the first bay, occupying four inches of space on the right hand side. Neither has a card address DIP switch (the CPU is address 0).

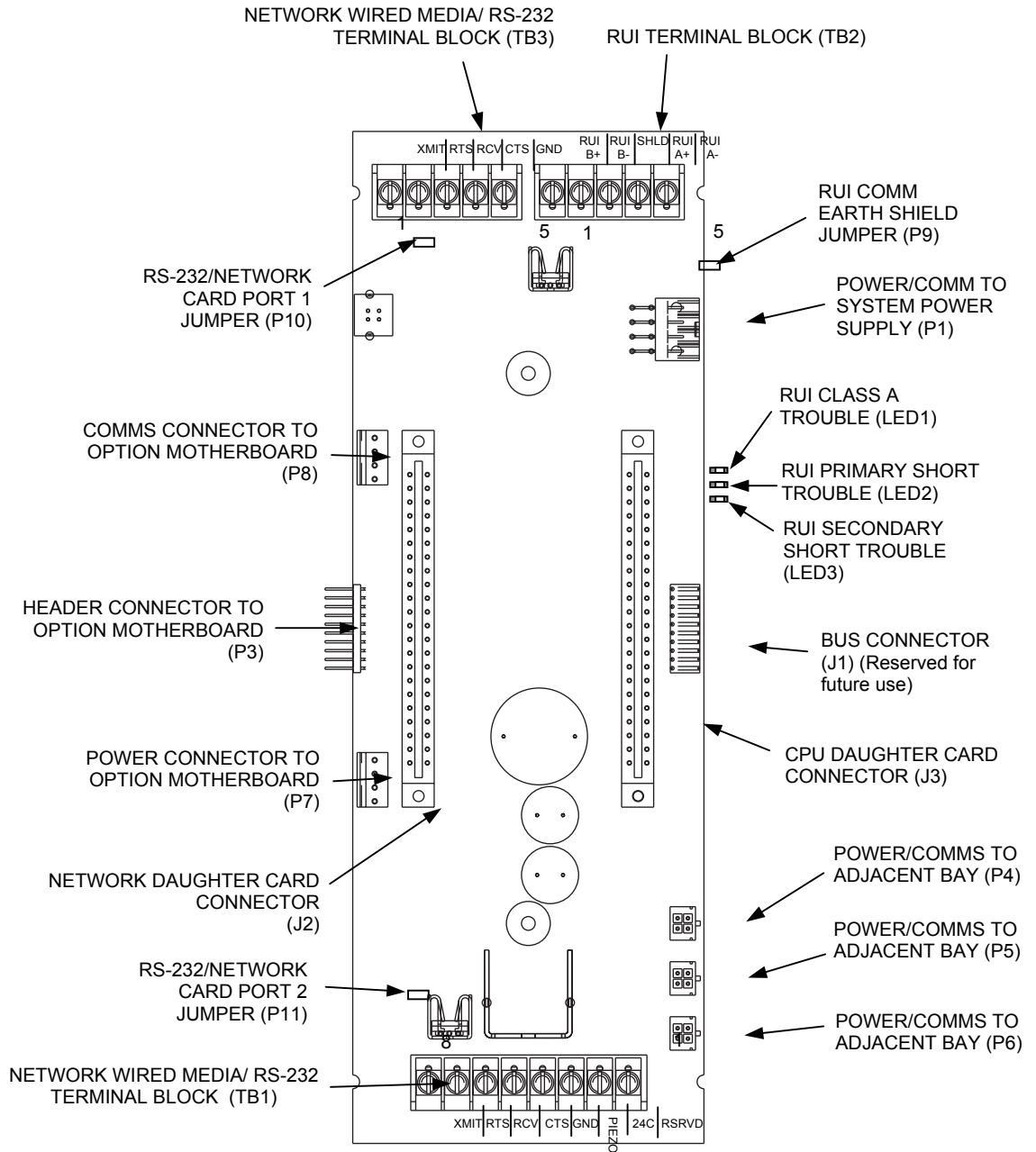

Figure 2-1. Master (CPU) Motherboard (566-227)

Continued on next page

Introduction to FACP (4100U), *Continued*

Master Controller Daughter Card

The master controller daughter card mounts onto the master motherboard. The master controller daughter card contains a service port, a direct drive user interface connection, and a port for a service modem.

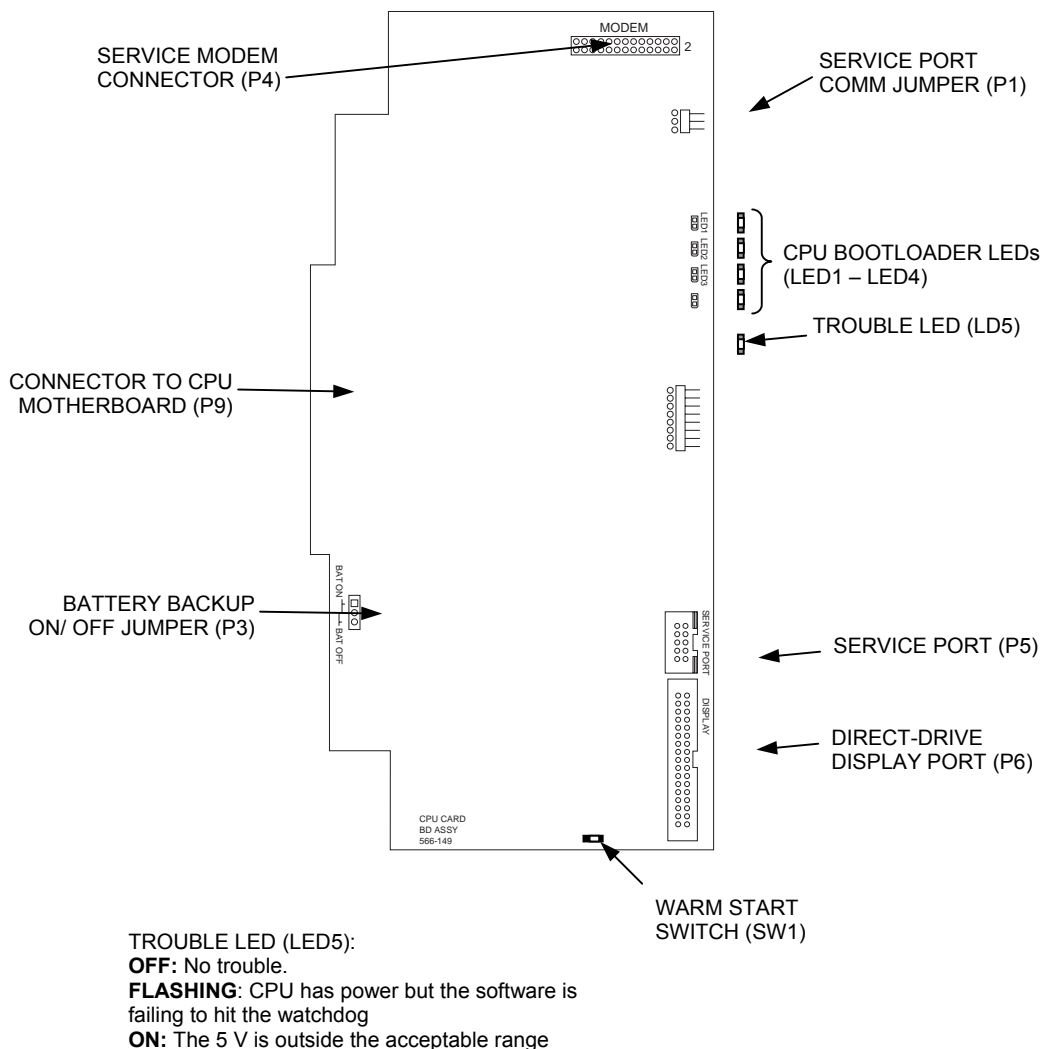

Figure 2-2. Master Controller Daughter Card (566-149)

Continued on next page

Introduction to FACPs (4100U), *Continued*

Master Controller Daughter Card LEDs

The master controller daughter card LEDs indicate Bootloader status as shown in the table below.

Table 2-1. Master Controller LEDs 1 through 4

Status Condition	LED4	LED3	LED2	LED1
Bootloader Initialization	On (0.25s), Off (0.25s)	On (0.25s), Off (0.25s)	On (0.25s), Off (0.25s)	On (0.25s), Off (0.25s)
Bad Master CRC or No Master Present	On	Off	Off	Off
Diagnostic Fail – RAM	On	Off	Off	On
Diagnostic Fail – Bootloader CRC	On	Off	On	Off
Downloading Master	On	Off	On	On
Downloading CFG	On	On	Off	Off
Downloading MsgLib	On	On	Off	On
Downloading BootLoader	On	On	On	Off
Download Successful	On	On	On	On

Continued on next page

Introduction to FACPs (4100U), *Continued*

Operator Interface

The operator interface lets a user operate the panel. It provides alarm, trouble, and isolate status alerts, and lets the user review historical logs and perform diagnostics.

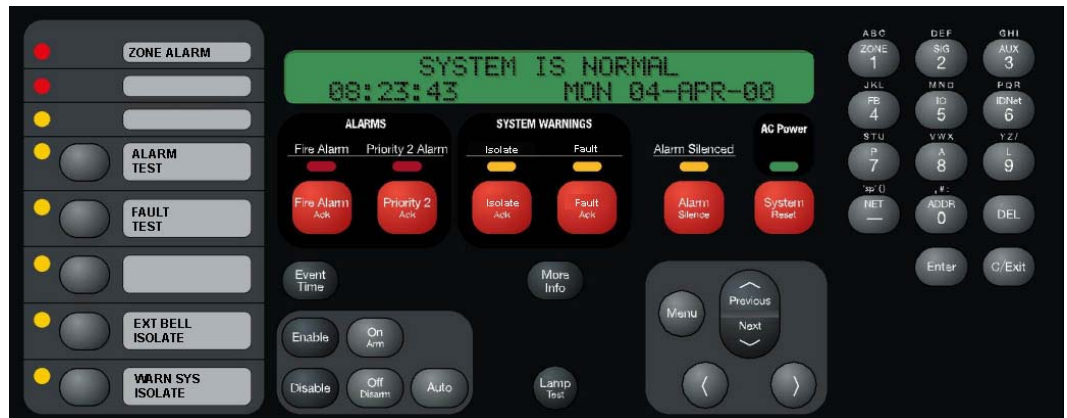

Figure 2-3. Operator Interface

Additional CPU Bay Modules

The CPU bay can be equipped with many additional types of modules. The cards listed below are limited to the CPU bay only.

4100-6030 Service Modem Card. CPU mezzanine card. Provides a connection to remote PCs for diagnostics and programming purposes. (Not approved for use in Australia).

4100-6014 Modular Network Interface Card (NIC). A daughter card that mounts to the CPU motherboard. Performs 4100 networking operations. May be installed with the 4100-6056 Wired Media Card and/or the 4100-6057 Fiber Media Card.

Expansion Bays

An FACP always has the CPU in the first bay, but it may have further expansion bays. Expansion bays contain a variety of additional modules that the system might require.

Continued on next page

Introduction to FACPs (4100U), *Continued*

System Power Supply (SPS)

In the USA, a number of variants of power supply are available, e.g. SPS, RPS, XPS, XCharger each with different portions of circuitry (eg NACs, Battery Charger, IDNet) fitted or not fitted. In Australia, only one variant (SPS) is currently available, and it has hardware and software that are specific to Australia. This unit is used as the main power supply, but may also be fitted directly to a card bay as an expansion supply.

The system power supply (SPS) is mains powered and has backup batteries that get switched in on mains failure. It is the initial power source for the CPU and the host cabinet. The SPS provides 24V card power to the CPU motherboard and the other cards. It also supplies 24V power on a separate bus to the outputs, e.g. Notification Appliance Circuits (NACs).

The SPS also has three on-board NACs that support reverse polarity supervision. It provides an IDNet channel, auxiliary power, an auxiliary relay, and it mounts and drives the Alarm Relay Card.

The SPS performs functions such as brownout detect, battery transfer, battery recharge, earth fault detection, and power limiting of outputs. It provides voltage and current information to the CPU card, which can then be displayed at the user interface.

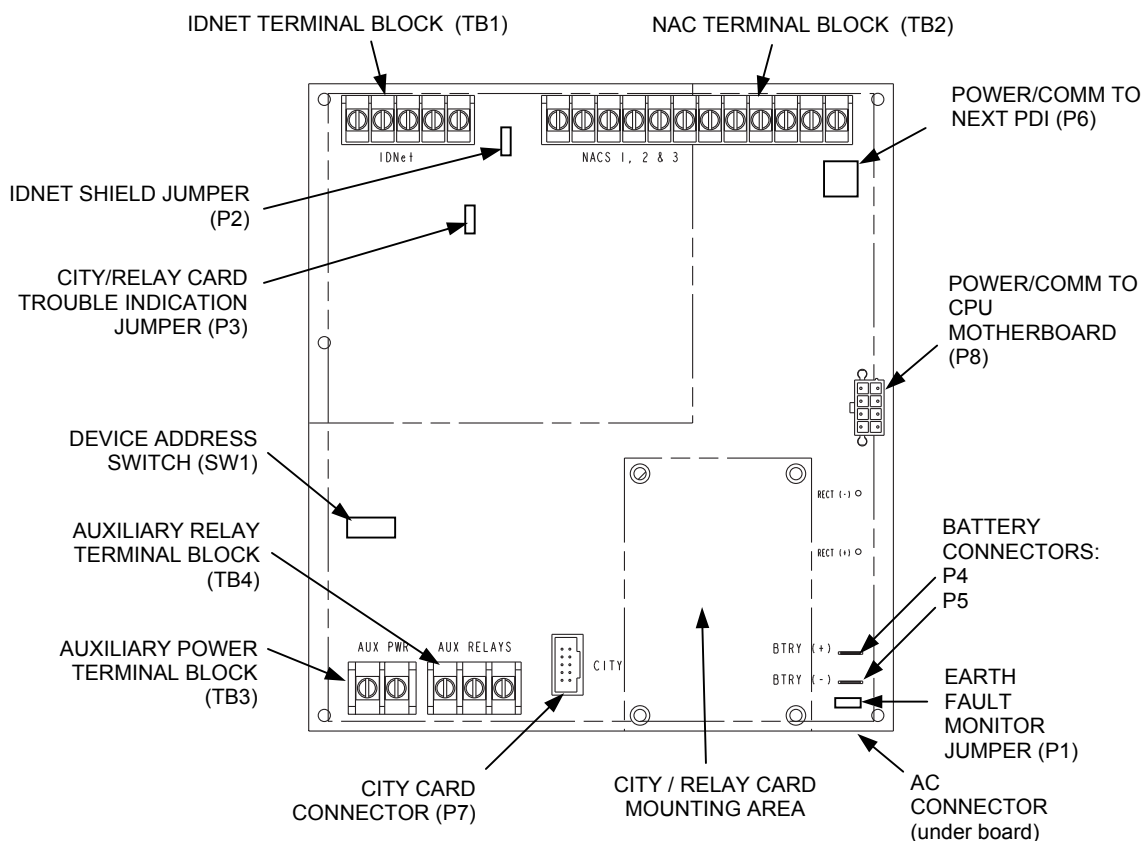

Figure 2-4. System Power Supply

Continued on next page

Introduction to FACPs (4100U), *Continued*

System Power

The FACP is powered by the SPS (System Power Supply), which gets its primary power from the AC mains and its secondary power from the backup batteries.

The 24Vdc bulk power on the SPS is unregulated, and is divided into three feeds, i.e. 24V Card, 24V Signal, and 24V Aux Power. 24V Card which supplies the cards, and Aux power, which is accessible on screw terminals, are each rated at 2A and protected by a PTC. The 27.3V regulated battery charger is powered from the bulk supply and is switched off during alarm. The batteries only get connected to the bulk supply when the mains supply fails. The charger has two programmable options of rating, 1.4A for 6-18Ahr (called little-uns), and 3.3A for batteries above 18Ahr (called big-uns).

The “heavy” 24V Signal feed is only accessible via the NACs on the SPS, or via a wire harness.

IMPORTANT: AC power must be provided to the 4100U from a dedicated branch circuit.

The Power Distribution Interface (PDI)

In expansion bays, power and data are distributed via the power distribution interface (PDI). The PDI is a wiring board with eight card slots, each of which can accommodate a 4-inch (102 mm) x 5-inch (127 mm) slave card. If motherboards are used, they must be mounted over the PDI using metal standoff.

Standards cards, e.g. IDNet, plugged onto the PDI access only the 24V Card supply.

If an XSPS is plugged onto the PDI, then the 24V Signal Bus is also powered. This is required for the 4100MXP which uses card power to power its electronics, but signal power to supply the 40V loop.

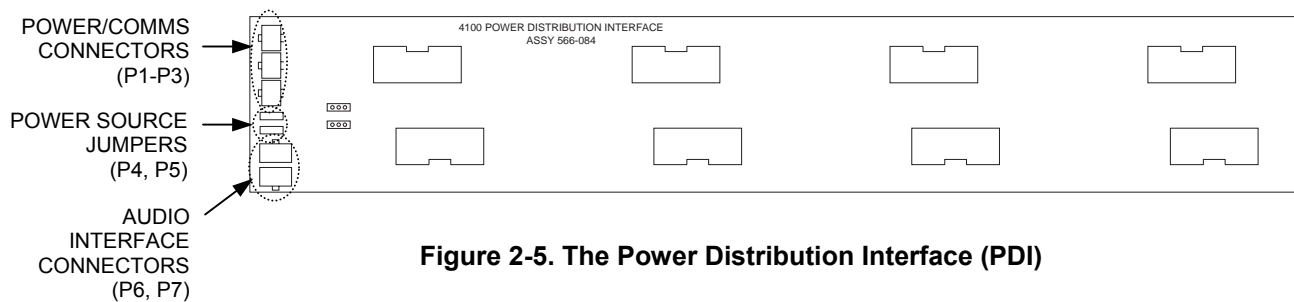

Figure 2-5. The Power Distribution Interface (PDI)

Step 1. Mounting Cabinets (4100U)

Overview

The important aspects of mounting the cabinet are:

Access for the operator;
Height of displays and controls;
Free space for door opening;
Cable entry for field wiring.

Refer to AS1670 for the height requirement and minimum access requirements.

In general, 18U – 28U cabinets will need to be wall mounted. Mounting holes and cabinet dimensions are shown in drawing 1919-22b.

Door opening left/right should be specified with the order. The cabinets are symmetrical, top to bottom, so door opening can be swapped by removing the equipment, rotating the cabinet 180°, then re-fitting the equipment.

Step 2. Mounting Card Bays to Cabinets (4100U)

Overview

FACPs are ordered from the factory with bays and cards fitted as per the panel order spreadsheet.

Additional mounting bays may be ordered as KT0447 which includes the 19" rack mounting brackets and earth loom.

Attach each mounting bracket to the two studs in each front corner to achieve the format shown below. Fit M6 cage nuts to the appropriate 19" rack holes, then attach the bay using M6 countersunk screws.

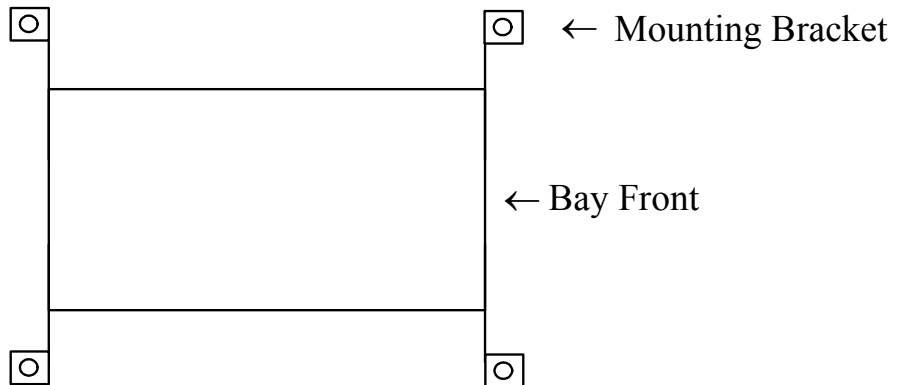

Figure 2-6. Bracket Mounting

Refer to the assembly drawings in the Appendix.

Step 3. Configuring Cards (4100U)

Overview

The CPU, SPS, and all other modules to be mounted in the FACP cabinets must be configured to operate correctly in the system via their DIP switch and jumper ports. This section describes the hardware configuration for the CPU and SPS, since they will always be used in the CPU bay.

Master Motherboard Configuration

The CPU motherboard must be jumpered as follows:

P9 determines whether the RUI SHIELD signal is connected to 24 C or Earth.

- Position 1 – 2: SHIELD to 24 C (default). Set to this position **unless** the system uses a TrueAlert Power Supply.
- Position 2 – 3: SHIELD to Earth. Set to this position **only if** the system uses a TrueAlert Power Supply.

Note: Some devices that connect to RUI have inherently grounded shield terminals, in which case 24 C cannot be used. If 24 C is used, a Negative Ground Fault will occur.

P10/P11: P10 is associated with Port 1 and P11 is associated with Port 2. P10 and P11 are used to set the CPU motherboard up to be attached to either a network card or a RS-232/2120 card.

- Position 1 – 2: Network card (NIC) attached to CPU motherboard (default).
 - Position 2 – 3: RS-232/2120 card attached to CPU motherboard.
-

Master Controller Daughter Card Configuration

The master controller daughter card must be jumpered as follows:

P1 is used for engineering diagnostics (COMLAB).

- Position 1 – 2 : Download or no connection.
- Position 2 – 3 : Diagnostic mode.

P3 configures the RAM battery as ON or OFF.

- Position 1 – 2 : ON.
 - Position 2 – 3 : OFF.
-

SPS Configuration

The SPS must be configured as follows:

SW1: Using DIP switch SW1, set the SPS device address. Use the address table in Appendix A.

P2: If the SPS IDNet outputs are being used, you may change P2 to configure the IDNet shield connection.

- Position 1 – 2 (bottom) : Connects the shield to 0 V (default).
- Position 2 – 3 (top) : Connects the shield to earth ground.

P3 configures relay 3 on the 4100-6033 Alarm Relay Card.

- Position 1 – 2 (top) : Removes fault monitoring on relay 3 (default).
- Position 2 – 3 (bottom) : Makes relay 3 activate when there is a fault.

P1: Earth connect jumper.

- Position 1 – 2 (rhs): Enables Earth fault monitoring. Set to this position **unless** the system uses a TrueAlert Power Supply under common 0 V.
 - Position 2 – 3 (lhs): Disables Earth fault monitoring. Set to this position **only if** the system uses a TrueAlert Power Supply under common 0 V.
-

Continued on next page

Step 3. Configuring Cards (4100U), *Continued*

PDI Configuration

P4/P5: The PDI can be configured to draw its power from different sources via P4 and P5.

- To draw power from an XPS on the PDI, set jumpers on P4 and P5 to position 2 – 3.
- To draw power from P1 (from the previous PDI or SPS), set jumpers on P4 and P5 to position 1 – 2 (default).
- To remove power from the PDI, remove the jumper from P4.

Configuring Other Cards

Refer to the appropriate installation instructions to configure other cards that are located in CPU and expansion bays. The 4100U ones are included in this manual. Refer to Appendix D for a list of publications.

Step 4. Interconnecting Modules and Bays

Overview

Each card has to be interconnected with every other card in its bay. At the same time, bays in the FACP also have to be connected together. Read this section to ensure that cards and bays are interconnected. Refer also to drawings 1976-136 and 1976-137.

Guidelines

Review the following guidelines before interconnecting modules and bays.

- The SPS provides 24 V power to the CPU motherboard.
 - The CPU motherboard provides 8 V (3 A capacity) for use by Legacy 4100 slave cards. 24 V card power is routed through the motherboard for slave card use.
 - 4100 internal comms and power are harnessed to other bays. Do not connect the 8 V at P7 to an 8 V converter on a Goldwing or remote interface card.
 - 24 V Card power from the SPS is rated at 2 A.
 - The 4-wire coms and power harness carries only the 24 V Card supply to a PDI, and not the 24V Signal supply.
 - Some of the wire harnesses supplied with cards are not required. It is recommended to store these spare harnesses in case of future requirements.
-

Continued on next page

Step 4. Interconnecting Modules and Bays, *Continued*

Card Interconnections in the CPU Bay

Use the following directions to connect the CPU to the SPS and other motherboards.

1. Connect P3 on the SPS to P1 on the CPU motherboard using the 8 wire harness with eight-position Molex minifit connector (provided).
 2. Make sure the 10 way, right angle header, connector P3 on the CPU is secured to J1 on the next motherboard to the left. Repeat this for the third (leftmost) motherboard, and on if applicable.
-

Card Interconnections Within Expansion Bays

The power distribution interface (PDI) mounted to the back of each expansion cabinet carries 24V Card power and data to each 4"x 5" card.

Refer to "Step 7: Installing Modules into Expansion Bays (4100U)" for instructions on mounting 4"x 5" cards to the PDI. Also bear in mind the following variations:

- In a remote expansion cabinet, a transponder interface card (TIC) requires additional interconnections. This occurs in MINIPLEX systems. Refer to Chapter 3.
 - Regular motherboards require non-PDI interconnections to each other and to the CPU. Refer to "Step 5: Installing Modules into Expansion Bays (4100U)."
-

Basic Bay-To-Bay Interconnections

The 4 wire harness 734-008 is used to carry 24V Card power and coms from bay to bay. Connector P1 on the PDI receives power from the previous PDI or from P6 on the SPS (or alternatively from P7, P8 on the CPU Motherboard). P2 on the PDI is used to carry power and coms to a 64/64 Controller. P3 is used to carry power and coms to the next PDI.

Jumpers P4 and P5 on the PDI are set to positions 2-3 (right) to provide card power to the bay only if an XPS is fitted to the PDI. Jumpers P4 and P5 are set to positions 1-2 (left) to provide card power to the bay from P1 on the PDI.

Note: Interconnections can become more involved if 4100 motherboards are used. Refer to "Step 5: Installing Modules into Expansion Bays (4100U)" if this is the case.

Continued on next page

Step 4. Interconnecting Modules and Bays, *Continued*

Basic Bay-To-Bay Interconnections (continued)

Figure 2-7, below, shows the interconnections between three bays in a host panel.

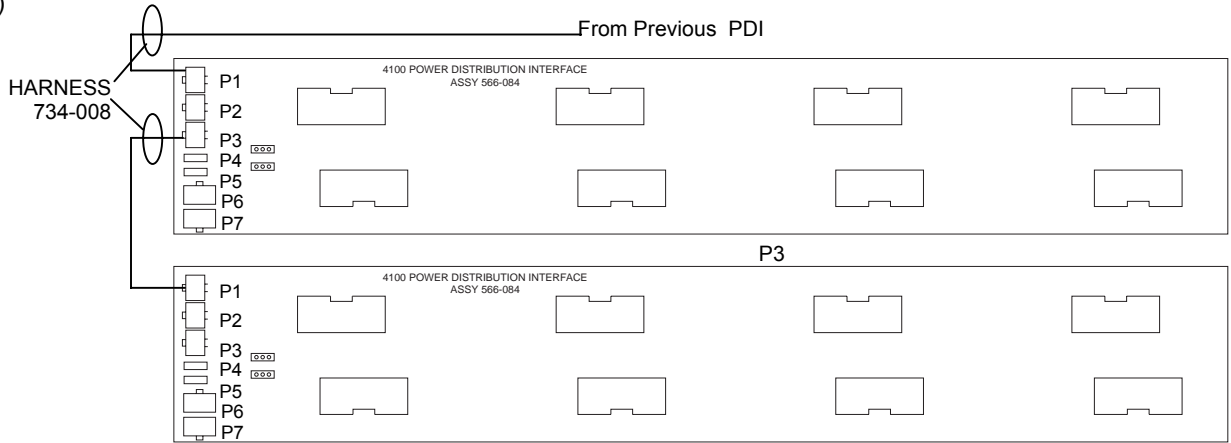

Figure 2-7. Bay-to-Bay Interconnections

Connecting to Motherboards

Panels with motherboards on the left side of the expansion bays require some non-PDI connections. If you need to connect a harness to a motherboard, refer to Figure 2-8 and follow these steps. Make sure to route the power and communication wiring on the left side of the bay.

1. Connect one end of the 733-525 Harness to a motherboard in an adjacent bay.

If the adjacent bay is a CPU bay with no additional motherboards, connect the harness to the P8 and P7 connectors of the CPU motherboard.

- Insert the harness connector with the blue wire into the P8 connector. Note that the P8 connector has eight pins. Insert the harness connector on either the top four pins or the bottom four pins, not in the middle.
- Insert the harness connector with the white wire into the P7 connector. Note that the P7 connector has eight pins. Insert the harness connector on either the top four pins or the bottom four pins, not in the middle.

If the adjacent bay is an expansion bay or a CPU bay with additional motherboards, connect the harness to the P2 and P3 connectors of the motherboard installed in the leftmost slot. Connect the harness as follows:

- Insert the harness connector with the blue wire into the P2 connector. Note that the P2 connector has eight pins. Insert the harness connector on either the top four pins or the bottom four pins, not in the middle.
- Insert the harness connector with the white wire into the P3 connector. Note that the P3 connector has eight pins. Insert the harness connector on either the top four pins or the bottom four pins, not in the middle.

Continued on next page

Step 4. Interconnecting Modules and Bays, *Continued*

Connecting to Motherboards (*continued*)

2. Connect the other end of the harness to the leftmost motherboard in the next bay, as described below. Make sure to route the wiring on the left side of the bay.
 - Insert the harness connector with the blue wire into the P2 connector. Note that the P2 connector has eight pins. Insert the harness connector on either the top four pins or the bottom four pins, not in the middle.
 - Insert the harness connector with the white wire into the P3 connector. Note that the P3 connector has eight pins. Insert the harness connector on either the top four pins or the bottom four pins, not in the middle.

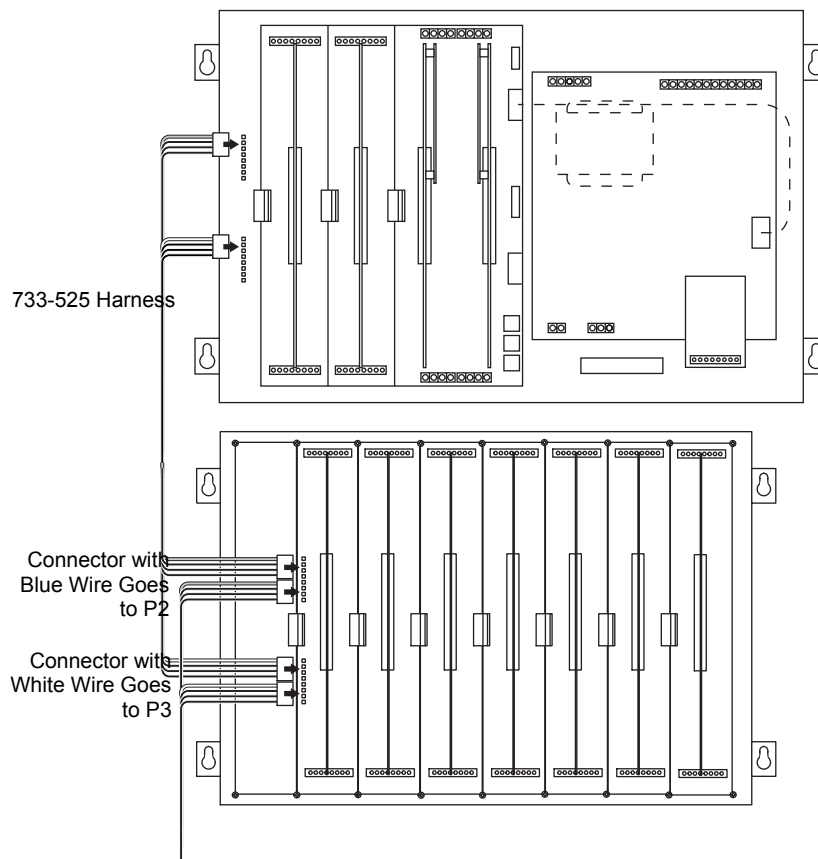

Figure 2-8. Power and Communication Wiring for Motherboards

Step 5. Installing Modules into Expansion Bays (4100U)

Overview

This section contains guidelines and instructions on installing 4" x 5" cards and traditional motherboards into 4100U card bays.

IMPORTANT: This section applies to aftermarket modules for expansion bays only. If you do not need to install any aftermarket modules at all, and if you have followed Steps 1 through 6, you have completed the panel installation and can apply AC power.

Placement Guidelines

Refer to the following guidelines before mounting 4" x 5" cards and/or motherboards to an expansion bay.

- Each expansion bay assembly includes a chassis, two end supports, one LED/switch frame, and a power distribution interface (PDI) board.
- An expansion bay holds up to eight 4" x 5" modules. A double-size module, such as the expansion power supply (XPS), takes up two blocks of space as shown below. The Australian SPS takes up four blocks of space (note, the double sized XPS is not currently available for Australia).
- Cards should be added from right to left if an XSPS is fitted.

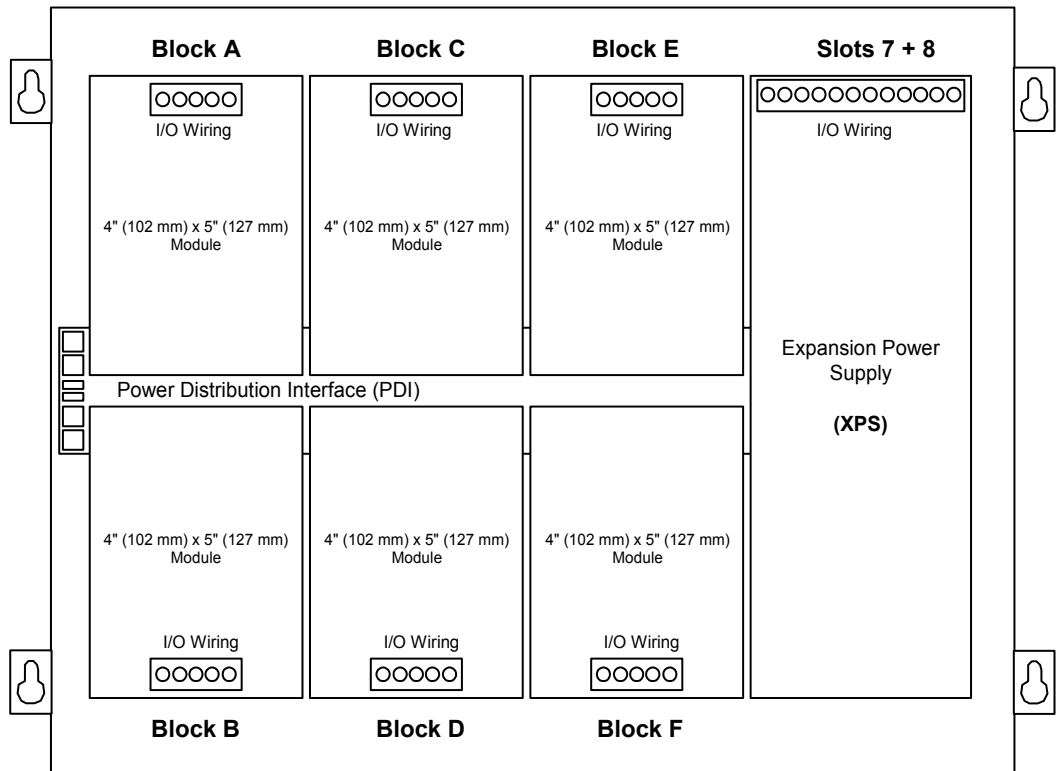

(Note. Australian SPS is 4 slots wide. XPS is not available in Australia.)

Figure 2-9. Expansion Bay 4" x 5" Card Placement

Continued on next page

Step 5. Installing Modules into Expansion Bays (4100U), *Continued*

Placement Guidelines (continued)

- Motherboards can be installed on top of the PDI in expansion bays. The data and power that would normally be bussed via the PDI is instead routed across the boards via ribbon cable from one board to the next.
- Up to eight 2" (51 mm) x 11 1/2" (292 mm) motherboards can be installed in an expansion bay **if no 4" x 5" modules are installed in the bay, and if the pins on the left connector (usually P1) on the leftmost motherboard are removed.** Motherboards are mounted on top of the PDI in expansion bays. The data and power that would normally be bussed via the PDI is instead routed across the boards via ribbon cable from one board to the next.
- Motherboards should be added from left to right.
- Relay motherboards must be the rightmost motherboards.
- In the first bay of an FACP, the CPU motherboard is the right most motherboard, and other motherboards are fitted to its left side.
- The CPU motherboard generates the 8V supply required for 4100A motherboards. It also has the 4100A style Molex connectors to which a harness can be fitted as per Fig 2-8.

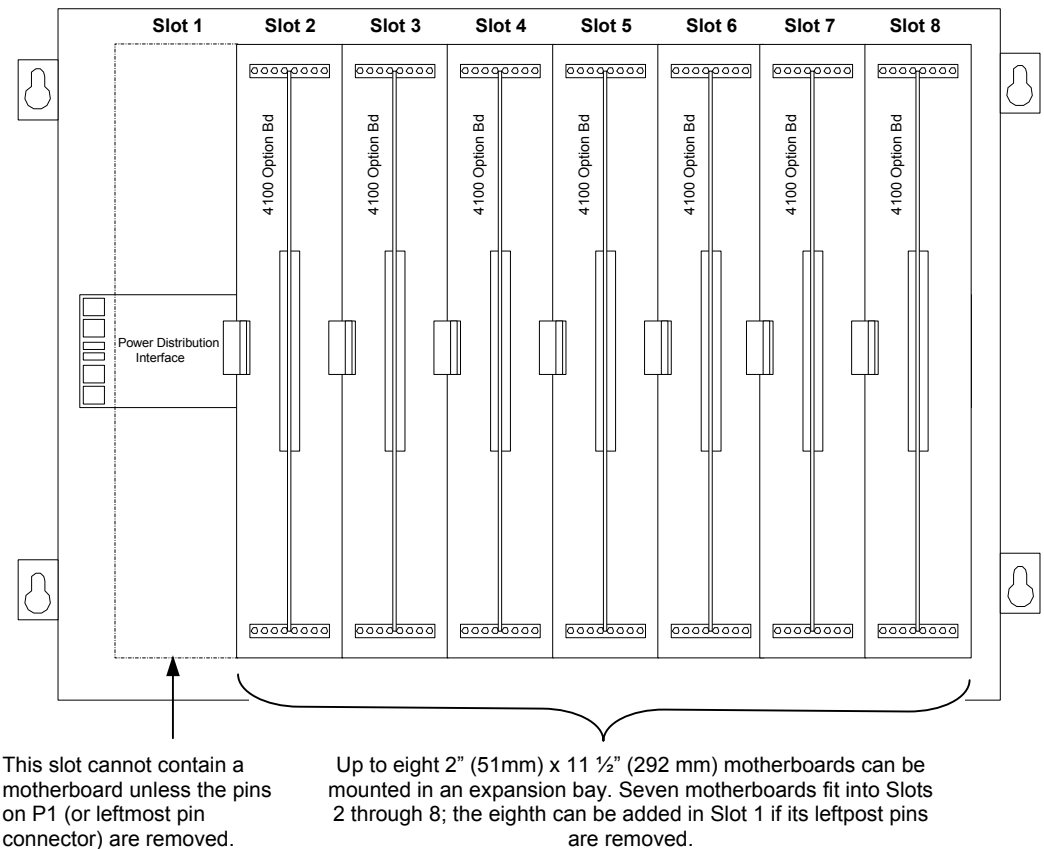

Figure 2-10. Expansion Bay Motherboard Placement

Continued on next page

Step 5. Installing Modules into Expansion Bays (4100U), *Continued*

Placement Guidelines (continued)

- As shown in the figure below, motherboards can be installed alongside 4"x 5" cards, if necessary.

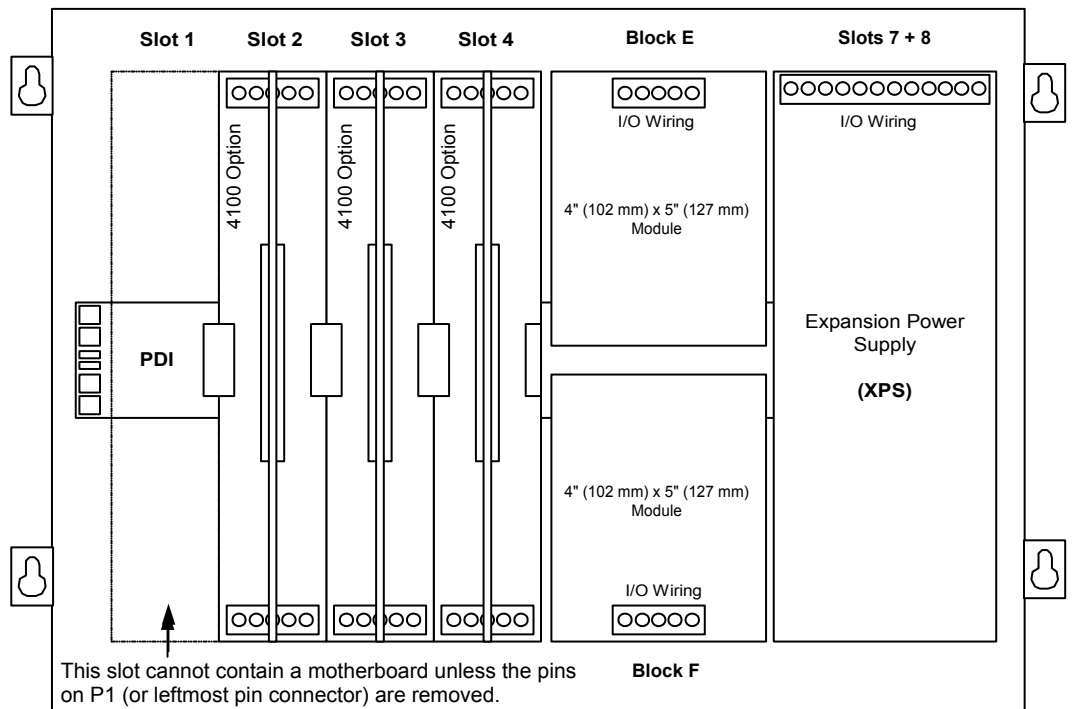

(Note. Australian SPS is 4 slots wide. XPS is not available in Australia.)

Figure 2-11. Mixed Module Placement

Continued on next page

Step 5. Installing Modules into Expansion Bays (4100U), *Continued*

Installing 4" X 5" Cards

The power distribution interface (PDI) is mounted to the back of each expansion cabinet. The PDI contains slots for up to eight 4"x 5" slave cards. Since the PDI carries power and data across the entire bay, it solves most interconnection issues, especially between 4"x 5" cards.

Use the following instructions and the figure below to mount 4"x 5" slave cards to an expansion cabinet.

1. Screw two standoffs and washers to the appropriate holes in the back of the cabinet. These holes must line up with the screw holes in the 4"x 5" card. See Figure 3-24.
2. Plug the 4"x 5" card into the appropriate blind mating connector. Seat the card firmly onto the PDI when installing to ensure complete insertion of the power connector into the PDI.
3. Secure the top of the card to the standoffs with two #6 torx screws and washers.

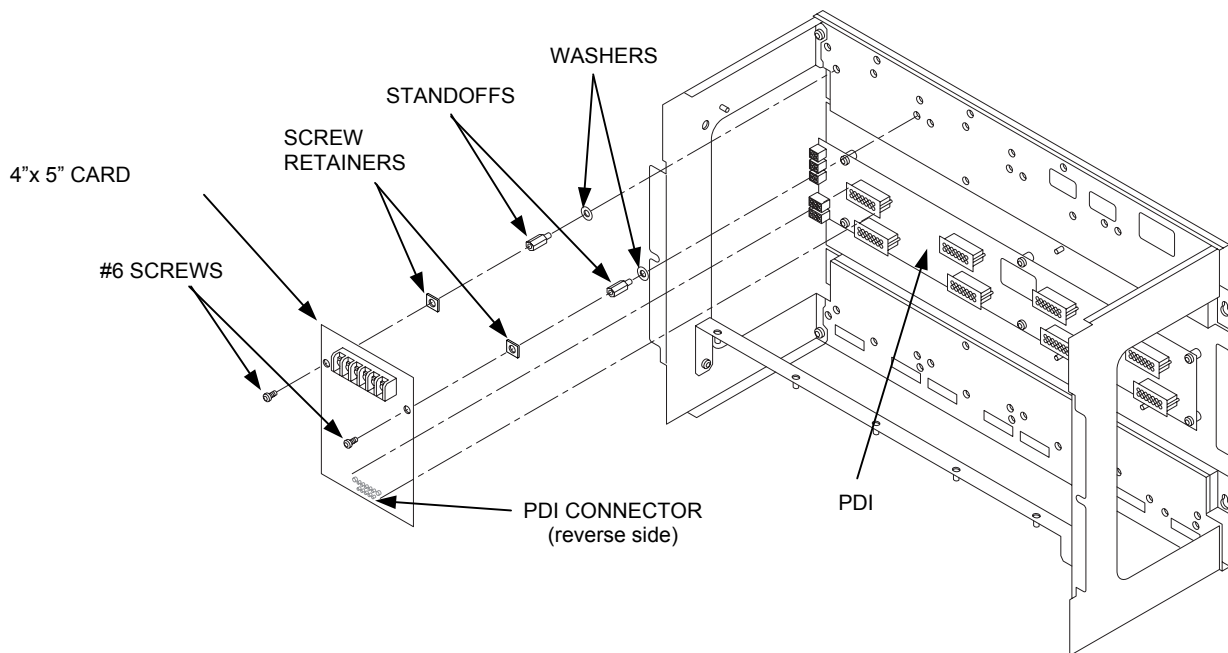

Figure 2-12. Slave Card/PDI Connection

Continued on next page

Step 5. Installing Modules into Expansion Bays (4100U), *Continued*

Installing Motherboards

Use the following procedure when installing motherboards in an expansion bay. Start with the second slot from the left and fill to the right. The mounting items are available as KT0468.

1. Orient the motherboard with the connector labeled J1 on the right and the header labeled P1 on the left.
2. Attach four metal threaded standoffs and lockwashers into the screw holes on the chassis.
3. Attach two grey plastic standoffs to the motherboard socket mounting screws.
4. Secure the motherboard to the standoffs using four #6 torx screws as shown below.

WARNING: Note that a 4100 Motherboard with daughter card cannot be fitted directly behind a 64/64 LED/Switch Controller. The same applies to the modules made on the bay mounting bracket (FA2255), e.g. ME0426 T-Gen.

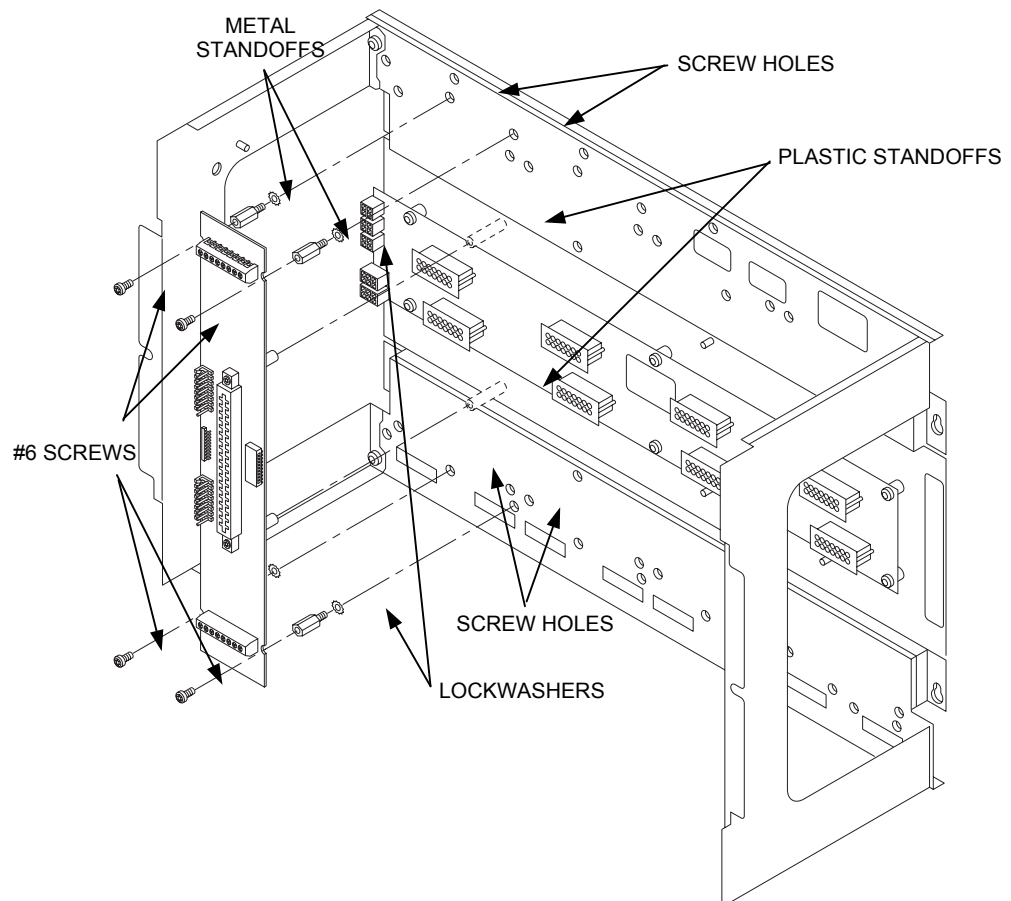

Figure 2-13. Installing the Motherboard in a 4100U Expansion Bay

Step 6. Installing LED/Switch Modules into Expansion Bays (4100U)

Overview

The LED/switch user interface consists of a variety of modules, mounted to the front of an expansion bay, which are configured via the 4100 Programmer. Each display module contains between 8 and 24 switches and LEDs, each one separately configurable.

User interface functionality is driven by the 64/64 LED/Switch Controller Card, which mounts behind two of the display modules (typically in positions 3 and 4). The varieties of modules are as follows:

- 4100-1288 LED/Switch Controller Card with mounting plate.
- 4100-1289 LED/Switch Controller Card (no mounting plate; mounts on extra space of 4100-1288).
- 4100-1280 8-Switch/8-LED Display Card. With red LEDs.
- 4100-1281 8-Switch/8-LED Display Card. With yellow LEDs.
- 4100-1282 8-Switch/16-LED Display Card. With one red and one yellow LED per switch.
- 4100-1283 8-Switch/16-LED Display Card. With two yellow LEDs per switch.
- 4100-1284 8-Switch/16-LED Display Card. With one red and one green LED per switch.
- 4100-1285 16-Switch/16-LED Display Card. With red LEDs.
- 4100-1286 Hands Off Auto (HOA) Switch Display Card. Provides 24 switches and 24 LEDs. The HOA uses an overlay to group every 3 switches together, denoting on, off, and automatic control of smoke control components. For every group of 3 switches, there are 3 LEDs (green-red-green).
- 4100-1287 24-Switch/24-LED Display Card. With red LEDs.
- 4100-1279 2" Blank display cover module to cover empty front panel space
- 4100-1294 Slide-In Label Kit - one per 4100U cabinet
- 4100-1276 8-Pluggable LEDs with 8 red LEDs
- 4100-1277 16-Pluggable LEDs with alternating red and yellow LEDs
- 4100-1278. 16-Switch/16-LED with alternating red and yellow LEDs, one per switch
- 4100-1295 Hands Off Auto (HOA) switch display card. Provides 24 switches and 24 red LEDs.
- 4100-1296 8-Switch/16 LED Display Card. With one green and one yellow LED per switch.
- 4100-9843 Pluggable LED Kit, 8 Yellow LEDs
- 4100-9844 Pluggable LED Kit, 8 Green LEDs
- 4100-9845 Pluggable LED Kit, 8 Red LEDs
- ME0456 Fan Control Module

Continued on next page

Step 6. Installing LED/Switch Modules into Expansion Bays (4100U), Continued

The LED/Switch User Interface

Below is an illustration of a LED/switch bay from the user's perspective.

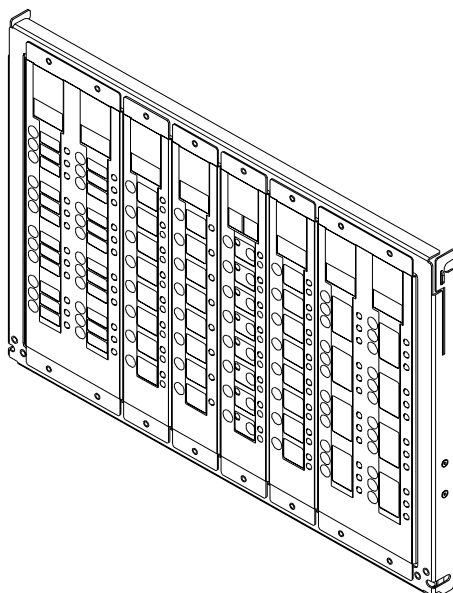

Figure 2-14. LED/Switch Modules

LED/Switch Controller Card

The LED/switch controller card is a 4100 slave that mounts behind two LED/switch modules. The LED/switch controller handles up to 64 switches and 64 LEDs on the modules and communicates their status to the 4100 CPU. When a button is pressed on a module, the controller acknowledges the signal and reacts according to how that switch was configured via the 4100 Programmer.

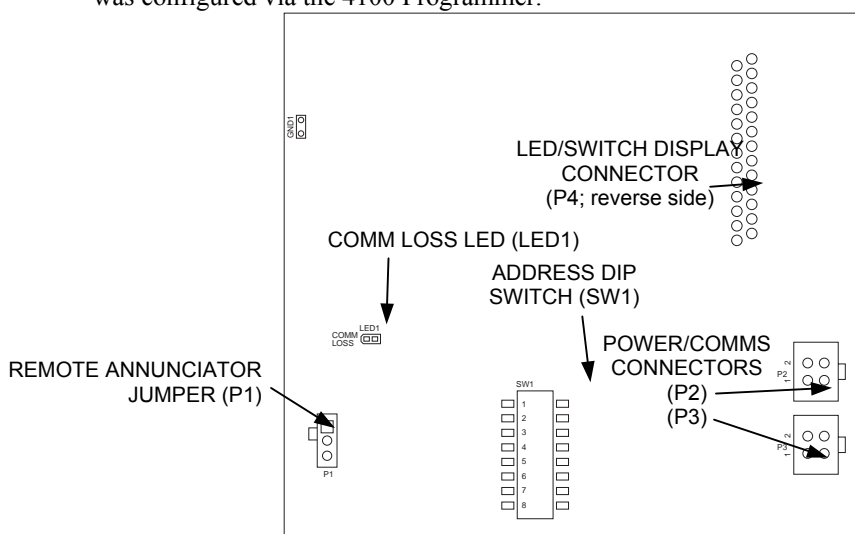

Figure 2-15. LED/Switch Controller

Continued on next page

Step 6. Installing LED/Switch Modules into Expansion Bays (4100U),

Continued

LED/Switch Controller Card, (continued)

If more than 64 LEDs or 64 switches are used, a second controller may be installed.

LED 1. This LED illuminates if communication loss between the controller and the CPU occurs. It is independent of jumper P1 (which configures different communication loss features).

LED/Switch Modules

All types of modules are mounted to the front of a bay, and are connected to each other via a ribbon cable. Each module operates by the same rules: when a button is pressed, the controller card sends the CPU the information, and the event programmed for that button occurs.

Configuring the LED/Switch Controller Card

The 64/64 LED/switch controller requires physical configuration, but the LED/Switch modules do not. Configuration consists of setting jumper P1 and setting the device address. Device Address is covered in Appendix A.

Activating the Communication Loss Feature

If the LED/switch controller is used in a remote annunciator, it can make the LED/Switch modules announce a communication loss condition. If communication loss occurs when this setting is activated, LED 1 of the first connected display card illuminates, and the piezo on the LED/switch controller sounds. The indication is silenced via the corresponding switch (switch 1 on the first display card).

Use jumper port P1 to activate or deactivate the communication loss feature.

- Position 1 - 2 deactivates the feature (default).
 - Position 2 - 3 activates the communication loss feature.
-

Continued on next page

Step 6. Installing LED/Switch Modules into Expansion Bays (4100U), Continued

Mounting LED/Switch Modules to the Expansion Bay

Refer to the figure below to mount the display cards to the front of the expansion box.

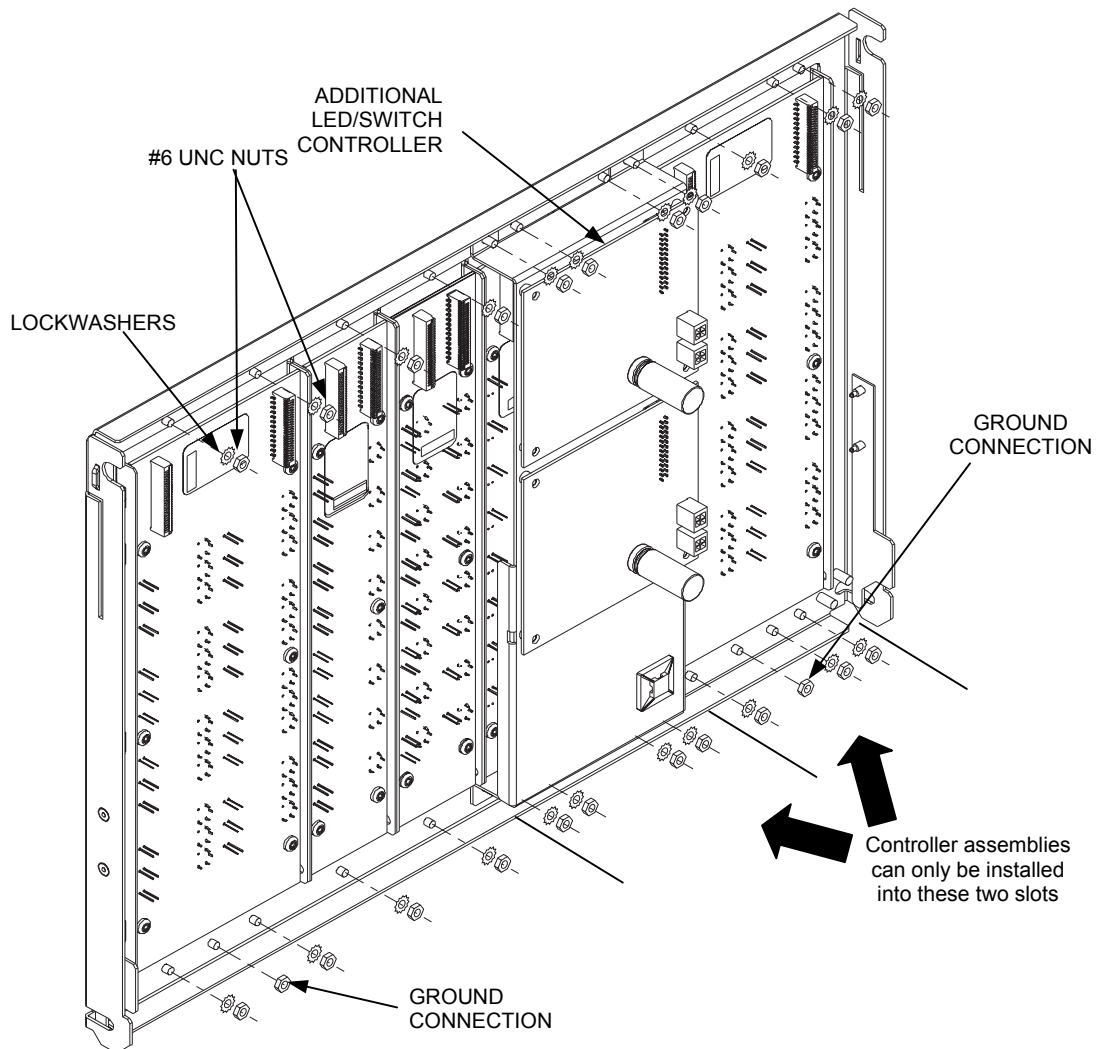

Figure 2-16. LED/Switch Card Mounting

Continued on next page

Step 6. Installing LED/Switch Modules into Expansion Bays (4100U), Continued

Mounting the Controller Card Assembly

Refer to the figures and instructions below to mount the controller card assembly to the back of one of the LED/switch cards.

4. Use four 322-123 Nuts and four 268-009 Washers to secure the 637-141 Bracket to the inside front of the expansion box. Note that there are only two locations where the bracket can be mounted, as shown in Figure 2-16.
5. Attach the header connector on the back side of the controller (P4) to the connector on the back side of one of the LED/switch modules.
6. Secure the controller card to the board using four #6 screws, as shown in Figure 5.

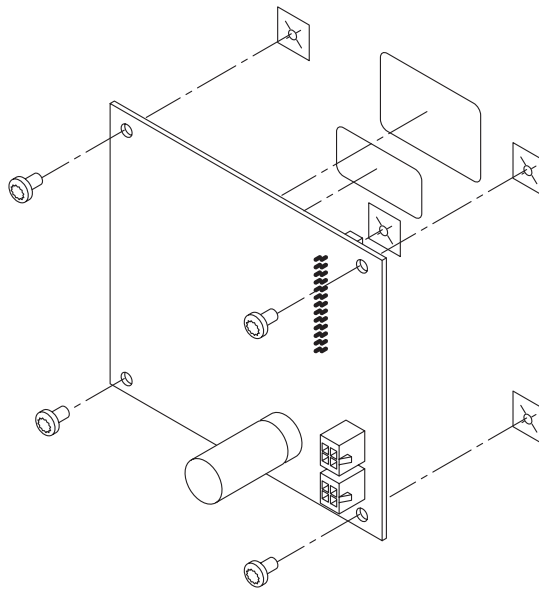

Figure 2-17. Controller Card Mounting

WARNING: The 64/64 Controller Card cannot be mounted directly in front of a 4100 Motherboard or a Bay mounting bracket such as one that mounts a T-Gen.

Changing Display Card LEDs

The 4100-1276 LED display card contains eight red LEDs and the 4100-1277 card contains 16 alternating red/yellow LEDs. The LED colors may be configured differently, as described in this section.

Only the following LEDs are to be used to change color configurations. LEDs are available in sets of eight, as follows:

- 4100-9843 (yellow)
- 4100-9844 (green)
- 4100-9845 (red)

Continued on next page

Step 6. Installing LED/Switch Modules into Expansion Bays (4100U), *Continued*

Changing Display Card LEDs, *(continued)*

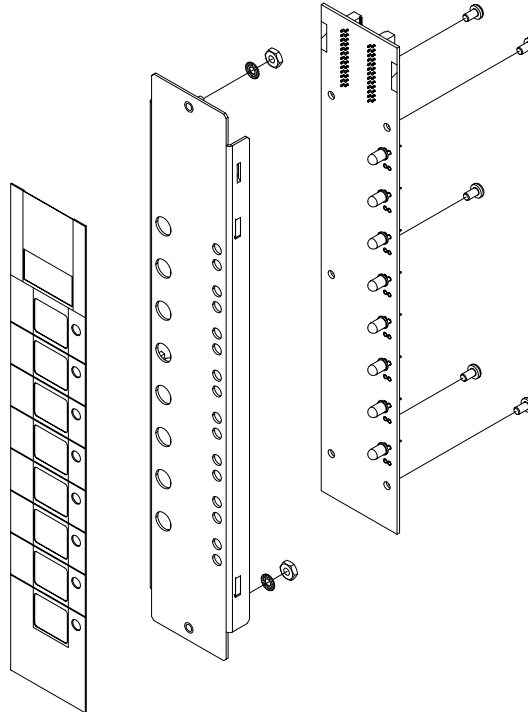

Figure 2-18. Assembling / Disassembling the LED Display Card

Interconnecting Cards

User interface wiring consists of connecting the LED/switch controller card to the expansion bay's power distribution interface (PDI), and connecting display cards to each other. This section describes both procedures.

Continued on next page

Step 6. Installing LED/Switch Modules into Expansion Bays (4100U), Continued

Wiring Instructions

The following directions are complete instructions on interconnecting display cards and connecting the controller card to a power source.

1. Use Harness 734-008 to connect P2 on the controller card to one of the 4-pin connectors on the PDI.
2. If there are multiple controller cards, use Harness 734-036 to connect P3 on the controller card to P2 on another controller card.
3. Interconnect all LED/switch display cards with the ribbon cables (provided). Connector P1 is the input; connector P2 is the output.

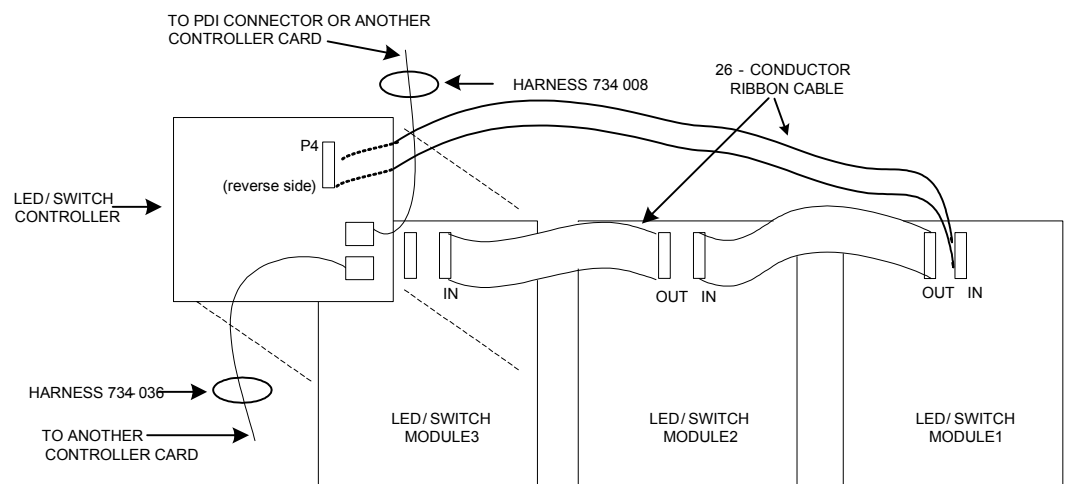

Figure 2-19. LED/Switch Controller Wiring

The Terminal Block Utility Module (4100U)

Overview

The 4100-0632 Terminal Block Utility Module is an all-purpose terminal block that mounts to an expansion bay, above or below the power distribution interface (PDI). Each module utilizes one block of mounting space.

The terminal block utility module has two 16-position terminal blocks that accept up to a maximum of 12 AWG (3.309 mm²) wire.

Mounting to the Electronics Bay

Follow the directions below to mount the terminal block utility module to the electronics bay.

1. Align the terminal block utility module to any two compatible screw holes on the electronics bay. Position the higher terminal block towards the middle of the bay. There are eight possible locations: four above and four below the PDI. Refer to the figure, below.
2. Secure the terminal block utility module to the electronics bay with two #6 screws and lockwashers.
3. The shorting strip may be removed or modified, depending on the application.

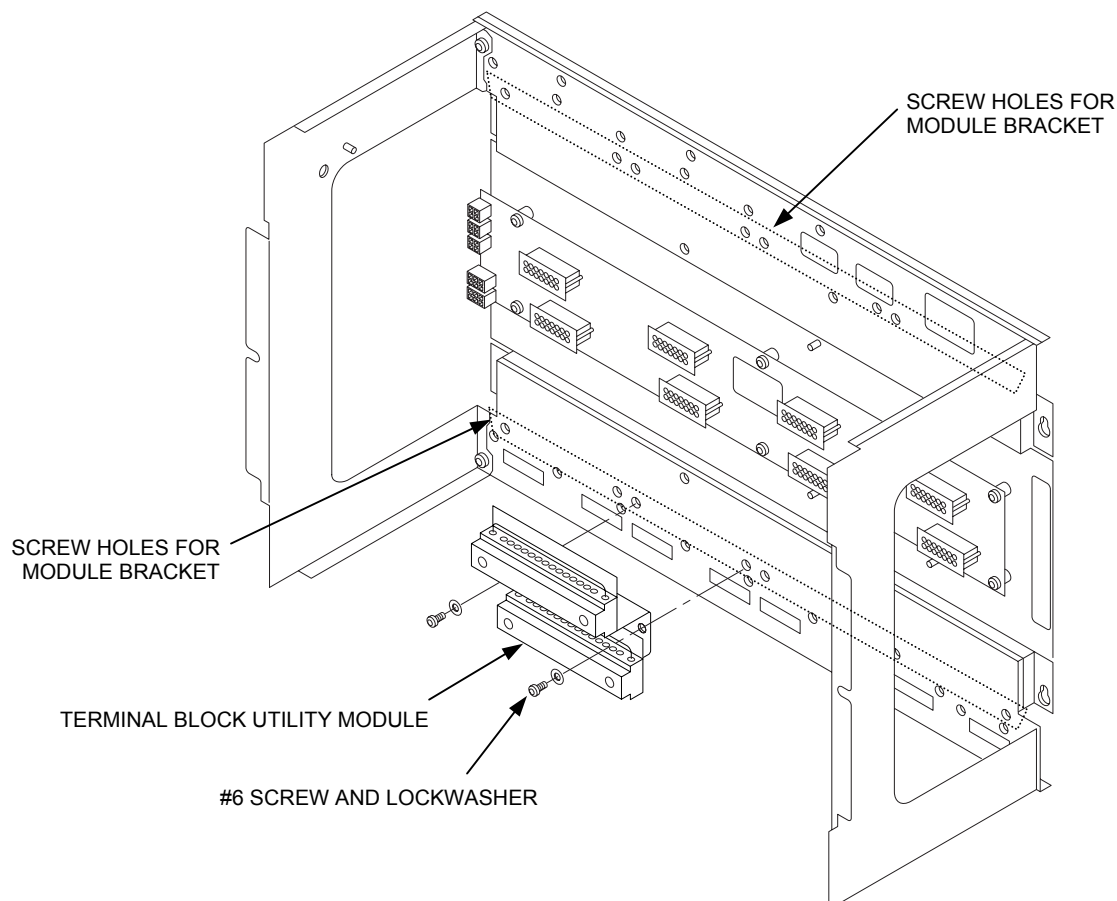

Figure 2-20. Terminal Block Utility Module Mounting

Chapter 3

Installing 4100 MINIPLEX Components (Non-4100U)

Introduction

4100 host panel and remote locations. This chapter describes the transponder installation procedure for all MINIPLEX systems in non-4100U systems.

In this Chapter

Refer to the page number listed in this table for information on a specific topic.

Topic	See Page #
Introduction to MINIPLEX Systems (Non-4100U)	3-30
MINIPLEX System Components (Non-4100U)	3-32
MINIPLEX System Guidelines (Non-4100U)	3-34
Installing Modules into Cabinets (Non-4100U)	3-35
MINIPLEX Wiring (Non-4100U)	3-39

Introduction to MINIPLEX Systems (Non-4100U)

Overview

The 4100 MINIPLEX Fire Alarm System uses transponder cabinets containing remote interface cards (RICs) to extend power and communication across large areas. MINIPLEX transponders allow the system to provide applications for up to 1000 monitor and/or control points and 2000 annunciator points (see note). Using 4100-style serial communications, up to 31 distributed MINIPLEX transponder locations are possible for initiating device circuit cards, MAPNET II/TrueAlarm addressable communications interfaces, notification appliance circuit cards, LED/switch controls, auxiliary relay control cards, power supplies, and audio amplifiers.

By selecting the required combinations of modules and mounting MINIPLEX transponders at the appropriate building locations, wire quantities are significantly reduced for all monitor and control functions. Since power for the local modules is provided from the local power supply, the wiring from the control panel need only be separate twisted, shielded pairs for data, voice, and telephone.

Notes:

- One point consists of one LED or one switch on an LED/switch module, one LED driver output on a graphic driver, or one switch input on a graphic switch input module.
- Up to 32 modules can be controlled by one MINIPLEX transponder.

Continued on next page

Introduction to MINIPLEX Systems (Non-4100U), *Continued*

Overview (Continued)

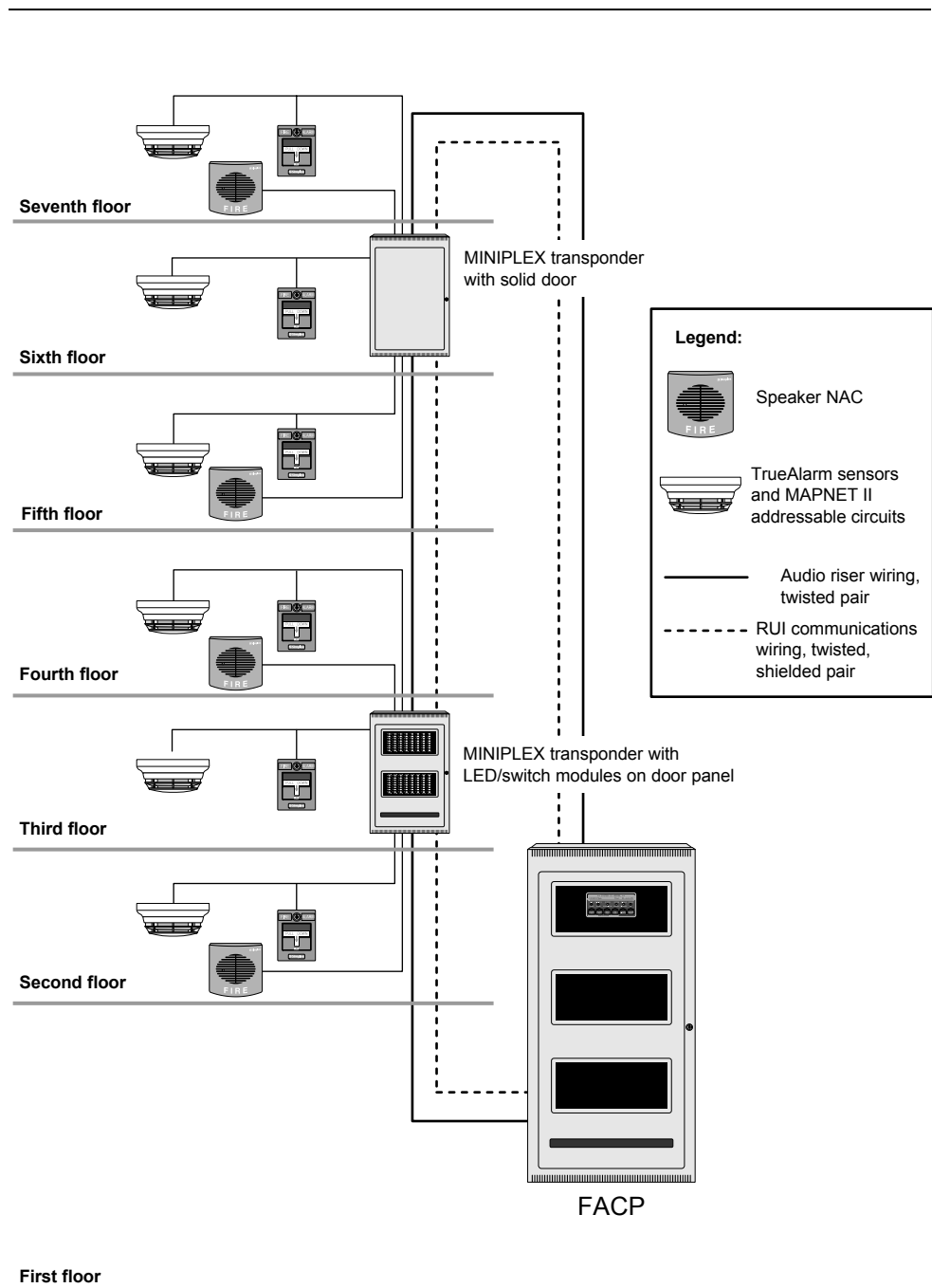

Figure 3-1. MINIPLEX System Design

MINIPLEX System Components (Non-4100U)

Overview

The 4100 MINIPLEX system is comprised of a host panel containing everything required in a standalone cabinet (see Chapter 2), plus:

- An RUI module in the master controller bay
- One or more remote MINIPLEX transponder cabinets
- A RIC II card in each transponder cabinet

This section describes each component in turn.

The RUI Card

The RUI module consists of a motherboard and daughter card, which are used in the master controller bay of a MINIPLEX system to extend the length of communications wire to reach remote bays.

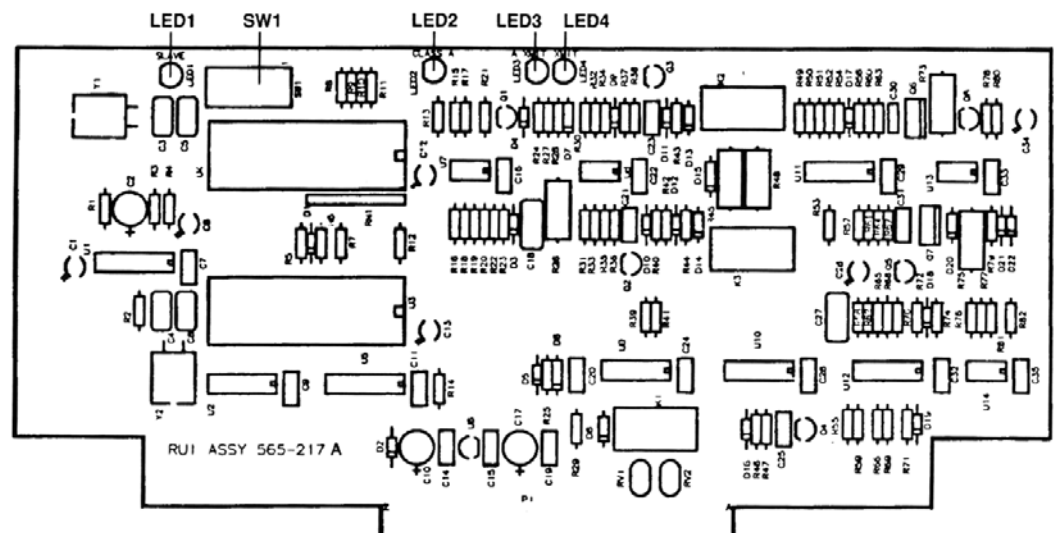

Figure 3-2. The Remote Unit Interface Card

The RUI card mounts onto a 562-799 or 562-856 Motherboard.

Transponder Cabinets

Communication wiring from the RUI module in the host panel extends to the RIC II card in a remote transponder cabinet.

Continued on next page

MINIPLEX System Components (Non-4100U), *Continued*

The Remote Interface Card (RIC)

Remote interface cards (RICs) in the transponder cabinets allow for data, power, and audio interconnections between the 4100 host panel and remote locations. They support RUI connections in Style 4 and Style 7 wiring configurations.

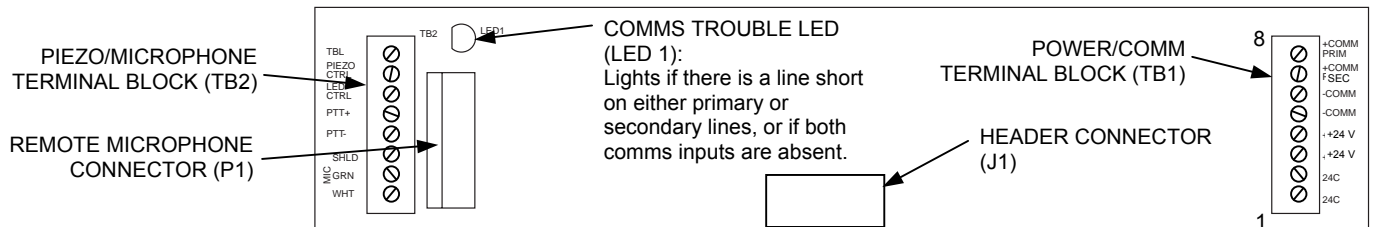

Figure 3-3. The RIC II Card

MINIPLEX System Guidelines (Non-4100U)

Overview

The rules on this page apply exclusively to MINIPLEX systems. Review each guideline before installing a MINIPLEX 4100 system.

Guidelines

- The Style 4 RUI card supports MINIPLEX transponders *and* 4602/4603 serial annunciators on the same signaling line circuit.
 - Up to 4 RUI cards in the 4100 Control Panel can be used for distributing transponder wiring in different directions or for supporting different wiring requirements (such as using a Style 7 RUI for serial annunciators).
 - Up to 31 MINIPLEX transponders can be controlled from the 4100 Control Panel, and can be distributed as required among the RUI cards.
 - “T” tapping is not allowed unless less than 40 detectors/addressable devices are connected to the MINIPLEX.
 - Wiring from RUI cards is a minimum of 18 AWG (0.75sqmm) twisted, shielded pair.
 - The maximum wiring distance from the 4100 RUI card to a MINIPLEX transponder is 2500 feet (762 m). For Style 4 wiring, this can be extended to 10,000 feet (3 km) maximum if “T” tapping is used.
-

Installing Modules into Cabinets (Non-4100U)

Overview

This section contains guidelines and instructions for mounting the RUI and RIC II modules into 4100 cabinets.

- The RUI motherboard mounts into the CPU bay or, if necessary, an expansion bay.
- The RIC II mounts into expansion bays only.

Guidelines

Review the following guidelines before installing a motherboard into a cabinet.

- If a power supply is installed in the bay, it must be installed on the far right of the bay and any relay modules must be installed in the slots immediately to its left.
- Relay cards **must be installed in the rightmost possible slots**. This is necessary to allow for the proper routing of non-power limited wiring, which could be connected to a relay module.

Installing the RUI Motherboard

Mount the RUI motherboard (562-799 or 562-856) in a master controller bay as described below.

1. Orient the motherboard with the connector labeled J1 on the right and the header labeled P1 on the left.
2. Match the connector on the previously installed motherboard with the pins on the motherboard you are installing. Slide the motherboard to the left until the pins are completely inserted in the connector of the previously installed motherboard. If you are installing the leftmost board, the pins will remain unconnected.
3. Secure the motherboard to the chassis with four torx screws.

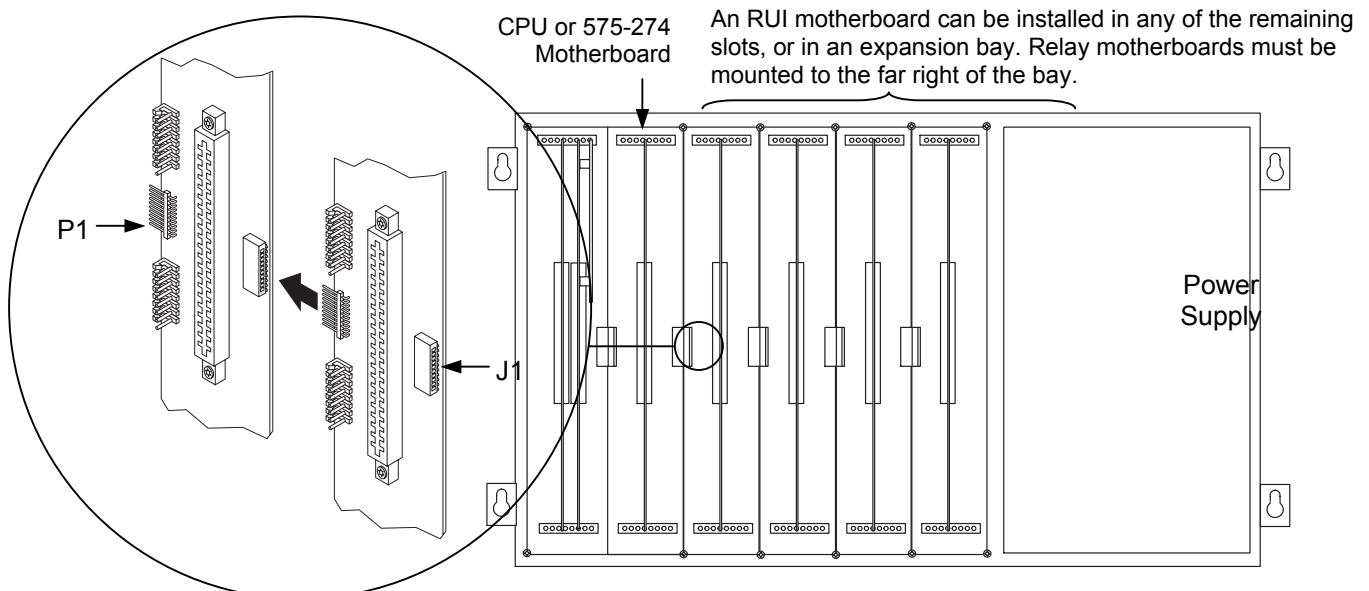

Figure 3-4. Installing the RUI Motherboard in the CPU Bay

Note: RUI motherboards may also be installed in expansion bays. Refer to “Step 5: Installing Motherboards into Expansion Bays (Non-4100U)” in Chapter 2 for instructions.

Continued on next page

Installing Modules into Cabinets (Non-4100U), *Continued*

Installing the RIC II Motherboard

The RIC II motherboard is installed into a remote transponder cabinet. Review the following guidelines before mounting RIC II motherboard.

- If a power supply is installed in the bay, it must be installed on the far right of the bay and any relay modules must be installed in the slots immediately to its left.
- Relay cards must be installed in the rightmost possible slots. This is necessary to allow for the proper routing of non-power limited wiring (typically 120 VAC wiring), which could be connected to a relay module.

Use the following directions and Figure 3-5 to install a RIC II motherboard into a transponder cabinet.

1. The RIC II motherboard must be installed in the leftmost slot. Orient the motherboard with the connector labeled J1 on the right.
2. Secure the motherboard to the chassis with four torx screws.

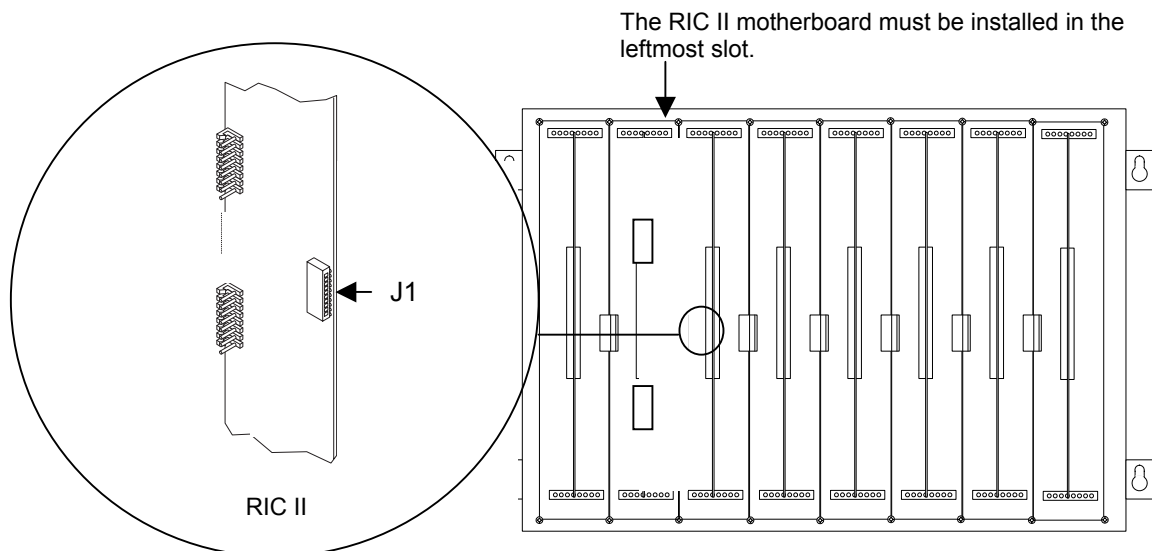

Figure 3-5. Installing the RIC II Motherboard into a 4100 Expansion Bay

3. If you are installing the RIC II in a transponder cabinet with additional bays, you must connect a 733-525 Power and Communication Harness. Continue to the next topic for instructions.

Continued on next page

Installing Modules into Cabinets (Non-4100U), *Continued*

Connecting the 733-525 Harness

If you need to connect a 733-525 Harness to a motherboard, refer to Figure 3-6 and follow these steps. Make sure to route the power and communication wiring on the left side of the bay.

1. Connect one end of the harness to a motherboard in an adjacent bay.

If the adjacent bay is a master controller bay, connect the harness to the P2 and P3 connectors of the master controller motherboard and continue to step 2.

If the adjacent bay is an expansion bay, connect the harness to the P2 and P3 connectors of the motherboard installed in the leftmost slot. Connect the harness as follows:

 - a. Insert the harness connector with the blue wire into the P2 connector. Note that the P2 connector has eight pins. Insert the harness connector on either the top four pins or the bottom four pins, not in the middle.
 - b. Insert the harness connector with the white wire into the P3 connector. Note that the P3 connector has eight pins. Insert the harness connector on either the top four pins or the bottom four pins, not in the middle.
2. Connect the other end of the harness to the leftmost motherboard in the next bay, as described below. Make sure to route the wiring on the left side of the bay.
 - a. Insert the harness connector with the blue wire into the P2 connector. Note that the P2 connector has eight pins. Insert the harness connector on either the top four pins or the bottom four pins, not in the middle.
 - b. Insert the harness connector with the white wire into the P3 connector. Note that the P3 connector has eight pins. Insert the harness connector on either the top four pins or the bottom four pins, not in the middle.

Continued on next page

Installing Modules into Cabinets (Non-4100U), *Continued*

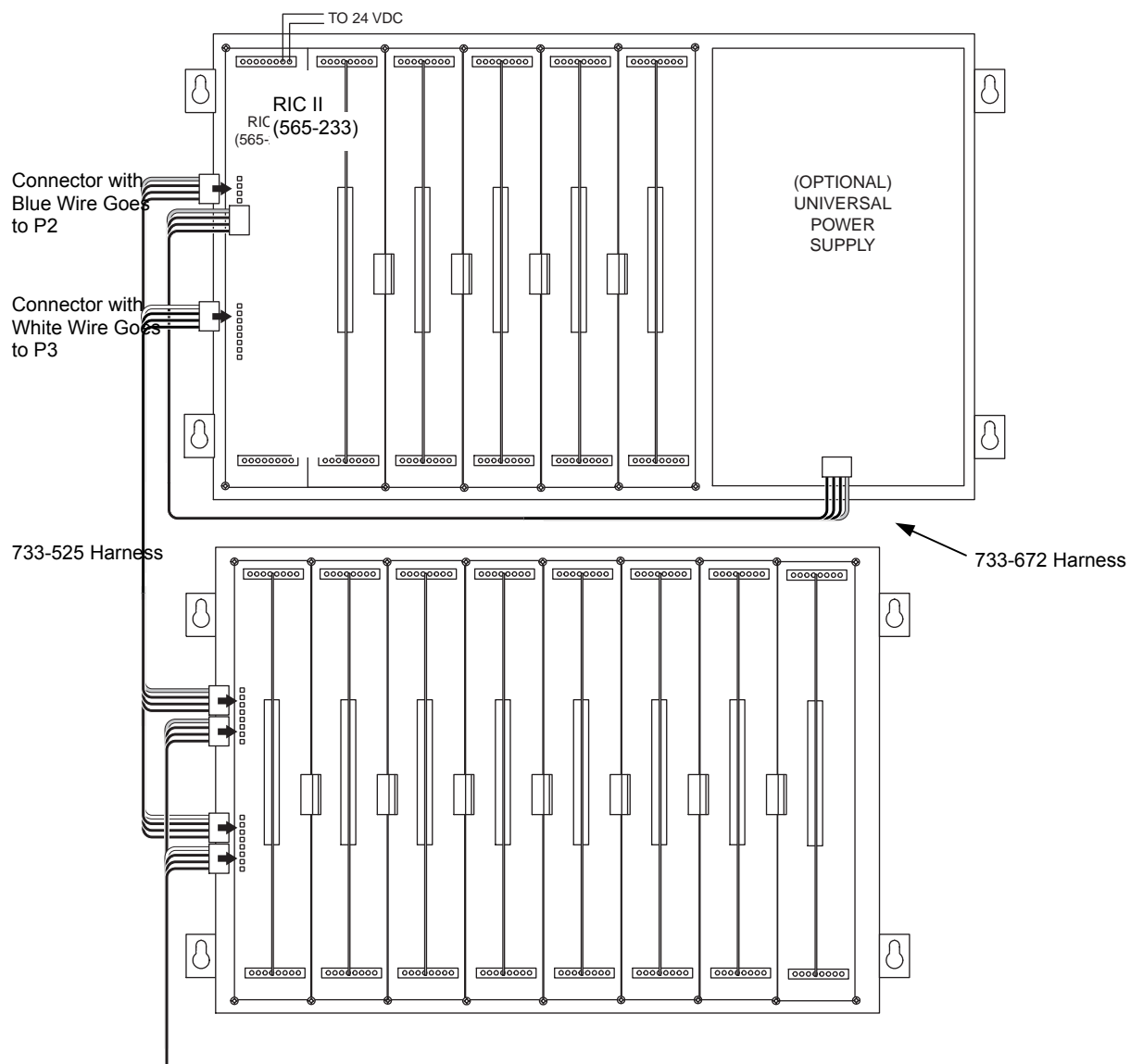

Figure 3-6. Power and Communication Wiring for the Transponder Cabinet (4100)

MINIPLEX Wiring (Non-4100U)

Overview

The RIC must be connected to the host panel via RUI cabling. This section explains how to wire the two together, and how to set up a system with multiple transponders connected to the same host panel.

Wiring Configurations

RUI cabling can be accomplished either through Class A or Class B wiring.

Class A wiring allows transponder cabinets to communicate with the FACP even in the event of an open circuit somewhere in the loop. Class A wiring requires that two wires are routed from the CPU motherboard to each RIC, and then back again to the CPU motherboard.

Class B wiring allows “T” tapping, and therefore requires less wiring distance per installation than Class A. Additionally, Class B wiring does not require end-of-line resistors, because each RIC communicates directly to the CPU.

Make sure these prerequisites are accounted for before wiring:

- AS1670 allows the loss of a maximum of 40 detectors/addressable devices to be caused by a single fault.
- All transponder cabinets are installed within 2500 feet (762 m) of the FACP.
- Conductors test free of all grounds.
- All wires are between 12 (3.309 mm²) and 18 AWG (0.8321 mm²), or as the local code dictates.

Class A Wiring

To connect the RUI card to RICs using Class A wiring, read the following instructions and refer to Figure 3-7, on the next page.

1. Route wire between 0.75 mm² and 4 mm² from the + (TB1-8) and - (TB1-6) terminals on the Comms “A” block of the 562-856/565-217 RUI card to the TB1-8 (+) and TB1-6 (-) terminals on the 565-233 RIC.
2. Route wire from the first RIC to the next one. Repeat for each transponder cabinet within 2500 feet (762 m).
3. Route wire from TB1-7 (+) and TB1-5 (-) on the last RIC to + (TB1-4) and - (TB1-2) on the Comms “B” block of the 562-856/565-217 RUI card.

Class B Wiring

To connect the RUI card to RIC II cards using Class B wiring, read the following instructions and refer to Figure 3-7, on the next page.

1. Route wire between 0.75 mm² and 4 mm² from the + (TB1-8) and - (TB1-6) terminals on the Comms “A” block of the 562-856/565-217 RUI card to the TB1-8 (+) and TB1-6 (-) terminals on the 565-233 RIC.
2. Route wire from the first RIC to the next one. Repeat for each transponder cabinet within 2500 feet (762 m).

Continued on next page

MINIPLEX Wiring (Non-4100U), *Continued*

Wiring Illustration

The illustration below applies to Class A and Class B wiring.

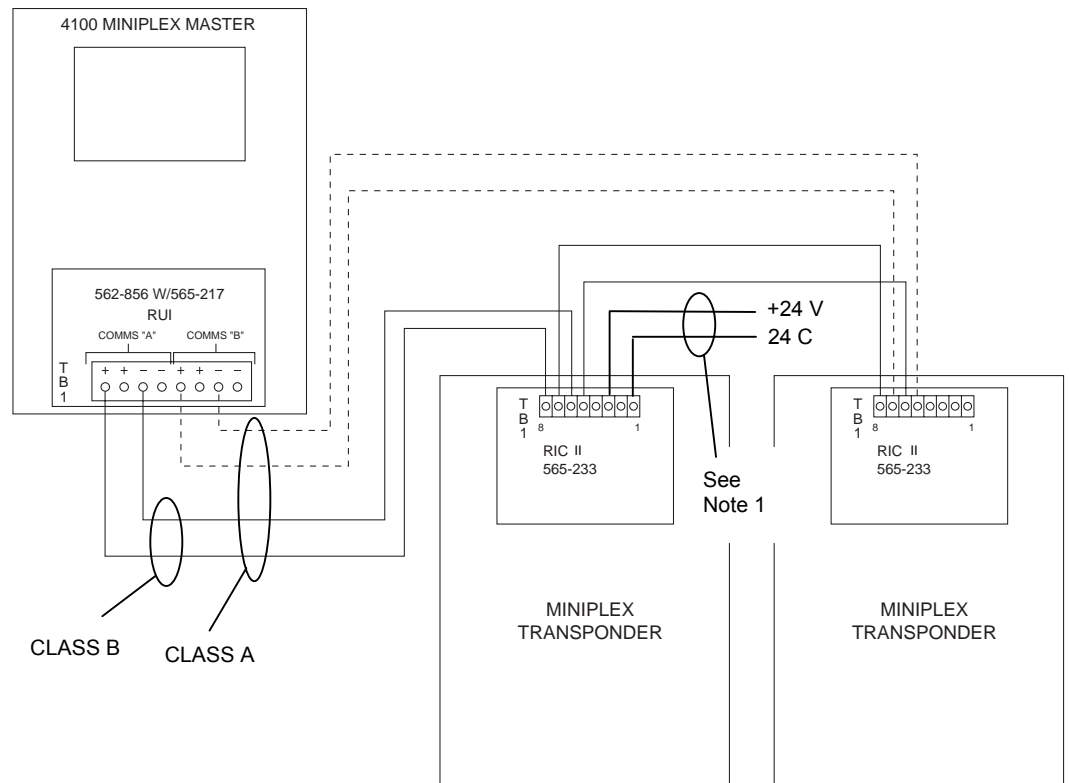

Figure 3-7. MINIPLEX Wiring

Notes:

1. Power wiring is not shown. Connect the RIC II card to the UPS or expansion power supply in the transponder cabinet.
2. If a UPS is not provided in the transponder cabinet, then 24 V must be provided from the host panel.
3. Maintain correct polarity on terminal connections. Do not loop wires under terminals.
4. All wiring is supervised and power limited.

Chapter 4

Installing 4100U MINIPLEX Components

Introduction

MINIPLEX transponder interface cards (TICs) allow for data and power interconnections between the 4100 host panel and remote locations. This chapter describes the transponder installation procedure for 4100U MINIPLEX systems.

In this Chapter

Refer to the page number listed in this table for information on a specific topic.

Topic	See Page #
Introduction to MINIPLEX Transponders	4-2
MINIPLEX System Guidelines	4-7
Configuring Cards	4-8
TIC/Riser Mounting (4100U)	4-9
TIC/Motherboard Interconnections (4100U)	4-10
RUI Wiring (4100U)	4-11

Introduction to MINIPLEX Transponders (4100U)

Overview

The 4100U MINIPLEX system is comprised of a host panel containing everything required in a standalone cabinet (see Chapter 1), plus:

- One or more remote MINIPLEX transponder cabinets
- A transponder interface card (TIC) in each transponder cabinet

This section describes each component in turn.

Transponder Cabinets

RUI Communication wiring from the RUI module in the host panel extends to a transponder interface card (TIC) in a remote transponder cabinet. The transponder cabinet has at least one TIC module in it, and can have one, two, or three bays.

Transponder Interface Cards (TICs)

The following TICs, audio risers, and audio riser controller modules are available for 4100U and/or 4100U MINIPLEX ® systems:

- Basic Transponder Interface Card (TIC) Module
- Local Mode TIC Module (not currently available in Australia)

Transponder Interface Cards (TICs) receive data from 4100U host panels allowing remote locations to perform fire alarm functions. TIC modules are optionally available with local mode operation that provides basic (degraded mode) system functions in the event of a communication loss with the master panel. TICs receive communications from the 4100U host panel using Remote Interface (RUI) communications with either Style 4 or Style 7 wiring.

Basic TICs

The basic TIC is an addressable device that contains an RUI input, and a port for connecting to other transponder modules.

The basic TICs use the same board, with some variations:

- The basic TIC is an addressable device that contains RUI outputs, an audio riser output, a user interface output, and a port for connecting to motherboards.
-

Continued on next page

Introduction to MINIPLEX Transponders (4100U), *Continued*

**The Local Mode TIC
(Not currently
available in
Australia).**

The local mode TIC contains an RUI input, port for connecting to other transponder modules, and terminal block for connecting to an optional Local Mode Controller. Local Mode Controllers are mounted remotely from the transponder. Installation instructions are supplied with the controller.

Local mode operation allows a TIC to provide life safety operations in the event of a communication loss with the master controller. More specifically, this provision means that fire alarm inputs and outputs within the transponder cabinet can still work in a limited capacity to allow continued functioning of local initiating devices and notification appliances connected to the TIC. Local mode is considered a “degraded” mode of operation because full fire alarm system functionality is not guaranteed.

Because the TIC is a slave module that occupies an RUI address, it can indicate a trouble condition to the master controller in the event of a hardware failure. When local mode is initiated, all slave devices locally connected to the TIC are notified by the TIC that local mode is taking effect. From that point until communication is restored to the master controller, the TIC

”group-polls” all connected local slaves, and the slaves respond only in the event of an alarm input activation. Other status changes, including troubles, are not reported.

Continued on next page

Introduction to MINIPLEX Transponders (4100U), *Continued*

TIC Illustrations

Below is an illustration of the various TIC and audio riser circuit boards.

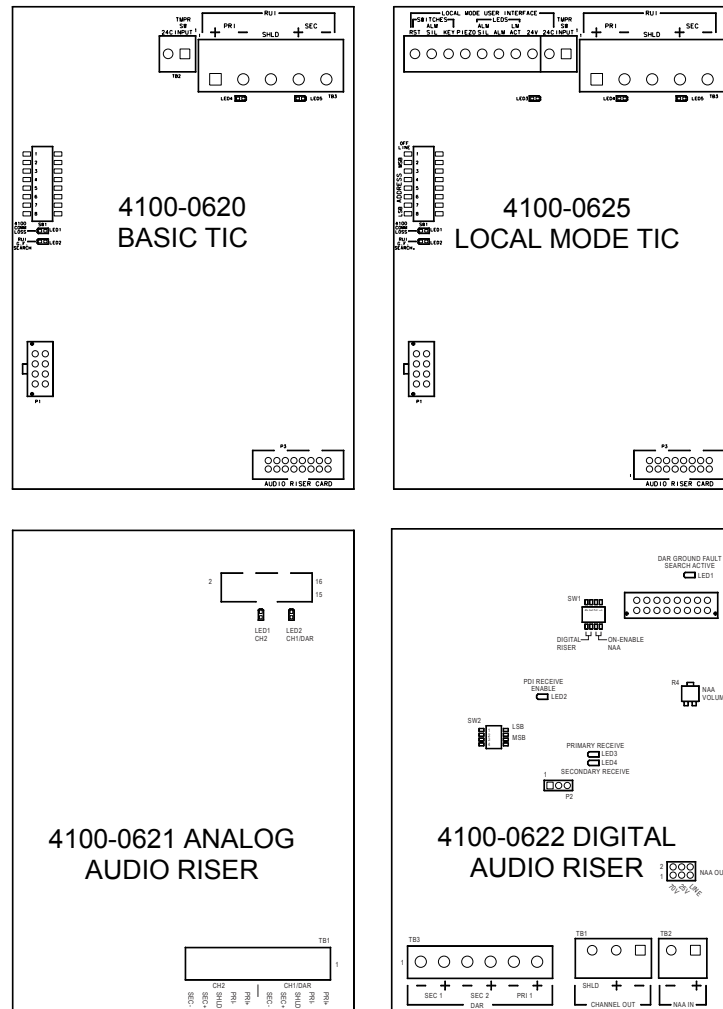

Figure 4-1. Transponder Interface Cards

Note, the audio risers are not approved for use in Australia.

Continued on next page

Introduction to MINIPLEX Transponders (4100U), *Continued*

Local Mode Specifications

Local mode is supported by the following:

- 4100-3101/3104/3105 IDNet Card
- 4100-5101/5102/5103 Expansion Power Supply NACs (including TrueAlert Non-Addressable SmartSync appliances)
- 4100-5111/5112/5113 System Power Supply NACs (including TrueAlert Non-Addressable SmartSync appliances)
- 4100-5125/5126/5127 Remote Power Supply NACs (including TrueAlert Non-Addressable SmartSync appliances)
- 4100-5120/5121/5122 TrueAlert Power Supply NACs
- 4100-1214 to -1225, 4100-1228 to -1239, 4100-1314 to -1325, 4100-1328 to -1339, 100 W Amplifier NACs
- 4100-1212/1213/1226/1227/1312/1313/1326/1327 Flex 50 Amplifier NACs
- 4009-9401 TrueAlert Addressable Controller
- 4100-1270 Phone Controller and 4100-1272/1273 Phone NAC cards
- 4009-9201/ 9301 IDNet NAC Extender
- 4100-5116 Expansion Signal Card

Local mode is NOT supported by, but can co-exist with, the following:

- 4100 Legacy cards
- 4100-3101 to -3103 Auxiliary Relay Cards
- 4100-6048 VESDA™ Interface Kit
- 4100-6043/6044 RS-232/2120 Interfaces
- 4100-1280 to -1287 LED/Switch Annunciators
- 4100-1290 24-Point Graphic I/O Module
- 4602-9101 SCU/ 4602-9102 RCU
- 4603-9101 LCD Annunciator
- 4100-1210/1211/1311 Audio Controller Board
- 4100-6014 Network Interface Card
- 4100-6052 DACT

Bear in mind the following limitations for when local mode is in effect:

- If an alarm is already activated when local mode is initiated, the alarm remains activated in local mode.
- Software zones are not supported. Basic TrueAlert channels are supported.
- Alarm verification is not supported. All alarms are reported immediately.
- SMPL is not supported.
- TrueAlarm sensors have fixed thresholds.

Continued on next page

Introduction to MINIPLEX Transponders (4100U), *Continued*

LEDs

The TICs have the following LEDs:

LED1. Illuminates to indicate communication loss with the CPU.

LED2. Illuminates when an RUI ground fault search is active.

LED3. Illuminates when Local Mode is active.

LED4. Illuminates to indicate an RUI Style 7 primary trouble.

LED5. Illuminates to indicate an RUI Style 7 secondary trouble.

Refer to Figure 5-1 to see which LEDs are included on which TIC. Most TICs do not contain all LEDs.

Card Specifications

Table 5-1 lists the specifications for all TICs.

Table 5-1. TIC Specifications

Electrical Specifications	
Input Voltage	18-33 VDC
Output Voltage	8 V @ 1 A; 100 mV p-p ripple
Input Current	87 mA for all TICs. 112 mA for a local mode TIC connected to a local mode annunciator.
Environmental Specifications	
Operating Temperature	32° to 120° F (0° to 49° C)
Humidity	10% to 93% relative humidity at 90° F (32° C)

MINIPLEX System Guidelines (4100U)

Overview

The rules on this page apply exclusively to MINIPLEX systems. Review each guideline before installing a MINIPLEX 4100U system.

Guidelines

- All wiring is 18 AWG (0.8231 mm²) (minimum) and 12 AWG (3.309 mm²) (maximum).
 - All wiring is supervised and power-limited.
 - All wiring that leaves the building requires overvoltage protection. Install module inside an UL-Listed electrical box wherever wire enters or exits the building. A maximum of four 2081-9044 Modules may be connected to one channel. The 2081-9044 is rated for 200 mA (maximum).
 - AS1670 allows the loss of a maximum of 40 detectors/addressable devices to be caused by a single fault.
 - For Style 4 operation:
 - The maximum distance to any device is 2,500 feet (762 m).
 - “T” taps are allowed.
 - The total maximum distance (including all “T” taps) is 10,000 feet (3,048 m).
 - Maximum allowed line-to-line capacitance (“+” to “-” terminals) is 0.58 uF. For applications with shielded wire, be sure that the total capacitance from line to line plus the shield to either line is no more than 0.58 uF.
 - For Style 6 or Style 7 operation, the maximum loop distance is 2,500 feet (762 m). “T” taps are not allowed.
 - RUI comms are wired to remote cabinets from the CPU motherboard to one of the following transponder interface cards: 4100-0620 (566-093) or 4100-0625 (566-094).
 - Annunciators and transponder interface cards support Style 7 operation when the system is wired Class A.
 - The master control panel must be a 4100U Fire Alarm Control Panel.
 - The Style 4 RUI card supports MINIPLEX transponders *and* 4602/4603 serial annunciators on the same signaling line circuit.
 - Up to 4 RUI cards in the 4100U Control Panel can be used for distributing transponder wiring in different directions or for supporting different wiring requirements (such as using a Style 7 RUI for serial annunciators).
 - Up to 31 transponders can be controlled from the 4100U Control Panel, and can be distributed as required among the RUI cards.
-

Configuring Cards (4100U)

Overview

The TIC and all other cards to be mounted in the transponder cabinet and attached expansion bays must be configured to operate correctly in the system via their DIP switch and jumper ports. The CPU motherboard may have to be configured as well.

CPU Motherboard DIP Switch

P9 on the CPU motherboard determines whether the RUI SHIELD signal is connected to 24 C or Earth.

- Position 1 – 2: SHIELD to 24 C (default).
- Position 2 – 3: SHIELD to Earth.

Note: Some devices that connect to RUI have inherently grounded shield terminals, in which case 24 C cannot be used. If 24 C is used, a Negative Ground Fault will occur.

TIC Configuration

The TIC must be assigned a device address via DIP switch SW1. Refer to Appendix A for the address switch table.

Configuring Other Cards

Refer to the appropriate publication to configure other cards that are located in the transponder cabinet and attached expansion bays.

TIC/Riser Mounting (4100U)

Overview

All TICs are mounted like any 4-inch (102 mm) X 5-inch (127 mm) card. This section describes the TIC/audio riser card mounting procedure, which is identical to that of other 4-inch (102 mm) X 5-inch (127 mm) cards.

Mounting Instructions

Use the following instructions and Figure 4-2, below, to mount 4"x 5" slave cards to an expansion cabinet.

IMPORTANT:

- The TIC must be mounted in the upper left position of the bay.
 - The audio riser card must be mounted directly below the TIC.
1. Screw two standoffs and washers to the appropriate holes in the back of the cabinet. These holes must line up with the screwholes in the 4-inch (102 mm) X 5-inch (127 mm) card. See Figure 5-2.
 2. Plug the 4-inch (102 mm) X 5-inch (127 mm) card into the top left PDI connector (P8).
 3. Secure the top of the card to the standoffs with two #6 torx screws and washers.

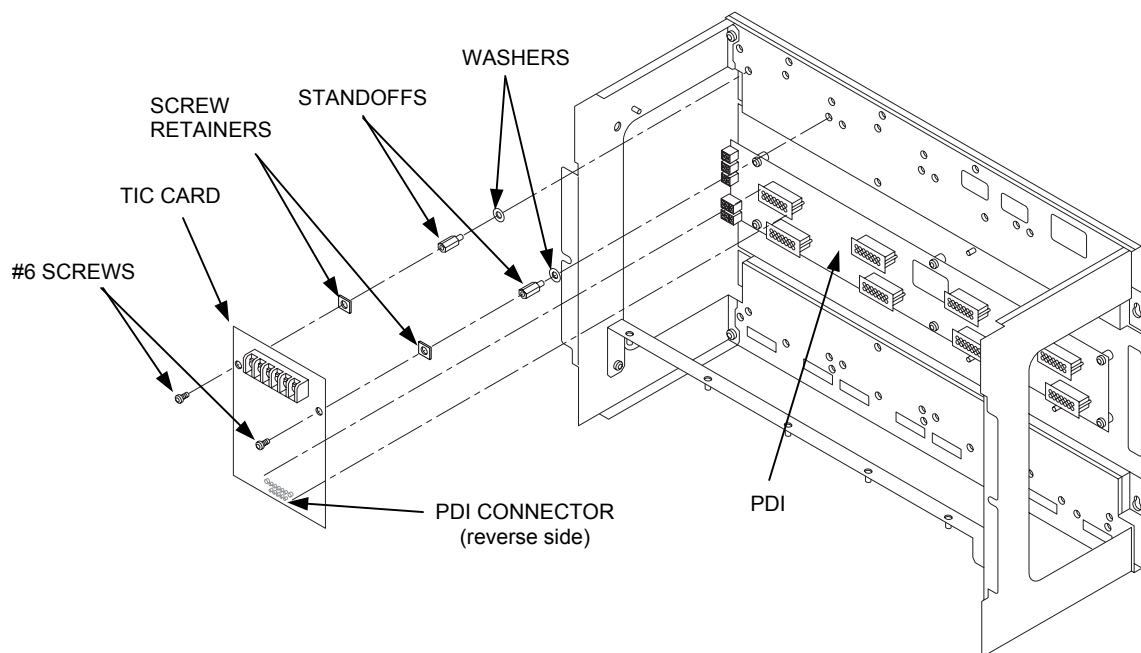

Figure 4-2. TIC Mounting

Continued on next page

TIC/Motherboard Interconnections (4100U)

Use Figure 4-3 to connect the TIC to a motherboard in another bay.

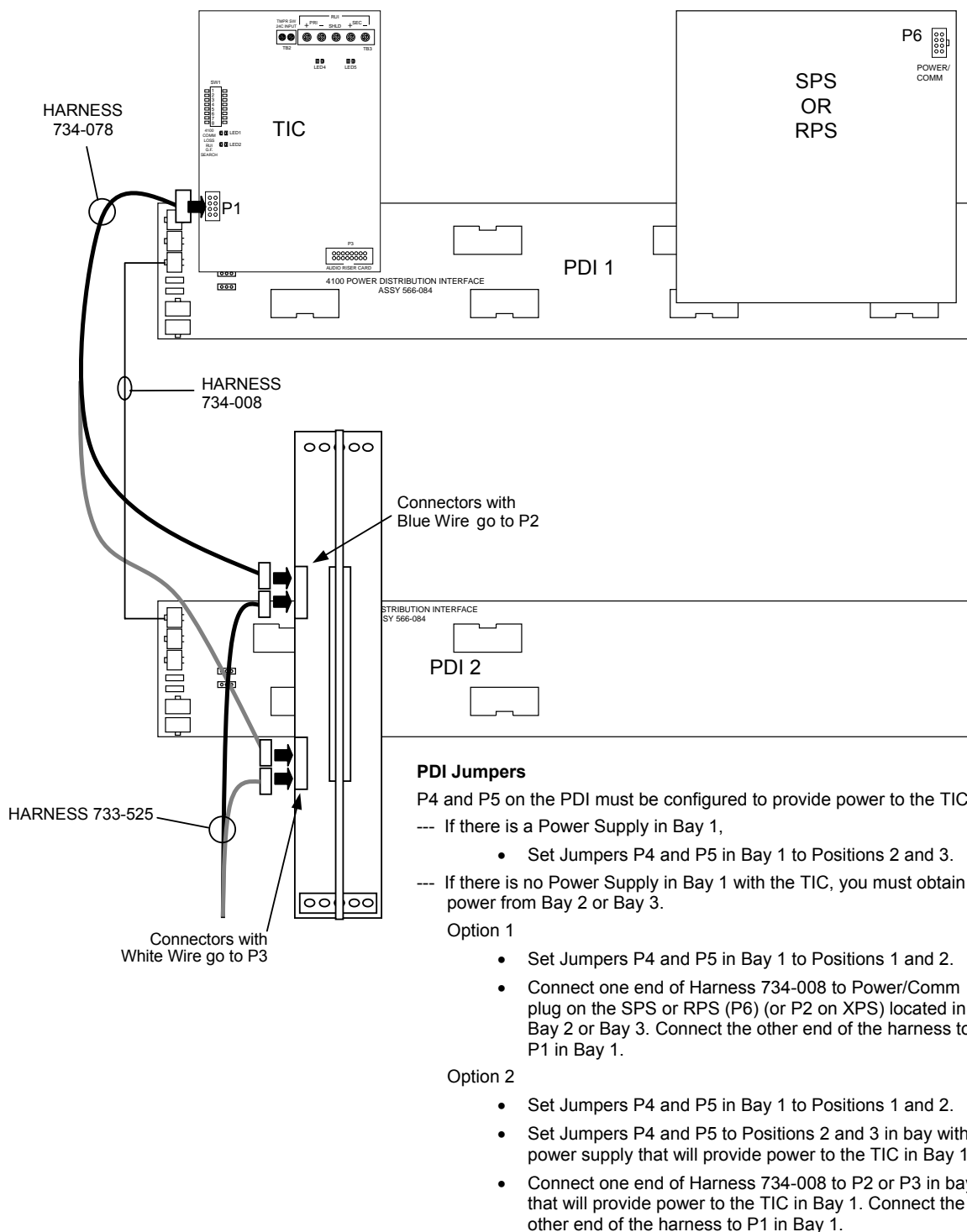

Figure 4-3. Transponder Cabinet Interconnections

RUI Wiring (4100U)

Overview

The TIC must be connected to the host panel via RUI cabling. This section explains how to wire the two together, and how to set up a system with multiple transponders connected to the same host panel.

Wiring Configurations

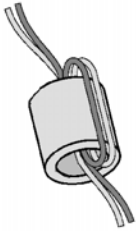

RUI cabling can be accomplished either through Class A or Class B wiring.

Class A wiring allows transponder cabinets to communicate with the FACP even in the event of an open circuit somewhere in the loop. Class A wiring requires that two wires are routed from the CPU motherboard to each TIC, and then back again to the CPU motherboard.

Class B wiring allows “T” tapping, and therefore requires less wiring distance per installation than Class A. Additionally, Class B wiring does not require end-of-line resistors, because each TIC communicates directly to the CPU.

Figure 4-4. The Ferrite Bead

Note: Use supplied ferrite beads with TICs. Loop wires once through the supplied ferrite bead(s) as shown in Figure 4-4.

The illustration below shows both types of wiring.

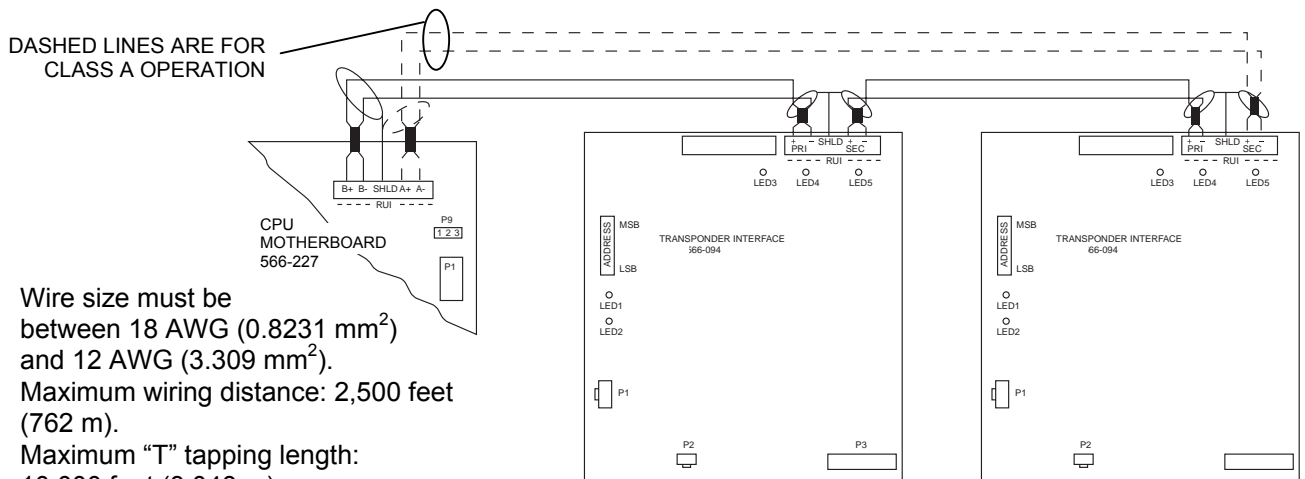

- Wire size must be between 18 AWG (0.8231 mm²) and 12 AWG (3.309 mm²).
- Maximum wiring distance: 2,500 feet (762 m).
- Maximum “T” tapping length: 10,000 feet (3,048 m).
- Maintain correct polarity on terminal connections.
- Do not loop wires under terminals.

Figure 4-5. TIC Wiring to the Host Panel

Continued on next page

Chapter 5 Networking

Introduction

A standalone or MINIPLEX 4100 system becomes a network node when a 4100 Network Interface Card (NIC) or other compatible network card is installed and connected to another network node. How network cards connect to each other depends on the type of media network cards being used.

In this Chapter

Refer to the page number listed in this table for information on a specific topic.

Topic	See Page #
Getting Started	5-2
Introduction to the 4100 Network Interface Card (NIC)	5-3
Step 1. Configuring Network Cards	5-7
Step 2. Mounting Media Cards to the NIC	5-9
Step 3. Mounting Network Cards	5-10
Step 4. Wiring Network Cards	5-11

Getting Started

Overview

This chapter describes how to turn a standalone or MINIPLEX FACP into a network node. This process consists of the following:

Step 1. Configuring cards for operation (using DIP switches and jumper ports)

Step 2. Mounting media cards to the network interface card (NIC)

Step 3. Mounting network cards

Step 4. Wiring network cards

Each step is described in this chapter. Before beginning the installation, review the next few pages for a detailed description of network cards and the media cards that mount onto them.

Introduction to the 4100 Network Interface Card (NIC)

Overview

The Network Interface Card (NIC) is a slave card that uses the standard 4100 serial bus to communicate with the master. The NIC connects FACPs in a network, allowing for communication between each panel via fiber, modem, or twisted shielded pair wire.

The NIC is designed to be connected in a point-to-point arrangement, so that one wire fault does not cause the entire system to fail. The point-to-point arrangement provides the most secure and fault-tolerant wiring possible.

Two types of media boards can be used with the NIC card.

- The Fiber-Optic Media Card can be used for electrically noisy environments or for connecting externally to other buildings.
- The Wired Media Card is used in all other types of applications.

Up to two media boards can be plugged into each NIC. The same NIC can use a combination of two types of media boards (for example, a NIC may have a wired media card connected to port 1 and a fiber-optic media card connected to port 2).

Continued on next page

Introduction to the 4100 Network Interface Card (NIC), *Continued*

Network Module Illustrations

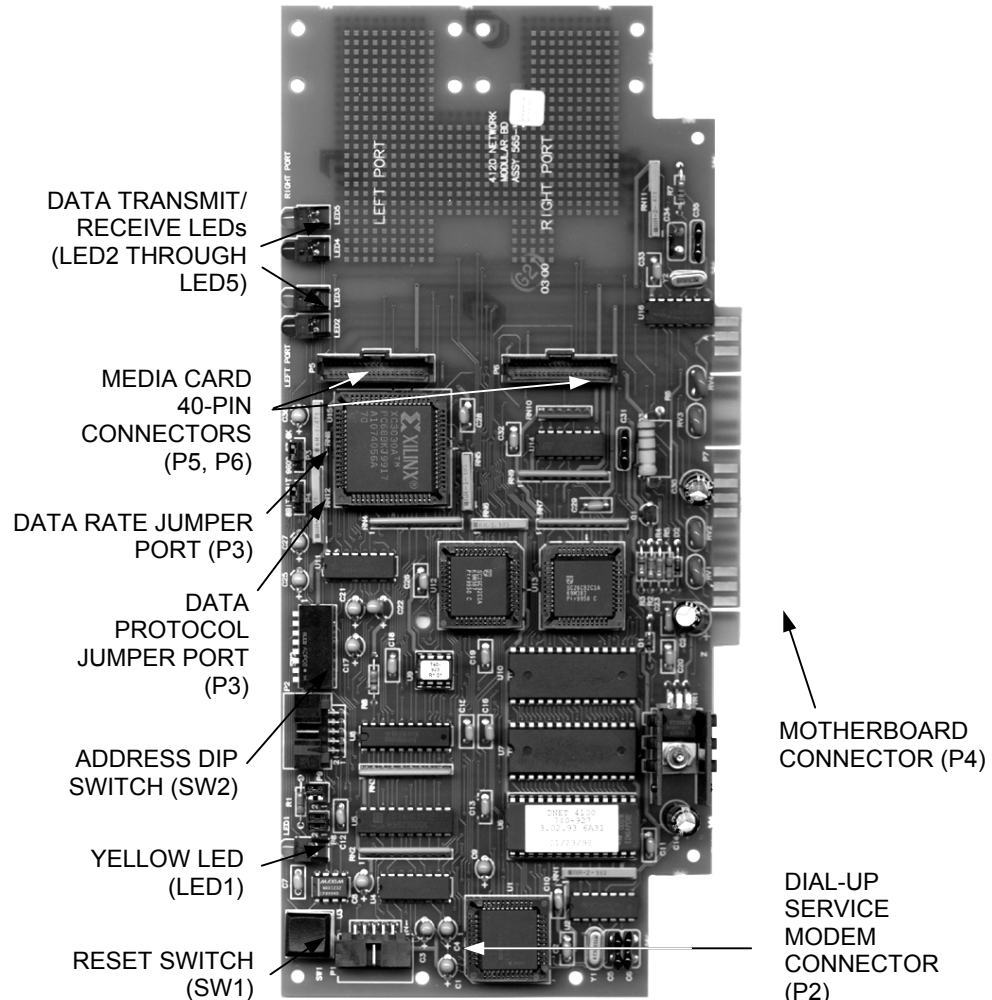

Figure 5-1. 4100-6014 Network Interface Card

NIC Card LED Indications

The 4100-6014 NIC has the following LEDs:

LED1 (yellow). Illuminates when

- The host 4100 requests it to illuminate
- A transmission fails
- It is off-line with the 4100 host
- It needs to be configured

LED2 (red). Illuminates when a data '0' is received at the right port.

LED3 (green). Illuminates when a data '0' is transmitted at the right port.

LED4 (red). Illuminates when a data '0' is received at the left port.

LED5 (green). Illuminates when a data '0' is transmitted at the left port.

Continued on next page

Introduction to the 4100 Network Interface Card (NIC), *Continued*

NIC Motherboards

The figures below are illustrations of two motherboards apart from the default CPU motherboard that can be used with the 4100 NIC.

- The 565-274 Master Motherboard holds two daughter cards: the 4100 master controller card and the 4100 NIC.
- The 565-275 Class B Motherboard holds the 4100 NIC by itself.

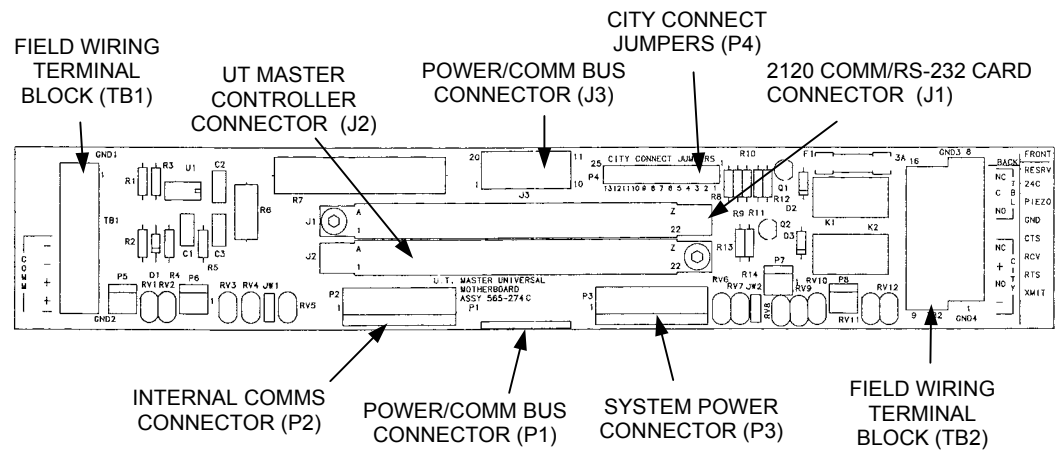

Figure 5-2. UT Motherboard with City Connection (565-274)

Note: The City (Brigade) connection is not used in Australia.

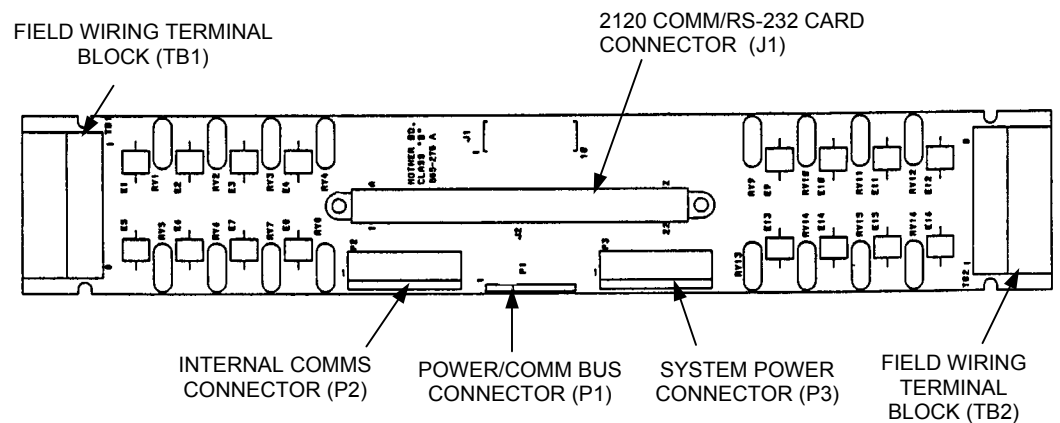

Figure 5-3. UT Motherboard without City Connection (565-275)

Continued on next page

Introduction to the 4100 Network Interface Card (NIC), *Continued*

NIC Media Cards

There are two approved modules that can be plugged into the 4100-6014 NIC:

- 4100-6057 Fiber-Optic Media Card (565-261)
- 4100-6056 Wired Media Card (565-413)

Each module is shown below.

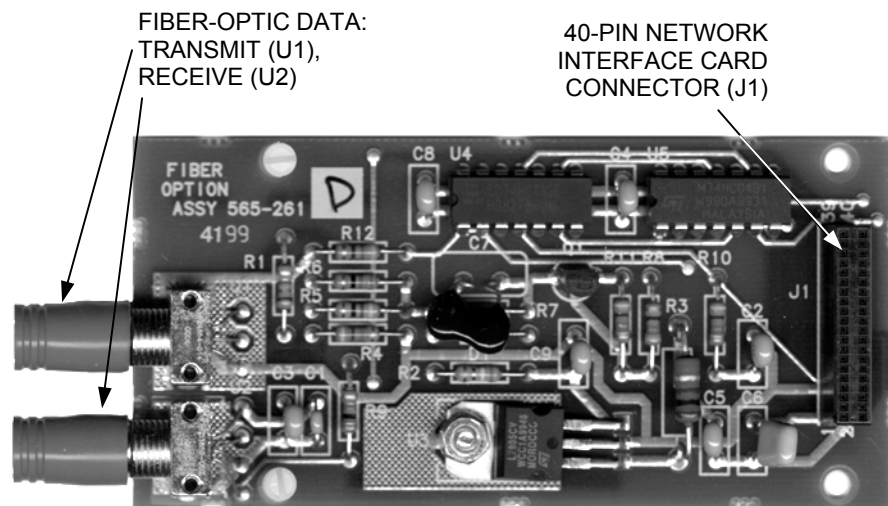

Figure 5-4. The 4100/4120-0143 Fiber-Optic Media Card

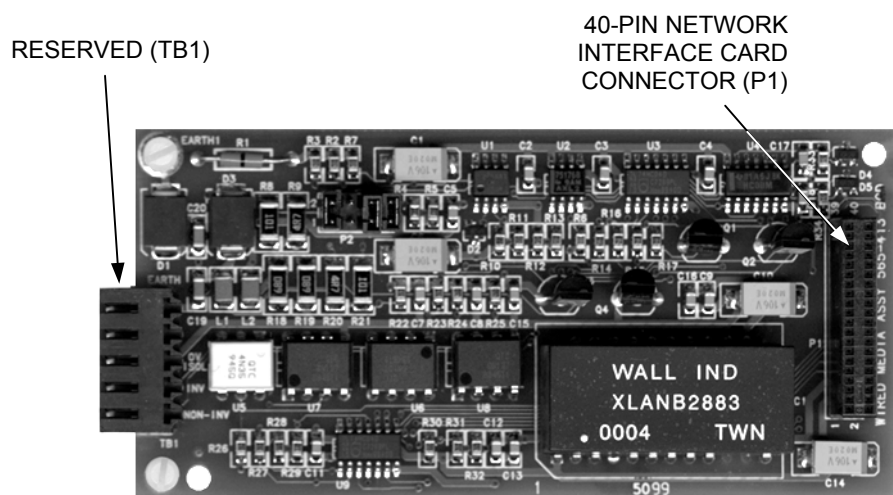

Figure 5-5. The 4100/4120-0142 Wired Media Card

Continued on next page

Introduction to the 4100 Network Interface Card (NIC), *Continued*

Requirements and Limitations

Table 5-1. 4100 NIC & Media Cards - Electrical and Environmental Specifications

Electrical Specifications	
Network Interface Card	Startup, no media cards: 8 VDC @ 110 mA Nominal, no media cards: 20 to 32 VDC @ 0 mA
Fiber Media Card	Using 24 V power supply: 20 VDC @ 140 mA max. Using 5 V power supply (GCC/NPU): 5 VDC @ 130 mA max.
Wired Media Card	4.75 to 5.25 VDC @ 170 mA max.
Environmental Specifications (All Modules)	
Operating Temperature	32° to 120° F (0° to 50° C)
Humidity	10% to 93% relative humidity at 90° F (32° C)

Step 1. Configuring Network Cards

Overview

The NIC card, along with the each media card, all have jumpers that must be set as shown below.

Motherboard Jumper Settings

NIC-compatible jumper settings on CPU motherboards depend on which motherboards are used.

Motherboard 565-274:

- JW1 and JW2 must be installed.
- Jumper plugs P5-P8 must not be installed.

Motherboard 566-227:

P10: Port 1 settings.

P11: Port 2 settings.

- P10/P11 position 1 – 2: Network card (NIC) attached to CPU motherboard (default).
- P10/P11 position 2 – 3: RS-232/2120 card attached to CPU motherboard.

NIC Card Address Setting

Use **SW2** to set the NIC card address. Refer to Appendix A for the address table.

Continued on next page

Step 1. Configuring Network Cards, *Continued*

NIC Card Jumper Settings

There are two shunt jumper ports on the NIC card that need to be set: P3 and P4.

P3: Determines the NIC data transmission rate, 57.6 kbits/second or 9600 bits/second.

- Position 1 – 2 (the right two pins) *or* no pins jumpered: 57.6 kbits/second.
- Position 2 – 3 (the left two pins): 9600 bits/second.

P4: Determines the data protocol, 8-bit or 9-bit, that the NIC card is using.

- Position 1 – 2 (the right two pins) *or* no pins jumpered: 9-bit.
- Position 2 – 3 (the left two pins): 8-bit.

All settings are labeled on the card.

Wired Media Card Jumper Settings

P2: Tells the system which wire type is to be used.

- Positions 1 – 2, 5 – 6, and 7 – 8: 18 AWG shielded, twisted pair wiring.
- Remove all jumpers to specify 24 AWG twisted pair telephone cable wiring.

IMPORTANT: When using the wired media card, the Earth fault detection is performed on the left port only. Remove R1 (1 Ohm resistor) from the media card on the right port.

Step 2. Mounting Media Cards to the NIC

Overview

The 4100-6014 Network Interface Card (NIC) uses media cards to connect to other NICs. This section describes how the media cards are mounted onto NICs.

Media Card Mounting

NICs connect to each other via the three types of media cards. The types of media cards in the right and left ports are determined by the type of wiring that is being used across cards.

Connect P1 on the wired media card, *or* J1 on the modem or fiber media cards, to P5 (the left port) on the NIC.

To connect a second media card to the same NIC, connect it as described above, but use P6 (the right port) on the NIC. Note that any two types of media cards can be connected to the same NIC.

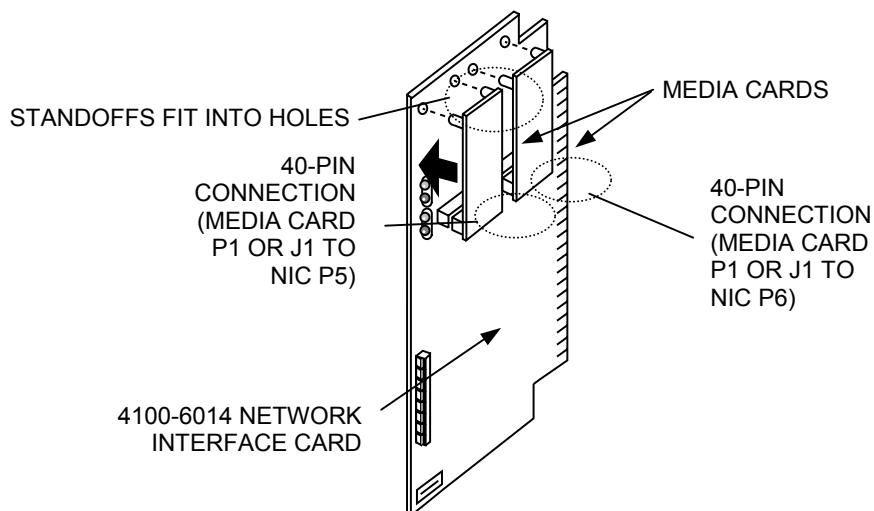

Figure 5-6. Media Card Mounting

Step 3. Mounting Network Cards

The 4100 NIC daughter card, shown in Figure 6-8 below, inserts into motherboards as follows:

- If the 565-274 Master Motherboard is being used, the NIC daughter card is inserted into connector J1.
- If the 566-227 Master Motherboard or 565-275 Motherboard is used, the NIC daughter card is inserted into connector J2.

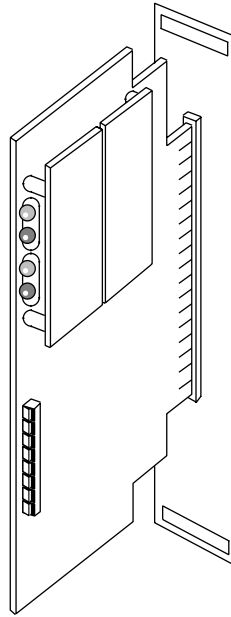

Figure 5-7. Installing the Daughter Card

Step 4. Wiring Network Cards

Overview

The nodes in the network now have to be wired together, so that the NIC in one host panel connects to the NIC in the next panel. This section contains guidelines and instructions for NIC wiring.

Wiring Guidelines

Refer to the following guidelines whenever field wiring the NICs.

- Network nodes must be wired right to left port, regardless of the media type selected.
- Style 7 protection is achieved by wiring the nodes in a loop fashion. A single fault (except an Earth fault) will cause the network to reconfigure for degraded Style 7 (Style 4) operation. A second fault (except an Earth fault) will result in the network dividing into two separate networks.
- Style 4 is achieved by wiring the nodes in a linear fashion. Style 4 networks are not fault-tolerant and a single fault (except an Earth fault) will result in the network dividing into two separate networks.
- Earth fault detection is performed on the left port only. When a network Earth fault occurs, the trouble is only reported on the node whose left port is connected to the span.
- All 18 AWG (0.8231 mm²) wiring used with 4100-6056 Wired Media Cards must be twisted-shielded pair. All 24 AWG (0.2047 mm²) (telephone cable) used with 4100-6056 must be twisted pair. When shielded cable is used, the shield must be terminated to chassis Earth on the left port only.
- It is permissible to use mixed media in a network. For example, some spans may be “wired media” while others are optical fiber or telephone modem.
- Each NIC has a jumper for selecting between network data rates of 57.6 kbps and 9.6 kbps. All cards in the network must be set for the same rate. (When modem media or physical bridging is used, the data rate must be set for 9.6 kbps).
- Each NIC has a jumper for selecting between 8- and 9-bit network protocols. All cards in the network must be set for the same network protocol. (When modem media or physical bridging is used, the protocol must be set for 8-bit).
- All network wiring except the shield is supervised and power limited.
- When wiring leaves the building, 2081-9044 Overvoltage Protectors are required. One overvoltage protector is installed where wiring leaves the building; another is installed where wiring enters the next building.

Continued on next page

Step 4. Wiring Network Cards, *Continued*

- 655-158 Transient Suppressor (ordered as part of 748-599) is required for each modem-to-telephone line connection.

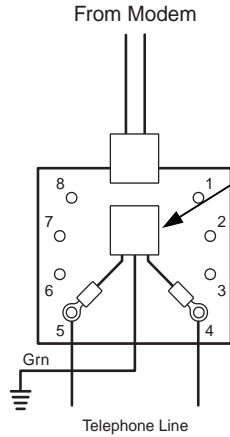

Figure 5-8. The Transient Suppressor

Wiring Distances

Maximum wiring distances are shown in the Table below and in Appendix J.

Table 5-2. Wiring Distances

Media Type	Size	Data Rate	Max Distance
Wired	24 AWG (0.2047 mm ²)	57.6 kbps	7,000 ft (2,134 m)
		9.6 kbps	12,000 ft (3,658 m)
	18 AWG (0.8231 mm ²)	57.6 kbps	10,000 ft (3,048 m)
		9.6 kbps	17,000 ft (5,182 m)
Optical Fiber	50/125 um	57.6 or 9.6 kbps	10,000 ft (3,048 m)
	62.5/125 um	57.6 or 9.6 kbps	15,000 ft (4,572 m)
RS-232	18 AWG (0.8231 mm ²)	57.6 kbps	50 ft (15 m)
		9.6 kbps	300 ft (91 m)

Notes:

- The characteristics for 0.75 mm² are shown in Appendix J.
- 18 AWG (0.8231 mm²) fire-rated twisted, shielded pair must not exceed 58 pF per foot and be less than or equal to 6.385 Ohms per 1,000 feet (305 m).
- 24 AWG (0.2047 mm²) twisted, unshielded telephone cable must not exceed 22 pF per foot and be less than or equal to 25.6 Ohms per 1,000 feet (305 m).

Related Documentation

Refer to the 900-242 Field Wiring Specifications or 900-143 Fiber Tutorial for additional NIC wiring information.

Continued on next page

Step 4. Wiring Network Cards, *Continued*

Fiber-Optic Wiring

Connectors U1 (transmitter) and U2 (receiver) on the 4100-6057 Fiber-Optic Media Card are used to connect 4100-6014 NICs across parts of a network.

Note: ST connectors with long strain relief boots are to be used with the fiber optic cable.

Figure 6-10 shows how two network nodes are connected via fiber-optic cable.

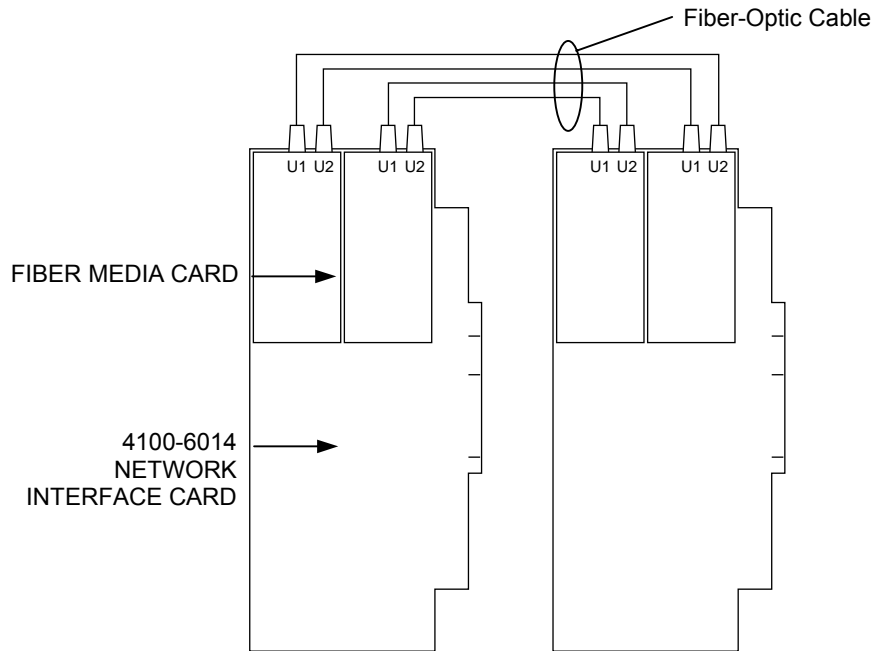

Figure 5-9. Fiber Wiring

Fiber Optic Connection Types

Dual Fiber Optic Cable Connections. The standard fiber optic connection between network nodes uses two fiber optic cables, one for transmit, and the other for receive. This connection allows for optimum communications distance.

The available communications distance is determined by the properties of the specific fiber cable used. Distances can be determined using the information and examples shown below in Table 6-3.

Single Fiber Optic Cable Connections. For applications where a single fiber cable is available, or where use of a single cable is desired, using a model 4190-9010 Bi-Directional Coupler at each node combines the separate transmit and receive signals into a single path (refer to the requirements list).

This connection allows use of a single fiber cable, but it does reduce communications distance as indicated in the information and examples shown below in Table 6-4.

Continued on next page

Step 4. Wiring Network Cards, *Continued*

4190-9010 Coupler Requirements

The 4190-9010 Coupler (271-012) is used with the 565-261 Fiber Optic Media Board, revision "C" or higher. Two 4190-9010 Bi-Directional Couplers are required per connection, one at each node.

The 4190-9010 is equipped with type ST connectors. To make type ST to type ST connections, an ST to ST coupler, by others, is required. ST to ST Couplers are available from:

Black Box, part # FO200
 Fiber Instrument Sales, part # F1-8101
 Newark Electronics, part # 95F2097
 (or equivalent)

Table 5-3. Dual Fiber Optic Cable Communications Distance Examples

Fiber Type ^{1*}	MIFL ²	Power Margin	Distance ³	Budget ³
50/125 numerical aperture = 0.2	4 dB/km	4 dB	10,000 ft (3.05 km)	17 dB
	3 dB/km	3 dB	15,000 ft (4.57 km)	
62.5/125 numerical aperture = 0.275	4 dB/km	4 dB	13,000 ft (3.96 km)	21.4 dB
	3.75 dB/km	3 dB	15,000 ft (4.57 km)	

*See notes at bottom of page.

Table 5-4. Single Fiber Optic Cable Communications Distance Examples Using 4190-9010 Bi-Directional Couplers

Fiber Type ¹	MIFL ²	Power Margin	Distance ³	Budget ³	4190-9010 Coupler Loss	ST to ST Coupler Loss
50/125 numerical aperture = 0.2	3 dB/km	2 dB	7,650 ft (2.33 km)	21.4 dB	9.4 dB	3 dB
62.5/125 numerical aperture = 0.275	3.2 dB/km		8,200 ft (2.5 km)			2 dB

Notes for Tables Above:

1. Cable specifications are for 50 or 62.5 micron core with 125 micron cladding, multi-mode graded index fiber. Wavelength = 850 nm.
2. MIFL = Maximum Individual Fiber Loss. Numbers shown are for example reference only, refer to specific cable for exact specification.
3. Maximum cable length is determined by distance listed or by reaching budget value, whichever is shorter. Maximum distances listed for dual fiber cable are shorter than would be calculated. Budget using 4190-9010 Bi-Directional Coupler is the same with either size cable because the coupler input cables are 62.5/125 fiber allowing launch power to be the same.

Continued on next page

Step 4. Wiring Network Cards, *Continued*

4190-9010 Coupler Requirements (continued)

The illustration below shows coupler wiring.

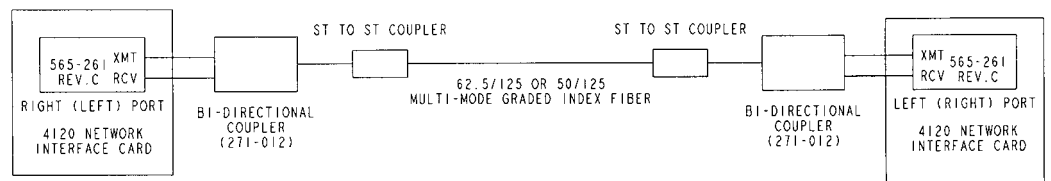

Figure 5-10. Coupler Wiring

Wiring with the Wired Media Card

Refer to the guidelines and figures in this topic to use wired media cards.

IMPORTANT: TB1 on the wired media card must not be used when it is connected to the 4100-6014 NIC.

- When the 565-413 Interface Card is used with 565-516, -407, or -409 Network Card, TB1 on the 565-413 Interface Card **cannot** be used. Connection to the motherboard is required as shown.
- The shield should only be connected at one end of the line. The shield is connected to the left port.
- When wiring leaves the building, 2081-9044 Overvoltage Protectors are required. One overvoltage protector is installed where wiring leaves the building; another is installed where wiring enters the next building.

Continued on next page

Step 4. Wiring Network Cards, *Continued*

Wiring with the Wired Media Card (continued)

The Table below lists the 4100U master motherboard connections for the wired media card.

Table 5-5. 566-227 CPU Motherboard Wired Media Connections

Motherboard Port for Media Card Connected to P5	Wired Media Card Connection (Left Port)
TB1-4	0 V
TB1-5	Earth ground
TB1-6	INV (-)
TB1-7	None
TB1-8	NONINV (+)
Motherboard Port for Media Card Connected to P6	Wired Media Card Connection (Right Port)
TB3-1	NONINV (+)
TB3-2	Reserved
TB3-3	INV (-)
TB3-4	Earth ground
TB3-5	0 V

Figure 5-11, below, shows how two CPU motherboards with wired media network cards connect to each other in the 4100U.

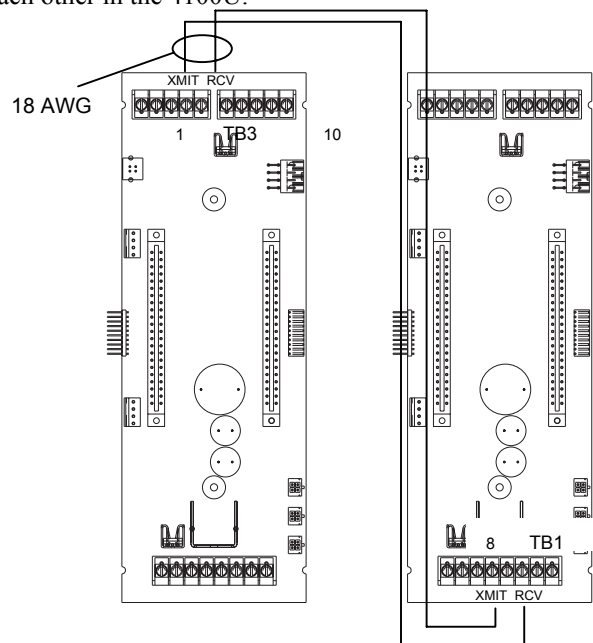

Figure 5-11. Wired Media Interconnections Between 4100U Motherboards

Continued on next page

Step 4. Wiring Network Cards, *Continued*

Wiring Illustrations

The figures below show how to wire the NIC. The illustrations use the 565-274 and 565-275 motherboards only. If you are using the 4100U motherboard, refer to Figure 5-11 along with the figures below.

Wired Media, Style 7 Wiring

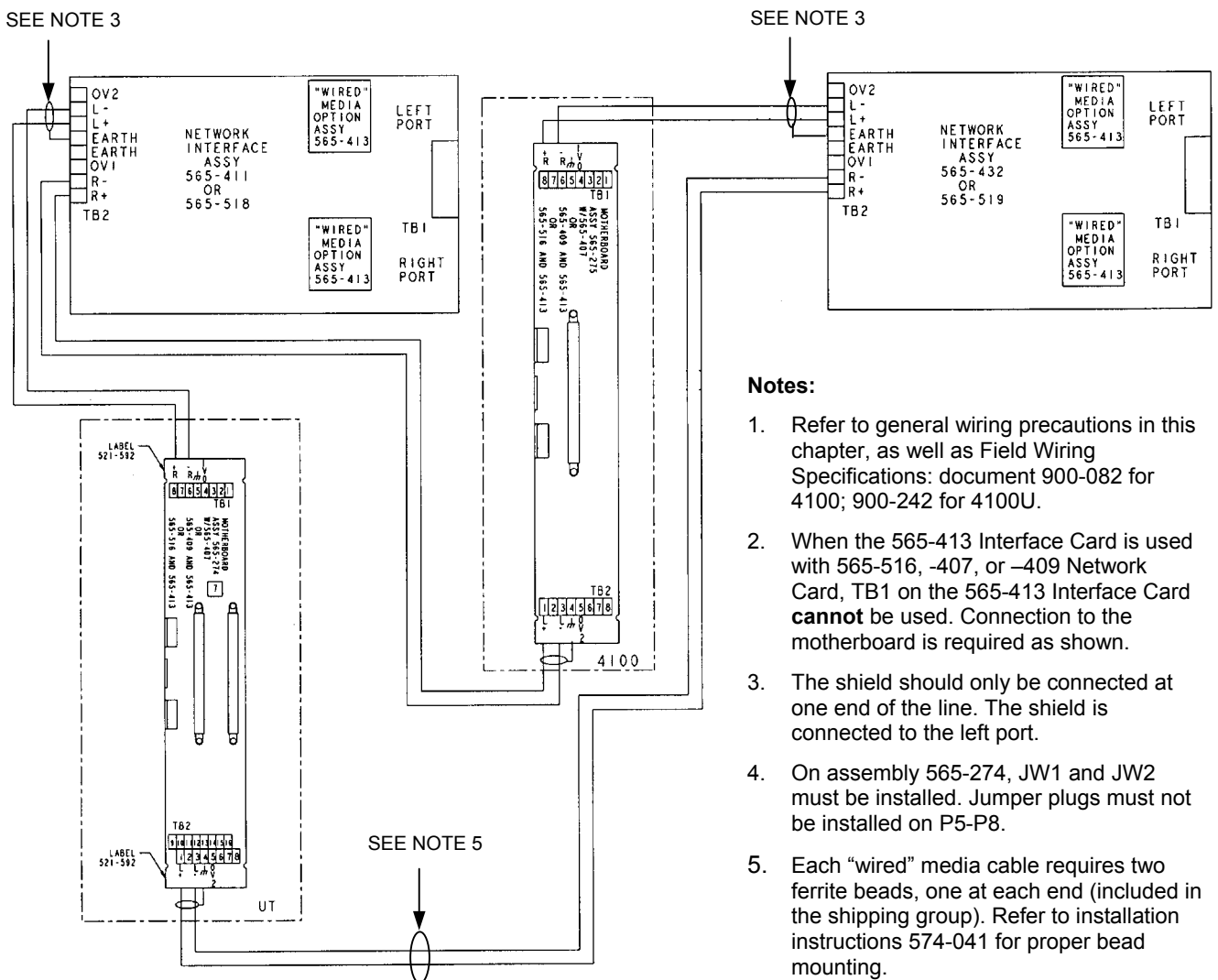
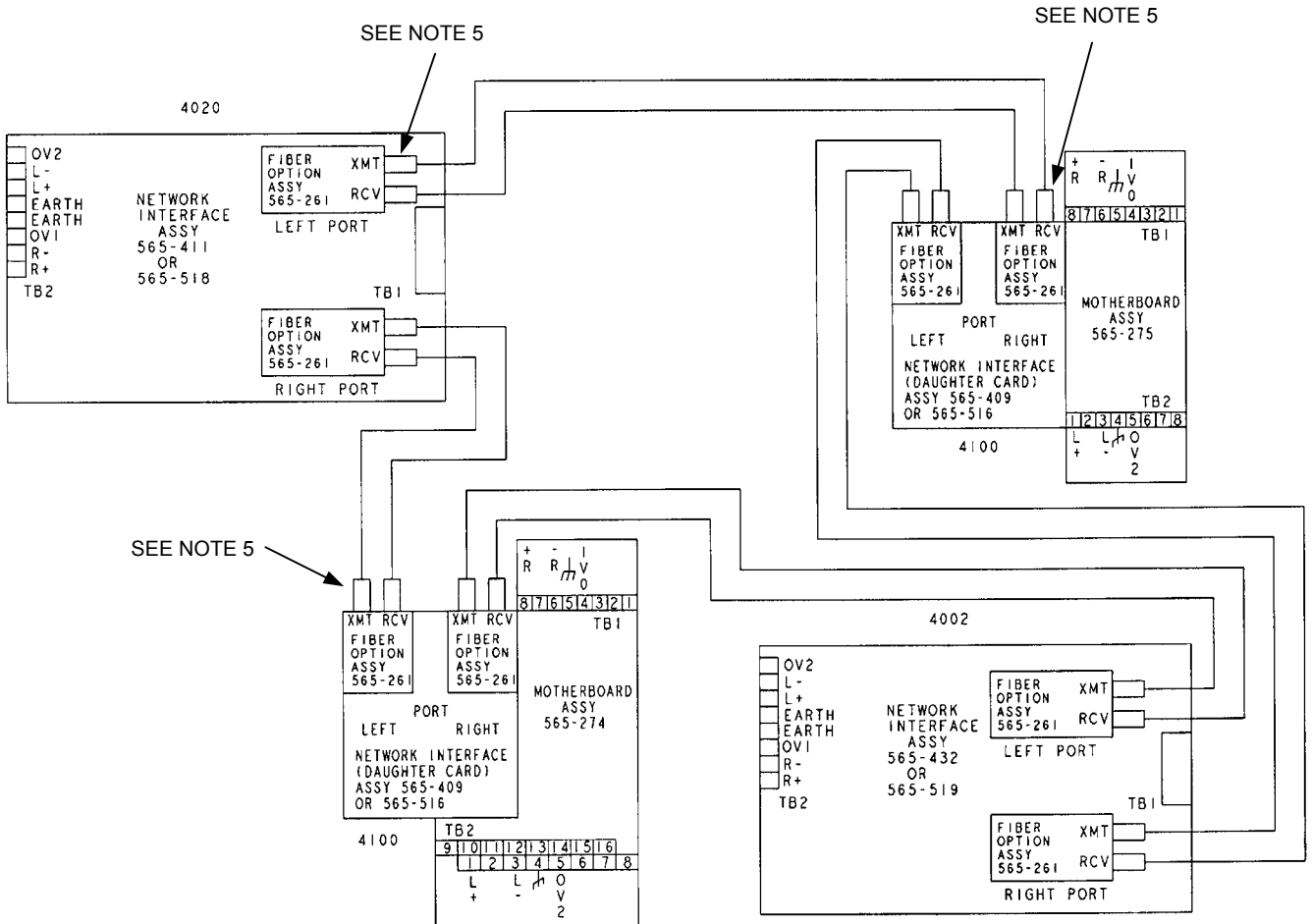

Figure 5-12. Wired Media, Style 7 Wiring

Continued on next page

Step 4. Wiring Network Cards, *Continued*

Fiber Optic, Style 7 Wiring



Notes:

1. Refer to general wiring precautions in this chapter, as well as Field Wiring Specifications: document 900-082 for 4100; 900-242 for 4100U. For specific information about fiber optic wiring, refer to the 900-143 Fiber Tutorial.
2. The maximum distance between nodes when using the fiber communication path is dependent upon the fiber's multimode graded index: 10,000 feet (3,048 m) for 50/125 fiber; 15,000 feet (4,572 m) for 62.5/125 fiber. The maximum cable O.D. is 0.118 (3 mm). Reference document 900-143 for other fiber sizes.
3. ST connectors with long strain relief boots are to be used with the fiber optic cable.
4. On assembly 565-274, JW1 and JW2 must be installed. Jumper plugs must not be installed on P5-P8.
5. Cable clamps supplied with 748-531 are used to secure the fiber cable.

Figure 5-13. Fiber Optic, Style 7 Wiring

Continued on next page

Step 4. Wiring Network Cards , Continued

Wired Media and Fiber Optic, Style 7 Wiring

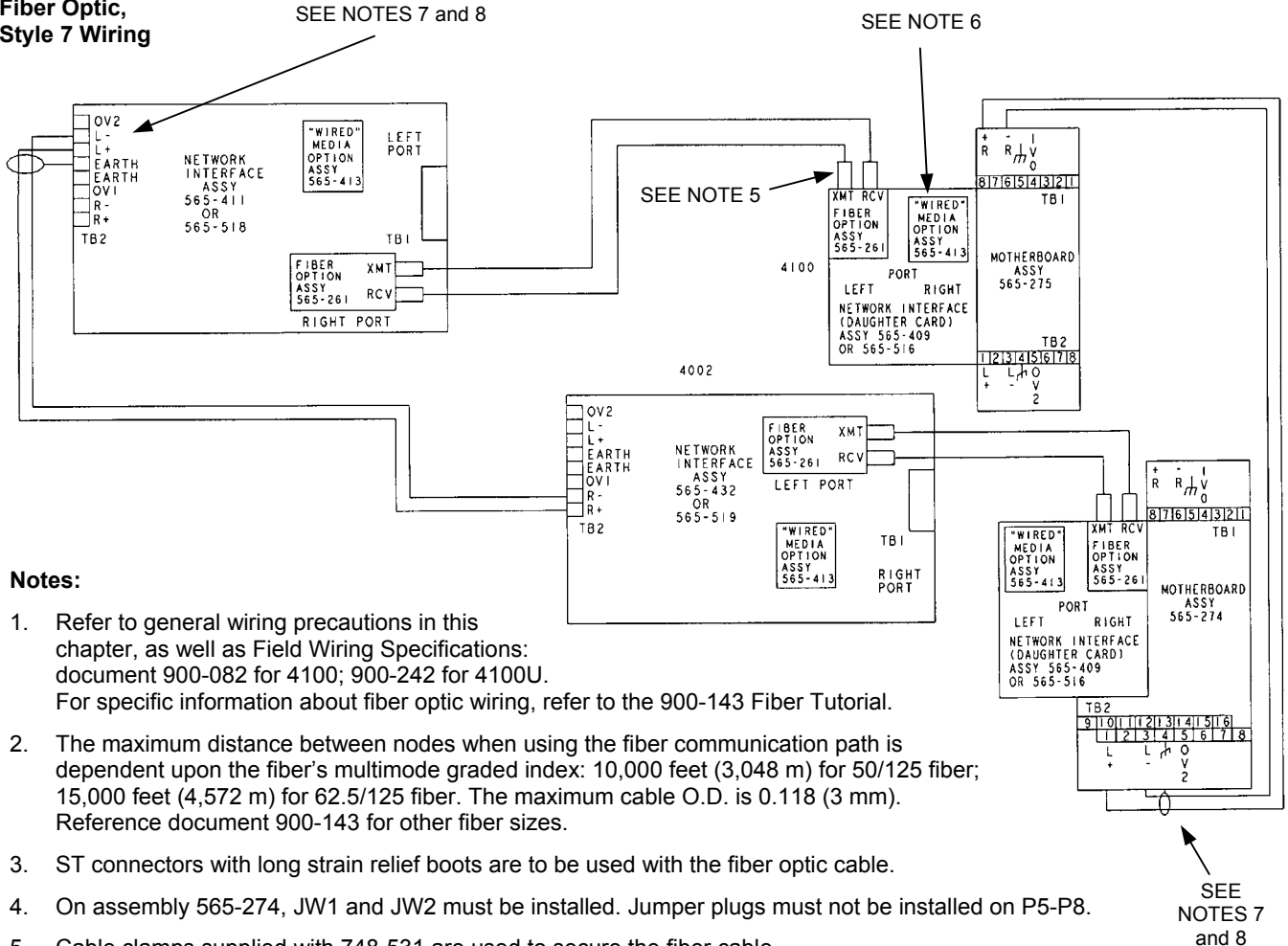

Notes:

1. Refer to general wiring precautions in this chapter, as well as Field Wiring Specifications: document 900-082 for 4100; 900-242 for 4100U. For specific information about fiber optic wiring, refer to the 900-143 Fiber Tutorial.
2. The maximum distance between nodes when using the fiber communication path is dependent upon the fiber's multimode graded index: 10,000 feet (3,048 m) for 50/125 fiber; 15,000 feet (4,572 m) for 62.5/125 fiber. The maximum cable O.D. is 0.118 (3 mm). Reference document 900-143 for other fiber sizes.
3. ST connectors with long strain relief boots are to be used with the fiber optic cable.
4. On assembly 565-274, JW1 and JW2 must be installed. Jumper plugs must not be installed on P5-P8.
5. Cable clamps supplied with 748-531 are used to secure the fiber cable.
6. When the 565-413 Interface Card is used with 565-516, -407, or -409 Network Card, TB1 on the 565-413 Interface Card **cannot** be used. Connection to the motherboard is required as shown.
7. The shield should only be connected at one end of the line. The shield is connected to the left port.
8. Each "wired" media cable requires two ferrite beads, one at each end (included in the shipping group). Refer to installation instructions 574-041 for proper bead mounting.
9. When wiring leaves the building, 2081-9044 Overvoltage Protectors are required. One overvoltage protector is installed where wiring leaves the building; another is installed where wiring enters the next building.

Figure 5-14. Wired Media and Fiber Optic, Style 7 Wiring

Chapter 6

The System Power Supply & Alarm Relay Card

Introduction

The SPS is described in Chapter 2. A picture is shown in Figure 2.4.

This chapter has the current and voltage ratings of the system power supply (SPS) and describes how it is installed and configured by the factory. It also describes the Alarm Relay Card that mounts onto the SPS to provide 3 extra relays.

In this Chapter

Refer to the page number listed in this table for information on a specific topic.

Topic	See Page #
SPS Specifications	6-2
SPS Configuration	6-4
SPS LED Indications	6-5
Troubleshooting on SPS	6-6
The Alarm Relay Card	6-7

SPS Specifications

Input/Output/Battery Specifications

The following table summarizes the specifications for the SPS.

Table 6-1. SPS Input and Output Specifications

AC Input Specifications	
SPS in Standard Australian FACP 4100-9848AU	2 A Maximum 240 VAC + 6% -10% @ 50 Hz
DC Output Specifications	
Voltage	Nominal 28VDC Minimum: 19.5 VDC Maximum: 32 VDC Ripple: 2 VDC p-p @ full load (9A)
Total Current (max)	9A alarm load. Includes: NACs (+24V Sig); +24V Card; +24V Aux; SPS card power including on-board IDNet. 5A non-alarm load. Includes as per above, allows for battery charging at high rate.
24V Card 24V Aux	2A max. See note. 2A max
Each NAC (total A+B)	3A max alarm load 2A max non-alarm load (used as Aux 24V power).
SPS IDNet Output	30 V or 35 V (see note below)
Battery Charger Specifications	
Input Voltage Range	21-33 VDC
Output Float Voltage	27.3 VDC \pm 200 mV @ 20°C, temperature compensated at approximately -36mV/°C (0° C to 50° C)
Output Current Limit	1.4 A (For 6.2 – 18 Ah battery) 3.3 A (Default; for 18-110 Ah battery)

Notes:

- AC power must be provided to the 4100U from a dedicated AC branch circuit. The AC input is supervised.
- 240 VAC: The service branch circuit breaker should be sized to handle at least 150 percent of the total required by all of the power supplies in the system.
- The bulk supply (rated at 9A max) which feeds 24V Sig, 24V Card, 24V Aux also supplies the SPS Card including the on board IDNet, and the battery charger. The charger is disabled during alarms so as to make the 9A available on the other busses. (See the following table for the SPS current.)

Continued on next page

SPS Specifications, *Continued*

- +24V Sig is used to supply the NACs. It can be made accessible by configuring a NAC as an aux power output (normally energized). The PDI has a 24V Sig bus that is only powered when an SPS is plugged directly on to it. (Not in standard configuration). The 4100 MXP is the only Australian approved card that takes power from this bus. All other cards draw power from +24V Card.
- The battery circuit is supervised every 29 seconds. The battery test (custom control) is for 1 hour once per week.
- The battery is connected to the charger but is normally disconnected from the bulk supply. During mains fail, and the 1 hour battery test, the battery gets connected to the bulk supply.
- The IDNet output is 30V in the normal condition as is used to prolong battery standby. When it is necessary to activate large numbers of output devices on IDNet peripherals (such as piezo sounders), the output voltage is increased to 35V to provide sufficient voltage at the end of line to activate the piezo. The higher voltage state is an alarm condition for the purpose of standby battery calculation.

SPS Current Consumption

The following table summarizes battery standby capabilities for the SPS. Voltage assumed is 24 V, which is the rated battery voltage for lead-acid type batteries.

Table 6-2. SPS Current Specifications

Standby Conditions	Current
<ul style="list-style-type: none"> • No alarms (NACs normal) • IDNet LED ON, no IDNet devices connected 	175 mA
Add to above for each additional set of 50 IDNet devices in standby, with IDNet at 30 V	40 mA
Total current for fully loaded IDNet channel (250 devices) in standby	375 mA
Alarm Conditions	Current
<ul style="list-style-type: none"> • 3 NACs ON • IDNet LED ON, no IDNet devices connected 	185 mA
Add to above for each set of 50 IDNet devices in alarm, 20 LEDs ON	80 mA
Add to above for each set of 50 IDNet devices in alarm, LEDs OFF	50 mA
Total current for a fully loaded IDNet channel (250 devices) in alarm, 20 LEDs ON	475 mA

Notes:

- *Additional standby conditions:* Trouble relay activated, power trouble LED on, IDNet LED on, battery charger off, auxiliary power load = 0 mA
- *Additional alarm conditions:* Trouble relay activated, power trouble LED on, IDNet LED on, battery charger off, auxiliary power load = 0 mA, NAC alarm load = 0 mA, IDNet = 35 V

Continued on next page

SPS Specifications, *Continued*

Environmental Requirements

The range of possible temperatures under which the SPS may function are between 0° C and 50° C (120° F).

The SPS operates normally under non-condensing humidity conditions up to 93% with relative humidity at 32° C.

SPS Configuration

Overview

This section contains information about SPS jumpers, DIP switches and potentiometers.

Jumper Settings

P2: If the SPS IDNet outputs are being used, you may change P2 to configure the IDNet shield connection.

- Position 1 – 2 (bottom): Connects the shield to 0 V (default).
- Position 2 – 3 (top): Connects the shield to earth ground.

P3: City Card and Relay Card operation

- Position 1-2 (top): Install in pos. 1-2 only if a relay card 4100-6033 is installed and has relay 3 programmed for operation other than "Fault (Trouble)"
- Position 2-3 (bottom): (default) For use with 4100-6033 if relay 3 is programmed for "activate on fault (trouble)" operation. (This option is used for Brigade connection)

P1: Earth connect jumper.

- Position 1 – 2 (rhs): Enables Earth fault monitoring. Set to this position **unless** the system uses a TrueAlert Power Supply under common 0 V.
 - Position 2 – 3 (lhs): Disables Earth fault monitoring. Set to this position **only if** the system uses a TrueAlert Power Supply under common 0 V.
-

Setting the Device Address

Refer to Appendix A to set the device address for the SPS with DIP switch SW1.

Adjusting Voltages

There are two 4mm (i.e. small), potentiometers on the 4100-9848AU SPS, situated below the centre of the pcb. These are adjusted in the factory and typically, will not need adjusting in the field.

If it is required to adjust them, turning the potentiometer clockwise increases the voltage.

R341 Battery Charger Voltage

Adjust this potentiometer to achieve a charger voltage of $27.3V \pm 0.1V$ at 20°C. (Allow -36V/°C for temperatures different to 20°C).

R342 Voltage Measurement Calibration

Adjust this potentiometer to match the measurement of charger voltage on the panel LCD with that on a calibrated voltmeter measuring the charger output. Use the "Card Status" option of the menu. Match the two readings to within 0.05Vdc.

SPS LED Indications

LEDs

The SPS has the following LEDs:

LED1 (yellow). Illuminates when NAC 1 is ON or in Fault.

LED2 (yellow). Illuminates when NAC 2 is ON or in Fault.

LED3 (yellow). Illuminates when NAC 3 is ON or in Fault.

LED4 (yellow). Illuminates to indicate a communications loss with the system CPU; normally off. If this LED is blinking, try re-loading the software to FLASH.

LED5 (yellow). Indicates IDNet status.

- Slow blink: Class A open circuit Fault.
- Fast blink: Short circuit Fault.
- On steady: No devices detected/ channel failure.
- Normally off.

LED6 (yellow). Indicates power supply status.

- Single blink: Positive earth fault.
- Double blink: Negative earth fault.
- Triple blink: Battery Fault.
- Quadruple blink: Charger Fault.
- On steady: Overcurrent fault.
- Normally off.

LED7 (green). Illuminates when the power supply is powered from the AC line. Off when the power supply is de-energized, or when it is using battery backup power.

Troubleshooting on SPS

Overview

This section contains explanations of fault messages that may appear on the 4100U display when using the SPS. Heading text in the left margin shows the error message, while the paragraph next to it describes the likely cause of the message.

IDNet Power Monitor Trouble

There is no output voltage from the power supply. Refer to Chapters 2 and 6 for information on power supplies.

Extra Device

Appears if one or more extra devices (i.e., devices that have not been configured for the IDNet channel) are on the system. Only one message appears, regardless of the number of extra devices found.

Class A Trouble

There is an open on the IDNet channel. A hardware reset is required to reset the fault.

Earth Fault Search

Comes up during the Earth Fault Search diagnostic function. Once the search is initiated, the front panel display indicates how far along the search process has progressed (10%, 25%... 75%), and then shows the results of the search. The result either identifies the offending circuit or indicates that the earth fault could not be found. SPS circuits (IDNet, NAC, and aux power) are searched. System alarm and trouble processing is suspended during the search.

Short Circuit

Appears when a short is detected on the IDNet channel. This status clears automatically when the short circuit is removed.

Channel Fail

Appears when each device on the IDNet channel has been configured, and when none of the devices are communicating on the channel. This message does not appear if there are no configured devices on the IDNet channel.

No Answer/ Bad Answer

Occurs when the 4100 is put into a diagnostic mode and finds a device not responding, or responding unreliably. Refer to the *4100U PC Programmer Programming Manual* (574-849) for information on how to perform this diagnostic.

Output Abnormal

Occurs when 24 V is not present on TrueAlarm devices or when TrueAlarm sensor bases with relay driver outputs are not properly supervised or when isolator devices are in isolation mode.

The Alarm Relay Card

Overview

The Alarm Relay Card mounts on, and is driven by, the SPS. It has 3 relays each providing one set of voltage-free contacts.

The relays are able to be configured under custom control, but the default operation is for system status, i.e. Fault (Trouble), Isolate (Supervisory), and Alarm, respectively. These are commonly used to drive the Brigade signalling.

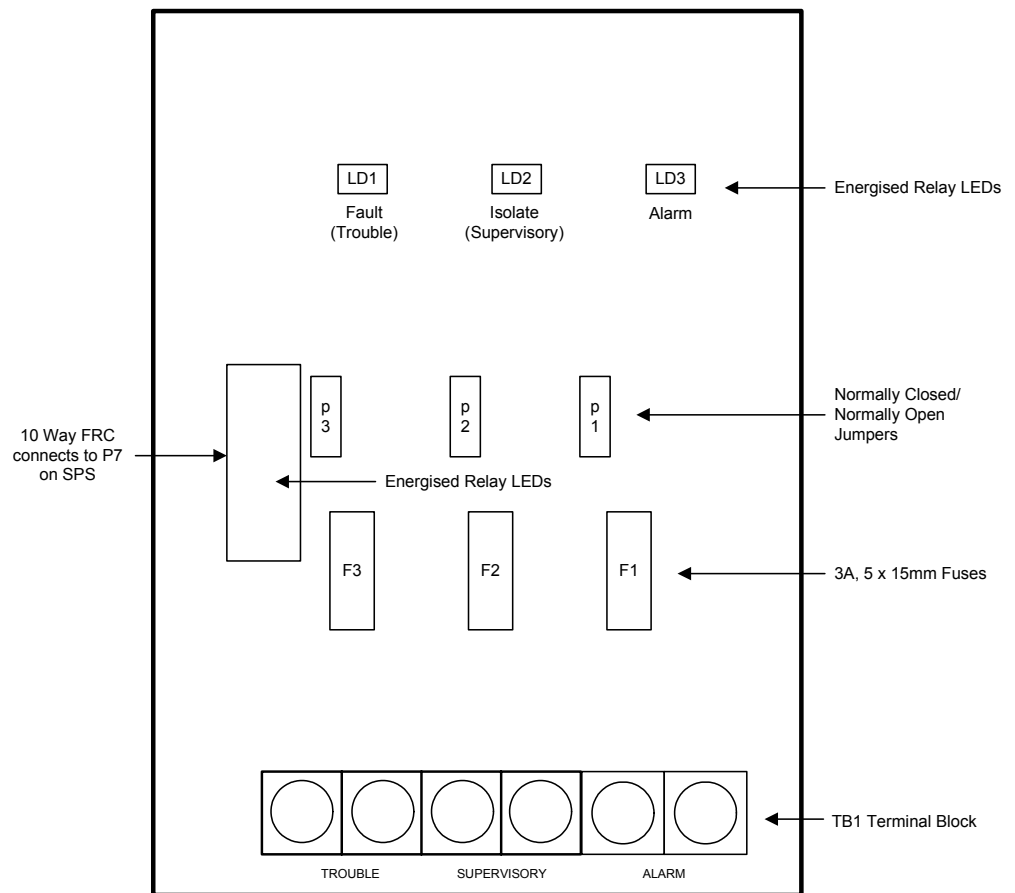

Figure 6-1. The Alarm Relay Card

Mounting

The Alarm Relay Card mounts on the SPS adjacent to the largest relay K3. With the power disconnected, fit the card using the 3 plastic stand-offs and one Torx screw with plastic sleeve.

Connect P4 on the relay card to P7 on the SPS with the 10 way FRC provided.

The Alarm Relay Card, *Continued*

Configuration

The relays have one set of voltage-free contacts (see note below) connected to one pair of terminals via a header. The two terminals are configured for normally closed or normally open by positioning a jumper on the header.

Table 6-3. Alarm Relay Card Jumper Positions

Relay	Header	Normally Closed	Normally Open
Alarm	P1	1-2 (top)	2-3 (bottom)
Isolate (Supervisory)	P2	1-2 (top)	2-3 (bottom)
Fault (Trouble)	P3	1-2 (top)	2-3 (bottom)

Notes

- The common contact of each relay has a transient suppressor to earth, and must not be used to switch voltages greater than its rating.
- The common contact is protected with a 3A fuse.
- For default configuration the relays are normally de-energised and energise on Fault/Isolate/Alarm.
- The corresponding LED illuminates when the relay is energized.
- The relays may be configured under custom control to operate other than default.

Warning

If relay RL3 is configured for operation other than Fault (Trouble), jumper P3 on the SPS must be shifted to positions 1-2 (top).

Specification

CARD	
Input Voltage	20-32Vdc
Input Current	15mA @ 24V, quiescent
(nominal)	37mA @ 24V, all relays on
RELAYS	
Form	Voltage-free changeover, suppresses to earth
Voltage	30Vac, 32Vdc
Current	2A, resistive load
FUSE	
F1, F2, F3	5 x 15mm, Glass Cartridge, 3A (208-163)

Chapter 7

SPS Field Wiring (4100U)

Introduction

This chapter shows how various devices are wired to an SPS. It includes connection to NACs, IDNet, relays, and power circuits.

In this Chapter

Refer to the page number listed in this table for information on a specific topic.

Topic	See Page #
General Field Wiring Guidelines	7-2
SPS NAC Field Wiring Guidelines	7-3
Power Supply Wiring Distances	7-5
SPS Auxiliary Power Wiring	7-8
SPS Relay Wiring	7-10
SPS IDNet Wiring	7-12

General Field Wiring Guidelines

General Guidelines

Make sure these guidelines are accounted for before wiring:

- All field wires must be 0.75 mm² or greater and comply with AS1670.1 and the wiring code.
- Conductors must test free of all grounds.
- All wiring must be done using copper conductors only, unless noted otherwise.
- If shielded wire is used,
 - the metallic continuity of the shield must be maintained throughout the entire cable length.
 - the entire length of the cable must have a resistance greater than 1 Megohm to earth ground.
- Underground wiring must be free of all water.
- In areas of high lightning activity, or in areas that have large power surges, the 2081-9027 Transient Suppressor should be used on monitor points.
- Wires that run in plenum should be in conduit.
- A system ground must be provided for earth detection and lightning protection devices. This connection must comply with approved earth detection.
- Only system wiring should be run together in the same conduit.
- Use supplied ferrite beads with all SPS field wiring including the Aux 24V. Loop wires twice through the supplied ferrite bead(s) as shown in Figure 7-1. (Extra can be ordered as SX0005.)

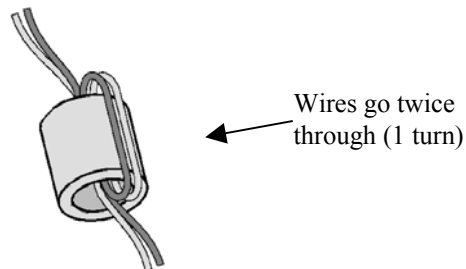

Figure 7-1. The Ferrite Bead (SX0005)

Continued on next page

SPS NAC Field Wiring Guidelines

Overview

Each of the 3 NACs has two pairs of driven outputs (A+/A-, B+/B-) which operate together.

NAC B outputs have polarity reversal supervision and expect a 10k EOLR. Each connected device must have a suitably rated blocking diode.

NAC A outputs have an integral 10k to accommodate Class A (loop) wiring. Class A wiring is not mandatory under AS1670.1.

The 3A max rating applies to each NAC, B + A outputs combined. NAC load current may be read on the LCD.

The Australian SPS has extra decoupling capacitors fitted to the NAC outputs, and cannot be used to drive the Simplex range of addressable appliances.

NACs may be programmed to be normally on and the terminals used as power supply outputs. See the SPS Auxiliary Power Wiring section following.

Guidelines

Review the following guidelines for NACs before you begin NAC field wiring.

- All wiring shall be 0.75 mm² to 4 mm².
 - All wiring is supervised and power-limited.
 - The maximum alarm current is 3 A per circuit. The supervisory current is 2.03 mA at 24 VDC.
 - The nominal voltage rating is 24 VDC, 2 V p-p ripple (maximum).
 - The total available current from the SPS is 9 A. Any current used for card power by modules plugged into the PDI, as well as any auxiliary 24 VDC current, must be deducted from the total 9 A available current.
 - Terminal designations “+” and “-” are for the alarm state not the supervision state.
-

Continued on next page

SPS NAC Field Wiring Guidelines, *Continued*

Class A NAC Wiring

To connect the SPS to reverse-polarity, non-addressable notification appliances using Class A wiring, read the following instructions and refer to the figure below.

1. Route wire (between 0.75 mm² and 4 mm²) from the “B+”, “B-”, outputs on TB2 of the SPS to the appropriate inputs on a peripheral notification appliance. Use NAC1, NAC2, or NAC3 as configured..
2. Route wire from the first appliance to the next one. Repeat for each appliance.
3. Route wire from the last appliance to the A+ and A- inputs on the same NAC circuit of TB1 of the SPS.
4. Repeat steps 1 through 3 for each NAC output you want to use.
5. Leave the 10 K, ½ W, brown/black/orange resistor (378-030) on each the “B+” to “B-” terminals of each unused NAC. No external end-of-line resistor is needed for circuits in use.
6. If the appliance/device to be used does not have an integral diode, a sufficiently rated blocking diode must be fitted between the incoming +ve wire and the +ve terminals of the device with cathode to the device.

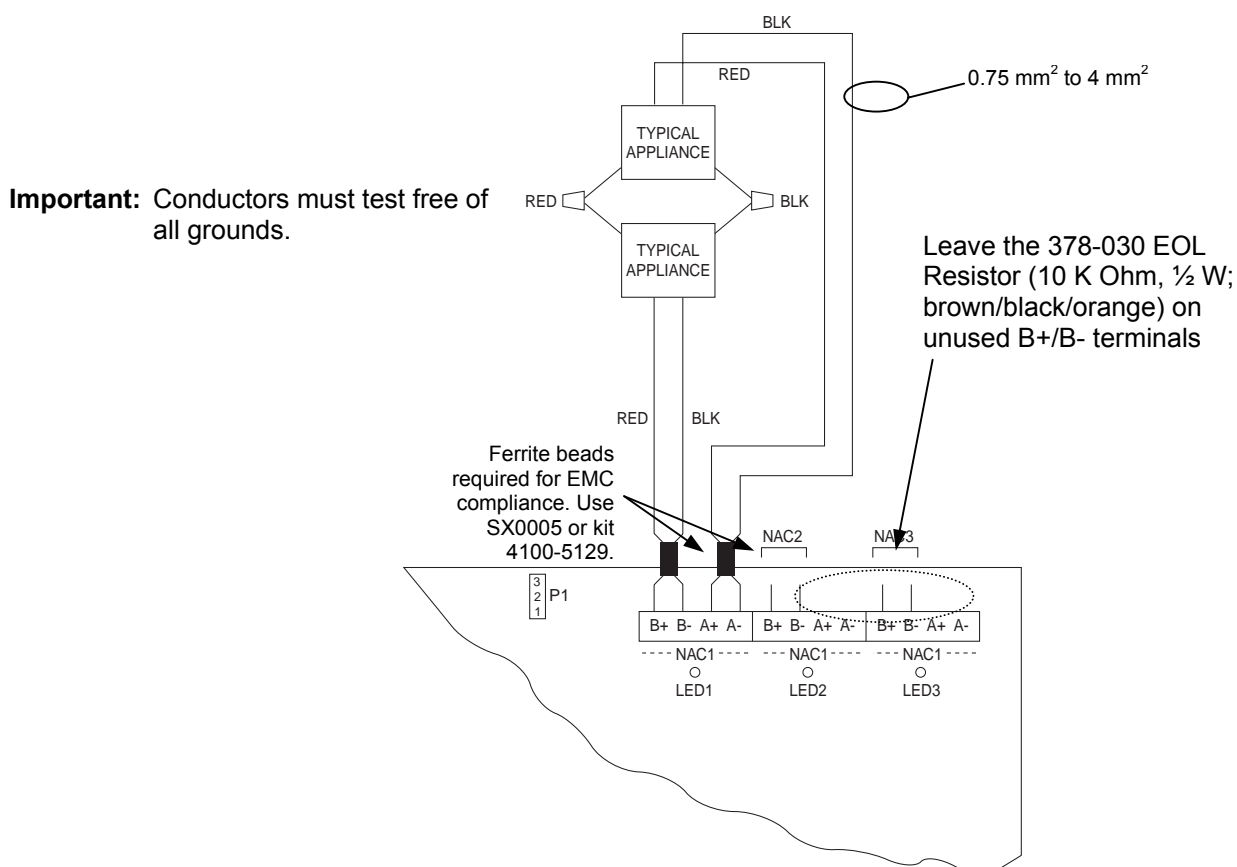

Figure 7-2. Class A NAC Wiring

Continued on next page

SPS NAC Field Wiring Guidelines, *Continued*

Class B NAC Wiring

To connect the SPS to appliances using Class B wiring, read the following instructions and refer to the figure below.

1. Route wire (between 0.75 mm² and 4 mm²) from the B+, B- outputs on TB2 of the SPS to the appropriate inputs on a peripheral notification appliance. Use NAC1, NAC2, or NAC3, as configured.
2. Route wire from the first appliance to the next one. **“T” tapping is not allowed.** Repeat for each appliance.
3. Route wire from the last appliance to the supplied EOLR or a 4081-9008 EOL Harness (10 K Ohm, ½ W; brown/black/orange).
4. Repeat steps 1 through 3 for each NAC output you want to use.
5. Leave the 378-030 EOL Resistor (10 K Ohm, ½ W; brown/black/orange) on each unused circuit. The circuit must connect “B+” to “B-” terminals.
6. If the appliance/device to be used does not have an integral diode, a blocking diode must be fitted between the incoming +ve wire and the +ve terminals of the device with cathode to the device.

The illustration below shows Class B wiring.

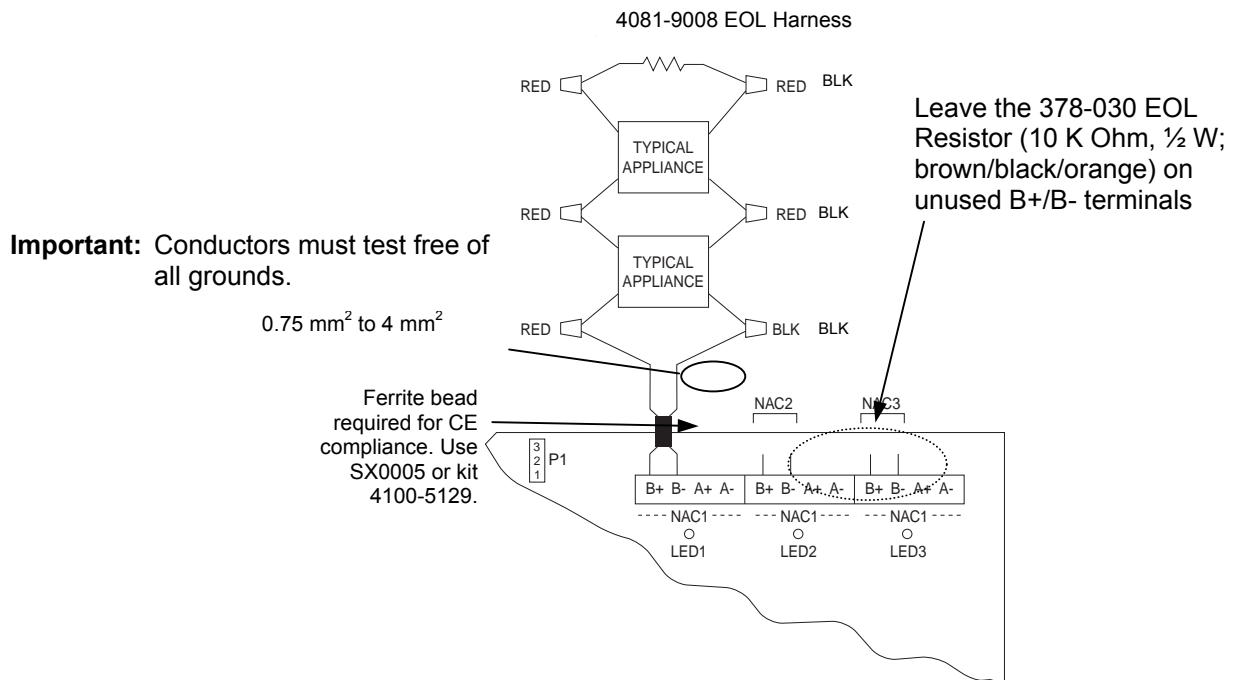

Figure 7-3. Class B Wiring

Power Supply Wiring Distances

Overview

Before wiring from any type of power supply to notification appliances, check Tables 7-1 and 7-2 for wiring distances.

**Class A NAC
Wiring Table**

Table 7-1 lists the maximum distances from the NAC terminal block to the last appliance in a Class A configuration, depending on wire gauge and current. Use Table 7-1 to calculate wire distances for your application if you are using Class A wiring.

Table 7-1. Class A Wiring Distances

Alarm Current @ 24 V	Max Distance w/ 18 AWG (0.8231 mm ²)	Max Distance w/ 16 AWG (1.309 mm ²)	Max Distance w/ 14 AWG (2.081 mm ²)	Max Distance w/ 12 AWG (3.309 mm ²)	DC Resistance
0.25 A	420 ft. (128 m)	667 ft. (203 m)	1,063 ft. (324 m)	1,691 ft. (515 m)	6 Ohms
0.50 A	210 ft. (64 m)	334 ft. (102 m)	532 ft. (162 m)	845 ft. (258 m)	3 Ohms
0.75 A	140 ft. (43 m)	222 ft. (68 m)	354 ft. (108 m)	564 ft. (172 m)	2 Ohms
1 A	105 ft. (32 m)	167 ft. (51 m)	266 ft. (81 m)	423 ft. (129 m)	1.5 Ohms
1.25 A	84 ft. (26 m)	133 ft. (41 m)	213 ft. (65 m)	338 ft. (103 m)	1.2 Ohms
1.50 A	70 ft. (21 m)	111 ft. (34 m)	177 ft. (54 m)	282 ft. (86 m)	1 Ohm
1.75 A	60 ft. (18 m)	95 ft. (29 m)	152 ft. (46 m)	242 ft. (74 m)	0.86 Ohm
2 A	53 ft. (16 m)	83 ft. (25 m)	133 ft. (41 m)	211 ft. (64 m)	0.75 Ohm
2.25 A	47 ft. (14 m)	74 ft. (23 m)	118 ft. (36 m)	188 ft. (57 m)	0.67 Ohm
2.50 A	42 ft. (13 m)	67 ft. (20 m)	106 ft. (32 m)	169 ft. (51 m)	0.60 Ohm
2.75 A	38 ft. (12 m)	61 ft. (19 m)	97 ft. (30 m)	154 ft. (47 m)	0.55 Ohm
3 A	35 ft. (11 m)	56 ft. (17 m)	89 ft. (27 m)	141 ft. (43 m)	0.50 Ohm

Notes:

- Max Distance = distance from SPS/RPS to last appliance.
- This table is calculated at 49 degrees Centigrade (120 degrees Fahrenheit). If you are installing in locations that could be exposed to higher temperatures, refer to NEC Tables 7 and 8 in NFPA code, or applicable local standard.
- Distances are based on a 3 V drop, and take into account the worst-case panel output voltage. These distances are worst case to allow for one single load at the furthest point.
- If circuit integrity wire is used instead of housing cable in a fire-rated enclosure, reduce wiring distances by 38 feet (12 m) for every 10 feet (3 m) of potential exposure.
- For other wire gauges (e.g. 4 mm²) multiply the distance specified for the nearest wire size by the ratio of the wire area, e.g. for 3A on 4 mm² look up 3A on 12AWG (3.3 mm²) and multiply the resulting 43m x 4.0/3.3 = 52m.

Continued on next page

Power Supply Wiring Distances, *Continued*

Class B NAC Wiring Table

Table 7-2 lists the maximum distances from the NAC terminal block to the last appliance in a Class B configuration, depending on wire gauge and current. Use Table 7-2 to calculate wire distances for your application if you are using Class B wiring.

Table 7-2. Class B Wiring Distances

Alarm Current @ 24 V	Max Distance w/ 18 AWG (0.8231 mm ²)	Max Distance w/ 16 AWG (1.309 mm ²)	Max Distance w/ 14 AWG (2.081 mm ²)	Max Distance w/ 12 AWG (3.309 mm ²)	DC Resistance
0.25 A	840 ft. (256 m)	1,335 ft. (407 m)	2,126 ft. (648 m)	3,382 ft. (1,031 m)	12 Ohms
0.50 A	420 ft. (128 m)	667 ft. (203 m)	1,063 ft. (324 m)	1,691 ft. (515 m)	6 Ohms
0.75 A	280 ft. (85 m)	445 ft. (136 m)	709 ft. (216 m)	1,127 ft. (344 m)	4 Ohms
1 A	210 ft. (64 m)	334 ft. (102 m)	532 ft. (162 m)	845 ft. (258 m)	3 Ohms
1.25 A	168 ft. (51 m)	267 ft. (81 m)	425 ft. (130 m)	676 ft. (206 m)	2.4 Ohms
1.50 A	140 ft. (43 m)	222 ft. (68 m)	354 ft. (108 m)	564 ft. (172 m)	2 Ohms
1.75 A	120 ft. (37 m)	191 ft. (58 m)	304 ft. (93 m)	483 ft. (147 m)	1.71 Ohms
2 A	105 ft. (32 m)	167 ft. (51 m)	266 ft. (81 m)	423 ft. (129 m)	1.5 Ohms
2.25 A	93 ft. (28 m)	148 ft. (45 m)	236 ft. (72 m)	376 ft. (115 m)	1.33 Ohms
2.50 A	84 ft. (26 m)	133 ft. (41 m)	213 ft. (65 m)	338 ft. (103 m)	1.2 Ohms
2.75 A	76 ft. (23 m)	121 ft. (37 m)	193 ft. (59 m)	307 ft. (94 m)	1.09 Ohms
3 A	70 ft. (21 m)	111 ft. (34 m)	177 ft. (54 m)	282 ft. (86 m)	1 Ohm

Notes:

- Max Distance = distance from SPS or RPS to last appliance.
- This table is calculated at 49 degrees Centigrade (120 degrees Fahrenheit). If you are installing in locations that could be exposed to higher temperatures, refer to NEC Table 7 and 8 in NFPA code, or applicable local standard.
- Distances are based on a 3 V drop, and take into account the worst-case panel output voltage. These distances are worst case to allow for one single load at the furthest point.
- If circuit integrity wire is used instead of housing cable in a fire rated enclosure, reduce wiring distances by 38 feet (12 m) for every 10 feet (3 m) of potential exposure.
- For other wire gauges (e.g. 4 mm²) multiply the distance specified for the nearest wire size by the ratio of the wire area, e.g. for 3A on 4 mm² look up 3A on 12AWG (3.3 mm²) and multiply the resulting 86m x 4.0/3.3 = 104m.

Continued on next page

SPS Auxiliary Power Wiring

Overview

The panel, battery-backed, unregulated dc bulk power is available from the SPS via the NAC and the 24V Aux power terminals (1 pair only, ref fig 7-4). NACs not configured as switched outputs may be configured as auxiliary power point type in the 4100 Programmer. All of these are power-limited.

Guidelines

Review the following guidelines before using the SPS for auxiliary power.

- Voltage rating: 24 VDC (nominal), 2 V P-P ripple (maximum).
- The total auxiliary current available for non-alarm is 5 A. The total current available for the entire SPS is 9 A, including NAC, auxiliary, and card power.
- All wiring is 0.75 mm² to 4 mm².
- All SPS powered field wiring requires a ferrite bead (ref fig 7.1).
- All wiring that leaves the building requires overvoltage protection. Install module 2081-9044 wherever wire enters or exits the building. A maximum of four 2081-9044 Modules may be connected to one channel.
- When a NAC is configured as an auxiliary power circuit, no end-of-line resistor is used.
- External wiring is not supervised unless an end-of-line relay is wired, coil to auxiliary power, and Normally Open contacts are monitored by a system power point. Relay current must be considered as part of the load.
- Programming is required for the dedicated Auxiliary Power output (TB3).
- The following devices may be connected to the 2 A Auxiliary Power:
 - 2088-series relays and door holders
 - 2098-series four-wire smoke detectors
 - 2190-series monitor and signal ZAMs
 - 4090-series IDNet ZAMs
 - 4098-series four-wire smoke detectors and duct detectors
 - 2190-9039 Printer
 - 4190-9050/9051 4-20 mA ZAMs
 - 4603-9101 LCD Annunciator
- The Auxiliary Power output is rated at 2 A dc.
- Where multiple loads are to be connected with individual protection, a Fused DC Distribution board may be fitted directly to the SPS bracket adjacent to TB3.

Continued on next page

SPS Auxiliary Power Wiring, *Continued*

Wiring

The SPS can connect to auxiliary power appliances via the dedicated auxiliary power tap (TB3). If more power is needed, any of the three NAC outputs can be used for EMC auxiliary power.

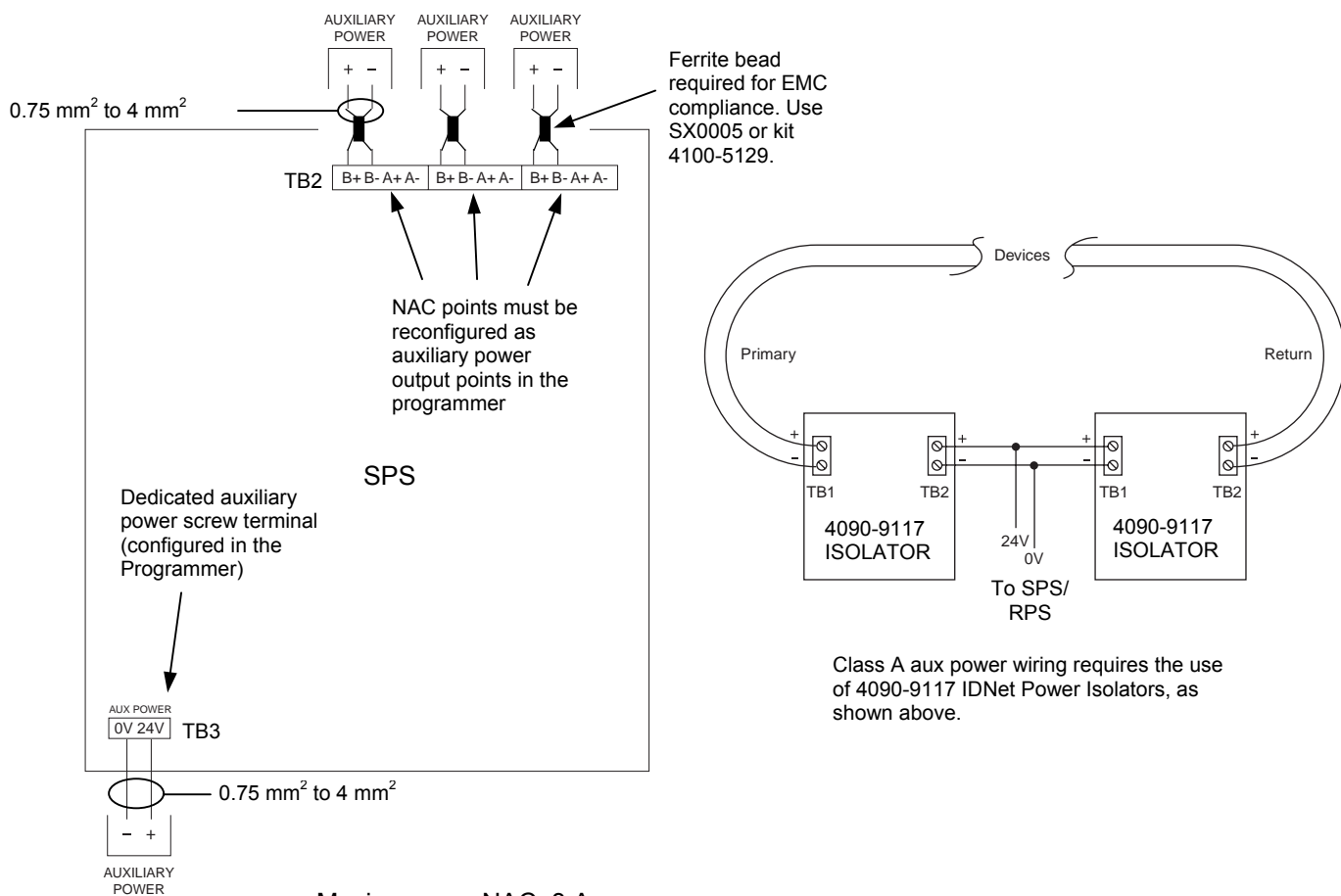

Class A aux power wiring requires the use of 4090-9117 IDNet Power Isolators, as shown above.

- Maximum per NAC: 3 A
- Maximum per Auxiliary Power output: 2 A
- Class A wiring is possible only if 4090-9117 Power Isolators are used.
- EMC compliant systems require ferrite beads. Use kit SX0005.

Figure 7-4. Auxiliary Power Wiring

SPS Relay Wiring

Overview

The SPS has one programmable relay, Aux 1, with one set of voltage-free contacts (see below). It also has provision for mounting a 4100-6033 Alarm Relay that has 3 relays, each with one set of normally open (or normally closed) contacts available on a screw terminal block (see fig 6.1).

Aux 1 Relay

- The relay must be configured in the Programmer.
 - The relay circuit is rated to switch 2 A at 30 VAC or 32 VDC, resistive load.
 - Relay contacts are Form C voltage-free contacts (but with a 40V transorb from common to Earth. Do not switch voltages greater than the rating, or damage may result.
 - When power through the relay contacts is provided by the SPS 2 A Auxiliary Power, wiring is power-limited.
 - The relay circuit is not supervised.
-

Alarm Relay Card

The three relays have default functions of Fault (trouble), Isolate (supervisory) and Alarm, and are typically used for Brigade Signalling (refer to chpt 10).

- The relays may be configured by the Programmer for alternate functions.
 - If used as Brigade relays, the jumper must be fitted to the bottom position on P3 on the SPS. If Fault (trouble) is programmed for an alternate function it must be fitted to the top position.
 - Only one pair of contacts is available for each, and is configured as normally open (NO) or normally closed (NC) by fitting a jumper on the adjacent headers P1 (Alarm), P2 (Isolate) and P3 (Fault). Use top position for NC and bottom position for NO.
 - The relays are each fuse protected (fuse 5 x 15mm, rating 3 A).
 - Relays are not supervised.
-

Continued on next page

SPS Auxiliary Relay Wiring, *Continued*

Relays

The Figure below shows the SPS relays.

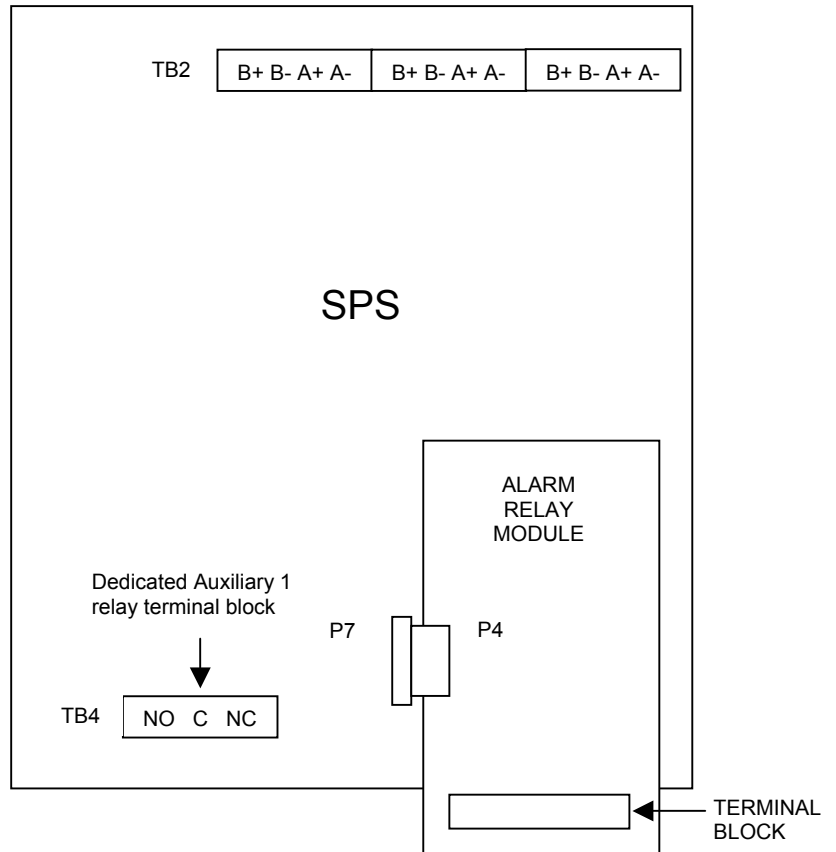

Figure 7-5. Auxiliary Relay & Alarm Relay Card Relays

SPS IDNet Wiring

Overview

This section describes how the IDNet on the SPS connects to addressable devices/detectors.

The guidelines governing IDNet wiring guidelines are covered in chpt 8, IDNet Installation.

IDNet Wiring

Up to 250 IDNet initiating devices are supported on the SPS IDNet channel. The SPS supports both Class A (loop) and Class B(string) wiring. Class A wiring is mandatory for connection to more than 40 devices.

Class A wiring allows IDNet appliances to communicate with the SPS even in the event of an open circuit somewhere in the loop. Class A wiring requires that two wires are routed from the SPS to each IDNet appliance, and then back again to the SPS.

Class B wiring allows “T” tapping, and therefore requires less wiring distance per installation than Class A. Note that Class B wiring does not require end-of-line resistors, because each IDNet appliance communicates directly to the SPS.

Guidelines

Ferrite beads are required on the SPS IDNet cables (ref Fig 7.1). Refer to chpt 8 IDNet Installation for the guidelines governing IDNet wiring.

Continued on next page

SPS IDNet Wiring, *Continued*

Class A Wiring

To connect addressable devices/detectors to the SPS IDNet using Class A wiring, read the following instructions.

1. Ferrite beads are required on the SPS IDNet cables (ref Fig 7.1).
2. Route wire (between 0.75 mm² and 4 mm²) from the B+, B- outputs on TB1 of the SPS to the appropriate inputs on a peripheral IDNet device.
3. Route wire from the first IDNet device to the next one. Repeat for each device.
4. Route wire from the last IDNet device to the A+ and A- inputs on TB1 of the SPS.

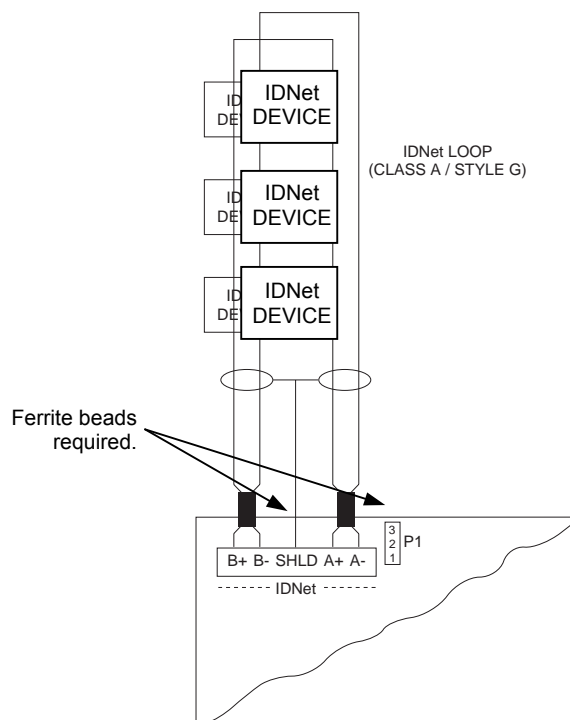

Figure 7-6. Class A Wiring

Continued on next page

SPS IDNet Wiring, *Continued*

Class B Wiring

To connect addressable devices/detectors to the SPS IDNet using Class B wiring, read the following instructions.

1. Under AS1670.1 Class B wiring is allowed only for a maximum of 40 addressable devices.
2. A ferrite bead is required on the SPS IDNet cable.
3. On TB1, jumper B+ to A+, and jumper B- to A-.
4. Route wire (between 0.75 mm² and 4 mm²) from the B+, B-.

The illustration below shows Class B wiring.

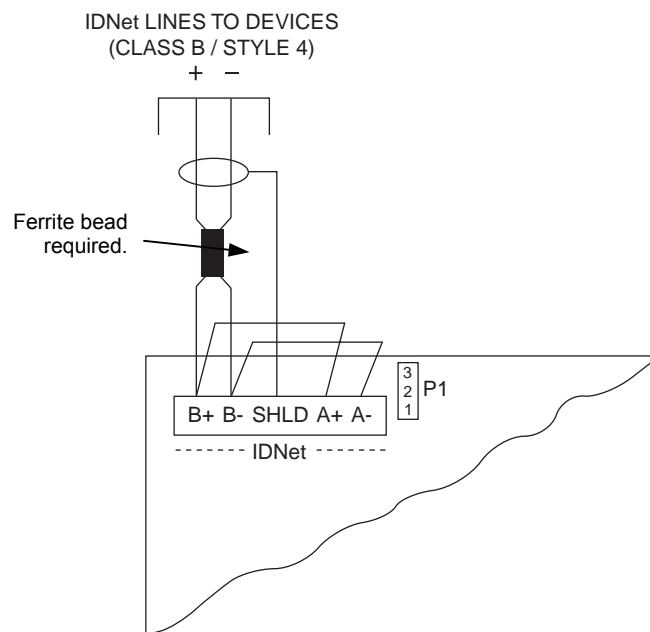

Figure 7-7. Class B Wiring

Chapter 8

Installing 4100U IDNet & 4100MXP Cards

Introduction

Two loop cards are available in the 4100U 4"x 5" card format. These plug directly onto the PDI and form an intelligent interface between the 4100U CPU and one loop of addressable detectors/devices.

The IDNet Card uses Mapnet Protocol and communicates with existing Mapnet detectors/devices plus the new IDNet devices.

The 4100MXP communicates with the Tyco MX range of detectors/devices.

In this Chapter

Refer to the page number listed in this table for information on a specific topic..

Topic	See Page #
The IDNet Card	8-2
Installing the IDNet Card onto the PDI	8-4
Installing the ID-Net into a 4100 Card Bay	8-5
Configuring the Card	8-6
Wiring to IDNet Devices	8-7
Troubleshooting on IDNet	8-10
The 4100MXP	8-11

The IDNet Card

Overview

The 4100U IDNet card receives 24V power (+24V Card Supply bus) and coms (i.e. communication with the CPU) via the PDI. There are several versions, configured by links soldered on the pcb. The 4100-3101 used in Australia, communicates with up to 250 devices. An IDNet card may be fitted to a 4100 (non-U) bay in an upgrade panel by use of a bracket and interface pcb plus 4100 style power and coms wiring harness.

The part number for the IDNet card, plus Interface bracket is KT0452.

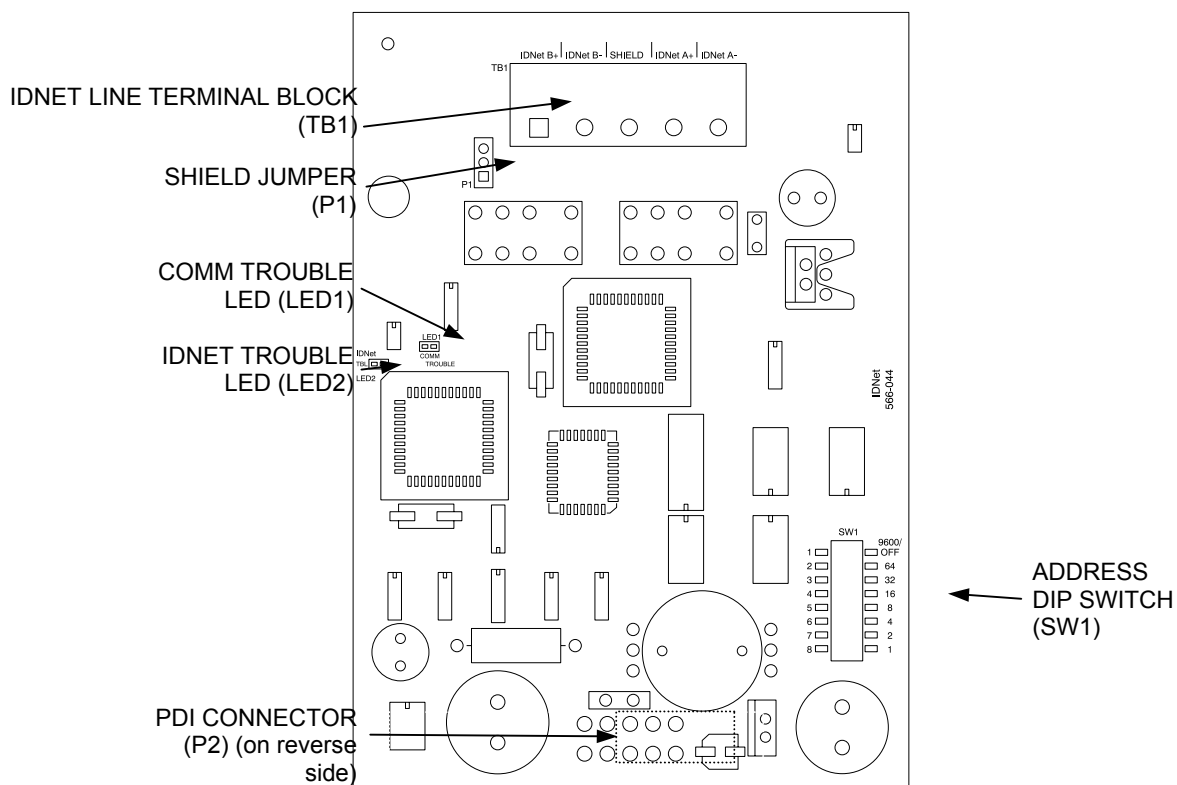

Figure 8-1. The IDNet Card

The IDNet Card, *Continued*

LEDs

The IDNet card has the following LEDs:

LED1. Normally off. Turns on steady if the IDNet card is not communicating with the 4100 CPU.

LED2. Normally off. Illuminates to indicate a problem with the IDNet lines.

- Steady on indicates channel failure.
- One repetitive blink indicates a line short.
- Two repetitive blinks indicate a Class A failure or an open line.

Specifications

Table 8-1. IDNet Specifications

Electrical Specifications	
Input Voltage	24 VDC nominal from FACP (24V Card Supply from SPS)
Coms/Power Voltage to IDNet Slaves	30 VDC (nominal) or 35 VDC @ 250 mA 36.5V max (See below)
Coms/Power Current Limit	350mA ave current @ 49° C
Coms/Power Wiring Distance	40 Ohms max loop resistance 0.58 μ F capacitance max (line to line and shield to line)
Environmental Specifications	
Operating Temperature	0° to 50° C

- Voltage output to IDNet is normally 30 VDC. Output is increased to 35 VDC when LEDs, piezos, or other outputs are activated, as in the alarm state.
- The 30/35V PSU on the IDNet is rated at greater than 350mA. The current limit is provided by a PTC.
- Up to 250 IDNet devices are supported by one IDNet channel.
- The IDNet card keeps track of which LEDs should be on at all times, and displays up to 20 at any given time.
- Up to 43 coded piezo sounders are supported by one IDNet channel.

Installing the IDNet Card onto the PDI

Overview

The 4100-series IDNet card is designed to be mounted on the PDI in a 4100U expansion cabinet. The card can be mounted on any of the PDI connectors.

Use connector P2, labeled on the back side of the IDNet card, to connect to any of the eight PDI connectors as shown in the figure below.

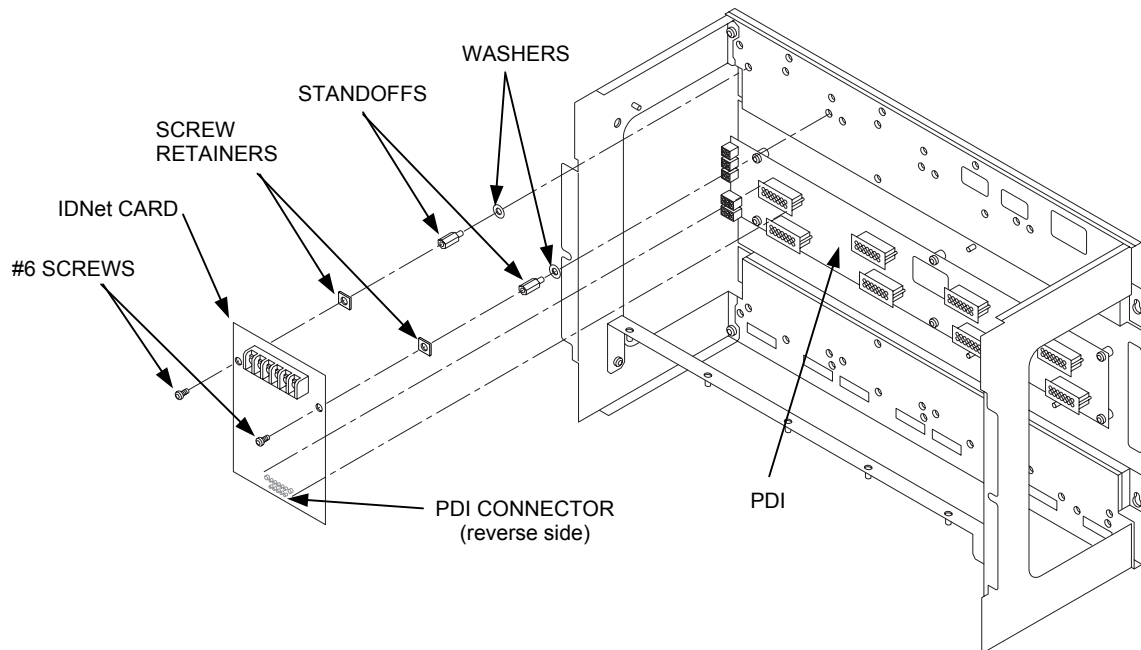

Figure 8-2. Mounting onto the Power Distribution Interface

Installing the ID-Net into a 4100 Card Bay

Overview

If a 4100 is upgraded to 4100U, IDNet cards can be fitted to existing 4100 bays by use of the Interface Card plus bracket. The bracket mounts to the bay as a 4100 card motherboard does and takes up 1 slot.

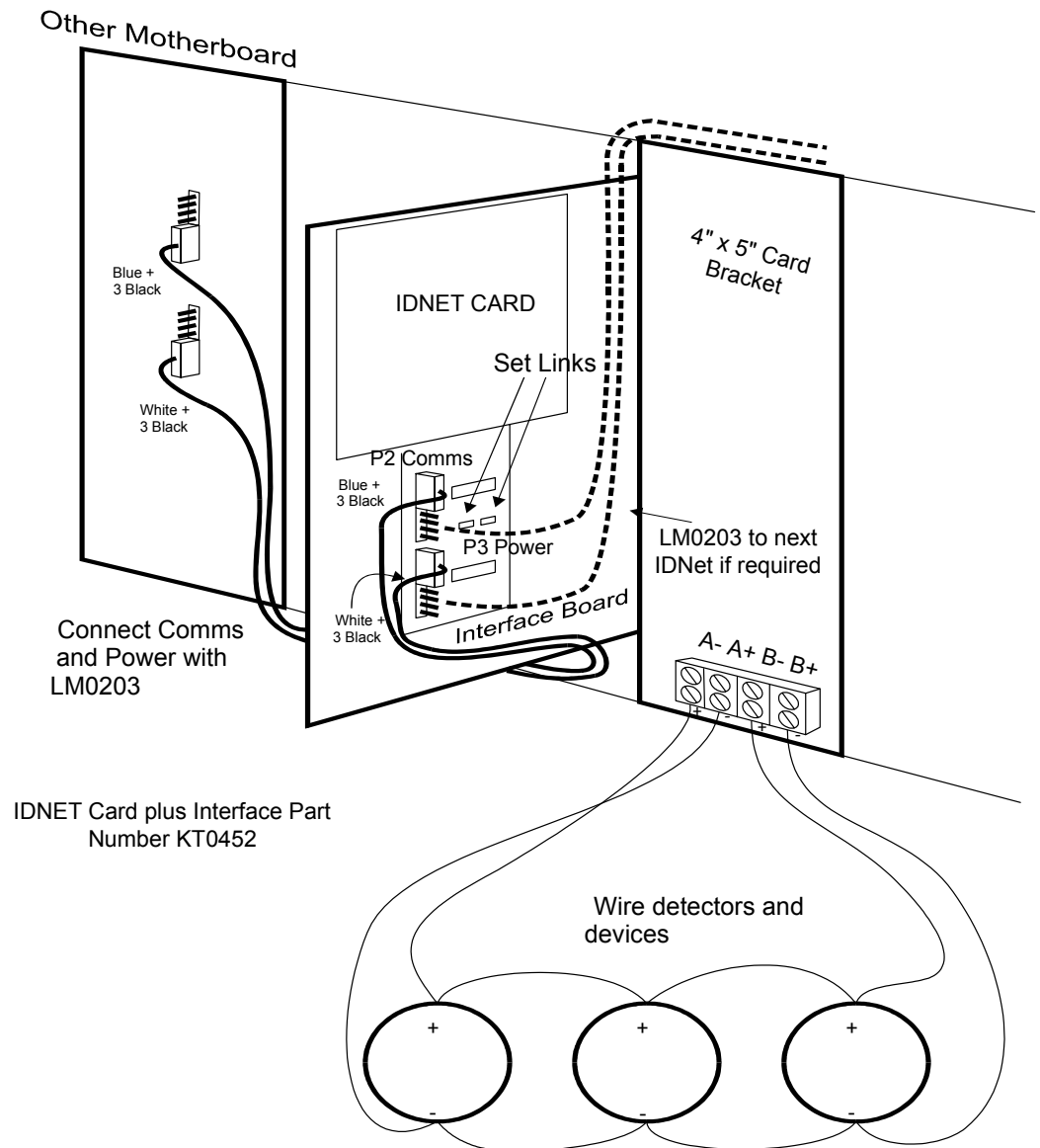

Figure 8-3. Mounting into 4100 (legacy) Bay

Configuring the Card

Overview

Configuring the card consists of selecting the shield tie point, and setting the device address..

Setting the Shield Tie Point

If a shielded cable is used, connect the cable shield to the dedicated terminal on TB1 and use jumper port (P1) to select where the shield will be tied.

- Position 1 - 2 connects the shield to 0 V.
 - Position 2 - 3 connects the shield to Earth.
-

Setting the Address

The device address is set on DIP switch SW1, which is a bank of eight switches (see figure below). From left to right, these switches are designated as SW1-1 through SW1-8. The function of these switches is as follows:

- **SW1-1.** This switch sets the baud rate for the internal 4100 communications line running between the card and the 4100 CPU. Set this switch to ON.
- **SW1-2 through SW1-8.** These switches set the card's address within the 4100 FACP. Refer to the table in Appendix A for a complete list of the switch settings for all of the possible card addresses.

Note: You must set these switches to the value assigned to the card by the 4100 Programmer.

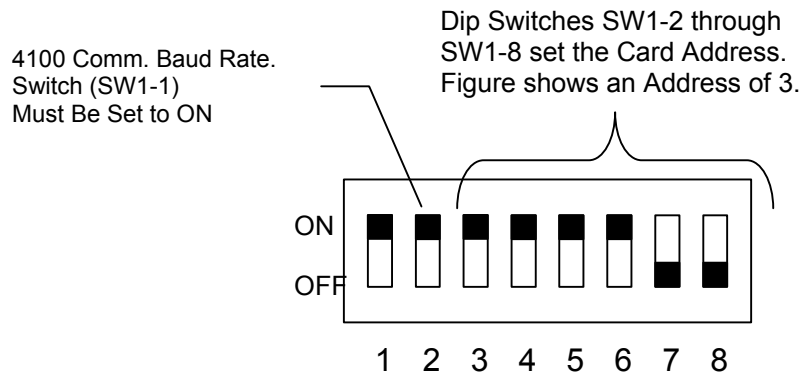

Figure 8-4. DIP Switch SW1

Wiring to IDNet Devices

Overview

Up to 250 IDNet slave devices, such as smoke detectors and manual call points, can be connected to the IDNet card using Class A (loop) or Class B (line) wiring, with the following restrictions.

Class A wiring allows the devices to communicate with the IDNet card even in the event of an open circuit somewhere in the loop. Class A wiring requires that two wires are routed from the IDNet card to each IDNet device, and then back again to the IDNet card. Under AS1670.1 every group of 40 devices (or less) must be separated by a Comms Isolator.

Class B wiring allows “T” tapping, and therefore requires less wiring distance per installation than Class A. IDNet wiring does not require end-of-line resistors, because each IDNet device communicates directly to the IDNet card. A maximum of 40 devices is allowed to be connected this way.

See Appendix F for a list of compatible devices and their ratings.

Guidelines

- Use ferrites. See Fig 7.1.
 - Shielded cable is recommended in electrically noisy environments.
 - IDNet cabling should not be run adjacent to other cabling, especially non-fire system cabling, e.g. mains.
 - The limiting factors of the 2 core cable connecting the IDNet devices to the IDNet Card are cable capacitance (attenuates the superimposed coms signal) and resistance (causes voltage drop of the supply voltage and comms signals).
 - The maximum capacitance of 0.58uF core to core must also include the mutual capacitance of core to earth. The latter is greatly increased when shielded cable is used.
 - Rather than do voltage drop calculations (see notes following), the following simplified rules are applied.
 - Allow a maximum of 40Ω to any device (Class B), and in any loop (Class A) with 125 devices or less.
 - Allow a maximum of 20Ω in any loop with 250 devices.
 - Linear de-rating between 40Ω and 20Ω may be applied between 125 devices and 250 devices. Use $R_L = 20\Omega \times (1 + (250-n)/125)$ where R_L is the allowable line resistance and n is the number of devices used. E.g. for 200 devices the maximum resistance allowed may be extended from 20Ω to: $20\Omega + 20\Omega \times (250 - 200) / 125 = 28\Omega$
 - Use the resistance specifications that apply to the cable being used. The values used in this manual allow 39Ω per km for 2 core of 1 mm² for copper wire at 49°C. (A commonly used value is 34Ω per km for 2 core of 1 mm² at 20°C). See Table 8.1. Note that this includes both cores.
 - Sounder bases and 6 point I/O modules do not draw the alarm load from the loop, but are powered from separate 24V terminals.
 - Where devices, e.g. sounder bases, are wired from a 24V source (e.g. supplied by 24V Aux Power or a NAC), and are in more than 1 zone, the power cable must also be isolated between zones by a 4090-9117AU Power Isolator Module.
-

Continued on next page

Wiring to IDNet Devices, *Continued*

Table 8-2 Cable Run Lengths

Wire Size	0.75 mm ²	1 mm ²	1.5 mm ²	2.5 mm ²	4 mm ²	Resistance
Distance	385 m	513 m	769 m	1,282 m	2,052 m	20Ω
Distance	769 m	1,026 m	1,538 m	2,565 m	4,104 m	40Ω

Notes

1. The circuit allowance per device on the loop is 0.5mA with the LED off, 2mA with the LED on. A maximum of 20 LEDs get turned on at one time by IDNet Card (i.e. in alarm).
2. The minimum voltage allowed at the furthest device to guarantee operation is 24.9Vdc. The IDNet boosts its output voltage from nominal 30V to nominal 35V during alarm.

Class A Wiring

To connect the IDNet card to devices using Class A wiring, read the following instructions and refer to the figure below.

1. Route wire between 0.75 mm² and 4 mm² from the IDNetB+, IDNetB- outputs on TB1 of the IDNet card to the appropriate inputs on a peripheral IDNet device.
2. Route wire from the first IDNet device to the next one. Repeat for each appliance.
3. Route wire from the last IDNet device to the IDNetA+ and IDNetA- inputs on TB1 of the IDNet card.
4. Separate every 40 devices (maximum) with a coms isolator (e.g. 4090-9116).
5. Separate sounder bases or 6 point I/O modules in zones using the 4090-9117 Power Isolate module.

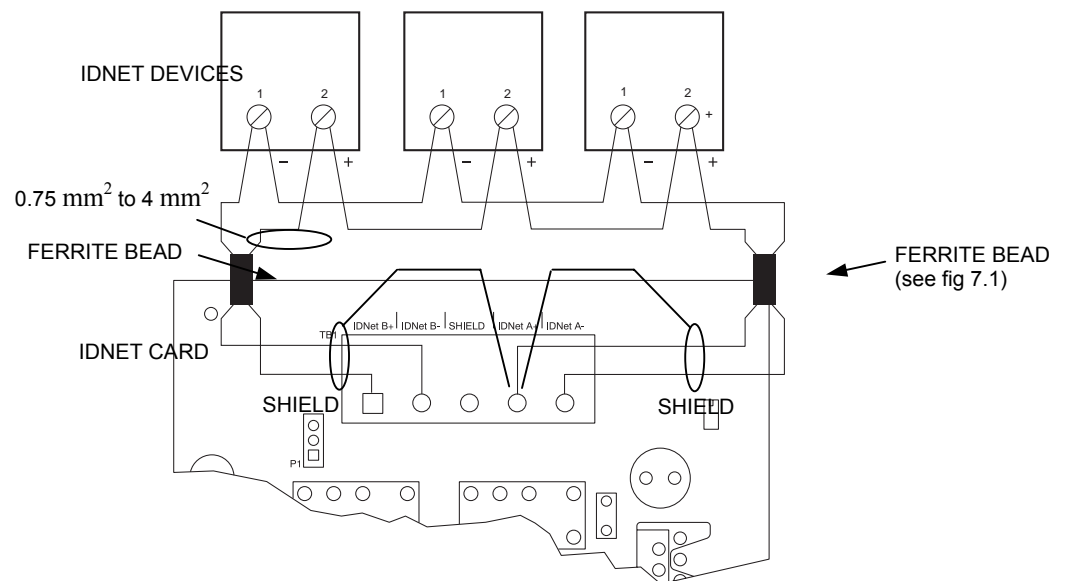

Figure 8-5. Class A Wiring

Continued on next page

Wiring to IDNet Devices, *Continued*

Class B Wiring

To connect the IDNet card to appliances using Class B wiring, read the following instructions.

1. On TB1, jumper IDNetB+ to IDNet A+, and jumper IDNetB- to IDNetA-. If the jumper is absent, a Class A Trouble will be indicated on LED 2.
2. Route wire between 0.75 mm^2 and 4 mm^2 from the IDNetA+, IDNetA-, (or B+, B-) outputs on TB1 of the IDNet card to a junction box. Begin "T" tapping at the junction box.
3. Up to 40 devices maximum.
4. Sounder bases or 6 Point I/O modules in separate zones may not be wired in Class B.

The illustration below shows Class B wiring.

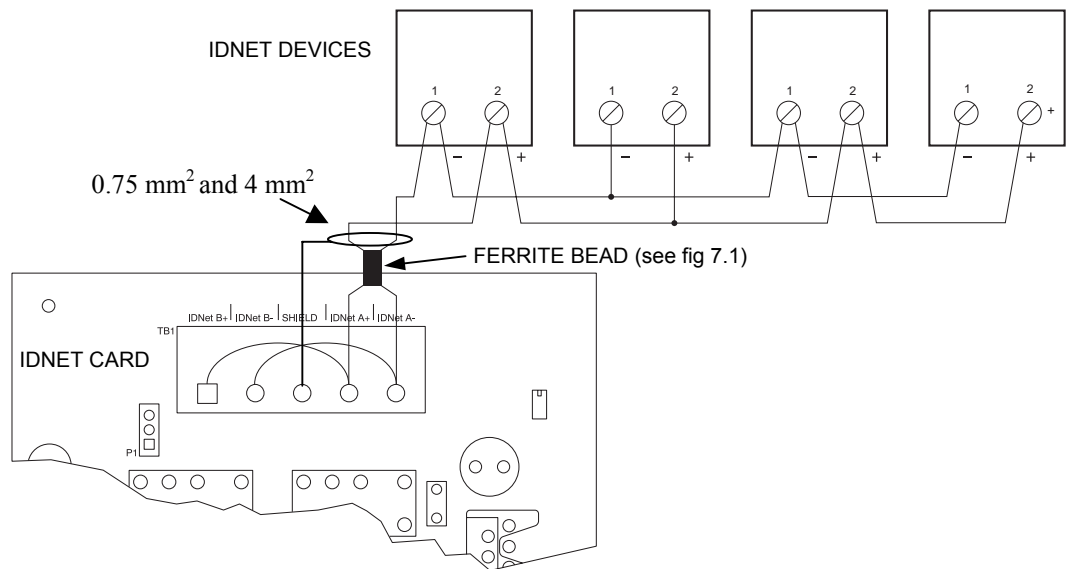

Figure 8-6. Class B Wiring

Note: Maintain correct polarity on terminal connections. Do not loop wires under terminals.

Troubleshooting on IDNet

Overview	This section describes the messages that may appear on the 4100 display when using the IDNet card. Trouble messages appear on the left as titles, and possible causes are listed to the right in the text.
IDNet Power Monitor Trouble	There is no output voltage from the IDNet power supply. Replace the IDNet card.
Extra Device	Appears if one or more extra devices (i.e., devices that have not been configured for the IDNet channel) are found on the system, or if a device is at an incorrect address. Only one message appears, regardless of the number of extra devices found. Viewing the trouble log will reveal the extra device address.
Class A Trouble	There is an open on the IDNet channel. After fixing the wiring fault, a hardware reset is required to reset the trouble.
Earth Fault Search	Appears while the IDNet card is searching for earth faults on the IDNet line. When this message is displayed, the IDNet card cannot show any alarms or other statuses.
Short Circuit	Appears when a short is detected on the IDNet channel. This status clears automatically when the short circuit is removed.
Channel Fail	Appears when devices have been configured, but none of the devices are communicating on the channel. This message does not appear if there are no configured devices on the IDNet channel.
No Answer	Appears when a device is missing.
Bad Answer	Appears when there is a faulty device or a noisy communications channel.
Output Abnormal	Occurs during any of these conditions: 24 V is not present on TrueAlarm devices. TrueAlarm sensor bases with relay driver outputs are not properly supervised. Isolator devices are in isolation mode.

The 4100MXP

Introduction

The 4100MXP is a 4" x 5" card, similar to the IDNet, but allows the 4100U to communicate with a Loop of MX devices. The firmware in the 4100U sees the 4100MXP as an IDNet, and all the MX devices are matched to the nearest Simplex device.

Power Connection

The main difference of 4100MXP from IDNet is that it has a nominal 40V loop supply voltage and is capable of supplying up to 1A of loop current.

The power for this loop supply is drawn from the 24V Signal bus, which is only present on the PDI when an XSPS is directly attached to it.

Details of the 4100MXP is provided in manuals LT0313 and LT0314.

Chapter 9

PC Software Connections

Introduction

The service port on the door with the Operator Interface enables the 4100U to connect to PCs running important utilities, such as diagnostics, programming, CPU firmware downloading, and channel monitoring.

In this Chapter

Refer to the page number listed in this table for information on a specific topic.

Topic	See Page #
Software Modes	9-2

Software Modes

Overview

The 4100U can connect to PCs running important utilities, such as diagnostics, programming, CPU firmware downloading, and channel monitoring. It connects to PCs running all of these utilities via the service port on the CPU daughter card. When a PC is located remotely from the FACP, the 4100-9832 Service Modem is used.

Software Modes

There are three basic software modes that the service port or service modem can be used to connect to:

- Service and Diagnostics Mode
- Data Transfer Interface Mode
- Master Bootloader Interface Mode

Each mode is described below.

Service and Diagnostics Mode. The default functionality when a PC is connected to the FACP. On a PC, this mode provides application startup messages, an ASCII interface to a UI command set for diagnostics, and event reporting. The PC must be running terminal emulation software (e.g., Hyperterm). Connection to a PC is made via serial port or service modem.

Important: When connecting via the service port, ensure your Flow Control is set to NONE in the Port Settings of your terminal emulator.

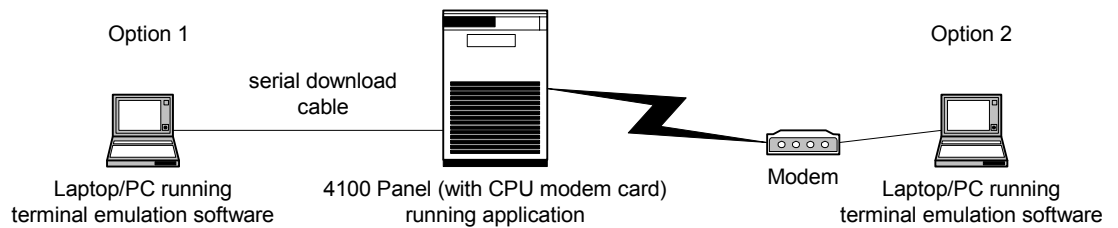

Figure 9-1. Service and Diagnostic Interface

Data Transfer Interface Mode. In this mode, the 4100 Programmer is enabled. This allows for slave downloading, as well as downloading a configuration and audio messages to the FACP, and uploading a configuration or history log from the FACP. Connection to a PC is made via serial port or service modem.

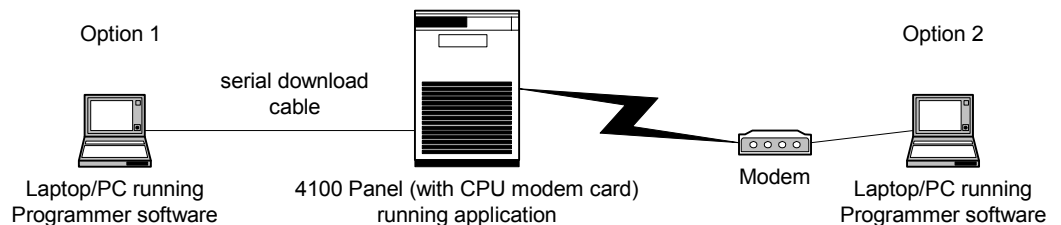

Figure 9-2. Data Transfer Interface

Note: The standard Simplex modem is not currently approved for use in Australia.

Continued on next page

Software Modes, *Continued*

Software Modes (*continued*)

Master Bootloader Interface Mode. This mode downloads the Master CPU Exec firmware and the CFG.TXT file to the CPU via the serial port.

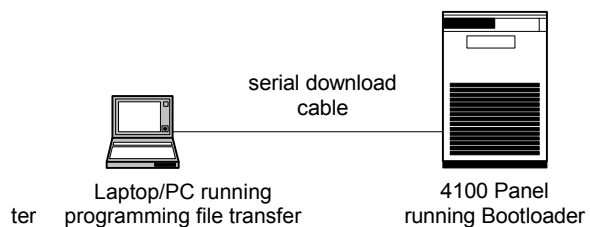

Figure 9-3. Bootloader Interface

Chapter 10

Australian Version Specifics

Introduction

This chapter provides detail on format and components that are specific to the Australian version 4100U that complies with AS4428.

In this Chapter

Refer to the page number listed in this table for information on a specific topic.

Topic	See Page #
Summary Of Australian Version Specifics	10-2
Australian Panel Format	10-3
4100U Fan Control Module	10-4
Brigade Interfaces	10-6

Summary Of Australian Version Specifics

Overview

The Australian fire alarm standards differ from those in the USA. Shipping costs from USA to Australia are significant, and the Australian market is small compared to the USA market. It is therefore necessary to:

- have an Australian specific panel format that differs from the standard USA panel format;
 - have some Australian specific components;
 - limit the number of system components available in the Australian version.
-

AS4428 Requirements

The 4100U Operator Interface does not comply with the AS4428.1 requirements for an FF (Firefighter Facility) that uses only an alphanumeric display for alarm zone status indication. The basic firmware of 4100U does not accommodate zones as described in AS4428.1. The standard SPS (System Power Supply) does not have the required charger and battery supervision and test facilities. Therefore the following are required for an Australian 4100U.

- Use a different Operator Interface front label (overlay) and keypad with “Trouble” changed to “Fault”, “Supervisory” changed to “Isolate”. This overlay is also smaller and has different text in the instructions on the bottom.
 - Use an Australian version of the message library with “Trouble” changed to “Fault”, “Supervisory” changed to “Isolate”.
 - Configure the programmable control keys and indications on the Operator Interface with the functions shown in Figure 2-7.
 - Fit 8 Switch/16 LED Red/Yellow modules such that there is one switch plus one red and one yellow LED per zone to give individual zone isolate and alarm indications.
 - Configure zone and battery test functionality in custom control.
The custom control programming requirements are covered in Appendix B.
 - Use an Australian version of the SPS (with a modified pcb and firmware). Because of low quantity, only one format is available, and this excludes the standard XPS (2 slot wide). The SPS communicates with the CPU Card. Note that in a Brigade connected FIP, the SPS controls the Brigade Interface relays. If the CPU Card fails, or if the SPS CPU fails, the Fault (Trouble) relay turns on. This watchdog action provided by the SPS is statutory.
-

Australian Panel Format

Overview

The main difference with the Australian panels is that they are assembled in the Australian (Tyco) range of rack cabinets.

Australian / USA Differences

Some further specific differences follow:

- Only the Expansion Bay is used, with the Controller CPU and Motherboard mounted in the right hand side of the first one. The standard US Controller Bay is not used.
 - The Operator Interface is fitted to an Australian specific 4U hinged bracket mounted above the first bay.
 - Australian specific bay mounting brackets and trims are used. This includes the standard range of 19" rack mount panels and brackets.
 - Only one version of SPS is available. This mounts on a specific bracket and also to an expansion bay, and is unique to Australia.
 - Only one version of IDNet card is used, ie the 4100-3101.
 - Two of the addressable modules were modified specifically for AS4428, i.e. 4090-9117AU Addressable Power Isolations, and the 4090-9120AU 6 Point I/O.
 - Other cards / modules not used in Australia include the large range of Evacuation products and some modems.
-

4100U/4100A Differences

Standard 4100 motherboards and cards fit in a 4100U bay. The following items however, do not fit:

- 4100 Switch/LED display modules;
- The range of Australian brackets that mount to the front of a 4100 bay. This includes some EWIS products, Brigade interface brackets, T-Gen bracket, and printer.
- The metal bracket that mounts into a 4100 bay (as does a Motherboard), and houses: the 25W and 50W amplifiers; the T-Gen; two MiniGens; the 1948 24V 2A PSU; or the Powerblock PSU.

A revised version of this bracket has been designed to mount the T-Gen, two MiniGens or the 1948 PSU into a 4100U bay. It does not, however, take the two amplifiers. The Powerblock. PSU is not available in this form.

Note that although 4100 cards fitted to motherboards, and the bay mounting brackets, can be fitted in directly behind Switch/LED modules, they **cannot be fitted behind the 64/64 Switch/LED Controller** mounted to the inside of the bay door. This is typically mounted behind the LED/Switch Modules fitted to the 3rd and 4th positions from the left.

4100U Fan Control Module

Overview

ME0456 is a 4100U style Switch/LED display module specifically designed for fan control. It complies with the requirements of AS1668.1, 1998. It has rotary switches and LEDs for 4 fans. In order to accommodate the required rotary switches, the front plate is joggled forward so that it protrudes through the trim.

Labeling

The Fan Control switch positions of ON, AUTO and OFF, as per the standard, are permanently marked on the faceplate label.

The labeling of the LEDs, ON, FLT, and OFF is marked on the removable fan name label card, LB0605, supplied with the module.

The card may be reversed and different LED labelling used, e.g. as required for damper controls.

The name area accommodates 3 rows of 6 letters at 5mm.

A “soft” version of this label is available on the TSP website as LB0605. This template allows entry of the fan name on a PC for local printing. LED names may also be revised.

Mounting & Connection

The Fan Control module mounts to the frame of the 4100U Expansion bay door, from the front, by the studs on the module with the nuts and washers provided.

Connection from “Out” of the adjacent Switch/LED module (or 64/64 Controller if it is the first module on that Controller) to “In” on the module is by the flat flexible cable provided (SX0039).

Programming

The Module is programmed as a standard 8 Switch/16 LED module. Up to 4 can be driven by one 64/64 Switch/LED Controller.

Each fan control with one rotary switch uses two of the 8 “switches”, and 3 of the 16 LEDs of an 8 Switch/16 LED module as per Table 1. The other 4 LEDs are not fitted so must not be programmed.

Table 10-1. Switch/LED Format

Fan Control	Switches	LEDs		
		ON	FLT	OFF
1	SW1, SW2	LD1	LD2	LD3
2	SW3, SW4	LD5	LD6	LD7
3	SW5, SW6	LD9	LD10	LD11
4	SW7, SW8	LD13	LD14	LD15

The switch functions for Fan Control 1 are shown in Table 2. The state with both switches closed is not physically achievable.

Table 10-2. Switch Status

SW1	SW2	Control Status
Closed (up)	Open (centre)	On
Open (centre)	Closed (up)	Off
Open (centre)	Open (centre)	Auto

Continued on next page

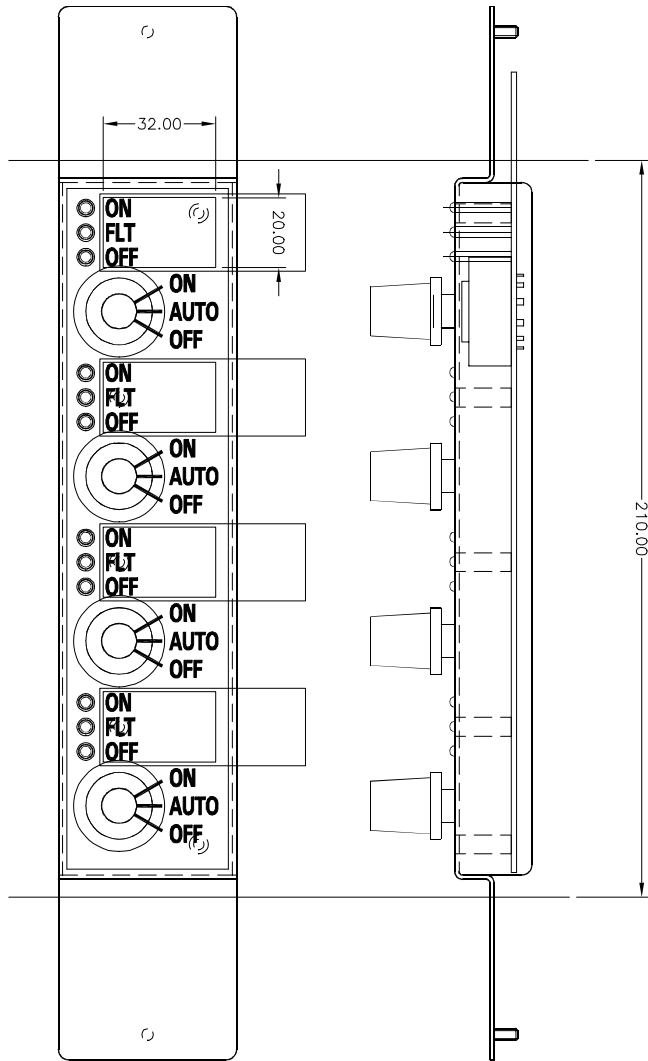

Figure 10-1. Fan Control Module

Brigade Interfaces

Overview

The Alarm Relay Card is typically used to provide a Brigade Interface. The default configuration is for the three relays to operate on Fault (Trouble), Isolate (Supervisory) and Alarm, respectively.

The connection drawings for the Centaur ASE, Western Australia AIU and Queensland PPU are included in the appendix.

Format

These relays are normally de-energised and energise on the respective status. They have voltage-free contacts that are connected to two terminals and can be configured as normally open or normally closed by the positioning of links. Refer to Chapter 6 for details.

If a normally energized relay is required to provide activation on complete loss of system power (Standby), the Aux Relay on the SPS can be programmed as normally on and its contacts connected in series/parallel with the contacts of the Fault (Trouble) relay as is applicable (ie series for normally closed, parallel for normally open). Where the Brigade interface is powered from the system power and monitored by the central station, this is not typically required.

Note that the Aux relay programmed as normally energised, de-energising on Fault cannot be used to replace the Fault relay on the Alarm Relay Card as the latter is link connected to a hardware signal of "SPS CPU Fault".

Applications

Standard rack mounting, 3U, Brigade Interface brackets are available as follows. FZ9028 includes the wiring loom. KT0199 requires KT0207 to provide the wiring loom with the encapsulated Interface (FP0740).

Where there are space limitations, eg in the 18U cabinet, an A5 document holder (KT0469) can be fitted to the 3U ASE Bracket, or the 3U AIU/PPU bracket. At 220mm wide, this document holder is only half the width of the standard one that requires a whole 3U trim.

KT0199 19", 3U ASE Mounting Bracket
KT0207 ASE FAS Interface Loom

FZ9028 19", 3U AIU/PPU Mounting Bracket and Loom

Connection for the ASE is shown in drawing 1963-62.
Connections for the AIU and PPU are shown in drawing 1901-267 sht2.

For the AIU (Western Australia) the links on the Alarm Relay Card are fitted for normally open contacts. For the PPU (Queensland) and the ASE (most other territories) the links are fitted for normally closed contacts.

Chapter 11

Installation Checklist, Commissioning & Maintenance

Introduction

When a branch designs a system and orders a 4100U panel, a “Configuration Sheet” is prepared. The factory builds the panel to the configuration sheet. This includes fitting, connecting and configuring cards and modules.

The factory programs and tests the panel to the configured sheet.

The CPU Card and any 4100 style (legacy) cards that are fitted to motherboards are then removed and packaged with the panel for shipping.

When the panel arrives on site the installers must unpack and check the panel, mount the cabinet, refit any packaged cards, and check the configuration before applying power.

A registered electrician must connect the mains. The panel should then be powered up and checked for correct operation.

With the mains turned off and the batteries disconnected, the field wiring is checked and connected to the field terminals on the various cards.

The panel should then be powered up and re-programmed to accommodate all the connected field devices. Faults in the field wiring, misaddressed detectors / devices, mismatched detectors / devices will be displayed on the LCD. These should be cleared one at a time and then the system (panel plus connected devices) should be commissioned.

In this Chapter

Refer to the page number listed in this table for information on a specific topic.

Topic	See Page #
Installation Checklist	11-2
Alignment & Adjustment	11-3
Maintenance	11-5

Installation Checklist

Overview

The following checklist should be completed by the installer. (Note that all pcbs are electronically tested and adjusted before being fitted to the FIP).

1. CABINET & GENERAL

- | | | |
|----|--|--------------------------|
| A) | Cabinet colour - Standard Cream Wrinkle (BFF 998 CW)
- Other: _____ | <input type="checkbox"/> |
| B) | Cabinet undamaged (Paint OK) | <input type="checkbox"/> |
| C) | Door aligned correctly | <input type="checkbox"/> |
| D) | Window undamaged and fitted correctly | <input type="checkbox"/> |
| F) | Cabinet Door locks firmly, operates microswitch (if fitted) | <input type="checkbox"/> |
| G) | Lock - 003 Type & two keys supplied | <input type="checkbox"/> |
| H) | Door seals fitted to top and sides | <input type="checkbox"/> |
| I) | Display Keypad and 4U door fitted & aligned correctly | <input type="checkbox"/> |
| J) | Label LB0602 fitted to l.h.s. of Operator Interface | <input type="checkbox"/> |
| K) | Card bays fitted | <input type="checkbox"/> |
| L) | Operator Manual and battery leads included | <input type="checkbox"/> |
| M) | Panel rating label completed, fitted | <input type="checkbox"/> |
| N) | AS1668 Warning label fitted if Fan Control Modules used | <input type="checkbox"/> |
| O) | Applique label fitted to front. | <input type="checkbox"/> |

2. MODULES, CARDS & WIRING

- | | | |
|----|--|--------------------------|
| A) | SPS fitted securely, pcb & components undamaged | <input type="checkbox"/> |
| B) | LED switch modules fitted correctly, spaced evenly | <input type="checkbox"/> |
| C) | FRCs connecting 64/64 Controller & modules fitted correctly | <input type="checkbox"/> |
| D) | Earth wires fitted to display door, card bays and bay front panels | <input type="checkbox"/> |
| E) | All 4100 style cards fitted to motherboards | <input type="checkbox"/> |
| F) | All 4100 style motherboards connected | <input type="checkbox"/> |
| G) | All 4" x 5" modules fitted securely | <input type="checkbox"/> |
| H) | All cards, modules addressed as per configuration sheet (see note 1 below) | <input type="checkbox"/> |
| I) | The Lithium battery is fitted to the holder on the CPU card | <input type="checkbox"/> |
| J) | Link P3 on the CPU card is fitted to the BAT ON position (see note 2) | <input type="checkbox"/> |
| K) | The CPU card is fitted to its motherboard and the 2 FRCs are connected | <input type="checkbox"/> |
| I) | All fan control zone name labels fitted. | <input type="checkbox"/> |

Notes

1. The 64/64 Controller Modules are addressed but the LED/Switch modules are not.
2. The Lithium battery on the CPU Card (Master Controller) that stores time and date is disconnected during shipping by fitting link P3 to the BAT OFF position. It must be reconnected at time of installation.

Alignment & Adjustment

Overview

All the 4100U cards and modules (pcbs) are tested and aligned in the factory before being supplied to the customer or fitted to a FIP. The only field adjustment that may be necessary is to set the battery charger voltage. (Note this has been set and should not need re-adjusting).

R341 Battery Charger Voltage

Should the battery charger voltage need adjusting, the method is as follows:

1. Run the system with the batteries connected and the door closed for at least 30 minutes to allow components to "warm up" (the longer the better).
2. Calculate the required no-load battery charging voltage by taking 27.3V for 20°C and subtracting approximately 0.1V for every 3°C above 20°C, or adding approximately 0.1V for every 3°C below 20°C.
3. With the system not in Alarm, disconnect the batteries.
4. Measure the voltage at the battery terminals and adjust to the voltage calculated in Step 2 by turning pot R341.
5. Re-connect the batteries.

Power Up & Placing into Operation

To place the 4100U FACP into operation, perform the following steps:

- STEP 1 Ensure that the Mains Isolate Switch is OFF.

- STEP 2 Ensure that 240 VAC is connected to the panel from the mains distribution switchboard.

- STEP 3 Ensure that the Lithium battery is fitted to battery holder on the CPU card,
and link P3 is fitted to the BAT ON position.

 Turn the Mains Isolate Switch ON.

- STEP 4 Check that the green "MAINS ON" LED indicator is on.
 The Controller performs tests on its memory, electronics, and the LCD.

- STEP 5 Check that the buzzer sounds and the LCD display "CPU Serial Number".

- STEP 6 Check that the LCD has good visibility.

- STEP 7 Install and connect the batteries.
 Take care not to short the battery leads or connect in reverse polarity when connecting.

- STEP 8 Press the Lamp Test key on the Operator I/F and check that all LEDs turn
on, and the LCD shows all black squares.

- STEP 9 Clear all faults one at a time.

A full commissioning test should be carried out as per AS1670.1. Refer to the appendix in this manual for detail on checking wiring, and earth fault detection. Refer to the Operator's Manual LT0351 for detail of the walk test that may be used for verifying correct detector operation.

Maintenance

The 4100U system must be kept free from faults and tested on a weekly, monthly and annual basis to verify that it is operating correctly. The tests required by part 8 of the standard AS1851 Maintenance of Fire Protection Equipment are detailed in the 4100U Operator's Manual, LT0351.

The Operator's manual also provides detail of report printing and performing tests that are useful for checking the system.

Appendix A

The Device Configuration DIP Switch

Overview

Addressable cards include a bank of eight DIP switches. From left to right (see Figure A-1, below) these switches are designated as SW_x-1 through SW_x-8. The function of these switches is as follows:

- **SW_x-1.** This switch sets the baud rate for the internal 4100 communications line running between the card and the CPU. Set this switch to ON.
- **SW_x-2 through SW_x-8.** These switches set the card's address within the 4100 FACP. Refer to Table A-1 for a complete list of the switch settings for all of the possible card addresses.

Note: You must set these switches to the value assigned to the card by the 4100 Programmer.

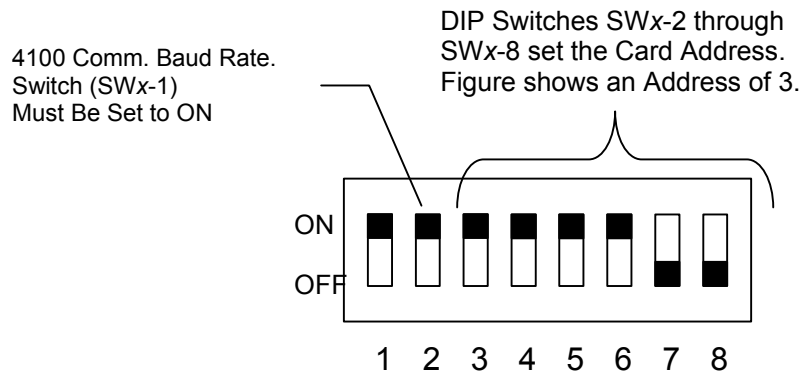

Figure A-1. DIP Switch SW_x

Continued on next page

Overview,
(continued)

Table A-1. Card Addresses

Address	SW 1-2	SW 1-3	SW 1-4	SW 1-5	SW 1-6	SW 1-7	SW 1-8	Address	SW 1-2	SW 1-3	SW 1-4	SW 1-5	SW 1-6	SW 1-7	SW 1-8
1	ON	ON	ON	ON	ON	ON	OFF	61	ON	OFF	OFF	OFF	OFF	ON	OFF
2	ON	ON	ON	ON	ON	OFF	ON	62	ON	OFF	OFF	OFF	OFF	OFF	ON
3	ON	ON	ON	ON	ON	OFF	OFF	63	ON	OFF	OFF	OFF	OFF	OFF	OFF
4	ON	ON	ON	ON	OFF	ON	ON	64	OFF	ON	ON	ON	ON	ON	ON
5	ON	ON	ON	ON	OFF	ON	OFF	65	OFF	ON	ON	ON	ON	ON	OFF
6	ON	ON	ON	ON	OFF	OFF	ON	66	OFF	ON	ON	ON	ON	OFF	ON
7	ON	ON	ON	ON	OFF	OFF	OFF	67	OFF	ON	ON	ON	ON	OFF	OFF
8	ON	ON	ON	OFF	ON	ON	ON	68	OFF	ON	ON	ON	OFF	ON	ON
9	ON	ON	ON	OFF	ON	ON	OFF	69	OFF	ON	ON	ON	OFF	ON	OFF
10	ON	ON	ON	OFF	ON	OFF	ON	70	OFF	ON	ON	ON	OFF	OFF	ON
11	ON	ON	ON	OFF	ON	OFF	OFF	71	OFF	ON	ON	ON	OFF	OFF	OFF
12	ON	ON	ON	OFF	OFF	ON	ON	72	OFF	ON	ON	OFF	ON	ON	ON
13	ON	ON	ON	OFF	OFF	ON	OFF	73	OFF	ON	ON	OFF	ON	ON	OFF
14	ON	ON	ON	OFF	OFF	OFF	ON	74	OFF	ON	ON	OFF	ON	OFF	ON
15	ON	ON	ON	OFF	OFF	OFF	OFF	75	OFF	ON	ON	OFF	ON	OFF	OFF
16	ON	ON	OFF	ON	ON	ON	ON	76	OFF	ON	ON	OFF	OFF	ON	ON
17	ON	ON	OFF	ON	ON	ON	OFF	77	OFF	ON	ON	OFF	OFF	ON	OFF
18	ON	ON	OFF	ON	ON	OFF	ON	78	OFF	ON	ON	OFF	OFF	OFF	ON
19	ON	ON	OFF	ON	ON	OFF	OFF	79	OFF	ON	ON	OFF	OFF	OFF	OFF
20	ON	ON	OFF	ON	OFF	ON	ON	80	OFF	ON	OFF	ON	ON	ON	ON
21	ON	ON	OFF	ON	OFF	ON	OFF	81	OFF	ON	OFF	ON	ON	ON	OFF
22	ON	ON	OFF	ON	OFF	OFF	ON	82	OFF	ON	OFF	ON	ON	OFF	ON
23	ON	ON	OFF	ON	OFF	OFF	OFF	83	OFF	ON	OFF	ON	ON	OFF	OFF
24	ON	ON	OFF	OFF	ON	ON	ON	84	OFF	ON	OFF	ON	OFF	ON	ON
25	ON	ON	OFF	OFF	ON	ON	OFF	85	OFF	ON	OFF	ON	OFF	ON	OFF
26	ON	ON	OFF	OFF	ON	OFF	ON	86	OFF	ON	OFF	ON	OFF	OFF	ON
27	ON	ON	OFF	OFF	ON	OFF	OFF	87	OFF	ON	OFF	ON	OFF	OFF	OFF
28	ON	ON	OFF	OFF	OFF	ON	ON	88	OFF	ON	OFF	OFF	ON	ON	ON
29	ON	ON	OFF	OFF	OFF	ON	OFF	89	OFF	ON	OFF	OFF	ON	ON	OFF
30	ON	ON	OFF	OFF	OFF	OFF	ON	90	OFF	ON	OFF	OFF	ON	OFF	ON
31	ON	ON	OFF	OFF	OFF	OFF	OFF	91	OFF	ON	OFF	OFF	ON	OFF	OFF
32	ON	OFF	ON	ON	ON	ON	ON	92	OFF	ON	OFF	OFF	OFF	ON	ON
33	ON	OFF	ON	ON	ON	ON	OFF	93	OFF	ON	OFF	OFF	OFF	ON	OFF
34	ON	OFF	ON	ON	ON	OFF	ON	94	OFF	ON	OFF	OFF	OFF	OFF	ON
35	ON	OFF	ON	ON	ON	OFF	OFF	95	OFF	ON	OFF	OFF	OFF	OFF	OFF
36	ON	OFF	ON	ON	OFF	ON	ON	96	OFF	OFF	ON	ON	ON	ON	ON
37	ON	OFF	ON	ON	OFF	ON	OFF	97	OFF	OFF	ON	ON	ON	ON	OFF
38	ON	OFF	ON	ON	OFF	OFF	ON	98	OFF	OFF	ON	ON	ON	OFF	ON
39	ON	OFF	ON	ON	OFF	OFF	OFF	99	OFF	OFF	ON	ON	ON	OFF	OFF
40	ON	OFF	ON	OFF	ON	ON	ON	100	OFF	OFF	ON	ON	OFF	ON	ON
41	ON	OFF	ON	OFF	ON	ON	OFF	101	OFF	OFF	ON	ON	OFF	ON	OFF
42	ON	OFF	ON	OFF	ON	OFF	ON	102	OFF	OFF	ON	ON	OFF	OFF	ON
43	ON	OFF	ON	OFF	ON	OFF	OFF	103	OFF	OFF	ON	ON	OFF	OFF	OFF
44	ON	OFF	ON	OFF	OFF	ON	ON	104	OFF	OFF	ON	OFF	ON	ON	ON
45	ON	OFF	ON	OFF	OFF	ON	OFF	105	OFF	OFF	ON	OFF	ON	ON	OFF
46	ON	OFF	ON	OFF	OFF	OFF	ON	106	OFF	OFF	ON	OFF	ON	OFF	ON
47	ON	OFF	ON	OFF	OFF	OFF	OFF	107	OFF	OFF	ON	OFF	ON	OFF	OFF
48	ON	OFF	OFF	ON	ON	ON	ON	108	OFF	OFF	ON	OFF	OFF	ON	ON
49	ON	OFF	OFF	ON	ON	ON	OFF	109	OFF	OFF	ON	OFF	OFF	ON	OFF
50	ON	OFF	OFF	ON	ON	OFF	ON	110	OFF	OFF	ON	OFF	OFF	OFF	ON
51	ON	OFF	OFF	ON	ON	OFF	OFF	111	OFF	OFF	ON	OFF	OFF	OFF	OFF
52	ON	OFF	OFF	ON	OFF	ON	ON	112	OFF	OFF	OFF	ON	ON	ON	ON
53	ON	OFF	OFF	ON	OFF	ON	OFF	113	OFF	OFF	OFF	ON	ON	ON	OFF
54	ON	OFF	OFF	ON	OFF	OFF	ON	114	OFF	OFF	OFF	ON	ON	OFF	ON
55	ON	OFF	OFF	ON	OFF	OFF	OFF	115	OFF	OFF	OFF	ON	ON	OFF	OFF
56	ON	OFF	OFF	OFF	ON	ON	ON	116	OFF	OFF	OFF	ON	OFF	ON	ON
57	ON	OFF	OFF	OFF	ON	ON	OFF	117	OFF	OFF	OFF	ON	OFF	ON	OFF
58	ON	OFF	OFF	OFF	ON	OFF	ON	118	OFF	OFF	OFF	ON	OFF	OFF	ON
59	ON	OFF	OFF	OFF	ON	OFF	OFF	119	OFF	OFF	OFF	ON	OFF	OFF	OFF
60	ON	OFF	OFF	OFF	OFF	ON	ON								

Appendix B

Programming Requirements

Introduction

This appendix identifies the programming that is required to comply with AS4428.

It does not provide equations or detail of programming. The separate 4100 Programming Unit Manual tells how to use the PC-based 4100U Programmer.

In this Chapter

Refer to the page number listed in this table for information on a specific topic.

Topic	See Page #
Required Features	B-1

Required Features

The following is a list of functions that must be programmed under custom control. Refer to Fig 2-7. Functionality must comply with AS4428.1, and be as described in the Operator's manual LT0351.

- Individual zone alarm indication, flashing until isolated, steady when isolated.
 - Common Zone Alarm indication, flashing when any zone in alarm is un-isolated, steady when all zones in alarm are isolated.
 - Individual zone isolate pushbutton and indication.
 - Zone Alarm Test pushbutton and indication.
 - Zone Fault Test pushbutton and indication.
 - Warning System Isolate pushbutton and indication.
 - Ancillary Control Function and Isolate pushbutton and indication as required.
 - Weekly 1 hour battery test.
 - Fault indication after 8 hours of isolate.
-

Notes

- The panel format is different to that on the programmer because the CPU card is fitted on the rhs of the first expansion bay, and extra cards may be fitted to the left of it.
 - The US options for power supply and AVF are selected, not the Canadian ones.
 - Features that do not comply with AS4428 must not be enabled, e.g. Alarm cut-out times.
 - Features that are statutory in AS4428 must not be pass-code protected, e.g. zone isolate, zone test (Fault and Alarm).
-

Appendix C

Checking System Wiring

Overview

This appendix contains instructions on how to use a volt/ohm meter to check system wiring.

Using the Volt/Ohm Meter

When using the volt/ohm meter to check each circuit, make sure to adhere to the notes and instructions below.

Notes:

- Ensure that no power is applied to the 4100U fire alarm panel and that all wiring is properly connected (terminal blocks, LED/switch module ribbon cables, etc.).
- Use the earth stud in the control panel for all measurements to ground.
- Each circuit must test free of all grounds and extraneous voltages.

Use the volt/ohm meter as described in the steps below to check each circuit type.

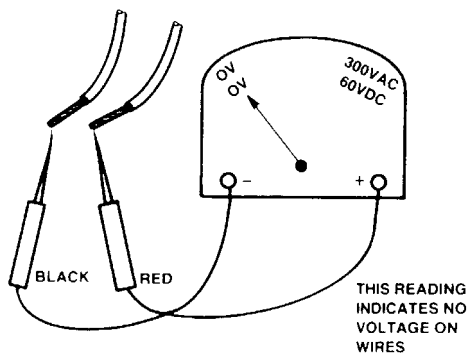

A. No Voltage

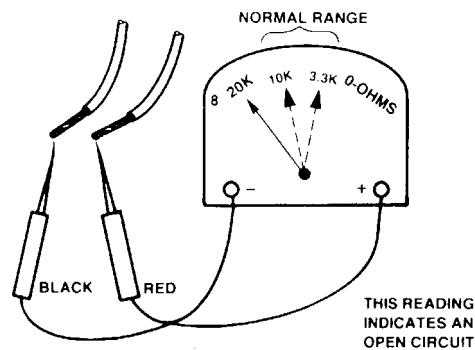

B. Open Circuit

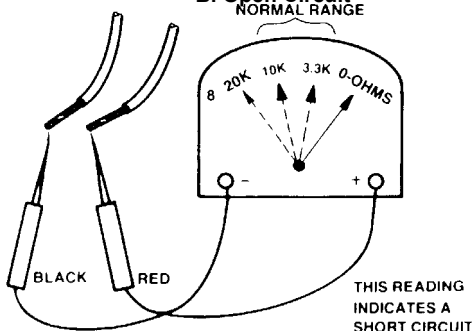

1. At the control panel, locate wires from each initiating device or indicating appliance circuit.
2. Check each circuit for extraneous voltage by setting the volt/ohm meter to 300 VAC. Place the meter probes so that the black probe is on the “-” wire and the red probe is on the “+” wire. Meter readings must show 0 volts (see Figure D-1A).
3. Set the volt/ohm meter to 60 VDC and repeat step 2. The meter must read 0 volts (see Figure D-1A).
4. Set the volt/ohm meter to OHMS x 10 and place the meter probes as described in step 2. Check the circuits using the resistance measurements in Table D-1. Locate and correct any abnormal conditions at this time. **Note:** If the reading indicates an open circuit in an initiating circuit, make sure the smoke detector heads are properly mounted and seated. The circuit may be open if smoke detector power is not present, and if separately powered 4-wire devices are used.
5. Check all other system wiring to verify that each circuit is free of grounds and extraneous voltages.

C. Short Circuit

Figure D-1. Volt/Ohm Meter Readings

Continued on next page

Appendix C: Checking System Wiring, *Continued*

Meter Readings

Table C-1 lists the correct meter readings for indicating appliances and initiating devices.

Table C-1. Acceptable Zone and Signal Circuit Meter Readings

Circuit Type	Meter Reading
Class B/Style B Initiating Device (Zone) Circuit	
From zone + to zone – (each zone)	3.3 K Ohms
From zone + to ground	Infinity
From zone - to ground	Infinity
Class A/Style D Initiating Device (Zone) Circuit	
From zone + to zone – (each zone)	Infinity
From zone + to ground	Infinity
From zone - to ground	Infinity
From zone + OUT to + IN	Less than 50 Ohms
From zone - OUT to - IN	Less than 50 Ohms
Class B/Style Y Notification Appliance Circuit (each signal circuit)	
From + to ground	Infinity
From - to ground	Infinity
Resistance across circuit: In one direction In opposite direction	10 K Ohms Less than 200 Ohms
Class A/Style Z Notification Appliance Circuit (each signal circuit)	
From + to ground	Infinity
From - to ground	Infinity
From zone + OUT to + IN	Less than 50 Ohms
From zone - OUT to - IN	Less than 50 Ohms
Resistance across circuit: In one direction In opposite direction	Infinity Less than 200 Ohms
Shielding	
Shield to ground	Infinity
Shield to -	Infinity
Shield to +	Infinity
MAPNET/IDNet II Loops (ZAMs and IAMs)	
From MAPNET/IDNet II + to ground	Infinity
From MAPNET/IDNet II - to ground	Infinity

Appendix D

Earth Fault Detection

Overview

This appendix contains instructions on how to use the Earth Fault Search feature of the 4100U diagnostics menus.

Earth Fault Search is a diagnostic search of external field wiring that assists in locating circuits with earth faults. An earth fault occurs when an electrical circuit is shorted to ground. Although most circuits operate with a single earth fault, multiple earth faults can disable communications. Because of this, earth faults must be located and repaired.

Earth Fault Search is conducted by the FACP. The diagnostic may be activated using either the front panel interface or the Computer Port Protocol (CPP), via a service port.

The 4100U supports two types of Earth Fault Searches:

- **Location Search.** Searches all circuits at a location, such as a transponder or the main panel. For the purposes of Earth Fault Searching,
 - A *location* is composed of a group of slaves connected to each other via 4100 Comm (local RUI).
 - The *main panel* is defined as all slaves local to the Master CPU.
 - A *transponder* denotes all slaves associated with a single Transponder Interface Card (TIC)/Local Mode TIC slave.
 - **IDNet Channel Search.** Selectively enables channel isolators and repeaters to detect which segment of the channel wiring has a fault.
 - Earth faults are detected by one of the following:
 - A single designated power supply at a location. The power supply that detects the fault is designated via a jumper setting on the power supply slave. For any given location, only one power supply should detect earth faults.
 - Each 4009 IDNet NAC Extender on an IDNet channel.
-

General Guidelines

Review the guidelines below before initiating an Earth Fault Search.

- The Detect Earth Fault jumper must be installed at each SPS, RPS, TPS, IPS, or 4009T for earth fault detection to occur.
- Only one power supply per location is configured to detect earth faults.
- For more reliable earth fault searching:
 - Use a Firefighter Telephone NAC for each telephone riser connection to a transponder.
 - Use IDNet channel isolators to isolate channel faults to a specific segment of channel wiring.
 - Set IDNet channel isolator addresses to the lowest IDNet device addresses, increasing with communication distance from the IDNet card.
- If an earth fault is suspected on the IDNet channel with multiple isolators, start an IDNet Channel Search before doing a Location Search. If the Location Search is done first, it may not yield the correct location (this is a by-product of the extended amount of time required for the IDNet channel to initialize during a Location Search). *Note:* The 4009 IDNet NAC Extender has a common ground fault trouble that reports to the panel without running the Earth Fault Search.
- Earth Fault Search detects only one fault at a time. Multiple faults require fixing the first fault and then repeating the search.
- The FACP suspends normal operation for the duration of the Earth Fault Search.
- Location Earth Fault Searches optionally allow exclusion of auxiliary power circuits from the search, so that modules connected to the 24 V auxiliary outputs can remain in operation during the search.
- The option to exclude auxiliary power circuits does not apply to IDNet devices, because the entire IDNet communication channel is isolated during each search.
- During the search, all related troubles are suppressed and a single trouble pseudo-point is activated (P438).
- At the completion of the search, all slaves are restarted and normal panel operation resumes.
- Earth Fault Search is only supported by new 4100U modules. 4100 Legacy (slot format) modules are not supported, with the following exceptions:
 - MAPNET channel isolation during location search
 - IPS for earth fault detection (not recommended). The Earth Fault Search may fail because the isolation circuits of some 4100U slaves (such as the 4100U telephone slave) do not support IPS.

IMPORTANT: The fire panel cannot provide fire protection during an Earth Fault Search.

Earth Fault Searching from the Front Panel

Overview

This section describes how to conduct an Earth Fault Search, from selecting the appropriate access code to correcting the fault.

Access Level Selection

The panel must be at the appropriate access level (1, 2, 3, or 4) in order to run diagnostics. To get to the correct access level,

1. Press the Menu button. The following message comes up (press the Next or Previous buttons, if necessary, to display it):

```
Press <NEXT> or <PREVIOUS> to scroll  
Change Access Level?
```

3. Press the Enter button. Now you are prompted to log in or log out.

```
1=Login 2=Logout  
CURRENT ACCESS LEVEL = x
```

4. Press the "1" key on the numeric keypad to log in, so that the passcode prompt comes up.

```
Enter a Passcode followed by <ENTER>
```

5. Enter the passcode and press the Enter button. ACCESS GRANTED displays briefly on the LCD, and then the display goes back to:

```
1=Login 2=Logout  
CURRENT ACCESS LEVEL = y
```

You can now open the diagnostic menu as described in the next topic.

Starting the Earth Fault Search

To start an Earth Fault Search,

1. If necessary, press the Menu button to access the menus.
6. Press the Previous or Next buttons until the diagnostic functions option appears:

```
Press <NEXT> or <PREVIOUS> to scroll  
Diagnostic Functions?
```

7. Press the Enter button. Then press Next or Previous buttons until the Earth Fault Search option appears:

```
Press <NEXT> or <PREVIOUS> to scroll  
Earth Fault Search?
```

Continued on next page

Earth Fault Searching from the Front Panel, *Continued*

Starting the Earth Fault Search, Continued

8. Press the Enter button. The following options become available when you press the Next and Previous buttons:

Press <NEXT> or <PREVIOUS> to scroll Location Search
Press <NEXT> or <PREVIOUS> to scroll IDNet Channel Search
Press <NEXT> or <PREVIOUS> to scroll Last Search Result

The search types are described below. When you have determined what kind of search to initiate, display its option (one of the three shown above) and press the Enter button. Each option has its own topic, below.

Search Option A: Select Location

If you select the Location Search menu item, a list of cards to search becomes available. Use the Next and Previous buttons to scroll through the list.

If you find a card that you suspect is connected to a circuit with an earth ground, press the Enter button when that circuit is shown.

Before you can start the search, the Aux Power Select option comes up.

1=Exclude 2=Include Exclude AUXPWR circuits from search?
--

The number you select, 1 or 2, determines whether the auxiliary power circuit on the selected board is searched for earth grounds. If you exclude the auxiliary power circuit from the search, the circuit will continue to operate normally.

Press 1 (or just press the Enter button) to exclude the card's auxiliary power circuits from the search, or press 2 to remove auxiliary power circuits from normal operation and search them for earth grounds.

Now you are prompted to start the search. When the location you want to search is shown and "Press <ENTER> to start search" displays, the search is ready to start. A sample is shown below.

CARD 1, SYSTEM POWER SUPPLY Press <ENTER> to start search
--

NOTE: The FACP suspends normal operation for the duration of the search.

Press the Enter button to start the search.

As the search progresses, watch the display for an indication of how much of the search has been completed. The search can be aborted at any time if you press the Clear button.

Earth Search In-Progress, Please Wait...
--

Earth Search In-Progress, Please Wait... 40%

Skip ahead to the "Completing the Search" topic.

Continued on next page

Earth Fault Searching from the Front Panel, *Continued*

Search Option B: Select Channel

If you select the IDNet Channel Search menu item, a list of IDNet channels to search becomes available. Use the Next and Previous buttons to scroll through the list. When the IDNet channel you want to search is shown and "Press <ENTER> to start search" displays, the search is ready to start. A sample screen is shown below.

```
IDNET CHANNEL M12
Press <ENTER> to select for search
```

NOTE: The FACP suspends normal operation for the duration of the search.

Press the Enter button to start the search.

As the search progresses, watch the display for an indication of how much of the search has been completed. The search can be aborted at any time if you press the Clear button.

```
Earth Search In-Progress, Please Wait...
```

```
Earth Search In-Progress, Please Wait...
                               40%
```

Skip ahead to the "Completing the Search" topic.

Search Option C: Last Search Result

This option simply displays the last Earth Fault Search result. If there has been no search since the last system startup, or if the last search was aborted, the panel displays "RESULT NOT AVAILABLE."

Completing the Search

When a Location or IDNet Channel Search completes, all of the following occurs:

- All slaves automatically reset.
- The FACP turns off the Earth Fault Search trouble pseudo-point.
- The panel displays the specific fault information.

The panel can only return one Earth Fault Search result at a time. If another fault exists, it can only be found via diagnostics after the first fault is cleared. Faults will continue to appear, one by one, until each one has been found and corrected.

IMPORTANT: Once you have been directed to an earth ground fault and corrected it, it is recommended that you restart the system (warm- or cold-start).

Continue to the next topic for a list of search results and their required actions.

Search Results

Overview

There are several types of results that can display at the end of an Earth Fault Search. This section covers all types of results.

IMPORTANT: Once you have been directed to an earth ground fault and corrected it, it is recommended that you restart the system (warm- or cold-start).

Non-Point Faults

A non-point fault indicates a ground that cannot be traced to an addressable point (for example, a shield or an audio riser). The earth fault in this example is not occurring at the audio controller but somewhere in the riser:

```
CARD 17, ANALOG AUDIO CONTROLLER
AUDIO RISER 1 EARTH FAULT
```

Non-point faults can be displayed for each of the following items:

- Shield (Flex 50/100 W Amplifier)
 - Audio Riser (Digital./Analog Audio Controller; Local Mode Transponder; may also announce as "DAR SECONDARY" (Digital Audio Riser Secondary) on transponder)
 - Remote Mic 1 and Push-to-Talk line (Digital./Analog Audio Controller) (other remote mics are not supported)
 - Channel Output (IDNet Card; MAPNET Interface Card)
 - RUI Channel (Master Controller Card)
 - Channel 1 to 3 (TrueAlert Power Supply)
-

Point Faults

A point fault indicates a ground at a specific addressable point. The example below is a location earth ground search result, where 3 is the card address, 10 is the point number, and 0 is the sub-point number (not used):

```
CARD 003, FLEX 50 AMPLIFIER
3-10-0 EARTH FAULT
```

Point faults can be found at any point in the system that connects to field wiring.

Some IDNet channel point fault examples are illustrated below.

Fault not cleared. The message below shows that an IDNet channel that has been isolated for fault detection still has the earth fault:

```
CARD 2, IDNET CARD (250 POINTS)
M1, EARTH FAULT SEARCH FAULT CLEAR FAIL
```

Fault between channel output and first isolator. The message below shows a fault between the IDNet channel output and the first isolator on the line:

```
CARD 2, IDNET CARD (250 POINTS)
M1, CHANNEL OUTPUT EARTH FAULT
```

Continued on next page

Search Results, *Continued*

Point Faults, Continued

4009 IDNet NAC Extender/TrueAlert Addressable Controller faults. The message below shows a fault detected on the 4009 IDNet NAC Extender **before** the repeater connected to that circuit is turned on:

```
CARD 2, IDNET CARD (250 POINTS)
M1-18, 4009A NAC EARTH FAULT
```

Conversely, the following example shows a fault detected **after** the repeater connected to that circuit is turned on:

```
CARD 2, IDNET CARD (250 POINTS)
M1-18, 4009A REPEATER EARTH FAULT
```

IDNet isolator fault. The message below shows a fault detected after the IDNet isolator was turned on:

```
CARD 2, IDNET CARD (250 POINTS)
M1-3, IDNET ISOLATOR EARTH FAULT
```

Fault Not Found

If the message in the lower right corner of the LCD reads FAULT NOT FOUND (for a Location Earth Fault Search) or FAULT CLEAR FAIL (for an IDNet Channel Earth Fault Search), it means the search could not locate the fault, but it acknowledges that a fault exists.

There are three main possibilities behind this message:

- There are one or more internal wiring earth(s) in the system.
- There are system defects (hardware or software, such as a failed isolation circuit).
- An intermittent earth exists in the system (it occurs inconsistently and is therefore difficult to track via diagnostics).
- The cable to the service port may be grounded due to the remote PC's 3-prong plug. Use a non-grounded plug adapter to the remote PC to get rid of the earth ground.
- The fault is on an auxiliary output that was excluded from the search.

The problem may have to be found manually and then corrected in some of the above scenarios.

No Fault

If the message in the lower right corner of the LCD reads NO FAULT, it means the IDNet channel search could not locate any earth faults on that channel.

Result Not Available

If the message in the lower right corner of the LCD reads RESULT NOT AVAILABLE, it means there is no result to view. This message comes up only when you have selected "Last Search Result" on the menu.

Earth Fault Search Example

The illustration below shows a MINIPLEX system with one transponder that has three earth faults:

- SPS NAC on the SPS in the Main Panel
- RPS AUXPWR output on the RPS in Transponder 1
- IDNet channel in Transponder 1

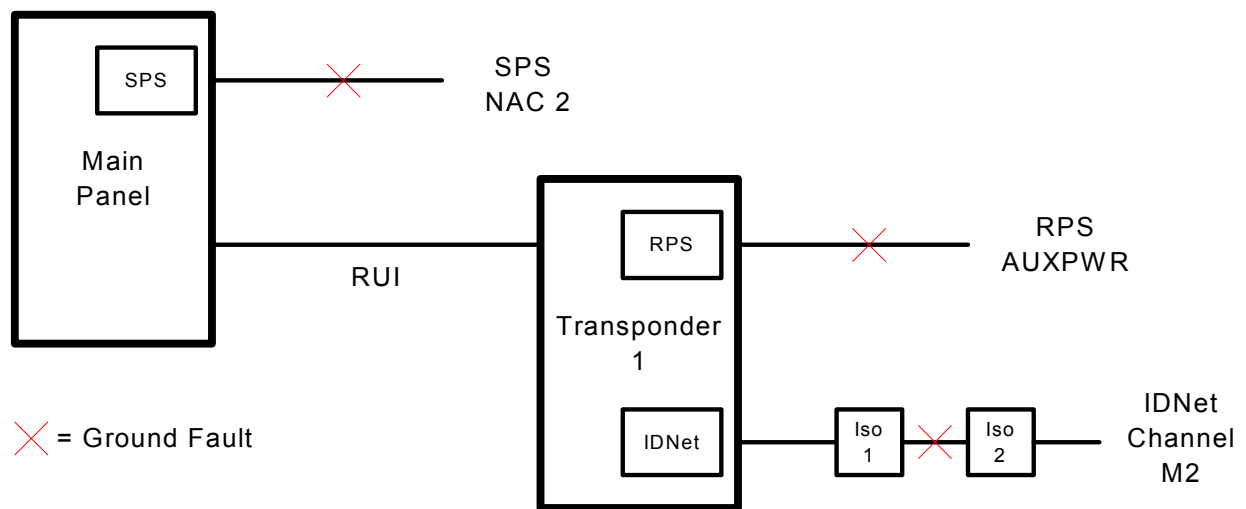

Figure F-1. Earth Fault Example

The panel reports two earth faults—one for each power supply. The third fault is as yet unreported.

The example below shows the progression of events in finding and repairing the three faults. They are presented as instructions to a technician who does not yet know about the third fault.

A. Find and repair the fault in the main panel.

1. After opening the Earth Fault Search diagnostic menu option, select Location Search.
9. Select the SPS located in the Main Panel (this selects the Main Panel as the location for the search).
10. When prompted, select exclusion of AUXPWR circuits.
11. Start the search. (The panel turns on the earth fault search trouble pseudo-point and the keypad inactivity utility pseudo-point to disable timeout during the search).
12. The search completes. The panel indicates that NAC 2 on the SPS has the earth fault. All slaves are reset (and the panel turns off the earth fault search trouble pseudo-point).
13. Repair the earth fault on NAC 2. When this is done, the trouble from the SPS clears but the trouble from the RPS is still indicated.

Continued on next page

Search Results, *Continued*

B. Find and repair the indicated fault on Transponder 1.

1. Select Location Search.
14. Select the RPS located in Transponder 1 (this selects Transponder 1 as the location for the search).
15. When prompted, select exclusion of AUXPWR circuits.
16. Start the search. (The panel turns on the earth fault search trouble pseudo-point and the keypad inactivity utility pseudo-point to disable timeout during the search).
17. The search completes. The panel indicates FAULT NOT FOUND because the fault is on the excluded AUXPWR circuit. All slaves in Transponder 1 are reset (and the panel turns off the earth fault search trouble pseudo-point).
18. Repeat the search but include the AUXPWR circuit this time.
19. The search completes. The panel indicates a fault on the AUXPWR point on the RPS. All slaves in Transponder 1 are reset (and the panel turns off the earth fault search trouble pseudo-point).
20. Repair the earth fault on AUXPWR.

Even though you have fixed the fault, the trouble from the RPS is still not clearing. Remember that the only two faults you could see at first were from the SPS and RPS. It is time to find and clear the next fault.

C. Find and repair the next indicated fault on Transponder 1.

1. Select Location Search.
 21. Select the RPS located in Transponder 1.
 22. When prompted, select exclusion of AUXPWR circuits.
 23. Start the search.
 24. The search completes. The panel indicates a fault on IDNet Channel M2.
 25. Start another search, this time an IDNet Channel Search on Channel M2.
 26. When prompted, select exclusion of AUXPWR circuits.
 27. The search completes. The panel indicates a fault on the IDNet channel between isolators 1 and 2.
 28. Repair the earth fault. The trouble from the RPS is cleared.
-

Appendix E

Related Documentation

The following manuals are relevant. Other Australian 4100 manuals may be found on the TSP website.

Book Part Number	Title
LT0293	4100A FIP AS4428 Operators Manual
LT0294	4100A FIP AS4428 Installation Manual
LT0295	4100A FIP AS4428 Technical Manual
LT0307	4100 Field Wiring Diagrams
LT0313	4100 MXP Engineering/Technical Manual
LT0314	4100 MXP Installation Instructions
LT0351	4100U Operators Manual (For ordering, LT0351 is A5, LT0351A4 is A4.)

The following is a complete listing of US 4100U documentation.

Book Part Number	Title
574-037	4100/4120-0136 and 4100-6045 Decoder Modules Installation Instructions
574-046	4100/4120-0139 Dial-Up Service Modem Installation Instructions
574-197	4100U Fire Alarm Operator's Manual
574-674	4100/4120-Series MAPNET Isolator Modules Installation Instructions
574-772	4100U XPS and XNAC Installation Instructions
574-800	4100U IDNet Cards Installation Instructions
574-836	4100/4120-Series Event and Point Reporting Digital Alarm Communications Transmitters (DACTs) Installation Instructions
574-839	4100U City and Relay Cards Installation Instructions
574-844	4100U Communication and Audio Interface Modules Installation Instructions
574-848	4100U Fire Alarm System/ System Installation Guide

Continued on next page

Appendix E: Related Documentation, *Continued*

Book Part Number (cont.)	Title (cont.)
574-849	4100U PC Programmer Programming Manual
575-978	4100/4120 Battery Cabinet Installation Instructions
579-117	4100U Back Boxes and Accessories Installation Instructions
579-159	4100U Digital/Analog Audio Controllers Installation Instructions
579-160	4100U Audio Input Card Installation Instructions
579-168	4100U Audio Operator Interface Installation Instructions
579-172	4100U Message Memory Expansion Cards Installation Instructions
579-173	4100U Flex Amplifiers Installation Instructions
579-174	4100U Digital/Analog Amplifiers Installation Instructions
579-175	4100U Class A and Expansion NAC Modules Installation Instructions
579-182	4100/4120-Series NIC and Media Modules Installation Instructions
579-184	4100/4120-Series Physical Bridges and 4100/4120-Series Media Modules Installation Instructions
579-194	4100-6030 Service Modem Installation Instructions
579-195	4100U Tamper Switch Installation Instructions
579-205	4100/4120-Series Class A / Class B Zone Modules Installation Instructions
579-220	4100/4120-Series Relay Modules Installation Instructions
579-221	4100/4120-Series Dual RS-232/2120 Modules Installation Instructions
579-222	4100/4120-Series MAPNET II Transceivers Installation Instructions
579-223	4100/4120-Series Class A / Class B NAC Modules Installation Instructions

Continued on next page

Appendix E: Related Documentation, *Continued*

Book Part Number (cont.)	Title (cont.)
579-175	4100U Class A and Expansion NAC Modules Installation Instructions
579-229	4100U Upgrade Kits Installation Instructions
579-246	4100U SPS/RPS Installation Instructions
579-248	4100-0632 Terminal Block Utility Module Installation Instructions
579-331	4100U Redundant Master Controller Installation Instructions
579-347	4100U Fire Alarm System Placement Guidelines
579-515	4100U Constant Supervision NAC (CSNAC) Modules Installation Instructions
579-516	4100U Expansion Signal (XSIG) Card Installation Instructions
579-571	4100-1265 DFSM (Degraded Fail-Safe Mode) Microphone Preamp Card Installation Instructions
579-575	4100U TFX Interface Installation Instructions

Appendix F

Compatible Actuating Devices

Introduction

This appendix describes the following:

- It lists devices that have been approved as compatible devices for use with the 4100A/4100U FIP.
 - It lists the devices approved for use with the IDNet and shows the number allowed per loop.
-

In this Chapter

Refer to the page number listed in this table for information on a specific topic.

Topic	See Page #
List of Approved Devices	F-1
Compatible Detectors, IDNET	F-4
Compatible Addressable Field Devices, IDNet	F-5

List of Approved Devices

Simplex Range - Conventional Detectors

4098-9413	Heat detector Type A
4098-9414	Heat detector Type B
4098-9415	Heat detector Type C
4098-9416	Heat detector Type D
2098-9201	Photoelectric smoke detector
2098-9576	Ionisation smoke detector
4098-9618EA	Heat detector Type A
4098-9619EA	Heat detector Type B
4098-9621EA	Heat detector Type D
4098-9621A	Heat detector Type C
4098-9601EA	Photoelectric smoke detector
4098-9603EA	Ionisation smoke detector

Continued on next page

List of Approved Devices, *Continued*

Hochiki Range - Conventional Detectors

DCA-B-60R MK V	Type A heat detector
DCC-A	Heat Type A
DCC-C	Heat Type C
DCD-A	Heat Type A
DCD-C	Heat Type C
DFE-60B	Type B heat detector
DCA-B-90R MK 1	Type C heat detector
DFE-90D	Type D heat detector
DFG-60BLKJ	Type B heat detector
DFJ-60B	Heat Type B
DFJ-90D	Heat Type D
SPA-AB	Beam type smoke detector
SIH-AM	Ionisation smoke detector
SIF-A MK 1	Smoke
SIJ-ASN	Smoke
SLK-A	Photoelectric smoke detector
SLG-A MK 1	Smoke
SLG-AM MK 1	Photoelectric smoke detector
SLR-AS	Smoke
HF-24A MK 1	Ultraviolet smoke detector
YBC-R/3A	Plain - non indicating base
YBF-RL/4AH4	LED Indicating base

Olsen Range - Conventional Detectors

B111B	Beam type smoke detector
C24B	Ionisation smoke detector
C29BEX	Ionisation smoke detector
FW81B	Heat detector cable, Type E
P24B	Photoelectric smoke detector
P29B	Photoelectric smoke detector
R23B	Infrared flame detector
R24BEX	Dual spectrum infrared flame detector
T54B	Probe type heat detector type E
T56B	Heat detector types A,B,C,D with Z55B base
T56B	Heat detector types A,B,C,D with Z54B base
V41B/V42B	Ultraviolet flame detector

Apollo Range - Conventional Detectors

Series 60 Heat detector Type A
Series 60 Heat detector Type B
Series 60 Heat detector Type C
Series 60 Heat detector Type D
Series 60 55000-310 Aus Photoelectric smoke detector
Series 60 55000-240 Aus Ionisation smoke detector

Continued on next page

List of Approved Devices, *Continued*

Brooks Range - Conventional Detectors

PFS-A	Heat detector Type A
PFS-B	Heat detector Type B
PFS-C	Heat detector Type C
PFS-D	Heat detector Type D
PFS-P	Photoelectric smoke detector
PFS-P MK II	Photoelectric smoke detector
PFS-I	Ionisation smoke detector
PFS-I MK II	Ionisation smoke detector

Cerberus Range - Conventional Detectors

D01191A	Beam
DL01191A	Beam

The following range of detectors may be used with MAPNET Modules.

Simplex Range - Analog Addressable Sensors

4098-9701	High / Very High sensitivity Photoelectric smoke
4098-9716	Ionisation smoke
4098-9731	Type A / Type B Heat
4098-9781	Addressable LED Indicating base
4098-9782	Addressable LED Indicating base with Sounder
4098-9783	Addressable LED Indicating base with Relay
driver	
4098-9714/9714EA	TrueAlarm Photoelectric smoke
4098-9717/9717EA	TrueAlarm Ionization smoke
4098-9733/9733EA	TrueAlarm Type A / Type B Heat
4098-9754/9754EA	TrueAlarm Multi-Sensor Photo / Type A / Type B
Heat	
4098-9789/9789EA	TrueAlarm Addressable LED Indicating base
4098-9794/9794EA	TrueAlarm Addressable LED Indicating base
	with Sounder
4098-9795/9795EA	TrueAlarm Addressable Multi-Sensor LED
	Indicating base with Sounder
4098-9796/9796EA	TrueAlarm Addressable Multi-Sensor LED
	Indicating base
4098-9752/9752EA	TrueAlarm Addressable Photoelectric Duct
	Probe
4098-9755/9755EA	TrueAlarm Addressable Photoelectric Duct
	Probe

Continued on next page

List of Approved Devices, *Continued*

Simplex MAPNET 2 Range – Addressable Field Devices

2190-9156	Mapnet 2 Monitor ZAM
2190-9162	Mapnet 2 Signal ZAM
2190-9164	Mapnet 2 Control ZAM
2190-9169	Mapnet 2 Line Powered Short Circuit Isolator
2190-9172	Mapnet 2 Supervised IAM
2190-9173	Mapnet 2 Loop powered 2 Point Input / Output
Module	
4099-9032NL	Mapnet 2 Addressable Manual Call Point

Compatible Detectors, IDNET

The following lists the detectors approved for use with IDNet and shows current rating and numbers allowed per loop.

Device Type	Operating Current mA	Maximum Number Allowed Per Loop	Maximum Number Allowed Per Line
4098-9714E Analogue Photoelectric Smoke Detector	0.5 (2 with LED on)	250	40*
4098-9717E Analogue Ionisation Smoke Detector	0.5 (2 with LED on)	250	40*
4098-9733E Analogue Heat Type A & B Detector	0.5 (2 with LED on)	250	40*
4098-9754E Analogue Multi (Heat/Photo) Detector	0.5 (2 with LED on)	250	40*

* Maximum allowed by AS1670.1.

The above with 9714E, 9717E and 9733E use a (4098-) 9789E addressable base or 9794E addressable sounder base, or 9793 addressable isolator base. The 9754E uses a 9796E addressable base or 9795E sounder base.

The maximum specified loop/line resistance is 40Ω.

The maximum number of LEDs switched on by an IDNet in alarm is 20.

Compatible Addressable Field Devices, IDNet

The following lists the addressable devices approved for use with IDNet and shows current rating and numbers allowed per loop.

Device Type	Operating Current mA	Maximum Addressable Point On Analogue Loop	Maximum Addressable Points on Analogue Line
4090-9116 IDNet Comms Isolator	0.5 (2 with LED on)	250	40*
4090-9118 Relay IAM with T-sense	0.5 (2 with LED on)	250	40*
4090-9117 Addressable Power Isolator	0.5 (2 with LED on)	250	40*
4090-9118 Relay IAM with T-Sense Input	0.5 (2 with LED on)	250	40*
4090-9119 Relay IAM with unsupervised Input	0.5 (2 with LED on)	250	40*
409-9120 6 Point I/O	0.5	250	40*
4090-9001 Supervised IAM	0.65 (2.8 with LED on)	250	40*
4090-9101 Monitor ZAM	0.65 (2.8 with LED on)	250	40*
4099-9032 Manual Call Point	0.65 (2.8 with LED on)	250	40*

* Maximum allowed by AS1670.1.

The maximum specified loop/line resistance is 40Ω.

The maximum number of LEDs switched on by an IDNet in alarm is 20.

The 6 Point I/O LED is powered from the external 24V supply, not from the loop.

Note: The relays on the 6 Point I/O are not approved for switching field loads, i.e. the contacts may only be used to switch loads within an earthed cabinet.

Appendix G

Compatible Batteries

The following batteries are compatible with the 4100U.

- Power Sonic PS12 Series
 - Century Power Sonic PS12 series
 - Sonnenschein A200 Series
 - Sonnenschein A300 Series
 - Century Yuasa NP Series
 - Auscell CJ12 series
 - Power Block PB12 series
-

Appendix H

4100U Specifications

General

System Capacity	2,000 points of addressable points, plus 2,000 points of annunciation.
Expansion	Up to capacity above.
Cabinet Size	Up to 119 Addressable cards
Cabinet Material	Dependent on system configuration
Cabinet Finish	1.6mm Zintex
Cabinet Colour	Powder coated
Mounting	Cream Wrinkle
	Wall mount
Mains Input	240V AC, +6%, -10%, 50Hz
Internal Power Supply	24V DC @ 9A
Standby Battery	24V sealed lead acid up 110Ah
Battery Charger	27.3V DC (nominal)
PSU Supervision	Charger high/low, Battery low/fail
Temperature	-5°C to 45°C
Humidity	10% to 90% RH non-condensing

Refer to Table 6-1, 6-2 for full SPS specifications.

Fuses

Alarm Relay Card
F1 Alarm, 3A, 15 x 5mm, Glass Cartridge
F2 Supervisory, 3A, 15 x 5mm, Glass Cartridge
F3 Trouble, 3A, 15 x 5mm, Glass Cartridge

Fused Distribution Board (if fitted)
F1 24V Out, 1A 20 x 5mm Glass Cartridge
F2 24V Out, 1A 20 x 5mm Glass Cartridge
F3 24V Out, 1A 20 x 5mm Glass Cartridge
F4 24V Out, 1A 20 x 5mm Glass Cartridge

Firmware Features

- WALK TEST System Test
 - 4 Operator Access Levels
 - Event Historical Logging
 - Device selectable Alarm Verification
 - Individual Zone Isolate
 - Addressable device disable/enable
 - Non-volatile Flash EPROM for field editable program changes
 - Expansion cards firmware upgraded via download to flash EPROMs
-

Voltage & Current Ratings of Modules & Assemblies

The DC input voltage range of the following modules is 18-33Vdc. The current listed is nominal for 24Vdc, and may be used for battery capacity calculations.

Module	Name	Quiescent	Alarm
N/A	Master Controller Assembly (includes SPS, CPU, CPU Motherboard with RUI I/F, Operator Interface with LCD)	373mA	470mA
4100-6035	Alarm Relay Card	15mA	37mA
4100-3101	IDNet Module without Devices - per device add - with 250 devices add	75mA 0.8mA 200mA	115mA 1mA 250mA
4100-1289	64/64 Controller plus Switch LED Modules - no LED on - per LED on add - with 64 LEDs on add	20mA 3mA 210mA	3mA 210mA
4100-0620	Transponder Interface, Basic Unit	87mA	87mA
4100-0625	Transponder Interface, Local Mode	112mA	112mA
4100-6014	Network Interface Card	28mA	28mA
4100-6056	Wired Media Module	55mA	55mA
4100-6057	Fibre Optic Media Module	25mA	25mA
4100-6038	Dual RS232 Interface	132mA	132mA

Appendix I

Power Supply & Battery Capacity Calculations

Power Supply

Part of the system design includes calculating that the quiescent load and the alarm load are each less than the rating of the power supply.

Note that the quiescent load includes devices such as door holders that are normally energized, but get switched off during alarm.

The SPS rating is included in the specifications in Chapter 6.

Refer to AS1670.1 Section 8.2.3 for a definition of the loads to be calculated.

Battery Capacity

Battery capacity requirements are specified in AS1670.1, 2004, Section 3.16.4 with an example shown in Appendix C1.

Calculate the quiescent load (I_q) and alarm load (I_a) from the currents listed in the specifications (Appendix H of this manual). Follow the example in AS1670.1.

Note that the system current for both the quiescent and the alarm state can be checked on the panel by use of the System Current status point under Card Status for the SPS.

Appendix J

Cable Characteristics

IDNet

The IDNet cabling requirements are detailed in Chapter 8 of this manual.

4100 MAPNET II

Line Characteristics

Note: In the following paragraphs the term "MAPNET channel" is used to mean those lines connected to any one Mapnet Transceiver board. Parallel runs from the same board do not constitute separate channels. The term "continuous run" refers to the loop distance from the primary output, through all devices and back to the secondary output.

Line characteristics are based on 0.58uF and/or 35 Ohms total line resistance.

Total length of line on one MAPNET channel shall not exceed 3,000 m including all T-taps and parallel runs.

Maximum length for ONE continuous MAPNET run is 1200 m for up to 128 MAPNET devices using 1.5 mm sq cable.

When the run exceeds 850 m it is necessary to use twisted, shielded pair.

NETWORK

Copper Line Characteristics

Network "Wired" (*formerly called RS-485*) Communication wiring shall be 0.75 mm sq twisted, shielded pair (TSP), or 0.22 mm sq twisted pair (TP). Shielded Cable is recommended for new installations. When shielding is used, the shield shall be connected to Earth Ground, at the Left Port end of span only.

No T-tapping of the Network conductors is allowed. Network wiring is point-to-point, only.

Maximum line length between ports at 57,600 and 9600 bits per second is shown in the table below.

Communication Speed	Maximum Wiring Distance	
	0.75mm sq TSP Wire. (Maximum capacitance between conductors is 174 pf. per meter)	0.22mm sq TP Wire. (Maximum capacitance between conductors is 66 pf. per meter)
57,600 bps	3,000 m	2,300 m
9600 bps	5,600 m	4,000 m

Table J- 1 Network: Maximum Transmission Distances, "Wired" Network

Continued on next page

Network, Continued

Fibre Optic Cable Characteristics

All fibre cables shall be multimode, graded index. ST style connectors must be used. No physical strain shall be put on the cables. There must be no cable bends of less than a 50mm radius.

Two methods are available for joining fibre cable. Splices provide a permanent, very low loss, fibre-to-fibre connection. Couplers provide temporary connection between two ST style connectors with a loss of 1.2dB. Both methods are permitted on a fibre Network.

The characteristics of the 4100-0143 fibre optic media card are as follows. Minimum Launch Power into a 50/125 cable is 50 uW (-13 dBm). Minimum Launch Power into a 62.5/125 cable is 109.5 uW (-8.6 dBm). The maximum value for the minimum input sensitivity of the receiver is 1.0 uW (-30 dBm).

Maximum line lengths for 50/125 and 62.5/125 cable are shown in the table below.

Fibre Cable	Loss Per Kilometer	Power Margin	Maximum distance
50/125 Fibre	4 db	4 db	3,050 meters
50/125 Fibre	3 db	3 db	4,500 meters
62.5/125 Fibre	4 db	4 db	4,000 meters
62.5/125 Fibre	3.75 db	3 db	4,500 meters

Table J-2 Network: Maximum Distances, Optical Fibre

All the information above is based on the **minimum** launch power of the transmitter into the specified cable and the **maximum value** of the minimum input sensitivity of the receiver

Appendix K

List of Drawings

The following drawings are included and are referred to in the manual or are considered relevant.

1901-267	Sheet 2, 4100U AIU/PSU Wiring Assembly Drawing
1919-22	RAC Cabinet Mounting Drawing
1963-51	KT0193 3U RAC Mounting ASE Drawing
1963-62	ASE FAS Interface Drawing
1976-133	18U FIP Presentation Drawing
1976-136	18U FIP Assembly Drawing
1976-137	21U-40U Assembly Drawing
1976-141	28U FIP Presentation Drawing
1976-142	40U FIP Presentation Drawing
1976-143	18U Expansion Presentation Drawing
1976-144	28U Expansion Presentation Drawing
1976-145	40U Expansion Presentation Drawing



FIRE • SECURITY • COMMUNICATIONS • WORLDWIDE SALES & SERVICE

©2004 Tyco Safety Products Westminster, Westminster, MA 01441-001 USA. Specifications and other information shown were current as of publication, and are subject to change without notice.

Free Manuals Download Website

<http://myh66.com>

<http://usermanuals.us>

<http://www.somanuals.com>

<http://www.4manuals.cc>

<http://www.manual-lib.com>

<http://www.404manual.com>

<http://www.luxmanual.com>

<http://aubethermostatmanual.com>

Golf course search by state

<http://golfingnear.com>

Email search by domain

<http://emailbydomain.com>

Auto manuals search

<http://auto.somanuals.com>

TV manuals search

<http://tv.somanuals.com>