

# INSTALL GUIDE

## 430 and 440 Series Vehicle Security Systems

REMOTE STARTERS

CAR ALARMS



ULTRA  
START

**WWW.ULTRASTARTERS.COM**

**Technical Support 866-698-5872 ext 0**

**Support@ultrastarters.com**

Note: Some features may not be available on certain models.

### **FCC/ID Notice**

This device complies with Part 15 of the FCC rules. Operation is subject to the following conditions:

- (1) This device may not cause harmful interference, and
- (2) This device must accept any interference received, including interference that may cause undesired operation.

**CAUTION:** Changes or modifications not expressly approved by the part responsible for compliance void the user's authority to operate this device.

# TABLE OF CONTENTS

<b>Table Of Contents</b>	<b>Page 2</b>
<b>Wiring Diagram</b>	<b>Page 3</b>
<b>Installation Tips</b>	<b>Page 4</b>
Pre-Installation Suggestions	
<b>Installation Suggestions</b>	
Mounting The Module	
Installing The LED	
Installing The Program Button	
Under Hood Connections	
Mounting The Siren	
<b>Wire Connectors</b>	<b>Page 5</b>
14 Pin Main Harness Connector	
4 Pin Red Connector- Keyless Entry	
2 Pin Connector Red- Plug-in LED	
2 Pin Blue Connector- Plug-in Program Button	
3 Pin White Connector- Aux. outputs	
4 Pin White Connector- Addition sensor input	
<b>Installation</b>	<b>Page 6-7</b>
Basic Installation - Quick start	
Shock Sensor Adjusting	
Test The System	
<b>Programming</b>	<b>Page 7-9</b>
Program Overview	
Quick View Programming	
<b>System Reset</b>	
<b>Operations</b>	<b>Page 10</b>
Transmitter Programming	
Battery Replacement	
<b>Other Features</b>	<b>Page 11</b>
System Service Mode	
Service Mode- By remote	
<b>Diagnostics</b>	<b>Page 12</b>

## COMPONENTS

- Three Button Remote transmitter's (430 Series)
- Four Button Remote transmitter's (440 Series)
- Plug-in Valet Switch (Program Switch)
- 10 Pin Main Harness
- 2 pin Keyless Entry harness
- Control Module
- Plug-in Led
- Multi-Tone Siren
- Installation Guide
- Owners Manual

# WIRING DIAGRAM

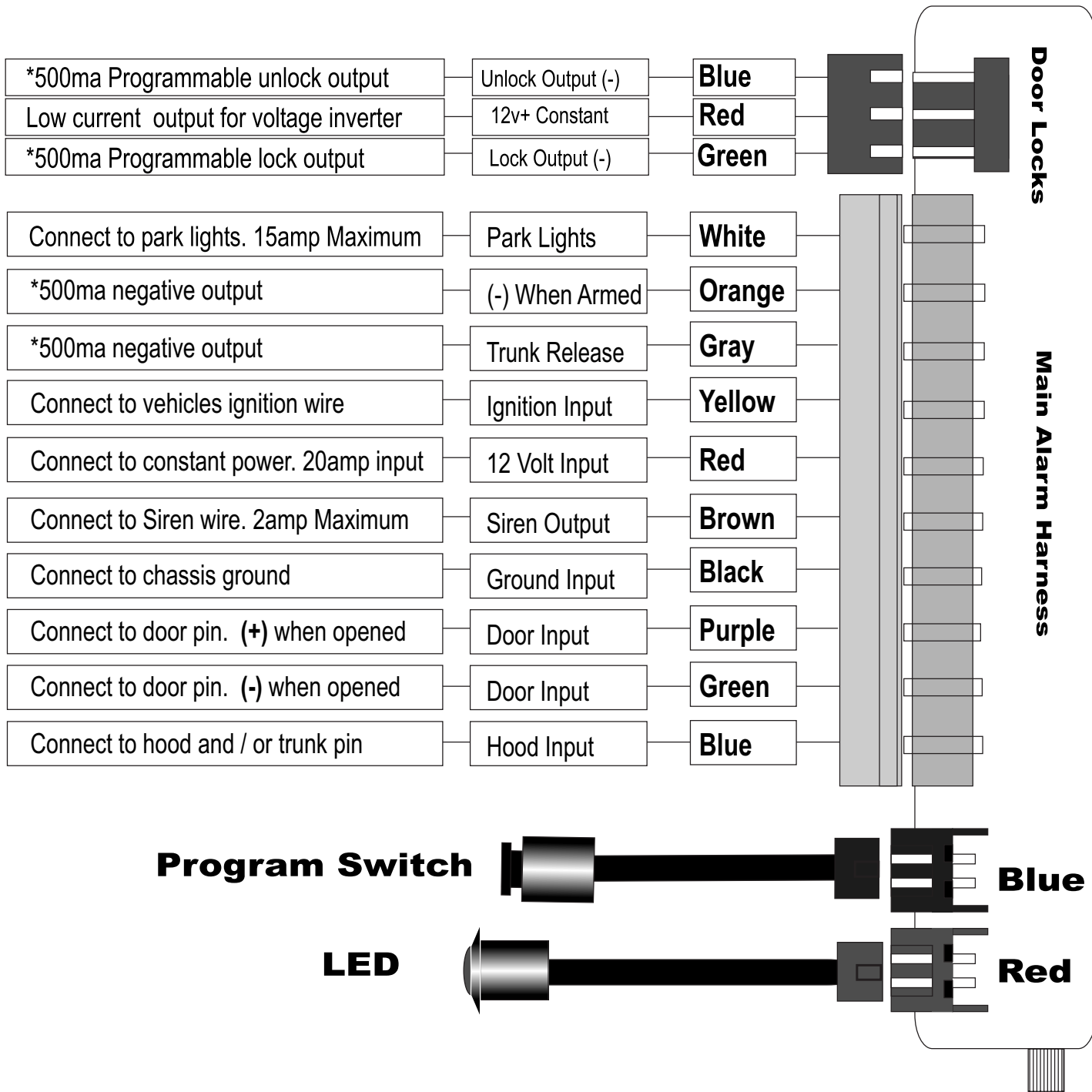

## Shock Sensor Adjustment

**Increase Sensitivity** - Turn the adjustment screw clockwise.

**Decrease Sensitivity** - Turn the adjustment screw counter clockwise.

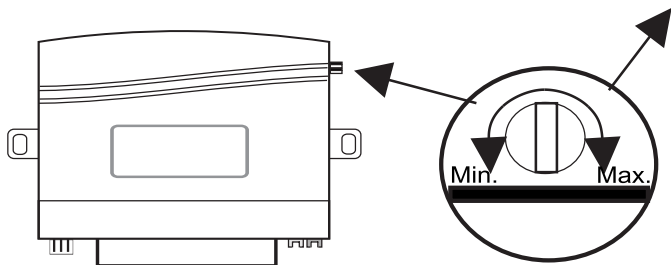

**\*500ma outputs are low current and are designed to activate relays**

# WIRING CONNECTIONS

## 10 Pin Connector

White	(+) Park lights	Park light output.
Orange	(-) When Armed	Negative output when system is armed.
Grey	(-) Trunk Release	Negative output for trunk release. <b>500ma max.</b>
Yellow	Ignition Input	Input from vehicles ignition wire.
RedMain	Power Input	Constant 12 Volt input.
Brown	(+) Siren Output	Positive output for siren.
Black	Ground Input	System ground input.
Purple	(+) Door Input	Positive door pin switch input.
Green	(-) Door Input	Negative door pin switch input.
Blue	(-) Hood Input	Negative input from hood pin switch.

## 3 Pin Connector Red

Green	Door Lock	Door Lock Output - <i>*Programmable</i>
12 Volt Output	Output for voltage inverter.	<b>Low Current Only</b>
Blue	Door Unlock	Door Unlock Output - <i>*Programmable</i>

## Recommended Installation Procedures

**Mounting the module-** Never mount the module in the engine compartment. Select a location under the dash to install the main module. Be certain that the module is securely attached and does not obstruct any serviceable areas. Mount the module so that it cannot be seen if looking under the dash as it could be easily unplugged by a thief. The module must be free from all moving parts.

**Installing the LED-** Choose a location that will be highly visible when the LED is installed. Most vehicles are equipped with knock out panels in the dashboard, these panels are easily removable and can be easily replaced if necessary. Once the location is picked, use drill bit and drill a hole through the panel. Test fit the LED into the hole. Plug the Led into the **Red** connector on the main module.

**Installing the Program Button-** Choose a location to mount the Program Button. This location should be hidden and not visible from outside the vehicle. Once the location of the switch is picked, use a 1/4" drill bit and drill a hole. Remove the nut and push the Program Button through the hole. Replace the nut and tighten until the switch is secure. Plug the Program Button into the **Blue** connector of the main module.

**Under Hood Connections-** Route the hood pin (optional) and Siren wire through the firewall, into the engine compartment. Always try to pull the wires through a factory rubber grommet. If drilling through the firewall, BE CAREFUL. Check for obstructions on both sides of the firewall. After drilling use a snap in grommet to protect the wires from sharp edges.

**Mounting the Siren-** Choose a location in the engine compartment that is away from high heat sources and direct exposure to water. The siren should be mounted as well as grounded to solid metal. Run the wiring for the siren so that it can not be seen or reached from below the vehicle.

# BASIC INSTALLATION

## Step 1 - Connect All Of the Following Wires

### 10 Pin Power Connector

Black	Ground Input	System ground input.
Yellow	Ignition Input	Input from vehicles ignition wire.
Red	Power Input	Constant 12 Volt input.
Brown	(+) Siren Output	Positive output for siren.
White	(+) Park lights	Positive park light output.
Green*	(-) Door Input	Negative door pin switch input.
Purple*	(+) Door Input	Positive door pin switch input.

\*Test for door pin type (+ or -) then connect the appropriate wire (Green or Purple)

## Step 2- Plug-In The Module

When all the connections are done, the control module can be plugged in. Before connecting the control module, make sure the ignition is in the **OFF** position. Plug in the main harness then any other connectors that were used.

## Step 3- Test And Adjust The Shock Sensor

To test the Shock Sensor.

1. Press the **Lock** button once to arm the system.
2. Wait five seconds then impact the vehicle. Lighter impacts to the vehicle should trigger the warn away (The siren will chirp three times). A harder impact to the vehicle will trigger the full alarm.(The siren will activate for 60 seconds then turn off).
3. To deactivate the alarm when triggered, press the **unlock button twice**.

To Increase The Sensitivity.

Turn the adjustment screw **Clockwise** 1/4 turn then re-test the sensitivity. Repeat this procedure until the sensitivity of the system is at the appropriate level.

\*\* **Do not set to sensitive.**

To Decrease The Sensitivity.

Turn the adjustment screw **Counter Clockwise** 1/4 turn then re-test the sensitivity. Repeat this procedure until the sensitivity of the system is at the appropriate level.

## Step 4- Test The System

1. Open all the vehicles windows.
2. Press the Lock button to arm the system.
3. Wait five seconds (or until the dome light goes out) then reach in through a window and open the door. The alarm will then activate (repeat on all the doors).
4. Test the Shock Sensor again and adjust if necessary.
5. Insure that all additional features are working as intended.
6. If necessary proceed to Program Mode to adjust the programmable outputs.

**Your Basic Install Is Complete!**

# PROGRAM OVERVIEW

Program mode allows you to adjust the settings and options of your system. Your system has been intelligently designed by installers with years of experience. The system's default settings do not require any program changes in most cases. However, this system does incorporate a advanced programming system with settings that can be easily adjusted

## Entering Program Mode

### To Enter Program Mode

- 1) Make sure ignition is in the off position.
- 2) Within three seconds turn the key **ON the OFF**.
- 3) Press and release the Program Button **two times**.
- 4) The siren will chirp and the lights will flash once to confirm entering Program Mode.

**Note:** *If unit does not enter Program Mode, turn ignition off and repeat steps 1-3.*

**\*\*** The ignition wire(Yellow) **MUST** be connected. If it is not connected it will not be possible to enter the Program Modes.

## Changing A Programmable Setting

- 1) Enter Program Mode As explained above.
- 2) When in program Mode, change the desired Program Setting by pressing the transmitter buttons in the following sequences.

**\*\*\*The Systems Default Setting Are Shown In Bold Lettering.**

## Quick View Programming

Programmable Feature	Press Buttons	One Chirp	Two Chirps
Shock Sensor Status	<b>#3-#3-#1</b>	Disabled	<b>Enabled</b>
Arm / Disarm Chirps	<b>#2-#1-#1</b>	Chirps Off	<b>Chirps On</b>
Ignition Auto Locks	<b>#1-#3-#2</b>	Off	<b>On</b>
Door Lock Pulse Length	<b>#1-#3-#1</b>	3 Second	<b>.75 Second</b>
Double Pulse Unlock	<b>#2-#2-#1</b>	Two Pulses	<b>Single Pulses</b>
Door Input / Voltage Sense	<b>#1-#1-#3</b>	Voltage	<b>Door Pin</b>
Passive / Active Locks	<b>#3-#2-#2</b>	<b>Active</b>	Passive
Passive / Active Arming	<b>#1-#2-#3</b>	<b>Active</b>	Passive
System Reset	<b>#3-#3-#3</b>	<b>Confirmed by Three Siren Chirps</b>	

## System Reset

This feature will reset the module to it's factory programmed default setting. This feature will not delete transmitter codes from memory.

### To Reset The System To Factory Defaults.

- 1) Turn the ignition key On then Off.
- 2) Press the Program Button two times. The system will respond with two siren chirps.
- 3) Press the transmitter buttons in the following order: **#3-#3-#3**. The system will respond with three siren chirps to confirm the system has been re-set to factory defaults.

# PROGRAMMABLE FEATURES

## Enter Program Mode

Entering program mode is done by the following steps:

- 1) Make sure ignition is in the off position.
- 2) Turn the ignition key ON - OFF, leaving **key in the OFF position**.
- 3) Press and release the Valet button two times.
- 4) The siren will chirp one time to confirm entering program mode.  
( If this does not happen, turn ignition off, wait five seconds and repeat steps 1-4).

## Passive / Active Arming

To change settings:

- 1 - Enter Program Mode - (Ignition ON-OFF, followed by Valet 2 times)
- 2 - Press & release transmitter buttons in the following sequence  
**#1 - #2 then #3**
- 3 - The siren will respond with the following:  

<b>1 Chirp</b>	<b>Active Arming</b>
2 Chirps	Passive Arming

*Repeat sequence to change selection*

## Passive / Active Arming

To change settings:

- 1 - Enter Program Mode - (Ignition ON-OFF, followed by Valet 2 times)
- 2 - Press & release transmitter buttons in the following sequence  
**#3 - #3 then #2**
- 3 - The siren will respond with the following:  

<b>1 Chirp</b>	<b>Active Locks</b>
2 Chirps	Passive Locks

*Repeat sequence to change selection*

## Door Lock Timing

To change settings:

- 1 - Enter Program Mode - (Ignition ON-OFF, followed by Valet 2 times)
- 2 - Press & release transmitter buttons in the following sequence  
**#1 - #3 then #1**
- 3 - The siren will respond with the following:  

1 Chirp	3 Second Door Locks
<b>2 Chirps</b>	<b>0.75sec Pulses</b>

*Repeat sequence to change selection*

## Ignition Auto Locks

To change settings:

- 1 - Enter Program Mode - (Ignition ON-OFF, followed by Valet 2 times)
- 2 - Press & release transmitter buttons in the following sequence  
**#1 - #3 then #2.**
- 3 - The siren will respond with the following:  

<b>1 Chirp</b>	<b>Auto Lock Disabled</b>
2 Chirps	Auto Lock Enabled

*Repeat sequence to change selection*

# PROGRAMMING

## Double Pulse Unlock

### To change settings:

- 1 - Enter Program Mode - (Ignition ON-OFF, followed by Valet 2 times)
- 2 - Press & release transmitter buttons in the following sequence  
**#2 - #2 then #1.**
- 3 - The siren will respond with the following:  
1 Chirp      Double Pulse Unlock  
**2 Chirps      Single Pulse Unlock**  
*Repeat sequence to change selection*

## Voltage / Door Pin Sensing

### To change settings:

- 1 - Enter Program Mode - (Ignition ON-OFF, followed by Valet 2 times)
- 2 - Press & release transmitter buttons in the following sequence  
**#1 - #1 then #3**
- 3 - The siren will respond with the following:  
1 Chirp      Voltage Sensing- No Door Pin Connection Needed  
**2 Chirps      Door Pin- Door Pin Connection Required**  
*Repeat sequence to change selection*

## Chirp Delete

### To change settings:

- 1 - Enter Program Mode - (Ignition ON-OFF, followed by Valet 2 times)
- 2 - Press & release transmitter buttons in the following sequence  
**#2 - #2 then #1**
- 3 - The siren will respond with the following:  
1 Chirp      Chirps Disabled  
**2 Chirps      Chirps Enabled**  
*Repeat sequence to change selection*

## Shock Sensor Disable

### To change settings:

- 1 - Enter Program Mode - (Ignition ON-OFF, followed by Valet 2 times)
- 2 - Press & release transmitter buttons in the following sequence  
**#3 - #3 then #1**
- 3 - The siren will respond with the following:  
1 Chirp      Shock Sensor OFF  
**2 Chirps      Shock Sensor ON**  
*Repeat sequence to change selection*



# TRANSMITTER PROGRAMMING

## Transmitter Programming

Follow the steps below to program the transmitters to the system s memory

**Step 1** - Turn the Ignition key **ON then OFF - Leaving Key Off.**

**Step 2** - Press and release the Program Button **twice then press and hold.**

**Step 3** - The siren will respond with five chirps to confirm Transmitter Program Mode.

**Note:** If the siren does not respond, repeat Steps1&2

**Step 4** - Continue to hold the Program Button and press lock button on each of the transmitter's to be programmed(Maximum of 3 Different transmitter codes).

**Step 5** - The system will respond with a siren chirp each time a transmitter is programmed.

**Exit** - After five seconds the system will exit transmitter program mode automatically.

**NOTE:** You must program ALL of the transmitters to be used at one time. For the owner's security any transmitters not programmed at this time will be erased from memory.

**\*\*\* This system will store a maximum of three transmitter codes in memory.**

## Deleting Transmitters

Follow the steps below to permanently delete a transmitter code from the system s memory.

**Step 1** - Turn the Ignition key **ON then OFF - Leaving Key Off.**

**Step 2** - Press and release the Program Button **twice then press and hold.**

**Step 3** - The siren will respond with five chirps to confirm Transmitter Program Mode.

**Note:** If the siren does not respond, repeat Steps1&2

**Step 4** - Continue to hold the Program Button and press lock button on only the transmitters that are intended for use on the system.(\*Maximum of 3 Different transmitter codes).

**Step 5** - The system will respond with a siren chirp each time a transmitter is programmed.

**Exit** - After five seconds the system will exit transmitter program mode automatically.

**All previous transmitter code are now deleted from the systems memory.**

## Basic Transmitter Functions

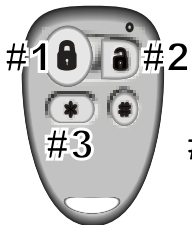

**Button #1-** Press and release to arm the alarm and lock the doors.  
- Press and hold to activate Panic mode.  
- Press and release to deactivate triggered alarm.

**Button #2** Press and release to disarm and unlock the doors.  
- Press and hold to activate the Trunk Release.  
- Press and release to deactivate triggered alarm.

**Button #3** Press and hold to activate the Car Finder Mode.

# SYSTEM OPERATION



## Lock Doors & Arm The Alarm

1. Press & release the **LOCK** button on the remote transmitter.
2. The park lights will flash and the siren will chirp once.
3. The doors will lock.
4. The LED will start flashing within five seconds.



## Unlock Doors & Disarm The Alarm

1. Press & release the **UNLOCK** button on the remote transmitter.
2. The park lights will flash and the siren will chirp twice.
3. The doors will unlock.
4. The LED will stop flashing.



## Silent Arm And Disarm

1. Press & release the button three, then press & release the lock or unlock button.
2. If the doors are locked this will unlock the doors without siren chirps, the park lights will flash two times to confirm the doors have unlocked.
3. If the doors are unlocked this will lock the doors without siren chirps, the park lights will flash one time to confirm they have locked.



## Trunk Release

1. Press and hold the **UNLOCK** button for three seconds.
2. The doors will unlock, continue holding the unlock button three seconds. the Trunk release will then activate. The trunk release will be confirmed by one park light flash.
3. For safety reasons, the trunk release output will not activate when ignition key is in the "On" position.



## Car Finder Mode

1. Press and hold the **\*** button for two seconds.
2. The system will flash the park lights and chirp the siren five times.

\*\*This feature can help find your vehicle in a crowded parking lot.



## Panic Mode

1. Press & hold the **LOCK** button for three seconds.
2. The park lights will flash and the siren will activate.

### PANIC MODE DISABLE

1. Press **LOCK** button to disable the panic mode and to lock the doors.
2. Press **UNLOCK** button to disable the panic mode and unlock the doors.
3. Panic Mode will stay activated until disabled by the remote transmitter.



## Service Mode

1. The system must be disarmed and the ignition is turned OFF.
2. Press and release the lock and unlock buttons at the same time, then press and hold the lock button for five seconds.
3. The system will respond with **five chirps** and park light flashes to confirm that the system is in Valet mode.
4. The LED will stay **ON** steady to confirm Valet Mode.



## Exit Service Mode

1. Press and release the lock and unlock buttons at the same time, then press and hold the lock button for five seconds.
2. The system will respond with **two chirps** and park light flashes to confirm that the system has exited Valet mode.
3. The LED will turn **OFF**.

**Note:** If the LED does not turn off, check that all the door's are closed. The LED stays On solid when a door is left opened.



## Emergency Service Mode

Emergency Service Mode temporarily disables the alarm system. This feature can be used if the remote is lost or if the system malfunctions.

### ENTERING VALET MODE

1. While the ignition is "On" press and hold the Service button for five seconds. The siren will chirps **five** times.

2. Alarm functions will be disabled and the LED will be **ON** steady. The door-locks and trunk release are still operational.

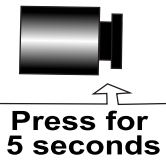

### EXITING VALET MODE

1. While the ignition is "On" press and hold the Service button for five seconds. The siren will chirps **two** times.

2. The system returns to normal operation.

## Starter Disable

The system has an optional starter disable output that can be connected by your dealer. When the starter disable relay is installed and connected to the system, the vehicle's starter will be disabled when the system is armed.



**To activate** the starter disable press the lock button on the remote. The system will arm and the starter will no longer operate.

**To deactivate** the starter disable, press the unlock button and the LEDS will stop flashing and the starter will be re-enabled.

# Door Lock Relays

## Negative Type Door Locks

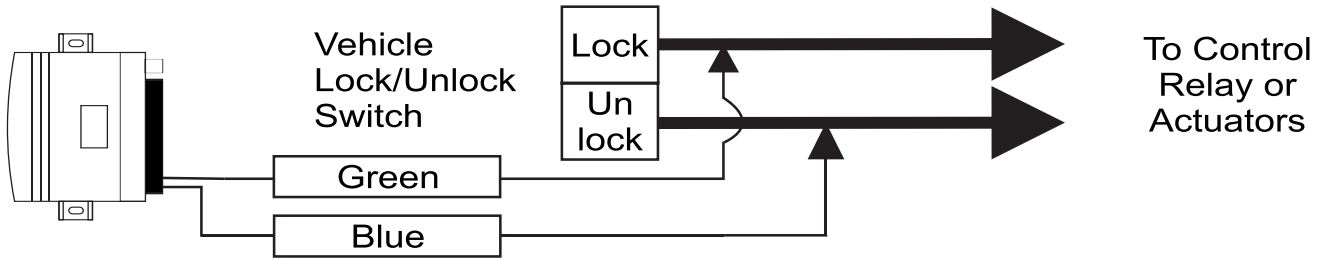

## Positive Type Door Locks

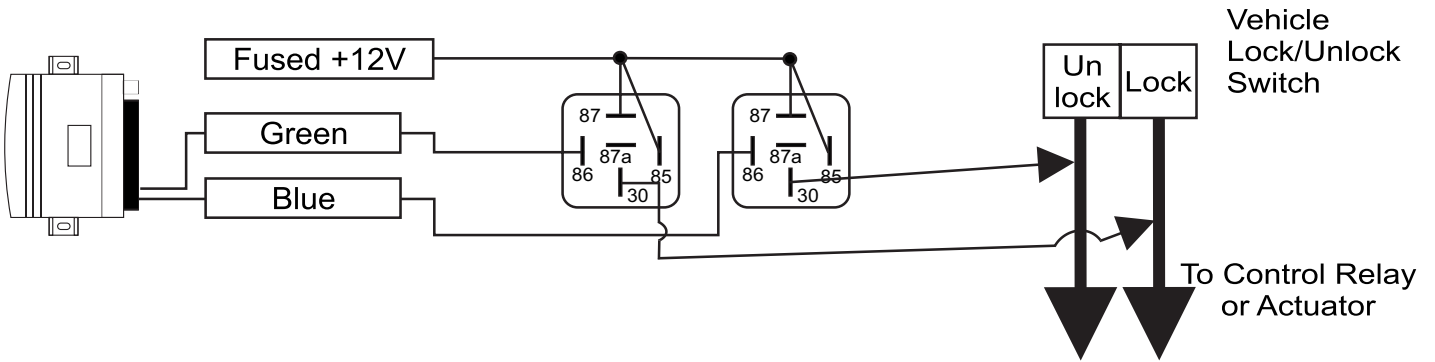

## 5 Wire / Reverse Polarity Type Door Locks

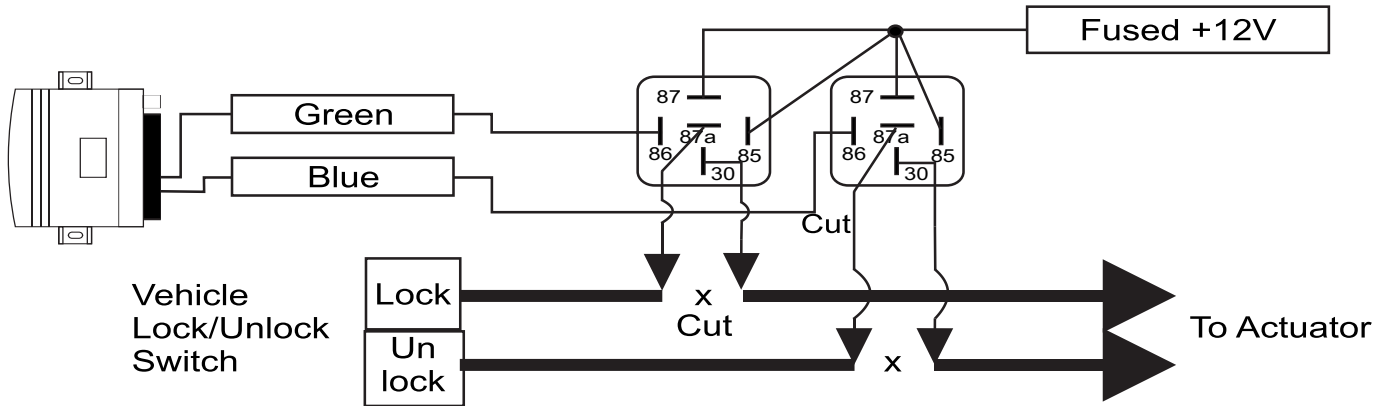

**Negative Park Lights-** In some cases the park lights may flash erratically after installing the negative park light relay. To correct this issue add a diode between the coil pins of the relay as shown.

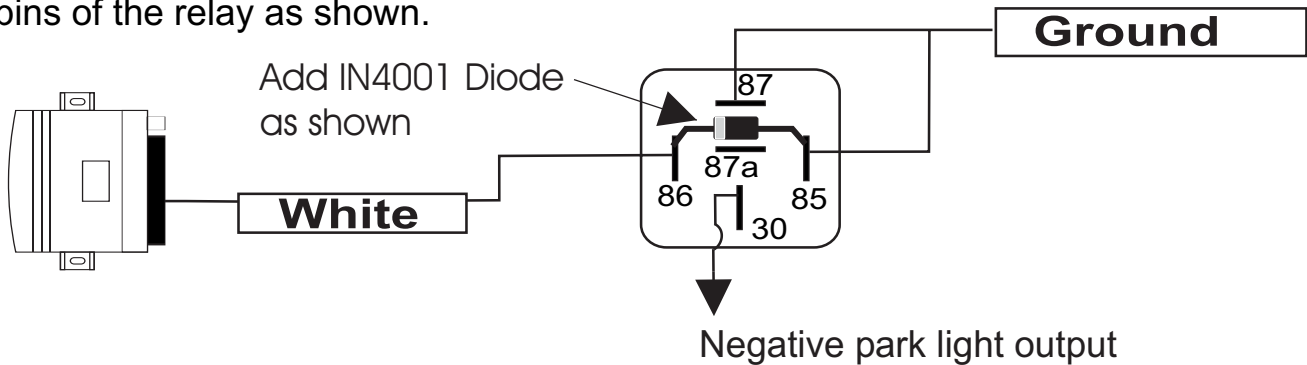

## Free Manuals Download Website

<http://myh66.com>

<http://usermanuals.us>

<http://www.somanuals.com>

<http://www.4manuals.cc>

<http://www.manual-lib.com>

<http://www.404manual.com>

<http://www.luxmanual.com>

<http://aubethermostatmanual.com>

Golf course search by state

<http://golfingnear.com>

Email search by domain

<http://emailbydomain.com>

Auto manuals search

<http://auto.somanuals.com>

TV manuals search

<http://tv.somanuals.com>