

U.S.A. Model

INSTALL GUIDE

KE-4 KEYLESS ENTRY SYSTEM

REMOTE STARTERS

CAR ALARMS

ULTRA
START

WWW.ULTRASTARTERS.COM

Technical Support 866-698-5872 ext 0

Support@ultrastarters.com

Note: Some features may not be available on certain models.

FCC/ID Notice

This device complies with Part 15 of the FCC rules. Operation is subject to the following conditions:

- (1) This device may not cause harmful interference, and
- (2) This device must accept any interference received, including interference that may cause undesired operation.

CAUTION: Changes or modifications not expressly approved by the part responsible for compliance void the user's authority to operate this device.



Installation Manual

Table Of Contents	Page 2
System Contents.	
Pre-Installation.	
Installation Tips.	
Main Wiring Diagram	Page 3
Quick Start Installation	Page 4
Wiring Description.	
Transmitter Operation.	
Transmitter Programming	Page 5
System Reset	
Quick View Programming Chart	
System Programming	Page 6
System Programming	Page 7
Relay Diagrams	Page 8

System Contents

- Control Module
- Four Button Remote Transmitter(s)
- 10-Pin Harness
- Installation Guide
- Owners Manual

Key Features

- Keyless Entry With Drivers Door Priority
- Trunk Release Output
- Positive Park Light Output
- Panic Mode
- Horn Honk Output
- Starter Disable Output

Pre-Installation

BEFORE STARTING:

- Discuss the optional features of the alarm with the owner of the vehicle.
- Do a walk around of the vehicle. (Note any scratches or dents)
- Check with the vehicle's owner before installation of LED light.
- See if the owner has a preference for the location of the Valet Switch.
- Have vehicle wiring information ready before starting installation.

Installation Tips

- Leave a window open to avoid locking the key's in the vehicle.
- Use seat covers and floor mats to protect the vehicle.
- Avoid disconnecting the battery.
- Unplug the dome light fuse to prevent battery drain.
- Test all connections with a voltmeter or circuit safe test light.
- Install the wire harness so that it is free of any moving parts.
- Solder all connections. Avoid using scotch-lok and crimp connectors.
- Pull the siren and optional hood pin wires through a factory rubber grommet into the engine compartment.(Do not use the steering boot).
- Install the siren away from high heat sources and direct exposure to water.

Installation Manual

KE-4

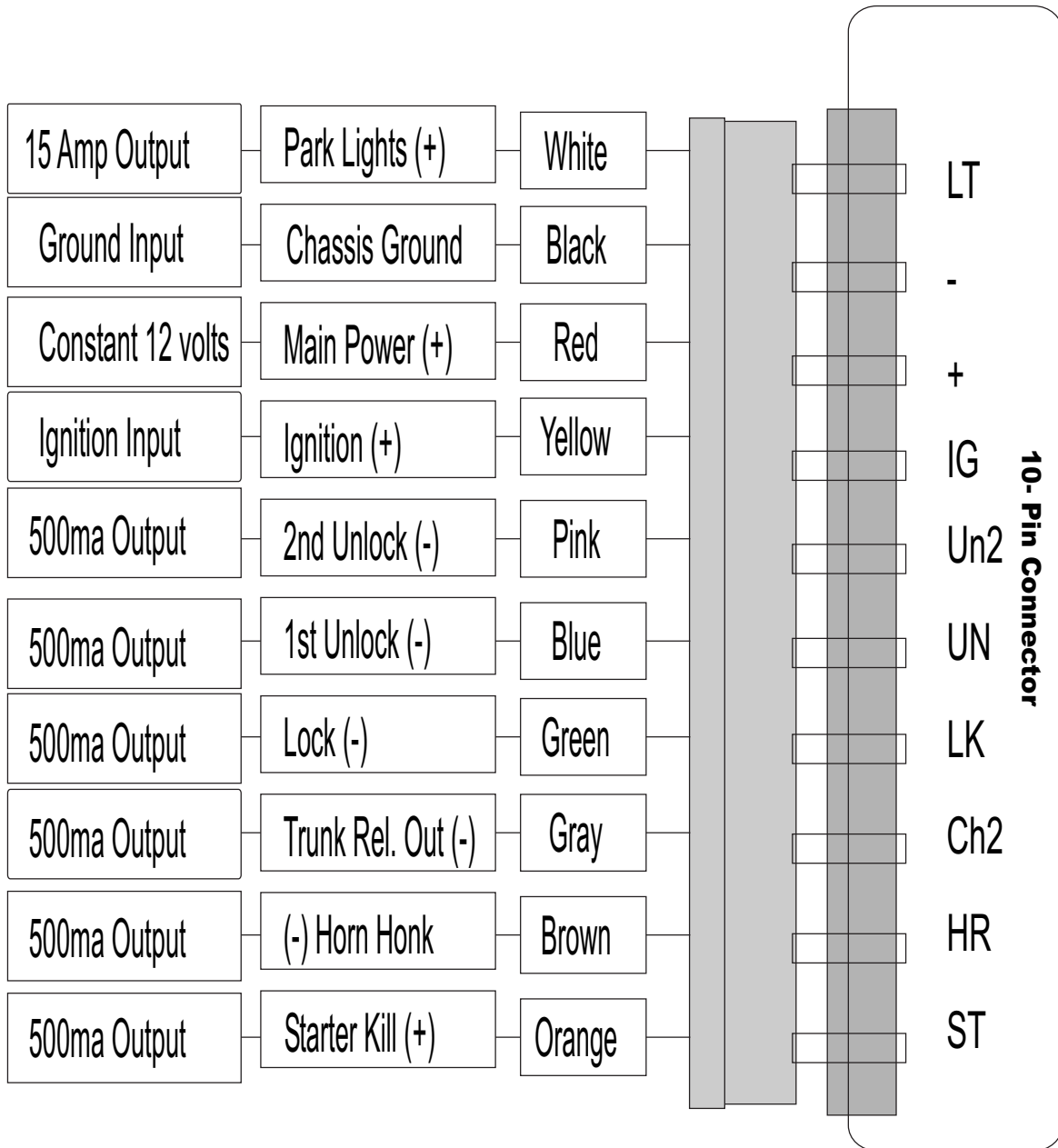

Antenna - Do Not Ground the antenna wire.

*****500ma outputs are low current and are designed to activate relays.**

STEP 1 - The following wires **MUST** be connected for proper operation.

Red	12v Power	(+) 15amp Input	Constant 12v power source.
Yellow	Ignition	(+) 12volt Input	Main ignition wire.
White	Park Lights	(+) 15amp Output	Connect to positive park lights
Black	Ground	(-) Input	Connect to chassis ground.
Green	Lock Output	(-)500ma Output	Connect to door lock relay.
Blue	Unlock Output	(-)500ma Output	Connect to door unlock relay.

Optional Connections

Orange	St.Disable	(-)500ma Output	Connect to Starter Disable relay.
Brown	Horn Output	(-)500ma Output	Connect to horn relay.
Grey	Trunk Output	(-)500ma Output	Connect to Trunk Release relay.
Pink	2nd Unlock	(-)500ma Output	Connect when installing Driver's Door Priority.

STEP 2 - CONNECT AND MOUNT THE MODULE

Plug the Connectors into the Module. Press the transmitter buttons to check for proper operation. Once it is determined that everything is working correctly the module can be mounted.

****Before plugging the module in make sure that Ignition Key is in the OFF position****

Mount the module by selecting a location under the dash that is secure. Be certain that the module does not obstruct any serviceable areas. The module must be free from moving parts such as brake, clutch and gas pedals and the linkages that are attached to them.

Basic remote operations



See Owners Manual for more transmitter operations

Installation Manual

KE-4

TRANSMITTER PROGRAMMING

To add additional transmitters and delete existing transmitter code(s) from memory.

- 1) Turn the ignition **On-Off-On-Off-On-Off-On-Off**. The park lights will flash twice.
- 2) Press the Lock button on the transmitters to be programmed.
- 3) The park lights will flash once, each time a new transmitter is learned.

*** If this does not happen wait ten seconds and repeat steps 1-3.

Note: Each system can store a maximum of three transmitter codes in memory.

Transmitter Program on "Power Up"

- 1) Plug in the module. (Leave the ignition in the Off position).
- 2) Press the lock button on each of the transmitters to be programmed.
- 3) The park lights will flash once each time a new transmitter code is learned.

Note: Previous transmitters that are not programmed at this time will be deleted from memory.

SYSTEM RESET

Reset To Factory Default Settings.

- 1) Make sure ignition is in the OFF position.
- 2) Turn the ignition key ON - **leaving key in the ON position.**
- 3) Press the transmitter buttons as follows. **Trunk-Lock-Unlock-Trunk.**
- 4) The system will respond by flashing the park lights three times

The system is now set to factory default settings.

QUICK VIEW PROGRAM MENU

Entering The Program Menu

- 1) Make sure ignition is in the OFF position.
 - 2) Turn the ignition key ON - **leaving key in the ON position.**
 - 3) Press the transmitter buttons in the appropriate sequence.
 - 4) After ten seconds the system will automatically exit Program Mode.
- To change a Programmable Feature press the transmitter buttons as follows.

*** **Default settings are shown in bold lettering.**

Passive / Active Arming	Lock-Unlock-Lock-Unlock	Passive	Active
Passive / Active Locks	Unlock-Trunk-Unlock-Trunk	Passive	Active
Ignition Auto Door Locks	Lock-Trunk-Lock-Trunk	ON	OFF
Door Lock Pulses	Lock-Unlock-Trunk-Lock	Three Second	.75 Second
Double Pulse	Unlock-Trunk-Unlock-Lock	Double Pulse	Single Pulse
Passive Warning Chirps	Lock-Trunk-Unlock-Trunk	ON	OFF
Reset To Factory Defaults	Trunk-Lock-Unlock-Trunk	Three flashes	Three Flashes

Entering The Program Menu

- 1) Make sure ignition is in the OFF position.
- 2) Turn the ignition key ON - **leaving key in the ON position.**
- 3) Press the transmitter button in the appropriate sequence.
- 4) After ten seconds the system will automatically exit Program Mode.

Setting 1 - Passive/Active Mode (Factory Default Setting: Active Mode)

Passive mode means that the system will automatically arm thirty seconds after The ignition key is turned off and the last door of the vehicle is closed.

Sometimes referred to as Automatic Arming.

Active mode means that the system will not arm until you manually turn it on by pressing the lock button on your transmitter.

1. Turn the ignition on. Ignition on means normal driving position.
2. Within 10 seconds, press and release the transmitter buttons

Lock Unlock Lock Unlock in succession.

PASSIVE MODE is confirmed with one horn chirp sound and **one** light flash.

ACTIVE MODE is confirmed with two horn chirp sounds and **two** light flashes.

Setting 2 - Passive Lock Mode (Factory Default Setting: Active Lock Mode)

Passive Lock Mode means that all doors will lock automatically when the system arms in the passive mode.

Active Lock Mode means that doors will lock only with the lock button.

- 1 Turn the ignition on. Ignition on means normal driving position.
- 2 Within 10 seconds, press and release the transmitter buttons

Unlock Trunk Unlock Trunk in succession.

PASSIVE LOCK MODE is confirmed with one horn chirp sound and **one** parking light flash.

ACTIVE LOCK MODE is confirmed with two horn chirp sounds and **two** parking Light flashes.

CAUTION: If the automatic door lock feature is installed and the system is Programmed to passive lock mode the doors will lock automatically when the system arms. It is always advisable to remove the ignition key each time you exit the vehicle.

Setting 3 - Ignition Auto Locks (Factory Default Setting: Locks Off)

Ignition Lock Mode means that all doors will lock automatically two (2)Seconds after the ignition key is turned on and will unlock automatically when the ignition key is turned off. This assumes that the keyless entry option has been installed by your Dealer. Sometimes referred to as Ignition Lock.

- 1 Turn the ignition on. Ignition on means normal driving position.
- 2 Within 10 seconds, press and release the transmitter button

Lock Trunk Lock Trunk in succession.

DRIVE LOCK MODE ON is confirmed with one horn chirp sound and one parking light flash.

DRIVE LOCK MODE OFF is confirmed with two horn chirp sounds and two parking light flashes.

Installation Manual

Setting 4 - Long Door Lock Pulse (Factory Default Setting: Pulse Off)

Long Door Lock Pulse means that the system can accommodate the factory central locking systems of import vehicles having vacuum door lock actuators that require a three-second lock pulse.

- 1 Turn the ignition on. Ignition on means normal driving position.
- 2 Within 10 seconds, press and release the transmitter buttons
Lock Unlock Trunk Lock in succession.

LONG DOOR LOCK PULSE MODE is confirmed with **one** parking light flash.
SHORT DOOR LOCK PULSE MODE is confirmed with **two** parking light flashes.

Setting 5 - Dual Unlock Pulse (Factory Default Setting: Dual Unlock Mode Off)

Dual Unlock Pulse means that the system can accommodate the factory central locking systems of import vehicles having dual unlock pulse to unlock the driver and passenger doors.

- 1 Turn the ignition on. Ignition on means normal driving position.
- 2 Within 10 seconds, press and release the transmitter buttons
Unlock Trunk Unlock Lock in succession.

DUAL PULSE ON is confirmed with one horn chirp sound and **one** parking light flash.
DUAL PULSE OFF is confirmed with two horn chirp sounds and **two** parking light flashes.

Setting 6 - Passive Warning Chirp (Factory Default Setting: Warning Chirp Off)

Passive Warning Chirp means that in passive mode (4.1) the system gives soft Warning chirp sounds during thirty second arming period after each temporary disarm.

- 1 Turn the ignition on. Ignition on means normal driving position.
- 2 Within 10 seconds, press and release the transmitter button
Lock Trunk Unlock Trunk in succession.

CHIRP ON is confirmed with one horn chirp sound and one parking light flash.
CHIRP OFF is confirmed with two horn chirp sounds and two parking light flashes.

Setting 7 -Reset to Factory Default

To Reset all programmable features to factory default setting:

- 1 Turn the ignition on. Ignition on means normal driving position.
- 2 Within 10 seconds, press and release the transmitter button
Trunk Lock Unlock Trunk in succession.

Reset to factory default is confirmed with three horn chirp sounds and three park Light flashes.

POSITIVE TRUNK RELEASE

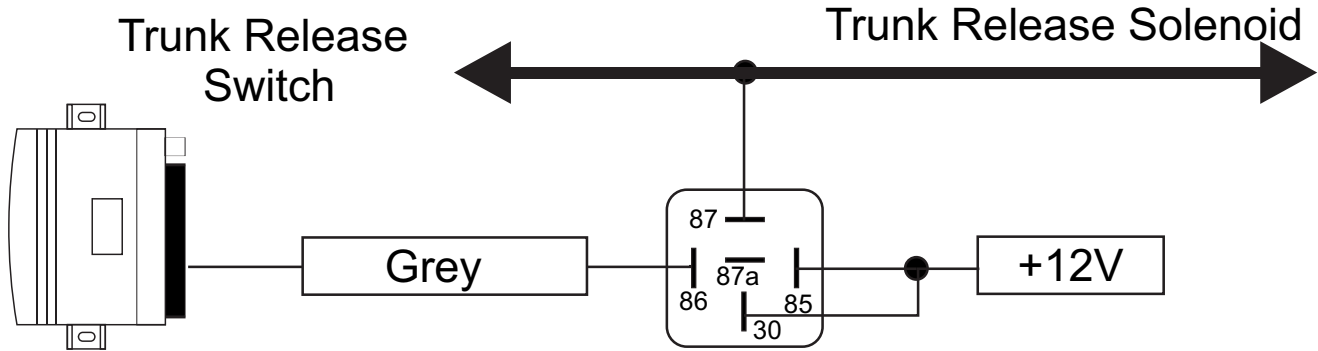

NEGATIVE PARK LIGHTS

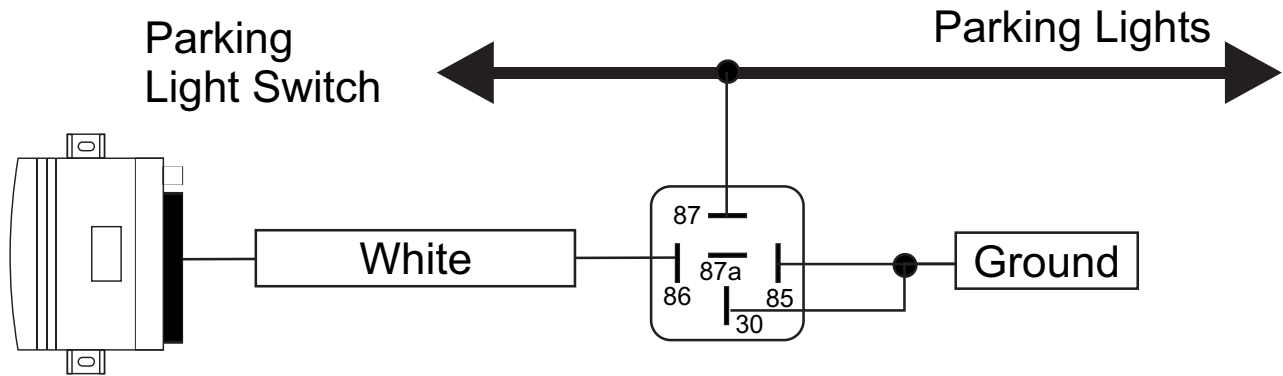

STARTER KILL

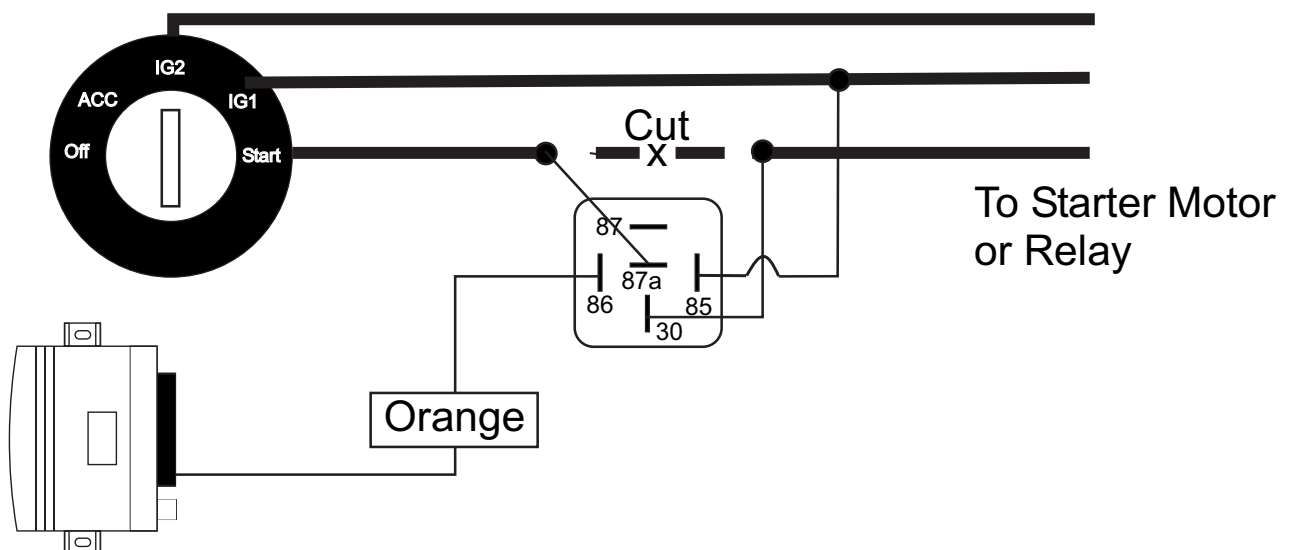

Free Manuals Download Website

<http://myh66.com>

<http://usermanuals.us>

<http://www.somanuals.com>

<http://www.4manuals.cc>

<http://www.manual-lib.com>

<http://www.404manual.com>

<http://www.luxmanual.com>

<http://aubethermostatmanual.com>

Golf course search by state

<http://golfingnear.com>

Email search by domain

<http://emailbydomain.com>

Auto manuals search

<http://auto.somanuals.com>

TV manuals search

<http://tv.somanuals.com>