

# MAGICARD



## Reverse Transfer

## ID Card Printer



User Guide

# Magicaard Prima Re-transfer Laminating Printer



- Thankyou for purchasing this product
- **Please read this manual carefully** before use to ensure correct operation. **It is particularly important to read the Safety Precautions** for safe operation. After reading, retain this manual carefully for future reference
- The product number is important for quality control. Upon purchase, check the back of the unit to make sure that the product number is correctly displayed.

## Notes about this manual

- (1) This manual may not be reprinted in any way without permission
- (2) The contents of this manual, as well as the specifications and design of this product, may change without notice.
- (3) The illustrations used in this manual may differ slightly from the actual product.

### Connection

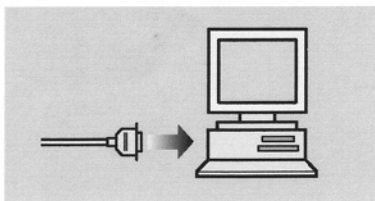

See p.10~13

### Ink replacement

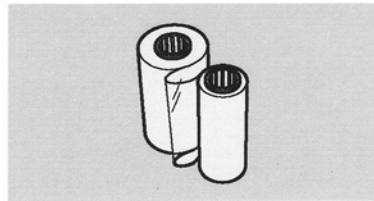

See p.14~18

### Setting the cards

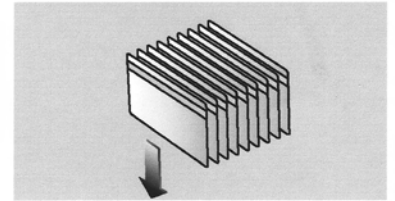

See p.18~21

### Setting the various modes

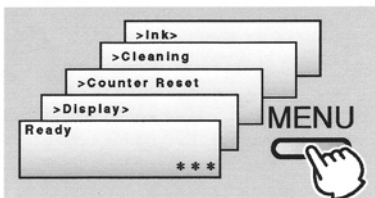

See p.29~34

### Care

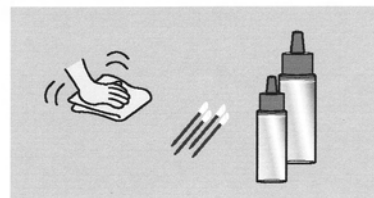

See p.35~39

### Error codes

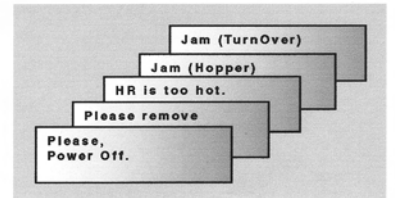

See p.40~43

---

## Declaration of Conformity

Model Number:           IDX380yyyyyy(y=A-Z,0-9 or blank)

Product name:            Card Printer

We herewith declare that the above mentioned product complies with the following council directives and harmonized standards.

Council Directives:      89/336/EEC relating to electromagnetic compatibility.  
                              73/23/EEC  relating to electrical equipment designed for use within  
  certain voltage limits.

Harmonized Standards:  EN55022:1998+A1 2000 Class B  
                                  EN55024:1998  
                                  EN61000-3-2:1995+A1:1998+A2:1998+A14:2000  
                                  EN61000-3-3:1995  
                                  EN60950:2000

Manufacture:

*Victor Data Systems Co., Ltd.*  
*1644, Shimotsuruma, Yamato-shi, Kanagawa-ken, 242-8514, Japan*

Importer and distributor:

*Digital Imaging International GmbH*  
*Buchenteich3, DE-73733 Aichwald Germany*  
*Tel.: (711)540 700, Fax: (711)540 70 555*

Year to begin affixing CE Marking: 2002

Yamato-shi, March.21.2002

Place,   Date



Tateki Hisanaga General Manager-Quality Control  
Victor Data Systems Co., Ltd.

---

## For USA only

**NOTE:** This equipment has been tested and found to comply with the limits for a Class A digital device, pursuant to Part 15 of the FCC Rules. These limits are designed to provide reasonable protection against harmful interference when the equipment is operated in a commercial environment. This equipment generates, uses, and can radiate radio frequency energy and, if not installed and used in accordance with the instruction manual, may cause harmful interference to radio communications.

Operation of this equipment in a residential area is likely to cause harmful interference in which case the user will be required to correct the interference at his own expense.

**CAUTION:** Changes or modifications not approved by party responsible for compliance could void user's authority to operate the equipment.

### Machine Noise

Sound power level: less than 70 dB (A) according to DIN45635 part 19 (EN27779).

The measurements are to be made according to DIN 45635 part 2019 or EN27779, respectively.

# Contents

<b>Before use</b> .....	<b>7</b>	<b>Operation</b> .....	<b>24</b>
Product features .....	7	Turning on the power .....	24
Checking accessories .....	7	Turning off the power .....	25
Handling of transfer film, ink ribbons and cards ....	7	About the RESET button .....	25
Handling .....	7	On Initialization when the retransfer film cassette	
Storage .....	7	and/or the ink ribbon cassette is loaded .....	25
Storing and handling cards after printing .....	8	User modes .....	26
Purchasing print media and cards .....	8	User mode screen flow .....	26
Installation .....	8	User mode settings .....	27
Installation diagram .....	8	Display mode settings .....	28
<b>Names of parts</b> .....	<b>9</b>	Clearing the free counter .....	29
Front .....	9	Cleaning mode .....	29
Rear .....	9	Ink mode setting .....	30
When the printer door is open .....	9	Retransfer mode setting .....	31
<b>Set-up</b> .....	<b>10</b>	Buzzer mode setting .....	32
Connecting with a host computer .....	10	Power saving mode settings .....	32
Connecting the IC unit (sold separately) .....	11	Setting the bend remedy mode .....	33
Large size IC unit (sold separately) .....	11	Card size setting mode .....	34
Compact IC unit (sold separately) .....	12	Antimagnetic setting mode .....	34
Connecting the power cord .....	12	Non-contact IC antenna setting mode .....	34
Installing the card stacker .....	13	IC contact setting mode .....	34
Discharging the card .....	13	Test print .....	34
Setting the ink ribbon .....	14	Transport mode .....	34
Setting the retransfer film .....	16	<b>Care and cleaning</b> .....	<b>35</b>
Caution when loading the retransfer film cassette		Cleaning the cleaning rollers .....	35
and/or the ink ribbon cassette .....	18	Cleaning the thermal head .....	36
Setting cards .....	18	Cleaning the fan filter .....	36
Inserting cards .....	19	Cleaning the fan filter on the back side .....	37
When using magnetic cards .....	20	Cleaning the card feed rollers .....	38
When using contact IC cards .....	20	Cleaning the card feed rollers and heat rollers ....	39
Loading cards .....	20	Once printer servicing and cleaning have been	
Switching the card thickness .....	21	completed .....	39
<b>Before use</b> .....	<b>22</b>	<b>Troubleshooting</b> .....	<b>40</b>
Names of parts on the operation panel .....	22	Layout of rollers inside the printer .....	40
Setting buttons .....	22	Error code listing .....	41
Operation display LED .....	22	Mending broken ink ribbon and retransfer film ....	43
LCD panel .....	22	About printing errors .....	43
Operation display LED contents and		Removing card jams .....	44
the LCD panel .....	23	Hopper jam .....	44
Initialization period .....	23	Turnover section [Jam (turnover)] .....	45
Preheating period .....	23	Retransfer section [Jam (transfer)] .....	45
LCD operation display content .....	23	<b>Specifications</b> .....	<b>46</b>
		Main specifications .....	46

# Notes for safe operation (to the next page)

## Before you use

Read these notes on safety thoroughly before operating your printer in order to use the unit properly. Once you start using the unit, this manual should be put aside the unit, or at a convenient place where you can look up the manual any time as you need.



### WARNING

- If you ignore the warning with this mark, and handle the unit in a wrong way, death or serious injuries may occur.



### CAUTION

- If you ignore the caution with this mark, and handle the unit in a wrong way, injuries or damages to properties may occur.



### WARNING

- **If the abnormal phenomena as listed below are seen, immediately stop operating the unit. Continuing operation may cause a fire or electric shock.**

- Smoke or odd smell comes out from the machine.
- Water or metal went into the machine.
- The unit fell to the floor, or the cabinet was broken.
- The power cable is damaged (exposed lead, broken cable, etc.)

If you see these phenomena, turn off the power, pull out the power plug, and contact your dealer as soon as possible. Do not try to repair it by yourself. It is dangerous.

- **Do not remove the screws, or disassemble or alter the machine.**

- High-voltage components are contained in the unit. Touching these areas may result in an electric shock.
- Ask your dealer if you want your printer inspected or repaired.
- Do not remove the external covers of the machine. You may get an electric shock.

- **Do not work on the power cable, or give excessive force on it. Do not put heavy objects such as furniture on the cable.**

- The cable may be damaged, causing a fire or electric shock.
- When you find a defect on the power cable, such as exposed lead, stop using the unit, and consult your dealer.

- **Do not use the machine with the power plug inserted incompletely.**

- The machine generates heat due to incomplete contact, causing a fire or electric shock.
- Do not put many cords on a single plug socket. The power cords also heats up.

- **Do not use the machine with dusts piled on the power plug. Do not put a metallic material adjacent to the power plug.**

- Dusts and metal are conductive, causing a fire or electric shock.
- Pull out the power plug from the outlet every six months, and clean the dusts piled on the legs and body of the plug.

- **Do not use a line voltage other than instructed.**

- Using a line voltage or power supply which is not specified may cause a fire or electric shock.

- **Do not put foreign materials from the openings of the machine (e.g., vents, card slots, cassette inlet, etc.)**

- Metals, flammable things, and other foreign materials may cause a fire or electric shock if entering into the machine.
- If these things went into the machine, immediately turn off the power, pull out the power plug, and ask your dealer to repair. Do not try to repair it by yourself. It is dangerous.

- **Do not put a container with liquid in it, or small metal ornaments and the like on the machine.**

- The liquid or metal entering into the machine acts as a conductor, causing a fire or electric shock.
- If liquid or metal went into the machine, immediately turn off the power, pull out the power plug, and ask your dealer to repair. Do not try to repair it by yourself. It is dangerous.

- **Do not place the machine on a rickety table or slanting places.**

- The machine may fall out of the table or fall over, which may damage the machine or injure you.
- If the machine is damaged by falling or turnover, immediately turn off the power, pull out the power plug, and ask your dealer to repair. Do not try to repair it by yourself. It is dangerous.

- **Do not wet the machine with water.**

- Using the machine at a place where water splashes on the machine, or wetting the machine with water (applying, throwing, or spilling water over the machine) may cause a fire or electric shock.
- If water entered into the machine, immediately turn off the power, pull out the power plug, and ask your dealer to repair. Do not try to repair it by yourself. It is dangerous.

- **Do not touch the machine with wet hands.**

- Touching the machine with wet hands may cause an electric shock.

- **Do not touch the power plug during electrical storms.**

- Lightning may cause an electric shock.

# Notes for safe operation (continued)

## ■ Ground the machine with the attached electric cord when connecting it to the utility outlet.

- Using a cord other than the one supplied for grounding may cause an electric shock when the machine fails.

## ■ Do not put your head or yourself into the packaging bag.

- Do not play with the packaging bag. You may suffocate yourself.
- Give close attention to small children who may want to play with the packaging bag.

## ■ Do not use the machine while it has a fault.

- Do not use the machine while it has a fault, as this may cause a fire or electric shock.
- Immediately turn off the power, pull out the power plug, and ask your dealer to repair. Do not try to repair it by yourself. It is dangerous.



## CAUTION

## ■ Pull out the power plug before cleaning the machine.

- This is for preventing electric shocks.

## ■ Pull out the power plug when you won't use the machine for a prolonged period of time to assure safety.

- Remove the power plug from the outlet for safety when you won't use the machine for a long time.

## ■ Do not move the machine with the power cable and other electric cables connected.

- The cables may be damaged while being moved, which may cause a fire or electric shock.
- You may stumble over the cable and get injured.

## ■ Do not move the machine with objects placed on it.

- They may fall on you and hurt you.

## ■ Do not put heavy objects on the machine.

- They may fall on you and hurt you.

## ■ Do not block the vents.

- Heat generated inside the machine cannot escape, which may cause a fire.

## ■ Be sure to work with two persons when you unpack, move or lift the machine.

- If you work alone, you may be injured by the fallen machine or hurt your back by lifting a heavy machine by yourself.

## ■ Inspection

- Ask your dealer or a qualified person to inspect the machine, typically once every two to three years. Operating the machine with dusts piling on the components for a prolonged period of time may cause a fire or a malfunction of the machine. It will be particularly effective to inspect the machine before wet rainy season. Consult your dealer on the costs of inspection.

## ■ Do not put the machine at a place where it will be wet with steam (e.g., from a humidifier), or at a excessively humid or dusty place.

- The oil, water and dusts act as conductors, which may cause a fire or electric shock.

## ■ Do not put the machine at a place where it becomes excessively hot.

- The surface and internal components may deteriorate. Also there is a danger of a fire. Special care should be taken for exposure to direct sunlight or a heater adjacent to the machine.

## ■ Hold the body of the power plug when pulling it out.

- Do not pull out the plug by holding the cable. The cable may be broken or damaged which may in turn cause a fire or electric shock.

## ■ Do not touch the power plug with a wet hand

- You may get an electric shock.

## ■ Do not lay the power cable near the heating equipment.

- The covering of the cable will melt due to heat from such equipment, which may cause a fire or electric shock.

## ■ The heat rollers and adjacent areas become hot during operation.

- Be careful not to touch the heat rollers and adjacent areas when replacing the ink ribbon or retransfer film, or remove jammed cards.
- Wait until the heat rollers get cooled down to prevent burns.

## ■ Be careful of jamming your hand or fingers in the card tray, card bracket on the hopper, or printer door.

- Replace the ink ribbon or retransfer film, or remove jammed cards with care not to jam your hand or fingers in the mechanism, which may cause an injury.

## ■ Do not use a power cable other than the specified cable for connection.

- If you use an unspecified power cable for connection or extension, heat may accumulate in the cable, causing a fire.

## Product features

- This card printer allows printing of high-quality, full-color images equivalent to photographic quality onto standard size (ISO 7810 compliance) plastic cards using sublimation type transfer printing.
- Use of sublimation type retransfer printing enables printing of cards other than those made of PVC and non-contact IC cards, etc. with uneven surfaces that were previously difficult to print directly.  
(Some card materials may not be suitable for printing. Consult your dealer regarding the materials to be used and specifications required before purchase.)
- Printing with no margins on all sides is possible.
- The host interface utilizes SCSI (asynchronous) mode. The unit has a built-in SCSI bus terminator.

## Checking accessories

Please check for any missing accessories when opening the box.

- Power cord: AC120V type: ..... 1 unit  
(For North America)  
AC220V-240V cord: ..... 1 unit  
(For Europe)
- Cleaning card : 1 unit
- Card stacker : 1 unit
- Instruction manual : English ..... 1 unit
- Ink ribbon cassette : 1 unit
- Retransfer film : 1 unit  
cassette
- Ferrite core : 2 units  
(Standard model : 1 unit,  
built-in IC encoder model : 2  
units)
- Binder(for securing : 4 units  
the ferrite core) (Standard model : 2 units,  
built-in IC encoder model : 4  
units)
- Jog lever (inside the card tray)  
: 1 unit

## Handling of transfer film, ink ribbons and cards

### Handling

Take note of the following points when handling print media (retransfer film and ink ribbons) and cards.

- **Use of bent or damaged cards may result in card feed error.**
- **Do not touch the print media or the printed surface of cards directly with the hands as this may cause blurring of the print.**
- **Foreign materials on the printing area may result in misprints. Always load the print media and cards in a clean environment.**
- **Static build-up in the print media or cards can cause errors. To avoid causing static electricity, do not rub cards together.**
- **When replacing or replenishing print media or cards that have been stored at low temperatures, let the print media or cards sit for at least one hour at the same temperature as location where the printer is to be used before use. Using print media or cards as they are may cause condensation and result in malfunction or print errors.**

### Storage

The storage condition of the print media (retransfer film and ink ribbons) and cards may have a strong influence on the print quality. Select a storage location that fits the following criteria:

#### Storage environment

Storage temperature : 5°C to 25°C  
Storage environment relative humidity : 40% to 60%

#### Storage location

To avoid deterioration of the print media, do not store in the following locations:

- **Locations exposed to direct sunlight**
- **Locations with high humidity**
- **Locations near organic solvents or diazo copiers.**

#### Storage period

Use within one year.



# Before use (continued)

## Storing and handling cards after printing

Avoid storing the cards in locations exposed to direct sunlight or with high humidity.

Furthermore, avoid contact with the following chemicals and stationery, as they can cause discoloration or fading of the cards:

- **Organic solvents such as alcohol, film cleaner, diazo copies, etc.**
- **Soft vinyl chlorides, document cases, pass holders, erasers, etc.**
- **Hair-dressing products and cosmetics, etc.**

## Purchasing print media and cards

Contact your dealer regarding the purchase of print media (retransfer film and ink ribbons) and cards. Always use the products specified below.

### Print media

Use only the ink ribbons and retransfer film specified for this unit. For the names of these products refer to "Main Specifications" on p. 46 of this manual.



### CAUTION

We can accept no liability for any problems arising as a result of the use of media using materials other than those specified.

### Card material

- ISO/IEC 7810 type ID1 (dimensions) : equivalent product
- ISO/IEC 7811-2 (Magnetic stripe) : equivalent product
- ISO/IEC 7816 (IC card) : equivalent product

The materials of some cards may not be suitable for printing. Consult your dealer regarding the materials to be used and specifications required before purchase.

## Installation

The performance of the card printer is strongly influenced by the installation location. Do not install in the following kinds of location:

- **Dusty locations**  
Use the card printer in clean locations such as general offices where no problems are encountered using computers. Using the printer in dusty locations can cause blurrings of the print and printing head malfunctions. Avoid the following kinds of location:
- **Locations susceptible to strong vibration or shock**
- **Locations exposed to direct sunlight**
- **Locations where there is a possibility of metal objects and other foreign material entering the unit**
- **Areas near walls with little ventilation**
- **Unstable locations and angled surfaces**
- **Locations prone to static electricity, such as a carpeted room**
- **Areas near air conditioners, humidifiers, stoves, etc. that may cause condensation within the printer**

The printer is to be installed in an environment with the following temperature and humidity.

Temperature : 15°C to 30°C

Humidity : 35% to 70%



### CAUTION

Use of the printer in an environment with temperatures lower than the above range may cause retransfer errors and use of the printer in an environment with temperatures higher than the above range may cause print errors from deformation of the cards and wrinkling of the film.

## Installation diagram

Ventilation holes are provided for the cooling fan on the bottom and sides of the unit. Avoid inserting any object into the gap between the bottom of the unit and the top of the stand. Install the unit with its sides kept away from the surrounding wall as illustrated in the diagram, and keep the back of the unit at least 10cm away from the wall. Also, do not place any object on top of the unit.

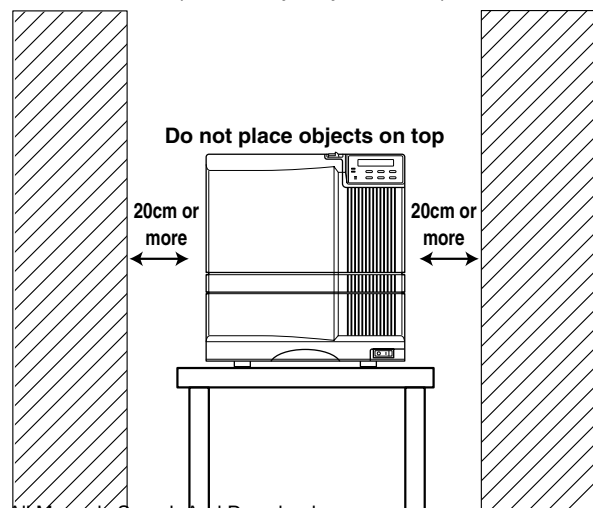

# Names of parts

Front

When the printer door is open

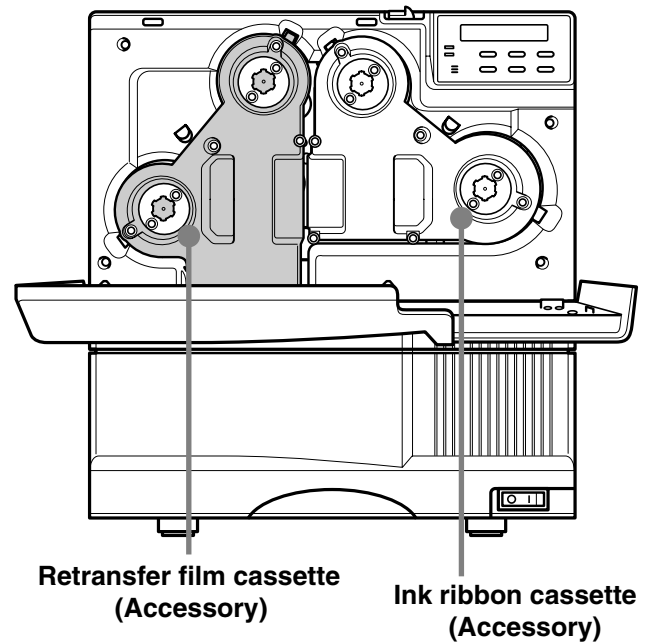
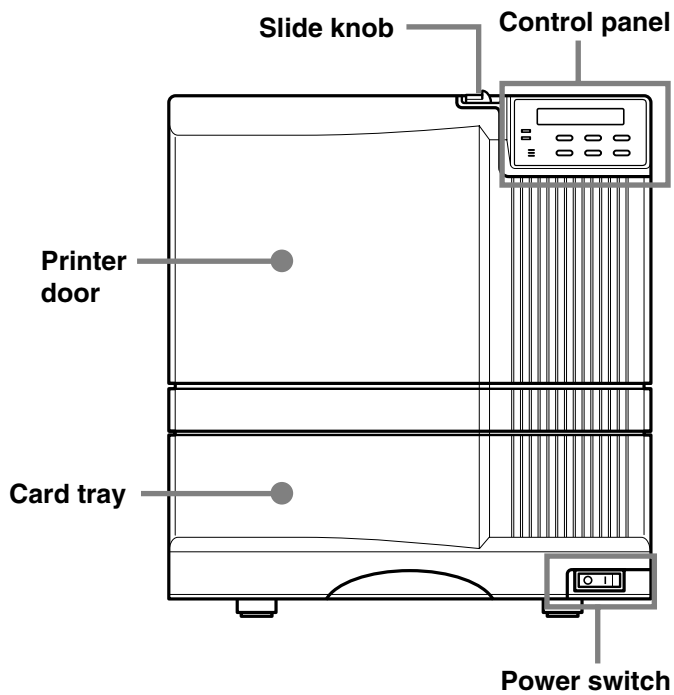

Rear

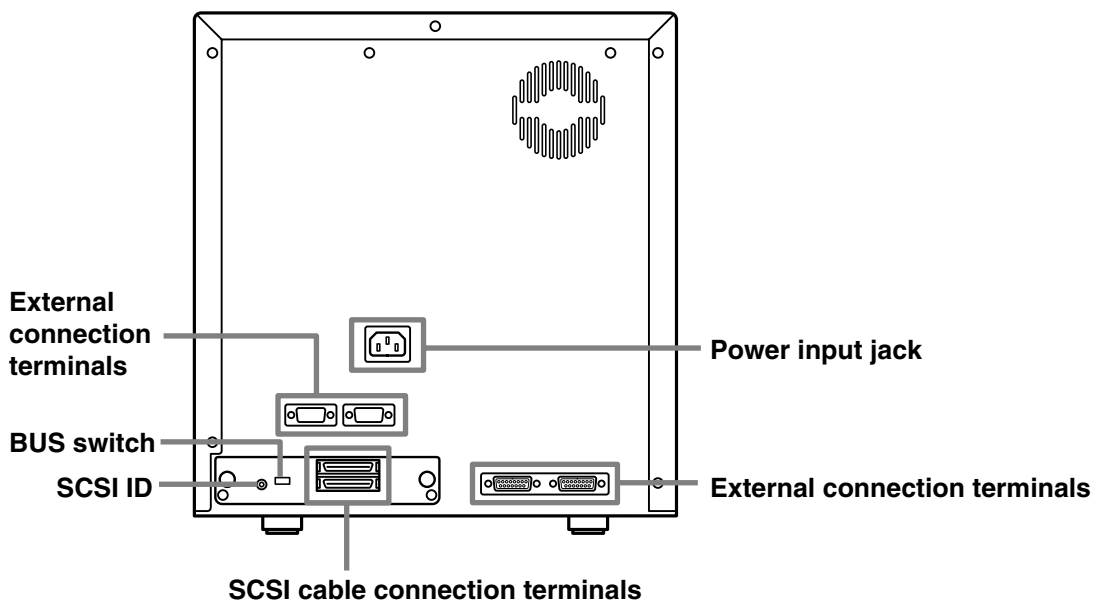

# Set-up

## Connecting with a host computer

This section describes the settings for connection with a host computer.



### CAUTION

Make sure that the power switch is switched to OFF when connecting with a host computer or making settings.

### 1. Set the BUS switches.

Set the BUS switches on the rear according to the usage environment.

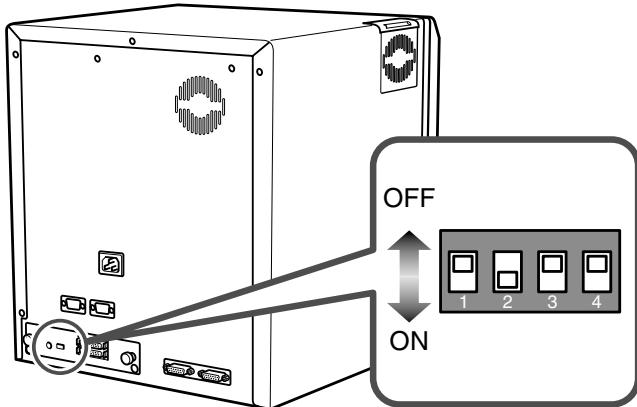

A screwdriver or similar tools is required for changing the switch settings.

bit1: Parity check	ON/OFF
bit2: Termination	ON/OFF
bit3: Not in use (OFF)	
bit4: Not in use (OFF)	

#### Parity check switch (factory setting: OFF)

Used to set the parity switch feature.

ON: Parity check activated

OFF: Parity check inactivated

#### Termination switch (factory setting: ON)

Set the termination switch to ON when using the unit as an end device.

### 2. Set the SCSI ID.

Set the SCSI ID switch on the rear of the unit according to the usage environment (ID 0 – 7). (The factory setting is ID 0.)

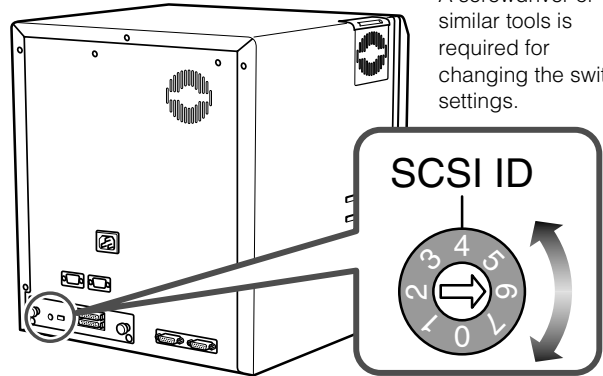

A screwdriver or similar tools is required for changing the switch settings.



### CAUTION

Make sure that there are no other devices with the same ID connected to the host computer, because this may cause a malfunction of the entire system.

### 3. Connect the interface cable.

Connect to the host computer by connecting the interface cable to the SCSI cable connection terminal on the rear of the unit. Connect the interface cable to the SCSI cable connection terminal on the rear of the unit, then secure the ferrite core close to the SCSI cable connection terminal.

Connect to either the SERIAL1 or 2 terminals

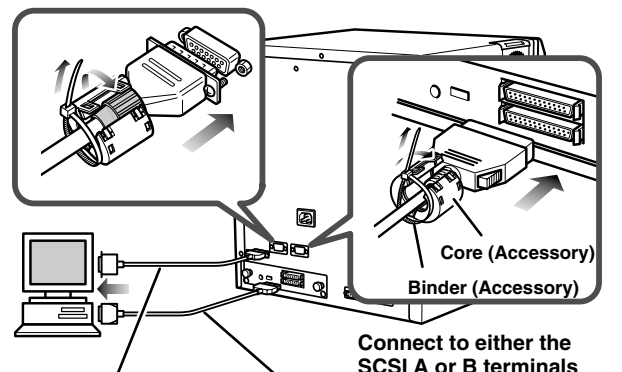

Connection cable  
(Commercially available)

Interface cable (Commercially available)

Connect to either the  
SCSI A or B terminals

- Both SCSI A and SCSI B can be used.
- Connect contact-IC encoder cables, which are commercially available to the SERIAL1 and 2 terminals. Consult your dealer regarding the details of the cables.



### CAUTION

Make sure to secure the filter ferrite core close to the SCSI cable connection terminal. Otherwise it does not take effect.

## Connecting the IC unit (sold separately)

Large and compact size IC units are sold separately, as are specialized optional devices for the unit. Consult your dealer for more details.

### **WARNING**



Electric shock

- Make sure that the power switch is turned OFF and the AC cable is detached from the plug, before connecting and disconnecting the IC units. Otherwise electric shocks, fires or malfunction of the product may occur.
- Using IC units other than those specified may cause electric shocks, fires or malfunction of the product.

### Large size IC unit (sold separately)

- 1.** A joint plate for an IC unit is provided as an accessory.

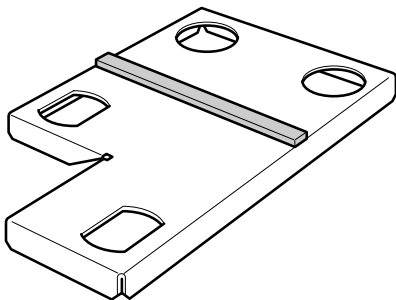

- 2.** Fit the printer and IC unit into the holes as shown.

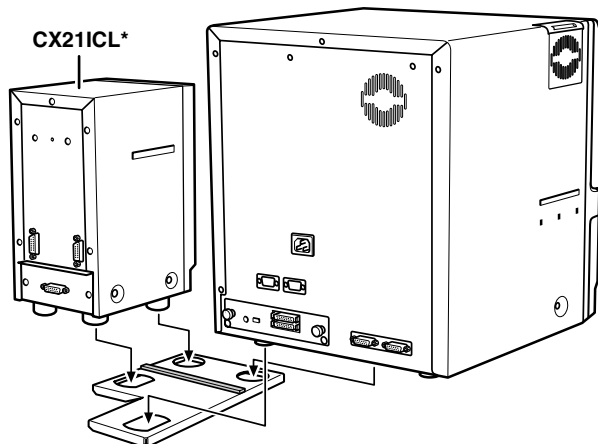

CX211CL\* is manufactured by Victor Data Systems Company of Japan, Limited.



### **CAUTION**

Unstable locations and angled surfaces may cause card feeder malfunctions. Make sure to fit the devices into the holes securely. Furthermore, install the printer on a flat and hard surface.

- 3.** Connect the printer and IC unit.

Connect the cable which comes with the IC unit to the OPTION 1 terminal.

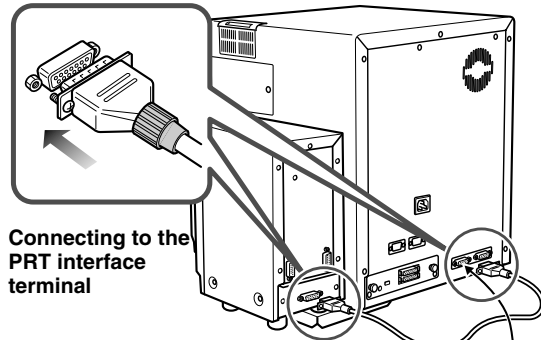

Connecting to the PRT interface terminal

Connection cable (Accessory)

Use the OPTION 1 side.  
If you use side 2 it does not function.

- 4.** Connect the IC unit with the host computer.

Connect interface cables which are commercially available.

The terminal is rotated 180°

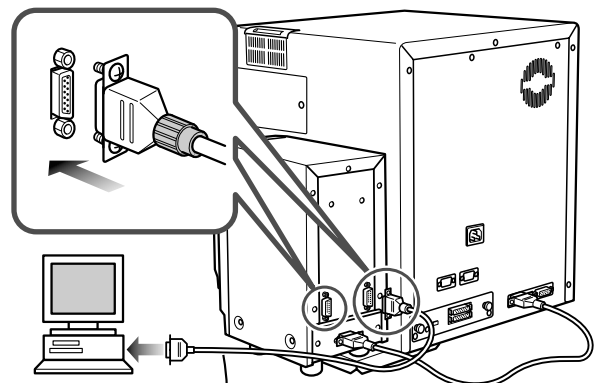

Commercial item

Terminals on the rear of the IC unit SERIAL1:non-contact  
SERIAL2:contact

# Set-up (continued)

## Compact IC unit (sold separately)

Please ask your dealer for the Compact IC unit connection.

### 1. Connect the compact IC unit to the host computer.

Connect interface cables which are commercially available.

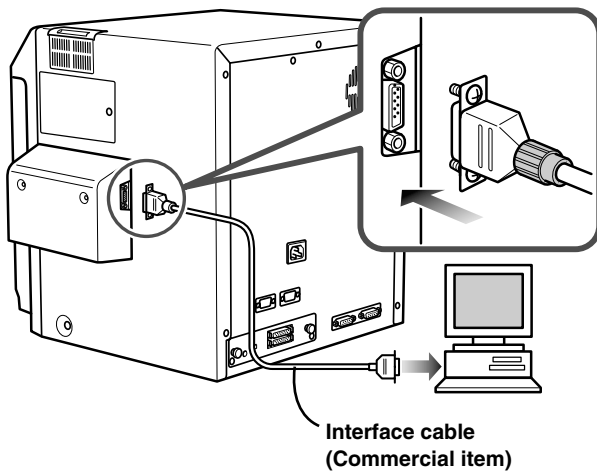

## Connecting the power cord

### 1. Check the plug.

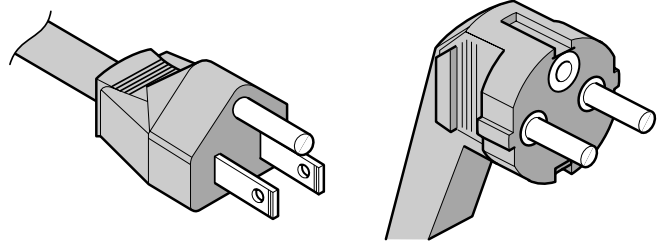

● Dark gray  
For AC 120V type  
(North America)

● For AC220-240V type  
(Europe)

### 2. Plug the power cable into the printer.

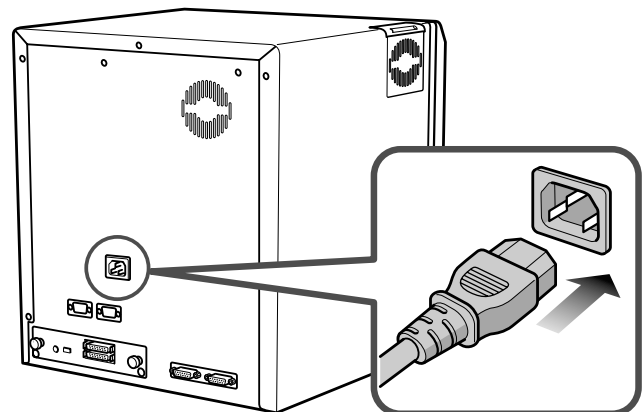

#### CAUTION

Always use a grounded power outlet. Never share the outlet with other electrical equipment.

Use an AVR (Automatic Voltage Regulator) if there is a possibility of voltage fluctuation. Use an uninterruptible power source rather than an AVR if there is the possibility of uninterruptible power source.

## Installing the card stacker

### 1. Mount the card stacker on the printer.

Hang the stacker claw on the stacker receptacle.

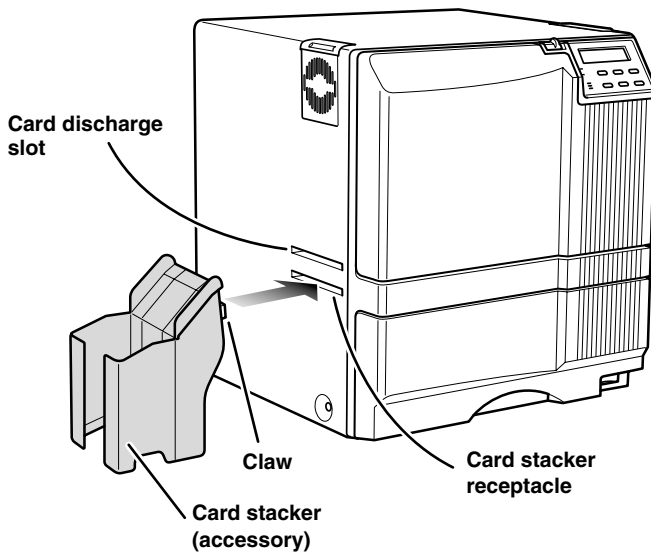

The card stacker is capable of containing approximately 100 0.76mm-thick cards or 280 0.25mm-thick cards at the maximum.



#### CAUTION

Be sure to hang the card stacker claw on the card stacker receptacle, not the card discharge slot. If you mount the card stacker at a wrong place, cards are not discharged, resulting in a card jam.

## Discharging the card

When correctly printed, the cards are discharged from the left side.

If a card jam or a write error on magnetic stripes occurs on the way, results differ depending on the areas.

**Portion A:** If a card jam or a write error on magnetic stripes occurs on the way, press the RESET button, then the ENTER button. The printer is initialized, and the cards are discharged from the right side of the printer.

**Portion B:** See the description in Jam (Transfer) on p.45.

**Portion C:** When correctly printed, the cards are discharged from the left side of the printer. The cards jamming around this area are also discharged from the left side.

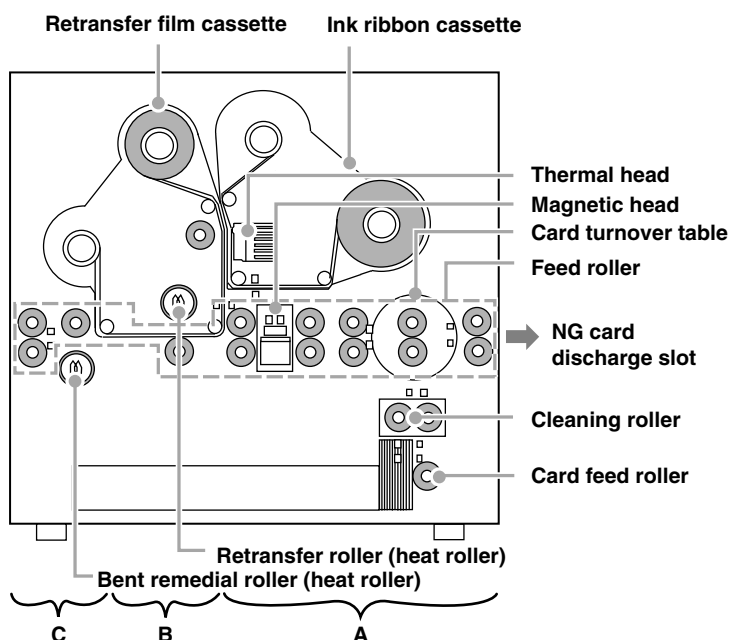

# Set-up (continued)

## Setting the ink ribbon



### CAUTION

Do not touch the surface of the ribbon with your hands.

### 1. Activate the slide knob and open the printer door.

When the slide knob is moved, the printer door opens downwards. Hold the door with your hand and open it slowly.

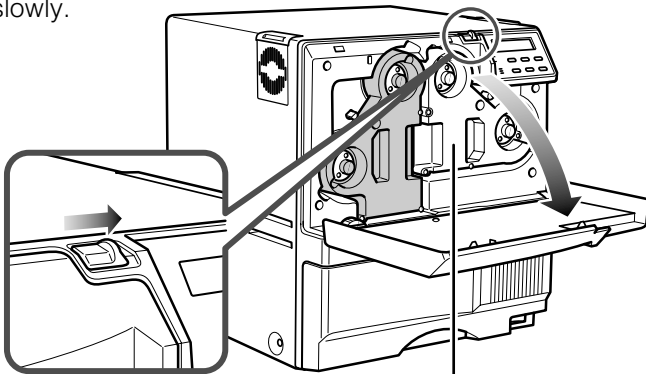

Ink ribbon cassette (yellow)



### CAUTION

Do not put the ink ribbon or retransfer film on the back of the door for mounting. Do not rest your elbows or put a heavy thing on the back of the door. The printer door may be broken.

### 2. Remove the ink ribbon cassette.

When the lever is pressed, a small portion of the cassette pops out.

Cushion

Press the removal lever.

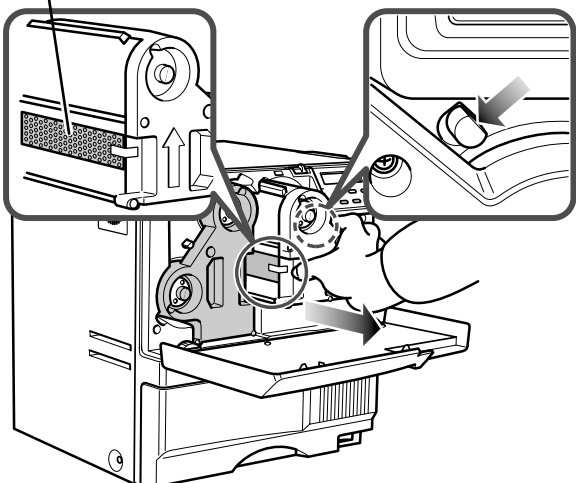

### CAUTION

When transporting the unit, remove the ink ribbon and the retransfer film, then place the cushion on the thermal head. Transporting without the cushion may cause the thermal head and roller to malfunction. Do not use cushion materials other than the transfer cushion that comes with the unit, as this may cause damage to the head.

### 3. Insert the ink ribbon into the cassette.

Stretch the ink ribbon along three shafts with the ink face of the ribbon facing outside and insert the bobbins firmly into the bobbin holders.

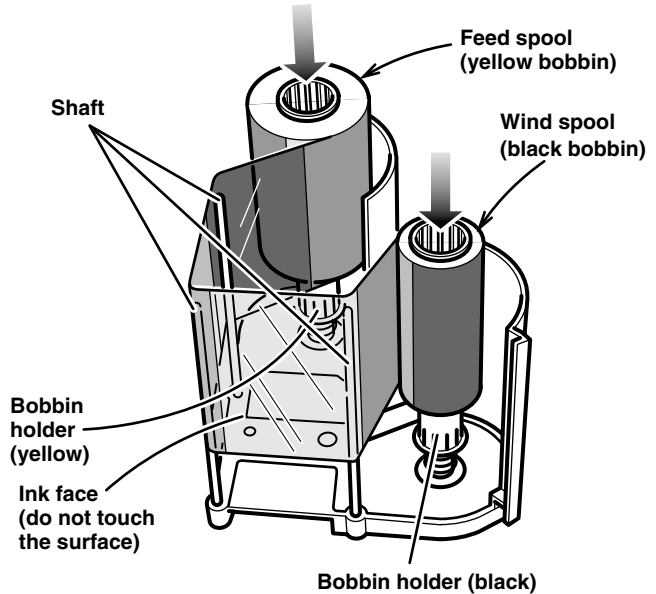

Place the cassette upright on a flat surface during set-up.



### CAUTION

When you need to take out the cassette, for instance, to clean the printer, be sure to put the cassette upright as shown in the above illustration. When the ink ribbon is put on the table with its face down, dusts attach to the surface, causing a malfunction of the printer.

### 4. Wind the ribbon, taking up the slack.

Turn the knob in the arrow direction to wind a small portion of the ink ribbon. If the ink ribbon does not wind up, go back to step 3, and insert the ink ribbon firmly into the bobbin holders.

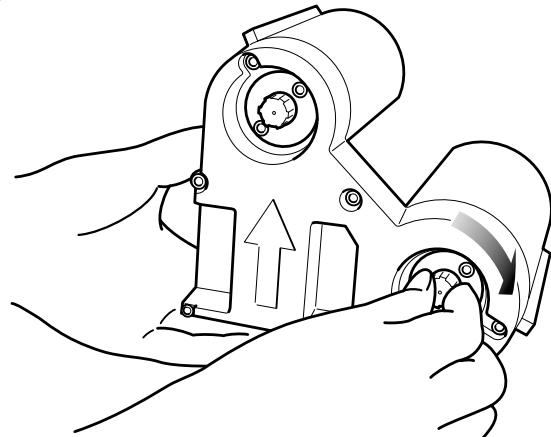

### CAUTION

If the ink ribbon is not tightly wound, the slack may cause the ribbon to be caught in the parts of the printer when you set the cassette, or the card to be printed in uneven colors.

## 5. Insert the cassette along the guide rail.

Insert the cassette until it clicks securely into position. The lever returns to its original position.

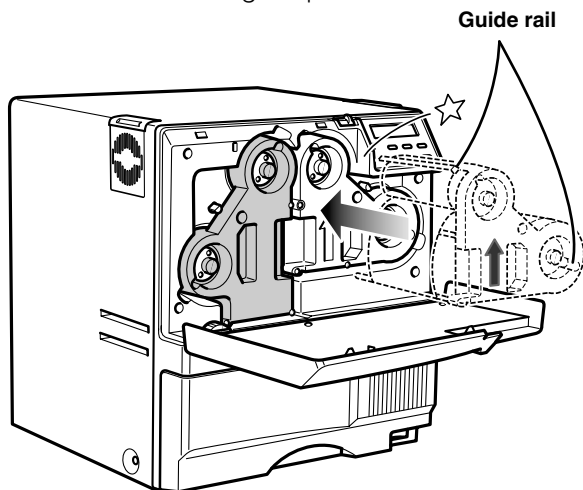

### CAUTION

- The cassette containing the ink ribbon is heavy. Hold the cassette with both hands when you set or take out the cassette.
- If the cassette unit is not set properly into position before printing, horizontal lines may be printed with the image.

## 6. Close the printer door.

If you want to mount the retransfer film, keep the door open and go to the next page.

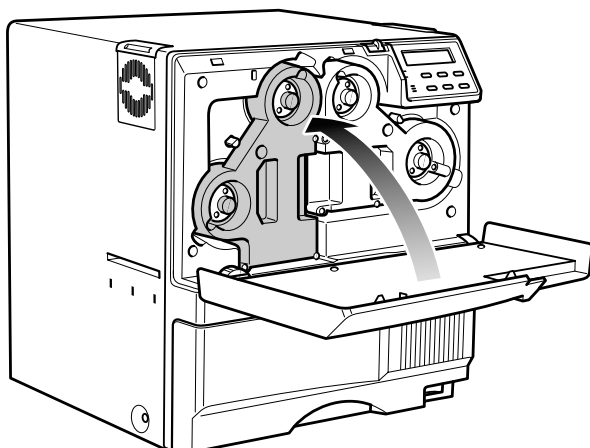

### Memo

When the ink ribbon is wound up to the end,

**Ink Run Out**

appears on the LCD panel.

After replacement press the RESET button, then press the ENTER button.

If the ink ribbon is not set properly,

**Ink Search**

or

**Ink Broken**

appears on the LCD panel. When these messages are output, check:

- The ink ribbon is firmly inserted into the bobbin holders.
- The ink face of the ribbon is directed correctly.
- The feeding and winding bobbins are mounted correctly.



### Memo

To mount the ink ribbon which is partially used, set the unused portion of the ribbon (yellow bobbin) on the bobbin holder indicated with an arrow on the seal of the cassette.

Printing with the ink ribbon set improperly may cause the image to be faint.



# Set-up (continued)

## Setting the retransfer film



### CAUTION

Do not touch the retransfer film surface with your hands.

### 1. Activate the slide knob and open the printer door.

When the slide knob is moved, the door opens downwards. Hold the door with your hand and open it slowly.

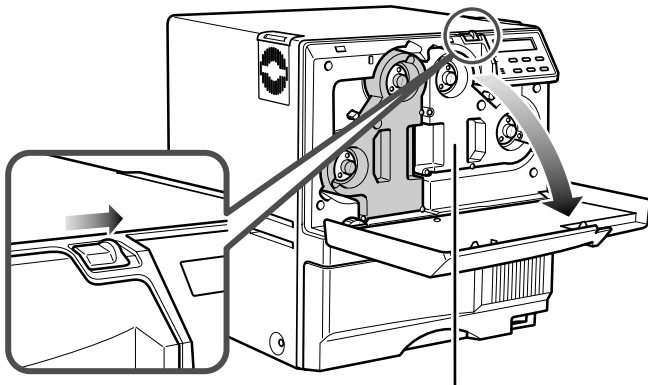

Retransfer film cassette (green)



### CAUTION

Do not put the ink ribbon or retransfer film on the back of the door for mounting. Do not rest your elbows or put any heavy object on the back of the door as it may break.

### 2. Remove the retransfer film cassette.

When you press the lever, a small portion of the cassette pops out.

Press the cassette removal lever.

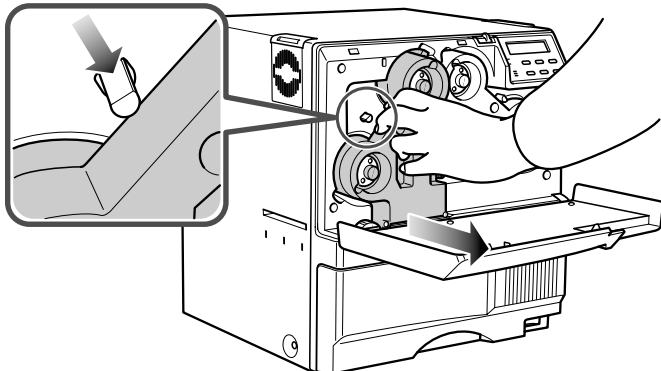

### 3. Insert the retransfer film into the cassette.

Stretch the retransfer film along three shafts with the retransfer face of the film facing outside and insert the bobbins into the bobbin holders firmly.

**At this time, perform setting so that the film is inside the guide. Make sure to wind the film on to the wind spool for more than two frames.**

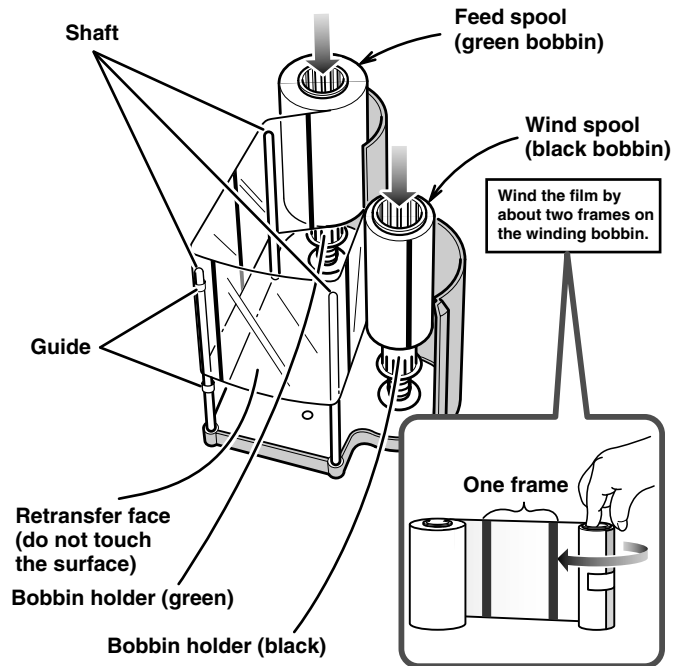

Place the cassette upright on a flat surface during set-up.



### CAUTION

When you need to take out the cassette, for instance, to clean the printer, be sure to put it upright as shown in the above illustration. When the film is put on the table with its retransfer face down, dusts attach to the surface, causing a failure of the printer.

#### 4. Wind the retransfer film to take up the slack.

Turn the knob in the arrow direction to wind a small portion of the retransfer film. If the film does not wind up, go back to step 3, and insert the bobbins firmly into the bobbin holders.

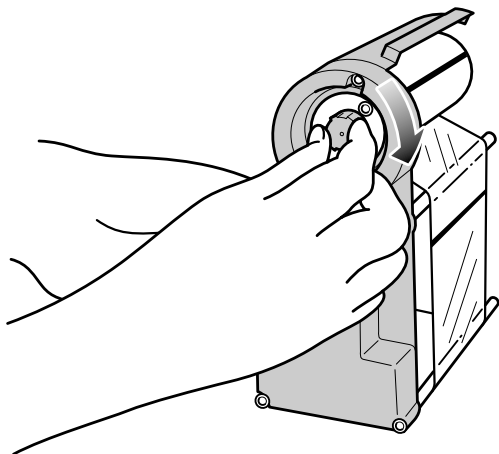

#### CAUTION

If the film is not tightly wound, the slack may cause the film to be caught in the parts of the printer when you set the cassette, or damaged due to wrinkles on the film. At this time, do not hold the film to remove slack. Winding deviation causes operation errors or defective prints.

#### 5. Open the printer door and insert the cassette.

Insert the cassette until it clicks securely into position. The lever returns to its original position.

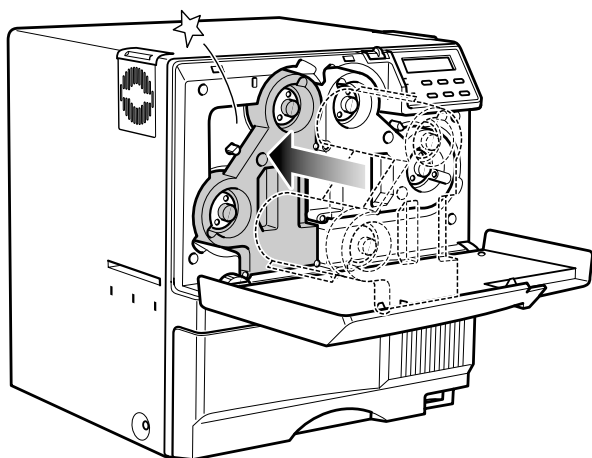

#### CAUTION

The cassette containing the retransfer film is heavy. Hold the cassette with both hands when you set or take out the cassette.

#### 6. Setting the number of frames to be used.

The number of frames of the retransfer film being used is set.

For details, refer to the "Media Type" setting on page 31.

This work must be done when the used film (number of frames) is changed.



#### CAUTION

When the number of frames is not changed, the entire picture after printing may be shifted.

#### 7. Close the printer door.



#### Memo

When the retransfer film is wound up to the end,

Media Run Out

appears on the LCD panel.

After replacement press the RESET button, then press the ENTER button.

If the retransfer film is not set properly,

Media Search

or

Media Broken

appears on the LCD panel. When these messages are output, check:

- The retransfer film is firmly inserted into the bobbin holders.
- The retransfer face of the film is directed correctly.
- The feeding and winding bobbins are mounted correctly.



#### Memo

To mount the retransfer film which is partially used, set the unused portion of the film on the bobbin holder indicated with an arrow on the seal of the cassette.

Printing with the transfer film set improperly may cause the image to be faint.

## Set-up (continued)

### Caution when loading the retransfer film cassette and/or the ink ribbon cassette

This describes the caution when the retransfer film cassette and/or the ink ribbon cassette is removed because of card jam or other trouble.

Please pay enough attention so that the retransfer film and/or ink ribbon is maintained at the right position. Particularly, the ink ribbon is extremely thin, therefore it apt to slip down when the cassette is removed as shown in the illustration.

#### Improper Winding

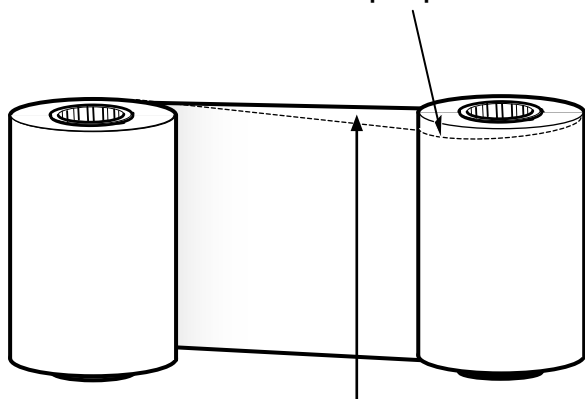

Adjust the position with hands so that the media position of take-up side and supply side becomes parallel

When loaded in this condition, it may cause improper printing such as INK RUNOUT error, improper color printing etc.

To avoid this, please handle the ink ribbon and/or the retransfer film very carefully with hands so that the media position of take-up side become parallel. Please do not touch the print side of the ink ribbon and/or the retransfer film with your hands. Otherwise, it may cause improper printing.

When adjusting the print position of the retransfer film and/or ink ribbon, please follow the instruction label attached on the cassettes.

### Setting cards

Please use cards specified by your dealer. This unit can take both 0.76 mm-thick and 0.25 mm-thick cards. The factory setting is for 0.76 mm-thickness. See p.21 to set the thickness switching plate to 0.25 when using 0.25 mm cards.



#### CAUTION

Fingerprints, soiling, etc. on card surface can result in print errors. Wear lint-free gloves when handling.

#### 1. Open the card tray.

Hold the lower part of the card tray and pull the tray toward you slowly until it no longer moves.

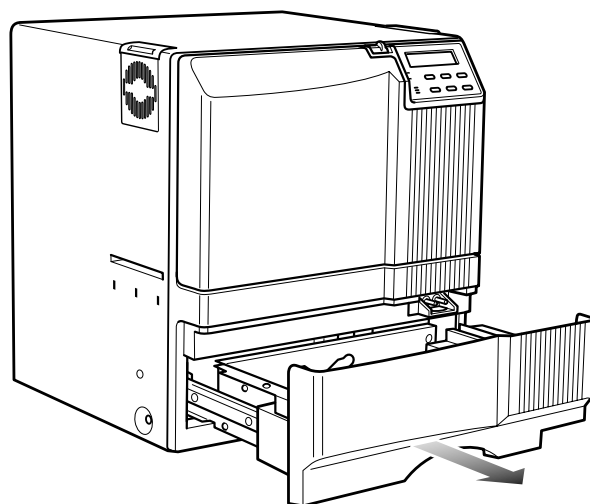

## Inserting cards

The unit can take about 300 0.76mm-thick cards.



### CAUTION

When removing new cards from the box, it is possible that cards may be stuck due to static electricity. In this case, peel the cards off one at a time before setting into position. Hold the edges of the card when carrying out these operations.

### 1. Pull the card bracket back.

The card bracket locks when it reaches the hole.

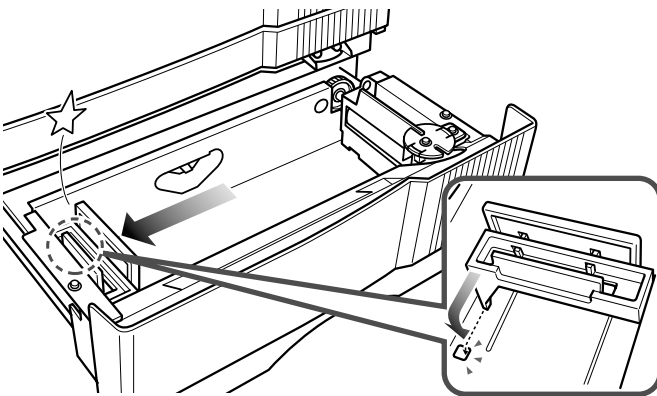

### 2. Insert the cards and move the bracket back into position.

Limit the number of cards as the card bracket moves back slightly from the lock position.



### CAUTION

Setting the cards improperly can cause feed jams. Check that the cards are neatly arranged.

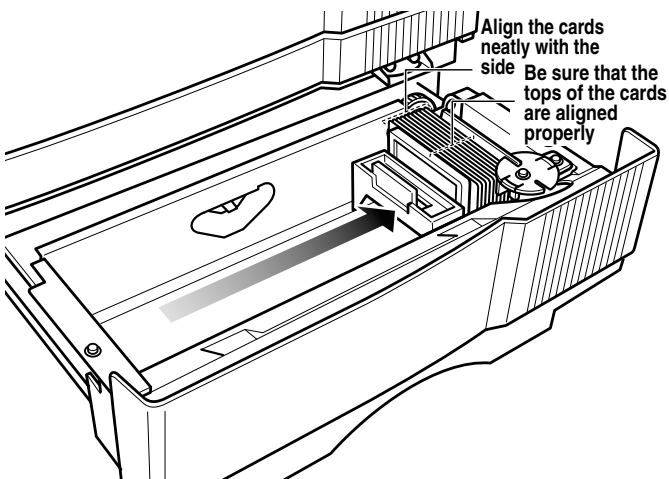

### CAUTION

When moving the card bracket back into position, do this slowly to avoid jamming your fingers. Leaving the card bracket out of position may cause card jams.

### 3. Close the card tray.

Push the card tray back into the printer until it no longer moves.

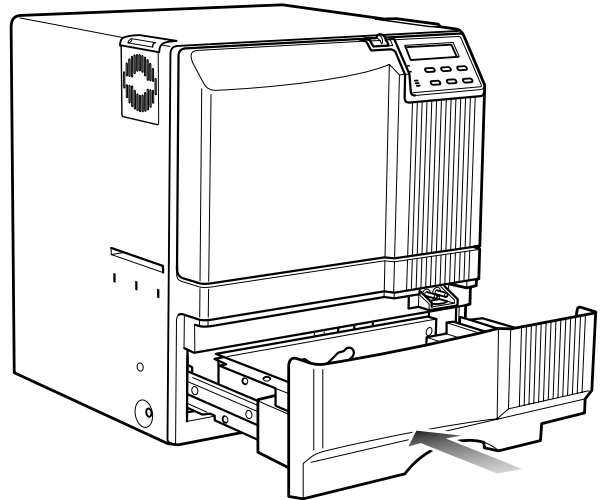

### Memo

To print pre-printed cards on this printer, set the cards as indicated on the Software Operation Manual of the host computer.



### CAUTION

When a magnetic or IC card is pre-printed in a dark color such as black, errors in positioning may occur during encoding. Consult your dealer on this issue before printing pre-printed cards.

# Set-up (continued)

## When using magnetic cards

When using cards with magnetic strips, set the cards in the following manner.

### For JIS II cards:

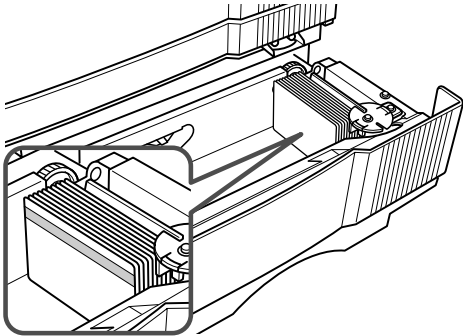

Place the card with its magnetic stripes **upward** and facing the card bracket.

### For ISO cards:

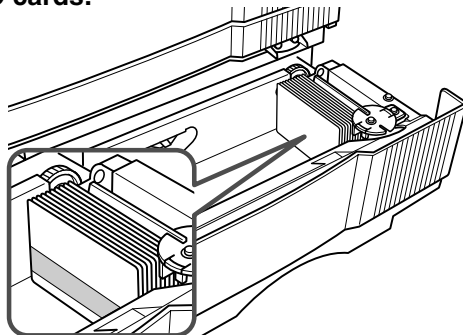

Place the card with its magnetic stripes **downward** and facing the card bracket.



### CAUTION

Printing on cards with magnetic strips is not guaranteed.

## When using contact IC cards

When using contact IC cards, set in the following manner.

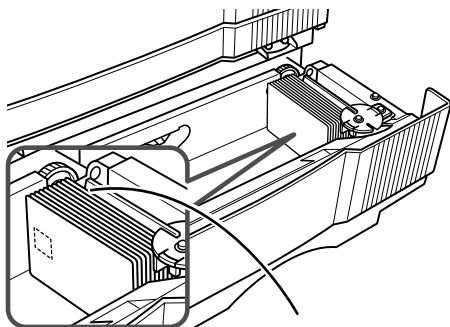

Place the IC card with its IC terminal inward and facing the card bracket.

## Loading cards

Load cards when the printer's LCD shows the message "Ready" or "No Card," etc. and not when printer operations have stopped due to an error. Cards can also be loaded when the power supply is not switched on. If there is a drop in the volume of remaining cards (under 20 cards with a thickness of 0.76mm), the electronic beep sounds before every feeding.

Ready

\*\*\*

OR

No Card

Loading

During printing, if there is a drop in the volume of remaining cards (under 20 cards with a thickness of 76mm) an electronic beep sounds.

When "Loading" is displayed on the LCD, **do not open the card tray under any circumstances.**

The unit is currently feeding cards. If a message other than the one above is displayed, cards can be loaded even while the unit is printing. However, you are recommended to load cards when the unit is not printing.

To prevent defective printing caused by suspended printing or vibration as a result of opening and closing the card tray, load cards with care.

## Switching the card thickness

Depending on the material, some 0.25mm thick cards may not be suitable for printing. Consult your dealer regarding the materials and specifications of the card before purchasing.

### WARNING



Electric shock

- Before switching the thickness, turn off the printer and the devices connecting to the printer, and take off their power plugs from the outlet to prevent an electric shock.

### CAUTION



Injury

- When switching the card thickness, be careful not to remove the screws except those instructed. Removing uninstructed screws may cause injuries or a malfunction of the printer.

## 1. Remove the blue securing screw.



### CAUTION

Do not remove the screws other than blue ones. Removing other screws may cause a malfunction of the printer.

Plate securing screw

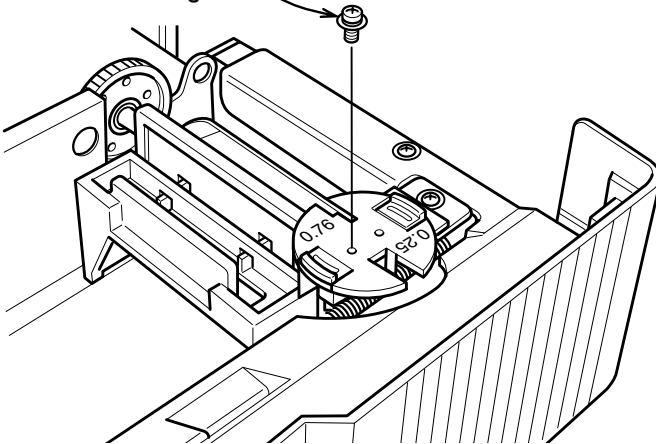

## 2. Remove the card thickness switching plate.

Pull the plate up while pressing the left and right knobs toward the center.

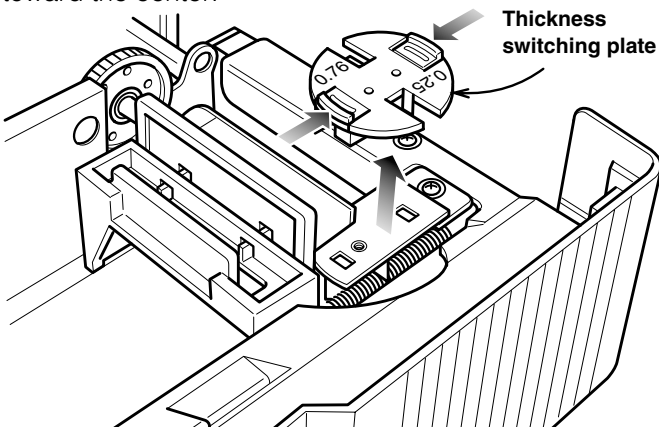

## 3. Remove the card thickness switching plate and invert the direction.

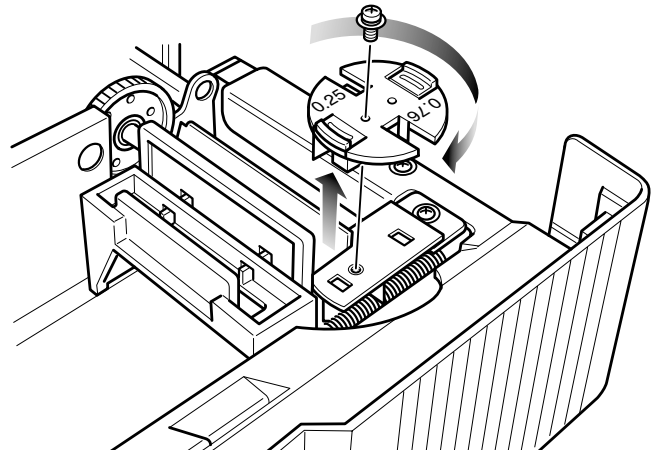

Move the plate back into position securely and tighten the screw.

## 4. Checking card feed

Set a few cards on the card tray.

Turn the roller drive gear in the arrow direction, and check that only one card is fed at a time.

Roller drive gear

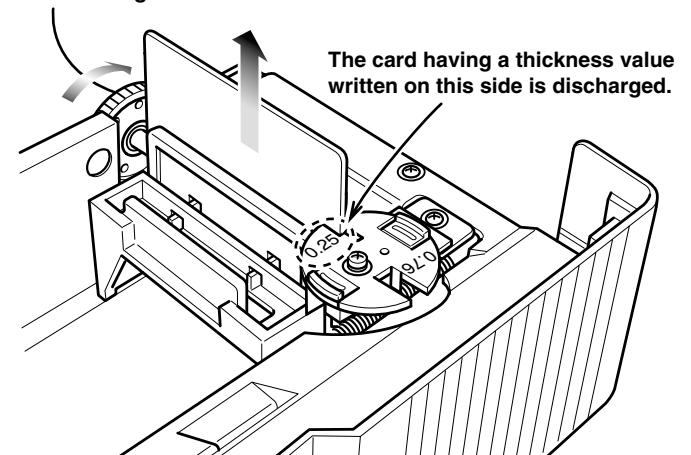

### Memo

If the card thickness is not switching properly, or cards cannot be fed because of the dirt on the feed roller,

**JAM (Hopper)**

appears on the LCD panel.

Check the proper setting of the card thickness plate, and clean the feed roller (see p.40).

# Before use

## Names of parts on the operation panel

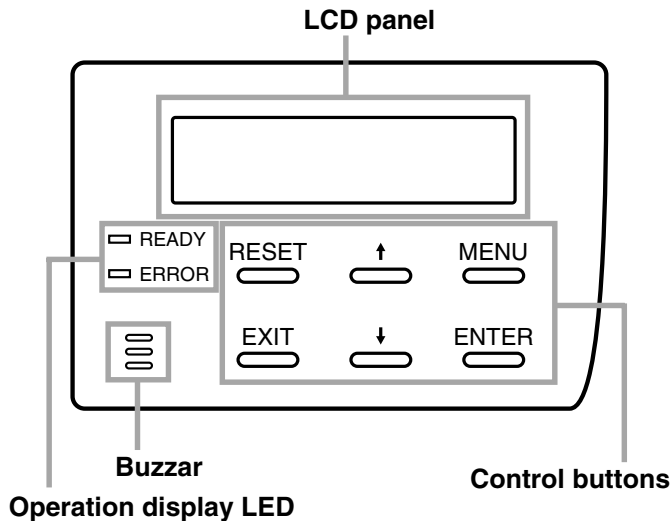

### Operation display LED

#### READY LED (green)

- ON : unit ready, printer in operation
- Flashing : receiving image data
- OFF : unit stopped due to error, or unit being set, initialized or preheated.

#### READY LED (red)

- ON : operation error
- OFF : normal status

**If an error occurs while the buzzer is set to ON, an alarm will sound. If this happens, the LCD background color will change to red.**

### LCD panel

#### During normal operation

- Upper line : operation status display  
(For details concerning the operation display, see p. 23 of this manual.)
- Lower line : counter display  
(Toggles between free counter/head counter and total counter.)

#### If an error occurs

- Displays the error status.  
(For details concerning the error display, see p. 41 ~ 43 of this manual.)

#### During user mode

- Displays various setting modes.  
(For details concerning settings, see p. 26 in this manual.)

#### Display background color

- Bright green : Initialization
- Orange : Card feeding
- Red : Error

The above background colors can be selected in user mode settings.  
(For details concerning settings, see p. 28 in this manual.)

### Setting buttons

**RESET**

Initializes the printer is reset by the software when an error occurs or an error is cancelled.

**MENU**

The user mode setting is displayed when the unit is in the Ready or Preheating status. The button is also used when canceling the operation lock during errors.

**ENTER**

Confirms the mode selected in the user mode setting.

The parameter setting for each mode can be adjusted during the user mode setting. Make sure to press the button to save the settings.

**EXIT**

Quits setting and returns to the upper level setting screen.

### Operation display LED contents and the LCD panel

Printer status	READY	ERROR	LCD panel
Mechanism set period	■	■	Initializing..
Preheat period	■	■	Preheating..
Ready period	☰	■	Ready
Printer operation period	☰	■	When an error occurs
Error occur	■	☰	*Depends on the error content
User mode	■	■ or ☰	Depends on the user mode content

☰ : LED on  
 ■ : LED off

For details, see p. 41 – 43 of this manual.

#### Initialization period

When the power is turned on, the printer performs positioning of the ink ribbon and retransfer film. It also initializes the mechanisms of the printer and check their operations. "Initializing" is displayed on the LCD panel during this period.

#### Preheating period

When the initialization of the mechanisms completes normally, the printer increases the temperatures of the retransfer roller and bend remedial roller up to the specified levels. "Preheating" is displayed on the LCD panel during this period.

### LCD operation display content

Boot Up..	<b>OS booting up</b> (this may not be displayed.)
Ver. xxx/xx/xx ←	* Firmware version <b>Shows firmware version number.</b>
Initializing..  xxxxx * * *	<b>Displayed during the initialization process.</b>
Preheating..  xxxxx * * *	<b>Displayed during preheating</b>
Ready  xxxxx * * *	* Displays Free/Head or Total, according to the counter select setting. <b>Ready status</b> * Print counter
Loading..  xxxxx * * *	<b>Displayed during feeding</b>
Printing..  xxxxx * * *	<b>Displayed during printing</b>
Encoding..  xxxxx * * *	<b>Displayed during encoding</b>
Retransfer..  xxxxx * * *	<b>Displayed during retransfer</b>
Unloading..  xxxxx * * *	<b>Displayed when cards are discharged from the NG card outlet</b>
Cleaning..	<b>Displayed during cleaning operations</b>
Sleeping..	<b>When the heater status is OFF because of the power save function</b>



# Operation

## Turning on the power

### 1. Before turning on the power, check the following:

- Make sure that the printer door is completely closed.
- Make sure that the card tray is completely closed.
- Make sure that the host computer is correctly connected.
- Make sure that any peripheral equipment is correctly connected.
- Make sure that the power supply outlet is correctly connected.

**Only switch the unit on after checking the above points.**

\* When operating this unit in the stand-alone mode, or if this unit is turned ON when a connected host computer has not yet been turned ON, the LCD panel indication may freeze with Ver. xxx/xx/xx (the xx is varying according to the firmware version.) This occurs because the SCSI bus is locked. If this occurs, turn OFF the power and return the bit 2 on the BUS switch to on the rear of the unit to the factory settings. Then turn ON the power again. For the factory settings, refer to p. 10 of this manual or the indication on the rear panel of the unit.

### 2. Turn the power ON.

(I represents ON and O represents OFF.)

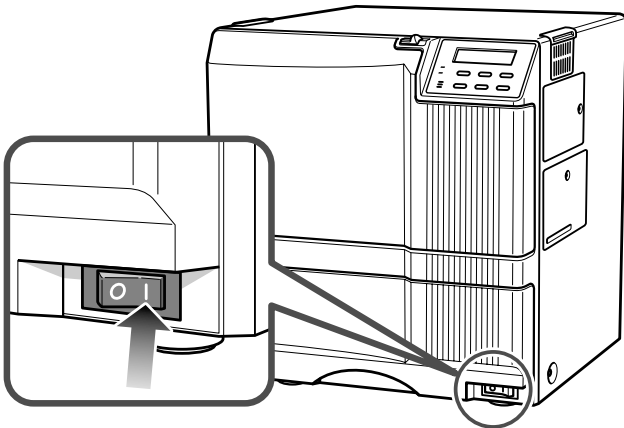

Before turning on the host computer, make sure that the LCD panel displays Preheat or Ready.

### 3. The unit will be in the ready status approximately 4 minutes after turning on the power.

The operation display LED (READY LED) will light up.

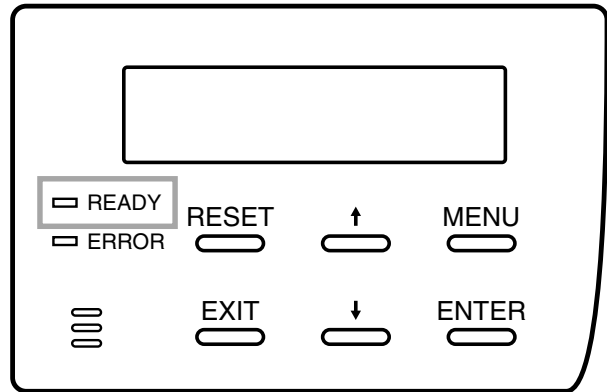

**CAUTION** Do not turn the power off while the LCD panel displays 'Boot up' to 'Initializing', as this may cause malfunctions.

### Making settings in the user modes

When the LCD panel displays Ready or Preheating,

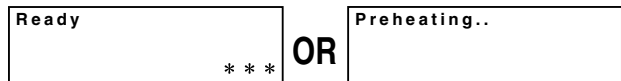

press  button.

For details concerning each user mode setting, see p. 26 of this manual.

### 4. Enter the control command from the host computer to print cards.

The operation display LED (READY LED) will flash while the unit is receiving image data from the host computer.

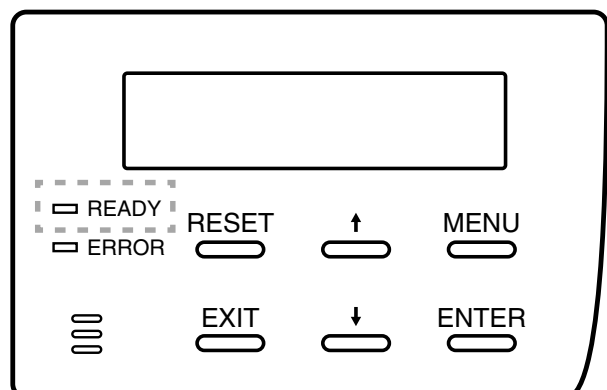

Be sure NOT to do any of the following during printing operations:

- Do not open the printer door.
- Do not open the card tray.  
(while the LCD panel displays 'Loading')
- Do not turn off the power supply.
- Do not unplug the unit.
- Do not pull out the connection cable.

Failure to observe the above points will cause printing to be aborted and may result in a malfunction of the unit.



### CAUTION

When the printer was occurred an error during printing operation caused by above-mentioned operation or others, the retransfer film was rewinded about 3 panels. If the printer is turned off and on the power or is initialized, the printer occur the printing an error which is "INK RUNOUT" or print results problem because of the printer try to print the used retransfer film. Wind up the retransfer film about 3 panels by unused panel. See p.18 "Caution when loading the retransfer film cassette and/or the ink ribbon cassette" and p.25 "On initialization when the retransfer film cassette and/or the ink ribbon cassette is loaded".

## Turning off the power



### 1. Check the printer status.

In ready, preheat or error status, check that printer operations are suspended.

### 2. Turn off the printer's power.



Always wait 10 seconds or more before turning the power back on again.

## About the RESET button

When an error occurs in the printer, press the  button, then the  button.

The printer is initialized with this operation.

If the error still persists, see p.41 and take the appropriate actions.

Then, press the  button, and the  button again. The printer is initialized, and returns to the "Ready" state.

(When you turn off the power, these procedures are not necessary.)

## On Initialization when the retransfer film cassette and/or the ink ribbon cassette is loaded

Dust or foreign particles may attach on the surface of retransfer film and ink ribbon when their cassette are removed from the printer.

This may cause defective printing such as image void, defective retransfer etc.

To Avoid this, it is recommended that the retransfer film and the ink ribbon are wound up one or two panels after they are reloaded.

Please follow the initialization procedure described below:

### 1. Turn the power switch on, and wait until the LCD indicate or displays "Preheat" or "Ready".

### 2. Depress the key. LCD indicator displays:

```
Initialize
                                     OK?
```

### 3. By depressing the key or the key, the LCD indicator change accordingly as shown below.

Select the wind-up condition, one or two panels. (This set up is not memorized.)

```
Initialize
                                     2'nd Panel, OK?
```

- Initialized after two panels of the retransfer film and the ink ribbon are wound up.

```
Initialize
                                     NEXT Panel, OK?
```

- Initialized after one panels of the retransfer film and the ink ribbon are wound up.

```
Initialize
                                     OK?
```

- Initialized without winding up. (Default)

### 4. By depressing the key, the printer is initialized according to the selected above set up condition.

# Operation (continued)

## User modes

The settings for printing media, card, etc. can be made in the User mode.







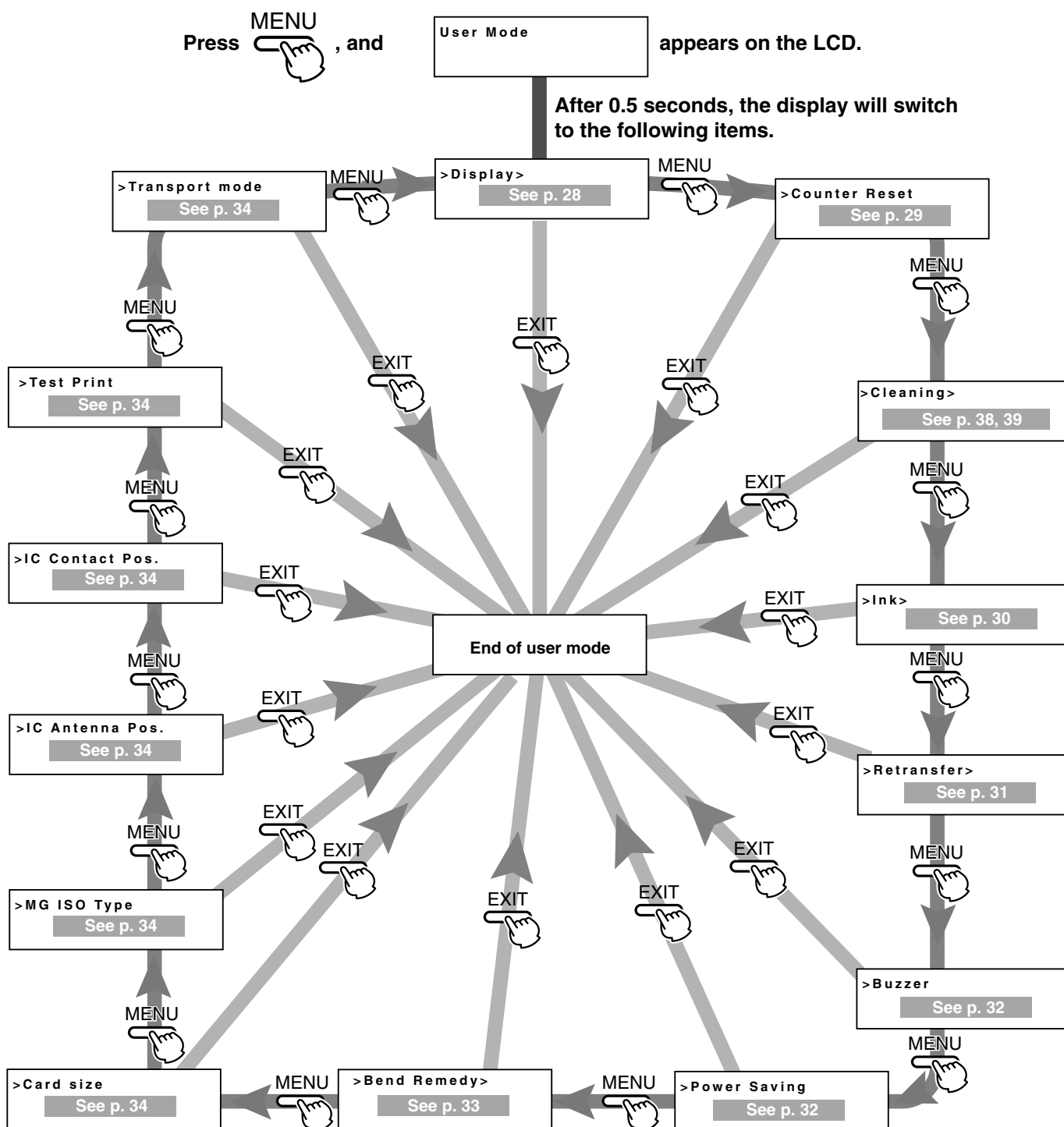









Press the MENU button when the unit is in the Ready, Preheat or Error status to suspend printing operations.

## User mode screen flow



## User mode settings

Main menu	Submenu	Factory setting
>Display> <b>Display mode</b>  See p. 28	>>Counter Total <b>3 counter type settings:</b> [Total, Head, Free]	Total
	>>Contrast -2 <b>LCD contrast setting:</b> 7 gradations from -3 to +3, the higher the value the stronger the contrast.	0
	>>Back Color BLUE <b>LCD background color setting:</b> 8 options	SKY BLUE
>Counter Reset OK?	<b>Counter reset mode</b> <b>For free counter resetting:</b> press the ENTER button.  See p. 29	—
>Cleaning> OK?	<b>Cleaning mode</b> <b>For cleaning mode setting:</b> Magnetic head and card feeder roller execution  See p. 29	—
>Ink> <b>Ink mode</b>  See p. 30	>>Ink Type YMCK:0 <b>Setting the ink ribbon:</b> set the ink type	YMCK : 0
	>>Black Level 0(Standard) <b>Setting the black value K:</b> 7 gradations can be set from -3 to +3, the larger the value the darker the printing.	0
	>>Black Mode Standard <b>Setting the K printing mode:</b> 2 options [standard and fine]	Standard
	>>SP-Ink 1 -3 >>SP-Ink 2 Level <b>Setting the special ink SP-Ink 1, SP-Ink2 darkness:</b> 7 gradations can be set from -3 to +3, the larger the value the darker the printing.	0
>Retransfer> <b>Retransfer mode</b>  See p. 31	>>Media Type Standard:0 <b>Setting the retransfer film:</b> setting the film type [1000, 250] - two types	Standard : 0
	>>Temp. Level 0(Standard) <b>Setting the retransfer roller temperature:</b> 8 gradations can be set from -5 to +2, the larger the value the higher the temperature.	0
	>>Speed (Front) -2 <b>Setting the retransfer speed:</b> 5 gradations can be set from -2 to +2, the larger the value the faster the speed.	+2
	>>Speed (Back) -2 <b>Setting the rear retransfer speed:</b> 5 gradations can be set from -2 to +2, the larger the value the faster the speed.	+2
>Buzzer On	<b>Buzzer mode</b> <b>Setting the buzzer ON/OFF:</b> 2 settings [on and off]  See p. 32	On
>Power Saving Off	<b>Power saving mode</b> <b>Setting the time for the power saving mode:</b> 9 options [off, 5, 10, 15, 20, 25, 30, 45 and 60] (units: minutes)  See p. 32	off
>Bend Remedy> <b>Bend Remedy mode</b>  See p. 33	>>Temp Level off <b>Bend remedy roller temperature setting:</b> 9 gradations can be set from -5 to +2, the larger the value the higher the temperature.	0
	>>Speed -2 <b>Bend remedy speed setting:</b> 5 gradations can be set from -2 to +2, the larger the value the faster the speed.	+2
	>>Cooling Time -2 <b>Cooling time setting:</b> 16 gradations can be set: none and 1-15 (units seconds).	None
>Card Size Standard	<b>Card setting mode:</b> <b>Card Size setting:</b> 2 options [Standard and Cybernetic]  See p. 34	Standard
>MG ISO Type Lo-Co	<b>Antimagnetic setting mode:</b> <b>ISO card antimagnetic setting:</b> 2 options [Lo-Co and Ho-Co]  See p. 34	Hi-Co
>IC Antenna Pos. None	<b>Non-contact IC antenna setting mode:</b> <b>Non-contact IC antenna position setting:</b> 4 options [None, Built-in, Ext. Unit, Added on]  See p. 34	—
>IC Contact Pos. None	<b>IC contact position setting mode:</b> <b>IC contact position setting:</b> 3 options [None, Built-in, Ext. Unit]  See p. 34	—
>Test Print OK?	<b>Test print mode:</b> <b>to carry out test printing:</b> press the ENTER button.  See p. 34	—
Transport mode OK?	<b>Transfer Mode:</b> <b>Transfer mode setting:</b> press the ENTER button.  See p. 34	—

# Operation (continued)

## Display mode settings

The unit has the following three settings for the display mode. Allows selection of which counter value is displayed when the power is turned on.



### CAUTION

● The beep sounds when pressing the Enter button to save the settings in the user setting mode.

● The beep will not sound if the buzzer mode setting (see p.32) is set to off.

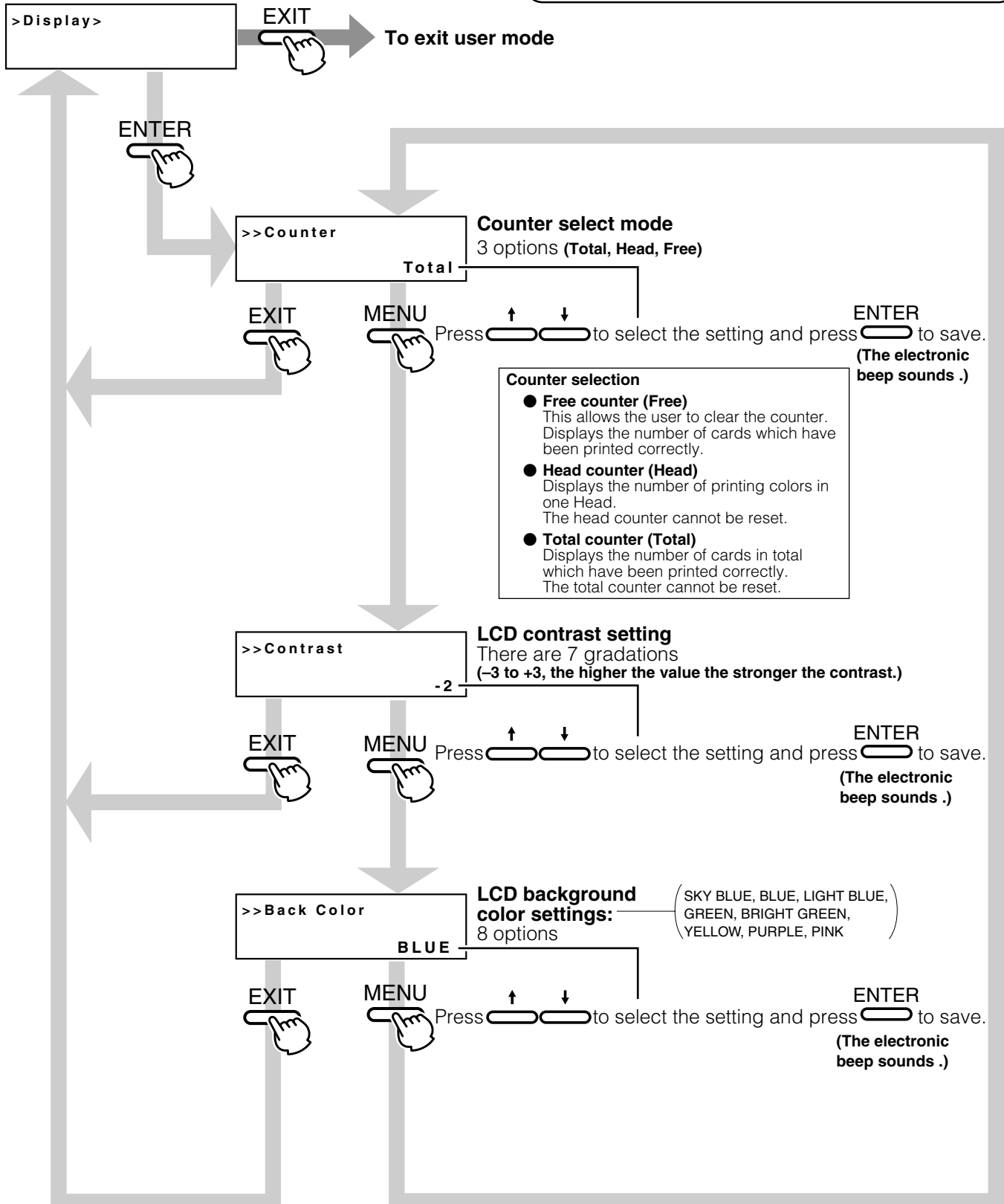

## Clearing the free counter

Reset the free counter.  
The [Total] counter and [Head] counter cannot be reset.

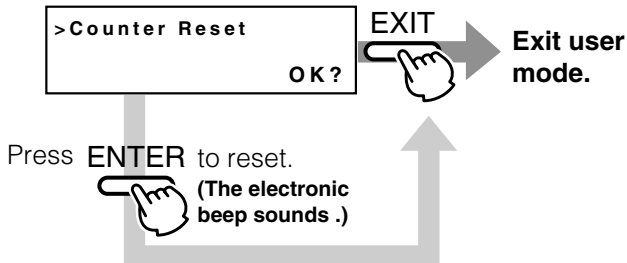

To check that the counter is reset to zero, select "Free Counter" in "Setting the counter type" on p.28.

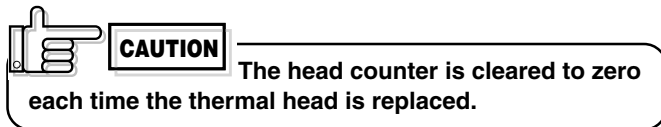

## Cleaning mode

The printer is provided with an operation mode for cleaning the magnetic head and card feed roller to keep the printer in the best condition.  
See p.38 and p.39 for executing the cleaning mode.

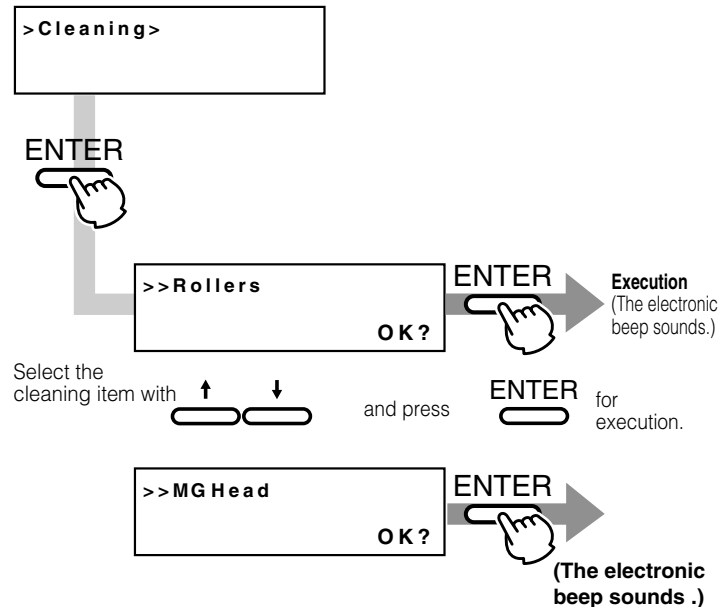

To exit the cleaning mode, turn off the power after cleaning.

# Operation (continued)

## Ink mode setting

Change settings according to the ink ribbon used.

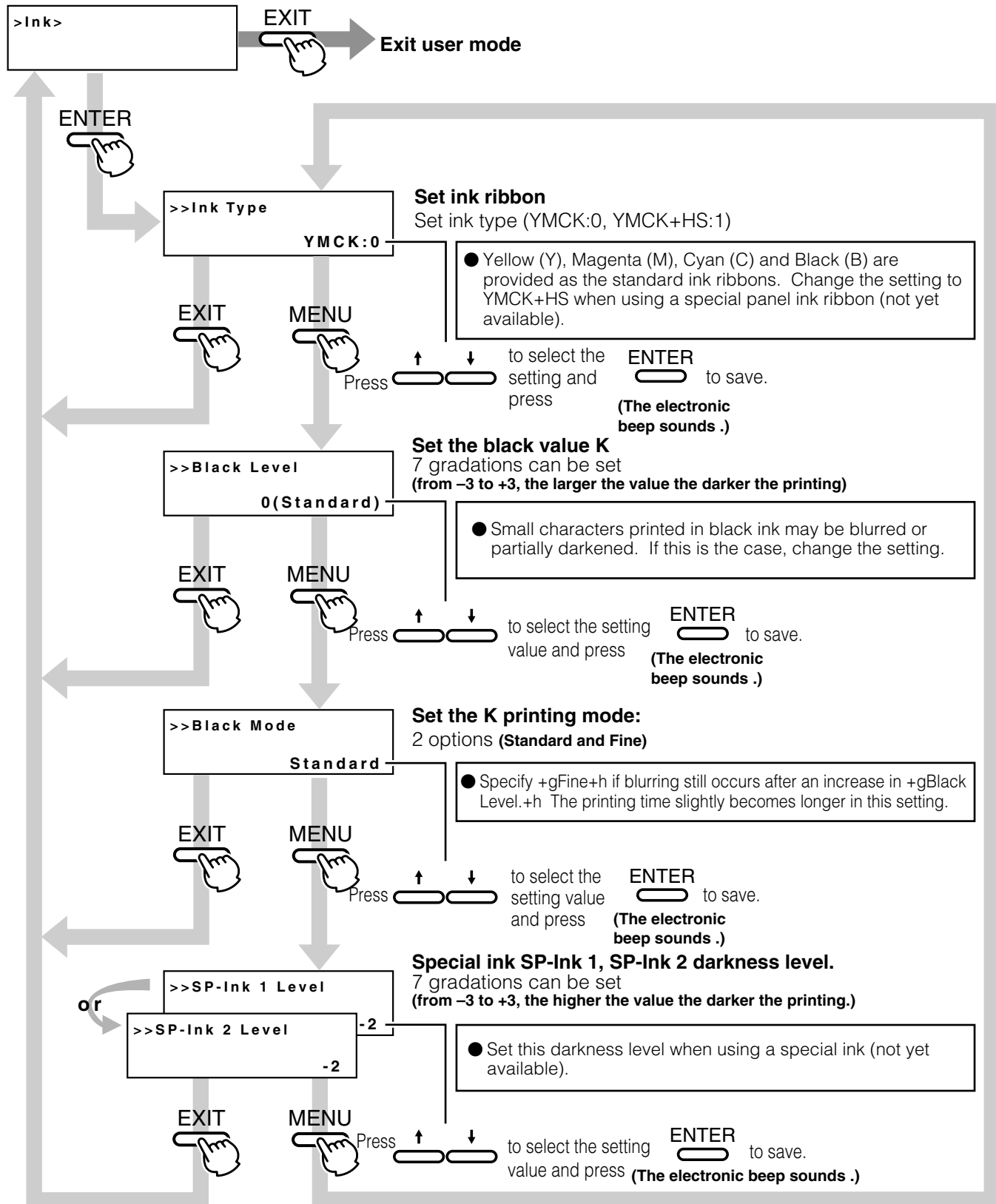

## Retransfer mode setting

Change settings according to the retransfer film and card used.

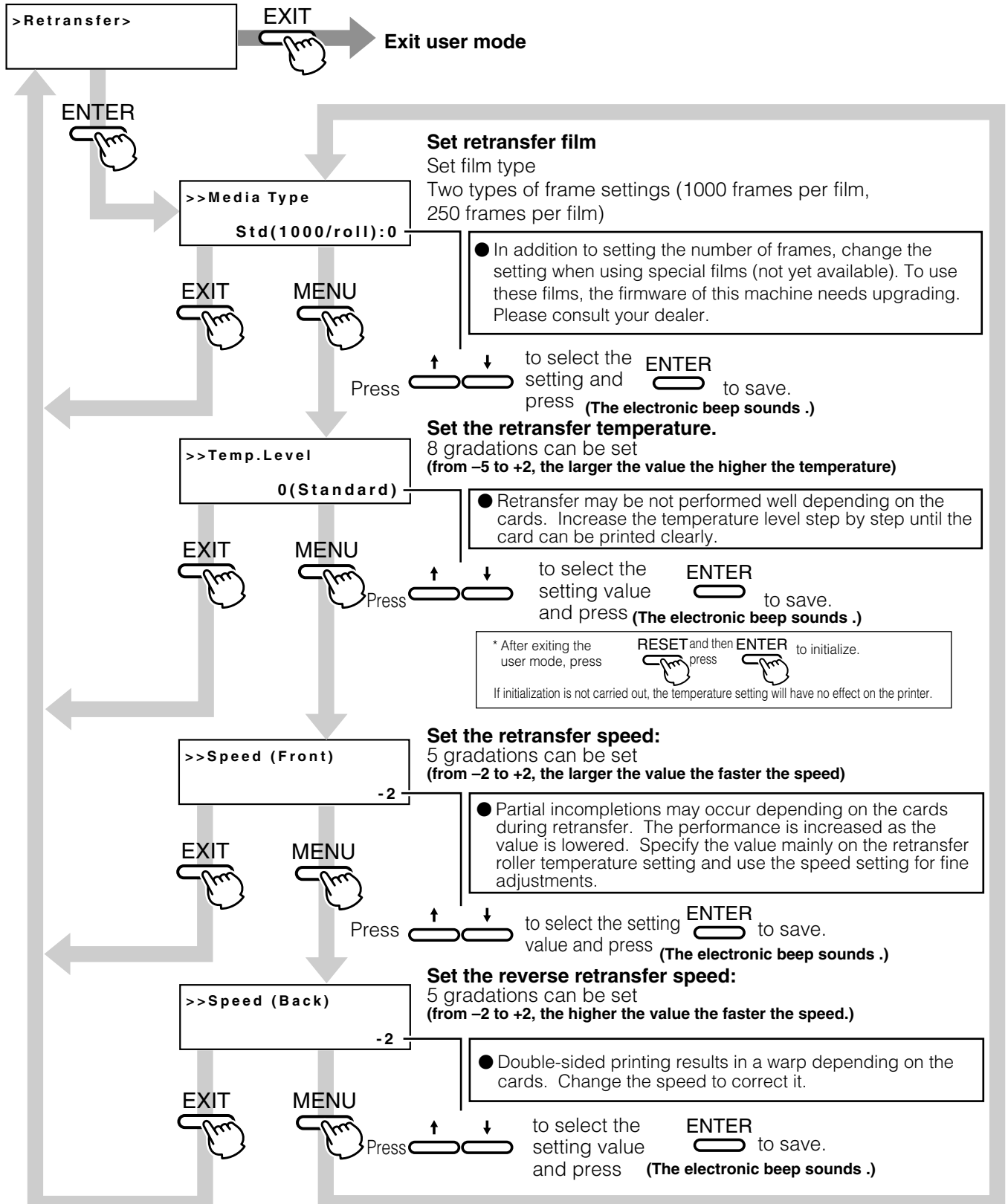



# Operation (continued)

## Buzzer mode setting

The buzzer indicating errors can be turned on or off.

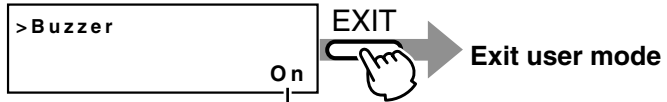

**Set the buzzer:**  
there are two settings  
(On, off)

Press to select the setting and press to save.  
(The electronic beep sounds.)

When Off is specified,  
● electronic beep sound indicating an error,  
● electronic beep sound indicating the number of cards,  
and  
● electronic beep sound indicating settings saved with  
the ENTER button in the user mode  
are muted.

## Power saving mode settings

The printer enters into the power save mode after a specified period of time if none of operation buttons are touched in the Ready state. The heat roller for retransfer, bend remedial roller, and LCD back-panel are turned off in the power save mode.

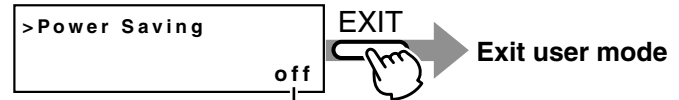

**Power saving settings:**  
there are 9 options.

Press to select the setting and press to save.  
(The electronic beep sounds.)

Press the EXIT button to cancel the user mode, and the printer starts.

**Off:**  
Not in power saving mode.  
**Setting options: [5,10,20,25,30,45,60] (units: minutes)**  
**[5,10,15,20,25,30,45,60] (units: minutes)**  
If printing is not to be carried out for a period longer than the set time, switch the unit's heater off. (Power save status)

"Sleeping" appears on the LCD panel in the power save mode. The operation buttons are disabled in this mode. See step 2 in "Canceling the power save mode" to enable the operation buttons.

**Sleeping**

The printer moves to the power save mode when the specified time arrives even if you turn off the printer and turn it on again.

### Canceling the power save mode

#### 1. From the host computer

Enter a control command to print the card. The power save mode is cancelled, and printing automatically starts upon completion of preheating.

#### 2. Temporary cancellation

To cancel the power save mode temporarily on the printer, press , then to initialize the printer.

#### 3. Permanent cancellation

Cancel the power save mode temporarily as described in step 2, and change the power save mode setting to OFF.

## Setting the bend remedy mode

Single-sided printing may cause a bend depending on the cards. Adjust the setting to get rid of the bend.

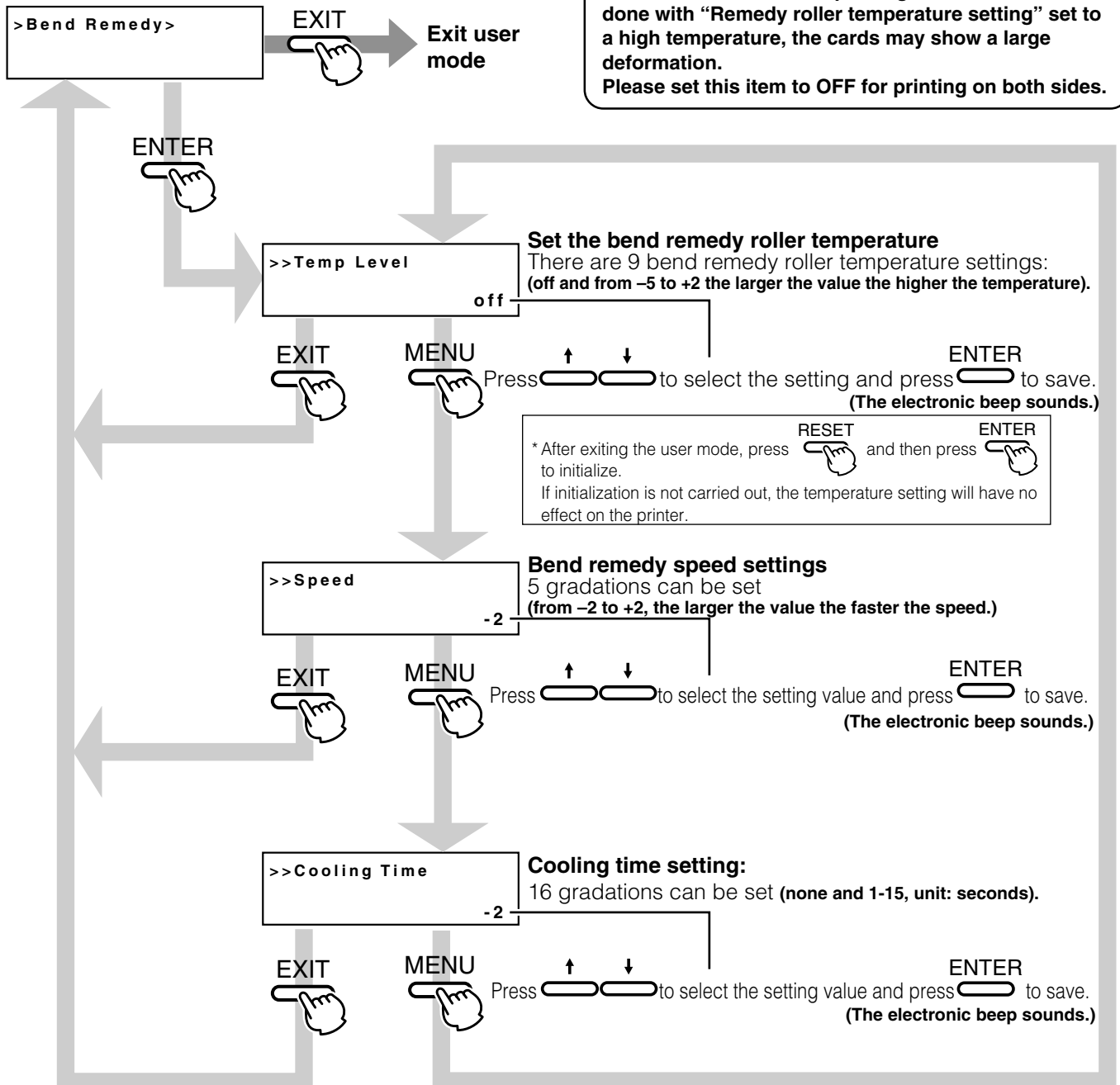

**CAUTION** If the bend remedy temperature setting is set to off from any other setting, the preheating status will remain the same until the roller temperature falls (for approximately 10 minutes). This is not a malfunction. Leave the unit in ready status and wait.

- Memo**
- Setting temperature and speed of the bend remedial roller**  
Adjust the “roller temperature” setting in principle to correct the bend of the card, and use the “correction speed” setting for fine adjustments.
  - Setting waiting time for cooling the card**  
This provides the time for a special film, which will be marketed in the future, to cool down to prevent the card and retransfer film from sticking together after printing.

# Operation (continued)

## Card size setting mode

The printer is designed to load two sizes of cards. Set the card size according to the card to be printed.

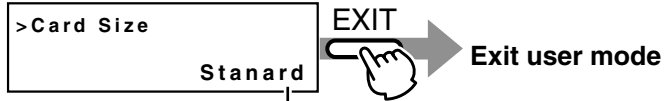

**Set the card size:**  
2 settings [Standard and Cybernetic]

Press to select the setting and press to save. (The electronic beep sounds.)

**Standard:**  
54.0mm x 85.6mm (complies with ISO7810)  
**Cybernetic:**  
57.5mm x 85.0mm

## IC contact setting mode

When using IC cards, specify the contact position to stop the cards.

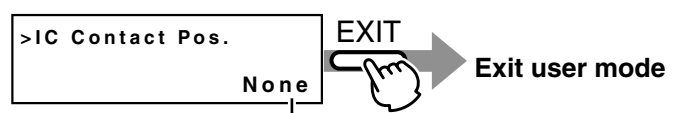

**Set IC contact position:**  
3 settings

Press to select the setting and press to save. (The electronic beep sounds.)

**None**  
No contact  
**Built-in**  
A built-in contact is being used  
**Ext. Unit**  
An IC unit contact is being used

## Antimagnetic setting mode

Set antimagnetic force for writing data on the ISO compatible magnetic stripe card.

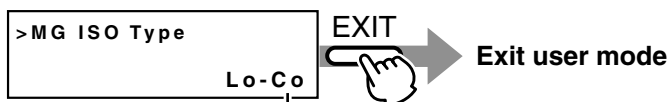

Press to select the setting and press to save. (The electronic beep sounds.)

**Lo-Co**  
238x10<sup>2</sup> [A/m] (300 [Oe])  
**Hi-Co**  
218x10<sup>3</sup> [A/m] (2750 Oe)

## Test print

Test print is provided for printing a test pattern contained in the printer (there is only one pattern). Operating the printer independent of the host computer enables you to find out the source of trouble if there is a problem in the system.

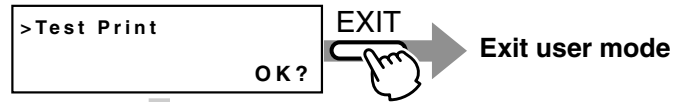

Press to carry out test printing. (The electronic beep sounds.)

Printing..

A single-sided color pattern is printed. When test printing is completed, the unit will automatically return to ready status.

## Non-contact IC antenna setting mode

To use non-contact IC cards, set the antenna position at which the cards stop.



**Non-contact IC antenna position:**  
4 settings

Press to select the setting and press to save. (The electronic beep sounds.)

**None**  
No antenna  
**Built-in**  
A built-in antenna is being used  
**Ext. Unit**  
An IC unit antenna is being used  
**Added on**  
A compact IC unit is being used.

## Transport mode

To set the transport mode.

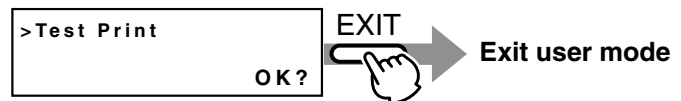

Press to carry out transport mode. (The electronic beep sounds.)

Please,  
Power off

Please turn off the power. Turning on the power, then the transport mode is canceled.



**CAUTION**

When shipping or moving the printer, you must set the transport mode. If the printer is not set the transport mode, it may have a damage.

# Care and cleaning

Always make sure that the unit is turned off before cleaning.

(However, cleaning of the discharge rollers and magnetic head should be carried out with the power turned on.)

To achieve the best performance from the printer, always check each part before use for dust and dirt and clean if necessary.

The following explains the main rollers that require cleaning. For details about other rollers, see p.40 (Internal roller layout).

Dust and dirt, particularly on the thermal head, rollers and cleaning rollers can cause print blurs and shifting of colors.

## Cleaning the cleaning rollers

The cleaning rollers remove dust and dirt sticking to the card. Cleaning the cleaning rollers after every use is recommended if the unit is used almost everyday.

Depending on the cards, there may be much dust and dirt. In such a case, perform cleaning every 100 to 200 cards. Do not do this, however, during printing operations.

### 1. Open the card tray.

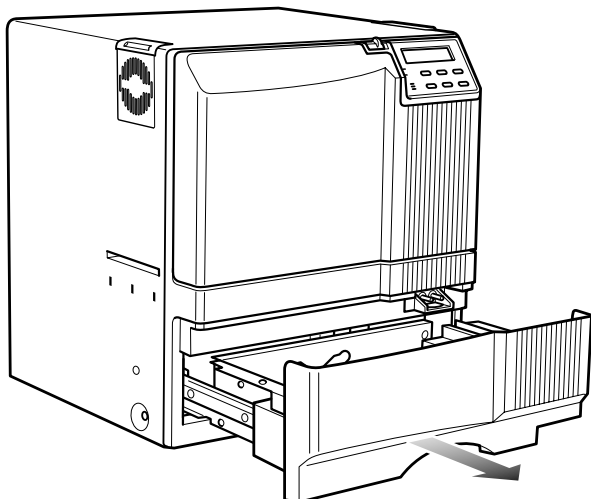

### 2. Remove the cleaning unit.

Pull out the cleaning unit toward you as shown in the illustration below.

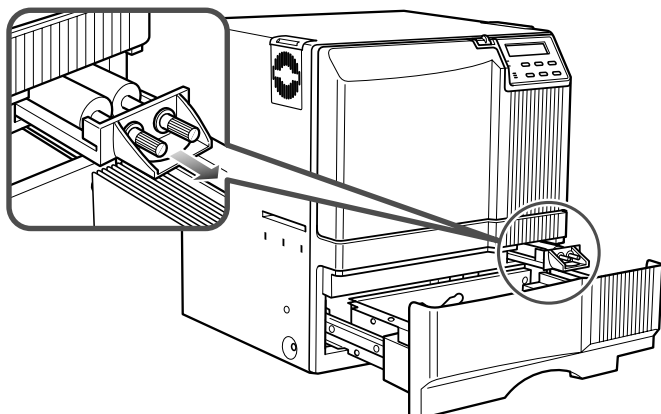

### 3. Wash the rollers of the cleaning unit with water.

Wash out dirt on the roller surface with your fingers. Do not use alcohol or detergents. The cleaning unit should be cleaned only with running water.

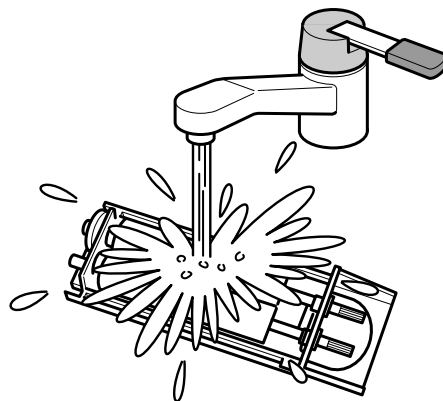

**CAUTION** After washing the cleaning unit with water, wait until it completely dries up and set it in the printer.

### 4. Push the cleaning unit back into the printer.

Push the cleaning unit with the rollers facing upward until it is securely back into the place.

### 5. Close the card tray.

**CAUTION** Deteriorated cleaning rollers may cause defects in the printed card. If the rollers begin to deteriorate, replace the cleaning unit. (We recommend replacement after a year)

# Cleaning (continued)

## Cleaning the thermal head

When the thermal head gets dirty, defects such as unwanted lines appearing on the printed card may occur. It is recommended to clean the thermal head after printing about 10,000 frames. The thermal head is a consumable component, that is, it has a limited service life.

1. Open the printer door and remove the ink ribbon cassette and the retransfer film cassette.

See p.14, 16 in this manual.

2. Wipe the cleaning head with a cotton bud (sold separately), dipped in alcohol (sold separately).

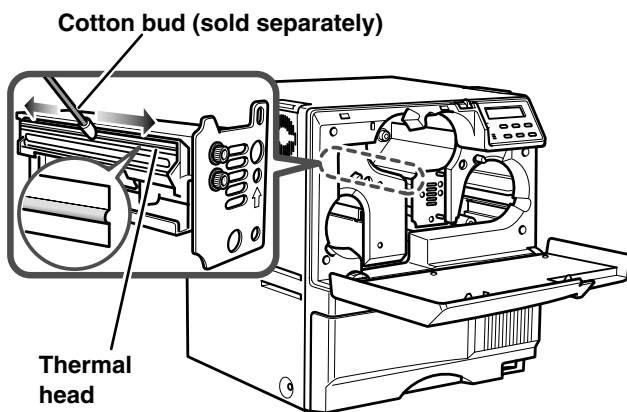

Wipe the head indicated with  horizontally.

3. Insert the ink ribbon cartridge and the retransfer film cassette, then close the printer door.



### CAUTION

- The thermal head may break if touched with an electrostatic charge. Discharge yourself by touching the printer frame (metallic part) with your hands before cleaning the thermal head.
- Use a cotton bud soaked with absolute ethanol. Be careful not to scratch the thermal head with hard materials like metal during cleaning.

## Cleaning the fan filter

When the fan filter gets dirty, partial omissions may occur on the printed cards, or the printing result looks dirty. It is recommended to clean the fan filter after printing about 10,000 cards.

1. Remove the fan filters located in two positions on the sides of the printer.

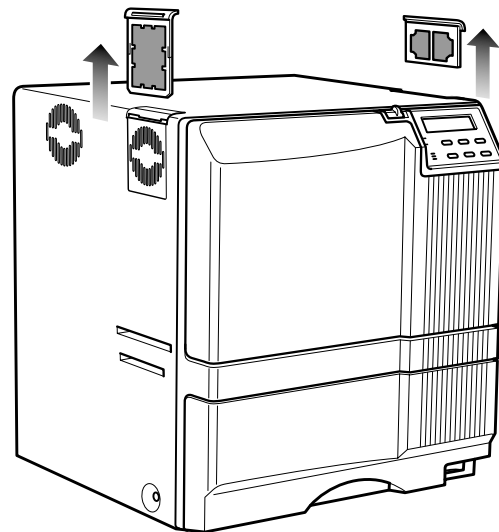

2. Remove the card tray.

See p.44 in this manual.

3. Remove the fan filter located on the base of the printer (inside the unit).

Bring down the fan filter while pressing its side (side ①). The fan filter can be taken out. Mount the fan filter by pressing this side.

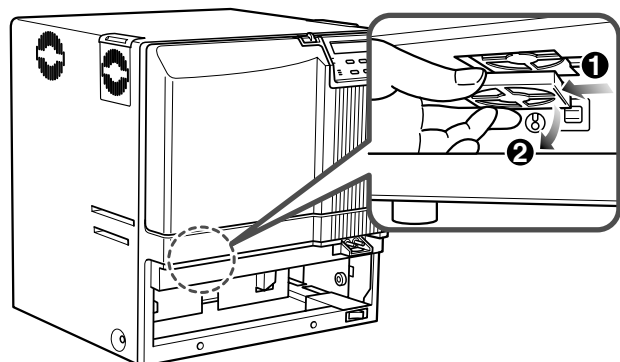

**4. Remove dirt on the fan filter using a vacuum cleaner or other cleaning equipment.**

Hold the sponge with your hand so that it is not sucked into the cleaner.

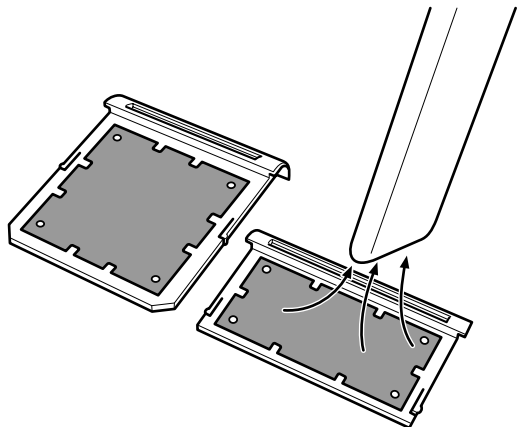

**5. How to attach the sponge**

**Side filter**

Press down the sponge into the dents at four corners, and set it under the tabs on the frame.

**Bottom filter**

Place the sponge under the tabs on the frame.

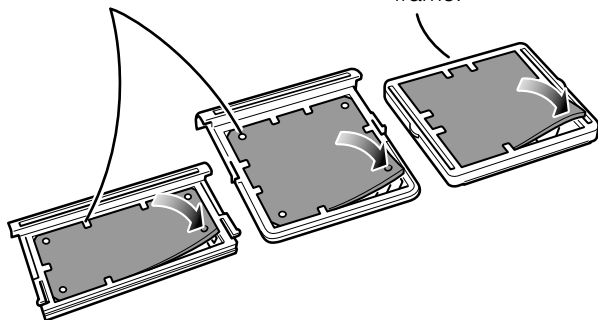

Replace the fan filter when it begins to deteriorate. Contact your dealer for details of replacing the filter.

**Cleaning the fan filter on the back side**

When the fan filter on the back side gets dirty, partial omissions on the printed cards may occur, or the printing result looks dirty. If you find the dust on the fan filter, you should clean the fan filter as follows.

**1. Remove the dust on this side vents using a vacuum cleaner or other cleaning equipment.**

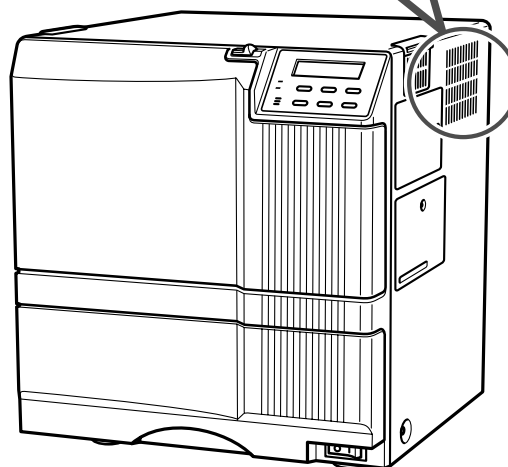
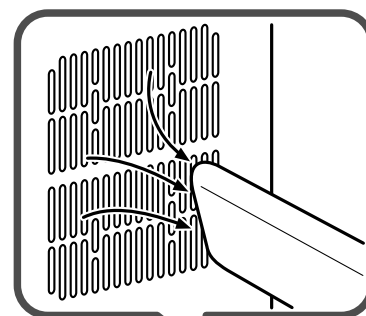

## Cleaning the card feed rollers

Dirty rollers are the major cause of jamming of the cards. It is recommended to clean the rollers once after printing about 1,000 cards. It is also recommended to carry out cleaning before the work, because the retransfer roller (heat roller) does not operate while it is hot.

1. Remove the retransfer film cassette.  
See p.16 in this manual.

2. Turn on the power of the printer.  
The printer initializes, and the [No Cassette] error is indicated.

3. From user mode select cleaning mode.

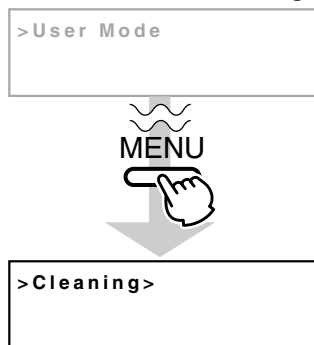

4. Press the ENTER button. Select [Rollers] with ↑ and ↓ buttons, and press the ENTER button.  
See p.26 in this manual.

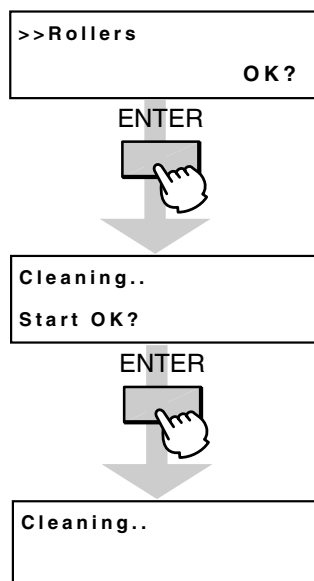

Insert the cleaning card in about 10 seconds. If you fails to set the card within this time, the printer returns to "Start OK?" Press the ENTER button again to proceed.

5. Set a cleaning card.

Peel off the protective paper from both sides of the cleaning card and insert it into the card discharge slot. The card will be drawn into the unit by the rollers and cleaning will then be carried out. Insert the card with its adhesive face upside down to repeat the cleaning procedure once more.

Cleaning card (accessory)

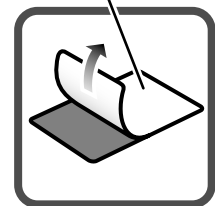
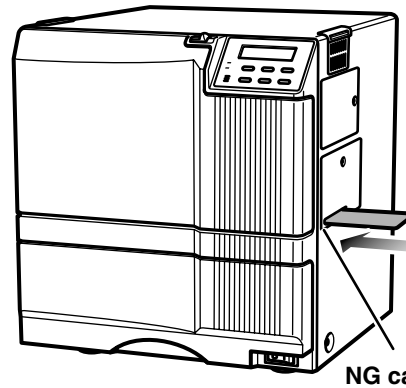

The cleaning card can be inserted only from the right side.



### CAUTION

• If the retransfer roller (heat roller) gets too hot,

HR is too hot!

appears on the LCD panel, and the printer returns to the Ready state.

Turn off the power of the printer, and wait until the roller completely cools down before starting the work. Confirm that the retransfer film cassette has been removed.

- The cleaning card does not go into the card discharge slot at the left side.
- If a card jam occurs, turn off the power, then turn on the power again. The jammed card will be discarded.

6. Turn off the power after the cleaning card is discharged.

Wait for 10 seconds before turning on the power again.



### CAUTION

The cleaning card can be used only once. If you use the dirty cleaning card many times, the dirt on the card moves onto the rollers, causing damages to the rollers. Consult your dealer for the cleaning card.

## Cleaning the card feed rollers and heat rollers

Dirty magnetic head will cause a write/read error. It is recommended to clean the magnetic head after printing about 1,000 cards. Cleaning the magnetic head is not necessary if the magnetic stripe card is not used.

1. Keep the ink ribbon and retransfer film cassettes in their mounting positions.

See p.14 to p.18 of this manual.

2. Turn on the power of the printer.

Go to the next step when the printer is in the Preheat or Ready state.

3. Specify the "cleaning" mode in the user mode.

See p.26 in this manual.

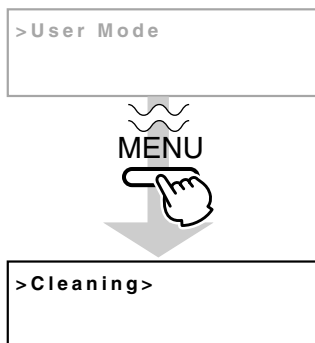

4. Apply alcohol on the magnetic head cleaning card.

Drip three or four drops of alcohol on the magnetic stripes.

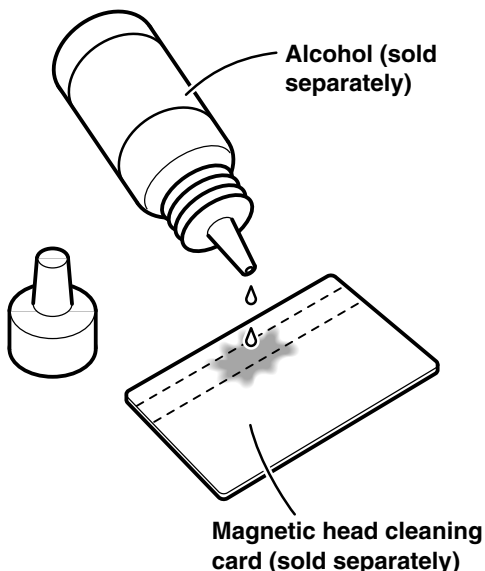

5. Set the card on the card tray.

Place the card in right direction. See p.20.

6. Press the ENTER button, select "MG Head" with the ↑ or ↓ button, and press the ENTER button.

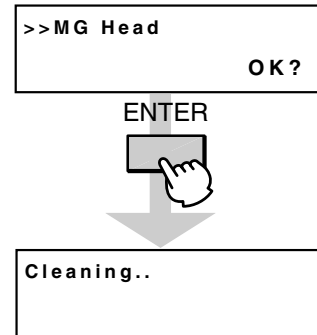

7. When the cleaning card is discharged, turn off the power of the printer.

Wait for 10 seconds before turning on the power again.

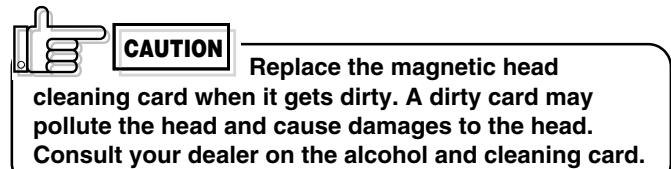

## Once printer servicing and cleaning have been completed

Once servicing and cleaning of the printer have been completed, check to make sure that all parts have been replaced properly. Improper replacement of parts may result in the power not turning on or in operating errors.



# Troubleshooting

## Layout of rollers inside the printer

Below is a diagram of the layout of rollers inside the printer. Refer to this diagram in the event of card jams and when cleaning the rollers.

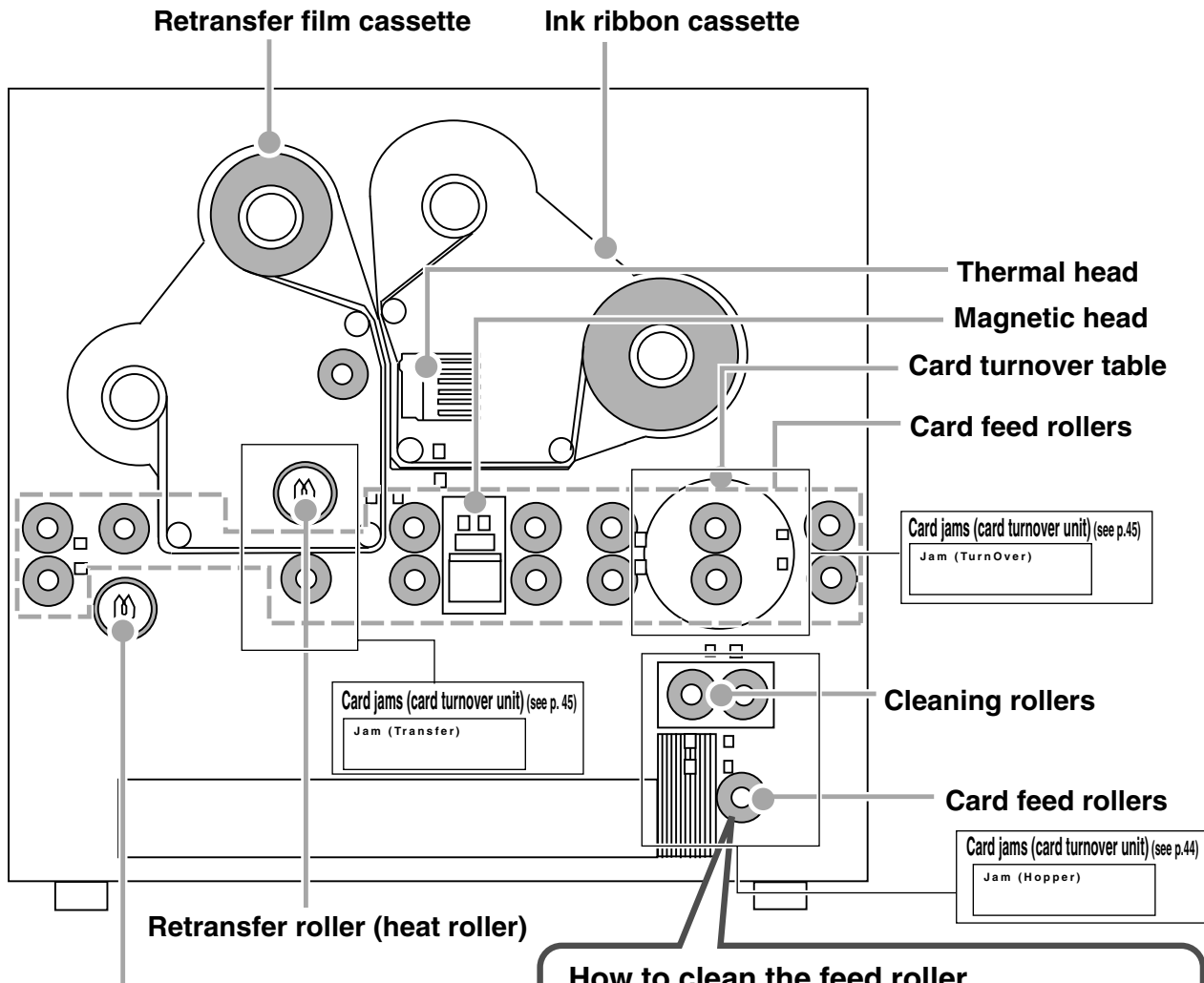

### How to clean the feed roller

1. Open the card tray, and take out the cards from the tray.
2. Move the card bracket until it locks.
3. Clean the feed roller with felt (sold separately) soaked with absolute ethanol.

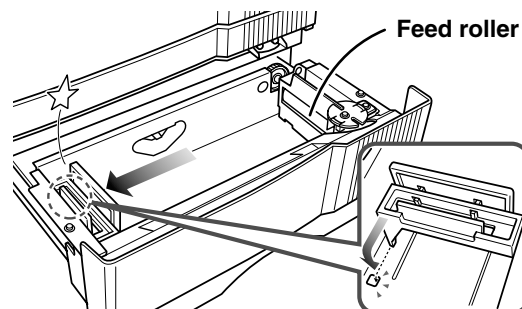







All rollers require routine cleaning.

- The card feed rollers, bend remedial roller and retransfer roller can be cleaned on cleaning mode. (See p.38 in this manual.)
- The cleaning roller can be cleaned by water washing. (See p.35 in this manual.)

## Error code listing

The meaning of “reset → enter buttons” in the list is, after pressing the Reset button, press the Enter button to initialize the unit.

Error code	Description of error	Remedy
Please, Power Off.	The power must be turned off so that the unit can be initialized.	Turn the power off and then on again.
Please Remove Media Cassette	The cleaning mode can not be set because there is a retransfer film in the unit.	Remove the retransfer film cassette, then press the “reset → enter buttons” and set the cleaning mode again.
HR is too hot.	The cleaning mode can not be set because the temperature of the heat roller is too high.	1. Turn off the power and allow about 20 minutes for the heat roller to cool. Then turn the unit on and set the cleaning mode again. 2. Confirm that the retransfer film cassette has been removed.
Jam (Hopper)	Card jam (hopper section)  See p.44	Remove cards from the hopper. Press the “reset → enter buttons” and initialize the unit.
Jam (TurnOver)	Card jam (turnover)  See p.45	Remove cards from the turnover section. Press the “reset → enter buttons” and initialize the unit.
Jam (MG)	Card jam (encode section)	Press the “reset → enter buttons” and initialize the unit. If no cards are discharged, remove the cards, press the “reset → enter buttons” and initialize the unit.
Jam (Transfer)	Card jam (retransfer section)  See p.45	Remove the cards from the retransfer section. Press the “reset → enter buttons” and initialize the unit.
Jam (Discharge)	Card jam (paper discharge section)	Remove the cards from the paper discharge section. Press the “reset → enter buttons” and initialize the unit.
Media Broken	The retransfer film has broken  See p.43	Rejoin the retransfer film. Press the “reset → enter buttons” and initialize the unit.
Media Search	Retransfer film search error	Reset the retransfer film. Press the “reset → enter buttons”. Call for service if the problem persists.
Media Run Out	The retransfer film has run out	Replace the retransfer film. Press the “reset → enter buttons” and initialize the unit.
Ink Broken	The ink ribbon has broken  See p.43	Rejoin the ink ribbon. Press the “reset → enter buttons” and initialize the unit.
Ink Search	Ink ribbon search error	Reset the ink ribbon. Press the “reset → enter buttons” and call for service if the problem persists.
Ink Run Out	The ink ribbon has run out	Replace the ink ribbon. Press the “reset → enter buttons” and initialize the unit.
Turn Over Unit	Turnover mechanism error  See p.45	Press the “reset → enter buttons” and call for service if the problem persists.
Heater Cam	Heat roller operation error	Press the “reset → enter buttons” and call for service if the problem persists.
No Card	1. No card 2. The hopper tray is open or has been removed.	1. Replenish the cards. 2. Close the tray correctly.
Door Open	The printer door is open	Close the door. Press the “reset → enter buttons” and initialize the unit.
No Cleaning Ro.	Cleaning rollers missing	Attach the cleaning rollers. Press the “reset → enter buttons” and initialize the unit.
No Cassette	Cassette missing	Attach both the ink ribbon cassette and the retransfer film cassette. Press the “reset → enter buttons” and initialize the unit.

# Troubleshooting (continued)

Should your printer require servicing, turn it off and unplug it and make inquiries at the outlet where it was purchased.

Error code	Description of error	Remedy
Hardware ..	Hardware error	Turn the power off and then on again. Call for service if the problem persists.
MG Encode ..	MG encode error	Check the direction of the magnetic cards. Press the "reset → enter buttons" and call for service if the problem persists.
TR Overheat	Retransfer roller overheating	Turn the power off and then on again. Call for service if the problem persists.
TR Broken	Retransfer roller malfunction	Turn the power off and then on again. Call for service if the problem persists.
TR Sensor Broken	Retransfer roller thermister malfunction	Turn the power off and then on again. Call for service if the problem persists.
RR Overheat	Bend remedy roller overheating error	Turn the power off and then on again. Call for service if the problem persists.
RR Broken	Bend remedy roller malfunction	Turn the power off and then on again. Call for service if the problem persists.
RR Sensor Broken	Bend remedy roller thermister malfunction	Turn the power off and then on again. Call for service if the problem persists.
Overcool	Overcool	The usage environment temperature is too low. Use at the specified usage environment temperature. (Call for service if the problem persists.)
Head Overheat	Thermal head overheated	Turn the power off and leave the unit for about 10 minutes before switching on again. (Call for service if the problem persists.)
EEPROM Broken	EEPROM malfunction	Turn the power off and then on again. Call for service if the problem persists.
MG Unconnected	MG connection error	Turn the power off and then on again. Call for service if the problem persists.
MG Mechanical	MG mechanical error	Turn the power off and then on again. Call for service if the problem persists.
MG Hardware ..	MG hardware error	Turn the power off and then on again. Call for service if the problem persists.
MG Write	MG writing error	Check the type and direction of the magnetic cards and press the "reset → enter buttons". Call for service if the problem persists.
MG Read	MG reading error	Check the type and direction of the magnetic cards and press the "reset → enter buttons". Call for service if the problem persists.
MG Communicate	MG communication error	Turn the power off and then on again. Call for service if the problem persists.
EXT. Unconnected	Connected external device malfunctioning	Check that the cable linking the external unit and the printer is properly connected and press the "reset → enter buttons". Call for service if the problem persists.

Error code	Description of error	Remedy
EXT. SW Setting	External device switch setting error	Turn the power off and then on again. Call for service if the problem persists.
EXT. Jam	External retransfer unit jam error	Press the "reset → enter buttons" and remove cards if they are not discharged. Press the "reset → enter buttons" and call for service if the problem persists.
EXT. Communicate	External unit communications error	Turn the power off and then on again. Call for service if the problem persists.

## Mending broken ink ribbon and retransfer film

If the ink ribbon or retransfer film is broken, mend it in the following procedures:

- 1. Trim neatly the end of broken portions with a pair of scissors.**
- 2. Align both ends and apply the Scotch tape in the center of the aligned ends.**  
Please do not discard the used ink or film on the winding side.
- 3. Turn the ribbon or film to the winding side with your hand until the mended portion is completely wound up.**

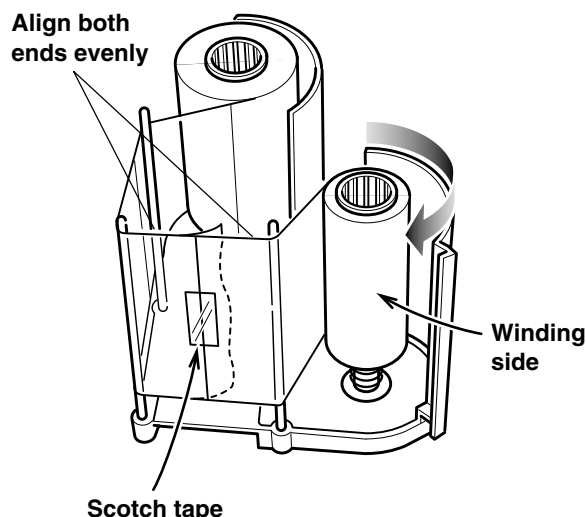

 **CAUTION** Set the ink ribbon and retransfer film with care. See p.14 and p.16.

## About printing errors

If blurring or color shifts occur in your print results, clean all rollers starting with the cleaning rollers. Some image errors may depend on the design of the card to print. In particular, wrinkles can easily occur if large surfaces are printed with high density ink. To avoid such problems, contact the dealer where the printer was purchased concerning card designs.

# Troubleshooting (continued)

## Removing card jams

To determine the part of the machine affected by a card jam refer to the error code on the operation panel LCD on the printer and the relevant page in this manual.

When removing a jammed card, make sure that the power switch is set off before carrying out the following procedure.

### Hopper jam

#### 1. Pull out the card tray.

To remove the card tray, pull it out toward you until it no longer moves and lift it.

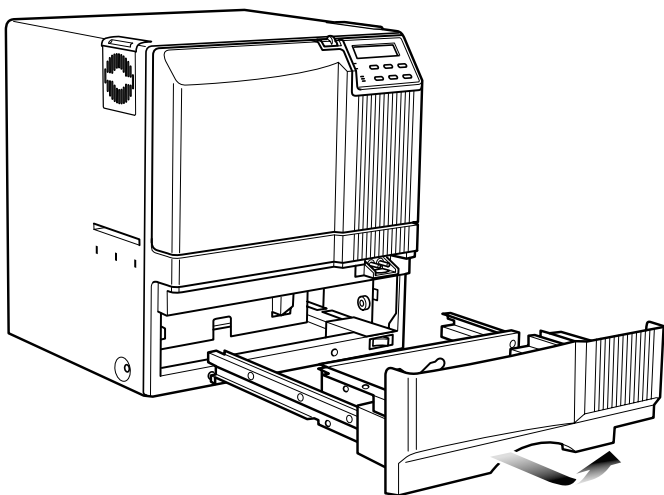

#### 2. Remove the jammed cards.

If you can hold the jammed card, pull it out.

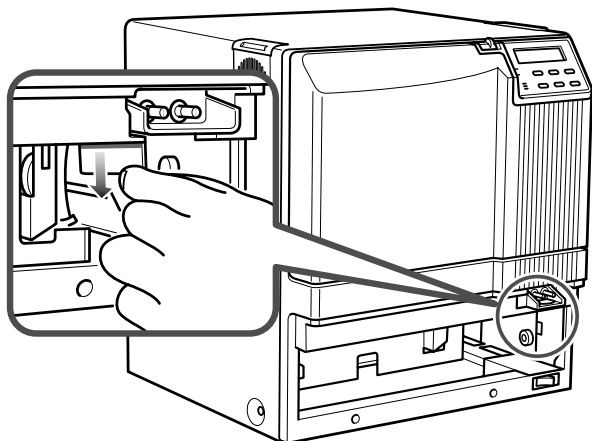

#### If you cannot hold the jammed card:

Pull out a small portion of the cleaning unit.

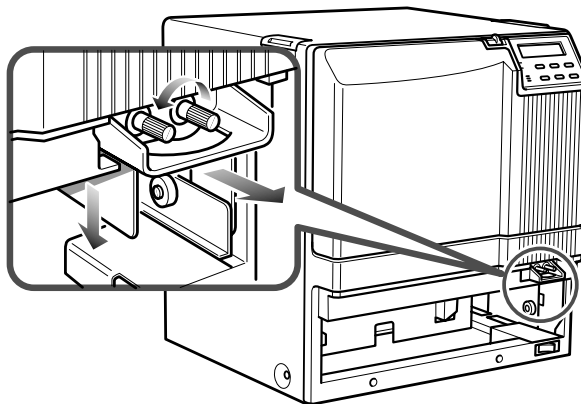

Turn the right knob to drop the jammed card. Remove the fallen card.

#### 3. Return the card tray to its original position.

Push the card tray back into position on an angle.

Push the card tray back into its position while placing the card tray tabs on the folded over metal plates.

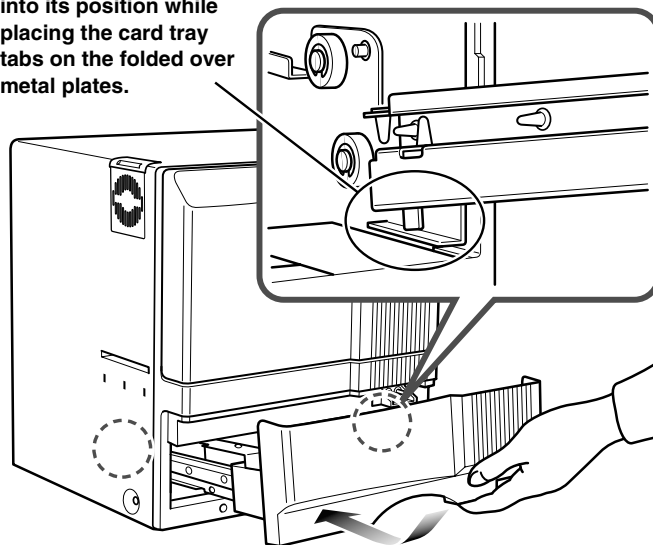

#### CAUTION

Pushing the tray with excessive force may cause a failure of the printer.

## Turnover section [Jam (turnover)]

1. Open the printer door and remove the ink ribbon cassette.

See p.14 in this manual.

2. Remove any jammed cards.

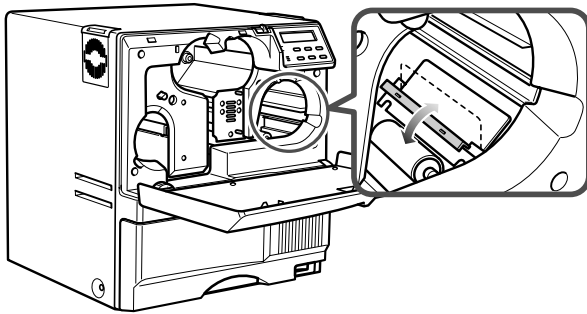

- If you can pull out the jammed cards, take them out.

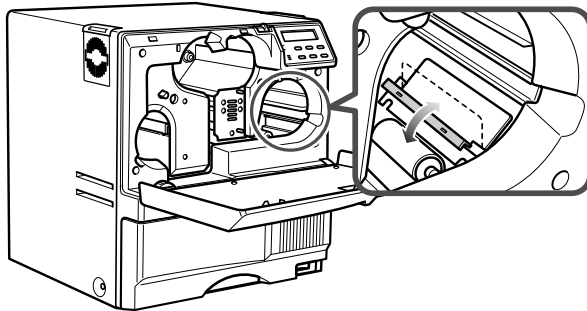

- If the jammed cards come out of the turnover table, push them back into the table, and rotate the table slowly (as it is positioned vertically) until the table is located so that the cards can be taken out.

### CAUTION



Injury

- When rotating the turnover table, be careful not to touch the metal edge. Wear a glove for this work.

## Retransfer section [Jam (transfer)]

1. Open the printer door and remove the retransfer film cassette.

See p.16 in this manual.

2. A jog lever are supplied as standard.  
The jog lever are attached to the center of the card tray.

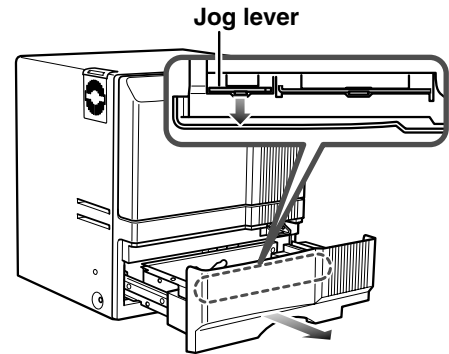

Turn the tabs in the arrow direction and take out the jog lever and removal stick.

3. Turn the jog dial.

Turn the jog dial with the attached jog lever.

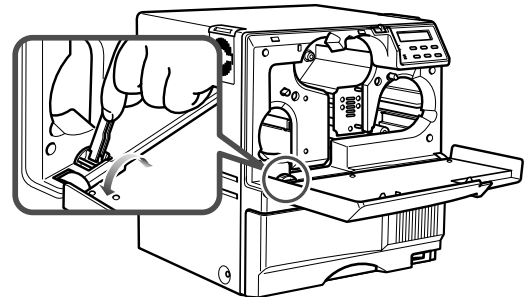

4. Remove the card.

Remove the card.

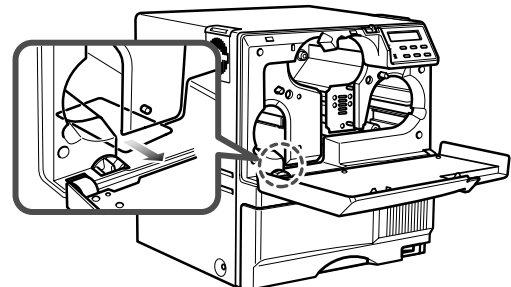

 **CAUTION** Some parts inside the printer may be hot. Be careful when removing the card.

# Specifications

## Main specifications

**Recording method** : Sublimation type retransfer  
**Feed format** : Automatic feed  
**Recording density** : 300 dpi  
**Expression gradation** : 256 gradations for each color  
**Printing time** : Approx. 29 seconds (for single-sided printing, excluding data transfer time)

**Interface** : Compliant with SCSI II (standard)

**Operating environment conditions**  
Temperature: 15°C ~ 30°C  
Humidity: 35% ~ 70% (no condensation)

**Storage environment conditions**  
Temperature: -15°C ~ 55°C  
Humidity: 20% ~ 80%

**Power supply** : 100~120ACV/220~240ACV (allowance±10%)

**Current dissipation** : 7.0A (for 100V system)/5.0A (for 200V system)

**Mass** : Standard 22kg  
Excluding the built-in magnetic encoder

**Accessories** : Power cable for 120ACV ..... 1  
Dark gray (North America)  
for 220 ~ 240ACV ..... 1  
(Europe)  
Cleaning card ×1  
Instruction manual English ×1  
Card stacker ×1  
Ink ribbon cassette ×1  
Retransfer film cassette ×1  
Ferrite core ×2  
(Standard model: 1 unit, built-in IC encoder model: 2 units)  
Binder ×4  
(Standard model: 2 units, built-in IC encoder model: 4 units)  
Jog lever (contained in the card tray) ×1

### CX21ICL Series (Large-type IC unit)

**Power supply** : Fed from the printer.  
DC 5V±5%, DC 12V±5%, DC 24V±5%

**Current dissipation** : 500mA, 300mA, 1A

**Mass** : 3.5kg

**Dimension (mm)** : 110(W) × 221(D) × 255(H)

**Accessories** : Joint plate × 1  
Inter-unit cable × 1

### CX21ICS Series (Compact IC unit)

**Power supply** : Fed from the printer.

**Mass** : 0.5kg

**Dimension (mm)** : 50(W) × 152(D) × 115(H)

**Accessories** : Screw (with washer) × 3  
Screw (without washer) × 2

Products sold separately : Compact IC unit  
: Ink ribbon, retransfer film Non-contact IC encoder  
1,000 frames/set

: Large-type IC unit  
: Cleaning card Mounts either a Non-contact or  
10 cards/set contact IC encoder.  
Model: CX210-CC1

The specifications and external appearance of this product are subject to change for improvements without a prior notice.

**External appearance and dimensions**

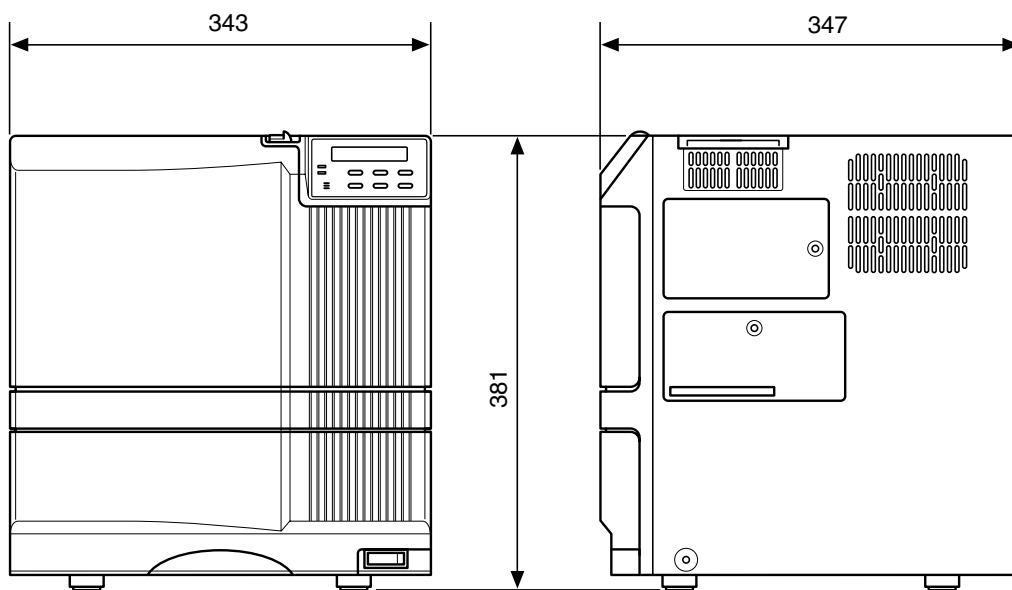

**Front view**

**Side view**

unit/mm





Ultra Electronics Card Systems  
Waverley House, Hampshire Road  
Granby Estate, Weymouth, Dorset DT4 9XD, UK  
tel: +44 (0) 1305 784 738 • fax: +44 (0) 1305 777 904  
email: UKsales@UltraMagicard.com

Ultra Electronics Card Systems  
6711 - 176th Avenue NE, Redmond, WA98052, USA  
Tel: (425) 556 9718 • Fax: (425) 556 3962  
email: USsales@UltraMagicard.com  
[www.ultramagicard.com](http://www.ultramagicard.com)



QUEENS AWARDS  
FOR INNOVATION  
2002

## Free Manuals Download Website

<http://myh66.com>

<http://usermanuals.us>

<http://www.somanuals.com>

<http://www.4manuals.cc>

<http://www.manual-lib.com>

<http://www.404manual.com>

<http://www.luxmanual.com>

<http://aubethermostatmanual.com>

Golf course search by state

<http://golfingnear.com>

Email search by domain

<http://emailbydomain.com>

Auto manuals search

<http://auto.somanuals.com>

TV manuals search

<http://tv.somanuals.com>