

Start Here!

1

2

3

Quick Start Guide - next page



DSS 2115

Digital Spread Spectrum

provides the longest range,

the clearest sound

and the best privacy.

QUICK START GUIDE

Uniden

INSTALLATION & SAFETY



This symbol indicates important operating and servicing instructions.

Choosing the best location for your DSS2115

When choosing a location for your phone there are a number of appliances the phone should not be near, and areas you should avoid.

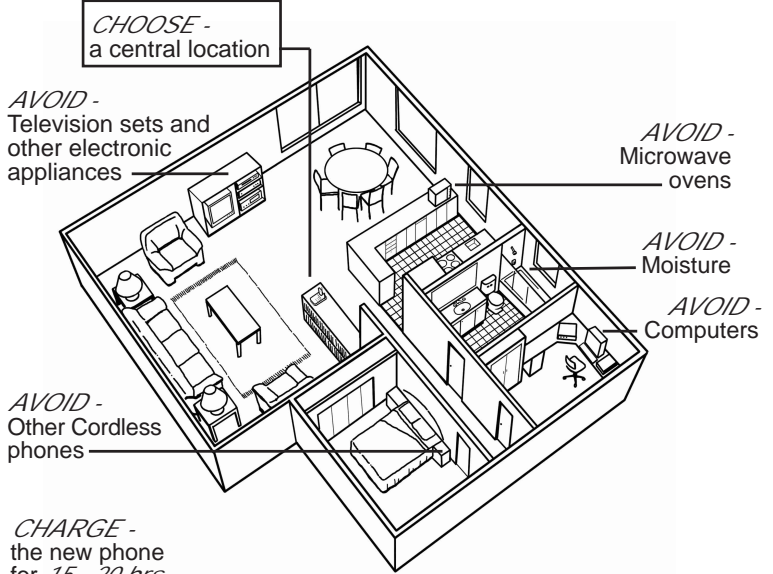

CHARGE - the new phone for 15 - 20 hrs and raise the antenna before making a call.

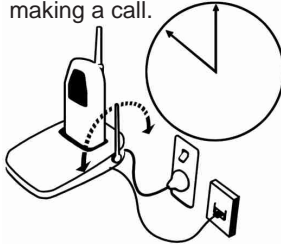

DON'T - overload the power outlet.

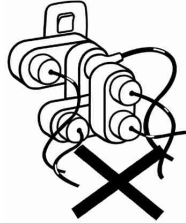

AVOID - moisture

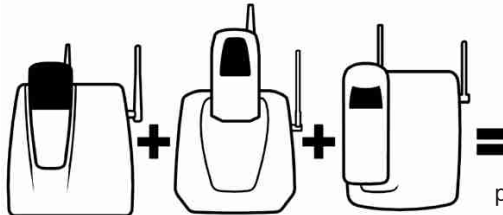

AVOID - Connecting more than

3 phones as Ringing may be impaired.

PRECAUTIONS

(i)

This page is a very condensed version of the Owners Manual. It is designed to allow you to get your phone installed and operating as quickly as possible - however it does not attempt to explain any of the advanced features of the DSS2115.

Start Here!

1

2

3

Quick Start Guide

1

Installing the Base Unit

- Plug the telephone cord into the Base Unit, then into the telephone socket on the wall.
- Plug the AC Adaptor cord into the Base Unit, then the AC Adaptor into the wall power point.
- Press the AC Adaptor cord into the curved recess under the Base Unit.
- Raise the antenna.

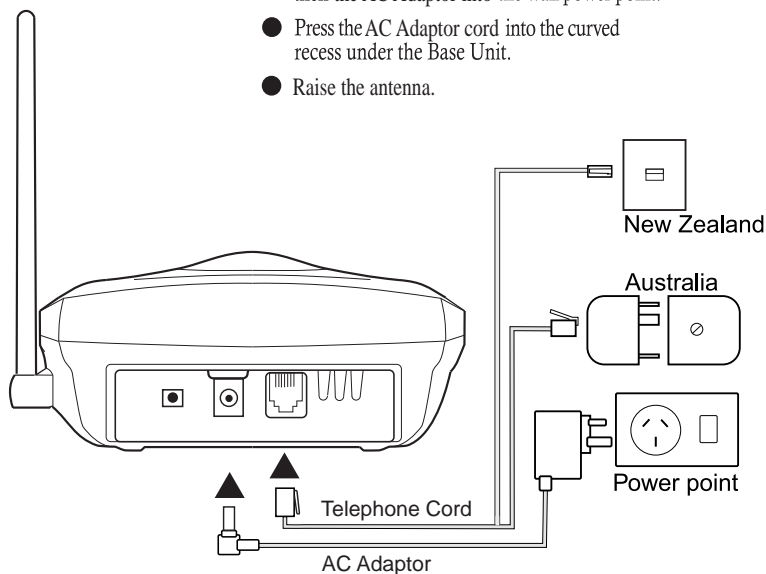

Make sure the AC Adaptor remains switched ON at all times.
Use only the Uniden AC Adaptor supplied with this unit.

(ii)



2

Installing the Handset Battery

- Press the battery cover and slide it off.

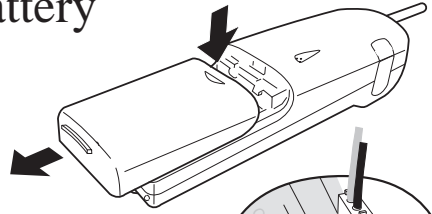

- Connect the battery plug to the socket at the rear of the battery compartment.

Make sure the plug is the right way round.

Press firmly until it clicks into place.

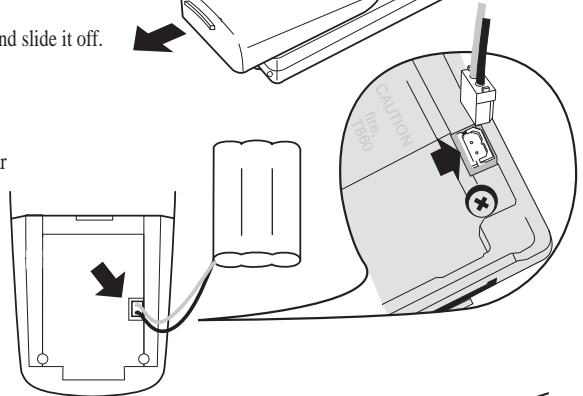

- Position the battery in the compartment and slide the cover into place.

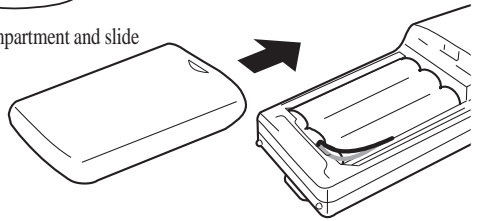

NOTE

Place the handset on the base Unit and charge it uninterrupted for 12 hours.

3

Making a Call

- Pick up the handset and press **talk**
Dial the phone number
OR
Dial the phone number - then press **talk**
- To hang up - press **talk**
OR
Place the handset on the base Unit.

Answering a Call

- **Handset on Base Unit:**
Remove the handset from the base and speak (Auto Talk).
- **Handset off the Base Unit:**
Pick up the handset, press **talk** and speak.
- **To hang up** - press **talk** again or place the handset on the base unit.

Storing a Number

Please refer to pages 10 & 11 for details of how to store numbers in your phone's memory and how to call stored numbers.

(iii)



CONTENTS

OF YOUR OWNERS MANUAL

Installation & Safety	i
Quick Start Guide	ii, iii
Contents	1
Controls & Functions	2, 3
Introduction	4
Welcome.....	4
Features.....	4
Included in your Package	4
Battery Maintenance	5
Battery use time (per charge).....	5
When the Battery Charge becomes Low.....	5
Cleaning the Battery Contacts.....	5
Adjusting the Ringer and Earpiece Volume.....	6
Installing the Belt Clip.....	6
Headset Installation.....	6
Using Your New Phone	7
Making and Receiving Calls.....	7
Call Transfer.....	8
Redialling a Call.....	8
Travelling out of Range.....	9
Keylock / Unlock.....	9
Call Waiting / Flash.....	9
Storing Phone Numbers and Names.....	10
Making Calls with Memory Dialing.....	11
Editing a Stored Name and Phone Number.....	12
Rocket Dial.....	12
Storing and Editing Rocket Dial.....	12
Making Calls with Rocket Dial.....	12
Erasing a Stored Name and Phone Number.....	13
Paging.....	13
Registration.....	14
Caller ID.....	15
Troubleshooting	18
Warranty	19

CONTROLS & FUNCTIONS

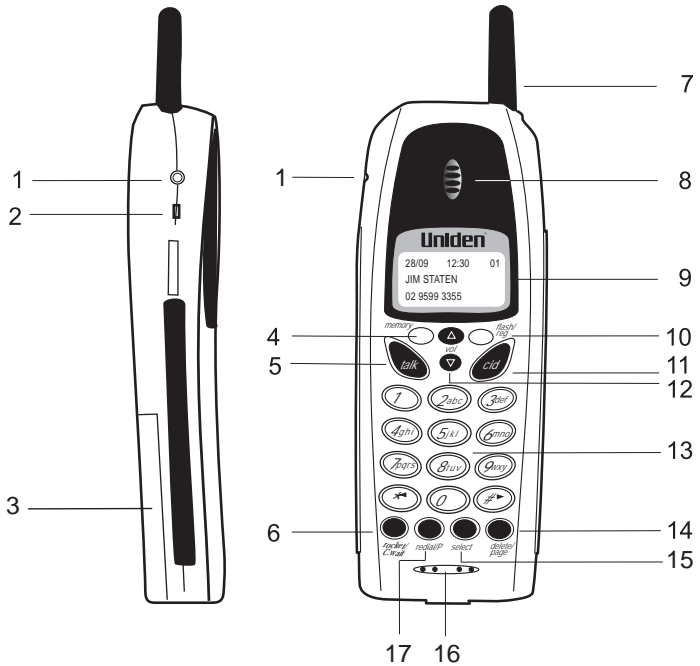

- | | |
|-----------------------|---------------------------|
| 1 Headset jack | 10 Flash/Registration key |
| 2 Belt clip slot | 11 CID key |
| 3 Battery compartment | 12 Volume control keys |
| 4 Memory key | 13 Alpha Numeric keypad |
| 5 Talk key | 14 Delete/Page key |
| 6 Rocket/C.Wait key | 15 Select key |
| 7 Handset aerial | 16 Handset Microphone |
| 8 Handset speaker | 17 Redial/Pause key |
| 9 Display screen | |

- 18 Charging contacts
- 19 Base unit aerial
- 20 In Use/Charge LED
- 21 Page key
- 22 Telephone line
- 23 DC In 9V
- 24 Registration key

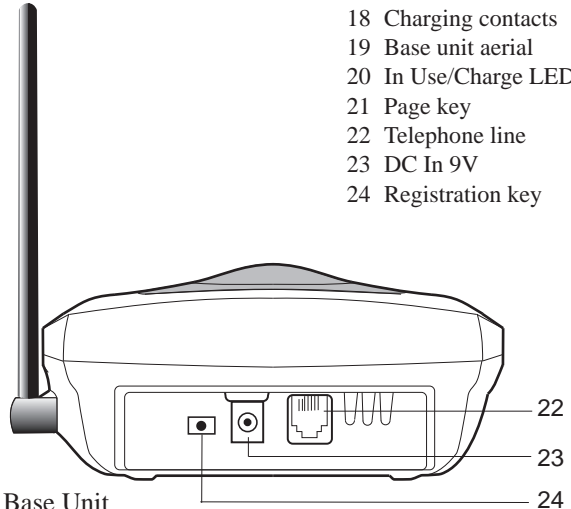

Rear of Base Unit

Top of Base Unit

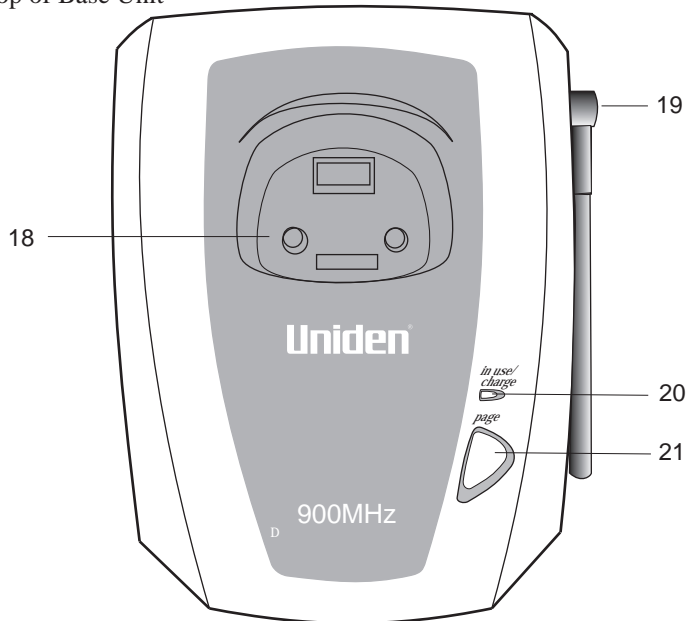

INTRODUCTION

TO YOUR NEW PHONE

WELCOME

Congratulations on your purchase of the Uniden **DSS2115** cordless telephone. This phone is designed for reliability, long life and outstanding performance utilising the latest in 900 MHz Digital Spread Spectrum Technology.

COMPANY PHILOSOPHY

To bring outstanding wireless communication products to people's lives throughout the world.

FEATURES

- 1 900MHz Digital Spread Spectrum Technology
- 1 Alpha display Caller ID
- 1 Multi Handset (capable of up to 7 handsets)
- 1 2 way Communication: Handset to Handset, without base.
- 1 Backlit LCD
- 1 Backlit Keypad on the Handset
- 1 POP ID - Caller Name Identification
- 1 60 Caller ID Memories
- 1 59 Alpha Memory Dialing
- 1 Maxi-Sound - Extra Loud Handset Volume Control
- 1 Rocket Dial - One Touch VIP Dial, One Touch Call Waiting
- 1 One Touch Call Waiting
- 1 32 Digit Redial
- 1 3 Redial Memories
- 1 Flash
- 1 Pause

INCLUDED IN YOUR PACKAGE

- 1 Handset
- 1 Base
- 1 Rechargeable Battery
- 1 AC Adaptor
- 1 Telephone Cord
- 1 Australian Telephone Cord Adaptor
- 1 Belt Clip
- 1 Owner's Manual
- 1 Consumer Support Card



NOTE

If any of these items are missing or damaged, contact your place of purchase.

BATTERY MAINTENANCE

NOTE

Use only the genuine Uniden Battery supplied with your phone. Replacement batteries are also available through the Uniden Parts Department.

NOTE

The built-in memory backup can hold numbers and names stored in the memory even if the battery pack is completely discharged.

Battery use time (per charge)

From fully charged

- 7.5 hours continuous use.
- 4 days when the handset is in the standby mode.
- A full charge will take at least 12 hours if Low Battery is displayed - however the phone will be ready for a short call after one hour.

When the battery charge becomes low

If the phone is not in use, Low Battery flashes and the keys will not operate if the phone is in use, Low Battery flashes and the handset beeps. Complete your conversation as quickly as possible and return the handset to the base unit for charging.

Low Battery

- You cannot over charge the battery.
- You may return the handset to the charger after each call or when the battery is low.

Genuine Handset Batteries

The high quality rechargeable batteries supplied with your phone perform for up to two years or more. In order to enjoy the best performance from your phone, we recommend you replace your batteries every two years with a genuine Uniden Battery.

Simply order a replacement battery from:

Uniden Australia PTY Limited

Service Division
Ph: 1300 366 895
www.uniden.com.au

Uniden New Zealand Limited

Service Division
Ph: 0800 4 UNIDEN (0800 4 864 336)
www.uniden.co.nz

Cleaning the battery contacts

To maintain a good charge, it is important to clean the battery contacts on the handset and base unit with a dry cloth or a pencil eraser about once a month.

Do not use any liquids or solvents.

ADJUSTING THE RINGER AND EARPIECE VOLUME

Ringer tone and volume

The phone has four ringer tone and volume combinations.

In the standby mode, press ▲ or ▼ on the handset repeatedly.

The display shows the setting.



RINGER A HIGH

Earpiece volume

Pressing ▲ or ▼ during a call will change the earpiece volume of the handset. The telephone will keep this setting for all calls and display the setting for each call.

Loud ⇨ High ⇨ Mid ⇨ Low



TALK LOUD 1

INSTALLING THE BELT CLIP

To attach the belt clip

- 1 Press the belt clip against the rear of the handset until it clicks into place.

To remove the belt clip

- 1 Gently pull one side of the belt clip to release.

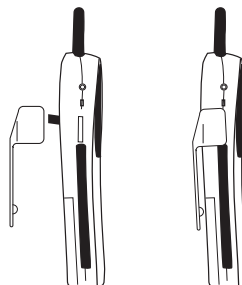

HEADSET INSTALLATION

Your phone may be used with an optional headset.

To use this feature, simply plug the headset into the headset jack.

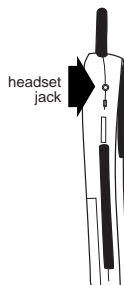

If you are using an optional headset, you must still use the handset keypad for phone operations.

MAKING AND RECEIVING CALLS

Basic phone operation

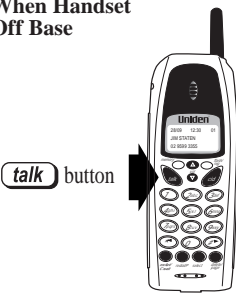
	When Handset On Base 	When Handset Off Base 
To answer a call (phone ringing)	<ol style="list-style-type: none"> 1. INCOMING CALL 2. Pick up handset. 3. TALK LOUD 1 <p>Auto talk answers the call as soon as the handset is picked up.</p>	<ol style="list-style-type: none"> 1. INCOMING CALL 2. Press talk. 3. TALK LOUD 1
To make a call	<ol style="list-style-type: none"> 1. Pick up handset. 2. Enter the phone number. 02 9599 3355 (example) 3. Press talk. 4. TALK LOUD 1 02 9599 3355 	<ol style="list-style-type: none"> 1. Pick up handset. 2. Enter the phone number. 02 9599 3355 (example) 3. Press talk. 4. TALK LOUD 1 02 9599 3355
To hang up	<p>Return the handset to the base (AutoStandby). or Press talk on the handset.</p>	<p>Return the handset to the base (AutoStandby). or Press talk on the handset.</p>

CALL TRANSFER

NOTE

If the called handset is not answered within 20 seconds, the call will return to the original handset.

During a call, you can transfer the call to another optional handset (maximum 7 handsets).

1. Press **(delete/page)**.
2. Press [handset No. (1)-(7)].
The handset number is shown on the right side of the display.
3. Press **(talk)**.
4. Called handset rings and call is transferred.

TRANSFER TO
HAND

REDIALLING A CALL

The last three phone numbers dialed can be quickly redialed.

Redial from standby

1. Press **(redial/p)**.
The most recent phone number that was dialed will be displayed on the screen.
2. Press **(redial/p)** again and the 2nd most recent number dialed will be displayed.
3. Press **(redial/p)** again and the 3rd most recent number dialed will be displayed.
4. Press **(redial/p)** to return to Standby.

Example: Press **(redial/p)**.

REDIAL 1
95993355

Most recent number dialed is displayed.

Press **(redial/p)** again.

REDIAL 2
95979012

2nd 'most recent number dialed' is displayed.

Press **(redial/p)** again.

REDIAL 3
95983577

3rd 'most recent number dialed' is displayed.

5. Press **(talk)** and the number will be dialed.

NOTE

If any key is pressed before pressing **(redial/p)** the last number dialed will not redial.



Only the last number dialed can be accessed after talk has been pressed.

Redial from talk mode

1. Press **(talk)**.
2. Press **(redial/p)** - the last number dialed will be displayed and redialed.

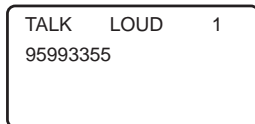
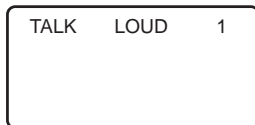

TRAVELLING OUT OF RANGE

During a call, noise will increase if you move your handset too far from your base unit. If the range limit of your base unit is exceeded, your call will terminate within 10 seconds.

KEY LOCK / UNLOCK

When the handset is in the standby mode, press and hold **(flash/reg)**, for 5 seconds, a beep confirms and the screen displays Key Locked. During the 'Key Locked' condition, the keys will only operate on an incoming call. To unlock the keys, press and hold **(flash/reg)** for 5 seconds again.

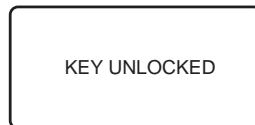
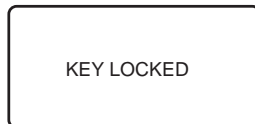

CALL WAITING / FLASH

If the Call Waiting tone sounds during a call -

Australia: Press **(rocket/c.wait)** or **(flash/reg)**, then **(2)** to switch between callers.

New Zealand: Press **(flash/reg)** to switch between callers.

STORING PHONE NUMBERS AND NAMES

NOTE

When storing a number, always include your area code (eg: 02), so name tagging will operate (refer page 15).

NOTE

The pause feature is useful for long distance calling, credit card dialing, or sequences that require a pause between digits.

Memory Dialing allows you to dial a number using just a few key strokes. You can store up to 59 phone numbers in the memory.

Since each step must be completed within 10 seconds, it may be advisable to review these instructions before starting.

1. Press and hold **(memory)** until MEMORY STORE is displayed.
2. Press **(▲)** or **(▼)** or enter a two digit number (**(0)** **(1)** - **(5)** **(9)**) to select the memory location where you would like to store the number.
3. Press **(select)** - STORE NAME is displayed and a cursor flashes indicating that the display is ready for the name to be entered.
If this screen appears, the selected memory location has a number already stored.
4. Use numeric key to enter the name.
The name cannot exceed 16 characters.
Use **(#▶)** and **(*◀)** to move the cursor to the next letter - or to create a space.
Use **(delete/page)** to delete characters as needed.
5. Press **(select)** - STORE NUMBER is displayed.
6. Use the number keypad to enter the phone number. It cannot exceed 24 digits.
Use **(redial/p)** to enter a pause. The screen displays P.
Each pause counts as one digit and represents one and half second delay in time between digits.
Use **(delete/page)** to delete digits as needed.
7. Press **(select)** - the handset beeps and displays the confirmation screen.
8. Press **(memory)** to return to standby mode or select another location to programme.

MEMORY STORE
01▶EMPTY
02 EMPTY

STORE NAME 01

STORE NUMBER 01

STORE NUMBER
0295993355

MEMORY 01 STORE

MEMORY STORE
01▶FRED
02 JOHN SMITH

MAKING CALLS WITH MEMORY DIALLING

Memory Dialling from Standby

1. Press **(memory)** once, the handset displays your programmed memory locations.
2. Press **(▲)** and **(▼)** or enter a two-digit number (**(0)(1)-(5)(9)**) to select the memory location you would like to dial.
3. Press **(talk)** - the displayed number is dialed.

```
01▶FRED
02 JOHN SMITH
03 KAY JONES
```

```
TALK LOUD 1
0295993355
```

Display a Memory Number or Name

Use **(#▶)** and **(*◀)** to toggle between the names display and the numbers display.

Program name

```
01 FRED
02▶JOHN SMITH
03 KAY JONES
```

(*◀)

(#▶)

Program number

```
01 0295993355
02▶0295738645
03 0205477631
```

Memory dialing from talk mode

1. Press **(talk)**
2. Press **(memory)**
3. Enter a two-digit number (**(0)(1)-(5)(9)**) to select the memory location of the desired phone number. The selected phone number is displayed. Then the number is dialed.

```
TALK LOUD 1
-
```

```
TALK LOUD 1
00182326634488-
```

Chain Dialing

On certain occasions after dialing a number, you may be requested to enter an access code, such as your account number for phone banking. You can enter this number into a memory location for later use by doing the following:

1. Store the access code into one of the memory locations (**(0)(1)-(5)(9)**) following the steps **STORING PHONE NUMBERS AND NAMES**
2. Dial the party or service main number.
3. When you need to enter the special number, press **(memory)** followed by the two digit memory location (**(0)(1)-(5)(9)**).

NOTE

When the stored phone number has 14 or more digits, **+** is displayed next to the 12th digit. Press **(#▶)** to see the extra digits and **(*◀)** to return.

EDITING A STORED NAME AND PHONE NUMBER

1. Press and hold **(memory)** until MEMORY STORE is displayed.
2. Press **(▲)** and **(▼)** or enter a two-digit number (**(0)** **(1)** - **(5)** **(9)**) to select the memory location you would like to edit.
3. Press **(select)** - the screen displays the memory location number you have selected.
4. Press **(▲)** or **(▼)** to select 'Edit Memory', then press **(select)**. The cursor flashes to indicate the display is ready for editing the name. When a name has not been stored, the cursor appears at the beginning of the second line.
5. Press **(# ▶) (✕◀)**, or **(delete/page)** to edit the name.
To edit only the phone number, skip this step.
6. Press **(select)** STORE NUMBER is displayed.
7. Use **(# ▶) (✕◀)** and the number keypad to edit the phone number.
The phone number cannot exceed 24 digits.
If you don't want to change the phone number, skip this step.
8. Press **(select)** - the handset beeps and displays the confirmation screen.
9. Press **(memory)** to return to standby mode or select another memory location to edit.

MEMORY STORE

01▶ FRED

02 JOHN SMITH

▶ EDIT MEMORY 01

DELETE MEMORY 01

GO BACK

STORE NAME 01

FRED

STORE NUMBER 01

0295993355

MEMORY 01 STORED

MEMORY STORED

01▶ FRED

02 JOHN SMITH

ROCKET DIAL

You can share your most frequently dialed number in the Rocket Dial location on each Handset. The Rocket Dial allows you to dial a number with one key press (there is no need to press **(talk)**). The phone will automatically dial the number stored).

STORING AND EDITING THE ROCKET DIAL

1. When the phone is in standby mode, press and hold **(rocket)** until a short beep is sounded.
2. Use the number keypad to enter or change the Rocket Dial number. It cannot exceed 24 digits.
3. Press **(rocket)** to save.

MAKING CALLS WITH ROCKET DIAL

When the phone is in the standby mode, simply press **(rocket)**. The number stored in the Rocket Dial memory location is instantly dialed.



NOTE

Memory location for the Rocket Dial is independent from memory location for Memory Dial.



NOTE

If the Rocket Dial does not have a stored number, the Handset will beep rapidly and the phone will not dial.



NOTE

You can not store a name to the Rocket Dial location.

ERASING A STORED NAME AND PHONE NUMBER

1. Press and hold **(memory)** until **MEMORY STORE** is displayed.
2. Press **(v)** and **(^)** or enter a two-digit number (**(0)** **(1)** - **(5)** **(9)**) to select the memory location you would like to edit.
3. Press **(select)** - the memory location number that you have selected is displayed
4. Press **(v)** to move the pointer down to the **DELETE MEMORY**.
5. Press **(select)** - the confirmation screen is displayed.
6. Press **(^)** to move the pointer to **YES**.
7. Press **(select)** - **MEMORY DELETED** is displayed.
8. After a few seconds the display returns to the **MEMORY STORE** screen. You may select another number to delete (return to step 2) or press **(memory)** to return to standby.

MEMORY STORE
01 FRED
02▶JOHN SMITH

▶EDIT MEMORY 02
DELETE MEMORY 02
GO BACK

EDIT MEMORY 02
▶DELETE MEMORY 02
GO BACK

DELETE MEMORY
▶YES
NO

MEMORY 02
DELETED

MEMORY STORE
02▶EMPTY
03 KAY JONES

NOTE

When an incoming call is received during paging, paging is cancelled and the telephone is switched to the incoming call.

NOTE

If additional handsets have been registered to the base, all handsets will beep when paged.

PAGING

Paging from base unit to the handset

Pressing the **(page)** button can help you to locate a handset's whereabouts.

1. Press **(page)** on the base.
2. The handset beeps for 60 seconds.
3. Press the **(delete/page)** button on the handset to end the page.

From handset to an optional handset

1. Press **(delete/page)** ⇨ [handset No. **(1)** - **(7)**].
The handset number is shown on the right side of the display.
2. The paged handset beeps for 20 seconds.
3. Press **(delete/page)** key on the paged handset to talk to each other.
4. To end the intercom, press **(delete/page)** again.
5. Both handsets go to standby.

PAGING

PAGING HAND 5

INTERCOM

REGISTRATION

NOTE

If a handset is registered at any time as handset 1, all other handsets will need to be registered again from Step 1.

TIP

If you have additional handsets, repeat the same process, but at Step 2 select a number from 3 - 7 to register the next handset as.

TIP

The Registration process needs to be completed within 15 seconds, 5 beep tones will indicate that the time has been exceeded. Please start the process again.

TIP

After Registration the handset number is shown on the Display screen either during a call or while the handset is charging (Fig 4).

The original handset supplied with the Main Base is already registered as Handset 1, this leaves Handset numbers 2 - 7 available. It is very important to allocate each handset a different number to enable functions such as Call Transfer.

Registration Process

Follow this process for each additional Handset (DSS2105) that needs to be registered to the Main Base or for registering your Main Handset.

1. Remove the handset from its charger
2. Press flash/reg on the handset (Fig 1).
3. Press the number 2 (Fig 2) for handset 2.

Fig 1.



Fig 2.

REGISTER AS
HAND #2

4. Place the handset in the Main Base Unit (Fig 3).
5. Press and hold the Registration button located on the back of the Main Base unit near the DC power jack (Fig 3). Hold the Registration button in until a long beep confirms the handset has been registered.

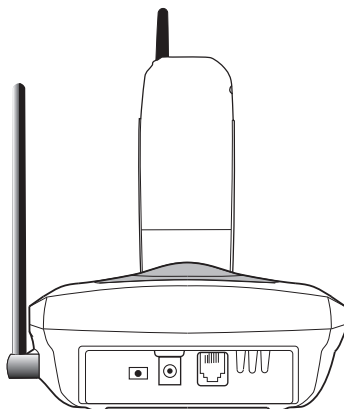
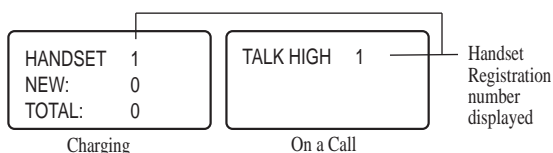

Fig 3.

Fig 4.



CALLER ID

NOTE

Caller ID information may not be displayed immediately.

You must subscribe to the Caller ID service from your local telephone company to use these features.

When the telephone rings, the Caller ID feature allows you to view the caller's name and phone number on the display before you answer the phone. The handset displays the phone number of the incoming call, the name, time and the number of calls. Additionally, you can dial the displayed number and store the information for memory dialing.

When the Telephone Rings

When the Caller ID message is received, the display shows the caller's phone number along with the date and time.

The incoming call information is stored in the Caller ID record. If the Caller ID service included the caller's name, the caller's name appears on the display (up to 15 letters).

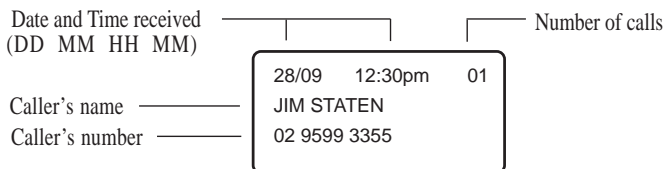

Some typical Displays:

When the phone number, name and date are received

28/09	12:30pm	01
FRED		
02 9597 9035		

When a private number is received

28/09	12:30pm	01
PRIVATE		

When an unknown number is received

28/09	12:30pm	01
UNAVAILABLE		

NOTE

Private numbers will not be recorded in the Caller ID list.

When a call is coming from overseas (New Zealand only)

28/09	12:30pm	01
OVERSEAS CALL		
000		

When a call is coming from a payphone (Australia only)

28/09	12:30pm	01
PAYPHONE		
UNAVAILABLE		

Name Tagging

If the displayed caller ID telephone number is **exactly** the same as a number stored in memory, then the stored name will also be displayed with the incoming Caller ID telephone number. Oversea's calls cannot be name tagged.

Viewing the Caller ID Message List

The Caller ID list stores information for up to 60 incoming calls—even unanswered calls.

1. Press **(cid)** - the summary screen is displayed.
The screen shows the number of new messages and total messages.
2. Press **(v)** to display the latest Caller ID message.
3. Press **(v)** to see the next message, or press **(u)** to see previous message.
4. Press **(cid)** again to return to standby.

HANDSET 1
NEW :1
TOTAL: 3

5/11 12:30 pm
FRED
02 9597 9035

Deleting Information from the Caller ID List

The DSS2115 stores up to 60 messages. If the phone receives the 61st message, the oldest one in the list is automatically deleted. Caller ID data can also be deleted manually.

Deleting a Caller ID message

1. Press **(cid)** - display the message to be deleted from the Caller ID list by pressing **(u)** or **(v)**.
2. Press **(delete/page)**.
3. Press **(u)** or **(v)** to indicate “Yes” or “No”.
4. Press **(select)**.

5/11 12:30 pm
FRED
02 9597 9035

DELETE MESSAGE?
YES
▶NO

When you indicate ‘Yes’ -

a tone sounds and the Caller ID message is deleted. The screen displays the next Caller ID message.

When you indicate ‘No’ -

a tone sounds and the display returns to the Caller ID screen.

Deleting all Caller ID names/numbers

1. Press **(cid)**.
2. Press **(delete/page)**.
3. Press **(u)** or **(v)** to indicate ‘Yes’ or ‘No’.
4. Press **(select)**.

NEW: 01
TOTAL: 03

DELETE ALL?
YES
▶NO

When you indicate ‘Yes’ -

a tone sounds and all stored Caller ID messages are deleted.

When you indicate ‘No’ -

a tone sounds and the display returns to the Summary screen.

TOTAL: 00



If a message has already been stored in the selected memory number location, a confirmation screen is displayed.

Press **(▲)** to indicate "Yes".

Press **(select)** to overwrite.

Using the Caller ID List

Calling a party from the Caller ID list

You can place a call from the Caller ID list. The DSS2115 stores up to 60 messages.

1. Press **(cid)** - select the phone number that you want to dial by pressing **(▲)** or **(▼)**.
2. Press **(talk)** - the displayed phone number will be dialed automatically.

Storing Caller ID messages in Memory dialing

The phone number of the party on the Caller ID list can be stored in memory dialing.

1. Press **(cid)** - select the phone number to be stored from the Caller ID list by pressing **(▲)** or **(▼)**.
2. Press **(memory)**.
3. Press **(▲)** or **(▼)** or enter a two-digit number **(0)** **(1)** - **(5)** **(9)** to select the memory location.
4. Press **(select)** - a confirmation tone will sound. The number is stored in memory, and the screen displays the Caller ID list.
5. To add a name to the stored number refer to page 16.

5/11 12:30 pm
FRED
02 9597 9035

TALK LOUD 1
0295979035

5/11 12:30 pm
FRED
02 9597 9035

SELECT LOCATION
01 ► FRED
02 JOHN SMITH

5/11 12:30 pm
FRED
02 9597 9035

REPLACE MEMORY
YES
► NO

TROUBLE SHOOTING

If your phone is not performing to your expectations, please try these simple steps first before calling Uniden customer service -

PROBLEM	SUGGESTION
No dial tone	Check that the phone line cord connectors at both ends are pushed in until they click.
Talk flashes No dial tone	Re-register the handset - see page 14
Does not ring	You may have exceeded the limit of the number of phones that can be connected to the same line, at the one time. Disconnect some telephones.
No power on the handset	Check the battery pack plug, inside the battery compartment of the handset, is fully pushed in. The handset rechargeable battery pack may need to be charged. Check the AC Adaptor is plugged in at both ends and switched On.
Does not charge	Make sure the charging contacts on both the handset and the base unit are in contact during charging. The charging contacts may need to be cleaned with a dry cloth or pencil eraser. Check the AC Adaptor is plugged in at both ends and switched On.
Range is limited	Make sure the base antenna is vertical. Move the base unit so that it is centrally located in your residence or office and make sure that the base unit is not located near electrical appliances.
Calls received, flutter or fade	The handset rechargeable battery pack may need charging. You may be out of normal operating range. Move closer to the base unit.



Please check our Website for the latest, up to date problem solving and frequently asked questions - Australia: www.uniden.com.au New Zealand: www.uniden.co.nz

WARRANTY

One Year Limited Warranty

Important: Evidence of original purchase is required for warranty service.

Warrantor: Uniden Australia Pty Limited ABN 58 001 865 498
Uniden New Zealand Limited

ELEMENT OF WARRANTY: Uniden warrants to the original retail owner for the duration of this warranty, its DSS2115 (hereinafter referred to as the Product), to be free from defects in materials and craftsmanship with only the limitations or exclusions set out below.

WARRANTY DURATION: This warranty to the original retail owner only, shall terminate and be of no further effect 12 months after the date of original retail sale. This warranty will be deemed invalid if the product is; (A) Damaged or not maintained as reasonable and necessary, (B) Modified, altered or used as part of any conversion kits, subassemblies or any configurations not sold by Uniden, (C) Improperly installed, (D) Repaired by someone other than an authorised Uniden Repair Agent for a defect or malfunction covered by this warranty, (E) Used in conjunction with any equipment or parts or as part of a system not manufactured by Uniden. (F) Only available in the original country of sale.

PARTS COVERED: This warranty covers for one (1) year, the Base/Charging Unit and Handset only. All accessories (AC Adaptor, battery etc.) are covered for 90 days only.

STATEMENT OF REMEDY: In the event that the product does not conform to this warranty at any time while this warranty is in effect, the warrantor at its discretion, will repair the defect or replace the product and return it to you without charge for parts or service. **THIS WARRANTY DOES NOT COVER OR PROVIDE FOR THE REIMBURSEMENT OR PAYMENT OF INCIDENTAL OR CONSEQUENTIAL DAMAGES. THIS GUARANTEE IS IN ADDITION TO AND DOES NOT IN ANY WAY AFFECT YOUR RIGHTS UNDER THE CONSUMER GUARANTEE ACT.**

PROCEDURE FOR OBTAINING PERFORMANCE OR

WARRANTY: In the event that the product does not conform to this warranty, the Product should be shipped or delivered, freight pre-paid, with evidence of original purchase (eg. a copy of the sales docket), to the warrantor at:

UNIDEN AUSTRALIA PTY LIMITED
SERVICE DIVISION
345 Princes Highway,
Rockdale NSW 2216
Ph (02) 9599 3577 Fx (02) 9599 3278
Ph: 1300 366 895

www.uniden.com.au

UNIDEN NEW ZEALAND LIMITED
SERVICE DIVISION
150 Harris Road,
East Tamaki, Auckland
Ph (09) 273 8377 Fx (09) 274 4253
Ph: 0800 4 UNIDEN
(864 336)

www.uniden.co.nz

Customers in other States should ship or deliver the Product freight pre-paid to their nearest Uniden Authorised Repair Centre. See Unidens Website for the nearest Repair Centre.

THANK YOU

FOR PURCHASING A UNIDEN PHONE!

Uniden

© 2003 Uniden Australia Pty Limited
Uniden New Zealand Limited

Free Manuals Download Website

<http://myh66.com>

<http://usermanuals.us>

<http://www.somanuals.com>

<http://www.4manuals.cc>

<http://www.manual-lib.com>

<http://www.404manual.com>

<http://www.luxmanual.com>

<http://aubethermostatmanual.com>

Golf course search by state

<http://golfingnear.com>

Email search by domain

<http://emailbydomain.com>

Auto manuals search

<http://auto.somanuals.com>

TV manuals search

<http://tv.somanuals.com>