

The background of the cover features dark silhouettes of a truck on the left and a car on the right. Both vehicles have long, thin antennas extending upwards. The truck's cab and the car's roofline are clearly visible against the white background.

uniden[®]

GRANT 40 Channel AM/SSB
Mobile CB Radio

OWNERS MANUAL

INTRODUCTION

UNIDEN CORPORATION OF AMERICA has combined superb workmanship and modern styling with the very latest state-of-art circuitry to bring you the GRANT Citizens Band Transceiver. It has been especially designed to give you maximum performance and reliability. Your GRANT is completely factory aligned and quality assurance tested.

To obtain the maximum benefit and pleasure from your GRANT, please read very carefully the contents of this manual before attempting to install or operate the transceiver.

WARNING

The Citizens Band (CB) Radio Service is under the jurisdiction of the Federal Communications Commission (F.C.C.). Any adjustments or alterations which would alter the performance of the transceiver's original F.C.C. Type Acceptance or which would change the frequency determining method are strictly prohibited. Replacement or substitution of Crystals, Transistors, IC, Regulator Diodes or any other part of a unique nature, with parts other than those recommended by us, may cause violation of the technical regulations of Part 95 of the F.C.C. Rules or violation of Type Acceptance requirements of Part 2 of the Rules.

ELIMINATION OF LICENSING

The Federal Communications Commission (F.C.C.) has ruled that Citizens Band (CB) Radio Service operators no longer are required to obtain an F.C.C. license to operate their CB equipment. In doing so, the F.C.C. also decided to permit CB station operation without station identification.

Elimination of individual station licenses results in no lessening of the operating privileges or responsibilities of CB users. An operator of a CB radio station is still required to comply with the Communications Act and with the rules of CB Radio Service.

INSTALLATION

MOBILE STATION INSTALLATION

Plan the location of the transceiver and microphone bracket before starting the installation. Select a location that is convenient for operation and does not interfere with the driver or passenger in the vehicle. The radio should be securely fastened to some solid face, using the mounting bracket and self-tapping screws which are provided.

MOBILE STATION ANTENNA

Since the maximum allowable power output of the transmitter is limited by the F.C.C., the antenna is a very important factor affecting transmission distance. It is for this reason that we strongly recommend that you install only a quality antenna in your new citizens band system. You have just purchased a superior transceiver. Don't diminish its performance by installing an inferior antenna.

Only a properly matched antenna system will allow maximum power transfer from the 50-ohm transmission line to the radiating element. Your UNIDEN dealer is qualified to assist you in the selection of the proper antenna to meet your application requirements.

For automobile installation, the whip antenna may be used with good effect. The most efficient and practical installation is a full quarter wave whip antenna mounted on the rear deck or fender top midway between the rear window and bumper.

A short "loaded" whip antenna is more convenient to install on your automobile, although the efficiency is less than a full quarter wave whip antenna.

For marine installation, consult your dealer for information regarding an adequate grounding system and prevention of electrolysis between fittings the hull and water.

GROUND INFORMATION

Most newer U.S. and foreign made cars and small trucks use a negative ground system, while some older cars and some newer large trucks may use a positive ground system.

A negative ground system is generally identified by the (-) battery terminal being connected to the vehicle motor block, but if you cannot determine the polarity system of your vehicle, it is suggested that you consult your vehicle dealer for definite information.

POWER CORD CONNECTION: NEGATIVE GROUND SYSTEM

If you are operating on a negative ground system, connect the red DC power cord from the transceiver to the positive, or (+), battery terminal or other convenient point and connect the black power lead to the chassis or vehicle frame, or (-) battery terminal.

POWER CORD CONNECTION: POSITIVE GROUND SYSTEM

If you are operating on a positive ground system, connect the black DC power cord from the transceiver to the negative, or (-), battery terminal or other convenient point, and connect the red power lead to the chassis or vehicle frame, or (+) battery terminal.

NOTE: With regard to the connection of the power cords, it may be possible or desirable to connect the (red lead for negative ground system) or (black lead for positive ground system) to the ignition switch accessory terminal so that the transceiver is automatically turned off when the ignition switch (key) is turned off.

Alternately, the power lead may be connected to an available terminal on the fuse block or even to a point in the wiring harness. Care must be taken, however, to guard against a short circuit condition. When in doubt, please contact your vehicle dealer for specific information for your vehicle.

BASE STATION OPERATION

To operate the transceiver from your home or office, using regular house current as the power source, you will require a separate power supply capable of supplying 3 amps at a 13.8V DC output with a nominal input voltage of 120 volts AC, 50/60Hz. Simply connect the red (+) and black (-) leads of the transceiver to the corresponding DC terminals of the power supply.

NOTE: Do not attempt to operate this transceiver by connecting directly to 117V AC. When an AC power supply is used with the transceiver for base station operation any Citizens Band beam, dipole, ground plane or vertical antenna may be used. A ground plane vertical antenna will provide the most uniform horizontal coverage.

OPERATING PROCEDURE

TO RECEIVE:

The GRANT operates on 40 AM channels, 40 Upper Side Band channels and 40 Lower Side Band channels.

When you receive the SSB signal in the proper mode (USB or LSB), audio sound may be either too high pitched or low pitched, indicating that your receiver may not be tuned to the exact same frequency as the transmitter to which it is listening. The GRANT is equipped with a Clarifier. By tuning the Clarifier, you can slightly change the frequency of the receiver so you get a normal tone.

1. Place the PA switch in CB function – by turning SQUELCH control clockwise, past click.
2. Turn the set on by turning the VOLUME CONTROL clockwise, past click.
NOTE: Microphone must be plugged in for receiver to operate.
3. Set the VOLUME CONTROL to a comfortable level.
4. Set the Mode Selector Switch to the desired mode.
5. Listen to the background noise from the speaker. Turn the SQUELCH CONTROL slowly clockwise, until the noise just disappears. The Squelch is now properly adjusted. The receiver will remain quiet until a signal is received. Do not advance the control too far, or some of the weaker signals will not be heard.
6. Set the Channel Selector to the desired channel.
7. Adjust the CLARIFIER to clearly receive SSB or AM signals.

TO TRANSMIT:

CAUTION

The transceiver Voltage Standing Wave Ratio (V.S.W.R.) measurement must be performed prior to the use of the transmitter. A.V.S.W.R. ratio in excess of 2:1 may damage the transmitter.

1. Be sure the operator has read and understands part 95, F.C.C. Rules and Regulations prior to operating the transmitter.
2. Select the desired channel.
3. If the channel is clear, depress the push-to-talk switch on the microphone and speak in a normal voice.

CONTROLS AND THEIR FUNCTIONS

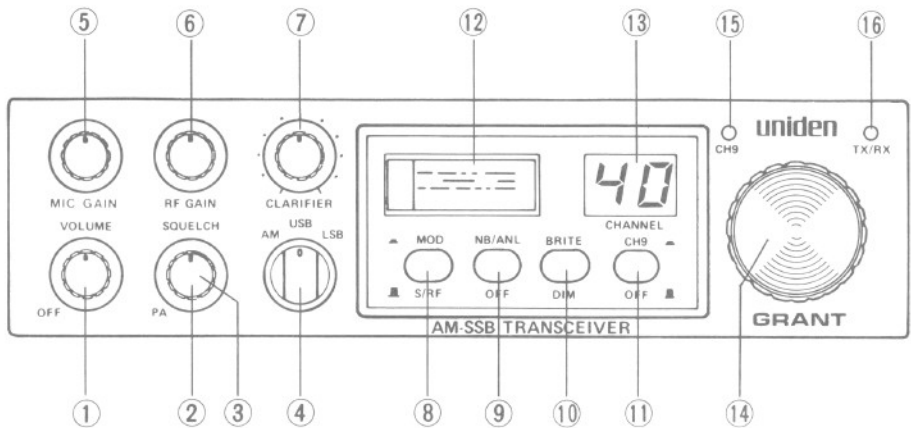

- 1. OFF/ON VOLUME:** To turn the transceiver on, rotate this control clockwise past click. To turn the transceiver off, rotate the control counterclockwise past click. Rotate the control clockwise for a comfortable audio level.
- 2. SQUELCH:** The Squelch control is normally set to a position which eliminates undesired background noise with no signal present. With the audio adjusted to a satisfactory level, rotate the Squelch control clockwise to the point where the sound from the speaker is cut off. In this position, there will be no sound from the speaker until a signal is received. In order to hear weak signals, it may be necessary to rotate the Squelch control counterclockwise, allowing some background noise to be heard.
- 3. PA SWITCH (on SQUELCH control):** Full counterclockwise rotation of the squelch control engages the PA function. The PA function should not be used unless an external speaker is connected. In the squelch (or CB) position, the PA function is disabled and the radio will transmit and receive on the selected channel.
- 4. MODE SELECTOR:** This switch selects AM, USB, or LSB mode of operation. This selector changes the mode of operation of both transmitter and receiver simultaneously. Set the selector to the mode on which you wish to communicate.

5. **MIC GAIN:** This control is used to adjust, as required, microphone input sensitivity for optimum amount of modulation in transmit. UNIDEN CORPORATION OF AMERICA citizen's band transceivers have been designed to permit the user to attain levels of modulation up to 100% depending on the setting of the microphone gain control, using the microphone provided with the unit. UNIDEN's automatic compression and peak limiting circuits assure maximum modulation with minimum distortion.
6. **RF GAIN:** This control is used primarily to optimize reception in strong signal areas. Gain is reduced by counterclockwise rotation of the control.
7. **CLARIFIER:** The clarifier control is normally set to the center position. This feature has several uses and can greatly enhance receiver operation. First, if a received signal is slightly off frequency, this control can be operated as required to optimize the receiver frequency. The effectiveness of this clarifier features under these conditions can be observed either by listening for a more readable signal at the speaker or by noting the S-meter reading when the clarifier control is operated. Another effective application of this control is in eliminating adjacent channel interference from strong signals. Operate this control, as required, to obtain minimum adjacent channel interference.
8. **METER MODE SWITCH:**
 - S/RF Position:** Meter indicates relative transmitter output power when transmitting, input signal strength when receiving.
 - MOD Position:** Meter indicates average percentage of modulation.
9. **NB/ANL SWITCH:** When the switch is placed in the NB/ANL position, both of RF Noise Blanker and Automatic Noise Limiter circuits are activated. The NB is very effective for repetitive impulse noise such as ignition noise. The ANL reduces most undesirable interference noises.
10. **DIMMER SWITCH:** This switch is used to adjust the brightness of the LED channel display and the meter. DIM position reduces brightness.
11. **CH9 SWITCH:** This switch is for use when emergency communication is needed on the emergency channel, CH9. Pressing the CH9 switch activates CH9 regardless of the position of the channel selector switch. When CH9 switch is pressed, the channel display is blanked and the CH9 indicator is activated.
12. **MOD—S/RF METER:** This meter displays relative transmitter RF output power and percentage of modulation when transmitting, as well as input signal strength when receiving. The meter is illuminated when power is on, the illumination can be adjusted by the DIMMER Switch for optimum brightness.

13. **CHANNEL INDICATOR:** Light Emitting Diode(LED) indicates the channel number in use.
14. **CHANNEL SELECTOR KNOB:** This knob selects the desired channel for transmission and reception. All channels, except channel 9, may be used for communications between stations. Channel 9 has been reserved by the F.C.C. for emergency communications involving the immediate safety of individuals or immediate protection of property. Channel 9 also may be used to render assistance to a motorist. This is an F.C.C. rule and applies to all operators of citizens band radios.
15. **CH9 INDICATOR:** Lights to show that the CH9 Switch has been activated.
16. **TX/RX INDICATOR:** This indicator lights red when the transmitter is in operation and lights green when the receiver is in operation.

RADIO BACK PANEL CONNECTORS

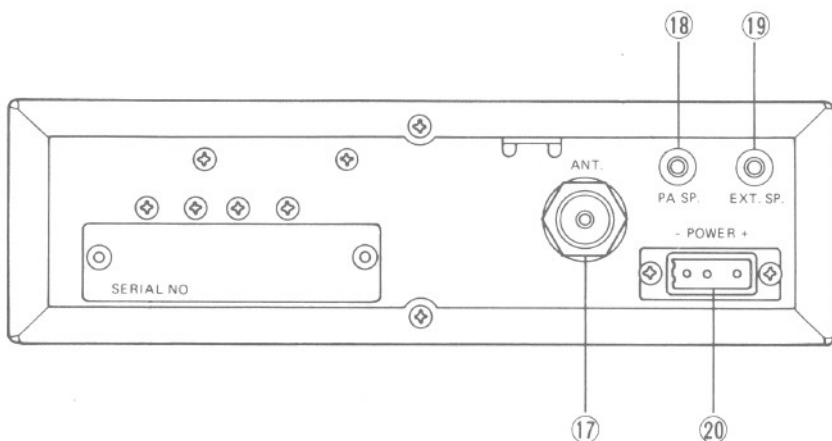

17. **ANTENNA CONNECTOR:** This female connector permits connection of the transmission line cable male connector (PL-259) to the transceiver.
18. **PUBLIC ADDRESS SPEAKER JACK:** An external 8 ohm 4-watt speaker must be connected to the PA SP jack located on the rear panel when the transceiver is used as a public address system. The speaker should be directed away from the microphone to prevent acoustic feedback. Physical separation or isolation of the microphone and speaker is important when operating the PA at high output levels.

19. **EXTERNAL SPEAKER JACK:** The External Speaker Jack is used for remote receiver monitoring. The external speaker should have 8 ohm impedance and be rated to handle at least 4.0 watts. When the external speaker is plugged in, the internal speaker is automatically disconnected.
20. **POWER JACK:** This jack permits connection of the D.C. power to the transceiver. A power cord is supplied with the radio.

SPECIFICATIONS

GENERAL

F.C.C. Type Number	1005002
Channels	40AM, 40LSB, 40USB
Frequency Range	26.965 to 27.405 MHz
Frequency Control	Phase Locked Loop(PLL) synthesized circuitry.
Frequency Tolerance	0.005%
Frequency Stability	0.001%
Operating Temperature Range	-20°C to +50°C
Microphone	Plug-in type; dynamic with push-to-talk switch and coiled cord.
Input Voltage	13.8V DC nominal, 15.9V max., 11.7V min. (positive or negative ground).
Current Drain	Transmit: AM full mod., 3A maximum. SSB, 12 watts PEP output, 3A maximum. Receiver: squelched; 0.5A, maximum audio output 1A.
Cabinet Dimensions	7-7/8"(W) x 2-3/8"(H) x 9-1/4"(D)
Weight	5 pounds
Antenna Connector	UHF, SO-239
Semiconductors	44 transistors, 3 field effect transistors, 6 integrated circuits, 62 diodes and 3 light emitting diodes.
Meter	Illuminated; indicates relative RF power output and modulation on Transmit, received signal strength.
Indicators	LED display; channel, emergency channel and TX/RX.

TRANSMITTER

Power Output	AM, 4 watts SSB, 12 watts, P.E.P.
Modulation	High and low level Class B, Amplitude Modulation.
Intermodulation Distortion	SSB: 3rd and 5th order, more than -25 dB. 7th and 9th order, more than -35 dB.
SSB Carrier Suppression	More than -45 dB.
Unwanted Sideband	More than -45 dB.

Frequency Response	AM and SSB: 350 to 2500 Hz.
Output Impedance	52 ohms, unbalanced.
SSB Filter	7.8 MHz, crystal lattice type 6 dB @2.2 kHz 60 dB @4.6 kHz

RECEIVER

Sensitivity	SSB: Less than 0.25 μV for 10 dB (S+N)/N at greater than $\frac{1}{2}$ watt of radio output. AM: Less than 0.5 μV for 10 dB. (S+N)/N at greater than $\frac{1}{2}$ watt of audio output.
Selectivity	SSB 6 dB @2.2 kHz, AM 6 dB @7.5 kHz.
Cross Modulation	More than 55 dB.
Image Rejection	More than 60 dB.
I.F. Frequency	AM: 455 kHz SSB: 7.8 MHz
AM and SSB RF Gain Control	Adjustable for optimum signal reception.
Automatic Gain Control	(AGC): Less than 10 dB change in audio out- put for inputs from 10 to 500,000 μV .
Squelch	Adjustable; threshold less than 0.5 μV .
Noise Blanker	RF type, effective on AM and SSB.
Clarifier Range	± 1.25 kHz.
Audio Output Power	3.5 watts minimum into 8 ohms.
Frequency Response	350 to 2500 Hz.
Distortion	Less than 10% at 3 watts output.
Built-in Speaker	8 ohms, round.
External Speaker (Not Supplied)	8 ohms; disables internal speaker when con- nected.

PA SYSTEM

Power Output	3.5 watts into external speaker.
External Speaker for PA	8 ohms (not supplied).

SERVICING YOUR TRANSCEIVER

The technical information, diagrams and charts will be supplied upon request. It is the user's responsibility to see that this radio is operating at all times in accordance with the F.C.C. Citizens Radio Service regulations. We highly recommend that you consult a qualified radiotelephone technician for the servicing and alignment of this CB radio product.

Please refer to the WARNING information contained in the 1st page of this Owner's Manual.

(NOTE: When ordering parts, it is essential to specify the correct model number and serial number of the unit.)

MAINTENANCE AND ADJUSTMENT

This transceiver is especially designed for the environment encountered in mobile installations. The use of all solid state circuitry and its light weight result in high reliability. Should failure occur, however, replace parts only with identical parts. Do not substitute.

PREVENTIVE MAINTENANCE

At six to twelve month intervals, the following system checks should be made:

1. Check Standing Wave Ratio (SWR).
2. Inspect all electrical connections to ensure that they are tight.
3. Inspect antenna coaxial cable for wear or breaks on shielding.
4. Inspect all screws and other mounting hardware for tightness.

ADJUSTMENT

This transceiver is factory aligned and should not require any adjustment when used with a 52 ohm antenna. If an antenna other than 52 ohm impedance is used, adjustment of the transmitter output circuit may be made to obtain optimum power transfer to the antenna. This adjustment should be made only by a licensed technician using a high quality in-line RF wattmeter which will not produce standing waves when inserted in the antenna cable.

OPERATOR TROUBLESHOOTING

Should the unit malfunction or not perform properly, the operator should perform the procedures indicated below:

1. If the transceiver is completely inoperative.
 - * Check the power cord and fuse.
2. If trouble is experienced with receiving.
 - * Check ON/OFF VOLUME CONTROL setting.
 - * Be sure SQUELCH is adjusted properly. Is the radio over-squelched?
 - * Check to see that the radio is switched to an operational mode.
3. If trouble is experienced with transmitting.
 - * Check to see that the transmission line (coaxial cable) is securely connected to the ANTENNA CONNECTOR.
 - * Be sure that the antenna is fully extended for proper operation.
 - * Be sure that all transmission line (coaxial cable) connections are secure and free of corrosion.

uniden

TWO-YEAR LIMITED WARRANTY

WARRANTOR. UNIDEN CORPORATION OF AMERICA ("UNIDEN")

ELEMENTS OF WARRANTY. UNIDEN warrants, for the duration of this warranty, its UNIDEN CB Product to be free from defects in materials and craftsmanship with only the limitation or exclusions set out below.

WARRANTY DURATION. This Warranty shall terminate and be of no further effect Two (2) years after the date of original purchase of the Product or at the time the Product is (a) damaged or not maintained as reasonable and necessary, (b) modified, (c) improperly installed, (d) is repaired by someone other than Warrantor for a defect or malfunction covered by this Warranty, or (e) used in a manner or purpose for which the Product was not intended.

PARTS COVERED. This Warranty covers all components of the Products.

STATEMENT OF REMEDY. In the event that the Product does not conform to this Warranty at any time while this Warranty is effective, Warrantor will repair the defect and return it to you prepaid, without charge for parts, service, or any other costs incurred by Warrantor or its representatives in connection with the performance of this Warranty. In addition, if the Product contains a defect or malfunction which is not repaired after a reasonable number of attempts by Warrantor to repair the Product, the Product or defective component will, at your election, either be replaced without charge or the purchase price for the Product will be refunded when the defective Product is delivered to Warrantor free and clear of all liens and encumbrances. Please note that while the Product will be remedied under this Warranty without charge.

THIS WARRANTY DOES NOT COVER OR PROVIDE FOR THE REIMBURSEMENT OR PAYMENT OF INCIDENTAL OR CONSEQUENTIAL DAMAGES.

Some states do not allow this exclusion or limitation of incidental or consequential damages, so the above limitation or exclusion may not apply to you.

WARRANTY REGISTRATION CARD. In order to facilitate the servicing of this Warranty by Warrantor, the Warranty Registration Card should be returned to Warrantor. However, return of the Warranty Registration Card is not a precondition of this Warranty, and this Warranty will be observed by Warrantor whether or not the Warranty Registration Card is returned, on the condition that other satisfactory evidence of the date of the original purchase is provided by Warrantor.

PROCEDURE FOR OBTAINING PERFORMANCE OF WARRANTY. In the event that the Product does not conform to this Warranty, the Product should be shipped prepaid to Warrantor. **THE ORIGINAL OR A COPY OF THE SALES RECEIPT OR OTHER VALID EVIDENCE OF THE DATE OF THE ORIGINAL PURCHASE MUST ACCOMPANY THIS PRODUCT.**

LEGAL REMEDIES. This Warranty gives you specific legal rights, and you may also have other rights which vary from state to state.

This warranty is void outside the United States of America.

uniden[®]
CORPORATION OF AMERICA

Personal Communications Division
4700 Amon Carter Boulevard
Fort Worth, Texas 76155

Free Manuals Download Website

<http://myh66.com>

<http://usermanuals.us>

<http://www.somanuals.com>

<http://www.4manuals.cc>

<http://www.manual-lib.com>

<http://www.404manual.com>

<http://www.luxmanual.com>

<http://aubethermostatmanual.com>

Golf course search by state

<http://golfingnear.com>

Email search by domain

<http://emailbydomain.com>

Auto manuals search

<http://auto.somanuals.com>

TV manuals search

<http://tv.somanuals.com>