



USE AND MAINTENANCE MANUAL

MISTBLOWERS AIRDROP - MFC[®]

**MOUNTED MISTBLOWERS
serie AIRDROP P- MFC P:
Ventagli - Minibar - Super Spalliera - RV-GDC**



Read this manual carefully before use.

Summary

1	USING AND KEEPING THE USE AND MAINTENANCE MANUAL	4
1.1	COMPOSITION OF THE MANUAL	4
1.2	GUARANTEE	4
1.3	PRODUCT RESPONSIBILITY	4
1.4	WARNING SIGNS IN THE MANUAL AND ON THE MACHINE	4
2	SAFETY REGULATIONS AND RESIDUAL RISKS	5
2.1	INTENDED USE	6
2.2	PROHIBITED USE	6
2.3	USING CHEMICAL PRODUCTS	6
2.3.1	REGULATIONS FOR THE USE OF CHEMICAL PRODUCTS	6
2.4	RECOMMENDATIONS	6
2.4.1	TAKING PRECAUTIONS AGAINST FIRE HAZARDS	7
2.5	WEATHER CONDITIONS	7
2.6	MACHINES DESIGNED TO BE USED ONLY WITH CLEAN WATER	7
2.7	DRIVING ON THE ROAD	7
3	CHARACTERISTICS AND SPECIFICATIONS	7
3.1	TABLES OF FITTINGS ALLOWED	7
3.2	NOISE LEVEL OF THE MACHINE	8
3.3	STANDARDS OF REFERENCE:	8
4	INSTRUCTIONS	8
4.1	DESCRIPTION OF THE MACHINE	8
4.1.1	WORK STATIONS	8
4.1.2	HAND WASHING TANKS	8
4.2	PRELIMINARY CHECKS	9
4.3	TRANSPORTING AND MOVING THE MACHINE	9
4.3.1	TOWED ATOMISERS	9
4.4	TRACTOR COUPLING	10
4.4.1	THREE-POINT COUPLING	10
4.4.5	HYDRAULIC CONNECTION TO THE DISTRIBUTORS	10
4.5	CARDAN SHAFT	11
4.6	PUMP	11
4.7	SUCTION FILTER	11
4.8	PRESSURE REGULATOR	12
4.8.1	COMPONENTS OF THE PRESSURE REGULATOR	12
4.8.2	GENERAL INSTRUCTIONS	12
4.8.3	DELIVERY FILTERS (ONLY EQUIPPED MODELS)	13
4.9	AUXILIARIES TAPS BLOCK	13
4.10	FILLING THE TANK	14
4.11	TEST WITH CLEAN WATER	14
4.12	MIXING	15
4.12.1	MANUAL PREMIXING	15
4.12.2	PREMIXER ON COVER (OPTIONAL):	15
4.12.2	PREMIXER ON COVER (OPTIONAL):	15
4.12.4	COVER WASHER FOR CHEMICAL CONTAINERS	15
4.13	WASHING THE ATOMISER	16
4.13.1	CIRCUIT WASHER AND TANK WASHER	16
5	BLOWER GROUP	17
5.1	MULTIPLIER - FAN UNIT	17
5.5	CLUTCH	17
5.3	DISTRIBUTOR ACCESSORIES	18
5.3.1	VENTAGLI (FANS) CANOPY, AND ESPALIER DISTRIBUTORS	18
5.3.2	MINIBAR FOR ESPALIER	18
5.3.2	SUPER SPALLIERA FOR ESPALIER	18
5.3.3	RV BOOM FOR GDC	19
5.4	HYDRAULICS	19
5.4.1	OIL FEED FROM TRACTOR	19
6	SPRAYING	20
6.1	DESCRIPTION OF THE DIFFUSERS	20
6.1.1	NON-DRIP VALVE	20
6.2	DESCRIPTION OF THE MFC® NOZZLES	20
6.3	MIXTURE CONCENTRATION	20
5	MISTBLOWER CALIBRATION	20

6.4.1	BATCHING TAPS (SEE PICTURE 20)	21
6.4.2	CALIBRATED PLATES CP	21
7	HAND LANCES	22
8	MAINTENANCE	22
8.1	PROGRAMMED MAINTENANCE	22
8.2	ROUTINE MAINTENANCE	22
8.2.1	CLEANING THE NOZZLES	22
8.2.2	LUBRICATION	22
8.2.3	MULTIPLIER LUBRICATION	23
8.3	EXTRAORDINARY MAINTENANCE	23
8.4	REPAIRS	23
8.5	STORAGE IN A WAREHOUSE AND TRANSPORTATION	23
8.6	PUTTING BACK INTO SERVICE AFTER WINTER LAYUP	23
8.7	DEMOLITION AND DISPOSAL	24
8.7.1	MATERIALS FOR DEMOLITION	24
8.7.2	INDICATIONS FOR A SUITABLE TREATMENT OF WASTE	24
8.7.3	ELECTRICAL AND ELECTRONIC APPARATUS WASTE (EEAW)	24
	TABLES FOR CALIBRATING AIRDROP 2 VENTAGLI (FANS)	25
	TABLES FOR CALIBRATING AIRDROP 2 VENTAGLI + TOP DIFFUSORS	26
	TABLES FOR CALIBRATING AIRDROP MINIBAR	27
	TABLES FOR CALIBRATING AIRDROP RV-GDC	28
	TABLES FOR CALIBRATING AIRDROP SUPER SPALLIERA	28
	TABLE 4-5 TABLES OF DELIVERY OF NOZZLES FOR HAND LANCES	29
	TABLE 7 TABLE OF PROGRAMMED MAINTENANCE	30
	TAB.18A ALLOWED FITTINGS	31

Thank you for having chosen UNIGREEN.

The product you purchased has been designed and built with the greatest attention to the safety of the operator and the environment, nevertheless there are still some residual risks due to the nature of the product used.

For this reason we recommend reading all of this manual to avoid making mistakes in the first period of use and to get the most out of the working life of the sprayer in time, doing the programmed maintenance at regular intervals.



1 USING AND KEEPING THE USE AND MAINTENANCE MANUAL

The manual is an integral part of the machine and should be kept in a safe place where it can be reached easily for consultation.

1.1 COMPOSITION OF THE MANUAL

This manual consists of various parts to make it easier to consult by subject and to avoid repetitions; the following are part of the manual:

- a) pump handbook
- b) pressure regulator handbook (manual or electric)
- c) spraying computer handbook (if fitted)
- d) optional accessories handbooks (marker, premix, cardan shaft, etc.)

UNIGREEN reserves the right to make changes to the manual without prior warning and the normal printing cycles may vary slightly.

1.2 GUARANTEE

The enclosed card indicates the conditions of the UNIGREEN guarantee. The UNIGREEN guarantee covers the repair or replacement of parts considered manufacturing flaws, according to the unquestionable judgement of UNIGREEN, only after the authorised agent for that zone has verified the fault.

Ambit of the guarantee

The guarantee doesn't cover cases of normal wear, negligent use, poor maintenance and/or improper use.

The following materials subject to normal wear are not covered by the guarantee: gaskets and seals, diaphragms, seal rings, tubes and pipes, nozzles, pressure gauges, oil, tyres, friction material of the clutches.

Evident cases of negligence include: work speed over that indicated in the spraying tables in the handbook (or too high for the conditions of the terrain), use of herbicide booms without an auto-levelling system or with the auto-levelling system blocked, power-takeoff speed over 540 rpm.

Mounted mistblowers: activation of the three-point elevator with cardan shaft engaged and power-takeoff operational.

And anything else indicated in the present Use and Maintenance Manual.

Maintenance:

The guarantee is void if the maintenance indicated in the tables in this manual isn't respected, regarding the period and deadline of the interventions, washing the machine and the circuit at the end of the treatment.

Improper use:

The use the UNIGREEN machines are designed for is indicated in this manual, any other use is forbidden and makes the guarantee void.

1.3 PRODUCT RESPONSIBILITY

UNIGREEN spa is not responsible if:

- a) During the working life of the machine the normal maintenance operations aren't performed and documented as indicated in this handbook, in the enclosed handbooks of the pumps-motors-regulators-etc. and in any case as is customary for the normal maintenance of mechanical machinery.
 - b) The machine is equipped with non original accessories or components or parts that aren't acknowledged by UNIGREEN as their own.
 - c) The machine is equipped with original accessories or components that are unsuitable in the measurements, weight or version for the same.
- Please consult the page of available and recommended fittings.
- d) Not following the instructions in the manual whether totally or partially.
 - e) Modifications made to the machine that haven't been authorised by UNIGREEN.

1.4 WARNING SIGNS IN THE MANUAL AND ON THE MACHINE

Below you will find all of the pictograms on the machine (see FIG.1 for their position), in order to illustrate the warnings, the prohibitions and the correct method of use.

The operations that require particular attention are shown in the images beside the text.



Composite handbook, consult the specific files on the various components



Key to the symbols

- 1- Read the Use and Maintenance manual
- 2- Stop the machine and read the manual before every intervention
- 3- Don't lubricate while running
- 4- Don't drink
- 5- Don't dispose of residue liquids in the environment
- 6- No smoking
- 7- Danger, risk or injury, don't get near the machine until the moving machine members have stopped
- 8- Danger of crushing, don't get your hands near the moving mechanical machine members
- 9- Danger, risk or injury caused by fluids under pressure
- 10- Don't climb on the machine during work or transfers
- 11- Don't climb on the tank
- 12- Don't enter in the tank
- 13- Wearing earmuffs is obligatory
- 14- Wearing a face mask is obligatory
- 15- Wearing safety footwear is obligatory
- 16- Wearing protective gloves is obligatory
- 17- Wearing protective overalls is obligatory
- 18- Use a working pressure under that indicated in red on the manometer.
- 19- Don't get your hands near the moving cardan shaft
- 20- Make sure power-takeoff of the tractor turns in the right direction and runs at the right speed.
- 21- Don't remove the protecting device with fan moving.
- 22- Material shooting off the machine, stand at a safe distance.
- 23- Don't stand between the machine and the tractor.

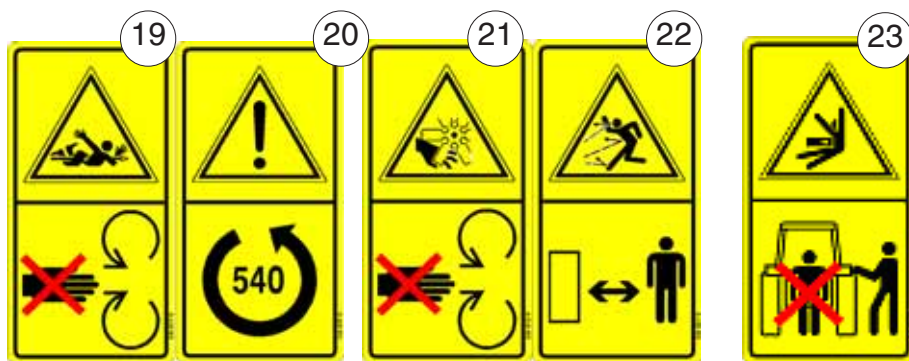

2 SAFETY REGULATIONS AND RESIDUAL RISKS

In relation to safety, the following terms will be used:

Dangerous zones: any zone inside and/or near the machine where the presence of a person exposed constitutes a risk for the safety and health of the same person.

Person exposed: any person who has their body or any part of their body in a dangerous zone.

Before starting the machine, the operator must check for any visible faults in the safety devices and the machine itself.

Never start the machine until you have told anyone in the range of action of the machine to move away and they have done so.

The protective devices must not be removed or disabled when the machine is running.

It is obligatory to keep all the plates with danger and safety signs in perfect conditions. If they get damaged or deteriorate, replace them in good time.

Replace parts believed to be faulty with others indicated by UNIGREEN. NEVER try makeshift or hazardous solutions.

Don't wear clothes, jewellery, accessories, or anything else that can get caught in the moving machine members.

Pay the greatest attention to all the warning and danger signs on the machine. Don't use the machine for any other purpose other than that indicated in the manual.

The machine has been designed and built with the appropriate devices to guarantee the safety of the user.

In any case there are some residual risks associated with the improper use of the machine by the operator; for this purpose danger signs and symbols and prohibitions are applied near some parts of the machine (see previous pictograms).

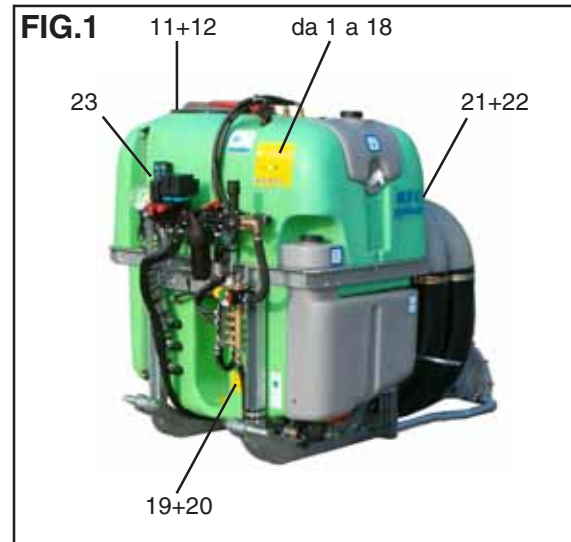

INDICATIVE POSITION OF THE WARNING SIGNS ON THE MISTBLOWERS

NB: the position may vary on the basis of the characteristics of the model.

2.1 INTENDED USE

The sprayer in this series is built for agricultural use. The materials used are resistant to normal chemical products used in agricultural spraying (or herbicides) at the time of construction.

Any other use is not allowed and the manufacturer is not responsible for any damage caused by aggressive, dense or sticky chemicals.

THE USE OF THE MACHINE BY PERSONS UNDER 18 YEARS OF AGE IS STRICTLY FORBIDDEN

The use of liquid fertilizers in suspension is not allowed, while the use of the same in a solution is possible if requested when the machine is ordered from Unigreen and in any case changing some of the parts described in the handbooks of the regulator, such as the manometer (stainless steel), the nozzles (large diameter ceramic) and eliminating the fine mesh filters to prevent blockages.

2.2 PROHIBITED USE

Using the machine with the following products is strictly forbidden:

- = Paints of any kind and type
- = Solvents or thinners for paints of any kind and type
- = Combustibles or lubricants of any kind and type
- = LPG or gas of any kind and type
- = Flammable liquids of any kind and type
- = Liquid foodstuffs, whether for animals or humans
- = Liquids containing granules or consistent solids
- = Mixtures of various incompatible chemical products
- = Liquid fertilizer or manure in suspension with lumps and/or that is particularly dense
- = Liquids with a temperature of over 40°C
- = Any products that aren't suitable for the specific use of the machine.

2.3 USING CHEMICAL PRODUCTS

All pesticides or herbicides can be dangerous to humans and the environment if used erroneously or inadvertently.

Therefore we recommend that only suitably trained persons should use these products (license) and in any case only after having carefully read the instructions on the container.



2.3.1 REGULATIONS FOR THE USE OF CHEMICAL PRODUCTS

Some recommendations for avoiding damage and accidents:

- = Keep the machine in a suitable, protected place with no access for children or strangers
- = Handle the products with care, wearing rubber acid-proof gloves, goggles- face masks or filtering helmets, overalls made of water-repellent fabrics or TIVEK and boots made of rubber or similar materials.
- = If chemical products or mixtures of product come into contact with the eyes or are swallowed consult a doctor immediately, taking the label of the product with you.
- = Wash all clothes that come into contact with the chemical, whether diluted or undiluted, thoroughly before using them again.
- = Don't smoke, drink or eat when preparing or spraying the mix or near or in the fields treated.
- = **DON'T ENTER THE TANK:** the residues of a chemical product can cause poisoning and suffocation.
- = When spraying, respect safe distances from residential areas, water courses, roads, sports centres and public parks or paths.
- = Thoroughly wash the containers of plant protection products using the relevant accessories, rinsing several times with clean water. The liquids used for washing can be used for treatment.
- = Collect the washed containers and send them to the relevant collection centres. Never dispose of them in the environment and don't use them again for any other purpose. It is good practice to knock a hole in the bottom of the tins so they can't be used again.
- = When you have finished spraying, wash the sprayer thoroughly, diluting the residues with a quantity of water at least 10 times that of the residues, spraying the resulting mix over the treated field.



2.4 RECOMMENDATIONS

- a) Refer to the present handbook for the use and maintenance of the frame, tank, auto-levelling systems, elevators, mechanical and hydraulic herbicide booms, spray booms and hose reels.

Refer to the enclosed handbooks for the use and maintenance of the pump and pressure regulator and any accessories or motors.

b) Please contact the agent in your zone, the nearest authorised workshop or UNIGREEN S.p.A. directly for any repairs the user feels they aren't capable of performing alone. (see point 8.4)

c) Due to the complexity of the equipment and the variety of technologies used (mechanical, hydraulic, oil-pressure and electrotechnical) operators must not dismantle or modify the equipment. All of the relevant operations must be performed by specialised personnel, authorised by UNIGREEN S.p.A.

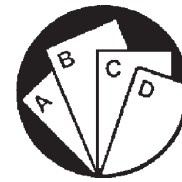

2.4.1 TAKING PRECAUTIONS AGAINST FIRE HAZARDS

Don't use naked flames or heat sources near the machines.

The mistblowers are made with many materials that derive from petroleum: tanks, tubes, pipes and hoses, wheels and plastic parts; furthermore the presence of oils of various nature and residues of chemical products make them potentially flammable.

2.5 WEATHER CONDITIONS

We recommend spraying in the early hours of the morning or late in the afternoon, avoiding the hottest time of day.

Never do any spraying if it's raining or rain is forecast.

Don't spray in strong wind or in any case, in winds above 3/5 m/second.

If you have to spray in windy conditions, use relatively low pressures to obtain quite large drops that are less sensitive to drifting (being heavier the wind has less effect). There are also special anti-drift nozzles available from UNIGREEN S.p.A.; for information, please contact our offices.

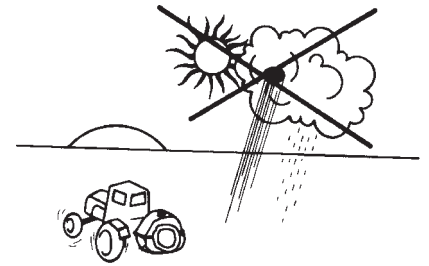

2.6 MACHINES DESIGNED TO BE USED ONLY WITH CLEAN WATER

There are versions of the machines designed only to be used with a hose reel for washing with cold clean water.

These machines cannot be used with chemical products as they don't have some of the devices or accessories that are needed to use these products safely.

These machines are identified by the word "washing" on the CE plate.

2.7 DRIVING ON THE ROAD

The towed mistblowers are not specifically designed for road use. Nevertheless, many models are also available in the version homologated for road traffic with the tank empty.

You should check with your local reseller on the correct couplings to use and use tractors that meet the regulations in force.

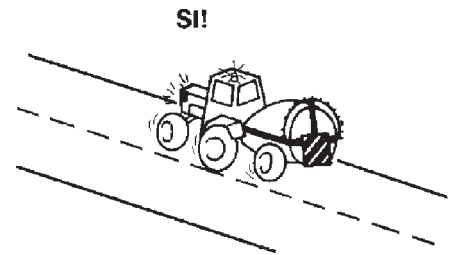

3 CHARACTERISTICS AND SPECIFICATIONS

This handbook is valid for mounted and towed mistblowers with axial fans for phytosanitary treatment in orchards and vineyards, in any case for arboreal cultivation in rows of varying nature and type.

It is also valid for cannon mistblowers for the phytosanitary treatment of tall plants and forest trees such as poplars or similar.

The axial mistblowers produce a mixed spray, breaking the drops with the pressure and the speed of the air produced by the fan.

These mistblowers produced by UNIGREEN SPA are identified by the CE plate (FIG. 2) bearing one of the marks indicated in the tables of the allowed fittings (see the following paragraph).

3.1 TABLES OF FITTINGS ALLOWED

Table N° 18a let you identify the version of your machine indicating the basic equipment and all the possible fittings available (optional).

You can also find the other fittings allowed or other versions to meet your requirements in the future.

THE EQUIPMENT DEFINED IN THE TABLES OF THIS HANDBOOK (TAB: 18a, page 31) SHOULD BE CONSIDERED BINDING FOR THE VALIDITY OF THE DECLARATION OF CONFORMITY.

Other fittings or setups of basic components and/or optionals should be considered unsafe and therefore are not covered by the guarantee and aren't UNIGREEN's responsibility.

The same goes for fittings realised with components or accessories that aren't original UNIGREEN parts.

UNIGREEN accessories can easily be identified by the label with the yellow background "ORIGINAL UNIGREEN ACCESSORY"

●	TYPE :	●
	code: N°	
	massa a vuoto:Kg. max press. : bar	
	net mass	
●	massa totale ammessa: Kg.	●
	total mass	
	unigreen S.p.A.	CE
	SPRAYING EQUIPMENT	ANNO YEAR
	via Rinaldi, 105 - Reggio Emilia ITALIA	20
		made in Italy

FIG.2



3.2 NOISE LEVEL OF THE MACHINE

Use earmuffs to protect your ears when using the machine, below you will find the data on the maximum noise levels during work.

Atomisers with centrifugal fan rotor (Airdrop)

ACOUSTIC POWER LEVEL emitted by the machine: **123,8 dBA** in 2nd gear

ACOUSTIC POWER LEVEL AT THE OPERATOR'S POSITION emitted by the machine: **103,2 dBA** in 2nd gear

Readings taken in accordance with the following standards:

Machines Directive 98/37/CE (Dir.89/392 CEE re-codified).

Legislative Decree D.Lgs. n°292 of the 4th of September 2002 concerning the environmental acoustic emission of machines and equipment for use outdoors.

Legislative Decree D.Lgs. 277/91 on the subject of the protection of workers against the risks deriving from exposure to chemical, physical and biological agents.

3.3 STANDARDS OF REFERENCE:

- MACHINES DIRECTIVE 98/37/CEE (Dir.89/392 CE Dir. re-codified).
- Directive 86/188/CEE: risks deriving from exposure to noise (implemented in Italy by Legislative Decree D.L 277/1991)
- DPR 547/1955: Regulations for the prevention of accidents and hygiene at work.
- Legislative Decree D.Lgs. n°292 of the 4th of September 2002 concerning the environmental acoustic emission of machines and equipment for use outdoors.
- UNI EN ISO 12100-1/Apr.2005 : Machinery safety - Fundamental concepts, general design principles - Part 1: basic terminology, methodology
- UNI EN ISO 12100-2/Apr.2005 : Machinery safety - Fundamental concepts, general design principles - Part 2: Technical principles
- UNI EN 294/July 1993: Machinery safety, safe distances to avoid reaching hazardous areas with upper limbs.
- UNI EN 349/June 1994: Machinery safety, minimum spaces to prevent crushing of body parts
- UNI EN 907/Nov.1998: Agricultural and forestry machinery - Sprayers and spreaders of liquid fertilizers - Safety.
- UNI EN 954-1/Dec. 1998 : Machinery safety - Fundamental concepts, general design principles
- UNI EN 982/July 1997: Machinery safety. Safety requisites relevant to systems and their components for hydraulic and pneumatic transmissions. Hydraulics.
- UNI EN ISO 4254-1/June 2006: Agricultural machines - Safety - Part 1: General requisites
- ISO 11684/1995: Pictograms - general principles.

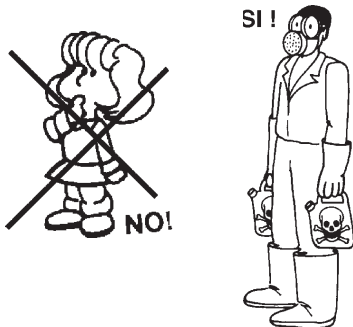

4 INSTRUCTIONS

To use the machine the personnel must be suitably trained on the basis of the regulations in force on safety and hygiene at work.

THE USE OF THE MACHINE FOR PERSONS UNDER 18 YEARS OF AGE IS STRICTLY FORBIDDEN

4.1 DESCRIPTION OF THE MACHINE

The mistblowers consist of a structural steel frame and a polyester tank reinforced with fibreglass or high-density polyethylene. The frame is hot-galvanised. The tank is easy to empty and this makes it possible to use the machine even on hillsides.

The pumps are generally diaphragm pumps but in some cases they are fitted with pistons.

The accessories for completing the fitting, non-drip jets and ceramic nozzles make the UNIGREEN mistblower a highly qualified and efficient piece of equipment.

4.1.1 WORK STATIONS

The use of this machine does not envisage an operator standing constantly near the same, the operator normally sits in the cab of the tractor.

During calibration and maintenance operations the operator will be working near the machine at ground level (for all the calibration and maintenance operations refer to the relevant chapters).

In some special models with controls above 1.5 metres there is a platform to make these operations easier.

This platform must only be used with the machine stopped.

4.1.2 HAND WASHING TANKS

The mistblowers are supplied with an auxiliary hand-washing tank with clean water and a hand tap.

This tank must always be supplied with water and the inside must be clean so you can wash any parts of the body that come into contact with the chemical product used.

Never drink the liquid inside.

Download from www.Somanuals.com. All Manuals Search And Download.



This symbol identifies the clean water tank on the machine used to wash your hands

4.2 PRELIMINARY CHECKS

When you receive the machine, check that it is complete and no parts are missing.

If there are any damaged parts, inform your local reseller or UNIGREEN directly in good time.

When the machine is delivered, make sure you ask:

a) that the machine is delivered with all of its parts fitted and that the fitting meets the requisites in table N° 18a (page 31).

This procedure is necessary because for reasons of space during transportation the machine is often delivered partially dismantled.

b) that it is tested in your presence in particular checking:

= that the suction filter and the inside of the tank are clean and free of work residues.

= that the connections are made correctly following the basic layout (FIG. N° 16, page 16).

= that the hose clips and all the unions and connections are tightened properly.

= that all of the protective covers are fitted solidly to the machine, in particular the protective cover of the power-takeoff of the pump.

= that the multiplier is sufficiently supplied with lubricant oil.

= that the zone where the fan turns hasn't been bent by knocks during transportation.

4.3 TRANSPORTING AND MOVING THE MACHINE

Every time you have to lift the machine, before starting the operation, always make sure the lifting gear and the relevant tools and equipment (cables, hooks, etc..) are suitable for lifting the load and check the stability of the same.

It is forbidden to unhook and move the machine with the tank full.

The dry weight of the machine at the maximum level of fitting and with all the accessories allowed is stamped on the nameplate (FIG.2); use slings and lifting gear with a adequate load-bearing capacity (FIG.3).

Never lift or move the mistblowers by hand if there is liquid in the tank. The machine will weigh more and the movement of the liquid can change the centre of gravity causing uncontrolled movements.

We recommend using slings as shown in the figure, the lifting points to use on the machine are indicated with the relevant symbol.

Don't lift the machine with the forks of a forklift truck because the machine can tip over due to the overhanging weight of the blower group.

Don't pass or stand under the machine when it is being lifted.

4.3.1 TOWED ATOMISERS

PARKING

Don't stand the atomiser on unstable ground or steep slopes, the machine is designed to be parked safely on compact ground with a slope of up to 8.5°

MOVING

To lift the machine, follow the instructions above.



This symbol identifies the coupling points of the machine

FIG.3

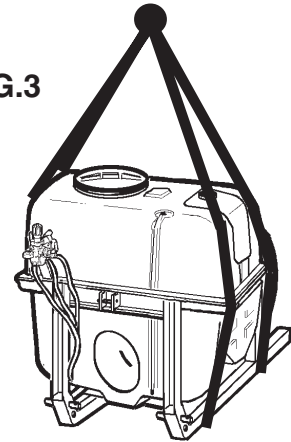

Only move and lift the machine with the tank empty

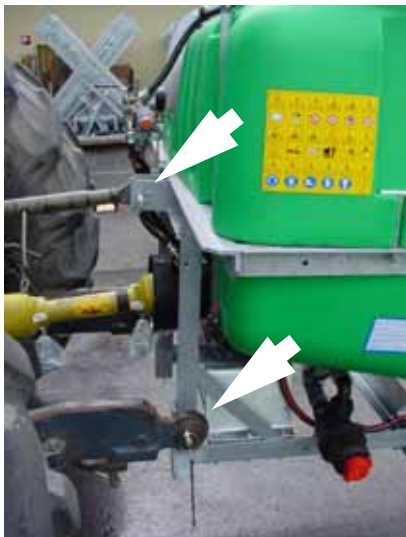

FIG.4

Tractor coupling

4.4 TRACTOR COUPLING

The tractor must have 1 3/8 ASAE DIN 9611/A power-takeoff that runs at 550 rpm. It must have a 3-point elevator suitable for safely supporting the weight of the atomiser.

Check this by consulting the table of allowed fittings N° 18a (pages 31).

WARNING: make sure there are no persons or things near the atomiser before starting the machine and while you are using it.

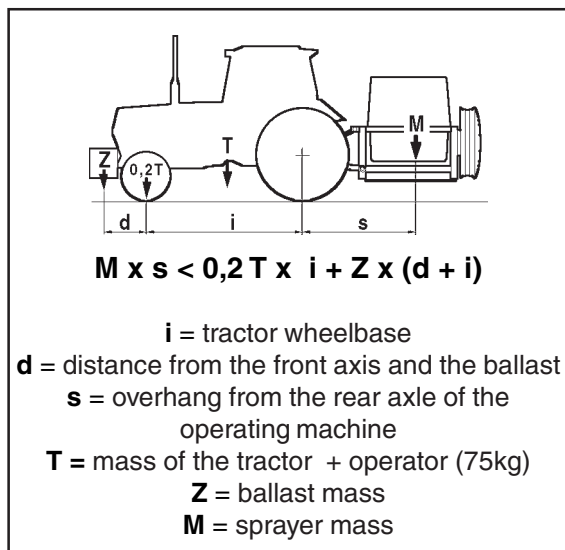

4.4.1 THREE-POINT COUPLING

a) We recommend carefully checking that the tractor is suitable for supporting the weight of the fully loaded sprayer safely.

The total weight of the sprayer with all of its accessories and fittings is indicated on the nameplate in FIG. 2 and also (in the version with the maximum fittings allowed) in tables N° 18a (pages 31).

For verification use the formula shown here.

Non-observance can result in a very dangerous situation as the tractor will lose steering sensitivity and can tip over when driving uphill or over bumps.

b) Check the diameter of the elevator coupling pins. If necessary position the double diameter pins correctly; there are also appropriate adapter bushes available.

c) Adjust the length of the third point tie-rod correctly so the sprayer is perfectly vertical in normal working position.

d) Check for the presence of the safety pins that stop the arms of the tractor jumping off the connecting pins.



4.4.5 HYDRAULIC CONNECTION TO THE DISTRIBUTORS

Machines that need a hydraulic connection to drive the movements of the cannon are equipped with 1/2", "Push-Pull", quick-fit male couplings. You can connect the pipes by simply pushing them in, making sure you:

- do so only with the engine turned off;
- lower any tools connected to the elevator of the tractor;
- carefully clean the two parts that will be coupled

Warning: the hydraulic cylinders used are the "Double Effect" type. Consult the use and maintenance manual of the tractor.

4.5 CARDAN SHAFT

In some models this is supplied on request.

The cardan shaft must bear the CE mark.

It must always have its own instructions that must be followed scrupulously and it should come with a cover bearing the mark, integrated in every part.

You should have previously checked the length to avoid:

- = if it is too long, DANGEROUS THRUST ON THE PUMP SHAFT
- = if too short, the POSSIBILITY OF DANGEROUS BREAKAGES

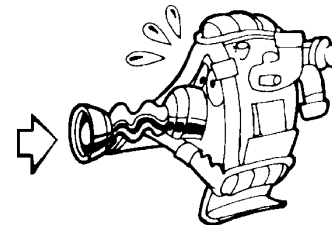
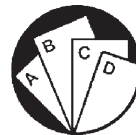

THE MINIMUM OVERLAP OF THE TWO TELESCOPIC TUBES MUST NEVER BE LESS THAN 1/3 OF THE LENGTH OF THE TUBES.

FIG. 6

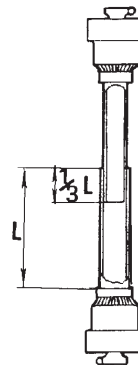
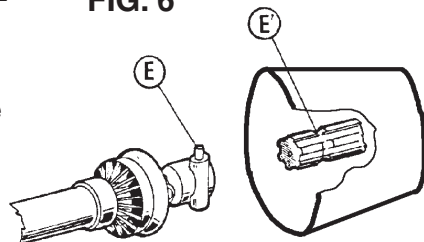
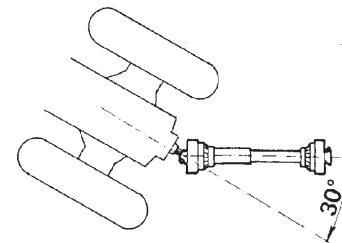

FIG. 7



The power that can be transmitted by the cardan shaft must be at least equal to that required to run the mistblower. These power ratings are indicated in tables N° 18a (page 31).

- a) Hook any safety chains to solid anchor points
- b) Check that the button or ringnut "E" (FIG. 6) is correctly engaged and blocked both on the pump side and on the tractor side.
- c) Don't exceed an inclination of 30° in any direction for any reason
- d) With the machine stopped, periodically grease the spiders and the pipes, keeping the connecting zone particularly clean.
- e) Avoid letting the end of the cardan shaft come into contact with the ground with the machine stopped; use the relevant support on some versions for this, if your machine has no support, hook the external safety chain to a part of the frame of the machine (ex. control unit support).
- f) For towed mistblowers with a steering drawbar, be very careful not to lift the arms of the elevator too high to prevent the cardan shaft touching parts of the drawbar.
- l) For towed mistblowers, avoid very tight steering circles with the cardan shaft turning (max 30°) as this could damage both the cardan shaft and the feet of the pump (FIG. 7).



NEVER USE THE CARDAN TRANSMISSION IF THE FOLLOWING PROTECTIVE COVERS ARE MISSING:

- TRACTOR POWER-TAKEOFF PROTECTIVE COVER
- CARDAN SHAFT PROTECTIVE COVER
- FIXED PROTECTIVE COVER ON THE PUMP SHAFT

4.6 PUMP

When using the pump scrupulously observe the instructions in the enclosed handbook supplied by the manufacturer.

The pump can be identified by the ratings plate on the same; the main data on the pressure and delivery are easy to find on this plate.

Normally the pumps mustn't exceed 550 RPM; a higher speed won't improve performance but there is a risk of compromising the life and safety of the pump.

There is a safety valve on the pump, calibrated to prevent overpressure. Don't tamper with this valve for any reason and don't block or obstruct the pipes connected to it in any way.



4.7 SUCTION FILTER

The sprayer is fitted with a suction filter with filter cartridges that have roughly a 50-gauge mesh, which is equivalent to a hole of 0.4 at 0.35 mm.

An efficient filter lets the sprayer work properly.

You should periodically check that the filter cartridge is clean, this check should be done more often if there are impurities in the liquid.

To inspect the filter cartridge wear rubber acid-proof gloves as the liquid in the filter can come into contact with your hands when you open the filter.

Don't perform this operation with the pump running as the depression produced blocks the cover preventing the removal.

Before removing the cover of the filter, make sure that the same is isolated from the tubing by unscrewing the relevant rear valve (FIG. N°8) or on the 3-way deviator (FIG. N° 10, page 14).

After washing the cartridge, reassemble the cover making sure you connect the same to the circuit again, using the valves described above in the opposite order.

WARNING!: Don't disperse the washing residues in the environment!!

FIG. 8

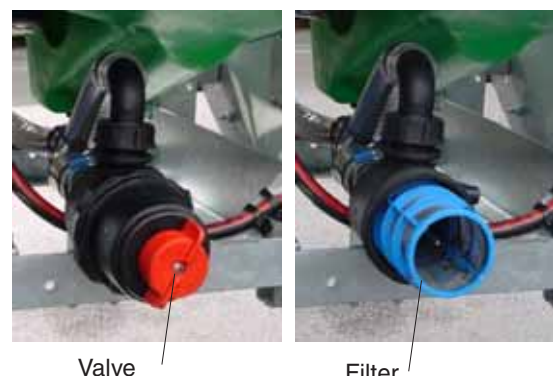



Don't use the sprayer without having consulted the enclosed handbook.

4.8 PRESSURE REGULATOR

To use the pressure regulator, follow the instructions in the enclosed handbook scrupulously. The pressure regulator controls all of the most important spraying functions, the thorough knowledge of its functions makes work easier and more precise.

The working pressure and the maximum pressure of the sprayer are determined by the pressure regulator which also protects the circuit from overpressure in any work conditions. (In serious but very rare cases, if the connecting pipes get blocked the pressure relief valve lets the pressure off) In some setups there may be a pump that can reach a pressure of 50 bar controlled by a regulator designed for 20 bar. In this case the maximum pressure that can be reached is 20 bar.

The regulators can be manual, mounted on the sprayer or at a distance to make the controls easier to use; or electrical with a control panel in the cabin. There are also regulator versions with mechanical remote controls with a cable. If the tractor has a waterproof cabin the use of electrical controls is obligatory.

4.8.1 COMPONENTS OF THE PRESSURE REGULATOR

Below you will find the indications for the main models fitted on Unigreen products.

A main ON-OFF command: "open" lets the fluid flow into the circuit in use; "closed" empties the tank.

B maximum pressure valve: adjusted by hand with the relevant knob (drains the excess liquid when the set pressure is reached).

C jets section tap: opens the corresponding jet boom or drains to the compensation regulator (G).

D auxiliary tap: can be used for various accessories (it is always manual).

E volumetric pressure valve (proportional):

(when present) it regulates the spraying pressure. The valve automatically compensates variations in speed (within the scope of the same gear ratio), keeping the quantity of liquid supplied per surface unit (litres/hectare) unchanged.

F self-cleaning filter: filters the delivery liquid.

G compensation regulators: suitably regulated, these make it possible to keep the pressure constant when one or more sections of jets is closed, they don't influence treatments with the boom fully open.

H manometer: indicates the working pressure.

Connections:

R1 supply union

R2 drain union

R3 volumetric drain union

R4 jets section delivery union

R5 auxiliary delivery union

Control box for GCP ELETTRICO electrical regulators

I1 main control valve switch

I2 volumetric pressure valve switch (proportional)

I3 jets section valves switches

4.8.2 GENERAL INSTRUCTIONS

When using the pressure regulator, scrupulously observe the instructions in the enclosed handbook, below you will find generic indications for the major models fitted by Unigreen.

All the regulation and adjustment tests must be carried out with clean water.

Pressure regulators without a volumetric valve (GCP3-way - GRH-RVA)

Adjusting the maximum pressure valve

= put main control **A** in the drain position ("OFF").

= loosen the hand wheel of maximum pressure valve **B** completely (anticlockwise).

= start the pump by activating the power-takeoff of the tractor at 540rpm

= open main control **A** (position "ON"), the manometer will be activated

= open all of the section valves **C** (position "ON")

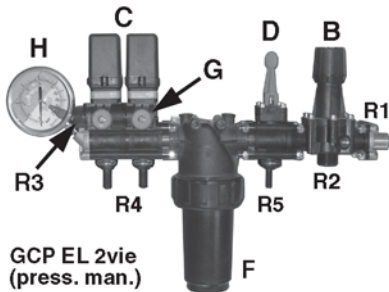

GCP EL 2vie
(press. man.)

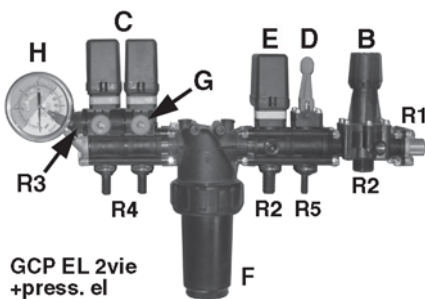

GCP EL 2vie
+press. el

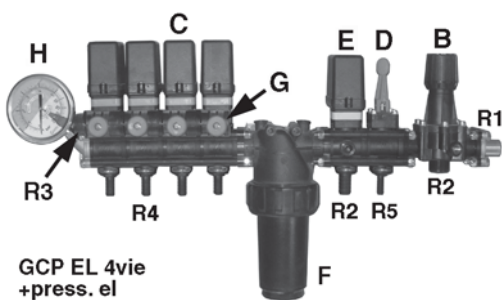

GCP EL 4vie
+press. el

= adjust maximum pressure valve **B** to the working value (in any case less than the safe maximum pressure the system can reach).

Pressure regulators with a volumetric valve (GCP ELETTRICO)

Adjusting the maximum pressure valve

- = put main control **A** in the drain position ("OFF").
- = loosen the hand wheel of maximum pressure valve **B** completely (anticlockwise).
- = open volumetric valve **E** completely.
- = start the pump by activating the power-takeoff of the tractor at 540rpm
- = open main control **A** (position "ON"), the manometer will be activated
- = open the drain tap on filter **F** slightly (only **GCP ELETTRICO**).
- = close volumetric valve **E** completely. If the pressure rises over the maximum limit of the system, make sure maximum pressure valve **B** is open (see previous indications)
- = open all of the section valves **C** (position "ON")
- = adjust maximum pressure valve **B** to a value over that of the working pressure (generally 10-14bar) and in any case lower than the safe maximum pressure that the system can reach.



Adjusting the volumetric pressure.

- = with the volumetric pressure valve **E** adjust the pressure to the value the treatment will be done at (the pressure is indicated on the nozzles tables on the basis of the tractor speed and litres/hectare to spray)

Warning! The working pressure must be adjusted with the volumetric valve and not with the maximum pressure valve. In the case the working pressure is too near to the calibrated pressure of the maximum pressure valve, the proportional valve may not be able to compensate the speed variations correctly.



Adjusting the compensated returns

- = close only one tap of section **C** (position "OFF").
- = adjust the corresponding compensator **G** until you return to the pressure set previously (displayed on the manometer).
- = open and close the tap of section **C** and check that the pressure remains constant.
- = repeat the above operations for all the section taps.

If the types of nozzles aren't changed the regulations carried out will guarantee a constant spraying of the liquid also per treatments that are done at different working pressures.

NB: if the type of nozzle is changed then the calibrating will have to be done again.

4.8.3 DELIVERY FILTERS (ONLY EQUIPPED MODELS)

This is particularly useful when using small nozzles (low volume), they are normally mounted on the jet booms and have a filter cartridge with a 40-gauge mesh (the equivalent of a 0.4 mm hole).

At the end of each treatment cycle you should clean the cartridge: turn the jets to the closed position, put the command under pressure and open the tap under the filter to drain the tank for a few minutes.

You should clean the cartridge by hand periodically, on the basis of the product used. Stop the pump to clean. Wear rubber gloves and the other personal protective equipment when cleaning.



4.9 AUXILIARIES TAPS BLOCK

A collector is installed (FIG. 9) in the Airdrop machines with taps for the utilities and accessories, which require a working pressure that is independent from the spraying pressure:

- Tank washing jet: see paragraph 4.13.1
- Ejector: see paragraph 4.10
- Agitators (2 independent taps): see paragraph 4.12

The taps are identified by the relevant sticker and the methods of use are described in the paragraphs indicated.

The pressure is normally regulated to 30-35 bar with the relevant valve (using a yellow knob) and displayed on the manometer installed; opening the utilities makes the pressure drop.

FIG. 9



Tank rinsing

Ejector

Agitator 1

Agitator 2

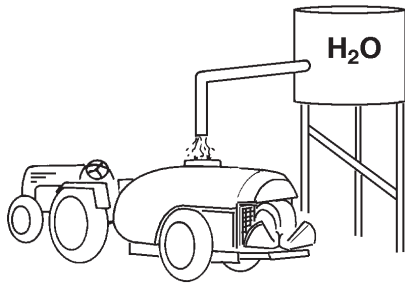

FIG. 10

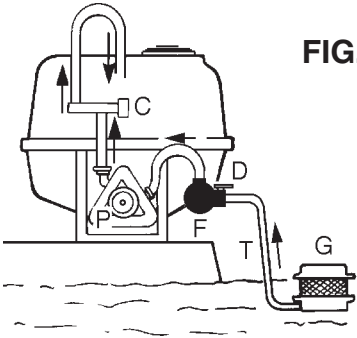
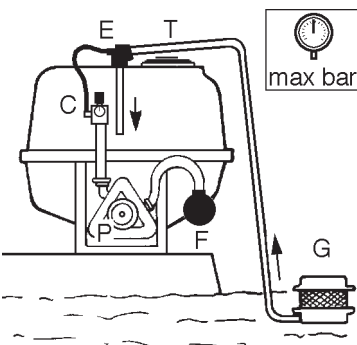

FIG. 11



FIG. 12



WARNING: using the taps on the pump or in any case on the front of the machine puts the operator near the cardan shaft. Despite the presence of CE standard protective covers you should take great care.

4.10 FILLING THE TANK

The machines for defensive crop treatments, in consideration of the safety of persons, animals and the protection of the environment, must only be filled indirectly from open water courses and only by free-falling water from the waterworks.

The pipe used for filling must never come into contact with the liquid inside the tank and therefore the water must always fall over the upper edge of the filling inlet and through the filter installed on it.

The tank is fitted with a transparent graduated band that shows the exact quantity of liquid inside. This reading is precise if the tank is on flat ground; the actual total capacity coincides with the highest number. All the filling systems fitted by Unigreen on their production machines or on request are antipollution and stop the liquid overflowing out of the tank.

a) FILLING WITH THE 3-WAY DEVIATOR (Fig. 10- Fig. 11).

It is possible to fill the tank using the pump and the floating filter kit **G** (cod.1002/0080F) with 6 metres of rubber hose (the floating filter lets you always and only suck up clean water).

- = connect hose **T** to deviator **D** using the union hose adaptor supplied.
- = turn the lever of deviator **D** to the filling position.
- = place the other end of the hose, on which you fitted filter **G**, in the watering point.
- = start the power-takeoff leaving pressure regulator **C** in the draining position (you don't have to put the pump under pressure).
- = the filling speed in litres/minute is equal to the delivery of pump **P**.
- = visually check the level of the liquid in the tank and after filling stop the pump and put the lever of deviator **D** back in the working position.
- = disconnect pipe **T** from deviator **D**.

b) FILLING WITH THE SUCTION FILTER (Fig. 3- Fig. 11).

If the 3-way deviator isn't fitted you can fill the tank using the coupling on the cover of the suction filter. Unscrew the rear wing nut of the filter and using a G1"1/2 threaded union, connect pipe **T** with the floating filter to the coupling. Also in this case the filling speed in litres/minute is equal to the delivery of the pump.

c) FILLING WITH THE ANTIPOLLUTION EJECTOR (Fig. 12)

If you are filling with an antipollution hydroejector (mounted as standard on some models) then you should proceed as follows:

- = put roughly 20-30 L of water in the tank and start the pump.
- = remove the cap of ejector **E** and insert filling pipe **T**.
- = place the other end of the hose, on which you fitted filter **G**, in the watering point.
- = open the tap that supplies the ejector (on auxiliary taps, see point 4.9).
- = increase the pressure until it reaches a value which is sufficient to suck up the liquid.
- = visually check the level of the liquid inside the tank and after filling disconnect pipe **T** from the ejector, close the tap and replace the cap.

4.11 TEST WITH CLEAN WATER

It is good practice to do a test with clean water (without chemical product in the tank) before the first treatment to make sure the mistblower is working properly and to get to know the controls. For instructions on how to proceed with the treatment see the chapter **SPRAYING**.

4.12 MIXING

The active principle can be mixed using the relevant stirrers before and during the treatment. Correct mixing and stirring is the basis of the correct distribution on the crops. We recommend some useful accessories such as the premixer for powders and liquids (see the following paragraph).

The machines in the Airdrop-MFC range can be equipped with 2 hydro-pneumatic agitators, supplied by the relevant taps in the auxiliaries taps block (paragraph 4.9).

o mix the product in the tank run the stirrer (or ejector) for roughly 10-15 minutes at the maximum pressure available

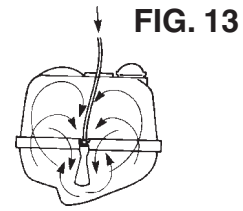

4.12.1 MANUAL PREMIXING

Dilute the active principle by hand before introducing it into the tank, (you must wear suitable protective clothing such as rubber gloves, a mask or goggles, overalls, etc.).

WARNING: the indications to follow for using chemical products are indicated in paragraph 2.2.1.

4.12.2PREMIXER ON COVER (OPTIONAL):

Open the cover and pour all of the chemical powder into the filter, close the cover and open the supply tap until all of the powder has dissolved.

4.12.2PREMIXER ON COVER (OPTIONAL):

Open the cover and pour all of the chemical powder into the filter, close the cover and open the supply tap until all of the powder has dissolved.



4.12.4COVER WASHER FOR CHEMICAL CONTAINERS

The washer for chemical containers (FIG.15) is installed as standard in the hatch on the entire Airdrop-MFC range.

To wash the container, proceed as follows:

- Lift the cover of the tank
- Open auxiliary tap (D) of the pressure regulator (see paragraph 4.8.1) supplying it with a pressure of under 8 bar
- Introduce the tin into the hopper, inserting the washing pipe into the tin.
- Press the tin onto the pipe until it has been washed clean.
- At the end of the operations close the tap (D) of the pressure regulator again.

FIG. 15



Box washing device on cover



4.13 WASHING THE ATOMISER

After every treatment, thoroughly clean the equipment, washing it with water inside and out. Dirty equipment is very dangerous for people and in particular for children.

Discharging the residues of washing in the environment without taking precautions is forbidden as this pollutes water courses. Distribute the residues on the field or the crops where they won't cause any damage. **WARNING:** the indications to follow for using chemical products are indicated in paragraph 2.2.1.

FIG. 16

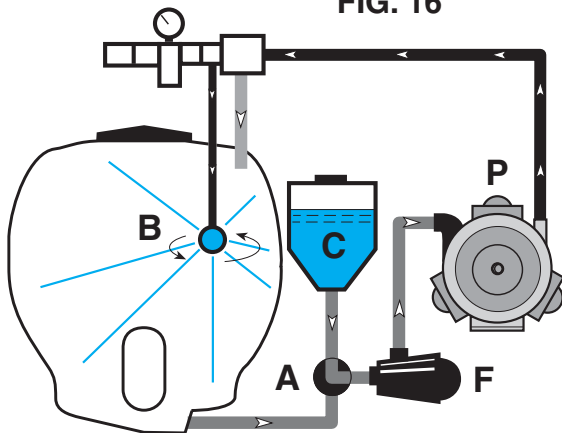

WARNING: using the taps on the pump or in any case on the front of the machine puts the operator near the cardan shaft. Despite the presence of CE standard protective covers you should take great care.



This symbol identifies the clean water tank on the machine used to wash the circuit

4.13.1 CIRCUIT WASHER AND TANK WASHER

Some machine models are fitted with a circuit washer tank (FIG.17). This tank must be filled with clean water and used to rinse the entire circuit including the suction, delivery, pump, pressure regulator, jets and nozzles. Thanks to the practical rotary nozzle it also rinses the inside surfaces of the tank.

NB: To completely clean the tank and the pipes of any residues of the various active principles, we recommend adding 2kg of soda to the washing liquid for every 100 L of water.

At the end of the treatment, wash the circuit and the tank.

- a) Stop the diaphragm pump disengaging the power-takeoff.
- b) Check you have filled the circuit washer tank (C).
- c) Make sure the main control of the pressure regulator is OFF and that all the boom sectors are closed.
- d) Turn suction deviator A to the circuit washer position (H₂O).
- e) Start the diaphragm pump by engaging the power-takeoff.
- f) Increase the engine speed until all of the liquid in circuit washer tank C has been sucked up.
- g) Turn the diaphragm pump off and turn deviator A to the work position (TANK).
- h) Turn the main control to ON, so there is pressure in the circuit.
- i) Start the diaphragm pump again and use the tank washing tap on the regulator (or on pump P) that supplies jet B.
- j) After a few minutes you can close the tank washing tap
- k) Distribute the washing residues over a portion of the field where it won't cause damage.
- l) After you have finished washing, stop the diaphragm pump.

NB: at the end of the washing cycle, if there is the risk of frost, pour roughly 500 grams of normal antifreeze for auto vehicles into the tank.

5 BLOWER GROUP

All the mistblowers have a high speed fan rotor. You must take great care and beware of the effects that this can provoke: such as the aspiration and projection of foreign bodies which, although of a small size, can be very dangerous especially for the eyes and face.



5.1 MULTIPLIER - FAN UNIT

The Airdrop range is fitted with two versions of a Ø500 centrifugal fan: STD (max absorption 30 HP) and XP (max 50 HP).

The transmission of the drive from the pump to the fan is done through a multiplier with one or two gears, plus neutral.

Normally the rotation speed of the fan is 3240 RPM in first gear and 3620 RPM in second in the 2-speed multiplier (multiplied ratios 1:6 - 1:6.7) with the power takeoff running at 540 RPM.

You can change from one gear to the next with the lever on the multiplier, made accessible through the opening on the side in the rear left part of the machine or at a distance on the right side. The lever has 2 or 3 positions depending on the number of gears and the central position is neutral (to use only the pump without the fan).



Ø500 fan with multiplier, 2-speed plus neutral.

WARNING: the gear change lever must only be used with the power-takeoff disengaged and the fan stopped. If it is difficult to engage, turn the cardan shaft slightly by hand to find the right position of the lever (make sure the tractor is turned off).

For the maintenance of the multiplier (see point "Multiplier Lubrication"



WORK TEMPERATURE



Heat is generated by the friction between the various moving components and on the basis of the power transmitted. The temperature of the multiplier or disengaging box depends on the capacity to dissipate heat to the surrounding environment and therefore the surfaces involved in the heat exchange and the environmental conditions.

The specifications refer to environmental conditions with a temperature between -10° $+50^{\circ}$ C (14° -122° F).

The working temperature limit of the box is 90° C (200° F) established to prevent the ageing of the seals and guarantee a sufficient viscosity of the oil. The heat makes the air in the box expand and therefore increases the pressure inside. The correct use of the oil seals is guaranteed up to an internal pressure of 0.5 bar. Boxes designed to be used for particularly heavy duty work are equipped with a breather cap that can be fitted on any cast iron box on request.

5.5 CLUTCH

Fans have a centrifugal type clutch that makes it possible to engage the fan rotor gradually.

This prevents jerky starts, due to the inertia of the fan rotor, which can have a negative effect on the transmission.

For the centrifugal clutch to work properly the speed of the power-takeoff mustn't be less than 450 rpm, especially if you are using the first gear of the multiplier.

Generally clutches with shoes/plates made of sintered material with a high coefficient of friction are fitted, on some low power models rubber clutches may be fitted.

WARNING! As there is a high multiplication ratio, the fan must be started gradually. Suddenly engaging the power-takeoff clutch (at high speed) can damage the gears.



Ø500 Nylon impeller with sinterized expansion clutch.

5.3 DISTRIBUTOR ACCESSORIES

Various configurations of accessories or distributors are fitted to the outlet of the fans. At present these are:

2 Fans, Canopy and Espalier - Double espalier Minibar - RV espalier and GDC - VL Espalier - FXF "Up and Over" boom for espalier.

WARNING: for all adjustments, always observe the safety indications in the chapters relevant to maintenance and repair of this manual, as well as paragraph 2.3.1 relevant to the use of chemical products.

VENTAGLI TENDONE

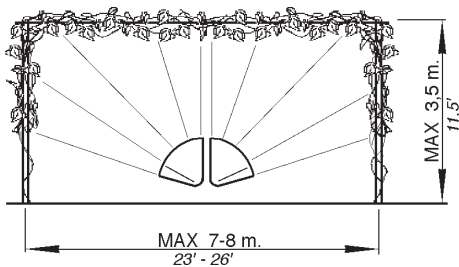

VENTAGLI SPALLIERA

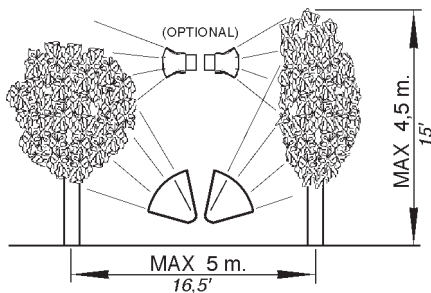

MINIBAR SPALLIERA

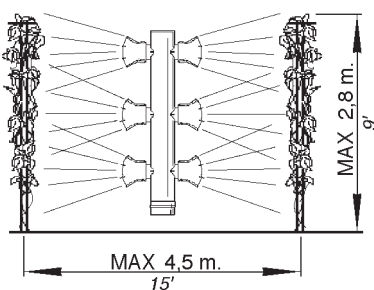

SUPER SPALLIERA

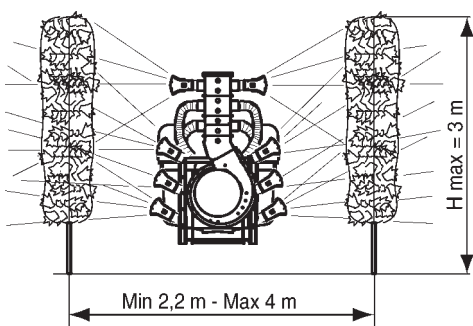

5.3.1 VENTAGLI (FANS) CANOPY, AND ESPALIER DISTRIBUTORS

These have been developed to adapt very simply to the type of vegetation to be treated.

For dosing and distribution they are equipped with two DOSER-TAPS with 1-2-3-4 calibration (see chapter 6 SPRAYING).

They turn on their own axis for the best distribution of the chemical product.

The air-outlet section is differentiated to guarantee a greater range and distribution of the mixture to where it is required.

In this way, the simple inversion of the distributors makes the system suitable for both the canopy and espalier versions; moving the left-hand distributor to the right-hand and vice-a-versa. (the same inversion must be performed for the two distributor taps 1-2-3-4).

For particularly high espaliers an upper, double distributor is available as an OPTIONAL.

The Ventagli accessories are available with STD and XP fans.

5.3.2 MINIBAR FOR ESPALIER

Tangential flow head created to bring the diffusers closer to the areas to be treated for specific and localised operations, the vertical construction positions the distributors parallel to the vegetation area, guaranteeing uniform treatment. The variable diffusers contribute to an improved distribution of the product in relation to the requirements of the vegetation.

The Minibar accessory can be used with STD fans.

5.3.2 SUPER SPALLIERA FOR ESPALIER

With this accessory you can treat particular espaliers with thick vegetation. It is especially indicated where you need to pass beyond the rows, using a lot of air and power.

The variable diffusers let you direct the product in relation to the requirements of the vegetation. All of the adjustments are done by hand using the knobs and screws.

The SUPER ESPALIER accessory is used with XP fans.

5.3.3 RV BOOM FOR GDC

This boom has lateral diffusers (variable and moveable) and two top arms with hydraulic or manual adjustment, so the jets can be directed onto the vegetation to be treated.

In the bottom part there are two adjustable, telescopic distributors for GDC treatment.

The height of the structure can be adjusted by hand for different types of vegetation.

The RV-GDC accessory is used with XP fans.

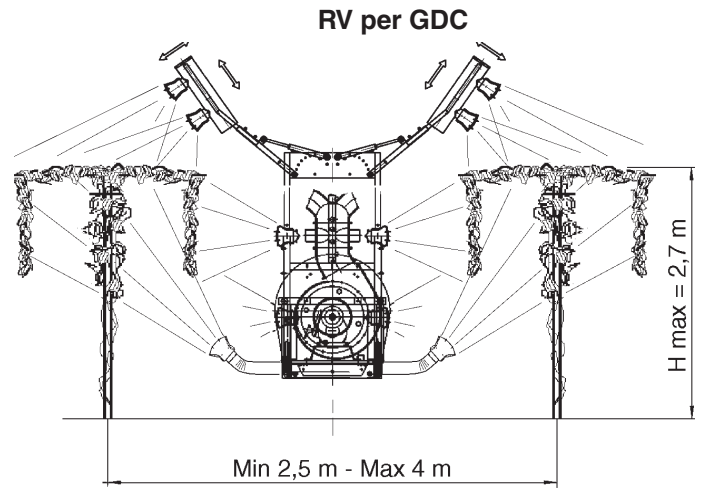

5.4 HYDRAULICS

The RV, VL, VLX, FXF and FXL model distributor accessories have hydraulics that can be controlled by the operator directly from the seat in the cab.

Check that no one and nothing is in the area where the booms will open; particular attention should be paid to the presence of any electric power lines.

The hydraulic plant can be fed from the hydraulic pump of the tractor. The hydraulics can be controlled using the lever of the tractor (RV and VL) or a hydraulic distributor with mechanical or electro-hydraulic command with switches in the cabin (VLX, FXF and FXL).

- All of the controls on both versions are sustained action controls and each lever or switch has a pictogram of the relevant operation it controls.



WARNING: with hydraulic booms, don't stand in the range of action of the machine.

Pay attention to the integrity and efficiency of the hydraulic components and in particular to the pipes to prevent the risk of bursting. Do a full check on the pipes and components at least once a year, we recommend replacing hydraulic pipes every 3-4 years.

5.4.1 OIL FEED FROM TRACTOR

(for hydraulic systems)

Connect the delivery and discharge quick-fit coupling to the respective connections, respecting the direction of flow.

The distributor inlet pipe is connected to the aluminium flow separator valve next to the distributor.

The flow separator must be adjusted correctly so it sends less than 4-5 L/1° to the distributor.

To prevent the cylinders moving at a dangerous speed, adjust the relevant chokes near the cylinders. If the registration ringnuts aren't visible then fixed chokes are fitted. The chokes are fitted on the discharge line of the movement to slow.

Any impurities in the oil could block the chokes and as a consequence block the cylinder; remove the dirt if necessary. The maximum pressure valves of the distributors are regulated to a pressure of around 150 bar.

To prevent the excessive heating of the oil we recommend supplying the distributor of the sprayer only when the cylinders are being used.

We recommend having qualified personnel do any adjustments.

Pay attention to the integrity and efficiency of the hydraulic components and in particular to the pipes to prevent the risk of bursting.

Do a full check on the pipes and components at least once a year, we recommend replacing hydraulic pipes every 3-4 years.



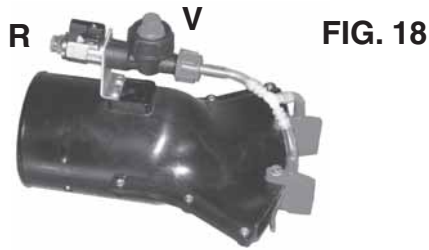

FIG. 18

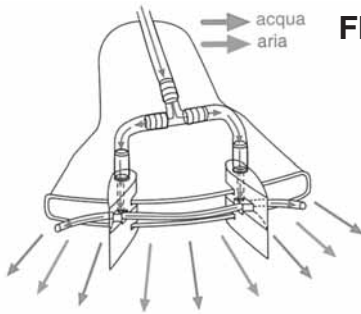

FIG. 19

6 SPRAYING

WARNING: the indications to follow when using chemical products are indicated in paragraph 2.2.1.

6.1 DESCRIPTION OF THE DIFFUSERS

The distributor accessories of the AIRDROP range are equipped with variable diffusers (FIG. 18) that let you direct the airflow (and as a consequence the treatment) on the vegetation to treat, adapting to your various needs.

According to the configuration of the accessory the diffusers have outlet mouths with different shapes and sections, furthermore they are equipped with a tap for turning the liquid on/off (R) so you can independently close one or more diffusers in the case of scarce vegetation.

In the VENTAGLI version the diffuser is the fan itself.

6.1.1 NON-DRIP VALVE

There is a non-drip valve (V) on the distributors (FIG. 18) that limits and/stops the mix dripping when the supply tap is closed. In any case we recommend closing the delivery of the mix a few seconds before disconnecting the power takeoff.

In versions with fans the valve is mounted immediately upstream of the dosing taps (see paragraph 6.4.1)

6.2 DESCRIPTION OF THE MFC® NOZZLES

The Unigreen low-volume pneumatic atomization system uses MFC® nozzles (FIG. 19) consisting of a steel wire supported by Nylon deflector vanes that also act as collectors for the liquid. The high-speed action of the air atomises the film of liquid on the wire; in this there is a high air/water surface area in contact and not just a single atomisation point, which means a big advantage in terms of uniformity and homogeneity of the jet.

VOLUME NORMALE

1 Ha = 15 hl miscela

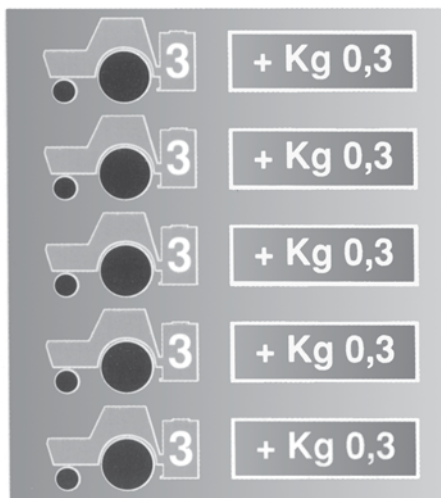

1 Ha = 15 hl = 1,5 Kg. prodotto

BASSO VOLUME

1 Ha = 3 hl miscela (5 concentrazioni)

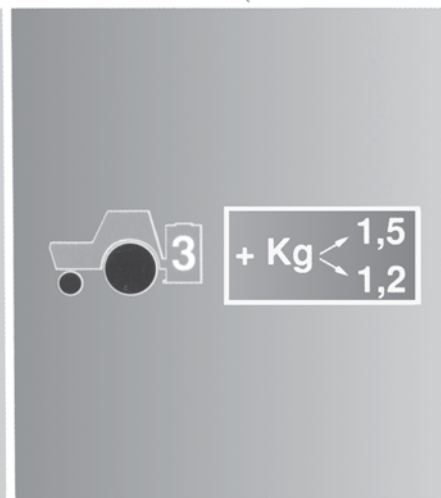

1 Ha = 3 hl = 1,5 o 1,2 Kg. prodotto

6.3 MIXTURE CONCENTRATION

As you may know, the pneumatic equipment are used for more or less concentrated treatments. To prepare the mixture, it is necessary to follow the instructions on the chemical product label. As a general rule, the product quantity to be sprayed on the hectare is the same as normal-volume treatments (a 20%-reduction is also possible); the water volume is reduced a lot even up to 9 times = 10 concentrations.

We will try to clear this concept as regards concentration with an example for the correct use both of equipment and products.

Imagine that in order to protect a normal-volume culture hectare you use 15 ml. of mixture. If the product dose recommended by the expert amounts to 100 g/hl. (normal-volume dose indicated on the label which is always to be followed), for 15 hl. You will use 1,5 kg. of products. If you decide to reduce the water quantity per hectare at 500-300-150 litres (that is to say concentrating 3-5-10 times), in these new water

volumes we must always use 1,5 kg. of product and 1,2 kg. if necessary (for reductions up to 20%). As a consequence, the mixture concentration can vary according to the water quantity that you wish to use.

From this example, you can notice a reduction of **4 fillings** and **12 ml. of water**.

5 MISTBLOWER CALIBRATION

The tables on pages 25 to 28 make it possible to determine the delivery in litres/hectares of the various equipment having the following initial data:

- position of the batching tap levers (Ventagli - Fans)
- calibrated plate CP (all others diffusers)
- used pressure;
- working speed (in km/h);
- working length (in meters).

For instance, having a mistblower with fans and knowing:

- the working length L = 4,0 meters;
 - the forward speed of 5,0 km/h;
 - the tap lever in position 2;
 - the pressure adjusted at 2,0 bars
- you will have a flow rate value of 7,0 l/min. and consequently of 210 l/ha.

Similarly, by knowing the l/ha value to be sprayed, as well as the working speed and distance, we can obtain the lever position and the pressure which is necessary for treatment.

As the speed values indicated in the tables will hardly correspond to the real ones, at first it will be necessary to calibrate the speed by operating in the following way. With the equipment in average working conditions (half-filled tank), with power take-off at 500 r.p.m. and with the fan/s in operation (without spraying), drive a measured base of 100 meters, possibly on the field on which you have to work and measure the time (t) in seconds that you need to drive it.

Then calculate speed according to the formula:

$$V = \frac{S \times 3,6}{t} \quad (1)$$

whereas **S** is the distance in meters (in our case, 100 meters) and t is the time necessary to drive it.

Example:

if **t** = 66 seconds, you will have $V = \frac{100 \times 3,6}{66} = 5,4 \text{ km/h}$

It is recommended to repeat the calibration with 2-3 different gears in order to have more data relating to speed.

As - beyond forward speed - also working width may not correspond to the ones indicated on the table, by using the flow rate in l/min. of the spraying head (see last line of table No. 3), you may obtain the volume in l/ha according to the following formula (2):

$$\text{VOLUME in l/ha.} = \frac{600 \times \text{l/min.}}{\text{working width (m)} \times \text{working speed (km/h)}} \quad (2)$$

Therefore, if from the initial example only working speed is different from **V** = 5,4 km/h, you will have:

$$\text{volume in l/ha} = \frac{600 \times 7}{4 \times 5,4} = 194 \text{ l/ha}$$

If also working width is different, for instance 3,5 m:

$$\text{volume in l/ha} = \frac{600 \times 7}{3,5 \times 5,4} = 222 \text{ l/ha}$$

6.4.1 BATCHING TAPS (SEE PICTURE 20)

On the equipment VENTAGLI (FANS) there are two batching taps which can be used to quickly change the flow rate to the jets; the long part of the lever shows the position (f.i. picture 20 = pos. 4). Each tap can carry out four different positions. In the range of each single mode, for four different pressures set on the regulator, we obtain four different values of the litre capacity per minute, for a total of 16 values as you can observe from table pages 25-26. An increase in pressure means an increase in capacity; a decrease in pressure means a decrease in capacity. For other types of heads, the number of positions and the pressure value can be different, as you can notice on the relevant tables.

6.4.2 CALIBRATED PLATES CP

In the accessories provided with an anti-dripping valve on each sprayer, on the valve output there is a calibration plate which guarantees an homogeneous distribution among the various sprayers. According to the spraying table to be carried out, it is necessary to install the plate indicated in the table.

NOTE: The plate must be mounted with the side bearing the initials towards the liquid output (picture 21).

The values indicated on the tables are approximate; according to the mixture concentration, spraying values can be slightly different. These differences can be easily corrected by acting on the working pressure. Increasing pressure means increasing spraying and vice versa.



N.B. to calculate the different ranges it is sufficient to multiply the value l/hectare by the corresponding width indicated in the table and divide it by the new width.

Example-
In the table: 907lt/ha with row distance 3m.

$$\frac{907 \times 3}{2,8} = 971 \text{ Lt/ha with row distance 2,8m}$$

FIG. 20



posiz.	Ømm	Ø inch
1	Ø1,75	Ø0,07"
2	Ø2,25	Ø0,09"
3	Ø3,50	Ø0,14"
4	Ø4,25	Ø0,17"

FIG. 21

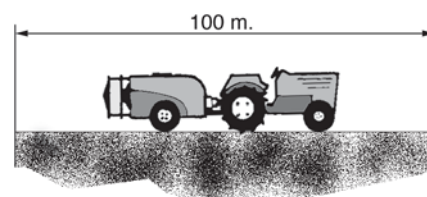
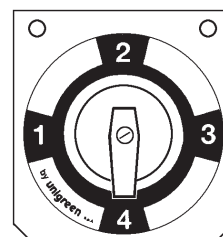
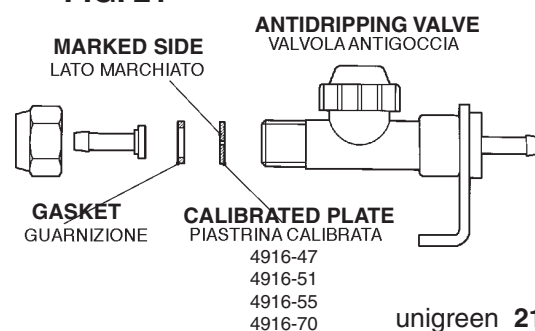
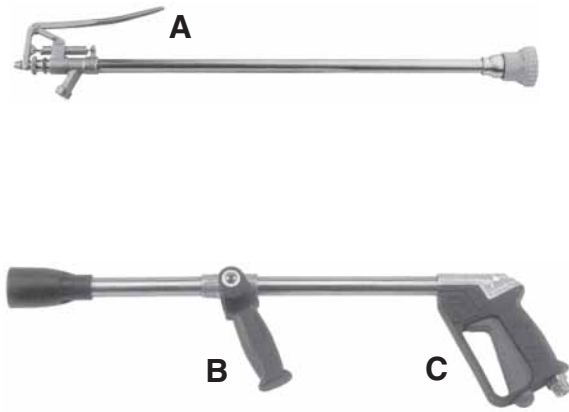

FIG. 22



7 HAND LANCES

When using hand lances bear in mind the following notes:

- = Don't direct the jet of liquid towards electric power lines or zones where there is electrical current, houses or where people might pass.
 - = Don't point the jet at people or animals.
- The jet can cause serious injuries simply due to the mechanical force of the liquid under pressure.

= Never block the spraying lever of the lance in an open position because if the lance falls it will be uncontrollable.

= At the end of work after you have stopped the pump, make sure that any residual pressure in the pipes under pressure has been drained to avoid unexpected jets when putting the lance away. There are various types of lances; with a lever, mitra spray gun and pistol grip.

For further information please refer to the handbook in the package.

The lever lance is controlled by opening lever A which, depending on how much it's pressed, produces a conical spray or direct jet. The standard nozzle is Ø 1.5. The mitra spray gun can produce a direct jet or a conical spray and the type of spray is selected by pushing lever B forwards or backwards. Use lever C to open the jet. The standard nozzle is Ø 2.5.

Replacement nozzles are available for all of the lances and the capacities are indicated in the tables TAB.4 and TAB.5 (page 29).

8 MAINTENANCE

All of the maintenance operations and repairs must be carried out with the machine and cardan shaft stopped and the tank and circuit clean of any residues of chemical products.

The maintenance of the mistblower is essential for maintaining a high level of safety. Also consult the single handbooks of the main components of the mistblower.

WARNING: the indications to follow for using chemical products are indicated in paragraph 2.2.1.



8.1 PROGRAMMED MAINTENANCE

(TAB. N° 7, page 30)

We recommend using a table of programmed maintenance to follow in time to keep the mistblower in an efficient working condition.

For major and important maintenance jobs we recommend using the normal UNIGREEN assistance service available from your reseller, (if necessary) replacing parts using original spare parts only.

8.2 ROUTINE MAINTENANCE

= After every treatment wash the inside of the tank and the entire circuit as indicated in paragraph 4.13

= Periodically check that the suction and delivery filters are clean

= Check the oil level in the volumetric compensator of the pump

= The use of chemical products that are particularly damaging for a nitrile rubber mix can cause the diaphragm to break before time.

In these conditions check the state of the components more often. There are diaphragms made of special materials (viton and desmopan) that are available on request.

= When doing treatments with copper hydroxide you should take great care to thoroughly clean the system, washing it after each treatment because hydroxides attack parts that aren't painted or protected by hot galvanising. To prevent chemical attacks we recommend spraying transparent paint on the parts that are most exposed to the product and equipping the mistblower with stainless steel pressure gauges.

8.2.1 CLEANING THE NOZZLES

Check the state of wear of the nozzles and replace them when the delivery is over 30-35% of the theoretical level.

If you notice even a partial blockage of a nozzle proceed as follows:

- drain the pressure and stop the machine
- dismantle the screw or bayonet ringnuts holding the nozzles
- clean with a small brush or compressed air, **don't use nails, punches or bradawls**
- reassemble the nozzles and the ringnuts, replacing the filters and seals.



8.2.2 LUBRICATION

The moving mechanical components must be lubricated to prevent wear and overheating. This lubrication can be done with grease or oil: oil allows

significantly higher speeds, in general grease is used to lubricate bearings with a vertical or inclined axis as it stays in the zone for longer.

8.2.3 MULTIPLIER LUBRICATION

The multiplier and disengaging boxes are normally lubricated in an “oil bath”, in special cases NLGI n.0 grease is used. The viscosity is an essential characteristic of a lubricant oil and this is indicated by the SAE (SOCIETY OF AUTO-MOTIVE ENGINEERS) classification of the oils for gearboxes and differentials. Special additives improve the capacity of the oil to maintain a lubricant film also at high pressures and temperatures. We recommended using SAE 90 oil for the multiplier and disengaging boxes. The quantity of oil is established by the level cap. A greater quantity of oil doesn't improve the conditions of lubrication and can cause overheating in the box. Changing the oil protects the parts from the dangers associated with wear and the presence of metallic particles that can be present, especially in the first period of use. We recommend replacing the oil after the first 50 working hours and then subsequently every 500 hours.

The quantity of oil needed is indicated on the sticker near the multiplier (FIG. 23)

WARNING: waste oil must not be dispersed in the environment, to dispose of waste oil see paragraph 8.7.1.



FIG. 23

8.3 EXTRAORDINARY MAINTENANCE

At the end of a season of intense use, or every two years of normal use, it is a good idea to have a specialised service technician perform a general check on the machine.

8.4 REPAIRS

We recommend having the normal UNIGREEN assistance service available from our reseller perform any repairs or contact a specialised workshop. During all of the repairs, in particular when welding, the machine and the circuit must be clean of any residues of chemical product.

If the machine has to be lifted (for example to change a wheel) follow the instructions in point 4.3 of the present handbook.

Also make sure the machine is stopped, connected to the tractor, and use the relevant chocks to block the wheel still on the ground.

If you use a jack (manual or hydraulic) make sure you use a jack that is suitable for the frame so it can't slip and put it in the right position. The jack must be placed under the main frame of the machine near the wheel to change. Make sure the ground is compact: if necessary use wooden beams or other sufficiently resistant material to broaden the supporting base of the jack.



8.5 STORAGE IN A WAREHOUSE AND TRANSPORTATION

The sprayer must be kept in a closed place away from excessive humidity and protected from frost. Especially if electrical pressure regulators, electrical motors, a spraying computer or similar components are fitted.

Before storing the machine, after you have washed it, apply a light coat of oil. If the temperature might drop to below zero, drain any residual liquid or add roughly 0.5 L of normal antifreeze for auto vehicles.

To transport the machine follow the instructions in point 4.3 of the present handbook.

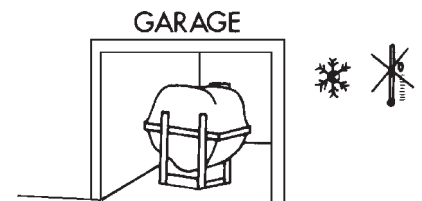

8.6 PUTTING BACK INTO SERVICE AFTER WINTER LAYUP

Before using the machine again after a long period of inactivity you should perform some general checks, following the instructions in point 4.2 and drain any antifreeze.

Never start the shaft of the pump if you think there may be ice inside. To check this, make sure you can turn the shaft by hand without connecting it to the tractor.

After you have connected the machine to the tractor (see point 4.4) following the instructions in the present user's handbook and in the enclosures of the pump, pressure regulator and accessories.





8.7 DEMOLITION AND DISPOSAL

When the sprayer will be put out of service you should wash it with great care to remove any residues of chemical product, follow the instructions in point 4.13 of the present handbook.

ATTENTION: It is necessary to adopt appropriate Individual Protection Devices in manipulating waste.

The disposal of waste deriving from the demolition of the machine must be carried out respecting the environment, avoiding soil, air and water pollution.

Local legislation in force in the matter must be respected in any case. Remember that waste is understood as any substance or object that enters into the categories shown in attachment A in part IV of Legislative Decree 152/2006, that the holder has destroyed, has decided or is obliged to destroy.

Waste deriving from the demolition of the machine is classifiable as special waste.

8.7.1 MATERIALS FOR DEMOLITION

Non-dangerous special waste is that which can be recovered, according to the February 1998 Ministerial Decree:

- Iron, aluminium, stainless steel and copper materials
- Plastic materials
- Electronic cards
- Hydraulic oil
- Electrical plant

8.7.2 INDICATIONS FOR A SUITABLE TREATMENT OF WASTE

The Correct management of special waste envisages:

- stocking in suitable places, avoiding mixing dangerous waste with the non-dangerous.
- ensuring that authorised carriers and receivers carry out its transport and disposal/recovery.

Transport of one's waste to authorised collection centres is allowed exclusively if you are enrolled in the Environmental Management Register.

8.7.3 ELECTRICAL AND ELECTRONIC APPARATUS WASTE (EEAW)

The Italian government has adopted the European Parliament directives in the matter of the disposal of electrical and electronic waste (EEAW) (2002/95/CE and 2003/108/CE Directives) with Legislative Decree n° 151, July 25 2005).

The measures: in particular, the decree established measures and procedures aimed at:

- a) forestalling the production of EEAW;
- b) promoting the re-use, recycling and other forms of EEAW recovery, in order to reduce the quantity to send for disposal;
- c) improving, in terms of the environment, the actions of the subjects who participate in the life-cycle of these apparatuses (producers, distributors, consumers and operators directly involved in the treatment of EEAW);
- d) reducing the use of dangerous substances in electrical and electronic apparatus.



The decree imposes the limitation and elimination of several substances present in EEAW: lead, mercury, cadmium, chrome, hexavalent chrome, polybrominated biphenyl, polybrominated diphenyl and polybrominated diphenyl ethers.

The machine has been designed and created in conformity with this directive. Follow the indications shown below.

The symbol to the side, showing a barred garbage can on wheels, indicates the separate collection of the electrical and electronic apparatuses of the machine.

The user of the present machine can contact the collection centres instituted by the Local Authorities or the UNIGREEN Company directly, or request withdrawal by the dealer, in order to carry out correct disposal of the waste.

AIRDROP CALIBRATING TABLES



TABLES FOR CALIBRATING AIRDROP 2 VENTAGLI (FANS)

unigreen spa		Tabella erogazione in Litri/ettaro per diffusori a ventaglio												MFC ® system			
Lt./ha spreading rate table - Fan diffusors																	
		POSIZIONE LEVE Lever Position															
		1			2			3			4			Larghezza di lavoro working width			
PRESSIONE bar		1,5	2	2,5	1,5	2	2,5	1	1,5	2	2,5	1	1,5	2	2,5		
Velocità Km/h speed	3,5	223	246	263	366	400	423	611	691	800	903	823	869	949	1063	Litri/ha	 3 m.
	4	195	215	230	320	350	370	535	605	700	790	720	760	830	930		
	5	156	172	184	256	280	296	428	484	560	632	576	608	664	744		
	6	130	143	153	213	233	247	357	403	467	527	480	507	553	620		
	7	111	123	131	183	200	211	306	346	400	451	411	434	474	531		
Velocità Km/h speed	3,5	167	184	197	274	300	317	459	519	600	677	617	651	711	797	Litri/ha	 4 m.
	4	146	161	173	240	263	278	401	454	525	593	540	570	623	698		
	5	117	129	138	192	210	222	321	363	420	474	432	456	498	558		
	6	98	108	115	160	175	185	268	303	350	395	360	380	415	465		
	7	84	92	99	137	150	159	229	259	300	339	309	326	356	399		
Velocità Km/h speed	3,5	134	147	158	219	240	254	367	415	480	542	494	521	569	638	Litri/ha	 5 m.
	4	117	129	138	192	210	222	321	363	420	474	432	456	498	558		
	5	94	103	110	154	168	178	257	290	336	379	346	365	398	446		
	6	78	86	92	128	140	148	214	242	280	316	288	304	332	372		
	7	67	74	79	110	120	127	183	207	240	271	247	261	285	319		
Litri/min.		3,9	4,3	4,6	6,4	7	7,4	10,7	12,1	14	15,8	14,4	15,2	16,6	18,6	Tab. 3215/0562F	

N.B. to calculate the different ranges it is sufficient to multiply the value lt/hectare by the corresponding width indicated in the table and divide it by the new width (see chapter 6.4, page 21).

AIRDROP CALIBRATING TABLES

TABLES FOR CALIBRATING AIRDROP 2 VENTAGLI + TOP DIFFUSORS

OPTIONAL



Tabella erogazione in Litri/ettaro per diffusori a ventaglio + diffusori superiori														MFC ® system			
unigreen spa <i>Lt./ha spreading rate table - Fan diffusers + optionals Top side diffusers</i>														CP 4916-40			
	P O S I Z I O N E L E V E L e v e r P o s i t i o n												Larghezza di lavoro working width				
	1			2			3			4							
PRESSIONE bar	1,5	2	2,5	1,5	2	2,5	1	1,5	2	2,5	1	1,5	2	2,5			
Velocità Km/h speed	3,5	359	399	436	531	584	628	816	922	1064	1204	1070	1134	1243	1396	Litri/ha	 2,5 m.
	4	314	349	382	464	511	550	714	806	931	1054	936	992	1087	1222		
	5	252	279	305	372	409	440	571	645	745	843	749	794	870	977		
	6	210	233	254	310	341	366	476	538	621	702	624	662	725	814		
	7	180	200	218	265	292	314	408	461	532	602	535	567	621	698		
Velocità Km/h speed	3,5	299	333	363	442	487	523	680	768	887	1003	891	945	1035	1163	Litri/ha	 3 m.
	4	262	291	318	387	426	458	595	672	776	878	780	827	906	1018		
	5	210	233	254	310	341	366	476	538	621	702	624	662	725	814		
	6	175	194	212	258	284	305	397	448	517	585	520	551	604	679		
	7	150	166	182	221	243	262	340	384	443	502	446	473	518	582		
Velocità Km/h speed	3,5	225	249	273	332	365	393	510	576	665	753	669	709	777	873	Litri/ha	 4 m.
	4	197	218	239	290	320	344	446	504	582	659	585	620	680	764		
	5	157	175	191	232	256	275	357	403	466	527	468	496	544	611		
	6	131	146	159	194	213	229	298	336	388	439	390	414	453	509		
	7	112	125	136	166	183	196	255	288	333	376	334	354	388	436		
Litri/min.		5,2	5,8	6,4	7,7	8,5	9,2	11,9	13,4	15,5	17,6	15,6	16,5	18,1	20,4	Litri/min. Totali	
Litri/min.		3,9	4,3	4,6	6,4	7,0	7,4	10,7	12,1	14	15,8	14,4	15,2	16,6	18,6	Solo 2 ventagli	
Litri/min.		1,34	1,52	1,76	1,34	1,52	1,76	1,2	1,34	1,52	1,76	1,2	1,34	1,52	1,76	Solo 2 diffusori	

N.B. to calculate the different ranges it is sufficient to multiply the value lt/hectare by the corresponding width indicated in the table and divide it by the new width (see chapter 6.4, page 21).

OPTIONAL

Tabella erogazione in Litri/ettaro per diffusori a ventaglio + diffusori superiori														MFC ® system			
unigreen spa <i>Lt./ha spreading rate table - Fan diffusers + optionals Top side diffusers</i>														CP 4916-47			
	P O S I Z I O N E L E V E L e v e r P o s i t i o n												Larghezza di lavoro working width				
	1			2			3			4							
PRESSIONE bar	1,5	2	2,5	1,5	2	2,5	1	1,5	2	2,5	1	1,5	2	2,5			
Velocità Km/h speed	3,5	420	462	494	591	647	686	871	982	1127	1262	1125	1195	1306	1454	Litri/ha	 2,5 m.
	4	367	404	432	517	566	600	762	859	986	1104	984	1045	1142	1272		
	5	294	324	346	414	453	480	610	687	789	883	787	836	914	1018		
	6	245	270	288	345	378	400	508	573	658	736	656	697	762	848		
	7	210	231	247	296	324	343	435	491	564	631	562	597	653	727		
Velocità Km/h speed	3,5	350	385	411	493	539	571	726	818	939	1051	937	995	1088	1211	Litri/ha	 3 m.
	4	306	337	360	431	472	500	635	716	822	920	820	871	952	1060		
	5	245	270	288	345	378	400	508	573	658	736	656	697	762	848		
	6	204	225	240	287	315	333	423	477	548	613	547	581	635	707		
	7	175	193	206	246	270	286	363	409	470	526	469	498	544	606		
Velocità Km/h speed	3,5	262	289	309	369	405	429	544	614	705	789	703	747	816	909	Litri/ha	 4 m.
	4	230	253	270	323	354	375	476	537	617	690	615	653	714	795		
	5	184	202	216	259	283	300	381	430	493	552	492	523	571	636		
	6	153	169	180	216	236	250	318	358	411	460	410	436	476	530		
	7	131	144	154	185	202	214	272	307	352	394	351	373	408	454		
Litri/min.		6,1	6,7	7,2	8,6	9,4	10,0	12,7	14,3	16,4	18,4	16,4	17,4	19,0	21,2	Litri/min. Totali	
Litri/min.		3,9	4,3	4,6	6,4	7,0	7,4	10,7	12,1	14	15,8	14,4	15,2	16,6	18,6	Solo 2 ventagli	
Litri/min.		2,2	2,4	2,6	2,2	2,4	2,6	2,0	2,2	2,4	2,6	2,0	2,2	2,4	2,6	Solo 2 diffusori	

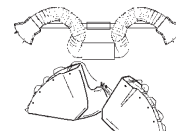
AIRDROP CALIBRATING TABLES



TABLES FOR CALIBRATING AIRDROP MINIBAR

unigreen spa Tabella erogazione in Litri/ettaro per MINIBAR spalliera (6 diffusori)																	MFC ® system				
<i>Lt./ha spreading rate table - MINIBAR</i>																					
		PIASTRINA CALIBRATA												<i>Calibrated plate</i>		Larghezza di lavoro <i>working width</i>					
		4916/40				4916/47				4916/55								4916/70			
PRESSIONE bar		1,5	2	2,5	3	1,5	2	2,5	3	1,5	2	2,5	3					1,5	2	2,5	3
Velocità Km/h <i>speed</i>	3,5	276	313	362	395	456	504	536	572	539	597	646	692	892	990	1035	1107	Litri/ha 2,5 m.			
	4	241	274	317	346	399	441	469	501	472	523	565	606	780	866	905	969				
	5	193	219	253	276	319	353	375	401	378	418	452	484	624	693	724	775				
	6	161	182	211	230	266	294	313	334	315	348	377	404	520	577	604	646				
	7	138	156	181	197	228	252	268	286	270	299	323	346	446	495	517	554				
Velocità Km/h <i>speed</i>	3,5	230	261	302	329	380	420	447	477	449	498	538	577	743	825	862	923	Litri/ha 3 m.			
	4	201	228	264	288	332	367	391	417	393	436	471	505	650	722	755	807				
	5	161	182	211	230	266	294	313	334	315	348	377	404	520	577	604	646				
	6	134	152	176	192	222	245	261	278	262	290	314	336	433	481	503	538				
	7	115	130	151	165	190	210	223	238	225	249	269	288	371	412	431	461				
Velocità Km/h <i>speed</i>	3,5	197	223	259	282	326	360	383	409	385	427	461	494	637	707	739	791	Litri/ha 3,5 m.			
	4	172	195	226	247	285	315	335	358	337	373	403	433	557	619	647	692				
	5	138	156	181	197	228	252	268	286	270	299	323	346	446	495	517	554				
	6	115	130	151	165	190	210	223	238	225	249	269	288	371	412	431	461				
	7	98	112	129	141	163	180	191	204	193	213	231	247	318	354	370	395				
Litri/min.		4,02	4,56	5,28	5,76	6,65	7,34	7,82	8,35	7,87	8,71	9,41	10,1	13	14,4	15,1	16,1	TOTALE / total			
Litri/min.		0,67	0,76	0,88	0,96	1,11	1,22	1,3	1,39	1,31	1,45	1,57	1,68	2,17	2,41	2,52	2,69	SINGOLA / single			

Tab. 3215/0578F

N.B. to calculate the different ranges it is sufficient to multiply the value lt/hectare by the corresponding width indicated in the table and divide it by the new width (see chapter 6.4, page 21).

OPTIONAL

unigreen spa Tabella erogazione in Litri/ettaro per MINIBAR spalliera (8 diffusori)																	MFC ® system				
<i>Lt./ha spreading rate table - MINIBAR (8 diffusors)</i>																					
		PIASTRINA CALIBRATA												<i>Calibrated plate</i>		Larghezza di lavoro <i>working width</i>					
		4916/40				4916/47				4916/55								4916/70			
PRESSIONE bar		1,5	2	2,5	3	1,5	2	2,5	3	1,5	2	2,5	3					1,5	2	2,5	3
Velocità Km/h <i>speed</i>	3,5	368	417	483	527	608	671	715	763	719	797	861	923	1189	1320	1380	1476	Litri/ha 2,5 m.			
	4	322	365	422	461	532	588	625	668	629	697	753	807	1040	1155	1207	1292				
	5	257	292	338	369	425	470	500	534	503	558	602	646	832	924	966	1033				
	6	214	243	282	307	355	392	417	445	420	465	502	538	693	770	805	861				
	7	184	208	241	263	304	336	357	382	360	398	430	461	594	660	690	738				
Velocità Km/h <i>speed</i>	3,5	306	347	402	439	507	560	596	636	599	664	717	769	991	1100	1150	1230	Litri/ha 3 m.			
	4	268	304	352	384	443	490	521	556	524	581	628	673	867	962	1006	1076				
	5	214	243	282	307	355	392	417	445	420	465	502	538	693	770	805	861				
	6	179	203	235	256	295	326	347	371	350	387	418	449	578	642	671	718				
	7	153	174	201	219	253	280	298	318	300	332	359	384	495	550	575	615				
Velocità Km/h <i>speed</i>	3,5	263	298	345	376	434	480	511	545	514	569	615	659	849	943	985	1054	Litri/ha 3,5 m.			
	4	230	261	302	329	380	420	447	477	449	498	538	577	743	825	862	923				
	5	184	208	241	263	304	336	357	382	360	398	430	461	594	660	690	738				
	6	153	174	201	219	253	280	298	318	300	332	359	384	495	550	575	615				
	7	131	149	172	188	217	240	255	273	257	284	307	330	425	471	493	527				
Litri/min.		5,36	6,08	7,04	7,68	8,86	9,79	10,4	11,1	10,5	11,6	12,6	13,5	17,3	19,2	20,1	21,5	TOTALE / total			
Litri/min.		0,67	0,76	0,88	0,96	1,11	1,22	1,3	1,39	1,31	1,45	1,57	1,68	2,17	2,41	2,52	2,69	SINGOLA / single			

Tab. 3215/0578F

AIRDROP CALIBRATING TABLES



TABLES FOR CALIBRATING AIRDROP SUPER SPALLIERA

unigreen spa Tabella erogazione in Litri/ettaro per SUPER SPALLIERA (8 diffusori)																	MFC ® system		
<i>Lt./ha spreading rate table - SUPER SPALLIERA (8 diffusors)</i>																			
		PIASTRINA CALIBRATA												Larghezza di lavoro <i>working width</i>					
		4916/40				4916/47				4916/55						4916/70			
PRESSIONE bar		1,5	2	2,5	3	1,5	2	2,5	3	1,5	2	2,5	3			1,5	2	2,5	3
Velocità Km/h <i>speed</i>	3,5	368	417	483	527	608	671	715	763	719	797	861	923	1189	1320	1380	1476	Litri/ha 	
	4	322	365	422	461	532	588	625	668	629	697	753	807	1040	1155	1207	1292		
	5	257	292	338	369	425	470	500	534	503	558	602	646	832	924	966	1033		
	6	214	243	282	307	355	392	417	445	420	465	502	538	693	770	805	861		
	7	184	208	241	263	304	336	357	382	360	398	430	461	594	660	690	738		
Velocità Km/h <i>speed</i>	3,5	306	347	402	439	507	560	596	636	599	664	717	769	991	1100	1150	1230	Litri/ha 	
	4	268	304	352	384	443	490	521	556	524	581	628	673	867	962	1006	1076		
	5	214	243	282	307	355	392	417	445	420	465	502	538	693	770	805	861		
	6	179	203	235	256	295	326	347	371	350	387	418	449	578	642	671	718		
	7	153	174	201	219	253	280	298	318	300	332	359	384	495	550	575	615		
Velocità Km/h <i>speed</i>	3,5	230	261	302	329	380	420	447	477	449	498	538	577	743	825	862	923	Litri/ha 	
	4	201	228	264	288	332	367	391	417	393	436	471	505	650	722	755	807		
	5	161	182	211	230	266	294	313	334	315	348	377	404	520	577	604	646		
	6	134	152	176	192	222	245	261	278	262	290	314	336	433	481	503	538		
	7	115	130	151	165	190	210	223	238	225	249	269	288	371	412	431	461		
Litri/min.		5,36	6,08	7,04	7,68	8,86	9,79	10,4	11,1	10,5	11,6	12,6	13,5	17,3	19,2	20,1	21,5	TOTALE / total	
Litri/min.		0,67	0,76	0,88	0,96	1,11	1,22	1,3	1,39	1,31	1,45	1,57	1,68	2,17	2,41	2,52	2,69	SINGOLA / single	

Tab. 3215/000F

N.B. to calculate the different ranges it is sufficient to multiply the value lt/hectare by the corresponding width indicated in the table and divide it by the new width (see chapter 6.4, page 21).

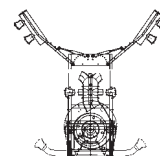

TABLES FOR CALIBRATING AIRDROP RV-GDC

unigreen spa Tabella erogazione in Litri/ettaro per RV GDC (10 diffusori)																	MFC ® system		
<i>Lt./ha spreading rate table RV -GDC (10 diffusors)</i>																			
		PIASTRINA CALIBRATA												Larghezza di lavoro <i>working width</i>					
		4916/34				4916/40				4916/47						4916/51			
PRESSIONE bar		1,5	2	2,5	3	1,5	2	2,5	3	1,5	2	2,5	3			1,5	2	2,5	3
Velocità Km/h <i>speed</i>	3,5	309	357	398	439	459	521	603	658	760	839	893	954	818	900	976	1041	Litri/ha 	
	4	270	312	348	384	402	456	528	576	665	734	782	835	716	788	854	911		
	5	216	250	278	307	322	365	422	461	532	588	625	668	573	630	684	729		
	6	180	208	232	256	268	304	352	384	443	490	521	556	477	525	570	607		
	7	154	178	199	219	230	261	302	329	380	420	447	477	409	450	488	520		
Velocità Km/h <i>speed</i>	3,5	257	297	331	366	383	434	503	549	633	699	745	795	682	750	814	867	Litri/ha 	
	4	225	260	290	320	335	380	440	480	554	612	652	696	597	657	712	759		
	5	180	208	232	256	268	304	352	384	443	490	521	556	477	525	570	607		
	6	150	173	193	213	223	253	293	320	369	408	434	464	398	438	475	506		
	7	129	149	166	183	191	217	251	274	317	350	372	397	341	375	407	434		
Velocità Km/h <i>speed</i>	3,5	193	223	249	274	287	326	377	411	475	525	558	596	511	563	610	651	Litri/ha 	
	4	169	195	218	240	251	285	330	360	416	459	489	522	447	492	534	569		
	5	135	156	174	192	201	228	264	288	332	367	391	417	358	394	427	455		
	6	113	130	145	160	168	190	220	240	277	306	326	348	298	328	356	380		
	7	96	111	124	137	144	163	189	206	237	262	279	298	256	281	305	325		
Litri/min.		4,5	5,2	5,8	6,4	6,7	7,6	8,8	9,6	11,1	12,2	13	13,9	11,9	13,1	14,2	15,2	TOTALE / total	
Litri/min.		0,45	0,52	0,58	0,64	0,67	0,76	0,88	0,96	1,11	1,22	1,3	1,39	1,19	1,31	1,42	1,52	SINGOLA / single	

Tab. 3215/0000

TABLE 4-5 TABLES OF DELIVERY OF NOZZLES FOR HAND LANCES

TABLE OF DELIVERY IN LITRES / MIN. OF THE CONICAL NOZZLES FOR LEVER LANCE									
note: standard Ø1,5 nozzle									
DIAMETER NOZZLE			Ø 1,0	Ø 1,2	Ø 1,5	Ø 1,75	Ø 2,0	Ø 2,2	Ø 2,5
PRESSURE (BAR)	JET	CAPACITY (Lt / min)							
			5	cone	1,16	1,40	1,90	2,25	2,65
		direct jet	1,40	1,70	2,50	3,95	4,7	6,00	7,70
	8	cone	1,40	1,80	2,60	2,80	3,40	3,65	4,45
		direct jet	1,70	2,20	3,40	4,85	6,00	7,60	9,80
	10	cone	1,50	1,96	2,90	3,10	3,90	4,10	5,00
		direct jet	1,90	2,40	3,75	5,40	6,95	8,55	11,0
	15	cone	1,88	2,40	3,40	3,80	4,50	5,00	6,10
		direct jet	2,30	3,00	4,50	6,65	8,30	10,4	13,4
	30	cone	2,60	3,40	4,80	5,40	6,30	7,10	8,70
		direct jet	3,20	4,20	6,40	9,40	11,7	14,7	19,1
TABLE. 4	50	cone	3,40	4,40	6,20	6,80	8,10	9,20	11,2
		direct jet	4,10	5,40	8,30	11,8	15,1	19,1	24,6

TABLE OF DELIVERY IN LITRES / MIN. OF THE CONICAL NOZZLES FOR MITRA SPRAY GUN										
note: standard Ø2,5 nozzle										
DIAMETER NOZZLE			Ø 1,0	Ø 1,2	Ø 1,5	Ø 1,8	Ø 2,0	Ø 2,3	Ø 2,5	Ø 3,0
PRESSURE (BAR)	JET	CAPACITY (Lt / min)								
			15	cone	2,45	3,60	4,60	5,90	6,90	8,10
		direct jet	2,50	3,80	5,10	7,30	8,80	10,8	13,0	18,4
	25	cone	3,00	4,25	5,70	7,20	8,10	10,2	11,4	14,4
		direct jet	3,10	4,60	6,50	9,30	11,7	14,1	16,4	24,1
	35	cone	3,40	4,70	6,60	8,50	10,2	12,9	14,0	18,0
		direct jet	3,50	5,40	7,40	10,8	13,4	16,8	19,1	28,2
	40	cone	3,55	5,20	6,90	9,20	10,9	13,7	14,5	18,8
		direct jet	3,65	5,90	7,80	11,7	14,3	17,9	21,0	30,1
TABLE. 5	50	cone	4,00	5,60	7,70	10,5	12,5	14,9	16,4	20,9
		direct jet	4,10	6,30	8,60	12,7	15,8	19,7	23,0	33,0

TABLE 7 TABLE OF PROGRAMMED MAINTENANCE

OPERATION	8 h	50 h	300 h	END OF SEASON
Check the level and state of the oil	0			
Check the accumulator pressure		0		
Check the suction (hoses, pipes, unions)		0		
Check and clean the suction and delivery filters	0			
Check the pump fixing feet and screws in general		0		
Check the diaphragm and the oil and change if necessary			X (1)	X (2)
Check the suction/delivery valves			X	X
Check the pump screws and bolts are tight				X
Check and clean the nozzles and the non-drip diaphragm	0			
Check the wear of the nozzles			0	
Check the hydraulic oil level		0		
Check any failures or cracking of the welds, especially on herbicide booms				0
Grease the articulated joints and the wheel hubs		0		
Check the tyre pressure		0		

NOTE: 0 Operation to be carried out by the operator
 X Operation to be carried out by a specialised technician or in an authorised workshop
 (1) First oil change
 (2) Change at the same time a changing the diaphragm

TABLE 8 PROBLEMS, CAUSES AND SOLUTIONS

PROBLEMS	CAUSES	SOLUTIONS
The pump won't charge	Air suction	Check the suction system
	Adjustment valve closed (Command group isn't at zero pressure)	Position the lever correctly
	Valves and/or valve seats suction and delivery worn or dirty	Replace or clean (*)
The pump doesn't reach the set pressure	Valve and/or valve seat adjustment worn	Replace (*)
	Valves and/or valve seats suction and delivery worn or dirty	Replace or clean (*)
	Insufficient rpm	Bring speed up to correct rpm always in the field of 350 ÷ 550 rpm.
	The nozzles used are worn or have holes that are too big	Replace
Irregular pressure (with impulses)	Suction blocked	Clean the cartridge of the filter or remove the blockage
	Valves and/or valve seats suction and delivery worn or dirty	Replace or clean (*)
Excessive vibrations at delivery	Air suction	Check the suction system
	Pressure accumulator discharged or incorrect air pressure	Bring the air pressure back up to the right value (see pump handbook) (*)
Noisiness and the level of the oil has dropped	Blocked suction	Check the suction system
Water in the oil	Breakage of one or more diaphragms	Replace (*) If the replacement isn't done immediately, drain the water out of the pump and introduce clean oil without water (also used) or diesel to stop rust attacking the internal parts
No liquid comes out of the nozzles	Delivery filter dirty Non-drip filters dirty Nozzles blocked	Clean

NOTE: (*) Only specialised technician

TAB.18A ALLOWED FITTINGS

2005		MOUNTED ATOMISERS Polyethylene Tank									
TYPE OF MACHINE		AIRDROP - MFC									
FITTING	Nominal capacity (L.)	P200		P300		P400		P500		P600	
		200	200	300	300	400	400	500	500	600	600
FAN GROUP	STD Ø500	X		X		X		X		X	
	XP Ø500		X		X		X		X		X
PUMPS COMET	" " APS 51	X	X	X	X	X	X	X	X	X	X
	" " APS 71				X		X		X		X
	" " APS 96										
PRESSURE REGULATOR	GCP 2 ELECTRIC	X	X	X	X	X	X	X	X	X	X
	GCP 2 ELECTRIC +PRES	X	X	X	X	X	X	X	X	X	X
NOZZLES	MFC	X	X	X	X	X	X	X	X	X	X
DISTRIBUTOR ACCESSORIES	2 VENTAGLI	X	X	X	X	X	X	X	X	X	X
	MINIBAR	X		X		X		X		X	
	SUPER SPALLIERA		X		X		X		X		X
	RV						X		X		X
	RV GDC						X		X		X
OPTIONAL	TOP DISTR for VENTAGLI		X		X		X		X		X
	MIXER LP83	X	X	X	X	X	X	X	X	X	X
	COMPUTER					X	X	X	X	X	X
TOTAL MASS in Kg	EMPTY MAX FITINGS	270	270	280	280	370	450	380	460	390	470
	FULL MAX FITINGS	530	530	640	640	920	1000	1030	1110	1140	1220
P HP	POWER NECESSARY	27	59	27	59	27	59	27	59	27	59

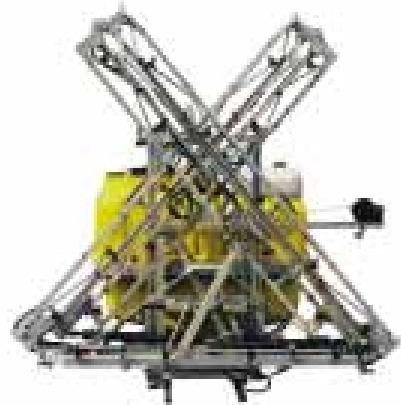

unigreen[®]
S.p.A.
CROP PROTECTION

via Rinaldi, 105 - Loc. Cavazzoli (Reggio Emilia) - ITALY

Tel. +39 0522 369811

Fax. +39 0522 369898

e-mail: info@unigreen-spa.com
internet: www.unigreen-spa.com

member of the **YAMAHA** group



UNACOMA MEMBER

Descriptions, indicative illustrations, UNIGREEN S.P.A. reserves the right to make variations or modifications without prior warning.

Free Manuals Download Website

<http://myh66.com>

<http://usermanuals.us>

<http://www.somanuals.com>

<http://www.4manuals.cc>

<http://www.manual-lib.com>

<http://www.404manual.com>

<http://www.luxmanual.com>

<http://aubethermostatmanual.com>

Golf course search by state

<http://golfingnear.com>

Email search by domain

<http://emailbydomain.com>

Auto manuals search

<http://auto.somanuals.com>

TV manuals search

<http://tv.somanuals.com>