

## **TECHNICAL ASSISTANCE**

When trouble is reported, verify there are no broken connections to the unit. Assistance in troubleshooting is available from the factory. When calling, you should have a Volt-ohm meter and a lineman's test set available and be calling from the job site. Call (540) 427-3900 and ask for Technical Support, or call (540) 427-6000 for Valcom 24-hour Automated Support or visit our website at <http://www.valcom.com>.

Valcom equipment is not field repairable. Valcom, Inc. maintains service facilities in Roanoke, VA. Should repairs be necessary, attach a tag to the unit clearly stating your company name, address, phone number, contact person, and the nature of the problem. Send the unit to:

**Valcom, Inc.  
Repair and Return Dept.  
5614 Hollins Road  
Roanoke, VA 24019-5056**

### **VALCOM LIMITED WARRANTY**

Valcom, Inc. warrants its products to be free from defects in materials and workmanship under conditions of normal use and service for a period of one year from the date of shipment. The obligation under this warranty shall be limited to the replacement, repair or refund of any such defective device within the warranty period, provided that:

1. inspection by Valcom, Inc. indicates the validity of the claim,
2. the defect is not the result of damage, misuse, or negligence after the original shipment.
3. the product has not been altered in any way or repaired by others and that factory sealed units are unopened (A service charge plus parts and labor will be applied to units defaced or physically damaged),
4. freight charges for the return of products to Valcom are prepaid,
5. all units 'out of warranty' are subject to a service charge. The service charge will cover minor repairs (Major repairs will be subject to additional charges for parts and labor).

**This warranty is in lieu of and excludes all other warranties, expressed or implied, and in no event shall Valcom, Inc. be liable for any anticipated profits, consequential damages, loss of time or other losses incurred by the buyer in connection with the purchase, operation, or use of the product.**

This warranty specifically excludes damage incurred in shipment. In the event a product is received in damaged condition, the carrier should be notified immediately. Claims for such damage should be filed with the carrier involved in accordance with the F.O.B. point.

Headquarters:  
Valcom, Inc.  
1111 Industry Avenue  
Roanoke, VA 24013  
Phone: (540) 427-3900  
FAX: (540) 427-3517

In Canada  
CMX Corporation  
35 Van Kirk Drive #11 and 12  
Brampton, Ontario L7A1A5  
Phone: (905) 456-1072  
FAX: (905) 456-2269

## **INSTALLATION INSTRUCTIONS FOR**

# **VALCOM**

## **SIGNATURE SERIES™, HIGH FIDELITY**

## **AMPLIFIED CEILING SPEAKER**



### **MODEL NO. V-1420**

**Issue 4**

**947146**

## VALCOM SIGNATURE SERIES™, HIGH FIDELITY CEILING SPEAKER

Valcom Signature Series™ Ceiling Speaker, V-1420, is a high fidelity, self-amplified (6 watt amplifier) speaker and may be used to provide one-way paging and high quality music reproduction from any Valcom page control. This speaker has an adjustable volume control located on the front of the unit. The V-1420 required -24VDC, 200mA (4 Valcom power units). The speaker is available in a white powder epoxy finish.

**NOTE:** No power amplifier required. Do not connect this speaker directly to a 25/70/100 volt amplifier as damage to both the amplifier and speaker may occur. (Recommended nominal input level to the V-1420 is -10dBm).

### MOUNTING CONNECTIONS

Cut an 8.5" diameter hole in ceiling tile. After connections have been made to the speaker, attach speaker to ceiling tile using the mounting hardware provided. (A metal backbox with rails is available separately as model V-9816M).

### Typical Connections to a Valcom Page Adapter

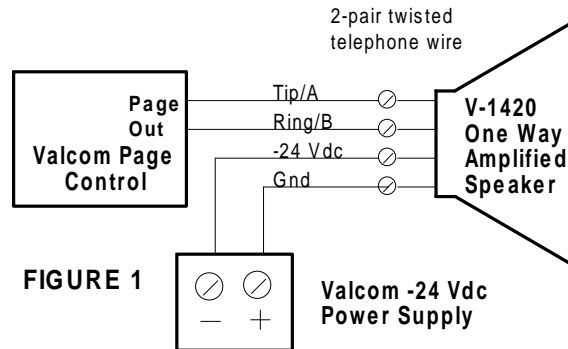
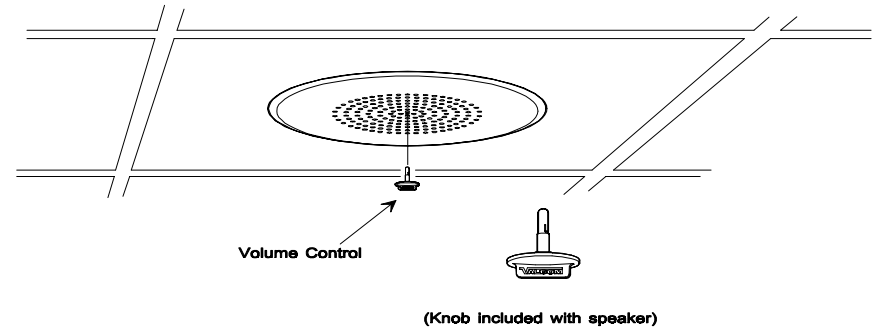

FIGURE 1

### **Recommended Quantity of Speakers per Specific Power Run** (Standard Category 3 Twisted Pair Telephone Wire)

SPEAKERS PER POWER RUN	WIRE RUN LENGTH (FT.)	
	24-AWG	22AWG
V-1420		
4	300	500
2	500	800
1	775	1200



### **FCC NOTICE**

**NOTE:** The equipment has been tested and found to comply with the limits for Class A digital devices, pursuant to Part 15 of the FCC Rules. These limits are designed to provide reasonable protection against harmful interference when the equipment is operated in a commercial environment. This equipment generates, uses, and can radiate radio frequency energy and, if not installed and used in accordance with the instruction manual, may cause harmful interference to radio communications. Operation of this equipment in a residential area is likely to cause harmful interference in which case the user will be required to correct the interference at his own expense.

**NOTE:** This unit was tested with shielded cables and peripheral devices. Shielded cables must be used with the unit to insure compliance.

**NOTE:** The manufacturer is not responsible for any radio or TV interference caused by unauthorized modifications to this equipment. Such modifications could void the user's authority to operate the equipment.

### **TROUBLESHOOTING CHART**

SYMPTOM	ACTION
No audio from speaker	<ol style="list-style-type: none"> <li>1. Verify volume control is turned up (clockwise).</li> <li>2. Using a lineman's test set, check for proper audio level on Tip/A and Ring/B leads and if necessary at the source.</li> </ol>
Low volume from speaker	<ol style="list-style-type: none"> <li>1. Verify volume control is turned up.</li> <li>2. Check voltage at the speaker when in use, (-18 to -24VDC required).</li> <li>3. Using a lineman's test set, check for proper audio level on Tip/A and Ring/B leads. It is possible some low level audio will be heard with only one side of Tip/A and Ring/B connected.</li> </ol>
Loud squeal (feedback).	<ol style="list-style-type: none"> <li>1. Decrease volume of speaker (counterclockwise).</li> <li>2. Increase the distance between telephone and speaker.</li> <li>3. Install confidencer on the telephone in severe problem areas.</li> </ol>

### **Dimensions/Weight**

- 13.0"Dia. x 3.0"D (33cm Dia. x 7.6cm D)
- 3.5 lbs. (1.59 kg)

## Free Manuals Download Website

<http://myh66.com>

<http://usermanuals.us>

<http://www.somanuals.com>

<http://www.4manuals.cc>

<http://www.manual-lib.com>

<http://www.404manual.com>

<http://www.luxmanual.com>

<http://aubethermostatmanual.com>

Golf course search by state

<http://golfingnear.com>

Email search by domain

<http://emailbydomain.com>

Auto manuals search

<http://auto.somanuals.com>

TV manuals search

<http://tv.somanuals.com>