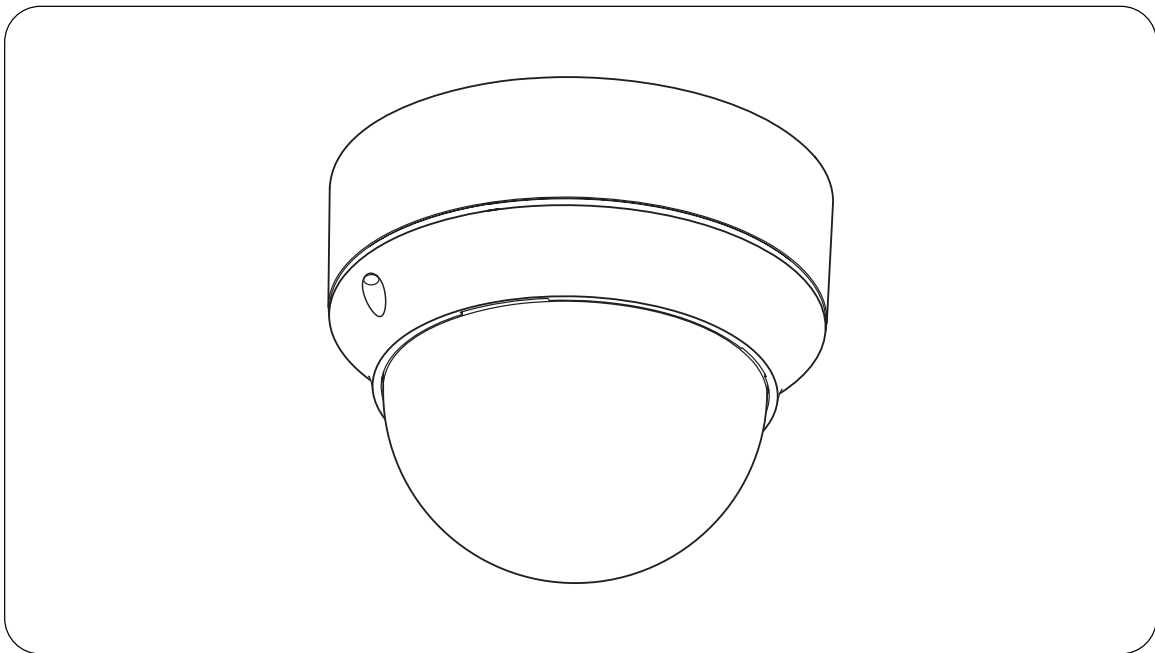

COLOR DOME CAMERA
**C-CV24-3 CU
C-CV24-2 NTSC**

TABLE OF CONTENTS

1. SAFETY PRECAUTIONS	2	8. ABOUT THE MODE SETTING SWITCH	
2. GENERAL DESCRIPTION	3	8.1. Adjustment Switch	10
3. HANDLING PRECAUTIONS	3	8.2. Backlight Compensation Switch	10
4. NOMENCLATURE	4	8.3. Shutter Speed Switch	10
5. INSTALLATION		9. IF YOU THINK THERE IS A FAILURE:	
5.1. Installation	5	(TROUBLESHOOTING)	11
6. CONNECTIONS	8	10. SPECIFICATIONS	12
7. ADJUSTMENT	9		

Thank you for purchasing TOA's Color Dome Camera. Please carefully follow the instructions in this manual in order to ensure long, trouble-free use of your color camera.

TOA Corporation

1. SAFETY PRECAUTIONS

- Before installation or use, be sure to carefully read all the instructions in this section in order to ensure long, trouble-free operation.
- Be sure to follow all the precautionary instructions in this section, which contain important warnings regarding safety.
- After reading, keep this manual handy for future reference.

Safety Symbol and Message Conventions

Safety symbols and messages are used in this manual to prevent bodily injury and property damage which could result from mishandling. Before doing anything else, read this section first so you are thoroughly aware of the potential safety hazards as well as understanding the safety symbols and messages.



WARNING

Do not expose the unit to rain or an environment where it may be splashed by water or other liquids, as doing otherwise may result in fire or electric shock.



WARNING

Indicates a potentially hazardous situation which could result in death or serious personal injury if ignored or mishandled.

- Use the unit only with the voltage specified on the unit. Using a voltage other than that which is specified may result in fire or electric shock.
- Avoid installing or mounting the unit in unstable locations, such as on a rickety table or a slanted surface. Failure to do so may result in the unit falling down and causing personal injury.
- Install the unit only in a location that can structurally support the weight of the unit and the mounting bracket. Doing otherwise may result in the unit falling and causing personal injury.
- Do not install the unit outdoors since it is designed for indoor use. If installed outdoors, the aging of parts causes the unit to fall down, possibly resulting in personal injury. Also, when it is exposed to rain, an electric shock may result.
- Should any of the following irregularities be found during use, immediately switch off the power, disconnect the power supply cord from the AC outlet and contact your TOA dealer. Do not attempt to further use the unit because a fire or electric shock may result.
 - If you detect smoke or a strange smell coming from the unit.
 - If water or a foreign object enters the unit.
 - If the unit falls or the unit case breaks.
 - If the power supply cord is damaged (exposure of core or disconnection).
 - If no image is displayed on the screen.
- Do not open nor modify the unit's case to prevent a fire or electric shock because there are high voltage components inside the unit. Refer all inspection, adjustment and repair work to the dealer from where the unit was purchased.
- Do not insert or drop metal pieces or flammable materials into the unit's ventilation slots as this may result in fire or electric shock.
- Have the unit periodically checked by the dealer from where it was purchased. Should the unit or its mounts corrode or structurally deteriorate, the unit could fall down, possibly resulting in personal injury.



CAUTION

Indicates a potentially hazardous situation which could result in moderate or minor personal injury, and/or property damage if ignored or mishandled.

- Avoid installing the unit in humid or dusty locations, in locations exposed to the direct sunlight, near the heaters, or in locations generating sooty smoke or steam as doing otherwise may result in fire or electric shock.
- Leave the unit's installation to the dealer from where the unit was purchased because the installation requires expert knowledge. Inadequate installation may cause the unit to fall, possibly resulting in personal injury.
- Do not hang from the unit, as the unit may fall, possibly resulting in personal injury.
- When the unit is cleaned or is not used for a long period of time, remove the power supply plug from the AC outlet in order to avoid electric shock or fire.

Note

This equipment has been tested and found to comply with the limits for a Class B digital device, pursuant to Part 15 of the FCC Rules. These limits are designed to provide reasonable protection against harmful interference in a residential installation. This equipment generates, uses and can radiate radio frequency energy and, if not installed and used in accordance with the instructions, may cause harmful interference to radio communications. However, there is no guarantee that interference will not occur in a particular installation. If this equipment does cause harmful interference to radio or television reception, which can be determined by turning the equipment off and on, the user is encouraged to try to correct the interference by one or more of the following measures:

- Reorient or relocate the receiving antenna.
- Increase the separation between the equipment and receiver.
- Connect the equipment into an outlet on a circuit different from that to which the receiver is connected.
- Consult the dealer or an experienced radio/ TV technician for help.

Modifications

Any modifications made to this device that are not approved by TOA Corporation may void the authority granted to the user by the FCC to operate this equipment.

Underwriters Laboratories Inc. (UL) has not tested the performance or reliability of the security aspects of this product. UL has only tested for fire, shock or casualties as outlined in UL's Standard(s) for Safety. UL Certification does not cover the performance or reliability of the security hardware and security operating software. UL MAKES NO REPRESENTATIONS, WARRANTIES OR CERTIFICATIONS WHATSOEVER REGARDING THE PERFORMANCE OR RELIABILITY OF ANY SECURITY RELATED FUNCTIONS OF THIS PRODUCT.

2. GENERAL DESCRIPTION

The C-CV24-2 and C-CV24-3 Color Dome Camera is an indoor-use camera and is equipped with a high-resolution camera and lens. It is designed to operate on 24 V AC or 12 V DC, which are supplied by an external power supply unit. Since its vari-focal, auto-iris lens is built inside the camera, its angle of view can be manually adjusted.

3. HANDLING PRECAUTIONS

- Do not direct the camera lens to the sun or strong lighting or light reflection. Exposure to direct sunlight could cause the CCD's color filter to deteriorate, leading to image discoloration.
- Avoid jarring or striking the camera, as the camera may fail.
- Install the camera in locations where the temperature range does not exceed -10°C to $+50^{\circ}\text{C}$, and no dew condensation is formed.
- To clean, wipe with a soft, dry cloth. Never use benzene, thinner or chemically-treated towel to avoid damage to the camera's finish.
- To clean the lens, use a camera blower or lightly wipe with lens cleaning paper.
- Picture quality may suffer if camera cables are wired close to other electrical equipment, such as fluorescent lamps. In such cases, reroute the wiring.
- Monitor screen pictures may become distorted or roll if the camera is used in locations influenced by strong electrical or magnetic fields from television transmission antennas, motors or transformers. In such cases, install the cables inside sheet steel cable conduit.
- Do not install the camera in locations where solvents or chemicals are used, as exposure to such chemicals could damage the dome cover finish.
- Use the external power supply unit of the following rating when the camera is operated on 12 V DC.
12 V DC, over 1.0 A

4. NOMENCLATURE

[Bottom view]

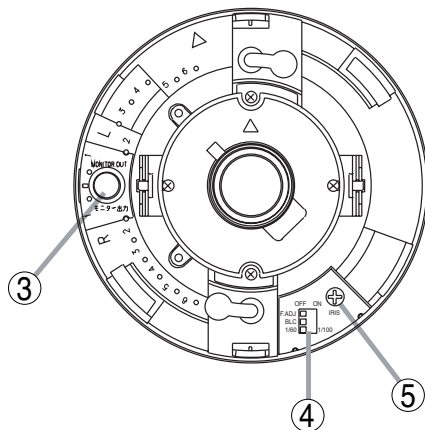

[Top view]

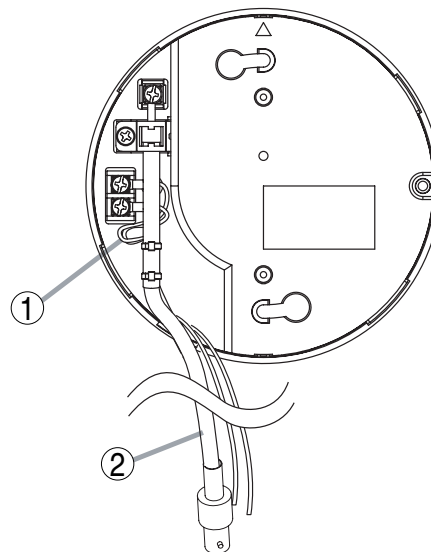

[Side view]

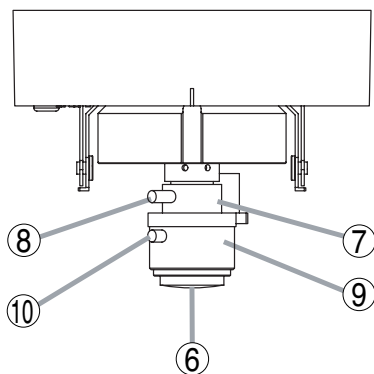

[Side view of the camera with a dome cover]

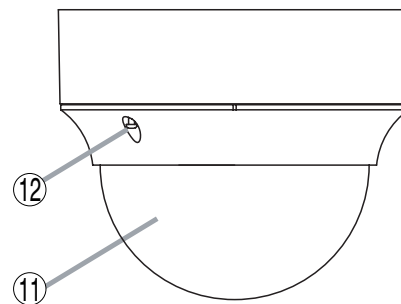

(1) Power input cable
(24 V AC or 12 V DC)

(2) Video output cable

(3) Monitor output terminal
(RCA pin jack)

(4) Mode setting switch

(5) Iris control

(6) Vari-focal lens

(7) Zoom ring

(8) Zoom ring fixing screw

(9) Focus ring

(10) Focus ring fixing screw

(11) Dome cover

(12) Dome cover turn stop screw

5. INSTALLATION

5.1. Installation

1. Determine the installation method.

1-1. Unexposed wiring

Using the installation hole gauge, make a cable entry hole in the ceiling.

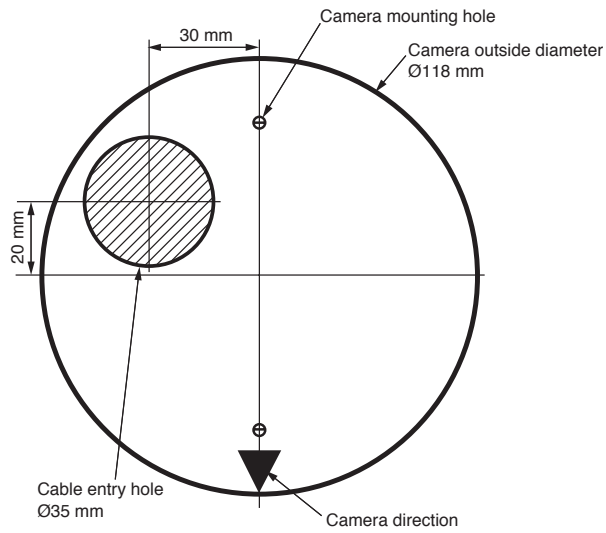

1-2. Open wiring

Cut out the thin camera section shown below using a pair of nippers.

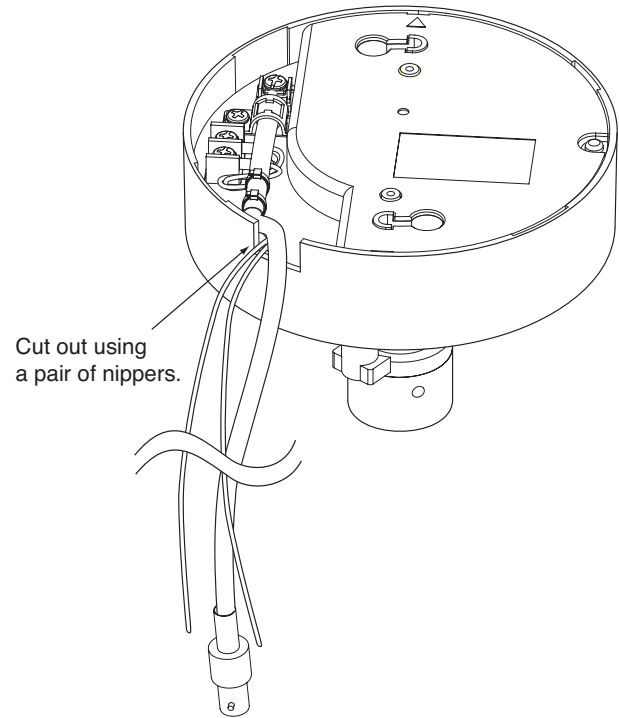

2. Mount the camera to the ceiling or wall using 2 mounting screws.

Because the mounting screws are not supplied with the camera, prepare appropriate screws for the application. (Use screws that are over 4 mm in nominal diameter and longer than 25 mm.)

Ceiling mounting : Orient the \triangle mark located on the camera's bottom surface toward the direction in which the camera is to be pointed.

Wall mounting : Orient the \triangle mark located on the camera's bottom surface up (toward the ceiling).

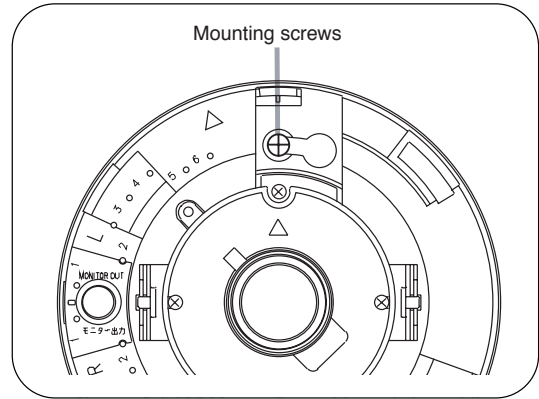
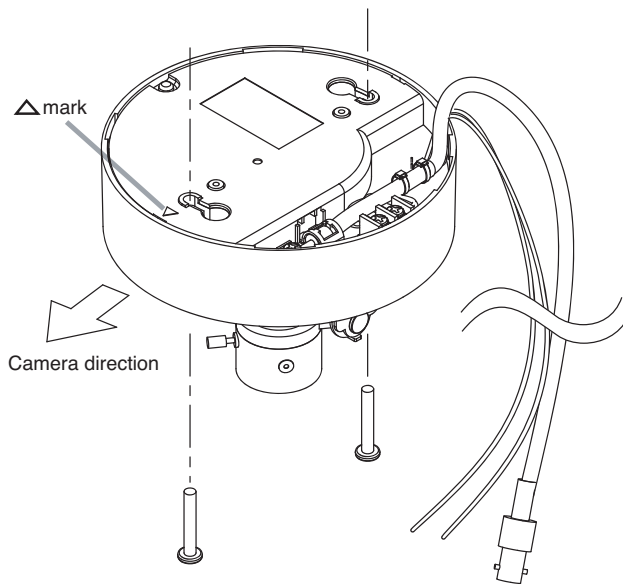

Note

Ensure that the mounting screws are set securely in their corresponding camera mounting holes.



WARNING

Be sure to use the optional ceiling bracket whenever the ceiling panel material seems too weak to securely mount the camera.

3. Adjust the camera's angle of view and focus, then attach the dome cover.

3-1. Align the camera head assembly with the inner cover.

Note the position of the ∇ mark on the camera head assembly (indicated in the figure as "3" in the "R" range), and align the camera's scale with that of the inner cover.

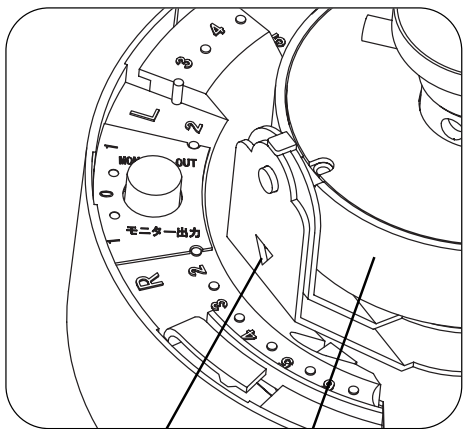

∇ mark Camera head assembly

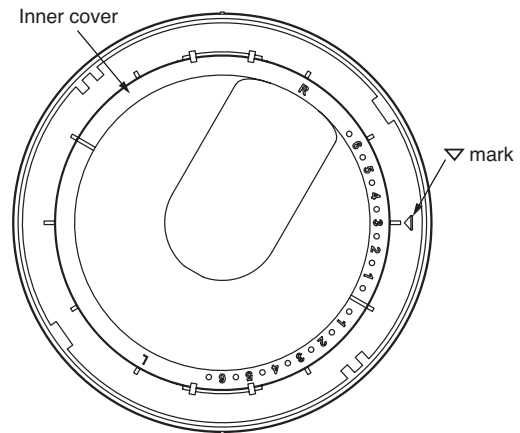

Rotate the inner cover to the "R" range, and align the ∇ mark with scale indicator "3."

Inner Cover Adjustment

Note: Take care not to touch the dome cover window (transparent section) during adjustment.

1. Hold the dome cover so that the ▽ mark is positioned as shown in the figure below.
2. Rotate the dome inner cover with the thumbs of both hands to align the scale.
3. Attach the dome cover to the camera.

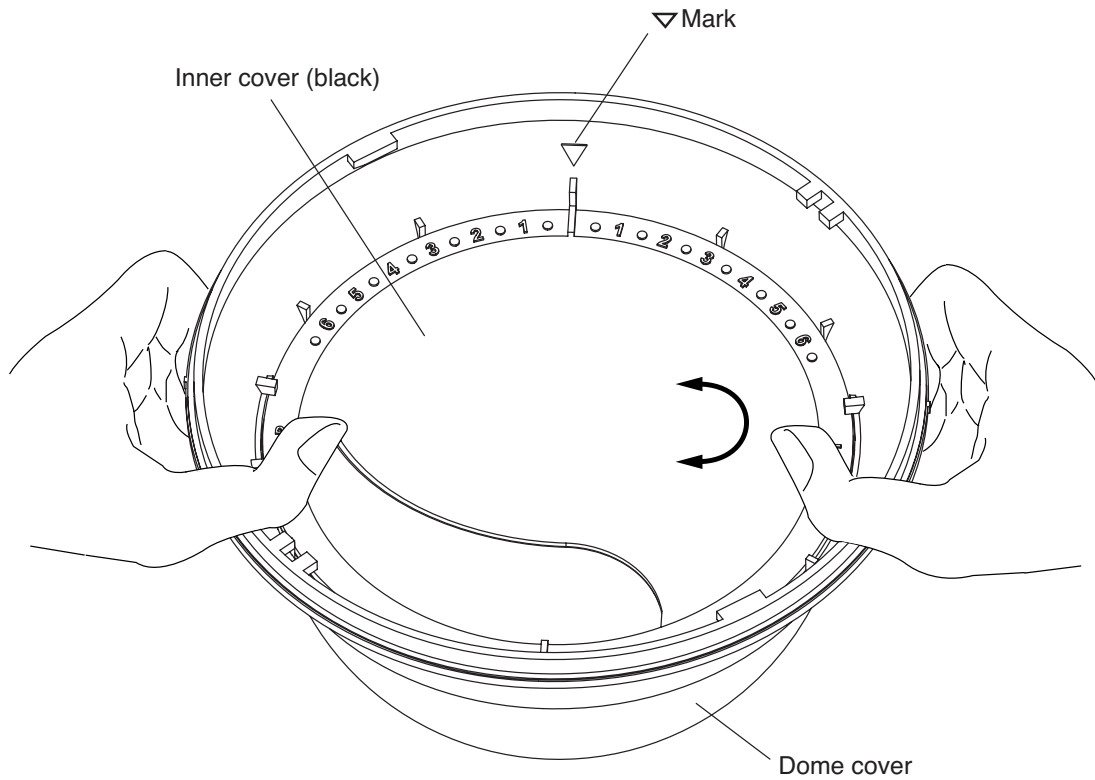

- 3-2. Attach the dome cover to the camera by aligning the dome cover's alignment mark with the camera's \triangle mark and then rotating the cover clockwise.
 (Be sure that the dome cover's alignment mark is properly aligned with the camera's alignment mark.)

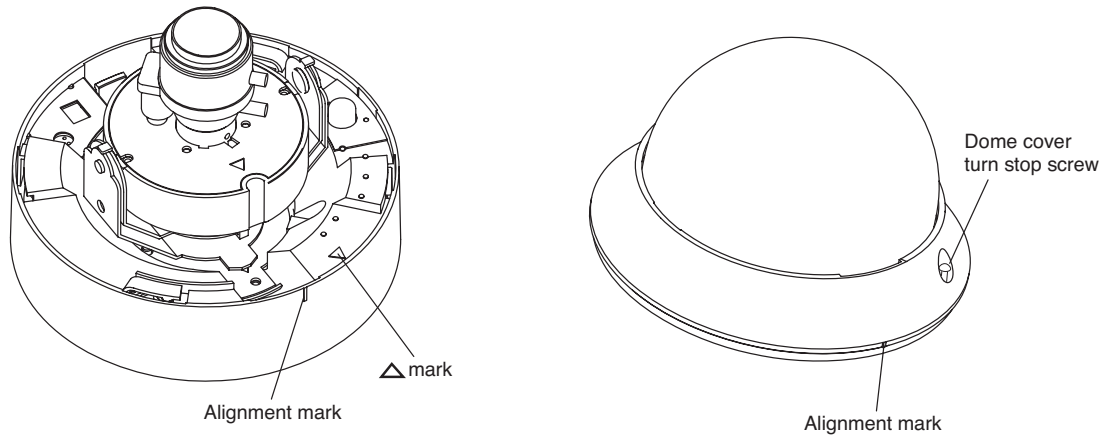

About the alignment marks

The dome cover has two alignment marks. Note that the mark to be aligned with the camera's \triangle mark differs depending on whether the camera is being mounted on a wall or ceiling.

Dome cover external view (as supplied from the factory)

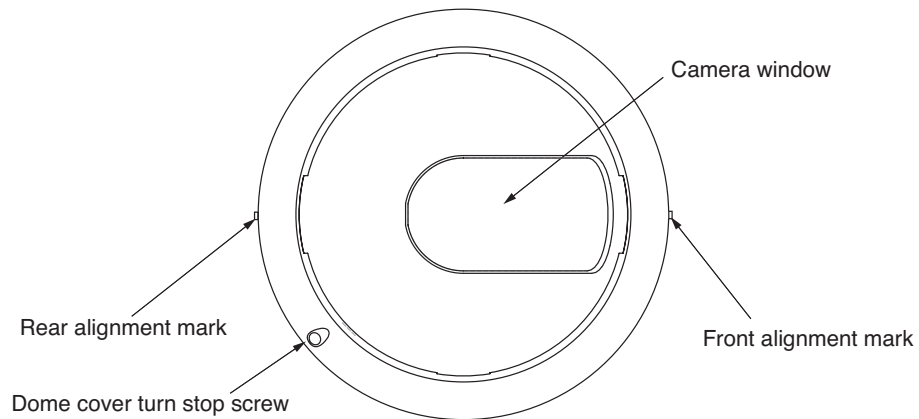

- Ceiling mounting : Align the front alignment mark with the camera's \triangle mark.
- Wall mounting : Align the rear alignment mark with the camera's \triangle mark.

6. CONNECTIONS

Note: If the Video output is not terminated at 75Ω , video pictures are not properly displayed.
 Make sure that the output has been terminated at 75Ω at the connected monitor or switcher.

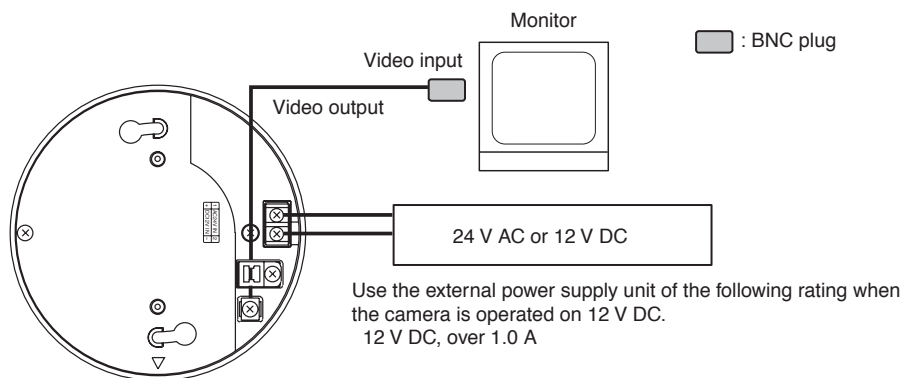

7. ADJUSTMENT

1. Switch on the camera power after completing camera connections.
Power is supplied to the camera.
2. Normally, set the Shutter Speed switch to "1/60" position.
Flickering of the picture may interfere with the view under fluorescent lamp in the area with power frequency of 50 Hz. In such cases, set the switch to "1/100" position, and the image free from flickering can be obtained.

Note

If the Shutter Speed switch of the Mode Setting switch is set to the ON position, sensitivity is reduced compared to operation in the OFF position. When using the camera in a dark location, or where light flicker is not an annoyance, set the switch to the OFF position.

3. Connect the monitor to the Monitor Output terminal to permit a picture to be viewed on the monitor.
4. Adjust the camera angle.
Camera angle can be adjusted for up to $130^{\circ}(\pm 65^{\circ})$ for horizontal rotation, for up to $140^{\circ}(\pm 70^{\circ})$ for vertical rotation, and for up to $180^{\circ}(\pm 90^{\circ})$ for picture tilting.

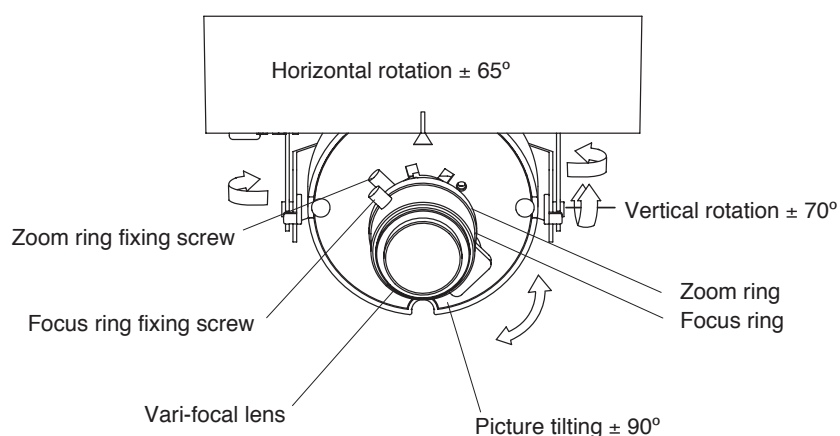

5. Adjust the angle of view with the Zoom ring and adjust the focus with the Focus ring for the best possible picture reproduction. After lens adjustment completion, tighten both the Zoom ring fixing screw and the Focus ring fixing screw.

Notes

- Since the Iris control is factory-preset to an optimum position for general use, avoid tampering with it in normal conditions. Turning the control unnecessarily could cause reduced picture quality or equipment failure. When the Iris control needs to be readjusted to match a specific subject, first set both the Adjustment switch and the Backlight Correction switch of the Mode setting switch to the OFF position, then adjust the control to an optimum level. After adjustment, place a hand over the lens for several seconds and then release to check the lens for correct iris operation.
- If the focus is adjusted for a subject under good lighting conditions, the subject may go out of focus when conditions become dark. To avoid this, adjust the lens focus after setting the Adjustment switch of the Mode setting switch to the ON position. Be sure to switch it back to the OFF position after completing lens adjustment.

6. Attach the dome cover to the camera after completing all necessary adjustments.

8. ABOUT THE MODE SETTING SWITCH

Set the Mode Setting switch for the best possible picture reproduction depending on installation conditions.

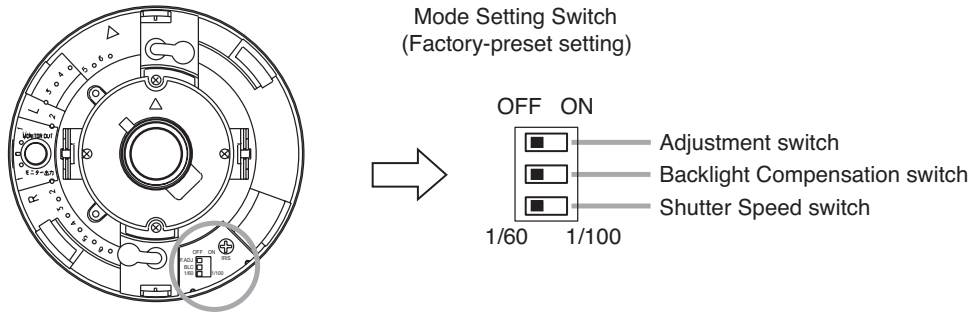

8.1. Adjustment Switch

Set this switch when adjusting the lens focus.(Provides the same effect as when using the ND filter.)



Standard position :

Set to OFF after lens adjustment completion. Set to this position during normal use.



Adjustment position (during adjustment) :

Use this position when focusing the lens. If the focus is adjusted for a subject under good lighting conditions, the subject may go out of focus when conditions become dark. Set the Adjustment switch to ON only when performing focus adjustment.

Note: The color of the screen may periodically vary under fluorescent lighting when the Adjustment switch is set to ON.

8.2. Backlight Compensation Switch

Set this switch so that the subject is not displayed in black when backlit.



Standard position :

Set to this position during normal use. Backlight Compensation function does not operate when the switch is set to this position.



Backlight Compensation position (when backlit) :

This position prevents images from being displayed in black when the image is backlit.

8.3. Shutter Speed Switch

Set this switch to the ON position when annoying screen image flicker is detected.



Standard position :

Set to this position during normal use.

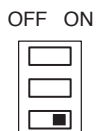

Shutter Speed position :

Annoying screen flicker may result under fluorescent lighting in areas operating with a power frequency of 50 Hz. In such cases, set the Shutter Speed switch to the ON position to permit a flicker-free picture to be viewed.

Note: If the Shutter Speed switch is set to the ON position, sensitivity is reduced compared to operation in the OFF position. When using the camera in a dark location, or where light flicker is not an annoyance, set the switch to the OFF position.

9. IF YOU THINK THERE IS A FAILURE: (TROUBLESHOOTING)

Symptom	Possible Cause	Remedy
Camera images are not displayed on the monitor.	<ul style="list-style-type: none">• The monitor's power switch is not set to ON.• Cables are not correctly connected.• The BNC plug is not correctly soldered.• Power is not supplied to the camera.	<ul style="list-style-type: none">• Turn on the power switch.• Connect correctly.• Solder correctly.• Switch on the power.
Pictures are not clear.	<ul style="list-style-type: none">• The lens is not properly focused.• The lens is dirty.• Monitor image black level is not correctly adjusted.	<ul style="list-style-type: none">• Adjust the lens.• Wipe the lens.• Adjust the level correctly.
The color of the picture periodically varies.	<ul style="list-style-type: none">• The Adjustment switch is set to the ON position.	<ul style="list-style-type: none">• Set the Adjustment switch to the OFF position.

10. SPECIFICATIONS

Model No.	C-CV24-3 (CU)	C-CV24-2 (NTSC)
Power Source	24 V AC, 50/60 Hz or 12 V DC	
Power Consumption	2 W (maximum current: 800 mA)	
Image Device	1/4 type IT-CCD	
Number of Effective Pixels	768 (H) x 494 (V), 380,000 pixels	
Scanning System	2:1 interlace	
Scanning Frequency	H: 15.734 kHz, V: 59.94 Hz	
Monitor Output	VBS1.0 V(p-p), 75 Ω, RCA pin jack	
Video Output	VBS1.0 V(p-p), 75 Ω, BNC-R jack	
Synchronizing System	Internal synchronization	
Resolution (at center)	H: 480 lines, V: 350 lines	
S/N Ratio	48 dB	
Minimum Illumination	3 lx (50 IRE)	
White Balance Mode	ATW	
Focal Length	f=3.3 mm – 12.0 mm	f=2.0 mm – 4.0 mm
Maximum Aperture Ratio	1:1.4 – 2.9	1:1.4 – 1.8
Iris	Auto-iris	
Angle of View	H: 63.6°– 17.9°, V: 46.5°– 13.5°	H: 105.1°– 53.2°, V: 77.4°– 39.8°
Control Switch	ON/OFF (used for focus adjustment)	
Other Functions	Backlight compensation, Shutter speed (1/60, 1/100), Iris control	
Operating Temperature	– 10°C to + 50°C (14°F to 122°F)	
Operating Humidity	90% RH or less (no condensation)	
Finish	Case : ABS resin, light gray, Dome cover : Acrylic resin	
Dimensions	ø118 x 97 (H) mm (ø4.65 x 3.82 (H) inch)	
Weight	370 g (0.82 lb)	
Applications	Indoor use	

The specifications of this camera are subject to change without notice.

Note

No camera mounting screws are supplied. For mounting, use screws of 4 x 25 mm (0.16" x 0.98") or longer.

• Optional Products

Flush ceiling mounting bracket: C-BC20U



TOA Corporation

URL: <http://www.toa.jp/>

133-22-175-00

Free Manuals Download Website

<http://myh66.com>

<http://usermanuals.us>

<http://www.somanuals.com>

<http://www.4manuals.cc>

<http://www.manual-lib.com>

<http://www.404manual.com>

<http://www.luxmanual.com>

<http://aubethermostatmanual.com>

Golf course search by state

<http://golfingnear.com>

Email search by domain

<http://emailbydomain.com>

Auto manuals search

<http://auto.somanuals.com>

TV manuals search

<http://tv.somanuals.com>