

Defiant Non-Catalytic Woodburning Stove

Model 1610CE

Homeowner's
Installation and
Operating Manual

For use in Europe



SAFETY NOTICE: IF THIS APPLIANCE IS NOT PROPERLY INSTALLED, OPERATED AND MAINTAINED, A HOUSE FIRE MAY RESULT. TO REDUCE THE RISK OF FIRE, FOLLOW THE INSTALLATION INSTRUCTIONS. FAILURE TO FOLLOW INSTRUCTIONS MAY RESULT IN PROPERTY DAMAGE, BODILY INJURY OR EVEN DEATH. CONTACT LOCAL BUILDING OFFICIALS ABOUT RESTRICTIONS AND INSTALLATION INSPECTION REQUIREMENTS IN YOUR AREA.

Do Not Discard This Manual: Retain for Future Use

30003846 4/08 Rev. 1

Welcome

Congratulations on your choice of a Vermont Castings Defiant stove. With this purchase you have made a commitment to make the hearth a place of warmth, beauty and comfort in your home. At CFM Corporation, we share that joy and appreciation for the hearth. We assure you that your cast-iron Vermont Castings stove has been made with the utmost care and will provide you with many years of service.

As you become acquainted with your new stove, you will find that its appearance is matched by its functionality, due to cast iron's unique ability to absorb and radiate heat.

Also, CFM Corporation products are among the cleanest-burning wood stoves and fireplaces available today. As an owner of a Vermont Castings stove, you make a strong statement for pollution-free energy. However, clean burning depends on both the manufacturer and the operator. Please read this manual carefully to understand how to properly operate and maintain your stove.

At CFM Corporation, we are equally committed to your satisfaction as a customer. That is why we maintain an exclusive network of the finest dealers in the industry. Our dealers are chosen for their expertise and dedication to customer service. They are factory-trained and knowledgeable about every CFM Corporation product. Feel free to contact your Authorized Vermont Castings Dealer anytime you have a particular question about your stove or its performance.

This manual contains valuable instructions on the installation and operation of your Vermont Castings Defiant. It also contains useful information on maintenance. Please read the manual thoroughly and keep it as a reference.

Sincerely,

All of Us at CFM Corporation

This manual describes the installation, operation, and maintenance of the Vermont Castings Defiant Model 1610CE non-catalytic wood burning heater. This heater meets the U.S. Environmental Protection Agency's emission limits for wood heaters sold on or after July 1, 1990. Under specific test conditions this heater has been shown to deliver heat at rates up to 14.5 kW (49,500 BTU/hr).

The Defiant Model #1610CE has been tested to current standards. The test standards are UL-1482 and UL-737 for the United States, and EN13240:2001 + A2:2004 for Europe. The Defiant is listed for burning wood only. Do not burn other fuels. The Defiant is not approved for use in manufactured (mobile) homes.

We recommend that you hire a professional installer to install your stove, or to advise you on the installation should you attempt to install it yourself.

Please read this entire manual before you install and use your new stove. Failure to follow instructions may result in property damage, bodily injury, or even death.

Save These Instructions for Future Reference

The Story of the Defiant

No wood-burning appliance, save for Ben Franklin's Pennsylvania Fireplace, has a stronger heritage than the Vermont Castings Defiant. Named for a 19th-century steamship, the original Vermont Castings Defiant Wood Stove came to epitomize America's resolve and independence during the Energy Crisis of the 1970s.

The year was 1975. With energy prices going through the roof, without an attractive or efficient wood stove to be found anywhere, two entrepreneurs set out to create a stove that was both beautiful and highly functional. Finely crafted from cast iron, the Defiant was the first wood stove to combine an artistically designed exterior with a methodically engineered interior, using new technologies for efficient combustion.

Americans purchased over a quarter-million Defiants, as they rediscovered the common sense of heating with wood, a home-grown fuel with none of the political and economic entanglements of foreign oil.

Thirteen years later, in 1988, Vermont Castings 'retired' the Defiant, replacing it with modern wood-burners such as the Encore.

With its 1998 return, a new Defiant incorporated all the finest aesthetic, convenience, and performance features to be found on any wood stove. After continued development, this Defiant model 1610CE non-catalytic model continues the tradition of the original Defiant while incorporating the very latest combustion technology. In a sense, the new Defiant has been 23 years in the making.

Due to its significant role in American history, the original model Defiant is in the permanent collection of the Smithsonian Institution. Each new purchase of the Defiant stove continues that history.

Table of Contents

Specifications	4
Installation	5
Assembly	12
Operation.....	14
Draft Management.....	19
Maintenance	21
Replacement Parts	25
Warranty	28

Installation Accessories

Warming Shelf

- #0210 Classic Black
- #0211 Biscuit
- #0212 Midnight Blue
- #0213 Ebony
- #0214 Bordeaux
- #0215 Chestnut Brown
- #0216 Vt. Classic Green
- #3265 Outside Air Kit
- #1860 6" x 12" Oval Starter Pipe
- #2767 Fan Kit
- #0178 Flue Collar Heat Shield
- #0168 Connector Pipe Heat Shield

A line of porcelain enamel stove pipe is available in Biscuit, Bordeaux, Chestnut Brown, Ebony, Midnight Blue, Vt. Classic Green colors.

Specifications

Defiant, Model 1610CE

Nominal heat output 14.5 kW (49,500 BTU/hr)¹
 Minimum flue draught..... 12 Pa (0.048" WG)
 Mean flue gas temp..... 419° C (786° F)
 Efficiency (space heating) 72.3%
 Area heated 223 sq m (2,400 sq. ft.)¹
 Fuel size/type 610 mm (24") wood
 Flue mass gas flow 10.8 g/s
 CO emissions (@13% O₂)..... 1600 ppm
 Loading..... Front and top
 Chimney Connector:
 for 8" flue collar 203 mm (8") diameter
 Chimney Flue Size:
 with 8" Chimney Connector.. 203 mm (8") minimum
 with 6" Chimney Connector.. 152 mm (6") minimum
 Flue exit position Top or Rear
 Primary Air Manual control
 Secondary Air Fixed, self-regulating
 Ash handling system Removable ash pan
 Glass panels..... High-temperature ceramic

Weight 222 kg (490 lbs)
 Width (leg to leg) 822 mm (32 3/8")
 Depth (leg to leg)..... 483 mm (19")
 Height to top of flue collar..... 759 mm (29 7/8")

1. This value can vary depending on how the stove is operated, the type and moisture content of the fuel used, as well as the design, construction and climatic location of your home. Figures shown are based on nominal fuel consumption obtained under laboratory conditions and on average efficiencies.

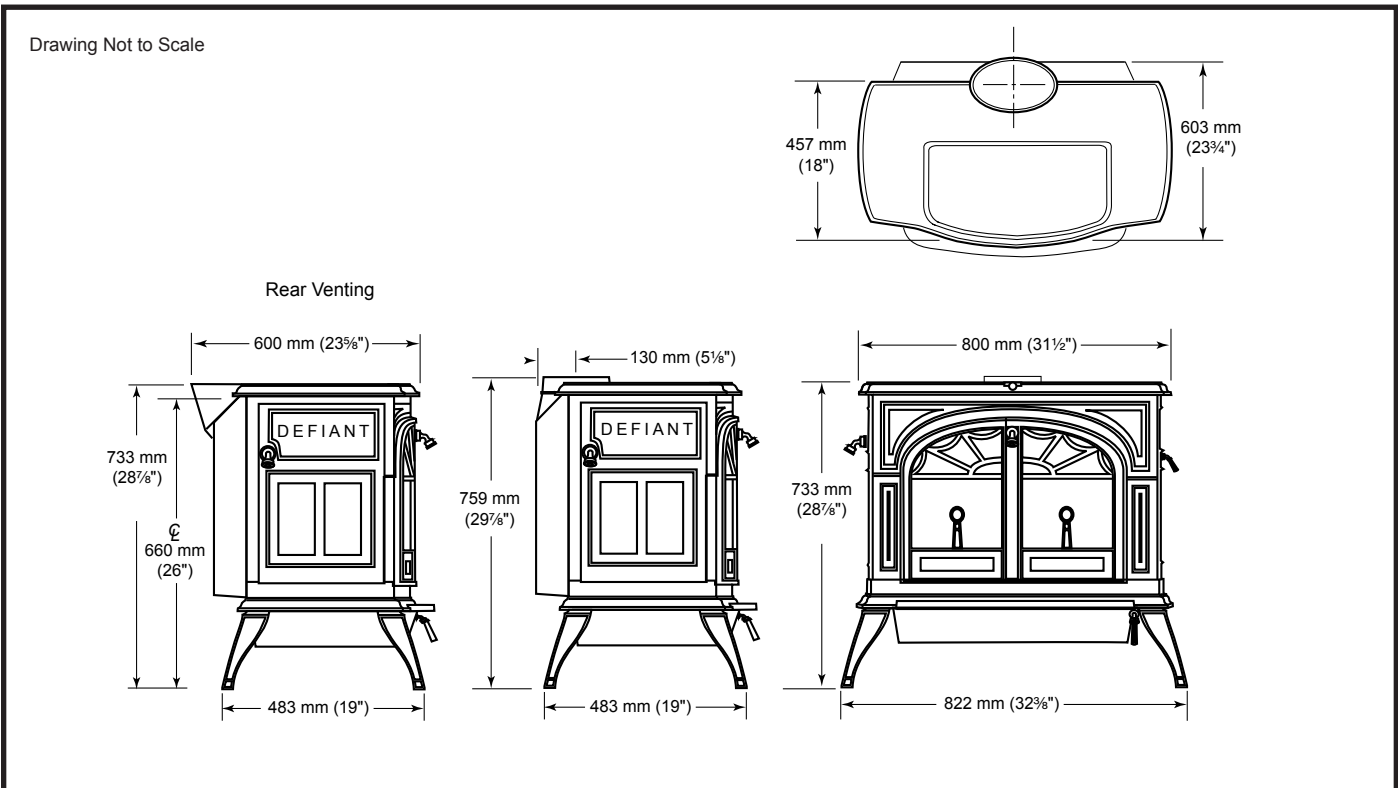

Fig. 1 Defiant NC dimensions.

Installation

SAFETY NOTICE: IF YOUR DEFIANT IS NOT PROPERLY INSTALLED, A HOUSE FIRE MAY RESULT. TO REDUCE THE RISK OF FIRE, FOLLOW THE INSTALLATION INSTRUCTIONS. CONTACT LOCAL BUILDING OR FIRE OFFICIALS ABOUT RESTRICTIONS AND INSTALLATION INSPECTION REQUIREMENTS IN YOUR AREA.

Before you begin an installation, be sure that:

- Your stove and chimney connector will be far enough from combustible material to meet all clearance requirements.
- The floor protector is large enough and is constructed properly to meet all requirements.
- You have all necessary permits from local authorities.

Your local building official is the final authority for approving your installation as safe and determining that it meets local and state codes.

The metal label permanently attached to the back of every Vermont Castings' stove indicates the stove has been tested to current standards. The test standard is EN13240:2001 + A2:2004 for Europe. Clearance and installation information also is printed on the label. When the stove is installed according to the information both on the label and in this manual, local authorities usually will accept the label as evidence that the installation meets codes and can be approved.

However, codes vary in different countries. Before starting the installation, review your plans with the local building authority. Your local dealer can provide any additional information needed.

IMPORTANT: Failure to follow these installation instructions may result in a dangerous situation, including a chimney or house fire. Follow all instructions exactly, and do not allow makeshift compromises to endanger property and personal safety.

All local regulations, including those referring to national and European standards need to be complied with when installing this stove.

Outside Air

In some modern, super-insulated homes, there may be inadequate air supply for combustion because of insufficient air infiltration into the building. Such air enters a home through unsealed cracks and openings. Exhaust fans in kitchens or bathrooms can compete with the stove for available air and compound the problem.

When poor draft is caused by a low infiltration rate, opening a ground floor window on the windward side of the house and near the stove will usually alleviate the problem.

For appliances with power outputs above 5 kW a permanently open air vent is required by Section 2 of Document J. Air inlet grilles should be positioned so that they will not be blocked. Refer to local and national codes for recommended configurations.

Pressure variations within the house do not affect a stove equipped with an outside air supply, and improved stove performance often results. An Outside Air Kit for the Defiant is available from your local dealer.

Chimney Height

Altitude affects chimney performance. When using a 203 mm (8") oval to 152 mm (6") flue collar adapter on the Defiant, refer to Figure 1 for suggested chimney heights at various altitudes. Chimney height should be measured from the flue collar to the top of the chimney. The recommended minimum chimney height is 4.8 m (16").

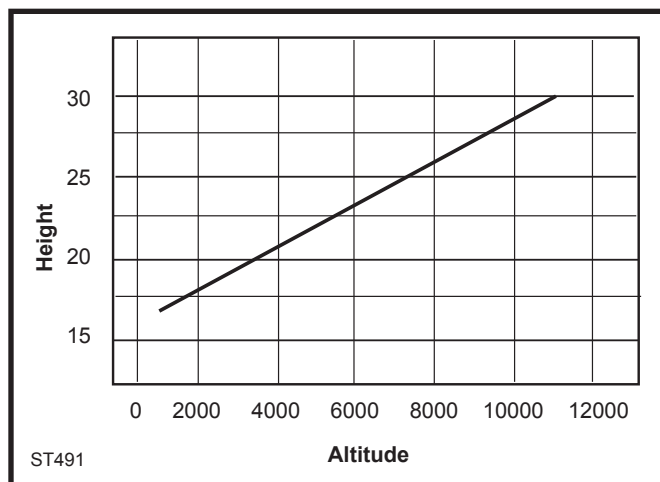

Fig. 2 Chimney height requirements with 152 mm (6") chimney and/or chimney connector.

What Kind of Chimney to Use

You must connect the Defiant to a code-approved masonry chimney with a flue liner, to a relined masonry chimney that meets local codes, or to a prefabricated metal chimney. Figure 3 illustrates the two types. The chimney and chimney connector must be in good condition and kept clean.

If you use an existing masonry chimney, it must be inspected to ensure it is in a safe condition before the stove is installed. Your local professional chimney sweep, building inspector, or fire department official will be able to inspect the chimney or provide a referral to someone who can. See "Chimney and Fireplace hazards", in the appendix, for particulars.

The flue and chimney design must meet requirement J2, Part J of the building regulations 2000 (Combustion Appliances and Fuel Storage Systems).

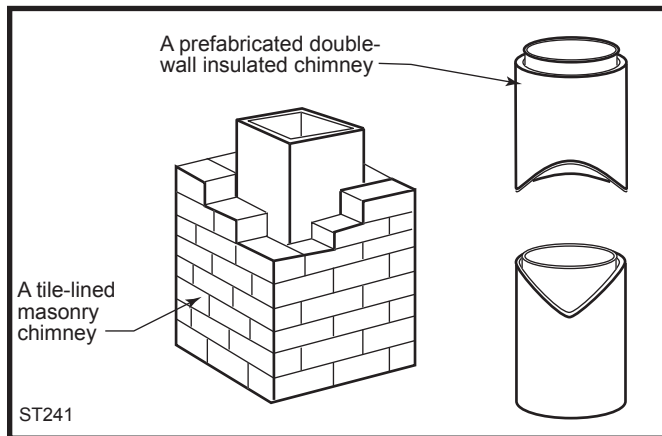

Fig. 3 Approved chimney types.

Masonry Chimneys

An inspection of the chimney must confirm that it has a lining. Do not use an unlined chimney. The chimney should have no cracks, loose mortar, other signs of deterioration, and blockage. Repair any defects before the chimney is used with your stove.

Unused openings in an existing masonry chimney must be sealed with masonry to the thickness of the chimney wall, and the chimney liner should be repaired. Openings sealed with pie plates or wallpaper are a hazard and should be sealed with mortar or refractory cement. In the event of a chimney fire, flames and smoke may be forced out of these unused thimbles.

The chimney should be thoroughly cleaned before use.

A newly-built masonry chimney must conform to the standards of your local building code or, in the absence of a local code, to a recognized national code. Masonry chimneys must be lined, either with code-approved masonry or pre-cast refractory tiles, stainless steel pipe, or a code-approved, "poured-in-place" liner. The

chimney's clean-out door must seal tightly. A loose or leaky clean-out door can weaken chimney draft, causing performance problems.

Prefabricated Chimneys

These should be an internal diameter of 150 mm (6") and be of the twin wall insulated construction that has been approved for solid fuel use (e.g. Rite Vent ICS of ICID Lite Chimney Systems). Diameters over 200 mm (8") are not recommended due to the large cross-section causing excessive cooling of the flue gases.

DO NOT CONNECT THIS UNIT TO A CHIMNEY FLUE SERVING ANOTHER APPLIANCE.

Chimney Size

A Defiant with an 203 mm (8") flue collar is approved for venting into a masonry chimney with a nominal flue size of 203 x 203 mm (8" x 8") or 203 x 305 mm (8" x 12"), and into a round flue with nominal flue size of 203 mm (8"). A Defiant with a 152 mm (6") flue connector is approved for venting into a masonry chimney with a nominal flue size of 203 x 203 mm (8" x 8"), and into a round flue with nominal flue of 152 mm (6").

NOTE: When installed with a 152 mm (6") flue collar, the Defiant may not be operated with the front doors open.

Whatever the flue collar size, a Defiant may be vented into larger chimneys as well. However, chimneys with liners larger than 203 x 305 mm (8" x 12") may experience rapid cooling of smoke and reduction in draft, especially if the chimneys are located outside the home. These large chimneys may need to be insulated or have their flues relined for proper stove performance.

Accessories to help make the connection between stainless steel chimney liners and your Defiant are available through your local dealer.

Chimney Connector Guidelines

A chimney connector is the single-wall pipe that connects the stove to the chimney. The chimney itself is the masonry or prefabricated structure that encloses the flue. Chimney connectors are used only to connect the stove to the chimney.

Connecting Flue Pipes

Connector pipes should meet the requirements of the building regulations. This can be achieved by the use connecting fluepipes included in the following categories:

- Vitreous enamelled steel pipe complying with BS 6999: 1989 (1996);
- Pipes made from stainless steel as described in BS EN 1008-1:1995 grades 1.4401, 1.4404, 1.4432 or 1.4436 with flue wall thickness of at least 1 mm;

- c) Mild steel fluepipes complying with BS 1449: Part 1: 1991, with a flue wall thickness of at least 3 mm;
- d) Cast iron fluepipes complying with BS 41: 1973 (1998).

Flue Pipes with a spigot and socket joint should be fitted with the socket facing upwards, to contain condensates and moisture within the flue. Joints should be made gas tight using proprietary jointing accessories, or, where appropriate, by packing joint with noncombustible rope and fire cement.

Single-wall connectors should be made of 24 gauge or heavier steel. Do not use galvanized connector; it cannot withstand the high temperatures that can be reached by smoke and exhaust gases, and may release toxic fumes under high heat. The connector may be 152 mm (6") or 203 mm (8") in diameter.

If possible, do not pass the chimney connector through a combustible wall or ceiling. If passage through a combustible wall is unavoidable, refer to the section on Wall Pass-Throughs. Do not pass the connector through an attic, a closet or similar concealed space. The whole connector should be exposed and accessible for inspection and cleaning.

In horizontal runs of un shielded chimney connector, maintain a distance of 762 mm (30") from the ceiling. Keep it as short and direct as possible, with no more than two 90° turns. Slope horizontal runs of connector upward 6mm per meter (1/4" per foot) going from the stove toward the chimney. The recommended maximum length of a horizontal run is 914 mm (36"), and the total length should be no longer than 2.4 m (8'). In cathedral ceiling installations, extend the prefabricated chimney downward to within 2.4 m (8') of the stove. This will help maintain a good draft by keeping the smoke warm, so that it rises readily.

Wear gloves and protective eyewear when drilling, cutting or joining sections of chimney connector.

Single-wall Chimney Connectors

- Begin assembly at the flue collar of the stove. Insert the first crimped end into the stove's flue collar, and keep each crimped end pointing toward the stove. (Fig. 4) Using the holes in the flue collar as guides, drill 3 mm (1/8") holes in the bottom of the first section of chimney connector and secure it to the

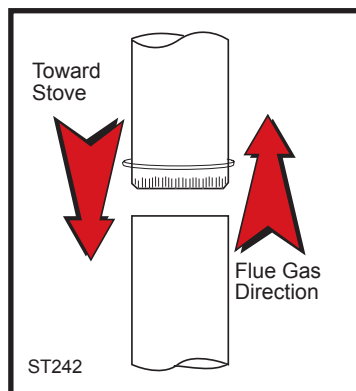

Fig. 4 Chimney connector.

flue collar with three #10 x 1/2" sheet metal screws. Lift off the griddle, and shield the stove's surface between the griddle opening and the front of the flue collar to protect the finish when you drill the front hole.

- Fasten each joint between sections of chimney connector, including telescoping joints, with at least three (3) sheet metal screws. The pre-drilled holes in the top of each section of chimney connector serve as guides when you drill 3 mm (1/8") holes in the bottom of the next section.
- Fasten the chimney connector to the chimney. Instructions for various installations follow. Figure 6 illustrates the general layout of chimney connector parts.
- Be sure the installed stove and chimney connector are correct distances from nearby combustible materials.

NOTE: Special slip pipes and thimble sleeves that form telescoping joints between sections of chimney connector are available to simplify installations. They often eliminate the need to cut individual connector sections. Consult your local dealer about these special pieces.

Securing the Single-wall Connector to a Prefabricated Chimney

Follow the installation instructions of the chimney manufacturer exactly as you install the chimney. The manufacturer of the chimney will supply the accessories to support the chimney, either from the roof of the house, at the ceiling of the room where the stove is installed, or from an exterior wall.

Special adapters are available from your local dealer to make the connection between the prefabricated chimney and the chimney connector. The top of such adapters attaches directly to the chimney or to the chimney's ceiling support package, while the bottom of the adapter is screwed to the chimney connector.

These adapters are designed so the top end will fit outside the inner wall of the chimney, and the bottom end will fit inside the first section of chimney connector.

Securing the Single-wall Connector to a Masonry Chimney

Both freestanding masonry chimneys and fireplace masonry chimneys may be used for your installation.

Freestanding Installations

If the chimney connector must pass through a combustible wall to reach the chimney, follow the recommendations in the Wall Pass-Through section that follows. The opening through the chimney wall to the flue (the "breach") must be lined with either a ceramic or metal cylinder, called the "thimble", which is cemented

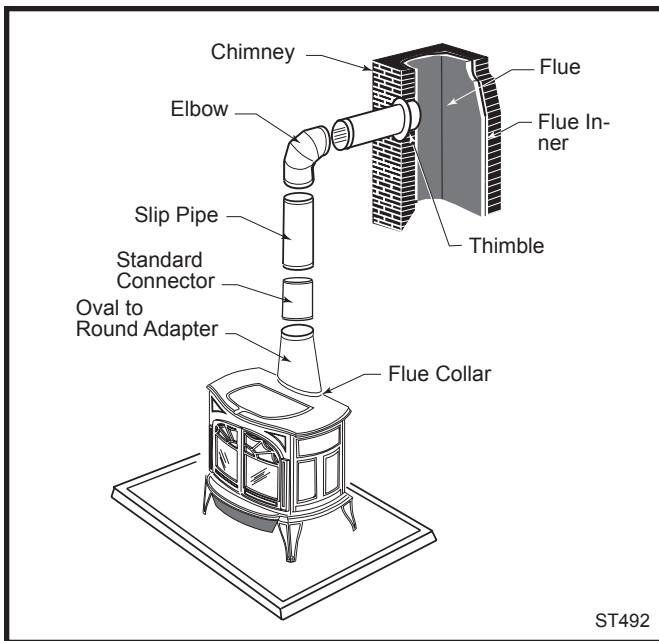

Fig. 5 An exploded view of the chimney connection in a free-standing masonry installation.

securely in place. Most chimney breeches incorporate thimbles, but the fit must be snug and the joint between the thimble and the chimney wall must be cemented firmly.

A special piece called the “thimble sleeve,” slightly smaller in diameter than standard connectors and most thimbles, will facilitate the removal of the chimney connector system for inspection and cleaning. (Fig. 6) Thimble sleeves are available from your local dealer.

To install a thimble sleeve, slide it into the breech until it is flush with the inner flue wall. Do not extend it into the actual flue passage, as this could interfere with the draft.

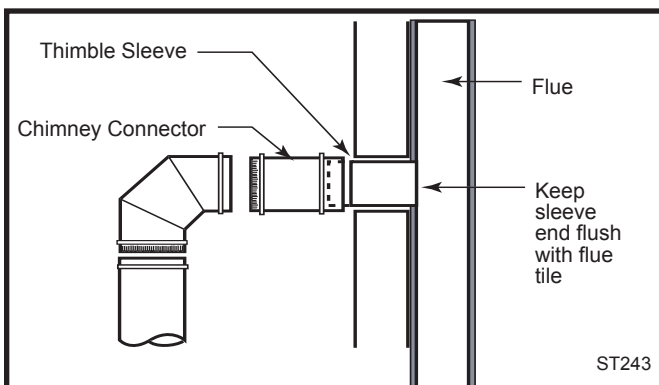

Fig. 6 The thimble, made of either ceramic or metal, must be cemented securely in place.

The thimble sleeve should protrude 25-51 mm (1-2”) into the room. Use furnace cement and thin gasketing to seal the sleeve in place in the thimble. Secure the chimney connector to the outer end of the sleeve with sheet metal screws.

Without a thimble, a suitable length of chimney connector can be extended through the breech to the inner face of the flue liner, and cemented securely in place. Additional pieces of connector are then attached with sheet metal screws.

Fireplace Installations

The chimney connector may be connected to the chimney above the fireplace opening or through the fireplace.

Above the Fireplace

The Defiant may be connected to a chimney above a fireplace opening. (Fig. 7) In such installations, the stove is positioned on the hearth in front of the fireplace and the chimney connector rises from the stove top and then angles ninety degrees back into the chimney. The chimney liner should extend to the point at which the chimney connector enters the chimney.

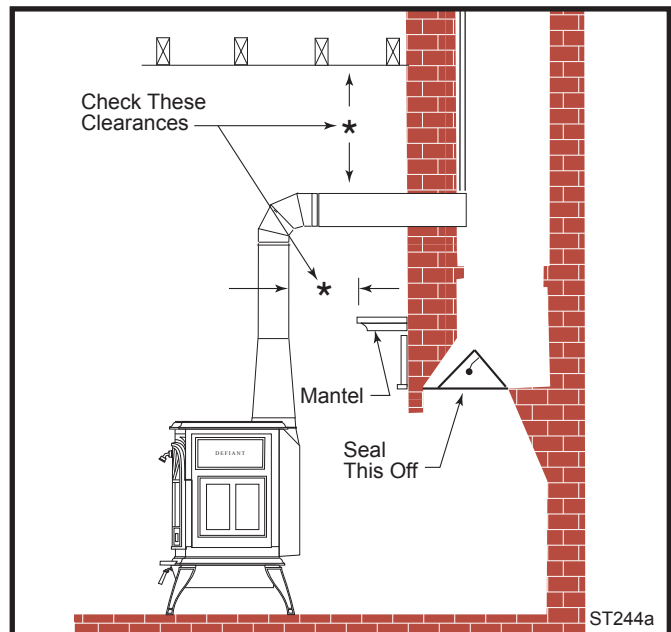

Fig. 7 In this installation, the chimney connector attaches to the chimney above the fireplace opening.

If the chimney connector in your installation enters the chimney above a fireplace, follow all the guidelines mentioned above for freestanding installations. In addition, give special consideration to the following points:

- Check the clearance between the stove and the chimney connector, and any combustible trim or the mantel.
- Check the clearance between the chimney connector and the ceiling. The clearance should be at least 762 mm (30”) with unshielded connectors. Consult the clearance charts for other installation options.
- The fireplace damper must be sealed to prevent room air from escaping up the flue. However, it must be possible to re-open the damper to inspect or clean the chimney.

Through the Fireplace

If your fireplace opening height is at least 737 mm (29"), you may install a Defiant through the opening using a "positive connection" kit, available from your local dealer. Positive connection kits ensure a tight fit between the stove flue collar and the chimney flue. (Fig. 8)

Fireplace installations, whether connected to the flue above or through the fireplace opening, have special clearance requirements to adjacent trim and the mantel. You'll find the required safe clearances for Defiant fireplace installations on Page 12.

Floor protection requirements also apply to fireplace installations.

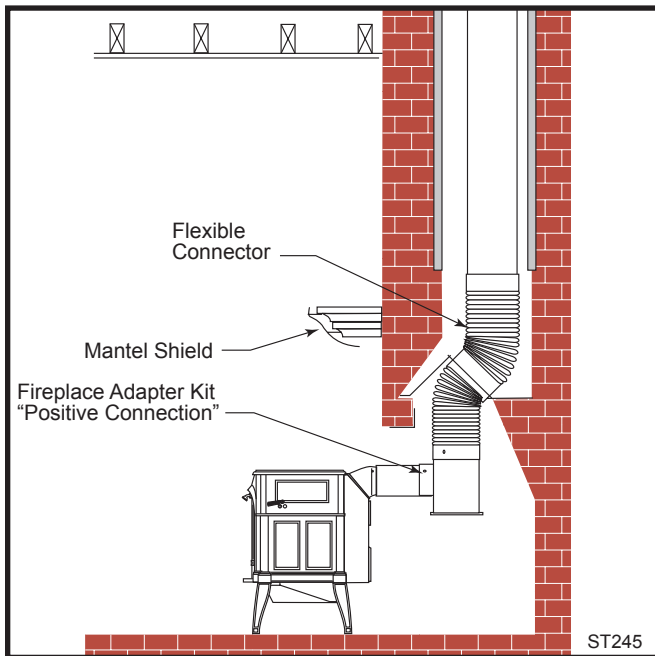

Fig. 8 Through the fireplace installation.

Wall Pass-Throughs

Whenever possible, design your installation so the connector does not pass through a combustible wall. If you are considering a wall pass-through in your installation, check with your building inspector before you begin. Also, check with the chimney connector manufacturer for any specific requirements.

Accessories are available for use as wall pass-throughs. If using one of these, make sure it has been tested and listed for use as a wall pass-through.

Figure 9 shows one method of passing a connector through a wall. All combustible material in the wall is cut away to provide the required 457 mm (18") clearance for the connector. The resulting space must remain empty. A flush-mounted sheet metal cover may be used on one side only. If covers must be used on both sides, each cover must be mounted on noncombustible spacers at least 25 mm (1") clear of the wall.

Your local dealer or your local building inspector can provide details for other approved methods of passing a chimney connector through a combustible wall in your area.

DO NOT CONNECT THE DEFIANT TO ANY AIR DISTRIBUTION DUCT OR SYSTEM.

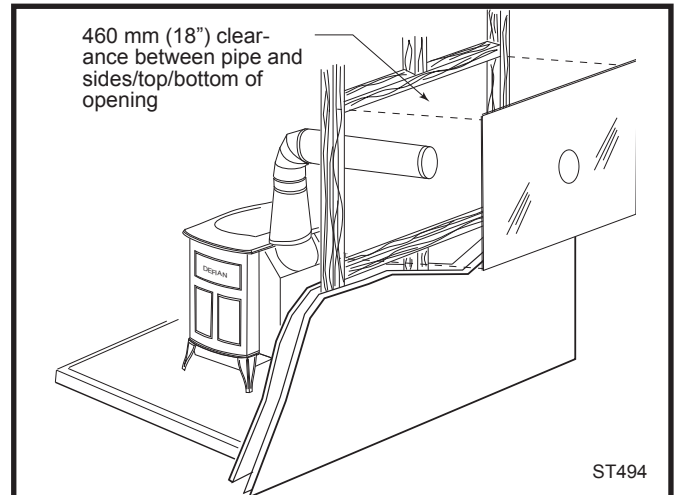

Fig. 9 An approved wall pass-through for Canada.

Hearths

This appliance must be installed on to hearth that meets the requirements of Part J of the Building Regulations 2000 (Combustion Appliances and Fuel Storage Systems). This can be achieved by ensuring that the hearth is constructed and sized in accordance with the guidelines included in section 2 of approved document 'J'. The size and clearances of the hearth are as follows:

The constructed hearth should be constructed in accordance with the recommendations in document J, and should be of minimum width 840 mm and minimum depth 840 mm (if a free standing hearth b) above) or a minimum projection of 150 mm from the jamb (if a recessed hearth a) above).

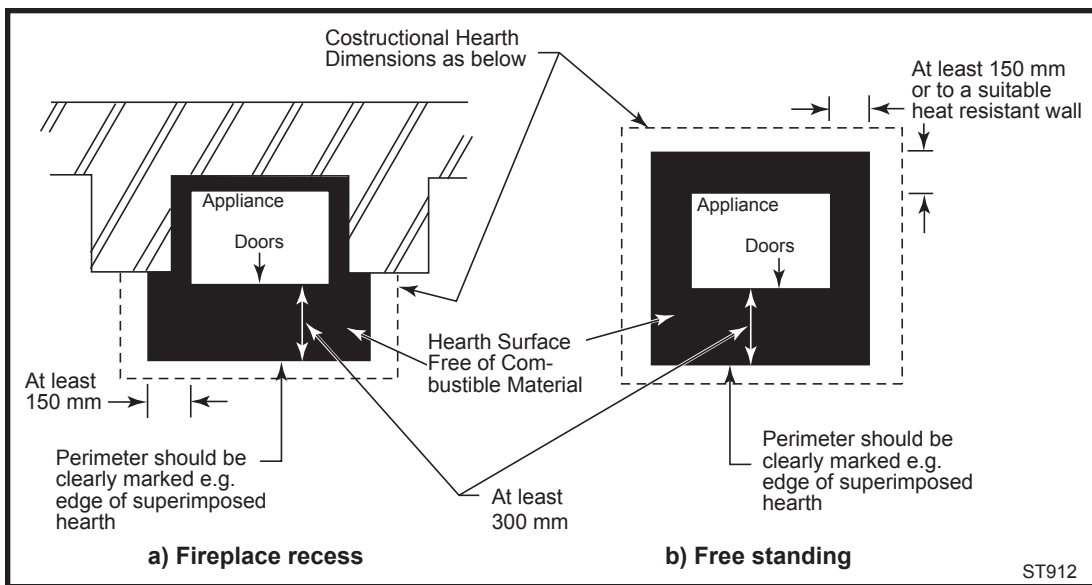

Fig. 10 Noncombustible hearth surface dimensions.

Floor Protection for Fireplace Installation

Do not assume that your fireplace hearth is completely noncombustible. Many fireplace hearths do not satisfy the “completely noncombustible” requirement because the brick or concrete in front of the fireplace opening is supported by heavy wood framing. Because heat passes readily through brick or concrete, it can easily pass through to the wood. As a result, such fireplace hearths can be a fire hazard and are considered a combustible floor.

For all fireplace installations, follow the floor protection guidelines described above, including the need for bottom and ash door heat shields. Keep in mind that many raised hearths will extend less than the required clearance from the front of the heater. In such cases, sufficient floor protection as described above must be added in front of the hearth to satisfy the minimum floor protector requirement from the front of the stove: 410 mm (16”). Hearth rugs do not satisfy the requirement for floor protection as they are not fire proof.

Fireplace installations also have special clearance requirements to the side walls, side decorative trim and fireplace mantel. Refer to the information on fireplace and mantel trim shields in this section.

Keep the Stove a Safe Distance From Surrounding Materials

Both a stove and its chimney connector radiate heat in all directions when operating, and nearby combustible materials can overheat dangerously if they are too close to the heat source. A safe installation requires that adequate clearance be maintained between the hot stove and its connector and nearby combustibles.

Clearance is the distance between either your stove or chimney connector, and nearby walls, floors, the ceiling, and any other fixed combustible surface. The Defiant has specific clearance requirements that have been established after careful research and testing. These clearance requirements must be strictly observed.

In addition, keep furnishings and other combustible materials away from the stove. In general, a distance of 1219 mm (48”) must be maintained between the stove and moveable combustible items such as drying clothes, furniture, newspapers, firewood, etc. Keeping those clearance areas empty assures that nearby surfaces and objects will not overheat.

Clearances

As with any solid fuel heating stove, extremely high surface temperatures can occur, particularly in the event of uncontrolled operation, e.g. if the doors are inadvertently left open. It is crucial that sufficient clearances are allowed to any combustible surfaces, e.g. wooden mantels or lintels, and to timber framed (studded) walls even if they are faced with noncombustible board. Detailed information on fireplace and hearth construction is provided in section 2 of Document J, all installations must comply with these requirements or with the relevant National or local building standards.

Clearances to timber framed (studded) walls are included below. There are no specific minimum clearances to solid noncombustible surfaces (e.g. the sides and rear of Inglenook fire openings constructed from solid masonry) other than to allow safe access to the controls of the stove. For this reason minimum side clearances of 125 mm, and a minimum rear clearance of 50 mm are recommended.

Summary of Clearances

Minimum recommended side clearances to non-combustible surfaces 125 mm (5").

Minimum recommended rear clearance to noncombustible surfaces 50 mm (2").

NOTE: The minimum thickness of solid noncombustible materials is specified in section 2 of Document 'J', in relation to the clearance of the appliance from the surface. As a general rule, the thickness of solid non-combustible material forming the recess of a fireplace is a minimum of 200 mm.

Minimum rear clearance from combustible walls (e.g. timber framed or studded walls) 890 mm (35") measured from the rear edge of the stove top. (Fig. 11, B)

Minimum side clearance from combustible walls 610 mm (24") measured from the side edge of the stove top. (Fig. 11, A)

Minimum distance from stove to movable combustible materials (e.g. furniture, drying clothes, etc.) 1220 mm (48").

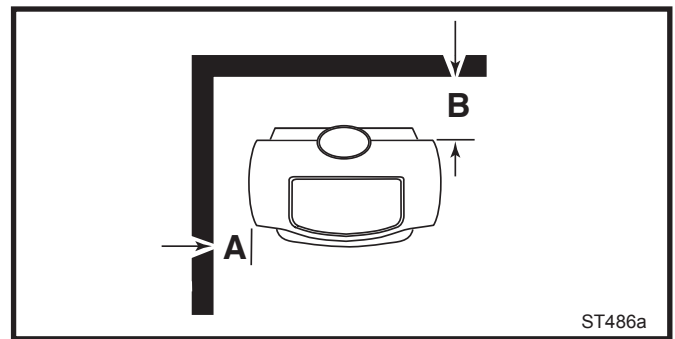

Fig. 11 Minimum clearances.

Connecting Flue Pipe - Clearances

Single wall connecting fluepipes can reach extremely high temperatures; therefore, clearances from the connecting fluepipe (chimney connector) must comply with the requirements of Part J of Building Regulations 2000 (Combustion Appliances and Fuel Storage Systems). This can be achieved by following the recommendations of Approved Document 'J'. These are as shown in Figure 12.

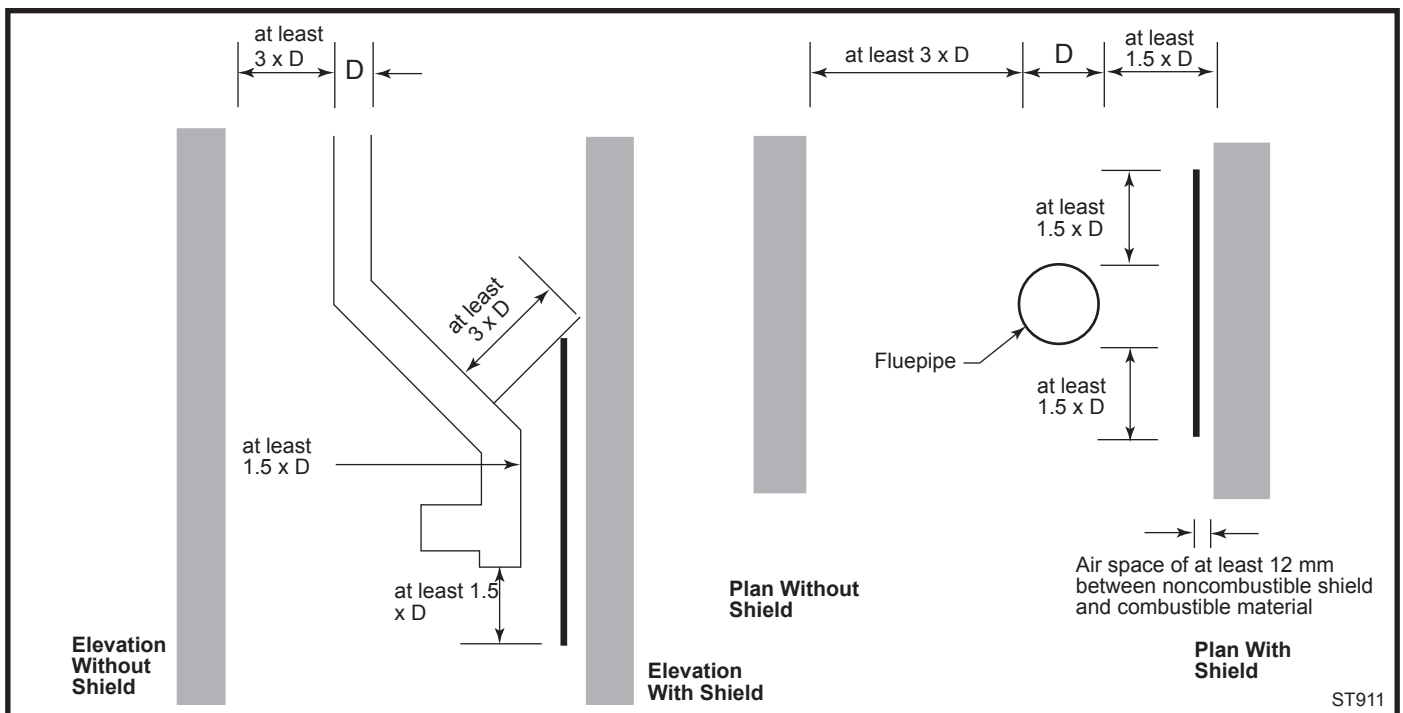

Fig. 12 Connecting fluepipe clearances.

Assembly

Set Up Your Stove

Cast iron stoves are heavy, and it will take two to four people to move your Defiant into position.

Wipe the protective coating of oil from the griddle with a clean dry rag or a paper towel.

Install the handle on the griddle. Slip the bolt through a washer, a nylon bushing, then through the handle and the other bushing, then through the steel spacer and into the griddle tab. (Fig. 17) Tighten securely.

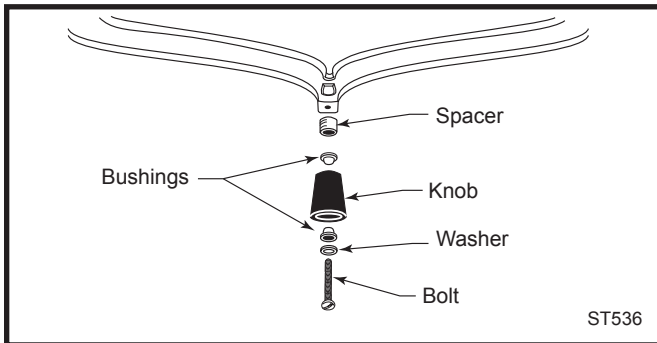

Fig. 17 Attach the griddle handle.

Install Stove Legs

The stove is shipped with the legs attached. In some instances, the legs may have been removed. Follow these instructions to reattach the legs. Install the stove legs (Fig. 21) using the hex head bolts from the parts bag. Use 3/8" washers with all four legs; the door handle holder installs on the right front leg. Position the holder so the hole to accept the handle hub faces out from the right side of the stove. Tighten the bolts firmly.

CAUTION: Overtightening can strip tapped threads.

NOTE: When moving the stove, lift the stove to take weight off the legs whenever possible. Dragging or sliding the stove, especially across rough surfaces can cause the legs to loosen or even break.

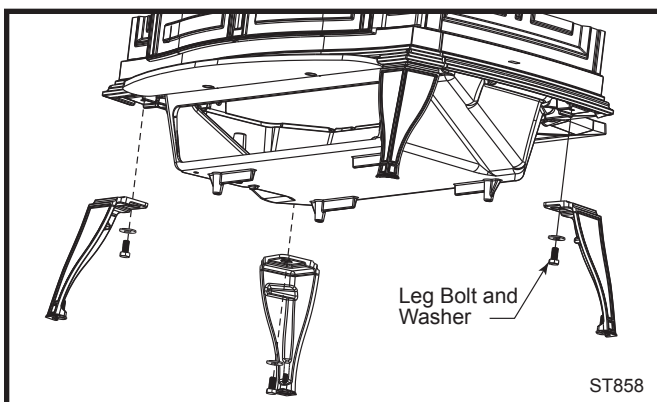

Fig. 18 Attach the stove legs.

Storing the Handle

Use the removable handle to open or close the doors. After using it, remove the handle so it will not get hot. Store the handle in the handle holder installed behind the right front leg. (Fig. 19)

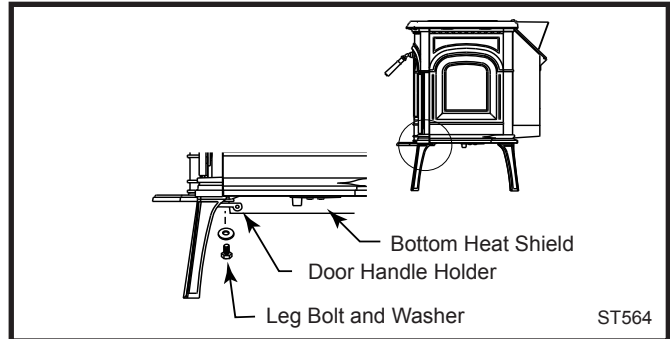

Fig. 19 Handle holder and heat shield positions.

Install the Bottom Heat Shield

NOTE: The Bottom Heat Shield is required in most installations. Refer to Floor Protection, Page 10, for further details.

1. Loosen the four 10-24 x 1/2" hex head bolts from the corners of the ash drop on the stove bottom.
3. Align the bottom heat shield holes with the four bolts. The outside air cutout hole should be toward the rear of the stove.
4. Tighten the four hex head bolts securely after passing all four bolts through the large end of the keyholes and then pulling the shield forward to engage the smaller ends of the keyhole slots. (Fig. 20)

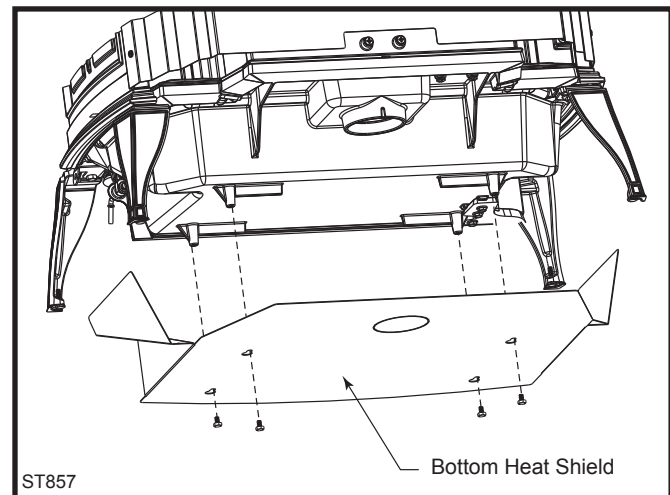

Fig. 20 Attach the optional bottom heat shield.

5. Attach the right side of the heat shield to the handle holder using a #10 1/2" phillips sheet metal screw.

Install the Optional Ash Door Heat Shield

Many installations will require the use of the supplied ash door heat shield. Refer to the "Floor Protection" sections starting on Page 9 to determine if your installation requires the use of the ash door heat shield.

1. Remove the two Phillips pan head screws from the ash door.
2. Insert the screws through the ash door heat shield (from the painted side), place the 8 mm (5/16") spacers over the screws, and carefully thread them back into the original holes. (Fig. 21) The curved lip should be upward, under the ashlip of the stove.
3. Tighten securely.

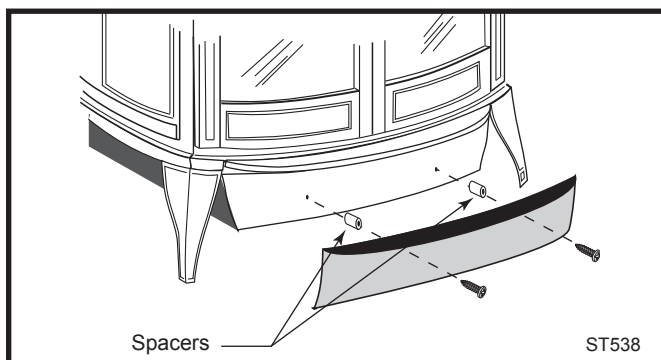

Fig. 21 Install the ashdoor heat shield.

Adjust the Leg Levellers

Lift the stove slightly so there is no weight on the leg while making the adjustment.

Reverse the Flue Collar (If necessary)

Reverse the flue collar by removing the two screws that attach it to the back of the stove. Be sure the gasket around the flue collar opening is in position when you screw the collar back onto the stove.

Attach the Damper Handle

Use the 1/4" -20 x 3" screw to attach the damper handle to the damper stub on the left side.

Attach the Primary Air Thermostat Handle

The primary air thermostat handle is the smaller of the two black handles. Secure the handle to the stub on the right side of the stove with an 8-32 x 2" slot head machine screw. (Fig. 22)

Assemble the Removable Insert Handle

The ceramic removable insert handle opens and closes the front doors. Remove after each use, and store it in the handle holder behind the right front leg. Assemble the handle by passing the 86 mm (3 3/8") screw through the ceramic shaft and into the bright metal nub. (Fig. 23) Tighten carefully until snug.

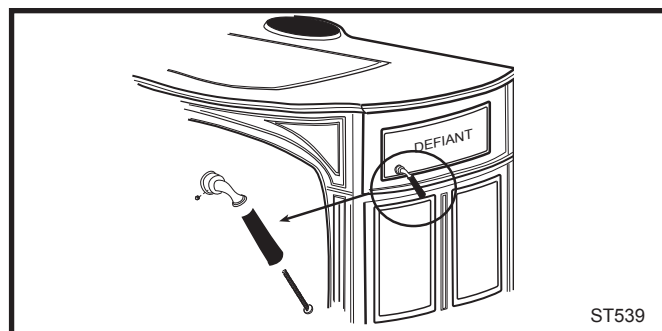

Fig. 22 Attach the thermostat handle.

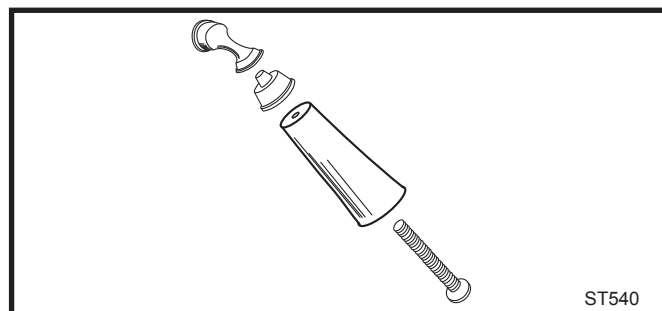

Fig. 23 Assemble the front door handle.

Fan Kit Installation

1. Attach the fan assembly at the bottom edge of the inner back with two (2) 1/4-20 x 3/4" hex head screws.
2. Attach snapstat to the mounting holes on the underside of the bottom with two (2) 1/4-20 pan head screws.
3. Attach the rheostat holder (provided with the stove) under the right front wing of the bottom heat shield with two (2) #10 sheet metal screws.
4. Attach the rheostat to its holder by inserting the rheostat control shaft through the holder hole. Install the retaining ring and rheostat knob onto the shaft.
5. Secure the rheostat cable to the underside of the bottom heat shield using the wire tie provided and the hole at the right rear edge of the heat shield.
6. Fan will not operate until stove reaches approximately 43° C (109° F).

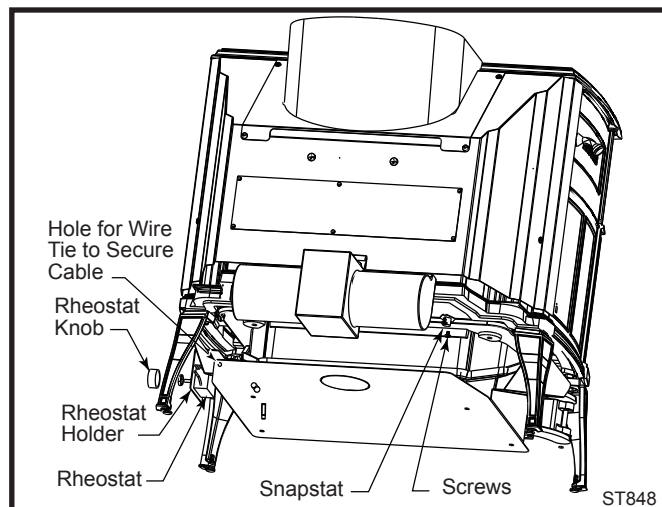

Fig. 24 Fan installation (Kit # 2767).

Operation

The Defiant Controls

Two controls regulate the performance of the Defiant: a **primary air control** supplies oxygen for the fire, and a **damper** directs air flow within the stove to activate and deactivate the catalytic combustor. (Fig. 25)

Symbols cast into the stove are reminders of the correct directions for using the controls. The words 'Left' and 'right' in these directions are *facing the stove*.

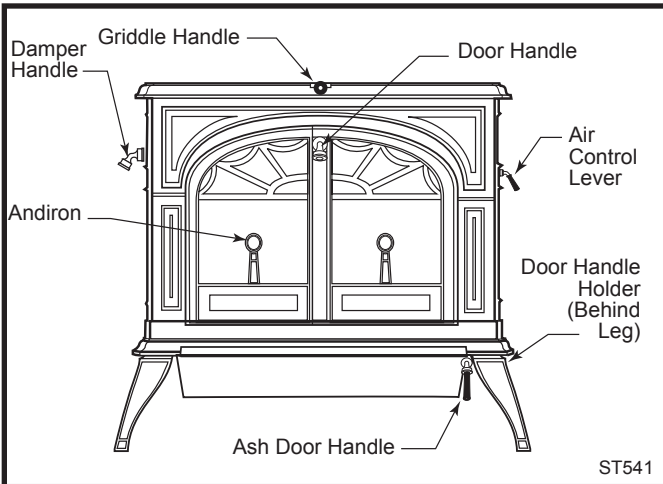

Fig. 25 The Defiant's controls are conveniently located and easy to operate.

A Single Air Control Regulates Heat Output and Burn Time

The **primary air control lever**, on the right side of the stove, controls the amount of incoming air for starting, maintaining, and reviving a fire.

More air entering the stove makes the fire burn hotter and faster, while less air prolongs the burn at a lower heat output level. (Fig. 26)

For the greatest air supply and maximum heat output (but the shortest burn time), move the lever toward the front of the stove. For a fire that will last longer with less heat, move the lever toward the rear of the stove.

A Damper Directs Air Flow Within the Stove

The **damper handle** on the left side of the stove operates the damper to direct air flow within the stove.

The damper is **open** when the handle points to the **rear**, enabling smoke to pass directly into the chimney. The damper must be open when starting or reviving a fire, and whenever the griddle or doors are opened.

The damper is **closed** when the handle points **forward**. Smoke travels through the non-catalytic combustion

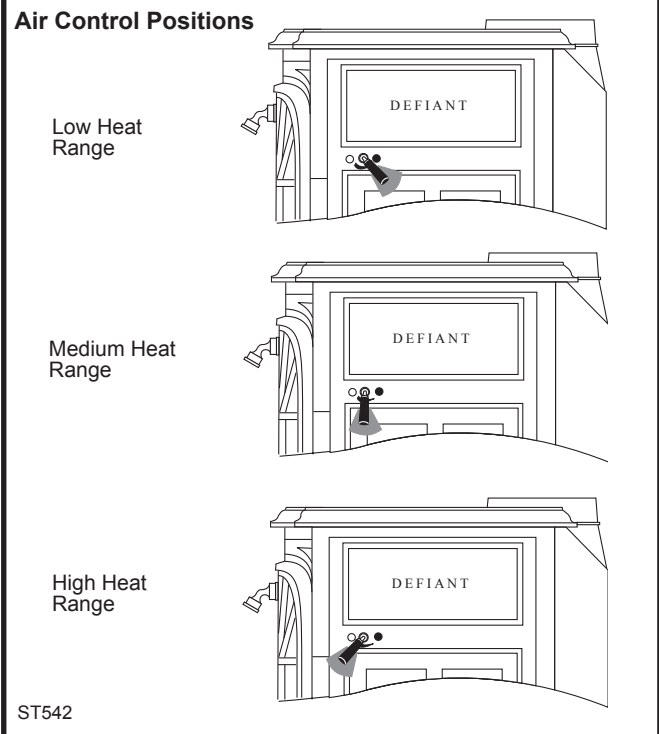

Fig. 26 The handle also may be positioned anywhere between the two extremes for different heat levels.

system where it can be further burned, before passing up the chimney. (Fig. 27)

The damper should always be either fully open or fully closed. There are no intermediate positions. When closing the damper, be sure to pull firmly enough to snap the handle into the locked position.

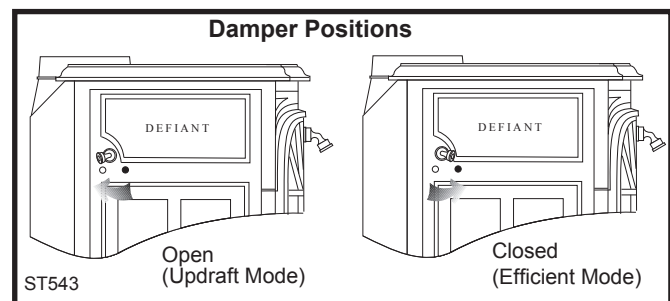

Fig. 27 The Defiant's damper operating positions.

Two Ways to Add Fuel

The Defiant's griddle lifts for convenient top-loading of logs, and is the easiest way to add fuel. (Fig. 28)

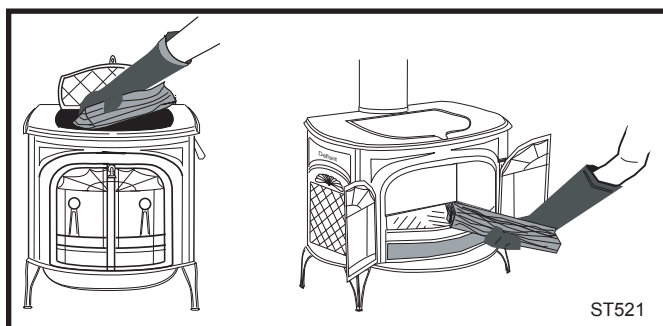

Fig. 28 Top loading is the best way to add fuel during regular use. Front loading is useful for kindling a fire.

In addition, however, the front doors open as well for adding an occasional log to a fire. **The Defiant NC is not approved for operation in Europe with the front doors open.**

To open the front doors, insert the handle into the door latch stub and turn it to the left and up. (Fig. 29)

To close them, always close the left door first. Turn the handle in the right door to the left and up (to the open position) and close it. Finally, push on the door as you turn the handle to the right and down. The doors will draw in slightly, and the handle should offer some resistance as you turn it to the closed position.

To reduce the risk of breaking the glass, avoid striking the glass or slamming the doors.

When you are not using the door handle, store it in the holder behind the right front leg of the stove. Be careful to not drop the handle, since it is breakable.

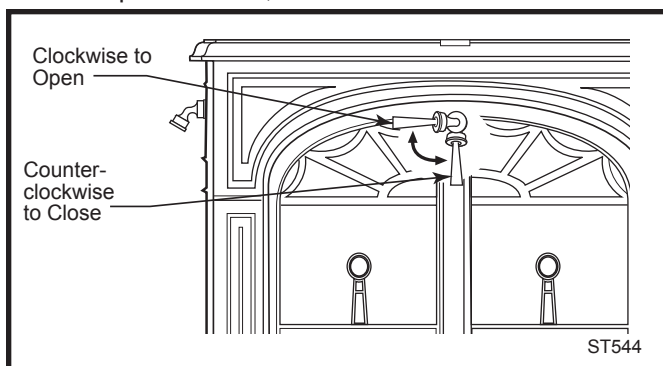

Fig. 29 To open the front doors, turn the handle clockwise.

This stove is designed to operate efficiently with the fire doors (front doors and griddle) closed. The firebox and ash doors should be kept closed at all times except when refueling or removing ashes.

Infra-Red Reflective Glass Panels for Clear Fire Viewing

The outer surfaces of the ceramic glass panels have an infrared-reflective coating which keeps the inner surfaces warm. This design, along with a pre-heated 'airwash,' makes clear fire viewing possible at most firing levels.

30003846

Andirons Help Protect the Glass

Your stove has andirons to keep logs away from the glass panels. The andirons are essential to maintain clear fire viewing, and should be left permanently in place. Since the andirons may slightly hinder refueling through the front doors, most stove owners will prefer the convenience of top loading through the griddle. Do not place fuel between the andirons and the doors.

Burn Only High-Quality Wood

The Defiant is designed to burn natural wood only; do not burn fuels other than that for which it was designed.

You'll enjoy the best results when burning wood that has been adequately air-dried. The wood should be 559-610 mm (22-24") in length. Avoid burning "green" wood that has not been properly seasoned. **Do not burn construction materials;** they often contain chemicals and metals that can damage the inside surfaces of the stove and pollute the air. Do not burn ocean driftwood; when it burns, the salt it contains will attack the cast iron.

The best hardwood fuels include oak, maple, beech, ash, and hickory that has been split, stacked, and air-dried outside under cover for at least one year.

If hardwood is not available, you can burn softwoods that include tamarack, yellow pine, white pine, Eastern red cedar, fir, and redwood. These should also be properly dried.

Store wood under cover to keep it dry. The longer it is stored, the better heating and fire-viewing performance you will enjoy. Even for short-term storage, be sure to keep wood a safe distance from the heater and keep it out of the areas around the heater used for refueling and ash removal.

A Surface Thermometer is a Valuable Guide to Operation

An optional surface thermometer tells you when to adjust the air control, and when to refuel. (Fig. 30)

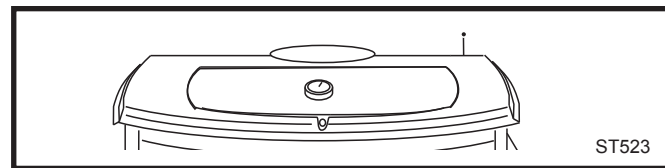

Fig. 30 Take temperature readings with a thermometer located in the middle of the griddle.

For example, when the thermometer registers at least 230° C (450° F) after start-up you know the stove is hot enough and it may be time to close the damper. Note that the stove will warm up much sooner than the chimney, though; a warm chimney is the key to easy, effective stove operation. Please review the draft man-

agement information on Page 26 to see how the size, type, and location of your chimney will affect your stove operation. When thermometer readings drop below 175° C (350° F) it is time to adjust the air control for a higher burn rate or to reload the stove. A temperature reading over 385° C (750° F) is a sign to cut back on the air supply to slow the burn rate.

Use the following temperature ranges as a guide:

- Readings in the 175°-260° C (350°-500° F) range indicate low to medium heat output.
- 260°-315° C (500°-600° F) readings indicate medium heat output.
- Readings of 315-385° C (600°-750° F) indicate high heat output. Operating your Defiant continuously at griddle temperatures of 385° C (750° F) or higher may damage the cast iron or enamel finish.

Use the Air Control Settings that Work Best for You

No single air control setting will fit every situation. Each installation will differ depending on the quality of the fuel, the amount of heat desired, and how long you wish the fire to burn; outdoor air temperature and pressure also affect draft.

The control setting also depends on your particular installation's "draft," or the force that moves air from the stove up through the chimney. Draft is affected by such things as the length, type, and location of the chimney, local geography, nearby obstructions, and other factors. See Page 27 for details on how the installation affects performance.

Too much draft may cause excessive temperatures in the Defiant, and could even damage the stove. On the other hand, too little draft can cause backpuffing into the room and/or the "plugging" of the chimney.

How do you know if your draft is excessively high or low? Symptoms of too much draft include an uncontrollable burn or a glowing-red stove part. Signs of weak draft are smoke leaking into the room through the stove or chimney connector joints or low heat output.

In some newer homes that are well-insulated and weather-tight, poor draft may result from an insufficient air supply in the house. In such instances, an open window near the stove on the windward side of the house can provide the combustion air supply needed.

Refer to Section 2 of Document J which requires an outside air vent for appliances with power outputs above 5 kW. Always refer to national and local codes to determine your specific requirements.

The Defiant NC is equipped to deliver outside air for combustion and outside air kit #3265 is available.

When first using the stove, keep track of the air control

settings. You will quickly find that a specific setting will give you a fixed amount of heat. It may take a week or two to determine the amount of heat and the length of burn you should expect from various settings.

Most installations do not require a large amount of combustion air, especially if adequate draft is available.

Do not for any reason attempt to increase the firing of your heater by altering the air control adjustment range outlined in these directions.

Use the following air control settings as a starting point to help determine the best settings for your installation. Each is described as a fraction of the total distance the lever may be moved from right to left.

Defiant Control Settings

(Refer to Figure 27, Page 19)

Burn Rate	Primary Air Control
Low	From far right to 1/3 the distance to left
Medium	From 1/3 to 2/3 the distance to left
High	From 2/3 the distance to left, to far left

DO NOT OPERATE THE STOVE WITH THE ASH DOOR OPEN. OPERATION WITH THE ASH DOOR OPEN CAN CAUSE AN OVERFIRING CONDITION TO OCCUR. OVERFIRING THE STOVE IS DANGEROUS AND CAN RESULT IN PROPERTY DAMAGE, INJURY OR LOSS OF LIFE.

Conditioning Your Stove

Cast iron is extremely strong, but it can be broken with a sharp blow from a hammer or from the thermal shock of rapid and extreme temperature change.

The cast plates expand and contract with changes in temperature. When you first begin using your Defiant, minimize thermal stress by letting the plates adjust gradually during three or four initial break-in fires following Steps 1-3 below.

Starting and Maintaining a Wood Fire

Burn only solid wood in the Defiant, and burn it directly on the grate. Do not elevate the fuel. Do not burn coal or other fuels.

The bypass damper must be open when starting a fire or when refueling.

Do not use chemicals or fluids to start the fire. Do not burn garbage. Never use flammable fluids such as gasoline, gasoline type lantern fuel, kerosene, charcoal lighter fluid, naphtha, engine oil or similar liquids to start or "freshen up" a fire in this heater. Keep all such liquids well away from the heater while it is in use.

1. Open the stove bypass damper, and open the primary air control fully.
2. Place several sheets of crumpled newspaper in the stove. Place six or eight pieces of dry kindling split to a finger-width size on the paper. On the kindling, lay two or three larger sticks of split dry wood approximately 25-51 mm (1-2") in diameter. (Fig. 31)

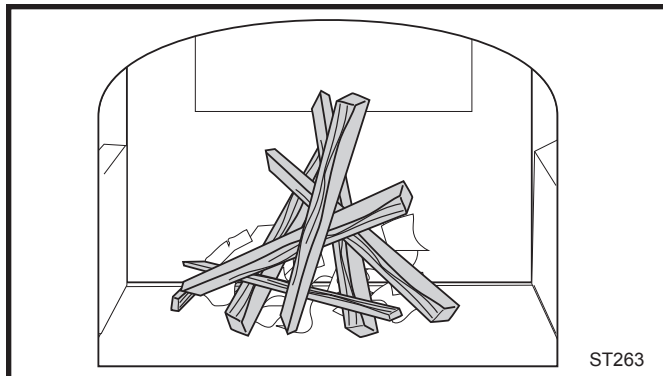

Fig. 31 Start the fire with newspaper and dry kindling.

3. Light the newspaper and close the door. Gradually build up the fire by adding a few 76-127 mm (3-5") diameter pieces of split firewood. **If this is one of the first few "break-in" fires, let the fire burn brightly, and then let it die out.**

During the break-in fires, do not let the stove get hotter than 260° C (500° F) as measured on an optional stove-top thermometer. Adjust the air control lever as necessary to control the fire.

Some odor from the stove's hot metal and the paint is normal for the first few fires.

NOTE: Some chimneys must be "primed," or warmed up, before they will draw sufficiently to start a fire. To correct this situation, roll up a couple pieces of newspaper, place them on top of the kindling and toward the back of the stove, light them, and close the doors. This will encourage the smoke to rise rapidly, making it easier to establish a good draft.

Once the draft is established, open the front door and light the rest of the fuel from the bottom. Do not light the main bed of fuel until the chimney begins drawing, and repeat the procedure as often as necessary if the initial attempt is unsuccessful.

4. If your Defiant has been broken-in previously using Steps 1-3, continue to build the fire gradually. Add larger wood with a diameter of 76-102 mm (3-4"). Continue adding split logs of this size to the briskly-burning fire until there is a glowing ember bed 51-76 mm (2-3") deep. (Fig. 32) A good ember bed is necessary for proper functioning of the non-catalytic system and may take an hour or more to establish.

5. Close the damper when the griddle temperature reaches 230° C (450° F).

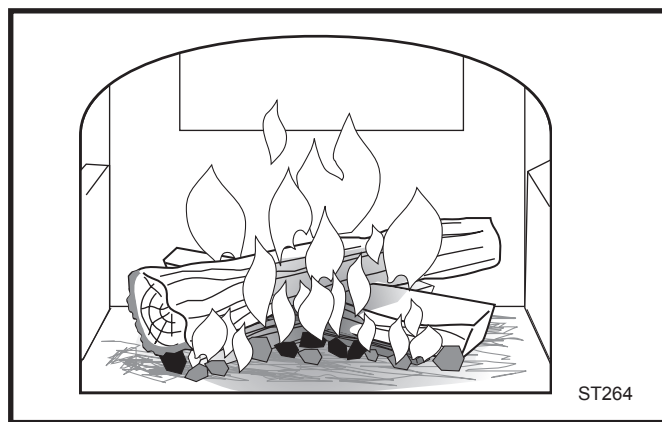

Fig. 32 Add larger pieces of wood as the fire begins to burn well.

6. Adjust the air control for your desired heat output.

NOTE: Stove installations vary widely, and the operating guidance given here is only a starting point. The draft management information on Page 27 will explain in detail how the features of your installation may help or hinder good draft, and how you may need to vary your firing technique if your installation doesn't encourage a good draft.

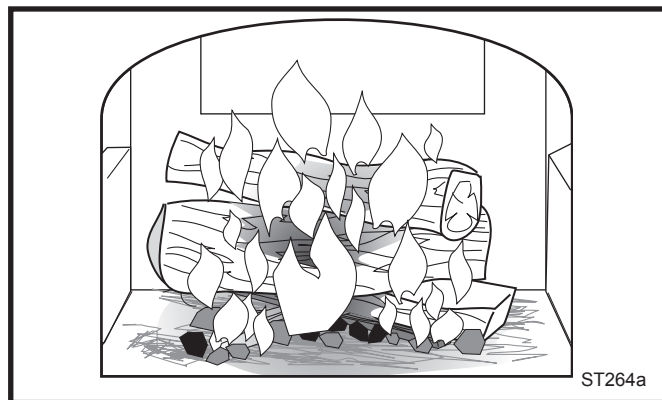

Fig. 33 Add full size logs after the ember bed is 3" (75mm) deep.

Refuel While the Embers Are Still Hot

When reloading, best results will be achieved if you first de-ash the stove by stirring the fuel bed to allow ash to fall through the grate into the ash pan.

Do not break the charcoal into very small pieces or pound or compress the charcoal bed.

It is important that air can circulate through the charcoal bed during the burn. Larger pieces of charcoal allow more air to circulate under the wood, resulting in the fire reviving more quickly.

For best results when refueling, wear long-cuffed stove gloves to protect your hands and forearms, add fuel while the stove still has plenty of glowing embers to re-ignite the fire, and include some smaller pieces of wood in the new fuel load to help the stove regain its

operating temperature quickly. Use this sequence as a guide to successful refueling:

NOTE: Door handles can be hot. A glove has been included with your stove. We recommend using this glove whenever operating door or damper controls and especially when operating the top griddle.

1. Open the damper.
2. De-ash the stove as described above. Open the ashdoor and check the level of ash in the ash pan. Empty the pan if necessary and replace it in the stove. Close the ash door.
3. Open the griddle, load the wood (smaller pieces first), and close the griddle.
4. Close the damper.
5. When the surface temperature reaches 230° C (450° F), adjust the air control for the amount of heat you desire.

NOTE: If the remaining charcoal bed is relatively thick (51-76 mm/2-3") and if your fuel is well seasoned, it is possible to add fresh fuel (smaller pieces first), close the door and damper, and reset the primary air control for the desired heat output within five minutes.

CAUTION: The Defiant will be hot while in operation. Keep children, clothing and furniture away. Contact may cause skin burns.

DO NOT OVERFIRE THIS HEATER. Overfiring may cause a house fire, or can result in permanent damage to the stove. If any part of the Defiant glows, you are overfiring.

Ash Disposal

Routine ash removal is important for ease of maintenance, and is important for the stove's durability. Remove ash before it reaches the top of the ash pan. Check the level at least once a day. Every few days, clear any ash from the outer edges of the firebox. Most of the ash will fall through the grate. Slice or stir the ash with a shovel or poker so that it falls through the grate slots.

IMPORTANT: Check the level of ash in the ash pan before reloading the stove. If the ash level is close to the top edge of the pan, empty the pan according to this procedure:

- Open the damper.
- Open the griddle or front doors, and use a shovel or poker to stir excess ash through the ash slots in the grate down into the ash pan.
- Close the griddle or doors, and unlatch the ash door. (Fig. 34) It will pivot, swinging the ash pan out of the stove.
- Slide the cover onto the pan, making sure it is securely closed. (Fig. 35)
- Remove the ash pan, making sure to keep it level.
- To keep the cover from sliding off and to keep ash from falling on the floor, do not tilt the ash pan forward.

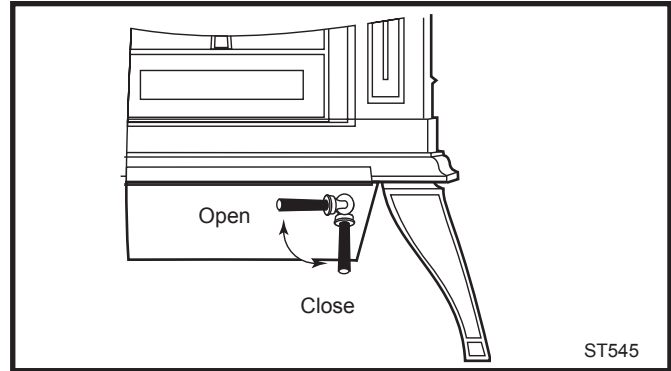

Fig. 34 Turn the ashdoor handle clockwise to open and counterclockwise to close.

- If the stove is in operation, close the ash door while disposing of the ash. You may need to lift the latch end of the door slightly to align the latch with the mating part on the stove bottom.
- Properly dispose of the ash in a metal container with a tight-fitting lid. Store the container outdoors away from all combustible material.
- Return the ash pan to its original position in the stove, and close and latch the ash door. (Fig. 35)
- Do not operate the stove with the ash door open. This will result in over-firing, and could cause damage to the stove, void the warranty, or even lead to a house fire.

Empty the ash pan regularly, typically every one to three days. The frequency will vary depending on how you operate your Defiant: ash will accumulate faster at higher heat outputs.

Remove ash frequently and place it outdoors in a metal container with a tight-fitting lid. Place the closed container of ash on a noncombustible floor or on the ground, well away from all combustible materials, pending final disposal. If the ash is disposed of by burial in soil or otherwise locally dispersed, it should be kept in the closed container until all cinders have thoroughly cooled.

You can use wood ash as a garden fertilizer.

CAUTION: Never use your household or shop vacuum cleaner to remove ash from the stove; always remove and dispose of the ash properly.

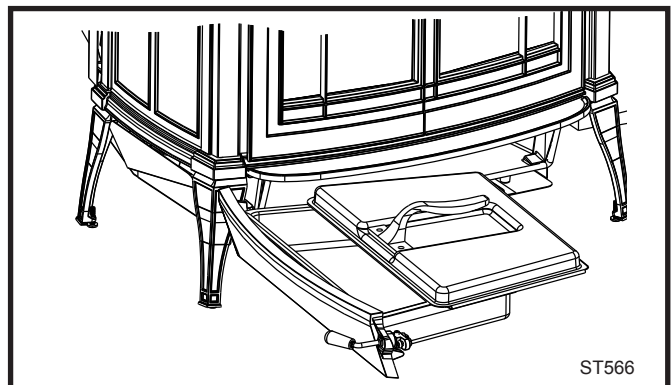

Fig. 35 Be sure the cover is securely attached before removing the ash pan.

Draft Management

A stove is part of a system, which includes the chimney, the operator, the fuel, and the home. The other parts of the system will affect how well the stove works. When there is a good match between all the parts, the system works well.

Wood stove or insert operation depends on natural (unforced) draft. Natural draft occurs when the exhaust is hotter (and therefore lighter) than the outdoor air at the top of the chimney. The bigger the temperature difference, the stronger the draft. As the hot gases rise through the chimney they provide suction or 'draw' that pulls air into the stove for combustion. A slow, lazy fire with the stove's air inlets fully open indicates a weak draft. A brisk fire, supported only by air entering the stove through the normal inlets, indicates a good draft. The stove's air inlets are passive; they regulate how much air can enter the stove, but they don't move air into it.

Depending on the features of your installation - steel or masonry chimney, inside or outside the house, matched to the stove's outlet or oversized - your system may warm up quickly, or it may take a while to warm up and operate well. With an 'airtight' stove, one which restricts the amount of air getting into the firebox, the chimney must keep the stove's exhaust warm all the way to the outdoors in order for the stove to work well. Some chimneys do this better than others. Here's a list of features and their effects.

Masonry Chimney

Masonry is a traditional material for chimneys, but it can perform poorly when it serves an 'airtight' stove. Masonry is a very effective 'heat sink' - it absorbs a lot of heat. It can cool the chimney gases enough to diminish draft. The bigger the chimney, the longer it takes to warm up. It's often very difficult to warm up an outdoor masonry chimney, especially an oversized one, and keep it warm enough to maintain an adequate draft.

Steel Chimney

Most factory-made steel chimneys have a layer of insulation around the inner flue. This insulation keeps the chimney warm. The insulation is less dense than masonry, so a steel chimney warms up more quickly than a masonry chimney. Steel doesn't have the good looks of masonry, but it performs much better.

Indoor/Outdoor Location

Because the chimney must keep the smoke warm, it's best to locate it inside the house. This uses the house as insulation for the flue and allows some heat release

into the home. An indoor chimney won't lose its heat to the outdoors, so it takes less heat from the stove to heat it up and keep it warm.

Chimney Height

The common wisdom tells us that a taller flue draws better than a short one. This isn't necessarily so. If a chimney is tall enough to meet the safety requirements of the 2/3/10 foot rule, then adding more height isn't the right answer to a draft problem. In fact it could make the problem worse by adding more mass to the chimney system, which must be warmed up, a distance from the heat source (the stove). Don't make a chimney taller unless you must in order to meet the safety rules, or unless there's some nearby feature causing a downdraft. Even then, there are downdraft-preventing chimney caps available, which are probably the smarter choice.

Flue Sizing

The inside size of a chimney for an 'airtight' stove should match the size of the stove's flue outlet. When a chimney serves an airtight stove, more is not better; in fact, it can be a disadvantage. Hot gases lose heat faster as they travel slower through a chimney; if we vent a stove with a 152mm (6") flue collar [181 sq cm (28 sq in area) into a 254 x 254 mm (10 x 10") flue, the gases slow to one third their original speed. This allows the gases to cool more rapidly, which weakens draft strength. If an oversized flue is also outside the house, the heat it absorbs gets transferred to the outdoor air and the flue usually stays cool.

It is common for a masonry flue, especially one serving a fireplace, to be oversized for the stove. It can take quite a while to warm up such a flue, and the results can be disappointing. The best solution to an oversized flue is an insulated steel chimney liner, the same diameter as the stove or insert's flue outlet; the liner keeps the exhaust warm, and the result is a stronger draft. An uninsulated liner is a second choice - the liner keeps the exhaust restricted to its original size, but the hot gases still must warm up the air around the liner. This makes the warm-up process take longer.

Pipe & Chimney Layout

Every turn the exhaust must take as it travels to the chimney top will slow it down. The ideal pipe and chimney layout is to vent vertically into a completely straight and vertical chimney. If you are starting from scratch, use this layout if possible. If the stovepipe must elbow to enter a chimney, locate the thimble about midway between the stove top and the ceiling. This achieves several goals: it allows the gases to speed up before

they must turn, it leaves some pipe in the room for heat transfer, and it gives you long-term flexibility for installing a different stove without relocating the thimble. There should be no more than eight feet of single-wall stove pipe between the stove and a chimney; longer runs can cool the exhaust enough to cause draft and creosote problems. With prefabricated chimney, bring it down to six to eight feet from the stove. With a masonry chimney, arrange the pipe so that it turns into the chimney within eight feet of the stove.

Single Venting

Each 'airtight' stove requires its own flue. If an airtight stove is vented to a flue that also serves an open fireplace, or a leakier stove, it's easier for the chimney draft to pull air in through those channels and performance of the stove suffers. Imagine a vacuum cleaner with a hole in the hose to understand the effect here. In some cases the other appliance can even cause a negative draft through the stove, and result in a dangerous draft reversal.

Creosote

Creosote is a by-product of slow wood-burning. It's an organic tar that can condense in the flue if it is present in the exhaust, slow-moving, and cools to less than 290°F (130°C). Condensed creosote is volatile, and can generate chimney fires if it gets hot enough. All the features that affect chimney draft also affect creosote condensation - so use whatever combination of installation features and operational steps that will encourage good draft and minimize creosote production.

Because letting the exhaust cool off and slow down is one of the keys to creosote accumulation, it makes sense to line a chimney to match the stove's outlet size, for safety reasons as well as performance. Consult a qualified installer and check local and national codes for recommended chimney sizing.

Fuel

Even the best stove installation will not perform well with poor fuel. The best fuel is hardwood that has air-dried 12-18 months. Softwood burns, but not as long as hardwood. 'Green' wood has a lot of moisture in it; it will burn, but some of the heat potential is used to boil the extra moisture from the wood. This reduces the amount of heat that reaches your home and can contribute to a creosote problem. There are moisture meters available for firewood; you can also judge your wood by its appearance and weight. If you get it green, lift a piece and get a sense of its weight; it can lose a third or more of its weight as it dries. Also look at the ends of a log; as it dries it shrinks and often cracks. The more weathered and cracked a piece is, the drier it is.

Dry wood burns readily with a good chimney draft. But with modern stoves, wood can be too dry and too volatile. Smoke and combustible gases can 'gas out' from the wood quickly and densely enough to overload the combustion system. If you hear a rumbling or roaring noise (like a

propane torch) from the stove, that is a sign that the stove is overfiring.

Back-puffing

Back-puffing results when the fire produces volatile gases faster than the chimney draft pulls them out of the firebox. The gases back up in the firebox until they are concentrated enough and hot enough to ignite. If your stove back-puffs, the stove needs to cool down. You should open the damper to let the smoke rise to the flue more quickly, allow more air into the firebox, avoid big loads of firewood and check that the wood moisture is not too low.

Draft Testing

An easy way to test your chimney draft is to close the stove's damper, wait a few minutes to let the airflow stabilize, then see whether you can vary the strength of the fire by swinging the air control open and closed. Results are not always instant; you may need to wait a few minutes for a change in the air control setting to have an effect on the fire. If there's no change, then the draft isn't strong enough yet to let you close the damper, and you'll need to open it for awhile longer and manage the fire with the air inlet until the draft strengthens. If you keep track of your burning habits and relate them to their effects on the stove's operation, you'll be rewarded with good performance and a safe system.

Negative Pressure

Good draft also depends on a supply of air to the stove; a chimney can't pull in more air than is available to it. Sluggish draft results when a house is tight enough to prevent the ready flow of air to the stove, or by competition between the stove and other equipment that sends indoor air outside - especially power-driven equipment like range hoods, clothes dryers, etc. If the chimney draws well with all other equipment turned off (or sealed, in the case of fireplaces and/or other stoves), then you simply need to be careful with timing the use of the other air consuming equipment. If you need to crack a nearby window or door to enable the chimney to flow well, it may be a good idea to install an outside-air intake to bring combustion air directly to the stove. An outside air kit is available to connect the stove directly to a source of outdoor combustion air.

In many cases, local or national codes require the installation of permanently open air vents, particularly with larger appliances (i.e. above 5 kW). Refer to these codes to determine specific requirements for your installation.

Conclusion

Wood-burning is an art rather than a science. Once the stove and chimney system are in place, you can only vary your technique, mostly your timing, to achieve good results. If you keep track of your burning habits and relate them to their effects on the stove's operation, you'll be rewarded with good performance and year of reliable heating.

Maintenance

Below you will find important information on general care, inspection and maintenance of your Vermont Castings stove. Should it become necessary, use only replacement parts recommended by your authorized dealer.

Keep Your Stove Looking New and Working Its Best

Let the fire in the stove go out and allow the stove to cool completely before beginning any maintenance procedure.

Care of the Cast Iron Surface

An occasional dusting with a dry rag will keep the painted cast iron of your Defiant looking new.

The stove's paint can be touched up as needed. First, mask the areas, such as enamelled parts, glass, or handles, around the spot to be painted. Clean the spot with a wire brush. Remove the griddle and set it aside. It is normal for the griddle to darken after use. You can clean it with a fine-bristle wire brush, or steel wool.

Then, touch up the stove with Vermont Castings' high temperature stove paint. Apply the paint sparingly; two light coats of paint are better than a single heavy one.

Care of the Porcelain Enamel Surface

Use a dry or slightly damp rag or soft brush to remove spills or stains. For difficult jobs that require a cleaning agent, use only a kitchen appliance cleaner or polish recommended for use on enamel surfaces.

Cleaning the Glass

Most of the carbon deposits on the glass will burn off during hot fires.

However, the ash residue that accumulates on the glass surface should be removed regularly to prevent etching. To clean the glass, follow this procedure:

- Be sure the glass is completely cool.
- Clean the glass with water or a cleaner made especially for this purpose. Do not use abrasive cleaners. Use cleaning agents sparingly and be sure to keep them off the outer surfaces of the stove.
- Rinse the glass thoroughly.
- Dry the glass completely.

Replace Broken Glass Immediately

Do not operate your stove if the glass in the doors is damaged.

If you need to replace the glass, use only the high temperature ceramic glass supplied by Vermont Cast-

ings. Do not use substitutes. Be sure to specify left or right glass; the panels are not interchangeable, due to a heat-reflective coating on the side toward the room.

Removing the Glass

1. Remove the right and left door assemblies by raising the door until the lower hinge pin clears its hole; then, angle the door bottom slightly outward and pull down to release the upper hinge pin. Place the doors face down on a padded work surface. Be especially careful with enamelled doors.
2. Remove the screws that hold the glass retainer clips in place, and remove the clips.
3. Carefully lift the broken glass panel from the door.

Installing the Glass

Check the gasket around the window; it should be soft and resilient so that the glass will seal properly against the door. Replace the gasket if it has hardened or if it is compressed.

1. Center the glass on the gasket. Be sure to place the glass so that the infrared reflective coating is on the exterior side, facing toward the room.
2. Secure the glass on both doors with the retainer clips. Tighten all screws. (Fig. 36)
3. Replace the doors on the stove.
4. Open and close the doors to check that they fit and work properly. Adjust as necessary.

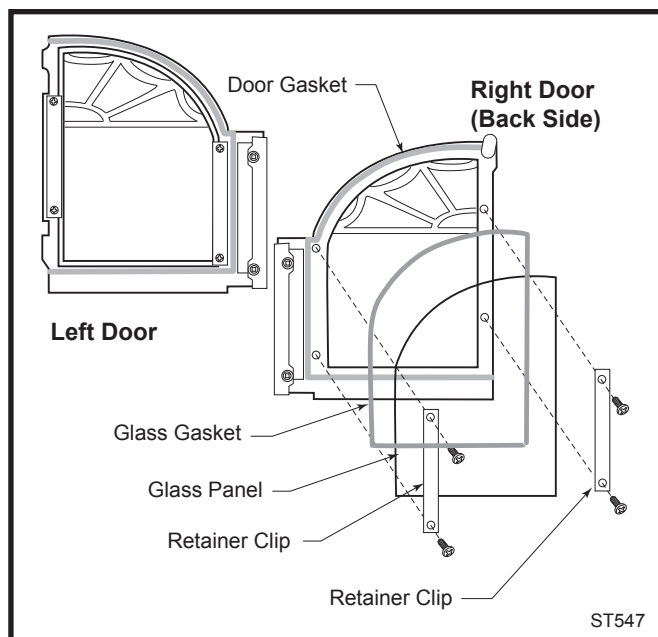

Fig. 36 An exploded view of the glass assembly.

Adjust the Damper as Needed

The tension on the Defiant's damper is adjustable to compensate for compression of the gasket that seals the damper to the upper fireback. To adjust the damper:

1. Remove the griddle. Loosen the lock nut at the center of the damper. (Fig. 37)
2. Turn the pressure screw approximately one half turn clockwise with an Allen wrench provided with your stove.
3. Tighten the lock nut. Prevent the pressure screw from turning as you tighten the nut. Re-test the damper.

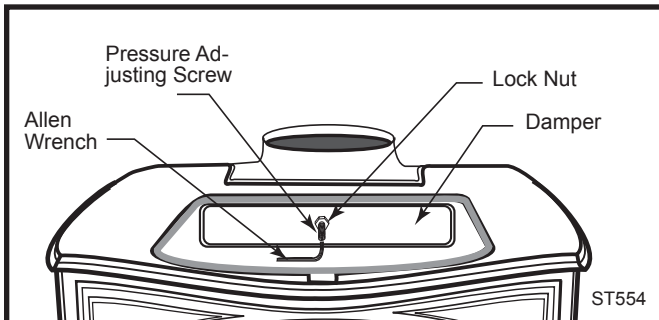

Fig. 37 Adjust the damper with the Allen wrench.

Tighten the Damper Handle as Needed

A handle on the left side of the stove controls the damper. The handle attaches to the damper rod with a set screw. Periodically check the set screw and tighten as necessary.

How to Adjust the Door Latches

The Defiant's doors should close securely to prevent accidental opening and to keep air from leaking into the stove. On properly adjusted doors, the handles should resist slightly as they are turned to the closed position and the doors themselves should be drawn slightly toward the stove.

Over time, the gasket around the doors will compress and the latches may need adjustment.

To adjust the latches, loosen the small lock nut, rotate the striker screw a half-turn, and re-tighten the small lock nut. (Fig. 40) Your stove kit includes an Allen wrench for latch adjustments. Hold the striker screw to keep it from turning as you tighten the lock nut. Make repeated small adjustments until the setting is right.

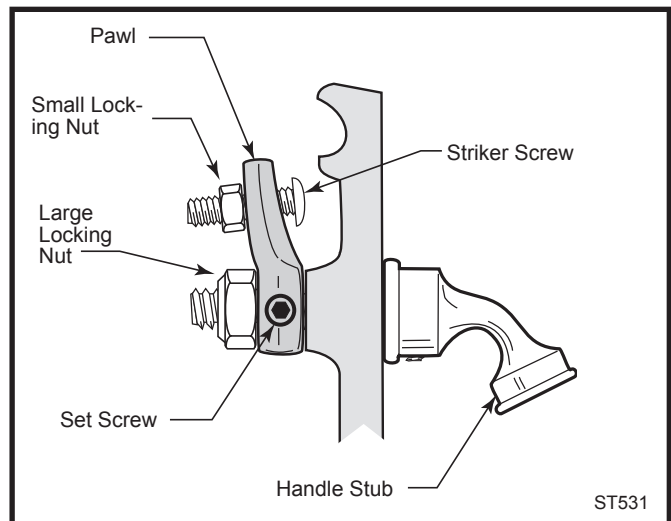

Fig. 38 Turn the door latch striker screw in or out to tighten or loosen the screw.

Replace the Stove Gaskets as Needed

Your Defiant uses fiberglass rope gaskets to make a tight seal between some parts. With use, particularly on moving parts, gaskets can become brittle and compressed and can begin to lose their effectiveness. These will need periodic replacement.

The sizes of replaceable gasket are listed below, along with their applications.

Gasket Diameter... ..And the Parts it Seals

- | | |
|-------|--|
| 5/16" | The griddle to the stove top (wire reinforced gasket) |
| 5/16" | The damper to the upper fireback; the front doors to the stove front; and the doors to each other. |
| 3/8" | The ash door to the front of the bottom panel |
| 3/16" | The outer glass panes to the door |

If you need to change a gasket, first obtain an appropriate replacement from your Vermont Castings, Authorized Dealer.

Wait until the fire is out and the stove has cooled. Be sure to follow the standard safety procedure for working with dusty materials: wear safety goggles and a dust mask.

The procedure for replacing gaskets is the same, regardless of the gasket location. Follow these eight steps:

1. Remove the existing gasket by grasping an end and pulling firmly. (Fig. 39)
2. Use a wire brush or the tip of a screwdriver to clean the channel of any remaining cement or bits of gasket. Remove stubborn deposits of cement with a cold chisel if necessary. (Fig. 39)

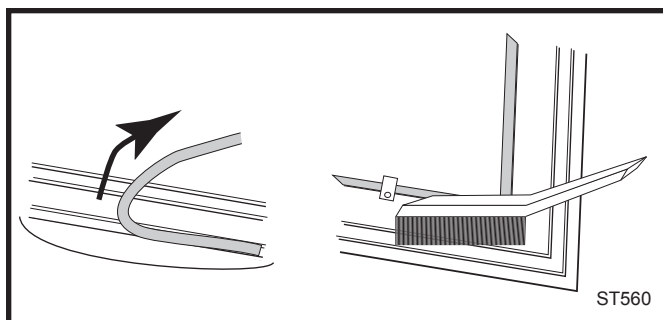

Fig. 39 Remove gasket then clean channel with wire brush.

3. Determine the correct length of the appropriate-sized gasket by laying it out in the channel. Allow an extra 25-51 mm (1-2"), and mark the spot to be cut.

4. Remove the gasket from the channel, place it on a wood cutting surface, and cut it at the marked spot with a utility knife.

Twist the ends slightly to keep the gasket from unraveling.

5. Lay an unbroken 3 mm (1/8") bead of gasket cement in the newly-cleaned channel. (Fig. 40)

6. Starting at one end, press the gasket into the channel. (Fig. 48) Ensure a good joint where the gasket meets before trimming any excess. Do not overlap the gasket ends or leave ends with ragged edges.

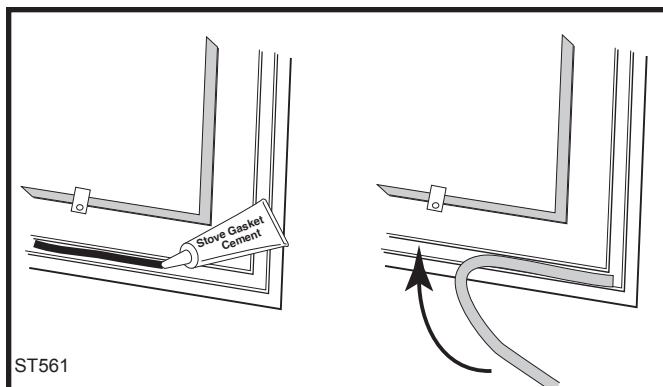

Fig. 40 Lay a bead of gasket cement then press gasket in place.

7. Press the gasketed part firmly against its normal mating surface to seat the gasket evenly in its channel. Close and latch the door to do this, or tap other parts with the rubber mallet (or hammer/block of wood).

8. Clean any excess cement from around the channel, then let the cement that holds the new gasket dry thoroughly.

9. The stove's doors may need adjustment after you have regasketed them. Initially, it may require loosening the latch to accommodate the new gasket; after a few weeks, it may need tightening to compensate for compression of the new gasket. The directions for adjusting the latches are on Page 30.

All Gasketed Construction Gaskets

Other gaskets form seals between all other non-moving parts, but these are not subject to the same wear and deterioration as gaskets on moving parts. It is unlikely that you will ever need to replace these gaskets unless the involved parts are disassembled and then put back together. If this is the case, the job should be done only by a qualified service technician.

5/16" diameter gasket seals the following parts:

- The lower fireback to the back panel
- The left and right air plates (inner sides)
- All connections between the stove plates.

The Chimney System

Creosote

Your Defiant is designed to reduce creosote build-up significantly. However, regular chimney inspection and maintenance must still be performed. For safety, good stove performance, and to protect your chimney and chimney connector, inspect your chimney and chimney connector on a regular schedule. Clean the system if necessary. Failure to keep the chimney and connector system clean can result in a serious chimney fire.

When wood is burned slowly, it produces tar, organic vapors and moisture that combine to form creosote. The creosote vapors condense in the relatively cool chimney flue of a slow-burning fire. As a result, creosote residue accumulates on the flue lining. When ignited, this creosote makes an extremely hot fire within the flue system that can damage the chimney and overheat adjacent combustible material. If a significant layer of creosote has accumulated — 1/8" (3 mm) or more — it should be removed to reduce the risk of a chimney fire.

You can never be too safe. Contact your local fire authority for information on what to do in the event of a chimney fire, and have a clearly understood plan on how to handle one.

If you do experience a chimney fire, act promptly to:

- Close the damper and air control lever.
- Get everyone out of the house.
- Call the Fire Department.

Inspect the system every two weeks during the heating season as part of a regular maintenance schedule. To inspect the chimney, let the stove cool completely. Then, using a mirror and a strong light, sight up through the flue collar into the chimney flue. If you cannot inspect the flue system in this fashion, the stove must be disconnected to provide better viewing access.

Clean the chimney using a brush the same size and shape as the flue liner. Flexible fiberglass rods are used to run the brush up and down the liner, causing any deposits to fall to the bottom of the chimney where they can be removed through the clean-out door.

Clean the chimney connector by disconnecting the sections, taking them outside, and removing any deposits with a stiff wire brush. Reinstall the connector sections after cleaning, being sure to secure the joints between individual sections with sheet metal screws.

If you cannot inspect or clean the chimney yourself, contact your local Vermont Castings dealer or a professional chimney sweep.

Maintenance Schedule

The stove and chimney system should be inspected and maintained by a qualified engineer and include the following:

The Stove

DAILY:

- Clear any ash build-up from around the air holes and combustion flow path in the lower fireback.
- Ashes should be removed before they reach the top of the ash pan. Check accumulation at least once a day.
- Keep the area around the stove clear of any combustible materials such as wood, furniture or clothing.

TWO MONTHS:

- Check door handle to be sure it is working properly. Gasketing becomes compressed after a period of time. Adjust handle tightness if necessary.
- Check leg bolts and heat shield screws; tighten if necessary.

ANNUAL SPRING CLEANING:

- Check gasketing for wear, and replace if necessary.
- Remove ashes from the ash pan and replace with a moisture absorbing material (such as kitty litter) to keep the interior of the stove dry.
- Clean the dust from the inner sides of bottom, rear or pipe heat shields if your stove is equipped with them. Clean surfaces are better heat reflectors than dirty surfaces.
- Touch up the black paint.
- Inspect for and remove ash build-up behind the combustion package. This should be done in conjunction with annual cleaning of the chimney connector since this inspection is most conveniently done through the flue collar opening. Inspect the passages to either side of the combustion package (a mirror will be

helpful) and vacuum away ash using a flexible vacuum hose inserted into each passage. Care should be taken not to damage the white fibrous material in this rear chamber. (Fig. 41)

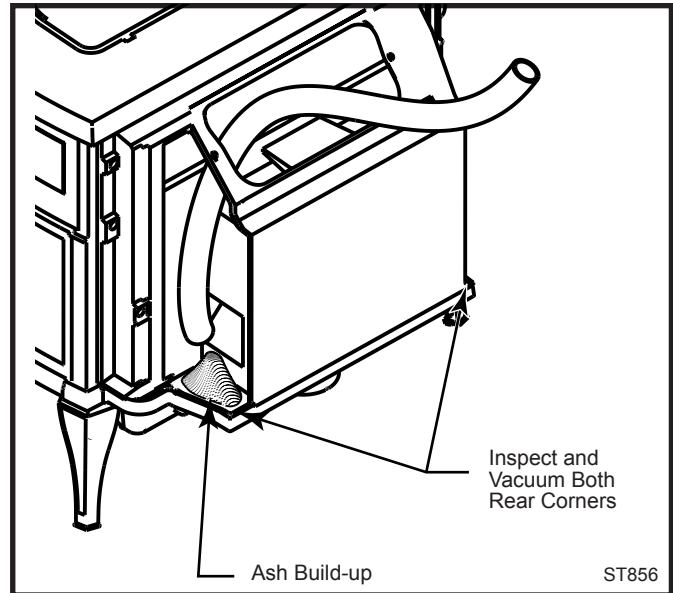

Fig. 41 Inspect and clean out ash accumulation on either side of the non-catalytic combustion system.

The Chimney Connector

TWO WEEKS:

- Inspect the chimney connector and chimney. Clean if necessary.

TWO MONTHS:

- Inspect the chimney and chimney connector. Pay particular attention to the horizontal runs of chimney connector, and the elbows. Clean the system if necessary.

ANNUAL SPRING CLEANING:

- Disassemble the chimney connector and take it outdoors for inspection and cleaning. Replace weak sections of connector.
- Inspect the chimney for signs of deterioration. Repairs to a masonry chimney should be made by a professional mason. Replace damaged sections of prefabricated chimney. Your local Dutchwest dealer or a chimney sweep can help determine when replacement is necessary.
- Thoroughly clean the chimney.

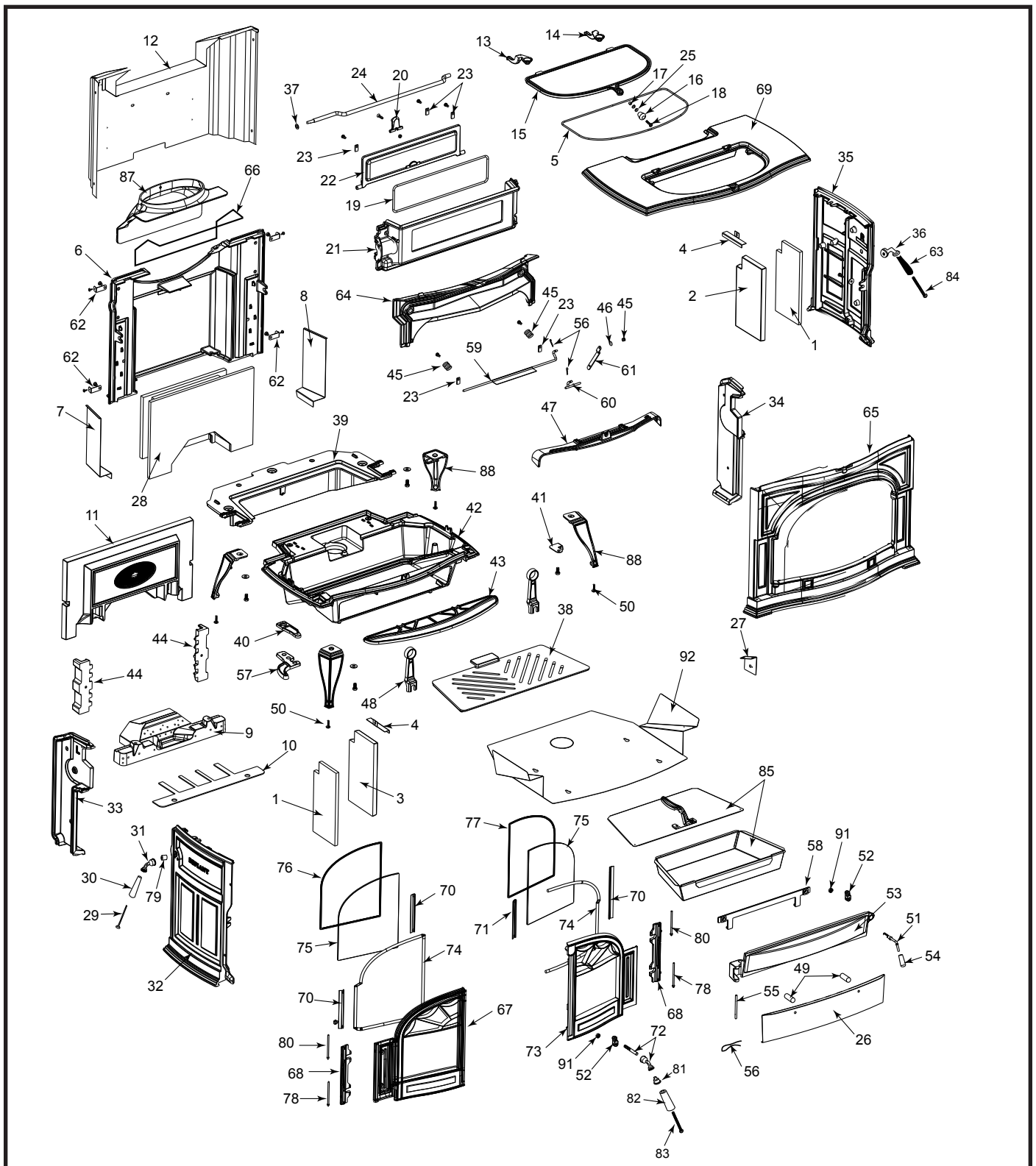

CFM Corporation reserves the right to make changes in design, materials, specifications, prices and discontinue colors and products at any time, without notice.

Defiant Woodburning Stove

Model 1610CE

30003846

25

Defiant Woodburning Stove Model 1610CE (continued)

Item Description	Part Number
1. Side Insulation	30002846
2. Right Side Brick	30002847
3. Left Side Refractory	30002848
4. Brick Support Bracket	30002480
5. Griddle Gasket	1203668
6. Back	30002833
7. Left Heat Deflector	30002442
8. Right Heat Deflector	30002441
9. Shoe Refractory	30002243
10. Shoe Gasket	30002864
11. Fireback	30002840
12. Outer Back	30002839
13. Left Griddle Quadrant	30002399
14. Right Griddle Quadrant	30002401
15. Griddle	30002822
16. Griddle Handle	1600657
17. Griddle Handle Spacer	1600070
18. Griddle Handle Bolt	1200907
19. Damper Gasket	1203588
20. Damper Ramp	1300643
21. Damper Housing	30002821
22. Damper ¹	30002816
23. Damper Tab ¹	1601488
24. Damper Rod ¹	1600065
25. Griddle Handle Bushing	1201895
26. Ash Door Heat Shield	1401911
27. Rheostat Bracket	30002863
28. Fountain Assembly	30002100
29. Damper Handle Screw	1201310
30. Damper Handle	1600644
31. Damper Handle Base Assy	30002720
32. Left Side	See Chart Pg. 37
33. Left Air Manifold	30002818
34. Right Air Manifold	30002817
35. Right Side	See Chart Pg. 37
36. Thermostat Handle Base Assy	30002716
37. Washer Damper Rod	1202560
38. Grate	30002820
39. Inner Bottom	30002838
40. Top Ashdoor Hinge	30002836
41. Door Handle Bracket	30002844
42. Bottom	30002829
43. Ashlip	See Chart Pg. 37
44. Fireback Retainer	30002815
45. Friction Spring	1201846
46. Washer Friction Spring/Therm Handle Linkage	1202471
47. Air Plate	30002819
48. Andiron	30002827
49. Control Spacer	1201781
50. Leg Leveller	1201745
51. Ashdoor Handle Shaft	1600622

Item Description	Part Number
52. Door Latch Assy	5004025
53. Ashdoor	30002810
54. Ashdoor Handle (Wood)	1600663
55. Ashdoor Hinge Rod	30002826
56. Cotter Pin, Ashdoor	30001749
57. Ashdoor Bottom Hinge Support	1300642
58. Ashpan Bracket	30001908
59. Primary Air Flap	30002849
60. Primary Air Shaft	30002841
61. Air Linkage	30002842
62. Rear Side Bracket	30002845
63. Thermostat Handle	1600660
64. Airwash Manifold	30002814
65. Front	See Chart Pg. 37
66. Flue Collar Gasket	30001910
67. Left Door	See Chart Pg. 37
68. Door Hinge Strip	1300645
69. Top	See Chart Pg. 37
70. Glass Clip	30001715
71. Glass Clip (Right Door Only)	30001716
72. Front Door Handle & Shaft	30002717
73. Right Door	See Chart Pg. 37
74. Door Gasket	1203589
75. Glass Gasket	1203556
76. Left Door Glass ¹	1600064
77. Right Door Glass ¹	1600062
78. Lower Door Hinge Pin	30002727
79. Spacer (for Damper rod)	1201779
80. Upper Door Hinge Pin	30002727
81. Handle Base Stub ²	30002714
82. Ceramic Handle ²	20006381
83. Handle Bolt ²	1201294
84. Thermostat Handle Bolt	1201243
85. Ash Pan Assy	30001690
87. Flue Collar	See Chart Pg. 37
88. Leg	See Chart Pg. 37
91. Hex Head Jam Nut	1203290
92. Bottom Heat Shield	30002843

NOTES:

In this diagram and throughout this manual, 'left' and 'right' mean as you face the stove.

When ordering parts, be sure to mention the stove's model number. When ordering external parts, be sure to specify color.

1. Not interchangeable, due to a heat-reflective coating on the room side of the glass.
2. Included in #0004345 Black Ceramic Handle Assy.

The hardware in the Defiant is in standard sizes; most bolts are 1/4" diameter by 20 threads per inch. Most hardware stores can supply replacement hardware if you specify bolt diameter, number of threads per inch and length. Fasteners inside the firebox should be replaced with stainless steel for ease of future disassembly.

Defiant Woodburning Stove Model 1610CE (continued)

Shell Enamel Parts - Defiant Model 1610CE							
Part Name	Classic	Biscuit	Bordeaux	Chestnut Brown	Ebony	Midnight Blue	Vermont Green
Top	30002834	30002874	30002915	30002926	30002894	30002884	30002937
Left Side	30002832	30002872	30002913	30002924	30002892	30002882	30002935
Right Side	30002831	30002871	30002912	30002923	30002891	30002881	30002934
Flue Collar	30001576	30002947	30002921	30002932	30002910	30001617	30002943
Front	30002830	30002873	30002914	30002925	30002893	30002883	30002936
Ashlip	30002811	30002870	30002911	30002922	30002890	30002880	30002933
Left Door Sub Assy	30002854	30002879	30002920	30002931	30002899	30002889	30002942
Left Door	30002813	30002876	30002917	30002928	30002896	30002886	30002939
Right Door Sub Assy	30002853	30002878	30002919	30002930	30002898	30002888	30002941
Right Door	30002812	30002875	30002916	30002927	30002895	30002885	30002938
Leg	30002835	30002877	30002918	30002929	30002897	30002887	30002940

LIMITED LIFETIME Warranty

For Vermont Castings Defiant, Non-Catalytic Wood Stove

Limited Lifetime Warranty

CFM Corporation warrants that all refractory brick and material used in this product will be warranted against deterioration not resulting from physical damage or overloading of the woodstove for the lifetime of this product. This coverage includes the components of the EverBurn System: "shoe, fountain, and fireback. Coverage is provided only to the original purchaser.

Limited 3 Year Warranty

All cast iron parts are warranted for a period of three years against breakage, cracking or burn-through.

Limited 1 Year Warranty

The following part of the woodburning stove are warranted to be free of defects in material and workmanship for a period of one year from the date you receive it: The handles, glass door panels, door gasketing and porcelain finish. Any of these items found to be defective will be repaired or replaced at no charge, upon the return of the part with postage prepaid to a Vermont Castings Authorized Dealer.

Any parts repaired or replaced during the limited warranty period will be warranted under the terms of the limited warranty for a period not to exceed the remaining term of the original limited warranty or six (6) months, whichever is longer.

Exclusions & Limitations

1. This warranty is non-transferable.
2. This warranty does not cover misuse of the stove. Misuse includes overfiring, which will result if the stove is used in such a manner as to cause one or more of the plates to glow red. Overfiring can be identified later by warped plates and areas where the paint pigments has burned off. Overfiring in enamel stoves is identified by bubbling, cracking, chipping and discoloration of the porcelain enamel finish. CFM Corporation offers no warranty on chipping of enamel surfaces. Inspect your woodburning stove prior to accepting it for any damage to the enamel.
3. This warranty does not cover misuse of the stove as described in the Owners Guide, nor does it cover a stove which has been modified unless authorized by a CFM Corporation representative in writing. This warranty does not cover damage to the stove caused by burning salt saturated wood, chemically treated wood, or any fuel not recommended in the Owners Guide.
4. This warranty does not cover a stove repaired by someone other than a Vermont Castings Authorized Dealer.

5. Damage to the unit while in transit is not covered by this warranty but is subject to a claim against the common carrier. Contact Vermont Castings Authorized Dealer from whom you purchased your stove or CFM Corporation if the purchase was direct. (Do not operate the stove as this may negate the ability to process the claim with the carrier).
6. Claims are not valid where the installation does not conform to local building and fire codes or, in their absence, to the recommendations in our Owners Guide.
7. The salt air environment of coastal areas, or a high-humidity environment, can be corrosive to the porcelain enamel finish. These conditions can cause rusting of the cast iron beneath the porcelain enamel finish, which will cause the porcelain enamel finish to flake off. This warranty does not cover damage caused by a salt air or high-humidity environment.
8. CFM Corporation shall have no obligation to enhance or update any unit once manufactured.

IN NO EVENT SHALL CFM Corporation BE LIABLE FOR INCIDENTAL AND CONSEQUENTIAL DAMAGES. ALL IMPLIED WARRANTIES, INCLUDING THE IMPLIED WARRANTIES OF MERCHANTABILITY AND FITNESS, ARE LIMITED TO THE DURATION OF THIS WRITTEN WARRANTY. THIS WARRANTY SUPERCEDES ALL OTHER ORAL OR WRITTEN WARRANTIES.

Some states do not allow the exclusion or limitations of incidental and consequential damages or limitations on how long an implied warranty lasts, so the above limitations may not apply to you. This warranty gives you specific rights and you may have other rights, which vary from state to state.

How to Obtain Service

If a defect is noted within the warranty period, the customer should contact a Vermont Castings Authorized Dealer or CFM Corporation if the purchase was direct with the following information:

1. Name, address, and telephone number of the purchaser
2. Date of Purchase.
3. Serial number from the label on the back
4. Nature of the defect or damage.
5. Any relevant information or circumstances, e.g., installation, mode of operation when defect was noted.

A warranty claim will then start in process. CFM Corporation reserves the right to withhold final approval of a warranty claim pending a visual inspection of the defect by authorized representatives.

CFM Corporation

2695 Meadowvale Blvd. • Mississauga, Ontario, Canada L5N 8A3
800-668-5323 • www.cfmcorp.com

Free Manuals Download Website

<http://myh66.com>

<http://usermanuals.us>

<http://www.somanuals.com>

<http://www.4manuals.cc>

<http://www.manual-lib.com>

<http://www.404manual.com>

<http://www.luxmanual.com>

<http://aubethermostatmanual.com>

Golf course search by state

<http://golfingnear.com>

Email search by domain

<http://emailbydomain.com>

Auto manuals search

<http://auto.somanuals.com>

TV manuals search

<http://tv.somanuals.com>