

A man with short brown hair and a focused expression is shown from the chest up, wearing a blue tank top. He is holding a black handle of a gym machine, likely a lat pulldown or similar exercise. The background is a blurred gym setting with metallic poles. The image is framed by a large yellow diagonal shape on the right side.

*Assembly &
Owner's Guide*

VISION  FITNESS®

ST780
ADJUSTABLE BENCH

Table of Contents

ASSEMBLY GUIDE

ASSEMBLY GUIDE	4
HARDWARE BAGS	6
STEP 1: ORANGE BAG	8
STEP 2: BLUE BAG	9
STEP 3: PINK BAG	10

OWNER'S GUIDE

STRETCHING	12
MAINTENANCE SCHEDULE	14
COMMERCIAL WARRANTY	15
WORKOUT LOGS	16

Assembly & Owner's Guide

ST780 ADJUSTABLE BENCH

To avoid possible damage to this Adjustable Bench, please follow these assembly steps in the correct order. Before proceeding, find your new Adjustable Bench serial number located on the backrest support tube (AT1), and enter here:

Refer to this number when calling for service, and enter this serial number on your Warranty Card and in your own records. Be sure to read your Assembly/Owner's Guide before using your new Adjustable Bench.

If any parts, hardware or tools are missing, please call 1.800.335.4348, Extension 12

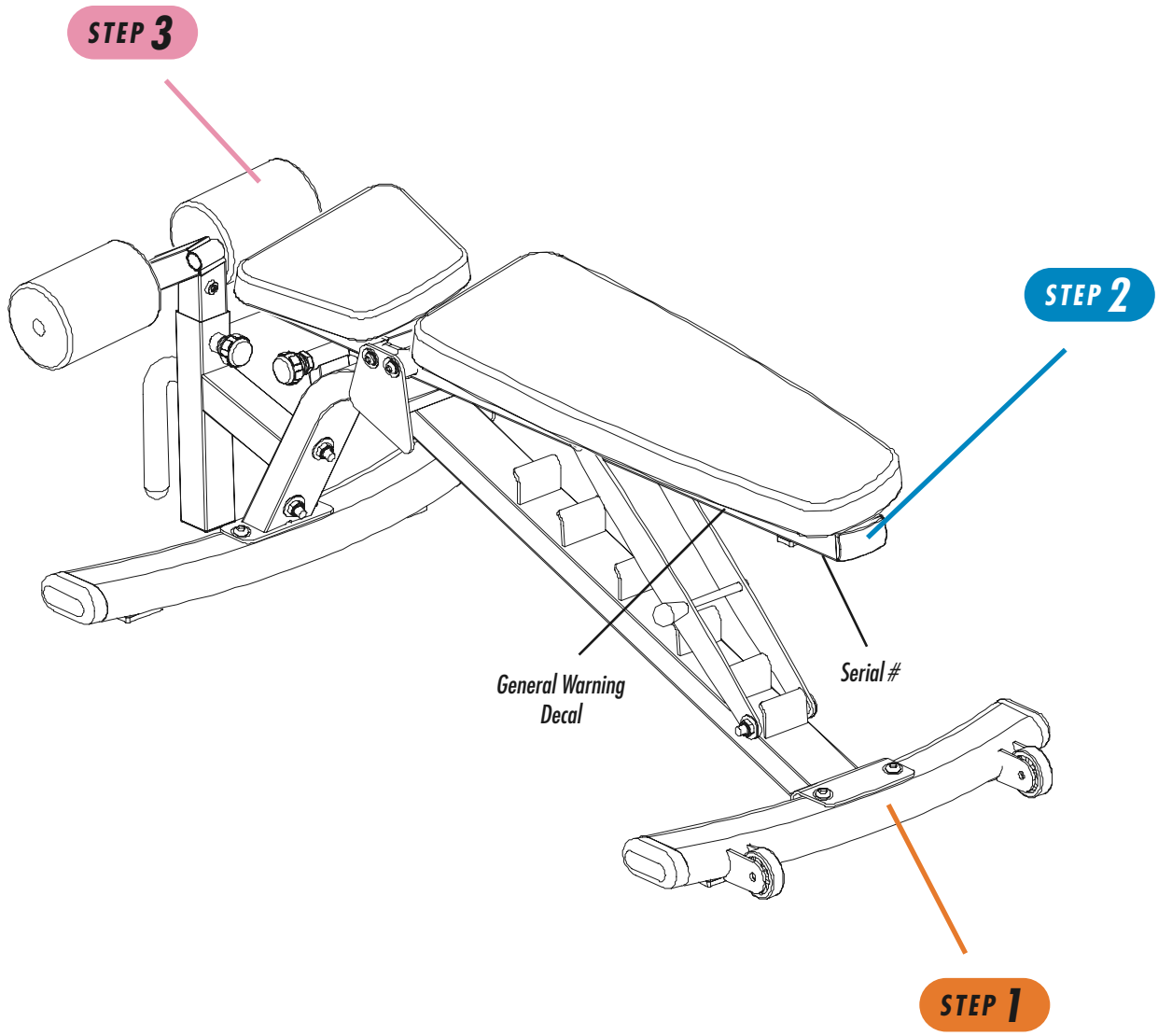

HARDWARE INCLUDED

ORANGE BAG

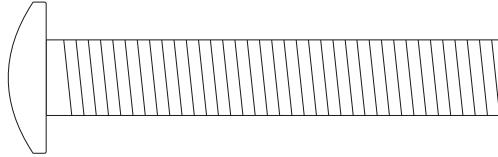
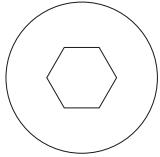

M10 x 60 Bolt
Quantity: 2

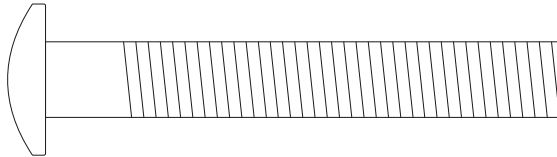
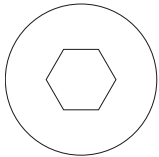

M10 x 68 Bolt
Quantity: 2

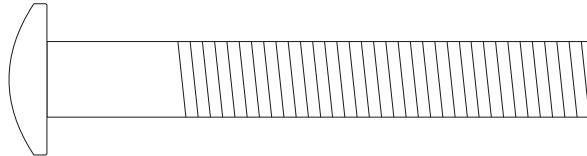
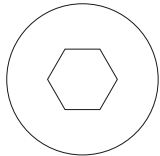

M10 x 72 Bolt
Quantity: 2

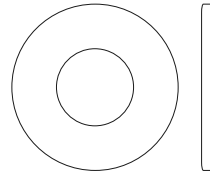

10.2 x 22 x 2
Flat Washer
Quantity: 8

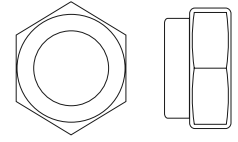

M10 Nylon Nut
Quantity: 4

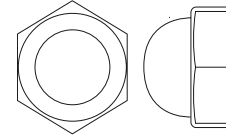

M10 Acorn Nut
Quantity: 2

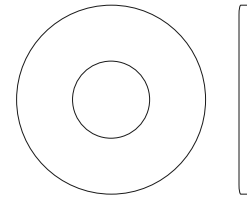

10.2 x 25 x 2
Flat Washer
Quantity: 4

HARDWARE INCLUDED

BLUE BAG

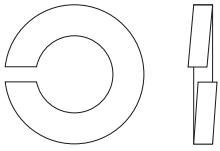

10.2 x 18.4 x 2.5
Lock Washer
Quantity: 4

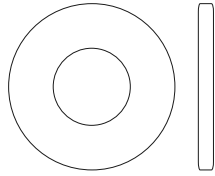

10.2 x 22 x 2
Flat Washer
Quantity: 4

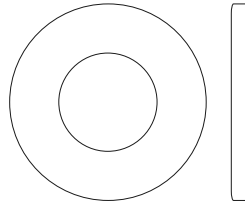

13 x 26 x 2.5
Flat Washer
Quantity: 2

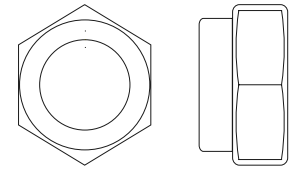

M12 Nylon Nut
Quantity: 1

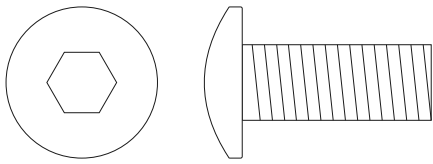

M10 x 25 Bolt
Quantity: 4

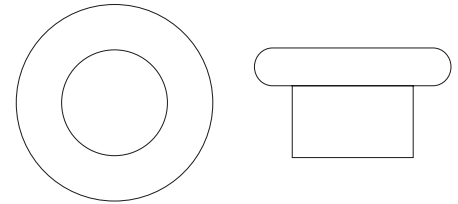

T10 Bushing
illustration not to scale
Quantity: 2

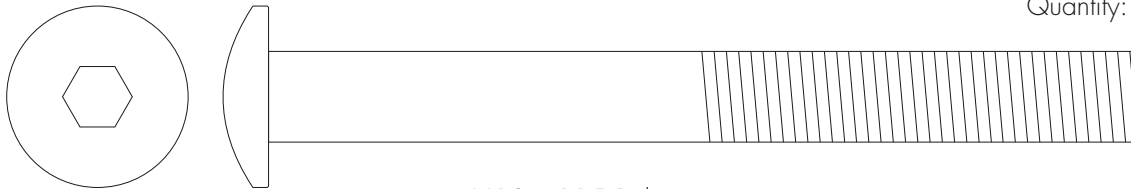

M12 x 115 Bolt
Quantity: 1

PINK BAG

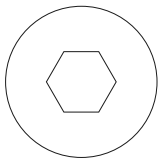

M10 x 60 Bolt
Quantity: 4

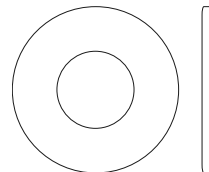

10.2 x 22 x 2
Flat Washer
Quantity: 4

STEP 1**ORANGE BAG**

- Place the rear base support (AC1) on the floor with rubber pads on the bottom. Slide the U-bracket of the main frame tube (AB1) around the rear base support. The wheels should be facing outward. Secure this joint by securing two bolts (M10x72) and two flat washers (10.2x25x2) through the bracket and base support from the bottom. Finish by adding two flat washers (10.2x25x2) and two acorn nuts (M10) to the top and tighten.

- Place the front base tube (AC2) on the floor, rubber pads on the bottom. Make sure it is oriented identical to the rear support. Position the front end of the main frame tube over the holes in the base support. Insert two bolts (M10x68) and two flat washers (10.2x22x2) from the top. Attach and tighten two flat washers (10.2x22x2) and two nuts (M10) to the bottom.

- Place the accessory receiver tube (AH1) against the face of the main frame tube (AB1). Insert two bolts (M10x60), two flat washers (10.2x22x2) and fasten two flat washers (10.2x22x2) and two nuts (M10) to the rear and tighten.

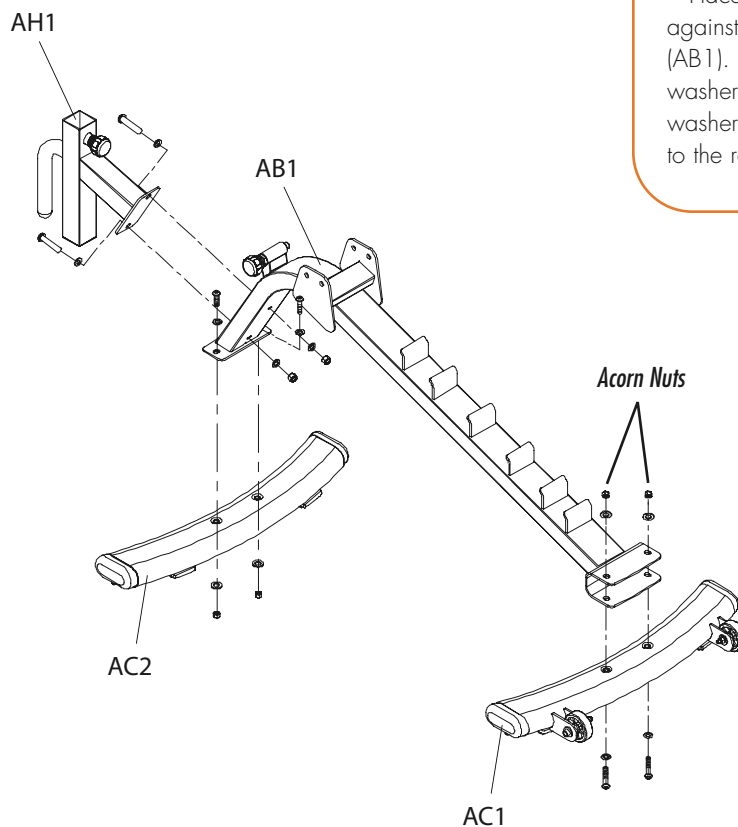

- Place the backrest support tube (AT1) into the bracket on the top of the main frame (AB1). The rubber bumper should be facing down. Line up the holes in the tube with the back set of holes in the bracket. Slide a lock washer (10.2x18.4x2.5) and a flat washer (10.2x22x2) onto a bolt (M10x25) and fasten to the left and right side of the back holes. Repeat this process, attaching the seat support tube (AT2) to the main frame's (AB1) front set of holes. After attaching, retract the pull pin and position it in one of the holes in the seat support tube (AT2).

- Place a bushing (T10) into the left and right side holes of the backrest support (AT1). Slide a bolt (M12x115) and a flat washer (13x26x2.5) thru both holes of the seatback angle adjuster (AT3) and the backrest support tube. The adjuster's handle should be positioned on the right side of the bench when looking from the front. Attach a flat washer (13x26x2.5) and a nut (M12) to the end. Do not overtighten. The seatback angle adjuster should move freely when transitioning the backrest.

- Slide the accessory tube (AH2) into the accessory receiver tube (AH1), with the vertical holes to the rear. Disengage the pull pin first, then slide the accessory tube in and engage the pin in one of the vertical holes.

- Tighten all hardware.

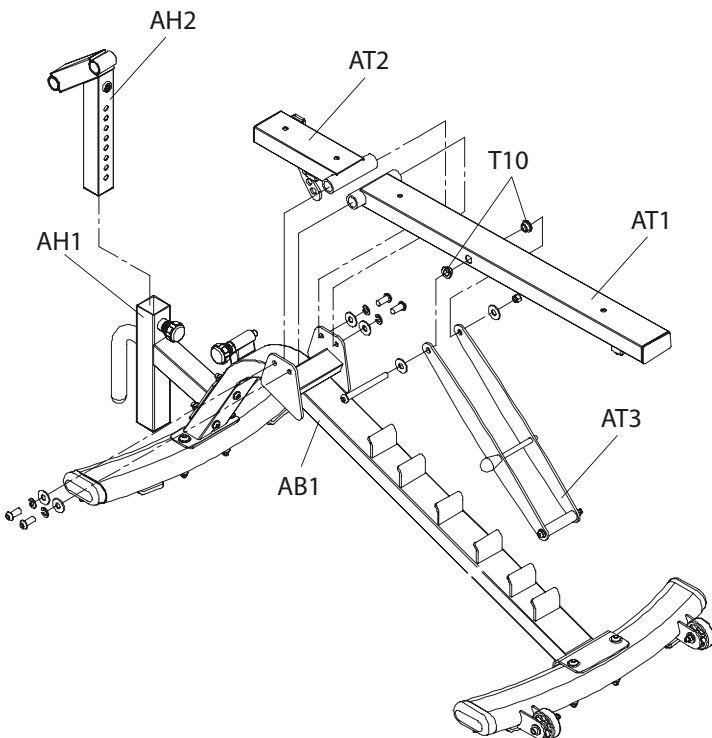

STEP 3

PINK BAG

- Line up the holes in the bottom of the backrest (J02) with the holes in the support tube (AT2). Insert a bolt (M10x60) and a flat washer (10.2x22x2) up through the bottom of the tube and tighten.
- Line up the holes in the bottom of the seat (J01) with the holes in the support tube (AT1). Insert a bolt (M10x60) and a flat washer (10.2x22x2) up through the bottom of the tube and tighten.
- Slide the roller pad rod (H06) thru either the lower hole (used for performing exercises such as abdominal crunches and decline chest movements) or the upper hole (used for holding the body down when performing exercises such as the lat pulldown) of the accessory tube (AH2). Make sure the rod is centered, before sliding a roller pad (H13) on each end.

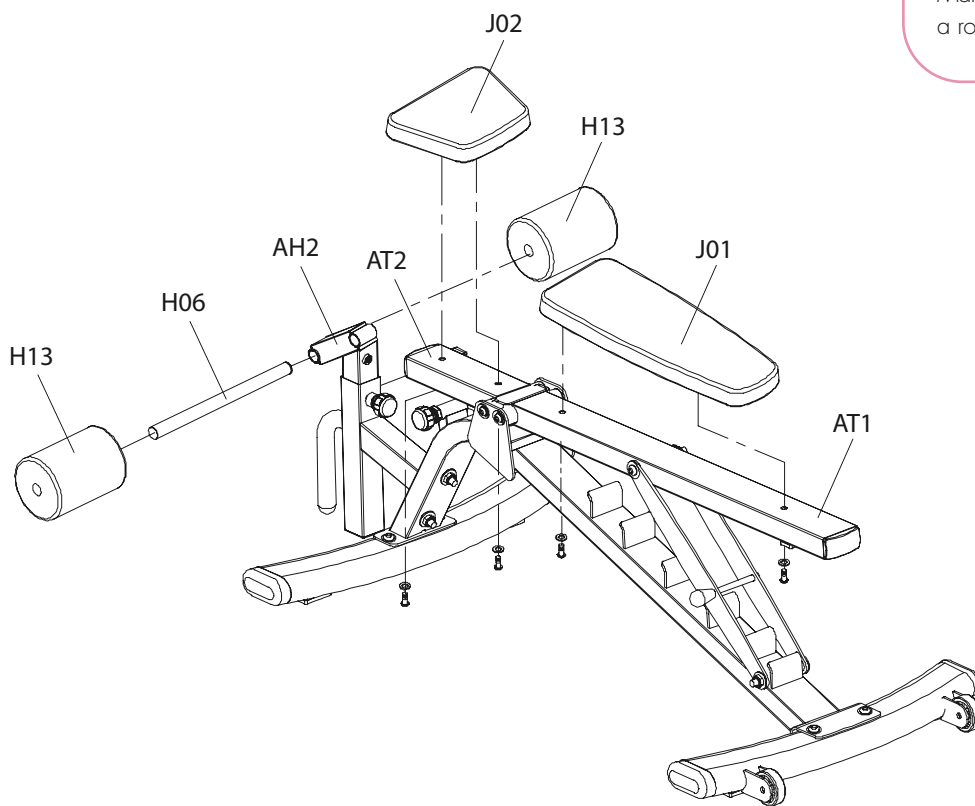

STRETCHING

Flexibility Training is not associated with fitness as often as cardiovascular exercise or Strength Training, even though it is just as important. A good stretching program will help to maintain flexibility of the hips and lower back. A flexible person will be less likely to injure themselves in common activities, such as reaching, twisting and turning, or in uncommon activities such as the annual softball tournament.

Before stretching, take a few minutes to warm up the muscles because stretching a cold muscle can cause injury. Start your stretch slowly, exhaling as you gently stretch the muscle. Try to hold each stretch 15 to 30 seconds. Don't bounce when you stretch. Holding a stretch offers less chance of injury. Don't strain or push a muscle too far. If it hurts, ease up. Here are a few stretches you can incorporate into your exercise program:

SEATED TOE TOUCH (HAMSTRINGS & LOWER BACK)

Sit on the floor with your legs together and straight out in front of you. Do not lock your knees. Extend your fingers toward your toes, exhaling as you go. Hold for 15 to 30 seconds. Return to the start position, and repeat as necessary.

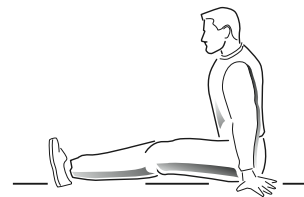

STANDING QUADRICEPS STRETCH

Using a wall to provide balance, grasp your left ankle with your left hand and hold to stretch. Your knee should be pointing toward the floor. Hold the stretch for 15 to 30 seconds. Repeat with your right leg, and continue to alternate as necessary.

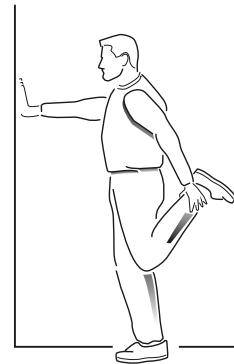

STANDING CALF STRETCH

Standing about three to four feet from the wall, take one step forward with your right foot. Place your hands on the wall in front of you. Bend your right leg slowly, using your movement to control the amount of stretch in the left calf. Your left heel should remain on the ground. Slowly bring yourself back to the starting position and switch legs. Repeat as necessary.

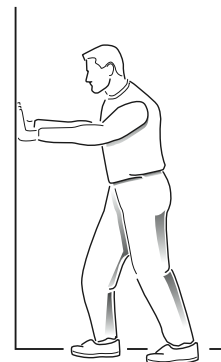

BICEP/CHEST STRETCH

Grasp an immovable object (pole or corner of a wall) with your feet planted firmly and evenly on the floor. With the palm of your stretched side facing forward, rotate your hips away from that hand. **Be careful not to rotate too far or hyperextend the elbow joint.** Hold the stretch for 15 to 30 seconds. Repeat with the opposite side, and continue to alternate as necessary.

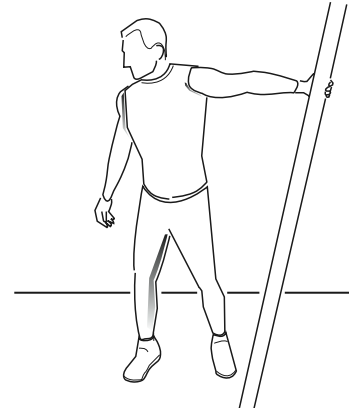

TRICEP STRETCH

Stand erect with your eyes fixated straight ahead. Raise and bend your right arm until your forearm is parallel to the floor (palm down). Grasp the area below the right elbow with your left hand. Gently apply a constant upward force for 15 to 30 seconds. Switch arms and repeat as necessary.



SHOULDER STRETCH

Make sure your feet are even and planted firmly on the floor. Grasp your right arm, behind the elbow, with your left hand. While keeping both elbows bent, apply a gentle, constant pull to the left for 15 to 30 seconds. Switch arms and repeat as necessary.

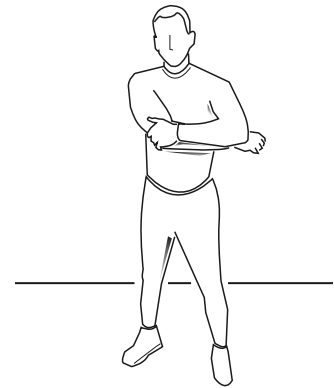

UPPER BACK STRETCH

Stand facing an immovable object, feet even and flat on the floor. Grasp the object (fingers interlocked or one hand over the other) and slowly move your hips to the rear. **Be very careful not to round your back.** Only stretch as far as your comfort zone. Hold for 15 to 30 seconds and repeat as necessary.

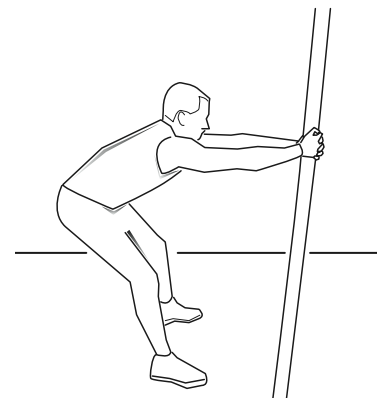

MAINTENANCE SCHEDULE

FOR *BEST* PERFORMANCE WE RECOMMEND THE FOLLOWING MAINTENANCE SCHEDULE:

Check the integrity and function of the following parts. Replace all worn components immediately.

ITEM	DAILY	WEEKLY
CABLES CHECK END FITTINGS AND CABLE JACKET COATING. CHECK TIGHTNESS OF WEIGHT STACK LOCKING NUT. REPLACE CABLES ANNUALLY.	•	•
UPHOLSTERY WIPE DOWN AND DRY. CLEAN AND CONDITION.	•	•
FRAME WIPE WITH WATER DAMPENED CLOTH AND DRY COMPLETELY. POLISH AND WAX.	•	•
CHROME WIPE WITH WATER DAMPENED CLOTH AND DRY COMPLETELY. POLISH AND WAX.	•	•
NUTS/BOLTS/FASTENERS TIGHTEN AND/OR ADJUST AS NEEDED.		•
GUIDE RODS LUBRICATE AND CLEAN.		•
ADJUSTMENTS/LOCKING PINS/TIGHTENING KNOBS		•
WEIGHT STACK PIN		•
WARNING/INSTRUCTION LABELS		•
ANTI-SKID GRIP TAPE		•
HAND GRIPS		•

ST780 COMMERCIAL WARRANTY*

COMMERCIAL USES DEFINED VISION FITNESS warrants the ST780 model Adjustable Bench for use in commercial facilities. Examples of commercial facilities include but are not limited to: Hotels; Resorts; Police and Fire Stations; Apartment Complexes; Rehabilitation and Sports Medicine Clinics; Hospitals; Elementary, Middle, and High Schools; YMCAs; Private Health Clubs; Colleges and Universities.

FRAME, WELDS, WEIGHT PLATES, & GUIDE RODS - LIFETIME VISION FITNESS warrants the Frame, Welds, Weight Plates and Guide Rods against defects in workmanship and materials for the life of the product, as long as it remains in the possession of the original owner.

BUSHINGS, ROTATING BEARINGS, & PULLEYS - FIVE YEARS VISION FITNESS warrants these components against defects in workmanship and materials for a period of five years from the date of original purchase, so long as the device remains in the possession of the original owner.

CABLES, LINEAR BEARINGS, SHAFTS, & OTHER PARTS - ONE YEAR VISION FITNESS warrants these components against defects in workmanship and materials for a period of one year from the date of original purchase, so long as the device remains in the possession of the original owner.

EXCLUSIVE REMEDY

The exclusive remedy for any of the above warranties shall be repair or replacement of defective parts.

EXCLUSIONS AND LIMITATIONS

This warranty applies only to the original owner and is not transferable. This warranty is expressly limited to the repair or replacement of a defective frame, electronic component, or defective part and is the sole remedy of the warranty. The warranty does not cover normal wear and tear, improper assembly or maintenance, or installation of parts or accessories not originally intended or compatible with the product as sold. This warranty does not cover failure to follow instructions and warnings in the Owner's Guide or failure to provide reasonable and necessary maintenance. This warranty does not apply to damage or failure due to accident, abuse, corrosion, discoloration of paint or plastic or neglect. VISION FITNESS shall not be responsible for incidental or consequential damages. Parts and electronic components reconditioned to As New Condition by VISION FITNESS or its vendors may sometimes be supplied as warranty replacement parts and constitute fulfillment of warranty terms. Any warranty replacement parts shall be warranted for the remainder of the original warranty term.

VISION FITNESS expressly disclaims all other warranties, express or implied, including but not limited to all warranties of fitness for a particular purpose or of merchantability. This warranty gives you specific rights and your rights may vary from state to state.

WARRANTY REGISTRATION

Your warranty card must be completed and sent to VISION FITNESS before a warranty claim can be processed. You may also register via our website at www.visionfitness.com. Inside the enclosed warranty card you will find a customer survey. Your care in completing the survey will be of value to us in serving you in the future. Comments and suggestions are always welcome. We are certain you will enjoy your new treadmill. Thank you for selecting a VISION FITNESS product.

*ST780 Commercial Warranty valid in North America only

Week #

Weekly Goals: _____

Scheduled Workout Time: _____

Reward: _____

<i>Day</i>	<i>Date</i>	<i>Exercise</i>	<i>Sets</i>	<i>Reps</i>	<i>Weight</i>
<i>Sunday</i>					
<i>Monday</i>					
<i>Tuesday</i>					
<i>Wednesday</i>					
<i>Thursday</i>					
<i>Friday</i>					
<i>Saturday</i>					
Totals					

Week #

Weekly Goals: _____

Scheduled Workout Time: _____

Reward: _____

<i>Day</i>	<i>Date</i>	<i>Exercise</i>	<i>Sets</i>	<i>Reps</i>	<i>Weight</i>
<i>Sunday</i>					
<i>Monday</i>					
<i>Tuesday</i>					
<i>Wednesday</i>					
<i>Thursday</i>					
<i>Friday</i>					
<i>Saturday</i>					
Totals					

Week #

Weekly Goals: _____

Scheduled Workout Time: _____

Reward: _____

Day	Date	Exercise	Sets	Reps	Weight
Sunday					
Monday					
Tuesday					
Wednesday					
Thursday					
Friday					
Saturday					
Totals					

Week #

Weekly Goals: _____

Scheduled Workout Time: _____

Reward: _____

Day	Date	Exercise	Sets	Reps	Weight
Sunday					
Monday					
Tuesday					
Wednesday					
Thursday					
Friday					
Saturday					
Totals					

*it all
starts
with a
v i s i o n*

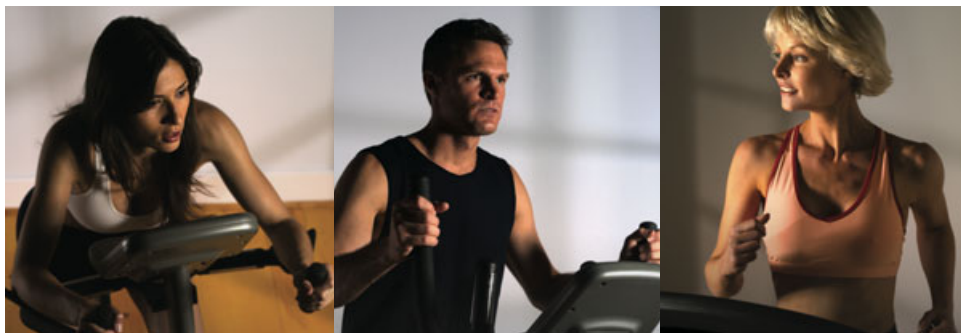

500 South CP Avenue • P.O. Box 280 • Lake Mills, WI 53551
toll free 800.335.4348 • phone 920.648.4090 • fax 920.648.3373
www.visionfitness.com

©2006 Vision Fitness. All Rights Reserved. 11.06
OM18.46PRD
REV1

Free Manuals Download Website

<http://myh66.com>

<http://usermanuals.us>

<http://www.somanuals.com>

<http://www.4manuals.cc>

<http://www.manual-lib.com>

<http://www.404manual.com>

<http://www.luxmanual.com>

<http://aubethermostatmanual.com>

Golf course search by state

<http://golfingnear.com>

Email search by domain

<http://emailbydomain.com>

Auto manuals search

<http://auto.somanuals.com>

TV manuals search

<http://tv.somanuals.com>