



Dear VIZIO Customer,

Congratulations on your new VIZIO purchase. Thank you for your support. For maximum benefit of your wall mount, please read these instructions before installation and retain them for future reference. We hope you will experience many years of enjoyment from your new VIZIO wall mount.

For assistance, please call **(877) 668-8462** or e-mail us at www.vizio.com.

To inquire about installation services for your VIZIO wall mount, please visit our website at www.vizio.com or call toll free at **(888) 849-4623**.

We recommend you register your wall mount either at our website www.VIZIO.com or fill out and mail your registration card.

Purchase Date _____

VIZIO is a registered trademark of VIZIO, Inc. dba V, Inc.

THE TRADEMARKS SHOWN HEREIN ARE THE PROPERTY OF THEIR RESPECTIVE OWNERS; IMAGES USED ARE FOR ILLUSTRATION PURPOSES ONLY. BRAVO, VIZIO AND THE V LOGO AND WHERE VISION MEETS VALUE AND OTHER VIZIO TRADEMARKS ARE THE INTELLECTUAL PROPERTY OF VIZIO INC. PRODUCT SPECIFICATIONS ARE SUBJECT TO CHANGE WITHOUT NOTICE OR OBLIGATION. © 2009 VIZIO INC. ALL RIGHTS RESERVED.



Table of Contents

Important Safety Instructions	2
SECURING WALL MOUNT TO WALL	5
Wood Stud Walls	5
Concrete Walls	6
ATTACH BRACKETS TO TV	7
ATTACH TV TO MOUNT	7
ATTACH TV TO MOUNT	8
CONNECT CABLES	9
OPTIONAL: ADJUST UPRIGHT POSITION OF THE TV	10
ADJUST TILT FOR VIEWING	11
USING THE REMOTE CONTROL	12
TROUBLESHOOTING GUIDE	13
Telephone & Technical Support.....	14
ONE-YEAR LIMITED WARRANTY & INSURANCE.....	14

Important Safety Instructions

Follow the instructions within this manual and review these safety instructions before attempting to install or use this mounting system.

- Manufacturer is not liable for damage or injury caused by incorrect mounting, assembly, or use. The TV must not be larger than 60 inches (152cm) and weigh not more than 105 lbs (48 Kg).
- Attaching a TV that is heavier than the maximum weight specified above may result in instability, and possible personal injury.
- Only attach this mount system on vertical walls as instructed in this installation/user's manual.
- **This product is not designed for use in metal stud walls!**
- If you have any doubts about the ability of the wall to support the TV and the mounting system, contact a qualified contractor. This product contains small items that could be a choking hazard if swallowed. Keep these items away from children!
- Do not run any wires and/or cables near moving parts of this mounting system.
- Electrical Rating: DC12V, 0.4A

Opening the Package

Before starting installation, verify that all parts are included and undamaged. If any parts are missing or damaged contact customer service at (877) 698-4946.











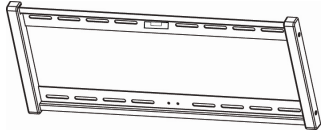

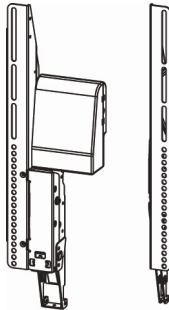

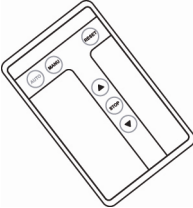

IMPORTANT: Save the carton and packing material for future shipping.

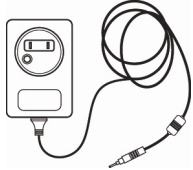
Tools Needed











- Stud Finder
- 7/16" wrench
- 7/16" socket & wrench
- Phillips screwdriver
- Drill with 3/16" (wood) or 1/2" (concrete) drill bit

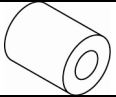

Package Contents

Item #	Qty	Description	Image	Item #	Description	Qty	Image
1	1	Wall Plate		16	M4 x 30mm	4	
2 & 3	1 ea	Brackets		17	M5 x 30mm	4	
4	1	Pin		18	M6 x 35mm	4	
5	1	Remote Control		19	M8 x 40mm	4	
6	1	AC Adapter Jack		20	M4	4	
7	1	IR receiver jack		21	M5	4	
8	1	Optical Cable		22	M6	4	
9	6	Lag Bolt		23	M8	4	

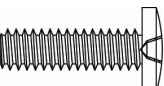

10	6	5/16"		24	M4/M5	4	
11	6	Concrete Anchor		25	M6/M8	4	
12	4	M4 x 12mm		26	M4/M5	8	
13	4	M5 x 12mm		27	M6/M8	4	
14	4	M6 x 12mm		28	M6 x 20mm	4	
15	4	M8 x 16mm					



Securing Wall Mount to Wall

Caution: This product is not designed for use in metal stud walls

Wood Stud Walls

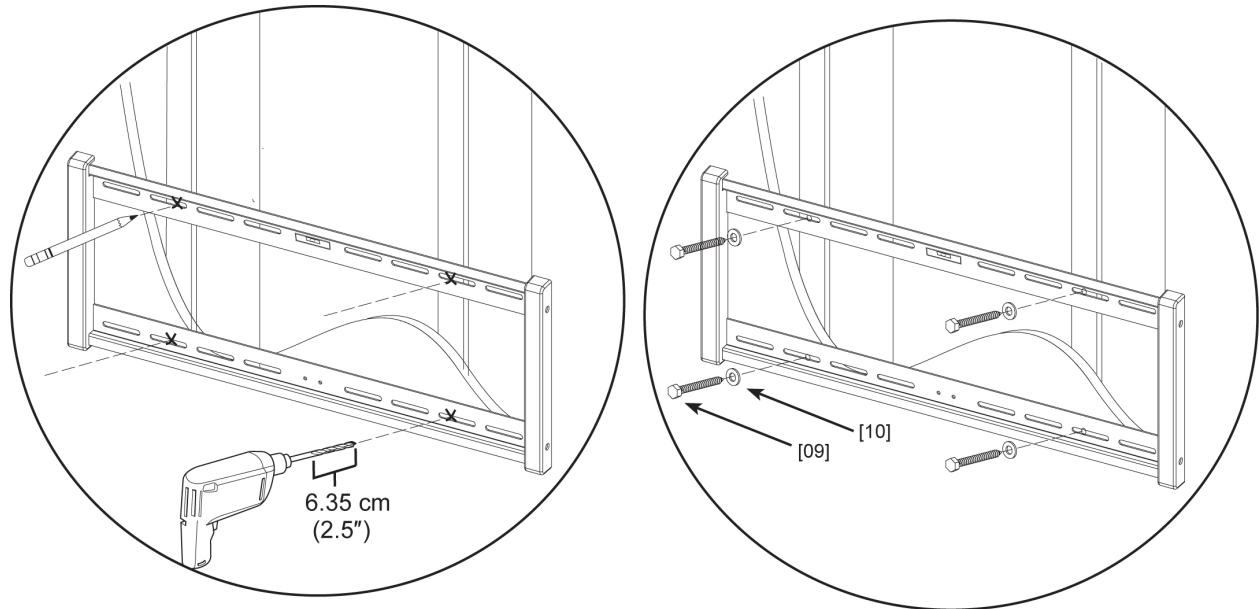

Note: You must attach the TV wall mount to a wall that has at least 2" x 4" wood studs to avoid property damage or injury.

Locate wall studs

1. Using a stud finder, locate two wood studs that are 16" to 24" apart.
2. With a pencil, mark the location of the studs.

Mark and drill holes

1. Tape the included poster to the wall so the holes align with the studs. Use the built-in level on the wall plate [1] to make sure the poster is level. Put the wall plate [1] aside.
2. Drill 4 holes with the 3/16" drill bit, 2-1/2" deep. Remove the poster.

Anchor mount to wall

1. Using a 7/16" wrench, attach the wall plate [1] to the wall with the supplied lag bolts and washers [9] & [10].
2. Use the level before tightening bolts.

Note: Do not over-tighten lag bolts. Tighten only until they are firmly against the wall plate.

OR



Concrete Walls

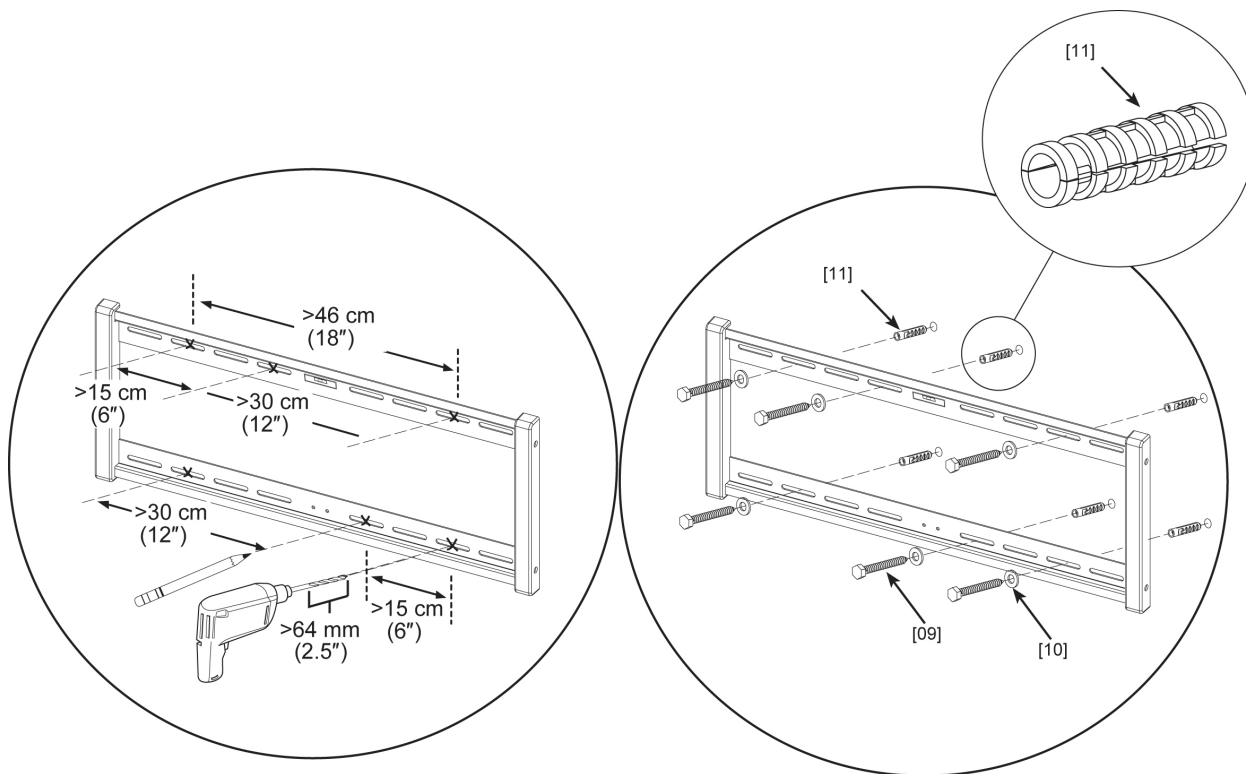

Mark and drill holes

1. Tape the included poster to the wall. Hold the wall plate [1] up to the poster and use the built-in level to make sure it is level. Put the wall plate [1] aside.
2. Drill 6 holes with a 1/2" masonry bit, 2-1/2" deep where indicated. Remove the poster.

Install anchors

1. Install the provided anchors [11] in the holes, flush with the wall so that the hinged end faces out.

Anchor mount to wall

3. Using a 7/16" wrench, attach the wall plate [1] to the wall with the supplied lag bolts and washers [9] & [10].
4. Use the level before tightening bolts.

Note: Do not over-tighten lag bolts. Tighten only until they are firmly against the wall plate.



Attach Brackets to TV

Caution: Make sure you use the correct depth of screw for your TV. Using screws that are too long or too short can damage your TV. Use washer [26] with M4 or M5 hardware only. Use washer [27] with M6 or M8 hardware only. If the TV has a curved back, spacers [24] or [25] may be necessary.

Use the screws provided with the TV or screws if they hold the bracket securely, otherwise use the appropriate screws from those provided.

TV with Flat back

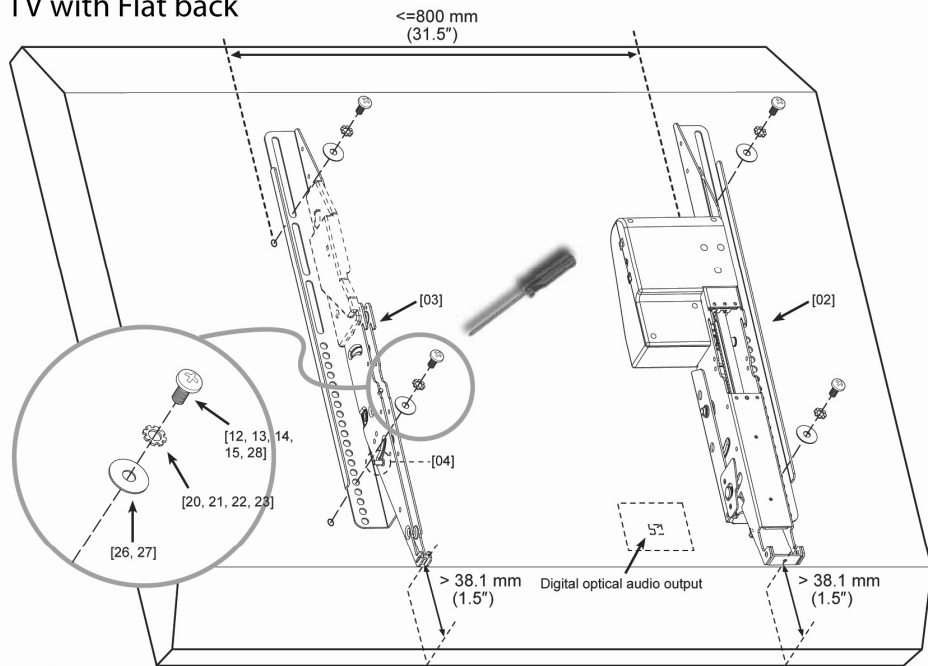

OR

TV with Curved back

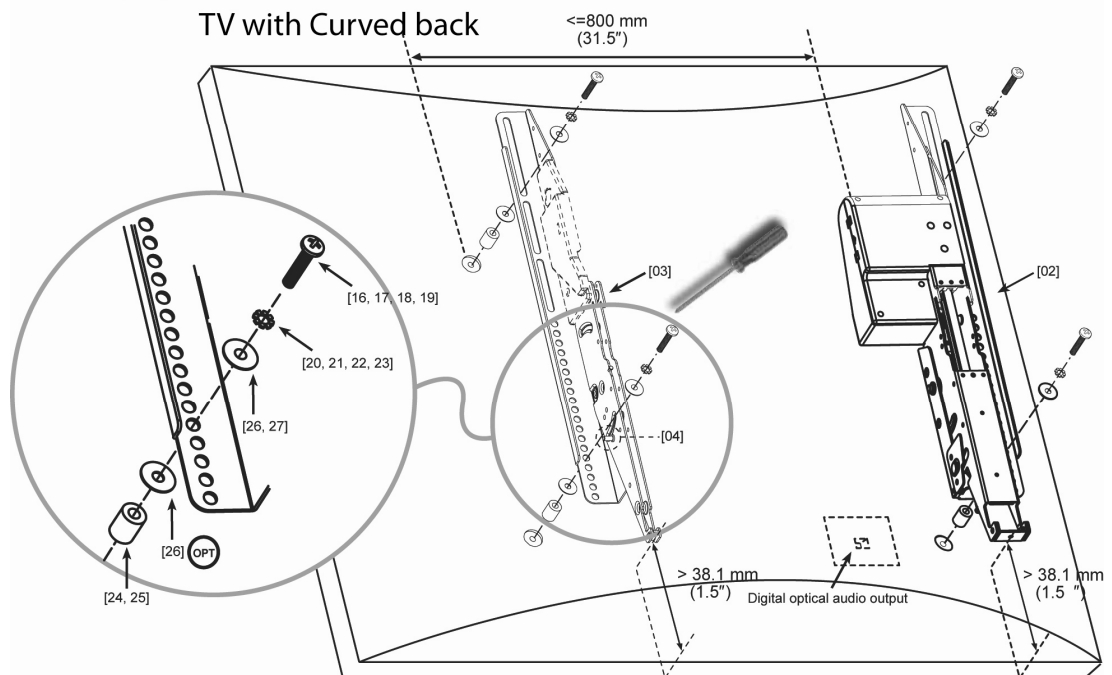

Attach TV to Mount

Caution: For safety, we recommend having two people lift the TV onto the mount.

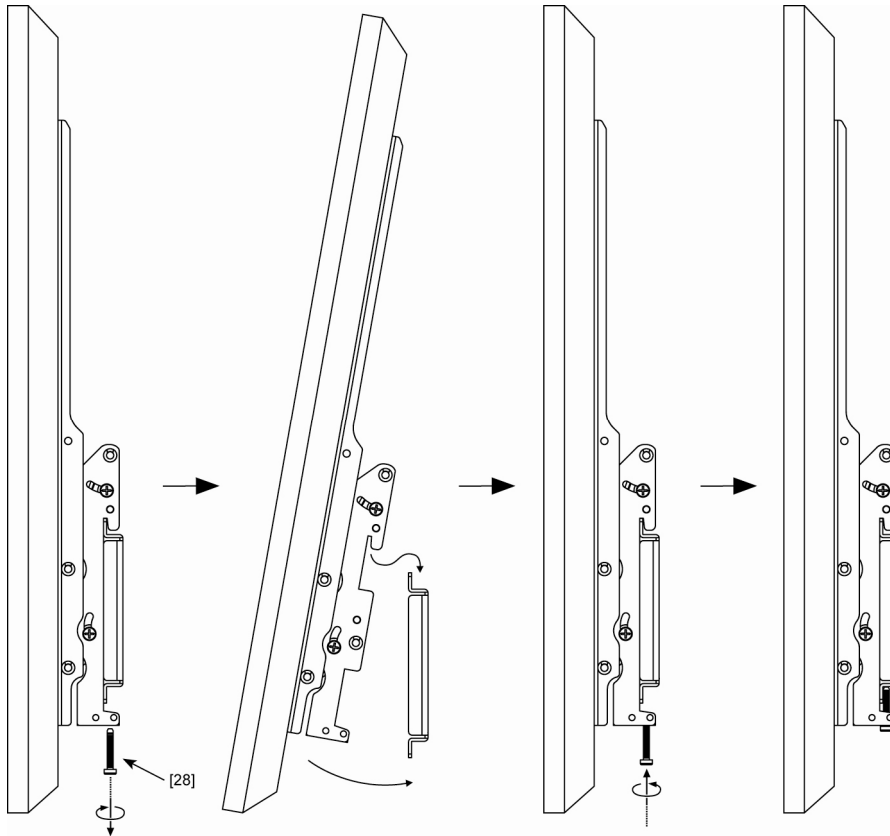

1. Remove both safety screws from the bottom of each bracket.
2. Lift TV onto mount
3. Replace safety screws into bottom of brackets and tighten to secure to mount.



Connect Cables

Caution: Do not run any cables near moving parts.

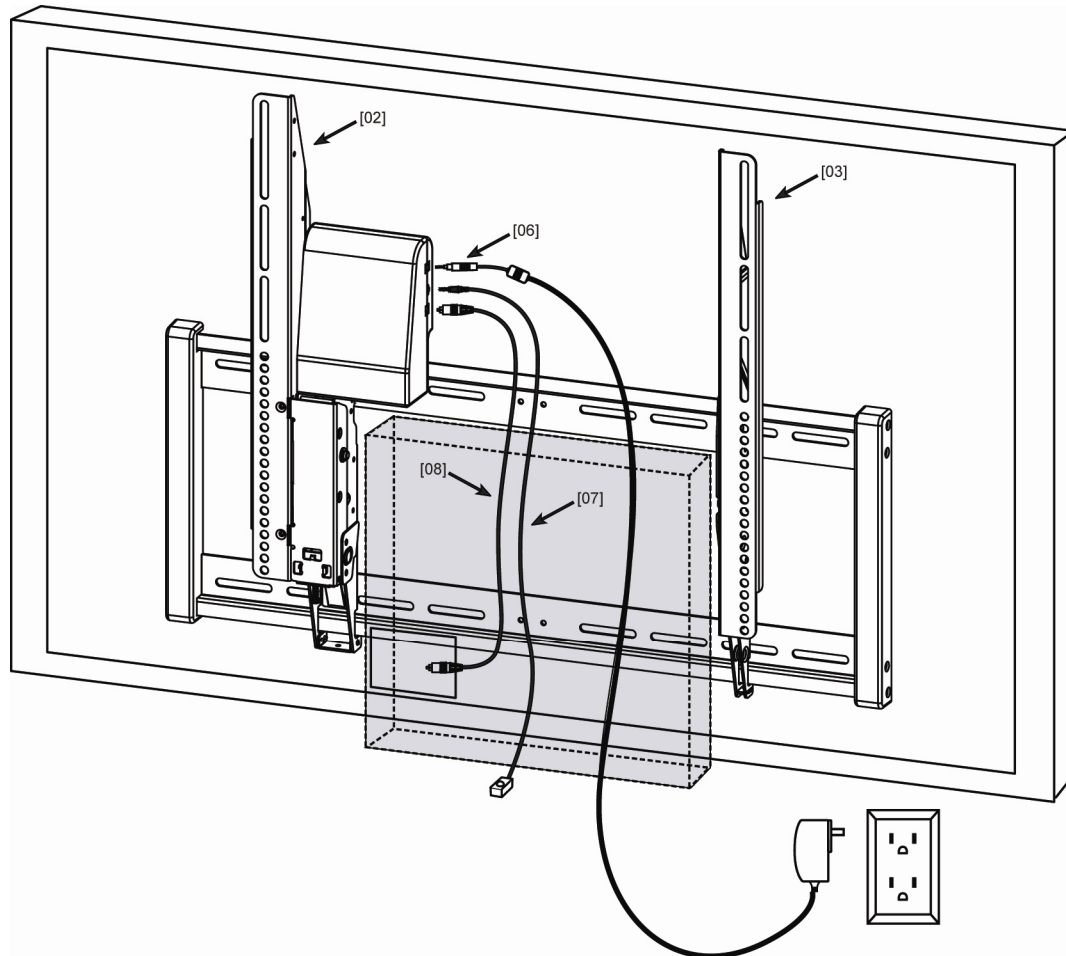

1. Tilt TV up and insert pin [04] into the "UP" position. See next step.
2. Insert IR receiver jack [07] into the control box, and attach the head of the IR receiver to the bottom of the TV so it is visible from the front.
3. Insert one end of the optical cable [08] to the control box and the other end to the Digital Optical Audio Output on the back of the TV.
4. Insert the AC adapter jack [06] into the control box, and then into an electrical outlet.



Optional: Adjust upright position of the TV

If desired, adjust the upright position of the TV by $\pm 2^\circ$ by turning the bottom screw on the motorized bracket [02].

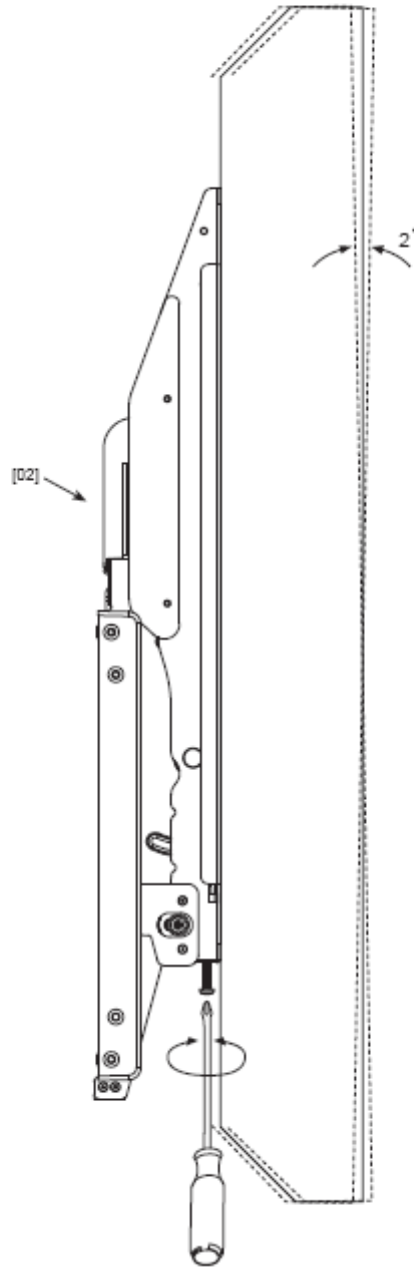

Adjust Tilt for Viewing

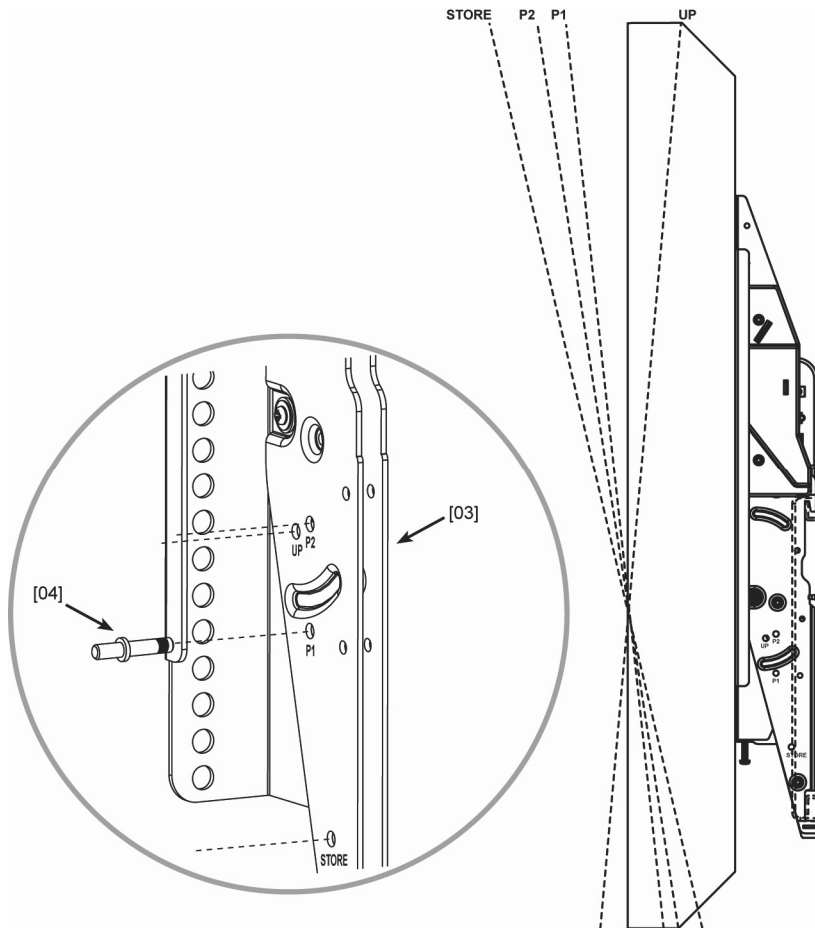

Tighten the pin [04] into:

- P1 for maximum tilt of ~ 6°
- P2 for maximum tilt of ~ 9°
- STORE for full 13° tilt down, and to store the pin
- UP to hold the TV up ~ 5°



Using the Remote Control

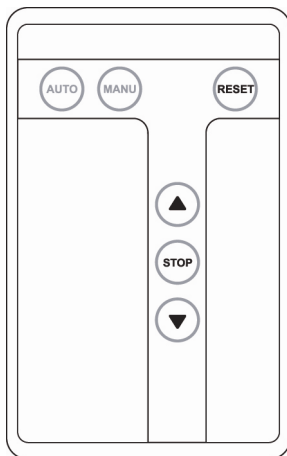

Remote Buttons	Function Description
Up Key ▲	Tilts the TV up.
Down Key ▼	Tilts the TV down to a maximum of 13°
STOP	Stops the movement
AUTO	The factory default setting is Auto-Mode. If your TV is provided with a Digital Optical Audio Output, and the optical cable [08] has been installed as instructed in the “Connect Cables” section, then the Auto-Mode is functional. In Auto-Mode, the program will automatically tilt down the TV when the TV is turned ON; and return the TV to the upright position, when the TV is turned OFF. During operation, the UP/DOWN/STOP buttons will override the Auto-Mode. The next time the TV is turned ON or OFF, the program will go back to the Auto-Mode.
MANU	“MANU” turns off the Auto-Mode. The program will only operate with the remote control buttons.
RESET	Pressing the RESET key twice within 1 second will reset the program back to the factory default settings, which is the Auto-Mode.



Troubleshooting Guide

If the VMT40-55M fails to operate, or the performance changes dramatically, check the operation in accordance with the following instructions. If the VMT40-55M still fails to perform as expected, contact the VIZIO for assistance by calling 1-877-MYVIZIO (1-877-698-4946) or e-mail us at techsupport@vizio.com.

General TV Problems	Solution
TV does not fully tilt down	<ul style="list-style-type: none"> The mounting system relies on the weight of TV to tilt down the TV. Check to see if there is any foreign object such as wire and cable stopping the TV from tilting down. If so, remove or relocate the foreign object. Refer to <i>Connect Cables</i>. Check to see if the pin [04] is not in the "P1", "P2", or "UP" hole in the non-motorized bracket [03]. Refer to <i>Adjust Tilt for Viewing</i>.
TV stops moving up in middle of its operation	<ul style="list-style-type: none"> Check to see if a foreign object is impeding the TV from moving upwards. If so, remove or relocate the foreign object. If the TV weight exceeds 105 lbs (48 Kg), then do NOT use this product to support the overweight TV. Program may be malfunctioning. Reset to factory setting by pressing "RESET" button on the remote control [05]. Refer to <i>Using the Remote Control</i>.
TV does not automatically tilt down and up when the TV is turned ON and OFF	<ul style="list-style-type: none"> "MANU" button may have been accidentally pushed. Push the "AUTO" button on the remote control [05] to reset to Auto-Mode. Refer to <i>Using the Remote Control</i>. Check to see if the optical cable [08] has been disconnected. Refer to <i>Connect Cables</i>.
The automated mount does not respond to remote control commands	<ul style="list-style-type: none"> The IR receiver jack [07] may be disconnected from the control box. Refer to <i>Connect Cables</i>. The IR receiver head [07] may be located in a poor location where it is difficult to receive the IR signal from the remote control [05]. Relocate the IR receiver head. Refer to <i>Connect Cables</i>. The AC power adapter jack [06] may be disconnected from the control box. Refer to <i>Connect Cables</i>. A foreign object may be impeding the movement of the TV. The batteries in the remote control [05] may be bad. Replace the batteries.
TV leans forward in the upright position	<ul style="list-style-type: none"> The weight of the TV is making the TV lean forward. Refer to <i>Adjust upright position of the TV</i>.



Telephone & Technical Support

Products are often returned due to a technical problem rather than a defective product that may result in unnecessary shipping charges billed to you. Our trained support personnel can often resolve the problem over the phone. For more information on warranty service or repair, after the warranty period, please contact our Support Department at the number below.

Customer support and quality service are integral parts of VIZIO's commitment to service excellence. For technical assistance contact our VIZIO Technical Support Department via email or phone.

Email: techsupport@vizio.com

(877) 698-4946 Fax: (949) 585-9563

Hours of operation: Monday - Friday: 6 am to 9 pm

Saturday – Sunday: 8 am to 4 pm

Please have your VIZIO model number, serial number, and date of purchase available before you call.

VIZIO

Address:

39 Tesla

Irvine, CA 92618, USA

Telephone: (949) 428-2525 Fax: 949-585-9514

Web: www.vizio.com

ONE-YEAR LIMITED WARRANTY & INSURANCE

Covers units purchased as new in United States and Puerto Rico Only

VIZIO warrants for a period of one (1) year from the date of purchase to the original purchaser of its mounting brackets, that the bracket shall be free from defects in assembly, material, or workmanship and will repair or replace, at its sole discretion, a defective bracket free of charge, provided the bracket is returned to VIZIO with shipping prepaid by purchaser. Unauthorized service or repairs by anyone other than VIZIO or a pre-approved repair facility renders this warranty void and shall release VIZIO from any further responsibility or obligation.

Insurance: VIZIO will repair or replace up to a maximum of \$10,000.00, at its option, any component (television, projector, monitor or screen) which is damaged by a VIZIO bracket's failure to perform* when that product is properly installed** for its intended use. This insurance is subject to the limitations and exclusions set forth herein. VIZIO will repair or replace the damaged television, monitor or screen ("Components") at VIZIO's option, up to an amount equal to the fair market value of the damaged Components or the original purchase price of the equipment, whichever is less, up to \$10,000.00.

Other Terms & Conditions: VIZIO reserves the right to inspect the damaged component, the VIZIO bracket alleged to have failed, and the site where the damage occurred. Damaged Components and bracket must remain available for inspection until the claim is finalized. VIZIO may require you to ship, at your expense, the VIZIO bracket and damaged Component to VIZIO for inspection. VIZIO reserves the right to negotiate the costs of repair. If VIZIO determines, in its sole discretion, that it is impractical to ship the damaged component or bracket, VIZIO may designate, in its sole discretion, a component repair facility to inspect and estimate the cost to repair. The cost, if any, of shipping the Component to and from such repair facility and of such estimate shall be borne solely by the purchaser. Whenever claims are settled, VIZIO reserves the right to be subrogated under any existing insurance policies the claimant/purchaser may have.

All above warranties and insurance are null and void if: the VIZIO bracket in use during the occurrence is not provided to VIZIO for inspection upon VIZIO's request at the sole expense of the



purchaser; or if VIZIO determines that the VIZIO bracket has been improperly installed, altered in any way or tampered with; or if it is determined by VIZIO that the damage did not result from the VIZIO product's failure or that in fact no occurrence took place; or the repair or replacement of the damaged Component is covered under a manufacturer's warranty; or VIZIO determines that the Component was not used under normal operating conditions or in accordance with any labels or instructions. Improper installation voids this Limited Warranty & Insurance. VIZIO's Limited Warranty & Insurance only protects against damage to properly connected and installed Components where VIZIO has determined, in its sole discretion, that the damage resulted from a VIZIO bracket's failure, and does not protect against acts of God such as flood, earthquake, war, vandalism, theft, normal-use wear and tear, corrosion, misuse or abuse. Any damage caused by failure to observe instructions for installation, or product limitations specified in the product manual or product specification sheet, or mounting on unsuitable surfaces will not be covered by the VIZIO's Limited Warranty & Insurance.

The protections described herein shall be IN LIEU OF any other warranty, express or implied, including but not limited to, any warranty of MERCHANTABILITY or FITNESS FOR A PARTICULAR PURPOSE.

In no event shall VIZIO be liable for incidental, special, direct, indirect consequential or multiple damages such as, but not limited to, lost business or profits arising out of the sale, use or inability to sell or use any VIZIO products, even if advised of the possibility of damages. This Limited Warranty & Insurance gives you specific legal rights, and you may also have other rights, which may vary from state to state. Some states do not allow the exclusion of limitation of incidental or consequential damage so the above limitations may not apply to you.

This Limited Warranty & Insurance is valid only for the original purchaser of the product and only if the original purchaser registers the purchase on-line at www.VIZIO.com or by mailing a copy of the purchase receipt (showing the date of purchase) and product warranty registration card to VIZIO, 39 Tesla, Irvine, CA 92618. All damage claims must be made to VIZIO within fifteen (15) days from the date of the occurrence and must be accompanied by the purchase receipt for the damaged bracket or this Limited Warranty & Insurance is void. This Limited Warranty & Insurance is only valid in USA and Canada. To make a warranty or insurance claim, please call (877) MY VIZIO (877-698-4946) within fifteen (15) days of the occurrence. Please provide to us or have the following information available:

- a. The date of the occurrence and the part number of the VIZIO bracket involved.
- b. The Component that was used with the VIZIO bracket at the time of the occurrence.
- c. The Component that was damaged during the occurrence and the extent of the damage.
- d. A detailed description of any additional damage from the occurrence.***
- e. A legible copy of the original receipt showing the place and date of purchase of the VIZIO bracket.
- f. A legible copy of the original receipt for the damaged Component.
- g. Photo(s) of any claimed damage.
- h. Serial number located on the carton box and control box.

* Failure to perform in accordance with that bracket's specifications sheet or product manual.

** Properly installed in accordance with that bracket's installation instruction sheet or bracket manual and only when mounted on approved surfaces.

***VIZIO reserves the right to require additional supporting evidence to substantiate any additional damage claims.



Free Manuals Download Website

<http://myh66.com>

<http://usermanuals.us>

<http://www.somanuals.com>

<http://www.4manuals.cc>

<http://www.manual-lib.com>

<http://www.404manual.com>

<http://www.luxmanual.com>

<http://aubethermostatmanual.com>

Golf course search by state

<http://golfingnear.com>

Email search by domain

<http://emailbydomain.com>

Auto manuals search

<http://auto.somanuals.com>

TV manuals search

<http://tv.somanuals.com>