

VocoPro

THE SINGER'S ULTIMATE CHOICE

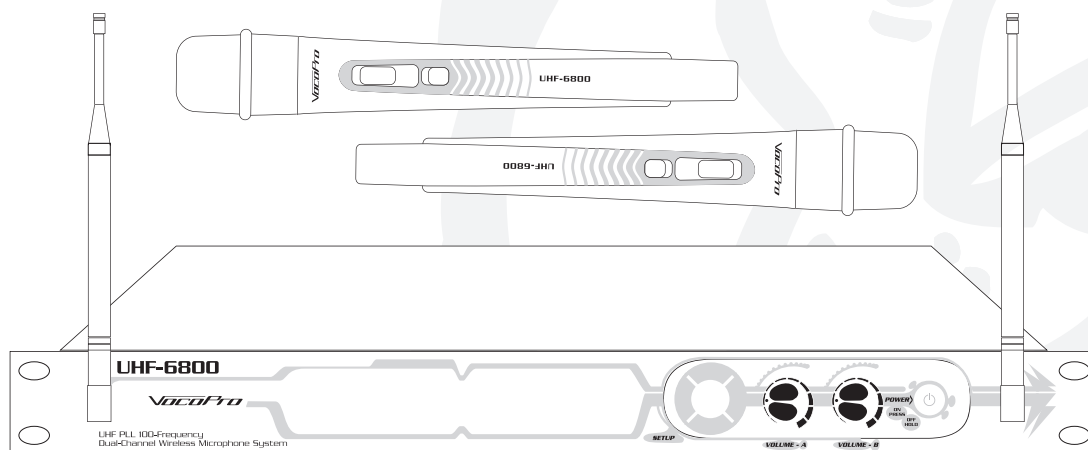

UHF-6800

UHF PLL 100-Frequency Dual-Channel Wireless Microphone System

owner's manual

Table of contents

Introduction

Safety instructions	2
FCC information.....	3
Welcome	4
Listening for a lifetime	5
Specifications and features.....	6

Getting Started

Mounting the UHF-6800	7
Connecting the antennas	8
Connecting the AC adapter	8
Installing new batteries.....	8
Setting up stage	9

Getting Connected

Connecting to a mixer	10
Connecting to an all-in-one system.....	10

Controls and Functions

Front panel	11
Rear panel	12
Microphone	13

Microphone Basics

Microphone position.....	14
Feedback.....	14
Microphone placement & tone quality	14

Operations

Turning on/off the UHF-6800 receiver.....	15
Turning on/off the UHF-6800 microphone.....	15
Balancing the volume	15
Selecting a frequency	16
Changing the display.....	16
Locking a frequency	17
Adjusting the squelch	18
Setting the RF power level.....	18

Troubleshooting

Basic troubleshooting	19
-----------------------------	----



Safety instructions



CAUTION RISK OF SHOCK



CAUTION: To reduce the risk of electric shock, do not remove cover (or back). No user-serviceable parts inside. Only refer servicing to qualified service personnel.

Explanation of Graphical Symbols



The lightning flash & arrowhead symbol, within an equilateral triangle, is intended to alert you to the presence of danger.



The exclamation point within an equilateral triangle is intended to alert you to the presence of important operating and servicing instructions.

WARNING

To reduce the risk of fire or electric shock, do not expose this unit to rain or moisture.

1. Read Instructions - All the safety and operating instructions should be read before the appliance is operated.

2. Retain Instructions - The safety and operating instructions should be retained for future reference.

3. Heed Warnings - All warnings on the appliance and in the operating instructions should be adhered to.

4. Follow Instructions - All operating and use instructions should be followed.

5. Attachments - Do not use attachments not recommended by the product manufacturer as they may cause hazards.

6. Water and Moisture - Do not use this unit near water. For example, near a bathtub or in a wet basement and the like.

7. Carts and Stands - The appliance should be used only with a cart or stand that is recommended by the manufacturer.

7 A. An appliance and cart combination should be moved with care. Quick stops, excessive force, and uneven surfaces may cause an overturn.



8. Ventilation - The appliance should be situated so its location does not interfere with its proper ventilation. For example, the appliance should not be situated on a bed, sofa, rug, or similar surface that may block the ventilation slots.

9. Heat - The appliance should be situated away from heat sources such as radiators, heat registers, stoves, or other appliances (including amplifiers) that produce heat.

10. Power Sources - The appliance should be connected to a power supply only of the type described in the operating instructions or as marked on the appliance.

11. Grounding or Polarization - Precautions should be taken so that the grounding or polarization means of an appliance is not defeated.

12. Power-Cord Protection - Power-supply cords should be routed so that they are not likely to be walked on or pinched by items placed upon or against them, paying particular attention to cords at plugs, convenience receptacles, and the point where they exit from the appliance.

13. Cleaning - Unplug this unit from the wall outlet before cleaning. Do not use liquid cleaners or aerosol cleaners. Use a damp cloth for cleaning.

14. Power lines - An outdoor antenna should be located away from power lines.

15. Nonuse Periods - The power cord of the appliance should be unplugged from the outlet when left unused for a long period of time.

16. Object and Liquid Entry - Care should be taken so that objects do not fall and liquids are not spilled into the enclosure through openings.

17. Damage Requiring Service - The appliance should be serviced by qualified service personnel when:

- A. The power supply cord or plug has been damaged; or
- B. Objects have fallen into the appliance; or
- C. The appliance has been exposed to rain; or
- D. The appliance does not appear to operate normally or exhibits a marked change in performance; or
- E. The appliance has been dropped, or the enclosure damaged.

18. Servicing - The user should not attempt to service the appliance beyond that described in the operating instructions. All other servicing should be referred to qualified service personnel.

Note:

To CATV system installer's (U.S.A.): This reminder is provided to call the CATV system installer's attention to Article 820-40 of the NEC that provides guidelines for proper grounding and, in particular, specifies that the cable ground shall be connected as close to the point of cable entry as practical.

FCC information (U.S.A.)

1. IMPORTANT NOTICE: DO NOT MODIFY THIS

UNIT!: This product, when installed as indicated in the instructions contained in this manual, meets FCC requirements. Modifications not expressly approved by Vocopro may void your authority, granted by the FCC, to use this product.

2. IMPORTANT: When connecting this product to accessories and/or another product use only high quality shielded cables. Cable(s) supplied with this product **MUST** be used. Follow all installation instructions. Failure to follow instructions could void your FCC authorization to use this product in the U.S.A.

3. NOTE: This product has been tested and found to comply with the requirements listed in FCC Regulations, Part 15 for Class "B" digital devices. Compliance with these requirements provides a reasonable level of assurances that your use of this product in a residential environment will not result in harmful interference with other electronic devices. This equipment generates/uses radio frequencies and, if not installed and used according to the instructions found in the owner's manual, may cause interference harmful to the operation of other electronic devices. Compliance with FCC regulations does not guarantee that interference will not occur in all installations. If this product is found to be the source of interference, which can be determined by turning the unit "Off" and "On", please try to eliminate the problem by using one of the following measures:

Relocate either this product or the device that is being affected by the interference.

Use power outlets that are on different branch (circuit breaker or fuse) circuits or install AC line filter(s).

In the case of radio or TV interference, relocate/reorient the antenna. If the antenna lead-in is 300-ohm ribbon lead, change the lead-in to coaxial type cable.

If these corrective measures do not produce satisfactory results, please contact your local retailer authorized to distribute Vocopro products. If you can not locate the appropriate retailer, please contact Vocopro, 1728 Curtiss Court, La Verne, CA 91750.

CAUTION

The apparatus is not disconnected from the AC power source so long as it is connected to the wall outlet, even if the apparatus itself is turned off. To fully insure that the apparatus is indeed fully void of residual power, leave unit disconnected from the AC outlet for at least fifteen seconds.

CAUTION:

READ THIS BEFORE OPERATING YOUR UNIT

1. To ensure the finest performance, please read this manual carefully. Keep it in a safe place for future reference.
2. Install your unit in a cool, dry, clean place - away from windows, heat sources, and too much vibration, dust, moisture or cold. Avoid sources of hum (transformers, v motors). To prevent fire or electrical shock, do not expose to rain and water.
3. Do not operate the unit upside-down.
4. Never open the cabinet. If a foreign object drops into the set, contact your dealer.
5. Place the unit in a location with adequate air circulation. Do not interfere with its proper ventilation; this will cause the internal temperature to rise and may result in a failure.
6. Do not use force on switches, knobs or cords. When moving the unit, first turn the unit off. Then gently disconnect the power plug and the cords connecting to other equipment. Never pull the cord itself.
7. Do not attempt to clean the unit with chemical solvents: this might damage the finish. Use a clean, dry cloth.
8. Be sure to read the "Troubleshooting" section on common operating errors before concluding that your unit is faulty.
9. This unit consumes a fair amount of power even when the power switch is turned off. We recommend that you unplug the power cord from the wall outlet if the unit is not going to be used for a long time. This will save electricity and help prevent fire hazards. To disconnect the cord, pull it out by grasping the plug. Never pull the cord itself.
10. To prevent lightning damage, pull out the power cord and remove the antenna cable during an electrical storm.
11. The general digital signals may interfere with other equipment such as tuners or receivers. Move the system farther away from such equipment if interference is observed.

NOTE:

Please check the copyright laws in your country before recording from records, compact discs, radio, etc. Recording of copyrighted material may infringe copyright laws.

Voltage Selector (General Model Only)

Be sure to position the voltage selector to match the voltage of your local power lines before installing the unit.

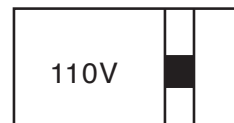

Welcome



VocoPro
ULTIMATE CHOICE OF KARAOKE ENTERTAINMENT

And Thank you for purchasing the **UHF-6800** from VocoPro, your ultimate choice in Karaoke entertainment! With years of experience in the music entertainment business, VocoPro is a leading manufacturer of Karaoke equipment, and has been providing patrons of bars, churches, schools, clubs and individual consumers the opportunity to sound like a star with full-scale club models, in-home systems and mobile units. All our products offer solid performance and sound reliability, and to reinforce our commitment to customer satisfaction, we have customer service and technical support professionals ready to assist you with your needs. We have provided some contact information for you below.

VocoPro

1728 Curtiss Court
La Verne, CA 91750

Toll Free: 800-678-5348

TEL: 909-593-8893

FAX: 909-593-8890

VocoPro Company Email Directory

Customer Service & General Information

info@vocopro.com

Tech Support

techsupport@vocopro.com

Remember Our Website

Be sure to visit the VocoPro website **www.vocopro.com** for the latest information on new products, packages and promos. And while you're there don't forget to check out our Club VocoPro for Karaoke news and events, chat rooms, club directories and even a KJ Service directory!

We look forward to hearing you sound like a PRO, with VocoPro, your ultimate choice in Karaoke entertainment.

FOR YOUR RECORDS

Please record the model number and serial number below, for easy reference, in case of loss or theft. These numbers are located on the rear panel of the unit. Space is also provided for other relevant information.

Model Number _____

Serial Number _____

Date of Purchase _____

Place of Purchase _____

Listening for a lifetime

Selecting fine audio equipment such as the unit you've just purchased is only the start of your musical enjoyment. Now it's time to consider how you can maximize the fun and excitement your equipment offers. VocoPro and the Electronic Industries Association's Consumer Electronics Group want you to get the most out of your equipment by playing it at a safe level. One that lets the sound come through loud and clear without annoying blaring or distortion and, most importantly, without affecting your sensitive hearing.

Sound can be deceiving. Over time your hearing "comfort level" adapts to a higher volume of sound. So what sounds "normal" can actually be loud and harmful to your hearing. Guard against this by setting your equipment at a safe level BEFORE your hearing adapts.

To establish a safe level:

- Start your volume control at a low setting.
- Slowly increase the sound until you can hear it comfortably and clearly, and without distortion.

Once you have established a comfortable sound level:

- Set the dial and leave it there.
- Pay attention to the different levels in various recordings.

Taking a minute to do this now will help to prevent hearing damage or loss in the future. After all, we want you listening for a lifetime.

Used wisely, your new sound equipment will provide a lifetime of fun and enjoyment. Since hearing damage from loud noise is often undetectable until it is too late, this manufacturer and the Electronic Industries Association's Consumer Electronics Group recommend you avoid prolonged exposure to excessive noise. This list of sound levels is included for your protection.

Some common decibel ranges:

Level	Example
30	Quiet library, Soft whispers
40	Living room, Refrigerator, Bedroom away from traffic
50	Light traffic, Normal Conversation
60	Air Conditioner at 20 ft., Sewing machine
70	Vacuum cleaner, Hair dryer, Noisy Restaurant
80	Average city traffic, Garbage disposals, Alarm clock at 2 ft.

The following noises can be dangerous under constant exposure:

Level	Example
90	Subway, Motorcycle, Truck traffic, Lawn Mower
100	Garbage truck, Chainsaw, Pneumatics drill
120	Rock band concert in front of speakers
140	Gunshot blast, Jet plane
180	Rocket launching pad

-Information courtesy of the Deafness Research Foundation

Features and specifications

Features

- UHF System ranges from 700MHz - 850MHz
- Two mic channels each with individual volume controls
- PLL synthesized for an even clearer signal
- 100 manually switchable frequency channels to avoid interference
- Individual Balanced XLR outputs and one ¼" Mixed output
- Individual Squelch controls for each channel
- Detachable antennas
- LCD displays on mics and receiver
- Low battery indicator on each mic
- Rack-mountable in 19" rackcase and requires just 1 RU

Specifications

Frequency range.....	620-950MHz
Band range.....	25MHz
Frequency stability	±0.005%
Active range	110dB
Peak frequency.....	±45KHz
Frequency response.....	60Hz-18KHz (±3dB)
Noise ratio	>105dB
Default ratio.....	<0.5%

Receiver

Wireless input.....	BNC Jack
Sensitivity	12dB(80dBs / N)
Noise limit	0 - 40dB
Noise resistance	>80dB
Frequency/output: Unbalanced.....	+4dB(1.2V) / 5K Ohms
Balance.....	+10dB(2.5V) / 600 Ohms
Voltage.....	DC11 - 16V
Current:	
Single Channel.....	200mA
Dual Channel.....	350mA

Microphone (Transmitter)

Output power	30mW/5mW (HI/LO switch)
Noise resistance	-60dB
Battery	AA x 2
Current.....	<80MA (low powered); <110MA (high powered)

NOTE: All information is subject to change without prior notice



Getting started

Mounting the UHF-6800

The UHF-6800 can be mounted into a 19" rackcase and requires 1 RU(1.75") of available rackspace.

What you will need:

- 19" Rack case (not included)
- 1 RU of available rack space
- 4 Mounting screws (not included)
- Phillips-head screwdriver (not included)

To mount:

1. Carefully line up the holes on the UHF-6800's rack ears with holes on your rack case.
2. Screw in the mounting screws in an "X" formation to ensure even alignment and tension.

Mounting

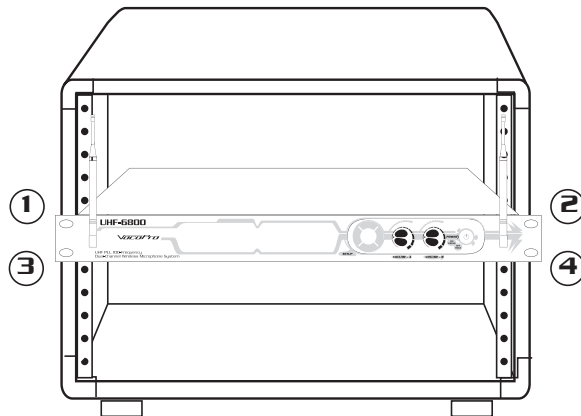

Getting started cont.

Connecting the Antennas

1. Screw on each antennae to the BNC connectors on the front of the UHF-6800. Twist clockwise until it is secure.

Antennas

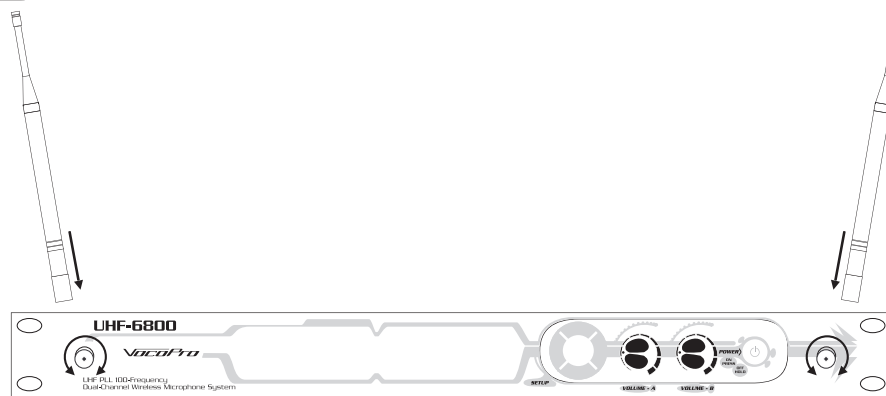

Connecting the AC adapter

Caution: Before connecting the power supply, make sure that the power switch on the receiver is switched OFF.

Note: For additional protection, it is recommended that you plug in the power supply to a surge protector/Power strip.

1. Connect the output end to the AC Power input on the rear panel of the UHF-6800.
 2. Connect the AC adapter to a power outlet.
- NOTE: It is recommended that you connect to a power strip/surge-protector for added protection.*

Installing New Batteries

NOTE: The UHF-6800 requires 2 AA rechargeable batteries.

To install:

1. Slide off the battery compartment cover completely until the battery slots are exposed (Fig. A).
2. Insert both batteries and make sure that their polarities are facing the proper direction (Fig. B).
3. Reattach the battery compartment cover by sliding it back on until it is secure again.

Batteries

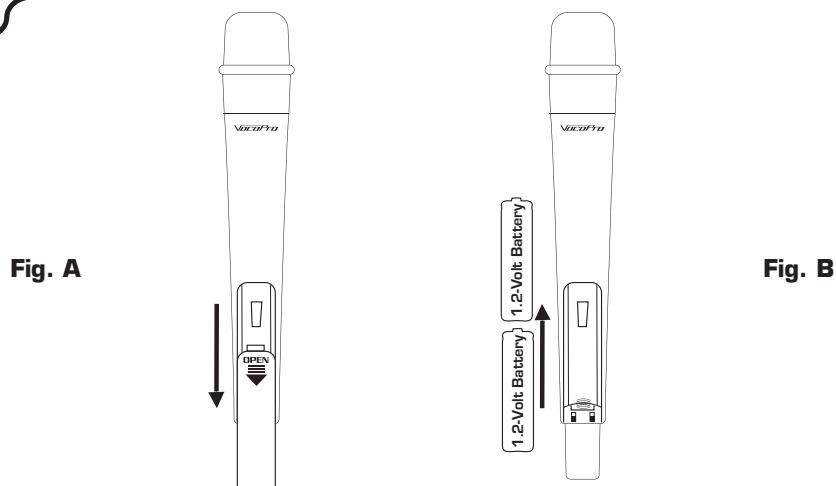

Getting started cont.

Setting Up on Stage

If you will be using the UHF-6800 with stage monitors and/or a P.A. system, try the following:

- Place the stage monitor directly behind the microphone.
- Locate the P.A. loudspeakers so that they point away from the rear of the microphone. (With the speakers located in these positions, the possibility of feedback is greatly reduced).
- Always check the stage setup before a performance to ensure optimum placement of microphone and monitors.

IMPORTANT: Every wireless microphone installation is a unique situation, and can present a variety of problems. Never attempt a live performance without first conducting a "walkthrough" test of the system in the performing area. If major changes (additional wireless systems or intercoms, relocation of scenery, etc.) have been made since the last walk-through test, check the wireless system again, as close to performance time as possible.

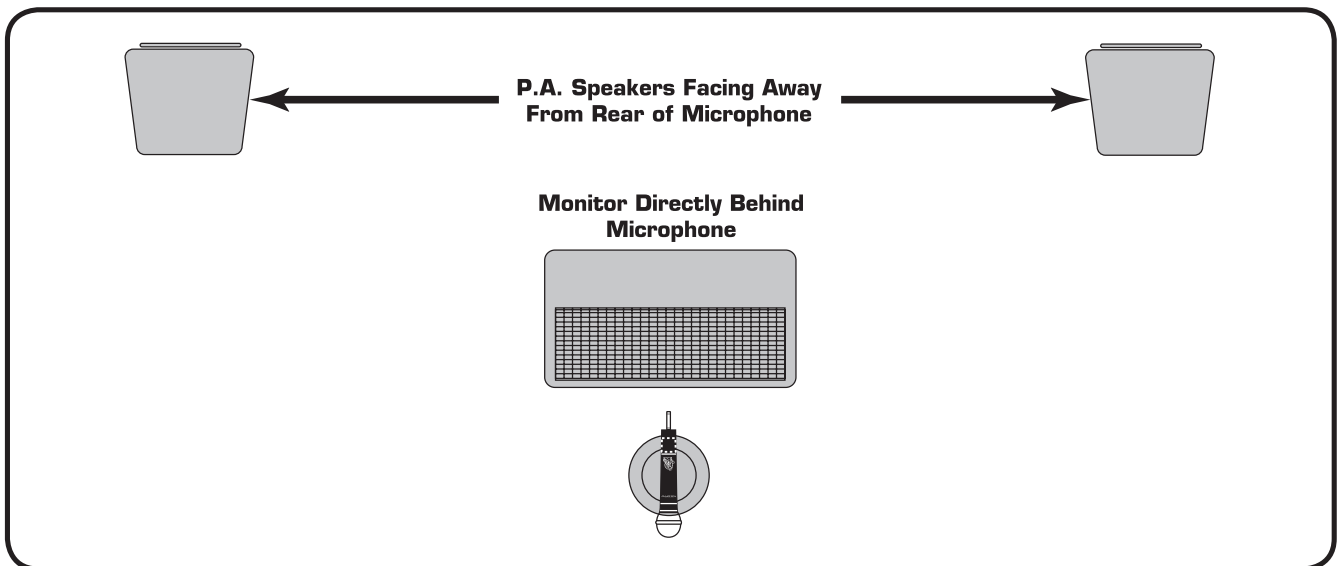

Getting connected

The UHF-6800 gives you two options for outputting vocals

1. Each channel independently using the BALANCED A and B XLR outputs
2. Each channel together using the MIXED 1/4" output

There are a number of ways to integrate the UHF-6800 into your audio system:

Connecting to a Mixer

Connect each mic channel to separate channels on the mixer using the BALANCED XLR outputs (Fig. A) or output both channels to a single input using the MIXED 1/4" output (Fig. B).

Mixer

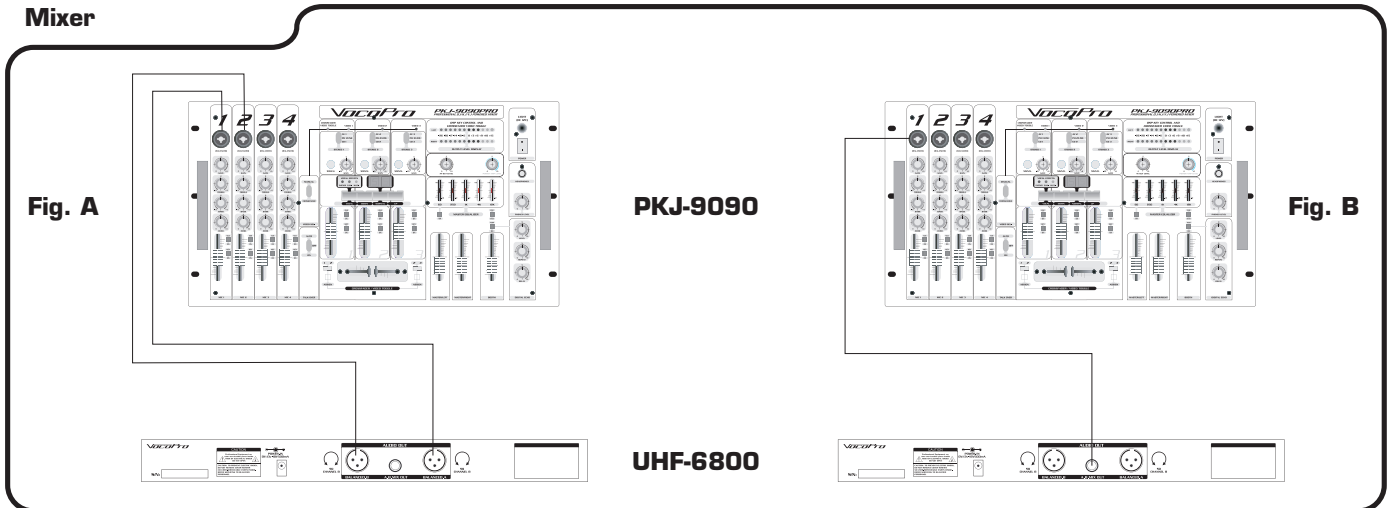

Connecting to an All-In-One System

Using a 1/4" cable, connect the MIXED output to a 1/4" mic input on your all-in-one system.

All-In-One System

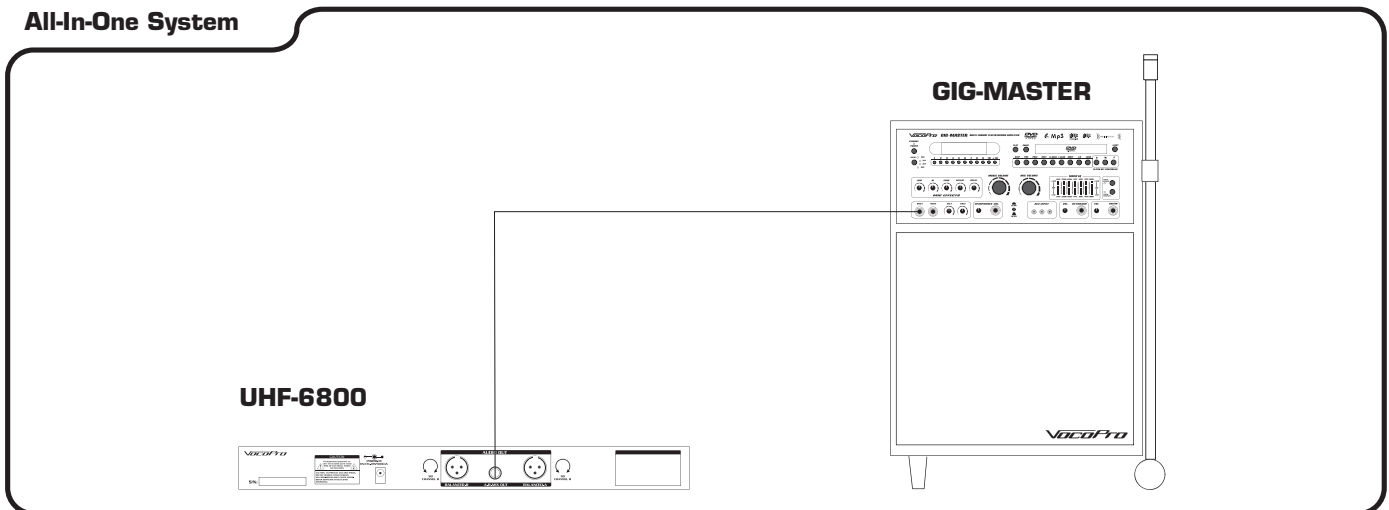

Front panel controls and functions

Front Panel

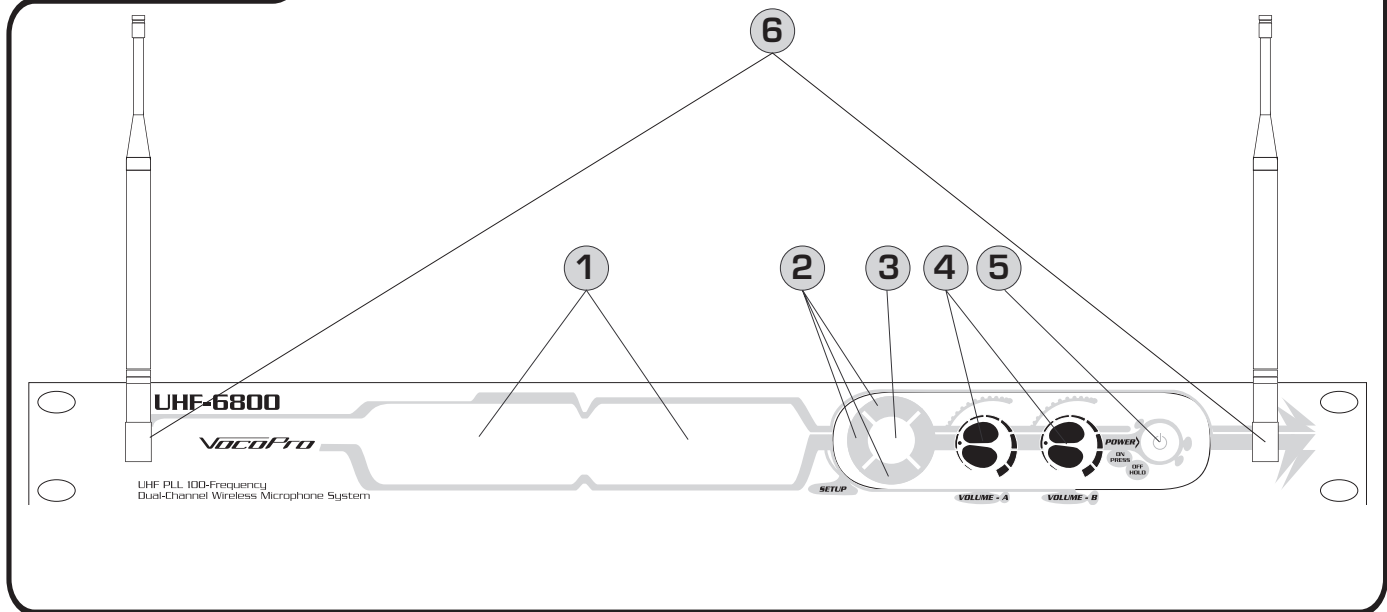

- 1. Display LCD screens** - Displays the Frequency/Channel number and UHF signal strength for each microphone channel.
- 2. Arrow buttons** - Use to navigate through the Frequency/Channel select menu on the receiver, when choosing a frequency for each channel.
- 3. SET button** - Use to make a selection when navigating through the Frequency/Channel select menu on the receiver.
- 4. Volume controls** - Controls the volume for each mic channel. Turn clockwise to raise volume and counter-clockwise to lower the volume.
- 5. Power button** - Turns the UHF-6800's receiver on and off. Press once to turn the receiver on and hold down for 3 seconds to turn the receiver off.
- 6. Antenna connectors** - Connect antennas here. See the "Connecting the Antennas" section for instructions on connecting the antennas.

Rear panel controls and functions

Rear Panel

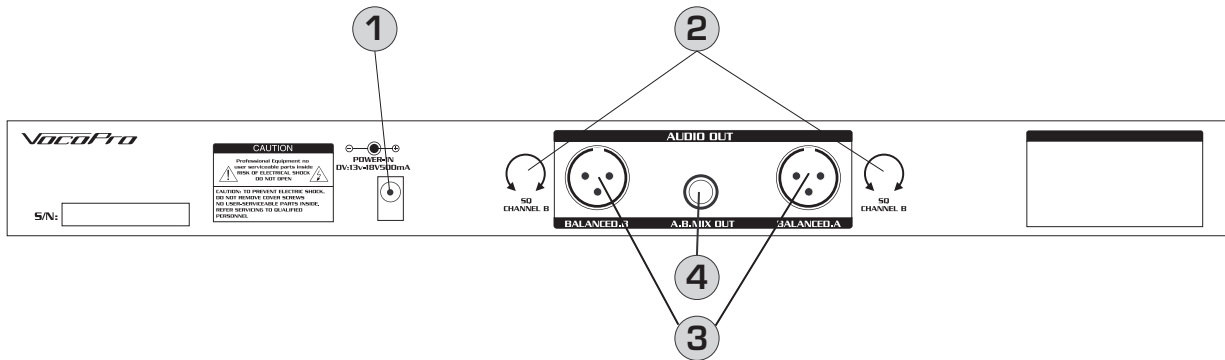

- 1. AC Power jack** - Main power jack for connection to an AC electrical outlet or power strip/surge protector.
- 2. Squelch controls** - Use this to adjust the squelch to limit unwanted interference. See the "Adjusting the Squelch" section of this manual for instructions on when and how to adjust the squelch level.
- 3. Balanced A and B outputs** - Outputs each mic channel independently using a Balanced XLR microphone cable.
- 4. MIXED output** - Outputs both mic channels together using a 1/4" microphone cable.

Microphone control functions

- 1. Grill** - Protects the microphone cartridge and helps reduce "breathy" and wind noise pick-up.
- 2. Display Screen** - Displays the microphone's current Frequency/Channel and the batteries' charge level.
- 3. Up and Down (^ and v) buttons** - Use to navigate through the Frequency/Channel select menu on the microphone, when choosing a frequency.
- 4. 0 (select) button** - Use to make a selection when navigating through the Frequency/Channel select menu on the receiver.
- 5. Power switch** - Turns the microphone on and off. Slide up to turn the mic on and slide down to turn the mic off.
- 6. Battery compartment** - Removable lid hides and protects the microphone battery.
- 7. RF Power HI / LOW switch** - Allows you to set the RF power level. Set to Low when you are in a smaller room and the mic is relatively close to the receiver (i.e. living room and small stage). Set to High, to increase the RF power level when the singer is a farther distance away from the receiver (i.e. large stages and clubs).
- 8. Microphone Lock switch** - Switch On to lock the ^ and v buttons on the mic so that the singer does not accidentally change the frequency while holding the mic. Switch the lock Off when changing the microphone's frequency.

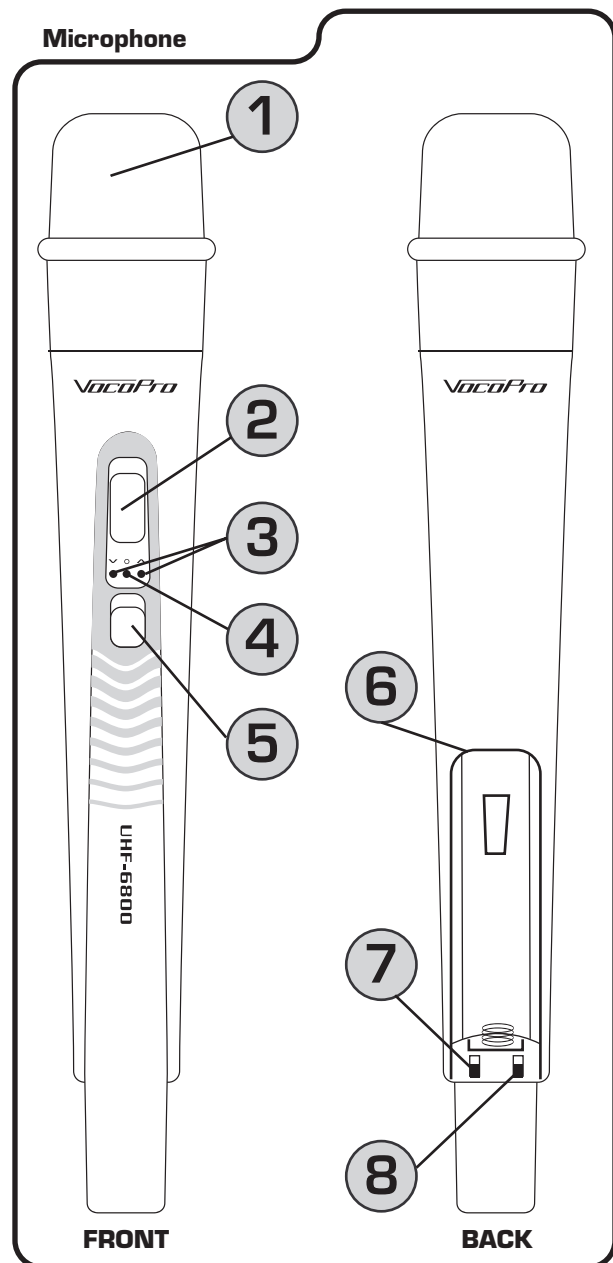

Microphone basics

Microphone Position

The UHF-6800 is ideal for close-up vocals and can be held in the hand or mounted on a mic stand. Keep in mind that microphone technique is largely a matter of personal taste, and there is no one "correct" microphone position.

Feedback

Feedback occurs when the amplified sound from any loudspeaker reenters the sound system through any open microphone and is repeatedly amplified.

Most commonly, feedback is caused by the following conditions:

- Placing loudspeakers too close to microphones,
- Having too many open active microphones
- Boosting tone controls indiscriminately (mainly treble)
- Performing in areas with high ratios of room surfaces that have hard and reflective surfaces such as glass, marble and wood.

What to do if feedback occurs before the sound system is loud enough?

- Request that the talker speak louder into the microphone.
- Reduce the distance from the talker to the microphone. Each time this distance is halved, the sound system output will increase by 6dB.
- Reduce the number of open microphones.
- Move the loudspeaker farther away from the microphone. Each time this distance is doubled, the sound system output can be increased by 6dB.
- Move the loudspeaker closer to the listener.
- Use an equalizer/feedback reducer to cut the frequency bands in which the feedback occurs.

Microphone Placement & Tone Quality

Lead & Backup Vocals

Lips should be less than 3" from or even touching the windscreen on an axis to the microphone. Doing this creates a robust sound, emphasizes bass and provides maximum isolation from other sources.

Speech

When giving a speech or simply speaking, place the microphone 4" to 10" away from the mouth, just above nose height for a natural sound with reduced bass. You can also place the microphone 8" to 16" away from the mouth, slightly off to one side, for a more "distant" sound with highly reduced bass and minimal "s" sounds.

Operations

Turning On/Off the UHF-6800 Receiver

NOTE: Before turning on the UHF-6800's power, be sure that it is plugged into a power source. For maximum protection, use a power strip or surge protector.

To power on:

1. Hold down the POWER button for 2 seconds while the unit is on.

To power off:

1. Hold down the POWER button for 2 seconds

Turning On/Off the UHF-6800 Mic

Slide the power switch to the ON position to turn the mic on and slide it to the OFF position to turn the mic off.

Power Switch

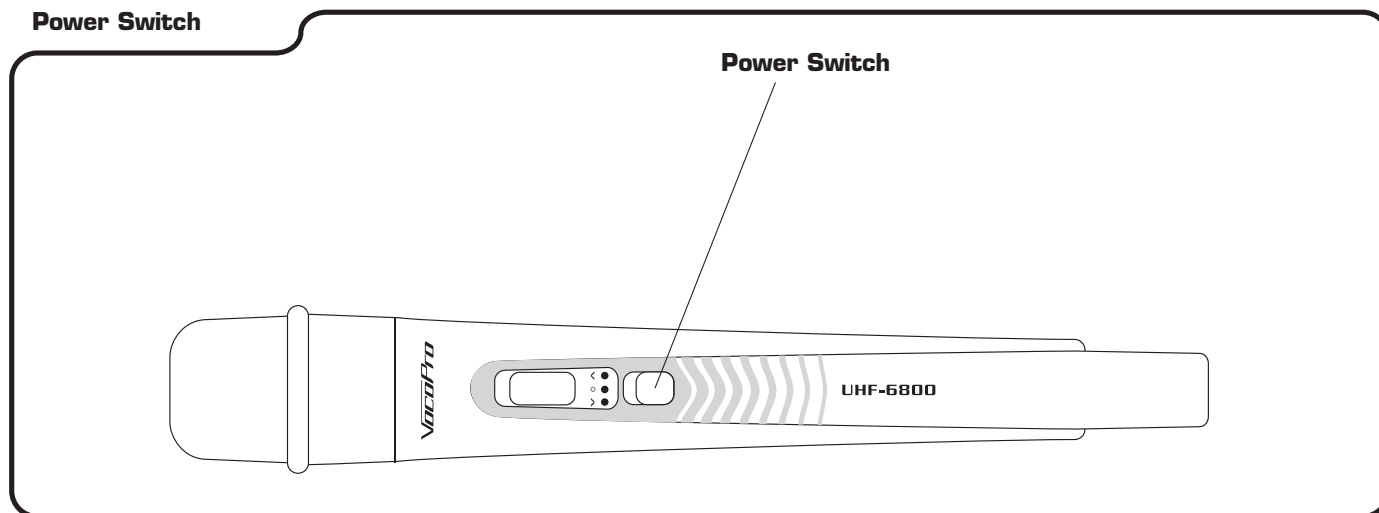

Balancing the Volume

Use the mic volume controls on the front to adjust the balance of the two mic channels. Turn the controls clockwise to raise the volume and counter-clockwise to lower the volume.

Volume Controls

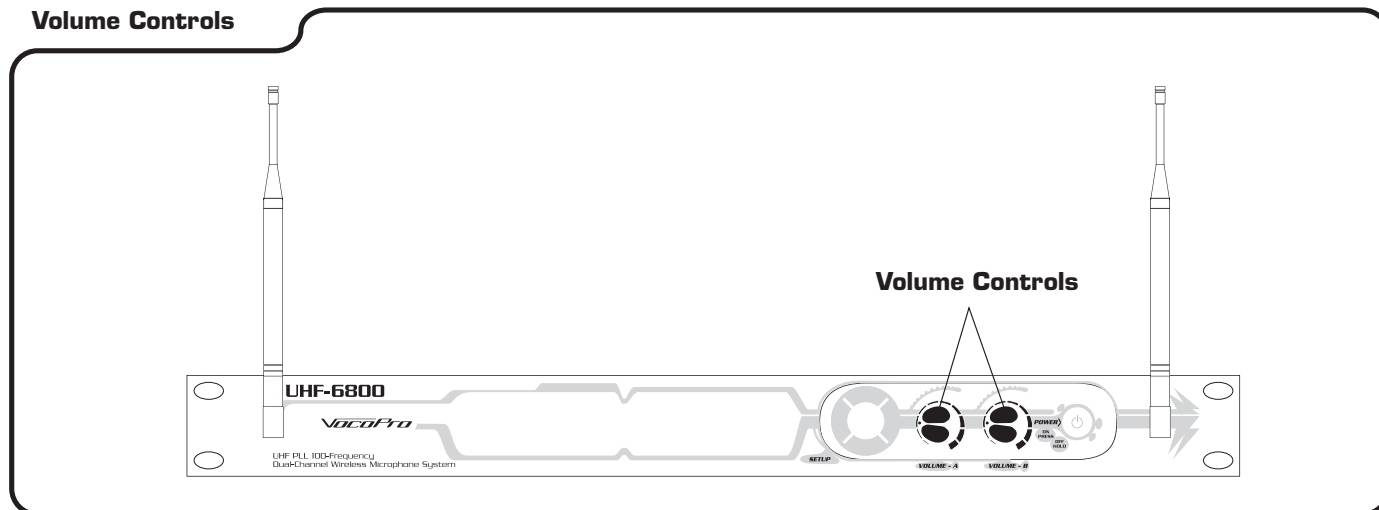

Operations cont.

Selecting a Frequency

NOTES:

- When selecting a frequency, the frequency on the receiver must match the frequency on the mic. Mic Channel A and Mic Channel B must be set to different frequencies.
- Make sure that the LOCK is set to OFF on the microphone and the receiver. See the "Locking the Frequency" section in this manual to lock and unlock the frequency.

Setting the Receiver's frequency

1. Select the mic channel that you are selecting a frequency for; either Microphone Channel A or Microphone Channel B. Press the LEFT arrow button to choose mic channel A or the RIGHT arrow button to choose mic channel B.
2. The LCD screen for the selected mic channel will begin blinking.
3. Use the UP and DOWN arrow buttons to scroll up and down through the 100 different frequencies.
4. When you find the desired frequency, press the SET button to set it as the current frequency for that channel.
5. Now repeat the above steps with the other Mic Channel.

Setting the Microphone's frequency

1. Press the UP and Down buttons on the microphone to scroll through the available frequencies.
2. Press the center circle button on the microphone to select the desired frequency.
3. The number will stop blinking and the frequency will be set.

Changing the Display

The UHF-6800 gives you the option of viewing the actual frequency number or the frequency channel number.

Frequency number: 740.000 - 765.000 in increments of .250

Channel number: Channel 000 - Channel 100

NOTE: The frequency numbers are subject to change and may be different on your UHF-6800

To change the display option on the Receiver

1. Choose which mic channel that you are changing the display for, either Microphone Channel A or Microphone Channel B. Press the LEFT arrow button to choose mic channel A or the RIGHT arrow button to choose mic channel B.
2. The LCD screen for the chosen mic channel will begin blinking.
3. Press the SET button once.
4. The word "DISPLAY" will quickly flash
5. Press the UP arrow button to select "Frequency number" or press the DOWN arrow button to select "Channel number".
6. Press the SET button to set the selection.

To change the display option on the Microphone

1. Press the center circle button once on the microphone.
2. The word DISPL (display) will quickly flash on the microphone's LCD screen
3. Press the UP arrow button to select "Frequency number" or press the DOWN arrow button to select "Channel number".
4. Press the center circle button again to set the display option.

Operations cont.

Frequency

By locking a frequency, you can prevent the user from accidentally changing the frequency.

To lock the frequency on the Receiver

1. Choose which mic channel that you are changing the display for, either Microphone Channel A or Microphone Channel B. Press the LEFT arrow button to choose mic channel A or the RIGHT arrow button to choose mic channel B.
2. The LCD screen for the chosen mic channel will begin blinking.
3. Press the SET button twice.
4. The word "LOCK" will quickly flash.
5. Press the UP arrow button to turn the lock ON or press the DOWN arrow button to turn the lock OFF.
6. Press the SET button to set the selection.

To lock the frequency on the Microphone

1. Slide off the battery compartment cover. The lock switch is located on the lower right hand corner in the battery compartment and is titled LOC (lock).
2. Flip the switch up to turn the lock ON and flip the switch down to turn the lock OFF.

Lock Switch

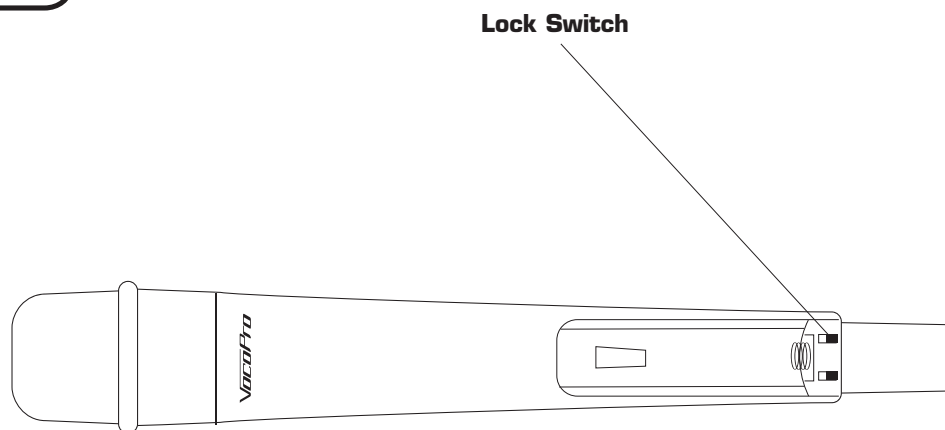

Operations cont.

Adjusting the Squelch

If you are experiencing signal interference, try turning the squelch higher to eliminate unwanted interference signals. Squelch isolates the strongest signals and cuts out the weaker ones.

To adjust the squelch:

1. Using a small flat-head screwdriver, adjust the squelch by turning clockwise to increase it and counter-clockwise to decrease it.

NOTE: Only increase the squelch when absolutely necessary as increasing the squelch may lower the overall volume of the vocals.

Setting the RF Power level

There are two possible settings for the RF Power: High and Low. The RF Power level switch is located inside the battery compartment of each microphone.

To set the RF Power level:

1. Open the battery compartment by sliding off the battery compartment cover.
2. Switch the RF Power Level depending on your set up.

Set the RF Power level to Low for home use, small stages and other situations where the singer is relatively close to the receiver. Set the RF Power level to High when the singer/microphone is further away from the receiver such as on a large stage, large backyard or club.

NOTE: The battery will run out quicker when the RF Power is set to High, so only set to High when necessary.

Squelch/Hi-LOW

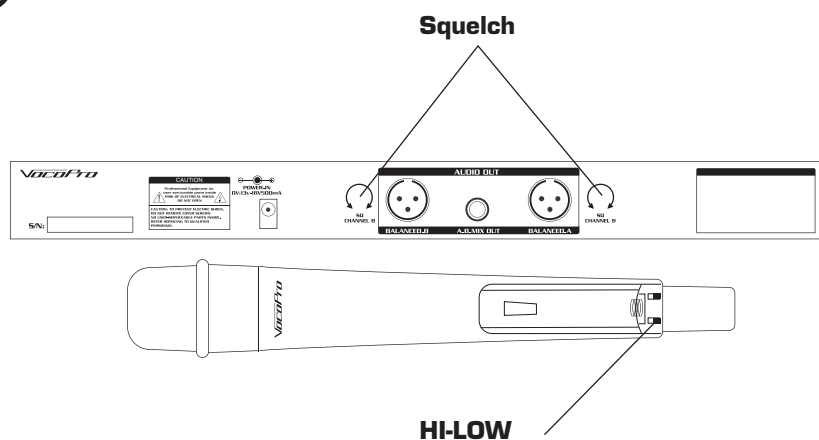

Troubleshooting

No sound output

- Make sure the microphone and receiver power switches are set to the ON position.
- Check microphone batteries to ensure that they are providing sufficient power. Let battery charge or replace if necessary.
- Check receiver's AC power connection.
- Make sure antennas are firmly connected and extended to an optimal position.
- If necessary, reduce the distance between the microphones and receiver.
- Turn up the receiver's VOLUME level controls.
- Check for proper connection between receiver and external amplifier/mixer.
- Talk into the microphone and observe the receiver's signal LED's on the display screen. If they glow, the problem is elsewhere in the sound system.
- Make sure the mic and its corresponding receiver channel are set to the same frequency.

Received signal is noisy or contains extraneous sounds with the microphone(s) ON

- Check microphone(s) batteries and recharge or replace if the charge is low.
- Remove local sources of UHF interference, such as lighting equipment.
- Signal may be too weak. If so, reposition antennas. If possible, move them closer to the transmitter.
- Try increasing the "Squelch" in the receiver
- Try setting the RF Power Level to HIGH. The RF Power Level switch is located inside the battery compartment of each microphone. See the instructions for "Setting the RF Power Level" in this manual.

There is noise coming from the receiver with the microphones turned OFF

- Remove local sources of UHF interference, such as lighting equipment.
- Reposition the receiver or antennas.

Momentary loss of sound as microphone(s) are moved throughout the operating range

- Reposition the receiver, perform a "walkthrough", and observe the signal strengths. If audio dropouts persist, mark these "dead spots" in the operating area and avoid them during the performance.

Battery running low even after recharging

- Replace rechargeable batteries (rechargeable batteries have a life of 500 hours of charging and recharging).

The Mic is switched on and the mic's display screen is on but there is no sound

- Make sure the mic and its corresponding receiver channel are set to the same frequency.
- Make sure the volume on the receiver is turned up.

The microphone is switched on but its display screen is not on

- Replace or recharge the mic's batteries

The vocals become weaker as I walk further away from the receiver

- Switch the RF Power Level to HIGH. The RF Power Level switch is located inside the battery compartment of each microphone. See the instructions for "Setting the RF Power Level" in this manual.

VocoPro[®]

THE SINGER'S ULTIMATE CHOICE[™]



© VOCOPRO 2006
Version 1.0
www.vocopro.com

Free Manuals Download Website

<http://myh66.com>

<http://usermanuals.us>

<http://www.somanuals.com>

<http://www.4manuals.cc>

<http://www.manual-lib.com>

<http://www.404manual.com>

<http://www.luxmanual.com>

<http://aubethermostatmanual.com>

Golf course search by state

<http://golfingnear.com>

Email search by domain

<http://emailbydomain.com>

Auto manuals search

<http://auto.somanuals.com>

TV manuals search

<http://tv.somanuals.com>