

DO NOT REMOVE

FILE COPY

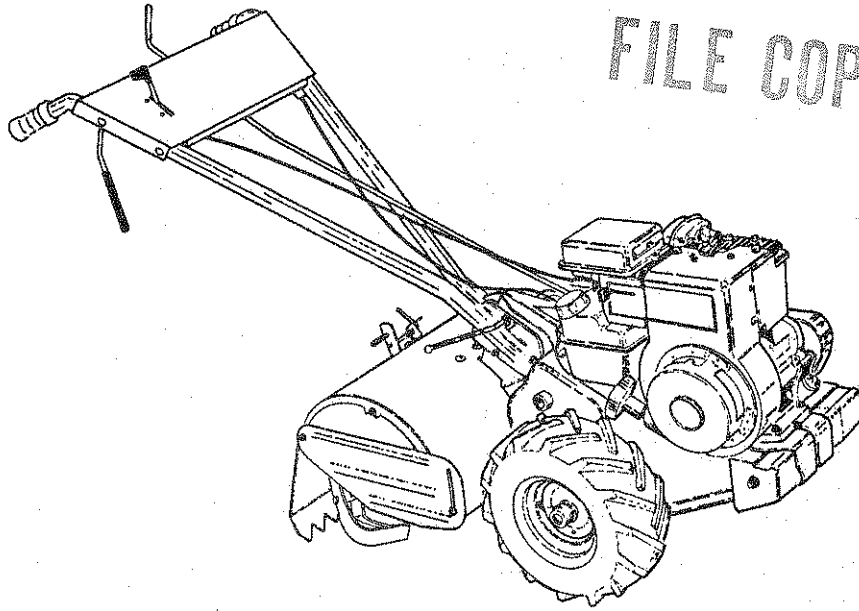

**OWNER'S MANUAL**  
**Model No. WER500A**  
**5 HP 17 Inch**  
**Rear Tine Tiller**

- Assembly
- Operation
- Service and Adjustments
- Customer Responsibilities
- Storage

---

**WEED EATER®**



# SAFETY RULES



## Safe Operation Practices for Walk-Behind Powered Rotary Tillers

### TRAINING

- Read the Owner's Manual carefully. Be thoroughly familiar with the controls and the proper use of the equipment. Know how to stop the unit and disengage the controls quickly.
- Never allow children to operate the equipment. Never allow adults to operate the equipment without proper instruction.
- Keep the area of operation clear of all persons, particularly small children, and pets.

### PREPARATION

- Thoroughly inspect the area where the equipment is to be used and remove all foreign objects.
- Disengage all clutches and shift into neutral before starting the engine (motor).
- Do not operate the equipment without wearing adequate outer garments. Wear footwear that will improve footing on slippery surfaces.
- Handle fuel with care; it is highly flammable.
  - Use an approved fuel container.
  - Never add fuel to a running engine or hot engine.
  - Fill fuel tank outdoors with extreme care. Never fill fuel tank indoors.
  - Replace gasoline cap securely and clean up spilled fuel before restarting.
- Use extension cords and receptacles as specified by the manufacturer for all units with electric drive motors or electric starting motors.
- Never attempt to make any adjustments while the engine (motor) is running (except where specifically recommended by manufacturer).

### OPERATION

- Do not put hands or feet near or under rotating parts.
- Exercise extreme caution when operating on or crossing gravel drives, walks, or roads. Stay alert for hidden hazards or traffic. Do not carry passengers.
- After striking a foreign object, stop the engine (motor), remove the wire from the spark plug, thoroughly inspect the tiller for any damage, and repair the damage before restarting and operating the tiller.
- Exercise caution to avoid slipping or falling.

- If the unit should start to vibrate abnormally, stop the engine (motor) and check immediately for the cause. Vibration is generally a warning of trouble.
- Stop the engine (motor) when leaving the operating position.
- Take all possible precautions when leaving the machine unattended. Disengage the tines, shift into neutral, and stop the engine.
- Before cleaning, repairing, or inspecting, shut off the engine and make certain all moving parts have stopped. Disconnect the spark plug wire, and keep the wire away from the plug to prevent accidental starting. Disconnect the cord on electric motors.
- Do not run the engine indoors; exhaust fumes are dangerous.
- Never operate the tiller without proper guards, plates, or other safety protective devices in place.
- Keep children and pets away.
- Do not overload the machine capacity by attempting to till too deep at too fast a rate.
- Never operate the machine at high speeds on slippery surfaces. Look behind and use care when backing.
- Never allow bystanders near the unit.
- Use only attachments and accessories approved by the manufacturer of the tiller (such as wheel weights, counterweights, cabs, and the like).
- Never operate the tiller without good visibility or light.
- Be careful when tilling in hard ground. The tines may catch in the ground and propel the tiller forward. If this occurs, let go of the handlebars and do not restrain the machine.

### MAINTENANCE AND STORAGE

- Keep machine, attachments, and accessories in safe working condition.
- Check shear pins, engine mounting bolts, and other bolts at frequent intervals for proper tightness to be sure the equipment is in safe working condition.
- Never store the machine with fuel in the fuel tank inside a building where ignition sources are present, such as hot water and space heaters, clothes dryers, and the like. Allow the engine to cool before storing in any enclosure.
- Always refer to the operator's guide instructions for important details if the tiller is to be stored for an extended period.

### - IMPORTANT -

CAUTION, IMPORTANTS, AND NOTES ARE A MEANS OF ATTRACTING ATTENTION TO IMPORTANT OR CRITICAL INFORMATION IN THIS MANUAL.



**CAUTION:** Look for this symbol to point out important safety precautions. It means —Attention! Become Alert! Your safety is involved.

**IMPORTANT:** USED TO ALERT YOU THAT THERE IS A POSSIBILITY OF DAMAGING THIS EQUIPMENT.

**NOTE:** Gives essential information that will aid you to better understand, incorporate, or execute a particular set of instructions.

**CONGRATULATIONS** on your purchase of a new tiller. It has been designed, engineered and manufactured to give you the best possible dependability and performance.

Should you experience any problems you cannot easily remedy, please contact your nearest authorized service center. We have competent, well-trained technicians and the proper tools to service or repair this unit.

Please read and retain this manual. The instructions will enable you to assemble and maintain your tiller properly. Always observe the "SAFETY RULES".

MODEL  
NUMBER **WER500A**

SERIAL  
NUMBER \_\_\_\_\_

DATE OF  
PURCHASE \_\_\_\_\_

THE MODEL AND SERIAL NUMBERS WILL BE FOUND ON THE MODEL PLATE ATTACHED TO THE TOP OF THE TRANSMISSION.

YOU SHOULD RECORD BOTH SERIAL NUMBER AND DATE OF PURCHASE AND KEEP IN A SAFE PLACE FOR FUTURE REFERENCE.

## PRODUCT SPECIFICATIONS

HORSEPOWER:	5.0 HP
DISPLACEMENT:	12.57 cu. in. (206 cc)
GASOLINE CAPACITY:	3 Quarts (2.8L) Unleaded Regular
OIL : (CAPACITY: 20 oz. [0.6L])	SAE 30W (Above 32°F/0°C) SAE 5W-30 (Below 32°F/0°C)
SPARK PLUG : (GAP: .030" [0.76mm])	Champion RJ19LM

## CUSTOMER RESPONSIBILITIES

- Read and observe the safety rules.
- Follow a regular schedule in maintaining, caring for and using your tiller.
- Follow instructions under "Customer Responsibilities" and "Storage" sections of this Owner's Manual.

**IMPORTANT:** THIS UNIT IS EQUIPPED WITH AN INTERNAL COMBUSTION ENGINE AND SHOULD NOT BE USED ON OR NEAR ANY UNIMPROVED FOREST-COVERED, BRUSH-COVERED OR GRASS COVERED LAND UNLESS THE ENGINE'S EXHAUST SYSTEM IS EQUIPPED WITH A SPARK ARRESTER MEETING APPLICABLE LOCAL LAWS (IF ANY). IF A SPARK ARRESTER IS USED, IT SHOULD BE MAINTAINED IN EFFECTIVE WORKING ORDER BY THE OPERATOR. SEE YOUR AUTHORIZED SERVICE CENTER FOR SPARK ARRESTER.

## LIMITED WARRANTY

The Manufacturer warrants to the original consumer purchaser that this product as manufactured is free from defects in materials and workmanship. For a period of two (2) years from date of purchase by the original consumer purchaser, we will repair or replace, at our option, without charge for parts or labor incurred in replacing parts, any part which we find to be defective due to materials or workmanship. This Warranty is subject to the following limitations and exclusions.

1. This warranty does not apply to the engine or components parts thereof. Please refer to the applicable manufacturer's warranty on these items.
2. Transportation charges for the movement of any power equipment unit or attachment are the responsibility of the purchaser. Transportation charges for any parts submitted for replacement under this warranty must be paid by the purchaser unless such return is requested by American Yard Products, Inc.
3. The Warranty period for any products used for rental or commercial purposes is limited to 90 days from the date of original purchase.
4. This Warranty applies only to products which have been properly assembled, adjusted, operated, and maintained in accordance with the instructions furnished. This Warranty does not apply to any product which has been subjected to alteration, misuse, abuse, improper assembly or installation, delivery damage, or to normal wear of the product.
5. Exclusions: Excluded from this Warranty are belts, tines, tine adapters, normal wear, normal adjustments, standard hardware and normal maintenance.
6. In the event you have a claim under this Warranty, you must return the product to an authorized service dealer.

Should you have any unanswered questions concerning this Warranty, please contact:

In U.S.A. contact:

American Yard Products, Inc.  
Service Department  
P.O. Box 370  
McRae, GA 31055

In Canada contact:

AYP Canada, Inc.  
1040 Jayson Court  
Mississauga, Ontario  
L4W 2V5

International contact:

American Yard Products, Inc.  
Service Department  
P.O. Box 1687  
Orangeburg, SC 29116 USA

giving the model number, serial number and date of purchase of your product and the name and address of the authorized dealer from whom it was purchased.

THIS WARRANTY DOES NOT APPLY TO INCIDENTAL OR CONSEQUENTIAL DAMAGES AND ANY IMPLIED WARRANTIES ARE LIMITED TO THE SAME TIME PERIODS STATED HEREIN FOR OUR EXPRESSED WARRANTIES. Some areas do not allow the limitation of consequential damages or limitations of how long an implied Warranty may last, so the above limitations or exclusions may not apply to you. This Warranty gives you specific legal rights, and you may have other rights which vary from locale to locale.

This is a limited Warranty within the meaning of that term as defined in the Magnuson-Moss Act of 1975.

# TABLE OF CONTENTS

SAFETY RULES .....	2	MAINTENANCE SCHEDULE .....	13
CUSTOMER RESPONSIBILITIES .....	3,13-15	SERVICE & ADJUSTMENTS .....	15-18
PRODUCT SPECIFICATIONS .....	3	STORAGE .....	19
WARRANTY .....	3	TROUBLESHOOTING .....	20
ASSEMBLY .....	5-7	REPAIR PARTS-TILLER .....	21-26
OPERATION .....	8-12		

## INDEX

<b>A</b>		Engine (cont'd)		<b>R</b>	
Adjustments:		Lubrication .....	14	Repair Parts .....	21-26
Depth Stake .....	9	Oil Level .....	10	Rules for Safe Operation .....	2
Handle Height .....	15	Oil Type .....	10,14	<b>S</b>	
Side Shields .....	10	Spark Plug .....	15	Service & Adjustments:	
Throttle .....	18	Starting .....	11	Handle Height .....	15
Tines .....	17	Stopping .....	9	Side Shields .....	10
V-Belt (Ground Drive) .....	16	Storage .....	19	Throttle .....	18
Wheels .....	12,15	Winter Operation .....	14	Tines .....	17
Air Cleaner .....	14			V-Belt (Ground Drive) .....	16
				Wheels .....	12,15
<b>B</b>		<b>F</b>		Service:	
Belt:		Fuel:		Repair Parts .....	21-26
Belt Guard .....	16	Filling Tank .....	10	Service Record .....	13
Repair Parts .....	22	Storage .....	19	Shear Pins:	
V-Belt (Ground Drive) .....	16	Type .....	10	Operation .....	11
		Finish:		Repair Parts .....	26
<b>C</b>		Maintenance .....	15	Spark Plug:	
Cooling System .....	14			Gap .....	3
Controls:		<b>H</b>		Maintenance .....	15
Choke .....	8	Handle:		Storage:	
Throttle .....	8	Height Adjustment .....	15	Fuel System .....	19
Tines .....	8	Repair Parts .....	21	Tiller .....	19
Cultivating .....	12			<b>T</b>	
Customer Responsibilities:		<b>L</b>		Tilling .....	9,11
Air Cleaner .....	14	Lubrication:		Tines:	
Cooling System .....	14	Lubrication Chart .....	13	Arrangement/Replacement .....	17
Finish .....	15	Engine .....	14	Operation .....	9
Maintenance Schedule .....	13			Repair Parts .....	26
Muffler .....	15	<b>M</b>		Shear Pins .....	11
Oil Change .....	14	Muffler:		Transmission:	
Spark Plug .....	15	Maintenance .....	15	Maintenance .....	15
Tines .....	17	Spark Arrester .....	3	Repair Parts .....	24
Transmission .....	15			Troubleshooting .....	20
V-Belt (Ground Drive) .....	16	<b>O</b>		Transporting .....	10
		Oil:		<b>W</b>	
<b>D</b>		Level .....	10	Warranty .....	3
Depth Stake:		Type .....	10,14	Wheels:	
Adjustment .....	9	Operation:		Adjustments .....	12
Repair Parts .....	25	Cultivating .....	12	Removal .....	15
		Fill Fuel Tank .....	10	Repair Parts .....	23
<b>E</b>		Starting Engine .....	11		
Engine:		Stopping Tines & Engine .....	9		
Air Cleaner .....	14	Tilling .....	9		
Cooling System .....	14	Tilling Hints .....	11		
Fuel Type .....	10	Tine Operation .....	9		
		Transporting Tiller .....	10		
		Winter Operation .....	14		

# ASSEMBLY

## TO ASSEMBLE YOUR TILLER YOU WILL NEED:

- (1) Utility knife
- (1) Tire pressure gauge
- (1) Pair of pliers
- (1) 9/16" wrench (or adjustable wrench)
- (1) 7/16" wrench (or adjustable wrench)

## OPERATOR'S POSITION (See Fig. 1)

The right hand (R.H.) and left hand (L.H.) sides of your tiller are determined from the operator's position while standing behind tiller.

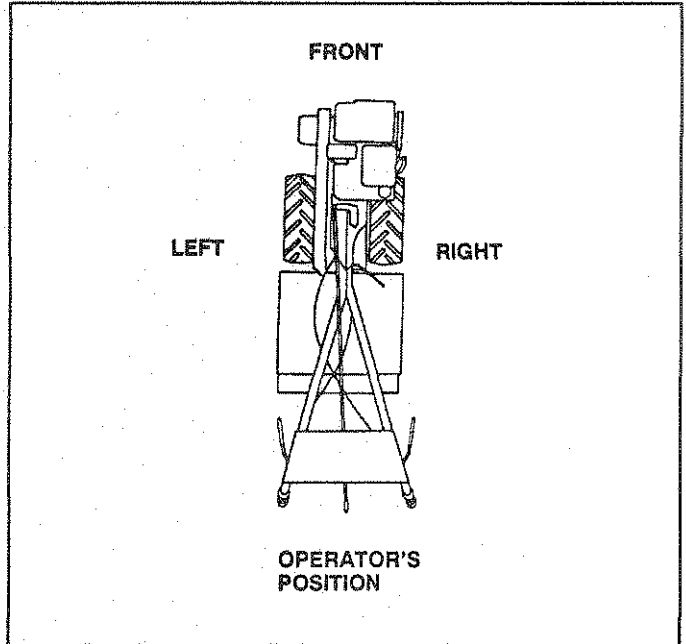
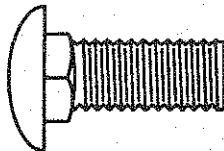

FIG. 1

## CONTENTS OF HARDWARE PACK



(2) Handle Locks



(2) Carriage Bolts 3/8-16 UNC x 1 Gr. 5

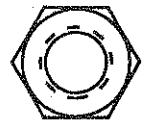

(2) Center Locknuts 3/8-16 UNC

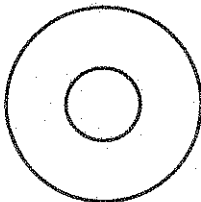

(1) Flat Washer 13/32 x 1 x 11 Ga.

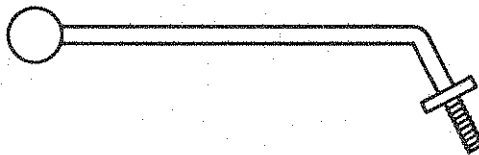

(1) Handle Lock Lever



(1) Hairpin Clip

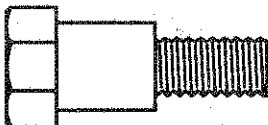

(1) Shoulder Bolt



(1) Lock Washer 1/4



(1) Hex Nut 1/4-20

# ASSEMBLY

## UNPACKING CARTON (See Fig. 2)



**CAUTION:** Be careful of exposed staples when handling or disposing of cartoning material.

**IMPORTANT:** WHEN UNPACKING AND ASSEMBLING TILLER, BE CAREFUL NOT TO STRETCH OR KINK CABLES.

- While holding handle assembly, cut cable ties securing handle assembly to top frame and depth stake. Let handle assembly rest on tiller.
- Remove top frame of carton.
- Slowly ease handle assembly up and place on top of carton.
- Cut down right hand front and right hand rear corners of carton, lay side carton wall down.
- Remove packing material from handle assembly.
- Separate shift rod from handle assembly.

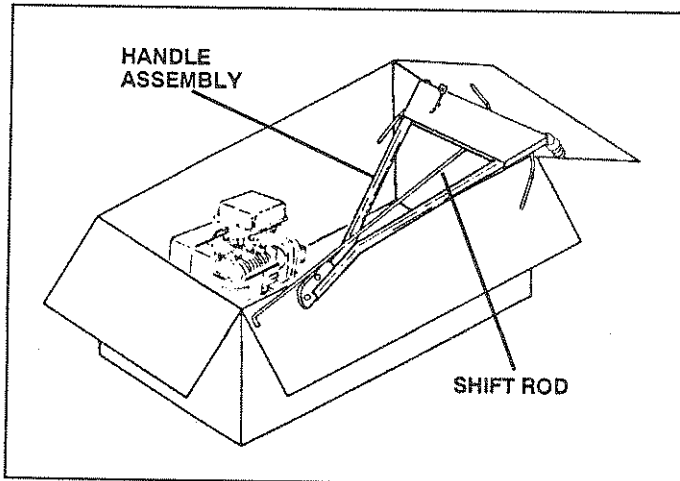

FIG. 2

## INSTALL HANDLE (See Figs. 3, 4, and 5)

- Insert one handle lock (with teeth facing outward) in gearcase notch. (Apply grease on smooth side of handle lock to aid in keeping lock in place until handle assembly is lowered into position.)

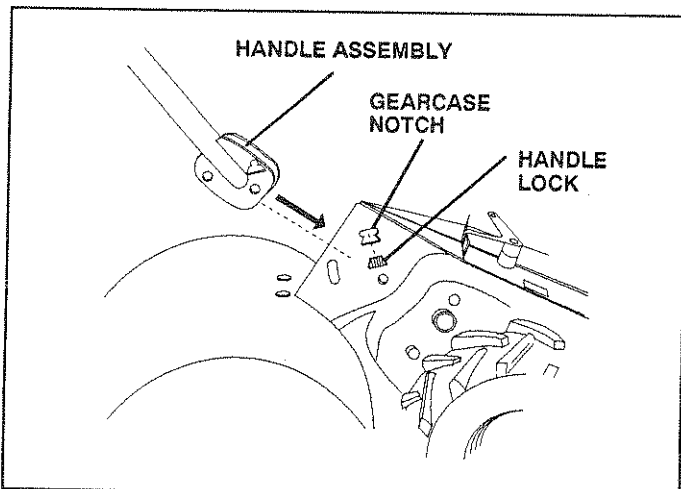

FIG. 3

- Grasp handle assembly. Hold in "up" position. Be sure handle lock remains in gearcase notch. Slide handle assembly into position.

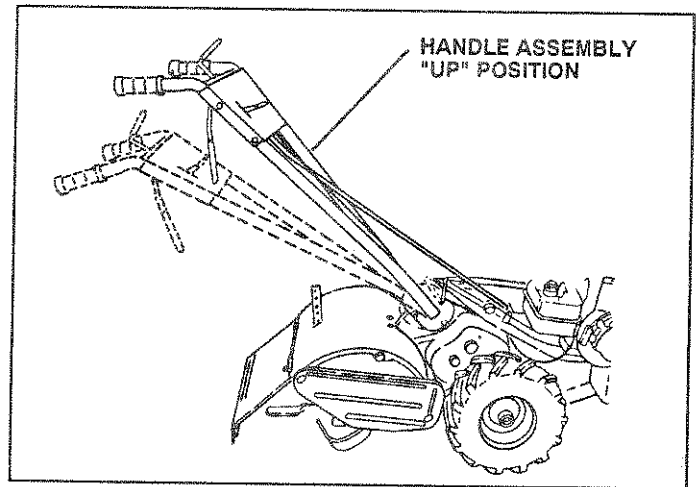

FIG. 4

- Rotate handle assembly down to install two carriage bolts and locknuts. Insert rear carriage bolt (Fig. 5) first, with head of bolt on L.H. side of tiller. Lower the handle assembly. Tighten bolts so handle moves with some resistance.
- Insert second handle lock (with teeth inward) in the slot of the handle base.
- Place flat washer on threaded end of handle lock lever.
- Insert handle lock lever through handle base and gearcase.
- With handle assembly in lowest position, securely tighten handle lock lever by rotating clockwise. Leaving handle assembly in lowest position will make it easier to remove tiller from carton.

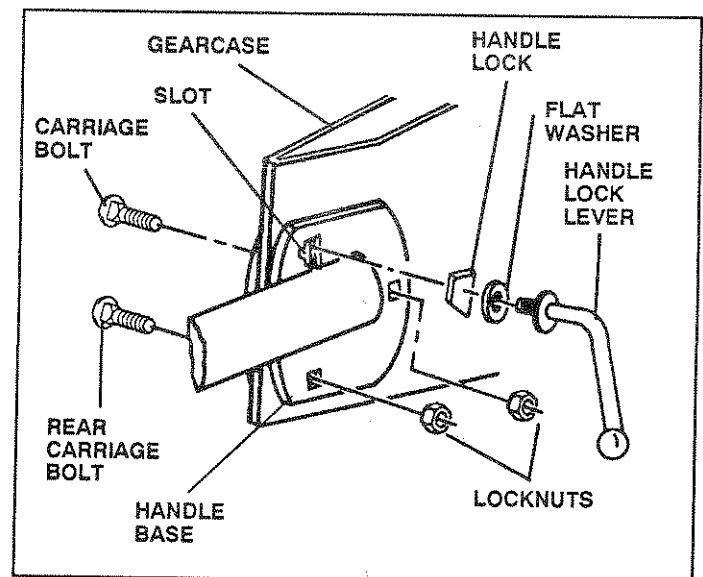

FIG. 5

# ASSEMBLY

## CONNECT SHIFT ROD (See Fig. 6)

- Insert end of shift rod farthest from bend into hole of shift lever indicator.
- Insert hairpin clip through hole of shift rod to secure.

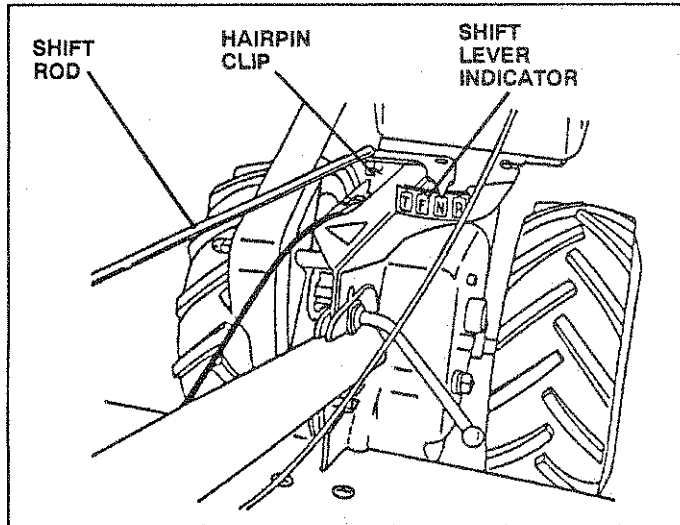

FIG. 6

## REMOVE TILLER FROM CRATE

- Make sure shift lever indicator is in "N" position (See Fig. 6)
- Tilt tiller forward by lifting handle. Separate cardboard cover from leveling shield.
- Rotate tiller handle to the right and pull tiller out of carton.

## ATTACH CLUTCH CABLE (See Fig. 7)

- Place shoulder bolt through looped end of clutch cable and through hole of control bar assembly bracket.
- Assemble 1/4" lock washer and nut and tighten securely.

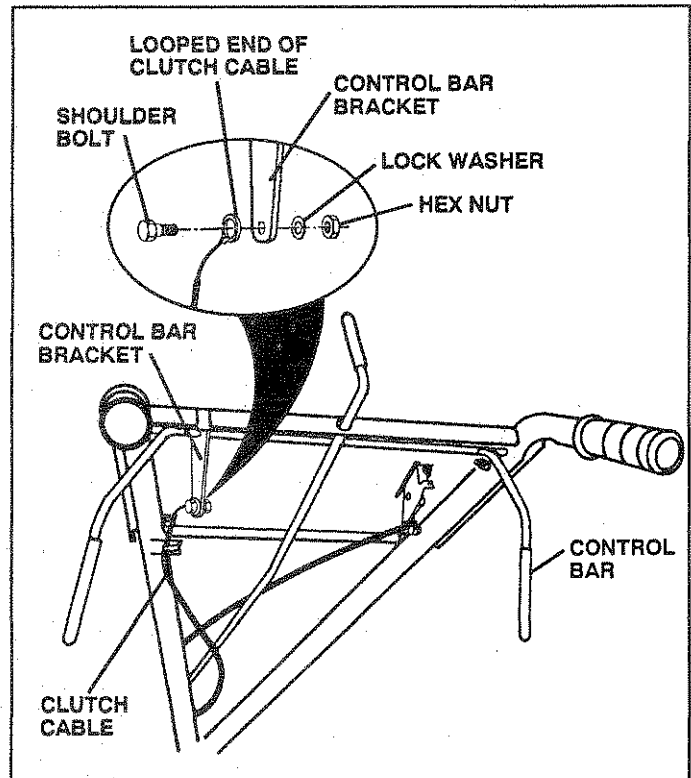

FIG. 7

## CHECK TIRE PRESSURE

The tires on your unit were overinflated at the factory for shipping purposes. Correct and equal tire pressure is important for best tilling performance.

- Reduce tire pressure to 20 PSI (1.4 kg/cm<sup>2</sup>).

## HANDLE HEIGHT

- Handle height may be adjusted to better suit operator. (See "TO ADJUST HANDLE HEIGHT" in the Service and Adjustments section of this manual).

# OPERATION

## KNOW YOUR TILLER

READ THIS OWNER'S MANUAL AND SAFETY RULES BEFORE OPERATING YOUR TILLER.

Compare the illustrations with your tiller to familiarize yourself with the location of various controls and adjustments. Save this manual for future reference.

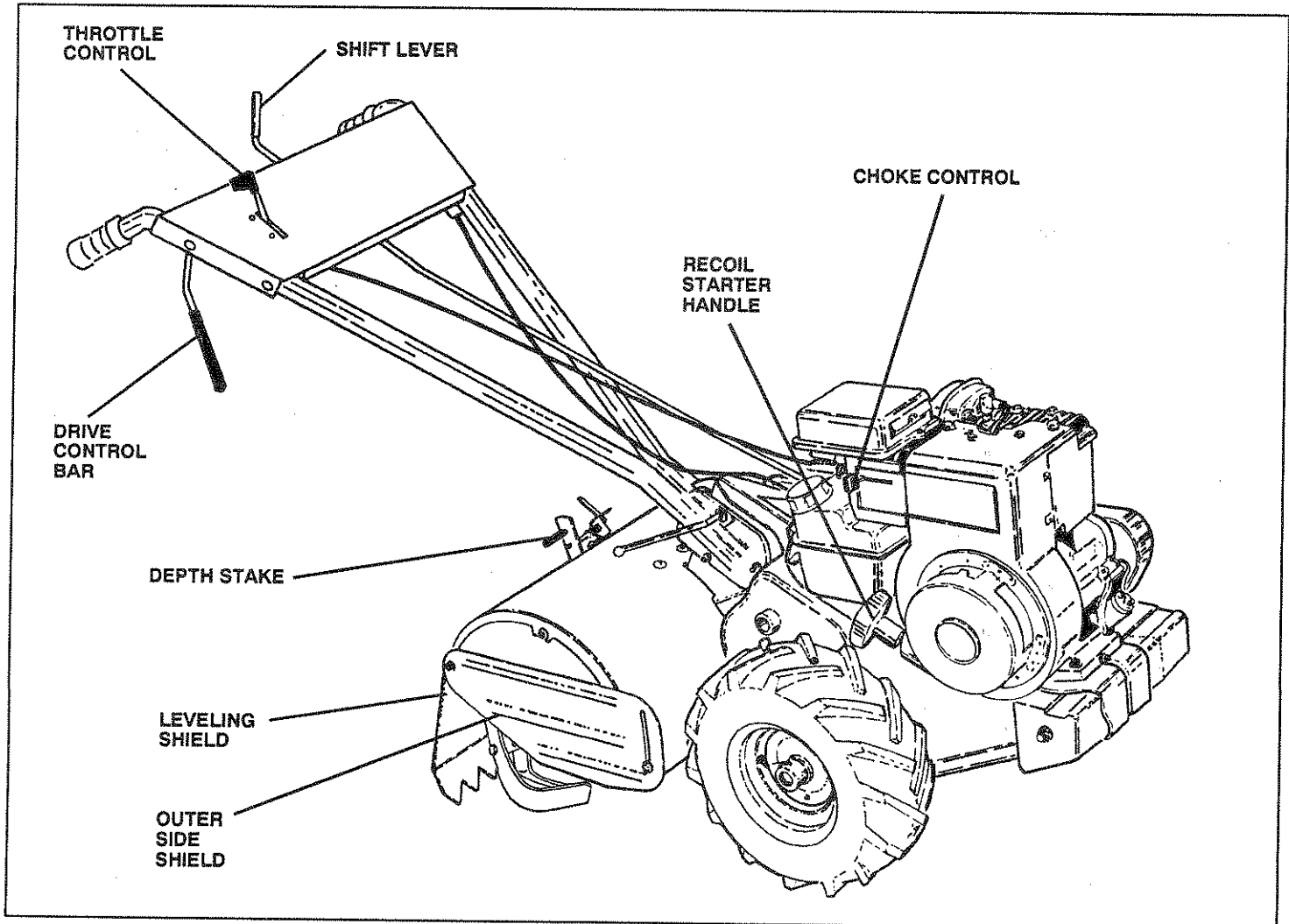

FIG. 8

## MEETS ANSI SAFETY REQUIREMENTS

Our tillers conform to the safety standards of the American National Standards Institute.

**THROTTLE CONTROL** - Used to control engine speed.  
**DRIVE CONTROL BAR** - Used to engage tiller.  
**DEPTH STAKE** - Controls depth at which tiller will dig.  
**LEVELING SHIELD** - Levels tilled soil.

**OUTER SIDE SHIELD** - Adjustable to protect small plants from being buried.  
**SHIFT LEVER** - Used to shift transmission gears.  
**RECOIL STARTER HANDLE** - Used to start the engine.  
**CHOKE CONTROL** - Used when starting a cold engine.



# OPERATION



The operation of any tiller can result in foreign objects thrown into the eyes, which can result in severe eye damage. Always wear safety glasses or eye shields before starting your tiller and while tilling. We recommend wide vision safety mask for over the spectacles or standard safety glasses.

## HOW TO USE YOUR TILLER

Know how to operate all controls before adding fuel and oil or attempting to start engine.

### STOPPING (See Fig. 9)

#### TINES AND DRIVE

- Release drive control bar to stop movement.
- Move shift lever to "N" (neutral) position.

#### ENGINE

- Move throttle control to "STOP" position.
- Never use choke to stop engine.

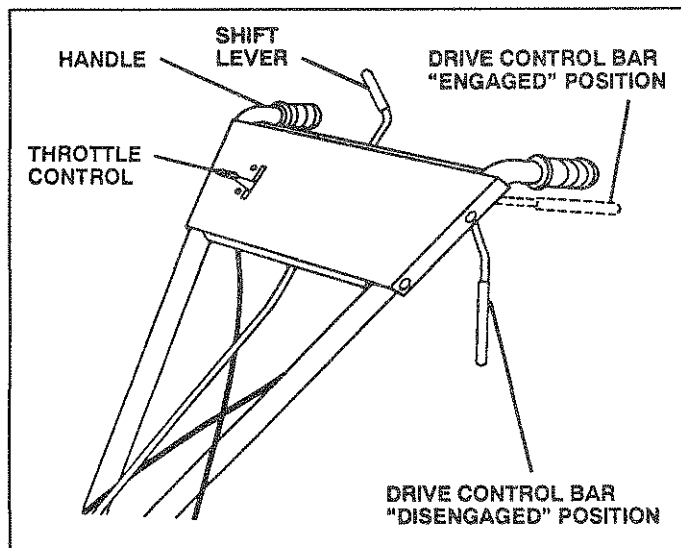

FIG. 9

### TINE OPERATION - WITH WHEEL DRIVE

- Always release drive control bar before moving shift lever into another position.
- Tine movement is achieved by moving shift lever to "T" (till) position and engaging drive control bar.

### FORWARD - WHEELS ONLY/TINES STOPPED

- Release drive control bar and move shift lever indicator to "F" (forward) position. Engage drive control bar and tiller will move forward.

### REVERSE - WHEELS ONLY/TINES STOPPED

- DO NOT STAND DIRECTLY BEHIND TILLER.
- Release the drive control bar.
- Move throttle control to "SLOW" position.
- Move shift lever indicator to "R" (reverse) position.
- Hold drive control bar against the handle to start tiller movement.

### DEPTH STAKE (See Fig. 10)

The depth stake can be raised or lowered to allow you more versatile tilling and cultivating, or to more easily transport your tiller.

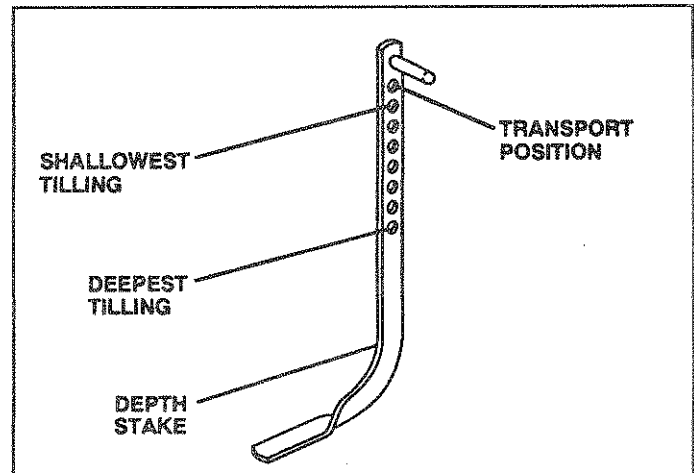

FIG. 10

### TILLING (See Fig. 11)

- Release depth stake pin. Pull the depth stake up for increased tilling depth. Place depth stake pin in hole of depth stake to lock in position.
- Place shift lever indicator in "T" position.
- Hold the drive control bar against the handle to start tilling movement. Tines and wheels will both turn.
- Move throttle control to "FAST" position for deep tilling. To cultivate, throttle control can be set at any desired speed, depending on how fast or slow you wish to cultivate.

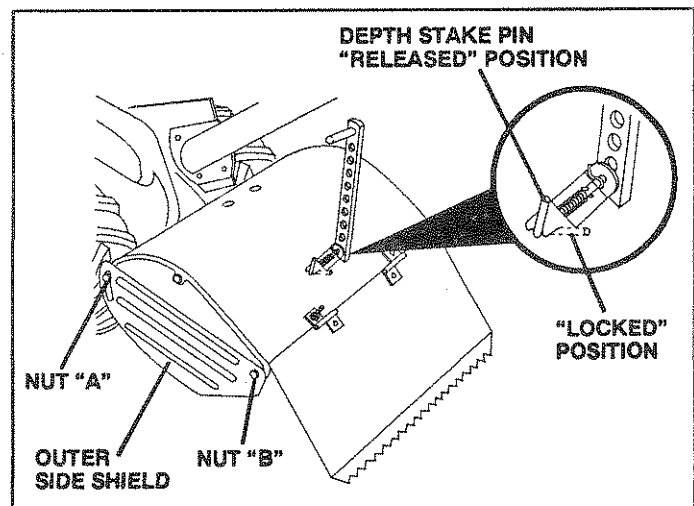

FIG. 11

# OPERATION

## TURNING

- Release the drive control bar.
- Move throttle control to "SLOW" position.
- Place shift lever indicator in "F" (forward) position. Tines will not turn.
- Lift handle to raise tines out of ground.
- Swing the handle in the opposite direction you wish to turn, being careful to keep feet and legs away from tines.
- When you have completed your turn-around, release the drive control bar and lower handle. Place shift lever in "T" (till) position and move throttle control to desired speed. To begin tilling, hold drive control bar against the handle.

## OUTER SIDE SHIELDS (See Fig. 11)

The front edges of the outer side shields are slotted so that the shields can be raised for deep tilling and lowered for shallow tilling to protect small plants from being buried. Loosen nut "A" in slot and nut "B". Move shield to desired position (both sides). Retighten nuts.

## TRANSPORTING



**CAUTION:** Before lifting or transporting, allow tiller engine and muffler to cool. Disconnect spark plug wire. Drain gasoline from fuel tank.

- Release the depth stake pin. Move the depth stake down to the top hole for transporting the tiller. Place depth stake pin in hole of depth stake to lock in position. This prevents tines from scuffing the ground.
- Place shift lever indicator in "F" (forward) position for transporting.
- Hold the drive control bar against the handle to start tiller movement. Tines will not turn.
- Move throttle control to desired speed.



**CAUTION:** Before operating your tiller for the first time, study this section and the "SAFETY RULES" on page 2.

Always release drive control bar before moving shift lever into another position.

Don't back yourself into a solid obstruction such as a tree, fence, etc.

## BEFORE STARTING ENGINE

**IMPORTANT:** BE VERY CAREFUL NOT TO ALLOW DIRT TO ENTER THE ENGINE WHEN CHECKING OR ADDING OIL OR FUEL. USE CLEAN OIL AND FUEL AND STORE IN APPROVED, CLEAN, COVERED CONTAINERS. USE CLEAN FILL FUNNELS.

## CHECK ENGINE OIL LEVEL (See Fig. 12)

- The engine in your unit has been shipped, from the factory, already filled with SAE 30 summer weight oil.
- With engine level, clean area around oil filler plug and remove plug.
- Engine oil should be to point of overflowing. For approximate capacity see "PRODUCT SPECIFICATIONS" on page 3 of this manual. All oil must meet A.P.I. Service Classification SG.
- For cold weather operation you should change oil for easier starting (See oil viscosity chart in the Customer Responsibilities section of this manual).
- To change engine oil, see the Customer Responsibilities section in this manual.

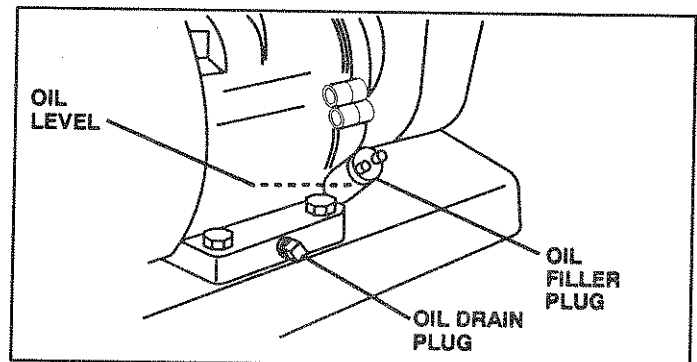

FIG. 12

## ADD GASOLINE

- Fill fuel tank. Use fresh, clean, regular unleaded gasoline. (Use of leaded gasoline will increase carbon and lead oxide deposits and reduce valve life.)

**IMPORTANT:** WHEN OPERATING IN TEMPERATURES BELOW 32°F (0°C), USE FRESH, CLEAN, WINTER GRADE GASOLINE TO HELP INSURE GOOD COLD WEATHER STARTING.

**WARNING:** Experience indicates that alcohol blended fuels (called gasohol or using ethanol or methanol) can attract moisture which leads to separation and formation of acids during storage. Acidic gas can damage the fuel system of an engine while in storage. To avoid engine problems, the fuel system should be emptied before storage of 30 days or longer. Drain the gas tank, start the engine and let it run until the fuel lines and carburetor are empty. Use fresh fuel next season. See Storage Instructions for additional information. Never use engine or carburetor cleaner products in the fuel tank or permanent damage may occur.



**CAUTION:** Fill to within 1/2" (1.3 cm) of top of fuel tank to prevent spills and to allow for fuel expansion. If gasoline is accidentally spilled, move machine away from area of spill. Avoid creating any source of ignition until gasoline vapors have disappeared.

Do not overfill. Wipe off any spilled oil or fuel. Do not store, spill or use gasoline near an open flame.

# OPERATION

## TO START ENGINE (See Fig. 13)



**CAUTION:** Keep the tine control in "OFF" position when starting engine.

- Make sure spark plug wire is properly connected.
- Move shift lever indicator to "N" (neutral) position.
- Place throttle control in "FAST" position.
- Place choke control in "CHOKE" position if the engine is cold. A warm engine may not require choking to start.
- Grasp starter handle with one hand and grasp the tiller with other hand. Pull rope out slowly until engine reaches start of compression cycle (rope will pull slightly harder at this point).
- Pull rope with a rapid, continuous, full arm stroke. Keep a firm grip on starter handle and let rope rewind slowly. Do not let starter handle snap back against starter.
- When engine starts, slowly move choke control on engine halfway between "CHOKE" and "RUN" positions and then to "RUN" position as engine warms up.
- Move throttle control to desired running position.
- Allow engine to warm up for a few minutes before engaging tines.

**NOTE:** If at a high altitude (above 3000 feet/915 m) or in cold temperatures (below 32°F/0°C), the carburetor fuel mixture may need to be adjusted for best engine performance. See engine manual packed with your unit.

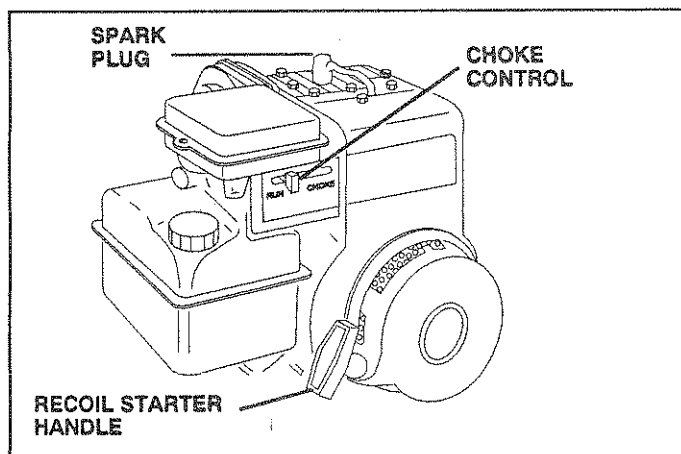

FIG. 13

## TILLING HINTS



**CAUTION:** Until you are accustomed to handling your tiller, start actual field use with throttle in slow position (mid-way between "FAST" and "IDLE").

- Tilling is digging into, turning over, and breaking up packed soil before planting. Loose, unpacked soil helps root growth. Best tilling depth is 4" to 6" (10-15 cm). A tiller will also clear the soil of unwanted vegetation. The decomposition of this vegetable matter enriches the soil. Depending on the climate (rainfall and wind), it may be advisable to till the soil at the end of the growing season to further condition the soil.
- Soil conditions are important for proper tilling. Tines will not readily penetrate dry, hard soil which may contribute to excessive bounce and difficult handling of your tiller. Hard soil should be moistened before tilling; however, extremely wet soil will "ball-up" or clump during tilling. Wait until the soil is less wet in order to achieve the best results. When tilling in the fall, remove vines and long grass to prevent them from wrapping around the tine shaft and slowing your tilling operation.
- For easier handling of your tiller, leave about 8 inches (20 cm) of untilled soil between the first and second tilling passes. The third pass will be between the first and second (See Fig. 14).
- Do not lean on handle. This takes weight off the wheels and reduces traction. To get through a really tough section of sod or hard ground, apply upward pressure on handle or lower the depth stake.

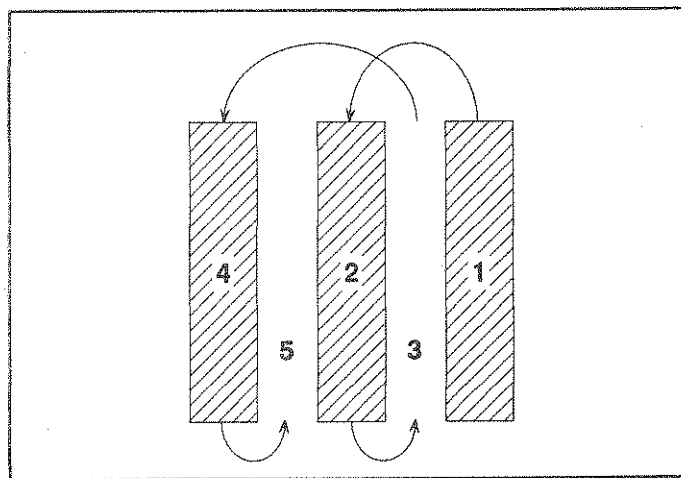

FIG. 14

## TINE SHEAR PINS

The tine assemblies on your tiller are secured to the tine shaft with shear pins (See "TINE REPLACEMENT" in the Service and Adjustments section of this manual).

If the tiller is unusually overloaded or jammed, the shear pins are designed to break before internal damage occurs to the transmission.

- If shear pin(s) break, replace only with those shown in the Repair Parts section of this manual.

# OPERATION

## CULTIVATING

Cultivating is destroying the weeds between rows to prevent them from robbing nourishment and moisture from the plants. At the same time, breaking up the upper layer of soil crust will help retain moisture in the soil. Best digging depth is 1" to 3" (2.5-7.5 cm). Lower the outer side shields to protect small plants from being buried.

- Cultivate up and down the rows at a speed which will allow tines to uproot weeds and leave the ground in rough condition, promoting no further growth of weeds and grass (See Fig. 15).

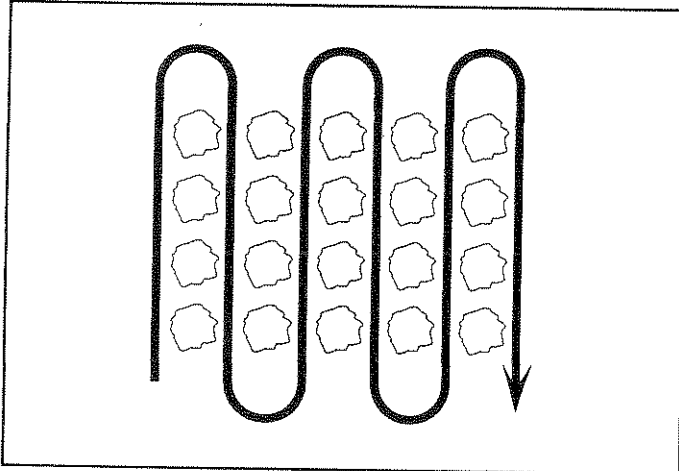

FIG. 15

## ADJUST WHEELS FOR CULTIVATING (See Figs. 16 and 17)

- Place blocks under right hand side of tiller and remove hairpin clip and clevis pin from right hand wheel.
- Move wheel outward approximately 1 inch (2.5 cm) until hole in inner wheel hub lines up with inner hole in axle.

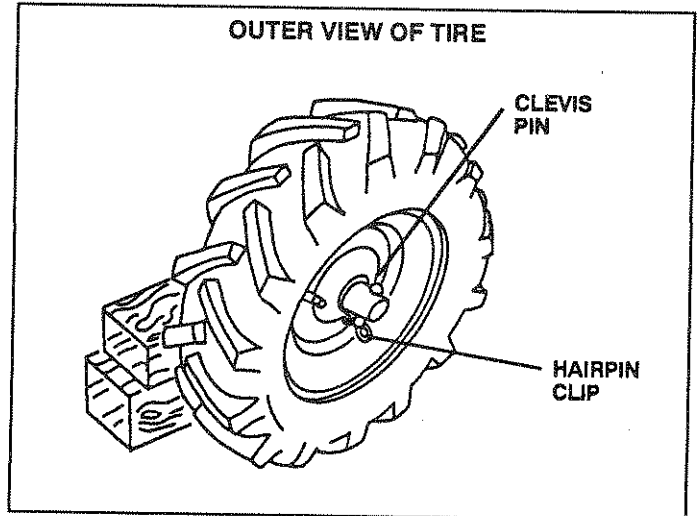

FIG. 16

- Replace clevis pin and hairpin clip on inside of wheel and remove blocks.
- Repeat preceding steps on left hand side.

**NOTE:** In extremely rough conditions and while cultivating, the wheels should be moved outward on the axle for increased stability.

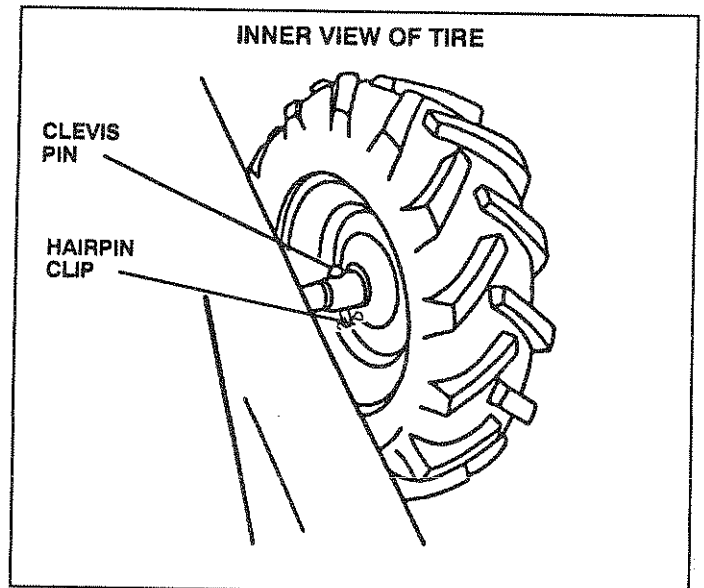

FIG. 17

# CUSTOMER RESPONSIBILITIES

MAINTENANCE SCHEDULE						SERVICE DATES														
	BEFORE EACH USE	FIRST 2 HOURS	EVERY 5 HOURS	EVERY 25 HOURS	EVERY 50 HOURS															
FILL IN DATES AS YOU COMPLETE REGULAR SERVICE																				
Check Engine Oil Level	✓		✓																	
Change Engine Oil		✓		✓ <sub>1,2</sub>																
Oil Pivot Points			✓																	
Inspect Spark Arrester Muffler					✓															
Inspect Air Screen	✓																			
Replace Air Cleaner Cartridge				✓ <sub>2</sub>																
Clean Engine Cylinder Fins				✓																
Replace Spark Plug					✓															

1 - Change more often when operating under a heavy load or in high ambient temperatures.  
 2 - Service more often when operating in dirty or dusty conditions.

## GENERAL RECOMMENDATIONS

The warranty on this unit does not cover items that have been subjected to operator abuse or negligence. To receive full value from the warranty, the operator must maintain unit as instructed in this manual.

Some adjustments will need to be made periodically to properly maintain your unit.

All adjustments in the Service and Adjustments section of this manual should be checked at least once each season.

- Once a year you should replace the spark plug, replace air filter, and check tines and belts for wear. A new spark plug and clean air filter assure proper air-fuel mixture and help your engine run better and last longer.

## BEFORE EACH USE

- Check engine oil level.
- Check tine operation.
- Check for loose fasteners.

## LUBRICATION

Keep unit well lubricated (See "LUBRICATION CHART").

## LUBRICATION CHART

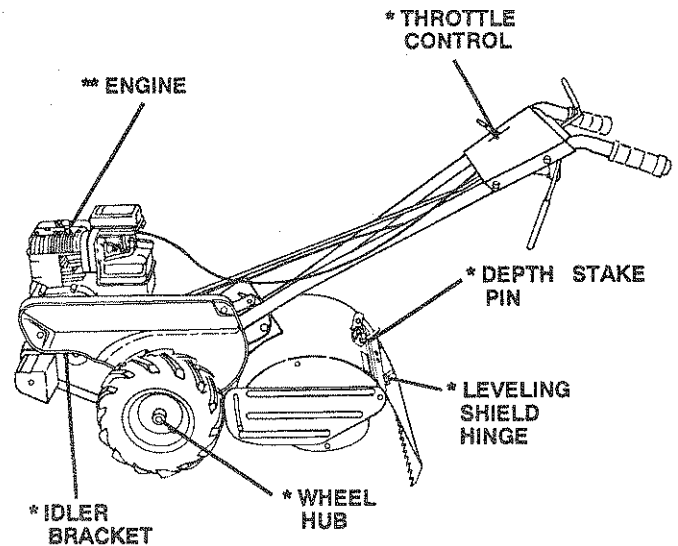

\* SAE 30 OR 10W-30 MOTOR OIL

\*\* REFER TO CUSTOMER RESPONSIBILITIES "ENGINE" SECTION

# CUSTOMER RESPONSIBILITIES



Disconnect spark plug wire before performing any maintenance (except carburetor adjustment) to prevent accidental starting of engine.

Prevent fires! Keep the engine free of grass, leaves, spilled oil, or fuel. Remove fuel from tank before tipping unit for maintenance. Clean muffler area of all grass, dirt, and debris.

Do not touch hot muffler or cylinder fins as contact may cause burns.

## ENGINE

### LUBRICATION

Use only high quality detergent oil rated with API service classification SG. Select the oil's SAE viscosity grade according to your expected temperature.

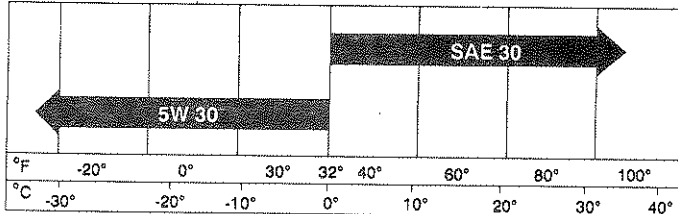

FIG. 18

**NOTE:** Although multi-viscosity oils (5W-30, 10W-30, etc.) improve starting in cold weather, these multi-viscosity oils will result in increased oil consumption when used above 32°F (0°C). Check your engine oil level more frequently to avoid possible engine damage from running low on oil.

Change the oil after the first two hours of operation and every 25 hours thereafter or at least once a year if the tiller is not used for 25 hours in one year.

Check the crankcase oil level before starting the engine and after each five (5) hours of continuous use. Add SAE 30 motor oil or equivalent. Tighten oil filler plug securely each time you check the oil level.

### TO CHANGE ENGINE OIL (See Figs. 18 and 19)

Determine temperature range expected before oil change. All oil must meet API service classification SG.

- Be sure tiller is on level surface.
- Oil will drain more freely when warm.
- Catch oil in a suitable container.
- Remove drain plug.
- Tip tiller forward to drain oil.
- After oil has drained completely, replace oil drain plug and tighten securely.
- Remove oil filler plug. Be careful not to allow dirt to enter the engine.
- Refill engine with oil. See "CHECK ENGINE OIL LEVEL" in the Operation section of this manual.

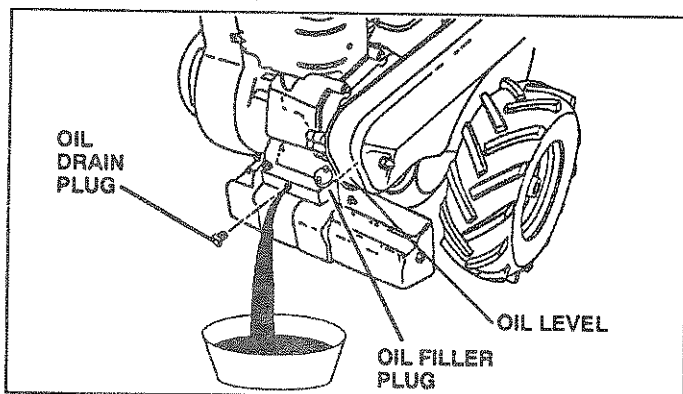

FIG. 19

### AIR CLEANER (See Fig. 20)

Replace air cleaner cartridge every twenty-five hours, more often if engine is used in very dusty conditions.

- Loosen air cleaner screws, one on each side of cover.
- Remove air cleaner cover.
- Carefully remove air cleaner cartridge. Be careful. Do not allow dirt or debris to fall into carburetor.
- Install new air cleaner cartridge. Clean and replace cover. Tighten screws securely.

**NOTE:** Do not attempt to clean or oil the paper cartridge.

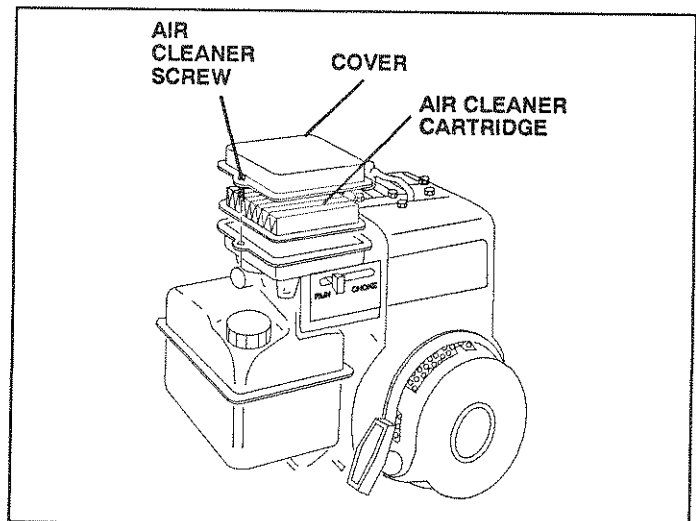

FIG. 20

### COOLING SYSTEM (See Fig. 21)

Your engine is air cooled. For proper engine performance and long life keep your engine clean.

- Clean air screen frequently using a stiff-bristled brush.
- Remove blower housing and clean as necessary.
- Keep cylinder fins free of dirt and chaff.

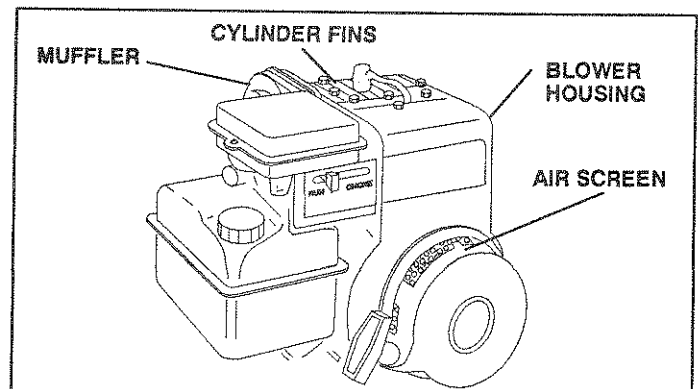

FIG. 21

# CUSTOMER RESPONSIBILITIES

## MUFFLER

Do not operate tiller without muffler. Do not tamper with exhaust system. Damaged mufflers or spark arresters could create a fire hazard. Inspect periodically and replace if necessary. If your engine is equipped with a spark arrester screen assembly, remove every 50 hours for cleaning and inspection. Replace if damaged.

## SPARK PLUG

Replace spark plugs at the beginning of each tilling season or after every 50 hours of use, whichever comes first. Spark plug type and gap setting is shown in "PRODUCT SPECIFICATIONS" on page 3 of this manual.

## TRANSMISSION

Your transmission is sealed and will only require lubrication if serviced.

## CLEANING

- Clean engine, wheels, finish, etc. of all foreign matter.
- Keep finished surfaces and wheels free of all gasoline oil, etc.
- Protect painted surfaces with automotive type wax.

We do not recommend using a garden hose to clean your unit unless the muffler, air filter and carburetor are covered to keep water out. Water in engine can result in a shortened engine life.

# SERVICE AND ADJUSTMENTS



**CAUTION:** Disconnect spark plug wires from spark plug and place wire where it cannot come into contact with plug.

## TILLER

### TO ADJUST HANDLE HEIGHT (See Fig. 22)

Select handle height best suited for your tilling conditions. Handle height will be different when tiller digs into soil.

- First loosen handle lock lever.
- Handle can be positioned at different settings between "HIGH" and "LOW" positions.
- Retighten handle lock lever securely after adjusting.

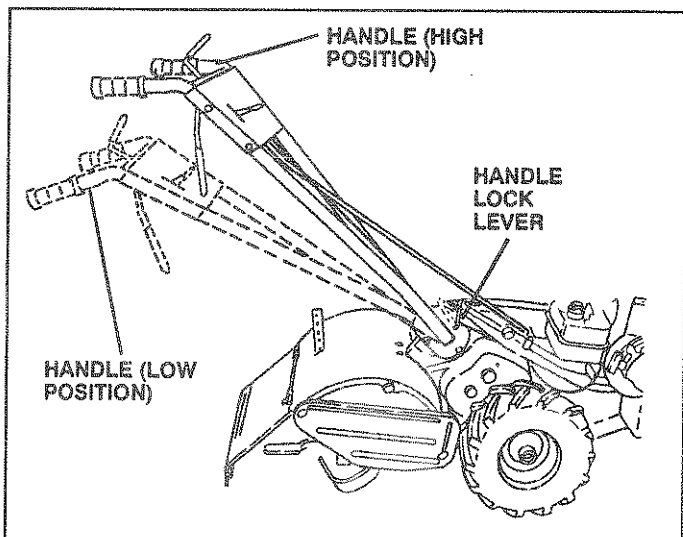

FIG. 22

## TIRE CARE



**CAUTION:** When mounting tires, unless beads are seated, overinflation can cause an explosion.

- Maintain 20 PSI (1.4 kg/cm<sup>2</sup>) of tire pressure. If tire pressures are not equal, tiller will pull to one side.
- Keep tires free of gasoline or oil which can damage rubber.

### TO REMOVE WHEEL (See Fig. 23)

- Place blocks under transmission to keep tiller from tipping.
- Remove hairpin clip and clevis pin from wheel.
- Remove wheel and tire.
- Repair tire and reassemble.

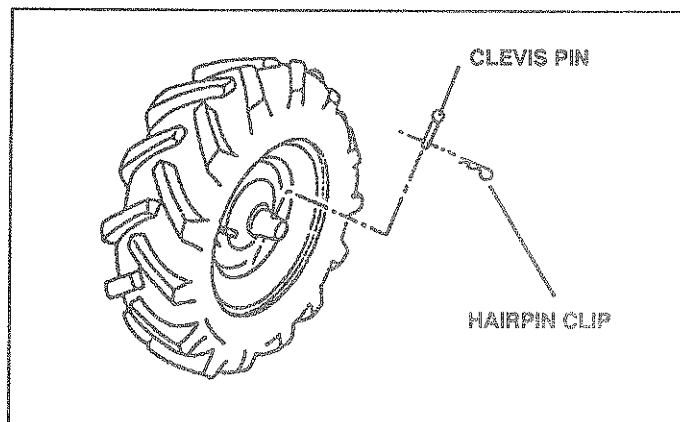

FIG. 23

# SERVICE AND ADJUSTMENTS

## TO REMOVE BELT GUARD (See Fig. 24)

**NOTE:** For ease of removal, remove hairpin clip and clevis pin from left wheel. Pull wheel out from tiller about 1 inch (2.5 cm).

- Remove two (2) cap nuts and washers from side of belt guard.
- Remove hex nut and washer from bottom of belt guard (located behind wheel).
- Pull belt guard out and away from unit.
- Replace belt guard by reversing above procedure.

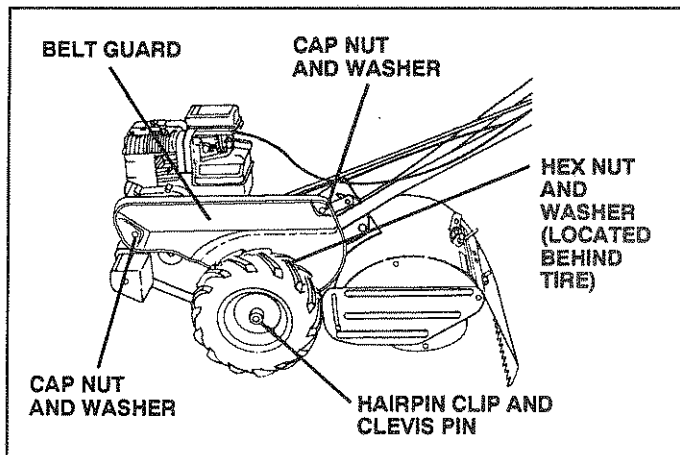

FIG. 24

## TO REPLACE GROUND DRIVE BELT (See Figs. 24 and 25)

- Move left wheel and remove belt guard as described in "TO REMOVE BELT GUARD".
- Loosen belt guides "A" and "B" and also nuts "C" and "D".
- Remove old belt by slipping from engine pulley first.
- Place new belt in groove of transmission pulley and into engine pulley. **BELT MUST BE IN GROOVE ON TOP OF IDLER PULLEY.** NOTE POSITION OF BELT TO GUIDES.
- Tighten belt guides "A" and "B" and nuts "C" and "D".
- Check belt adjustment as described below.
- Replace belt guard.
- Reposition wheel and replace clevis pin and hairpin clip.

## GROUND DRIVE BELT ADJUSTMENT (See Fig. 25)

For proper belt tension, the extension spring should have about 5/8 inch (16 mm) stretch when drive control bar is in "ENGAGED" position. This tension can be attained as follows:

- Loosen cable clip screw securing the drive control cable.
- Slide cable forward for less tension and rearward for more tension until about 5/8 inch (16 mm) stretch is obtained while the drive control bar is engaged.
- Tighten cable clip screw securely.

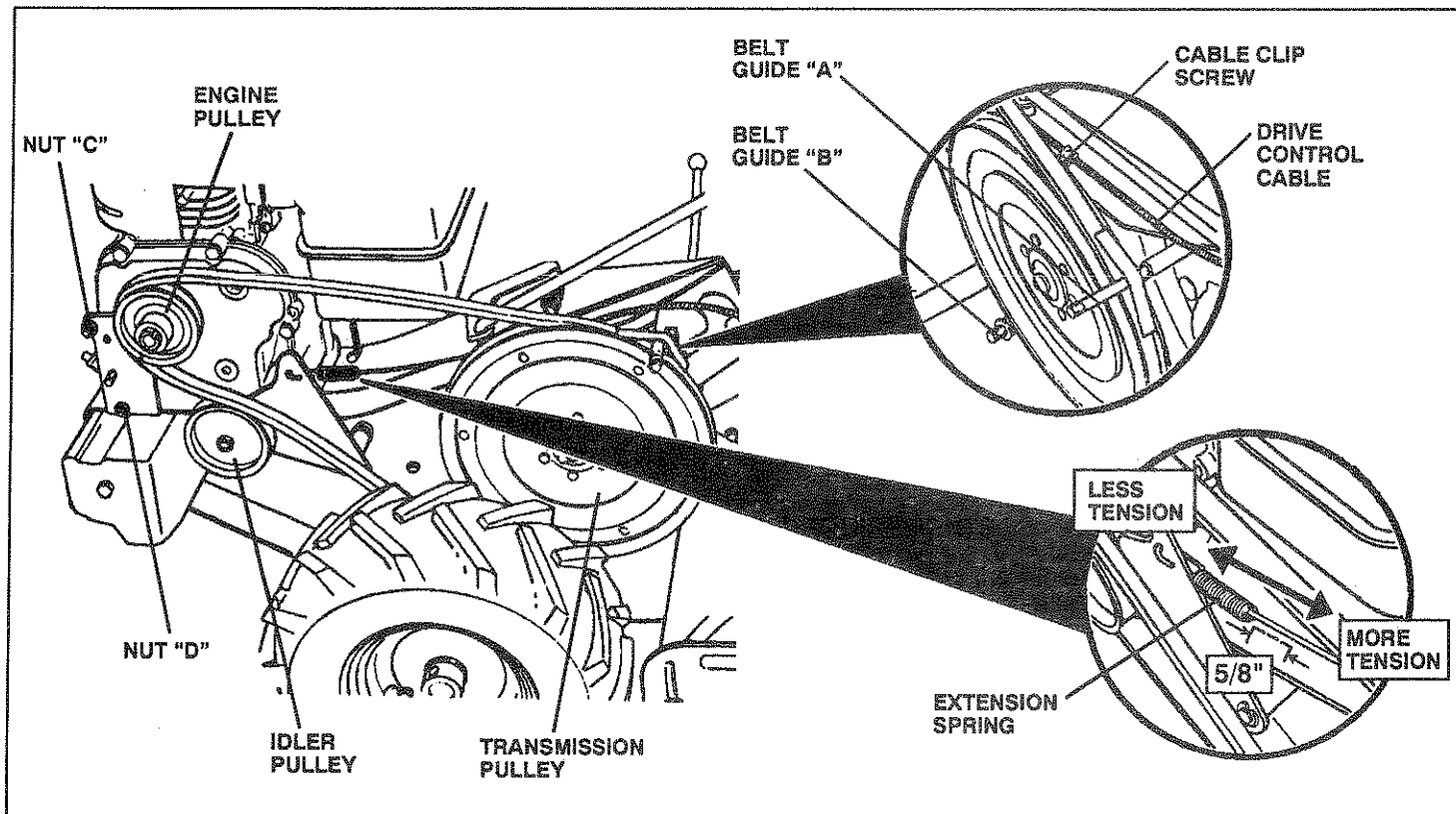

FIG. 25



# SERVICE AND ADJUSTMENTS

## TINE REPLACEMENT (See Figs. 26, 27 and 28)



**CAUTION:** Tines are sharp. Wear gloves or other protection when handling tines.

A badly worn tine causes your tiller to work harder and dig more shallow. Most important, worn tines cannot chop and shred organic matter as effectively nor bury it as deeply as good tines. A tine this worn needs to be replaced.

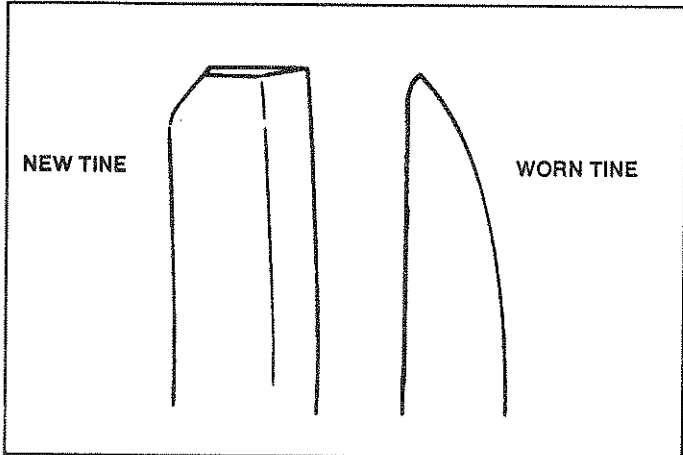

FIG. 26

- To maintain the superb tilling performance of this machine the tines should be checked for sharpness, wear, and bending, particularly the tines which are next to the transmission. If the gap between the tines exceeds 3-1/2 inches (9 cm), they should be replaced or straightened as necessary.
- New tines should be assembled as shown in Fig. 28. Sharpened tine edges will rotate rearward from above.

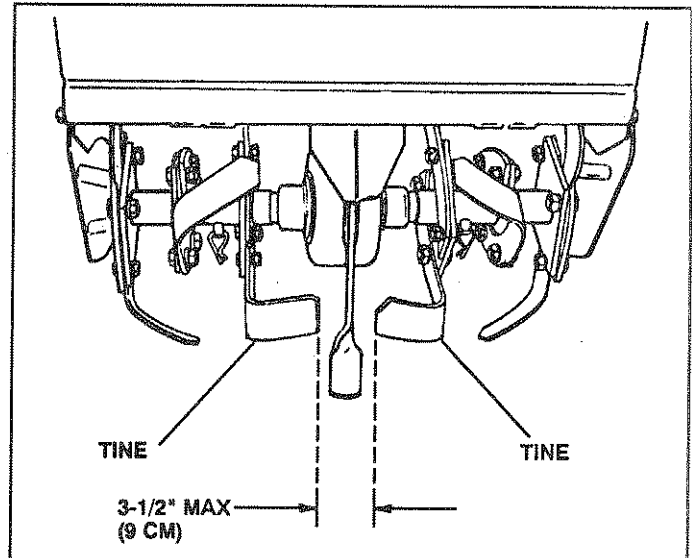

FIG. 27

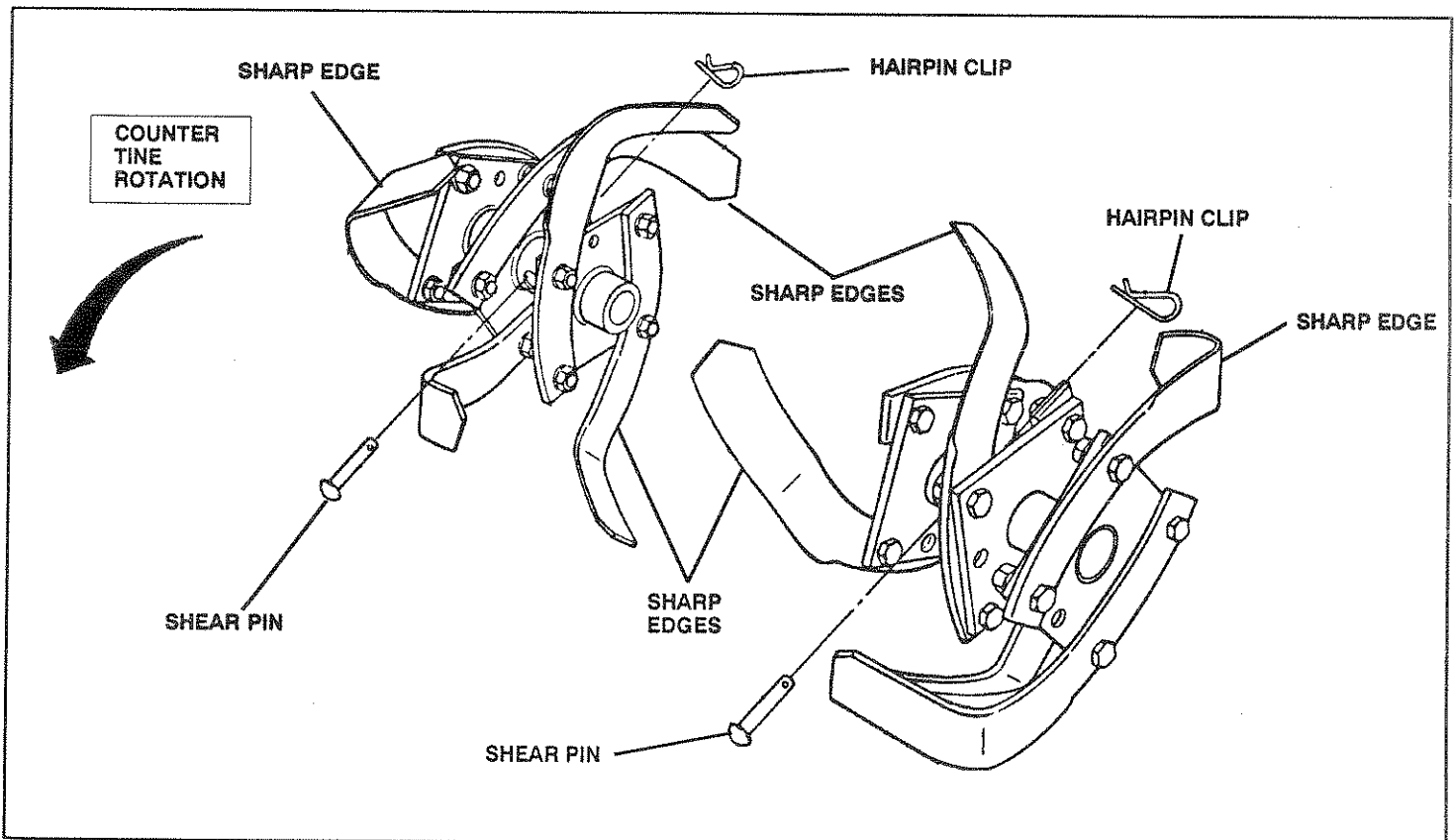

FIG. 28

# SERVICE AND ADJUSTMENTS

## ENGINE

### TO ADJUST THROTTLE CONTROL CABLE (See Fig. 29)

- Loosen cable clamp screw to allow cable to move.
- Move throttle control lever on upper handle to "FAST" position.
- Pull throttle cable out until engine bellcrank is back as far as it will go.
- Hold cable in this position and tighten clamp screw securely.

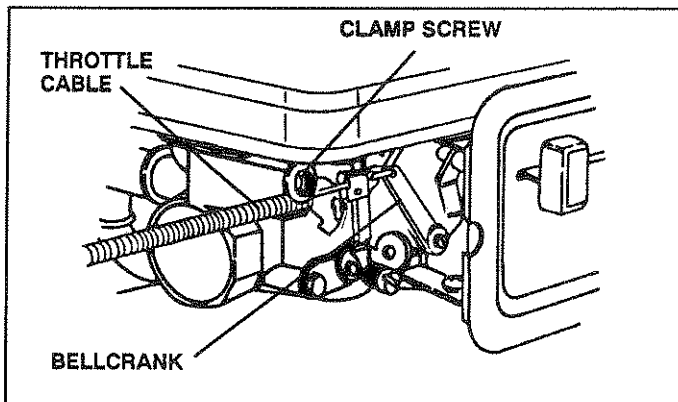

FIG. 29

### TO ADJUST CARBURETOR

The carburetor has been preset at the factory and adjustment should not be necessary. However, minor adjustments may be required to compensate for differences in fuel, temperature, altitude or load. If the carburetor does need adjustment, see the engine manual packed with your unit.

**IMPORTANT:** NEVER TAMPER WITH THE ENGINE GOVERNOR, WHICH IS FACTORY SET FOR PROPER ENGINE SPEED. OVERSPEEDING THE ENGINE ABOVE THE FACTORY HIGH SPEED SETTING CAN BE DANGEROUS. IF YOU THINK THE ENGINE-GOVERNED HIGH SPEED NEEDS ADJUSTING, CONTACT YOUR NEAREST AUTHORIZED SERVICE CENTER, WHICH HAS THE PROPER EQUIPMENT TO MAKE ANY NECESSARY ADJUSTMENTS.

# STORAGE

Immediately prepare your tiller for storage at the end of the season or if the unit will not be used for 30 days or more.



**CAUTION:** Never store the tiller with gasoline in the tank inside a building where fumes may reach an open flame or spark. Allow the engine to cool before storing in any enclosure.

## TILLER

- Clean entire tiller (See "CLEANING" in the Customer Responsibilities section of this manual).
- Inspect and replace belts, if necessary (See belt replacement instructions in the Service and Adjustments section of this manual).
- Lubricate as shown in the Customer Responsibilities section of this manual.
- Be sure that all nuts, bolts and screws are securely fastened. Inspect moving parts for damage, breakage and wear. Replace if necessary.
- Touch up all rusted or chipped paint surfaces; sand lightly before painting.

## ENGINE

### FUEL SYSTEM

**IMPORTANT:** IT IS IMPORTANT TO PREVENT GUM DEPOSITS FROM FORMING IN ESSENTIAL FUEL SYSTEM PARTS SUCH AS THE CARBURETOR, FUEL FILTER, FUEL HOSE, OR TANK DURING STORAGE. ALSO, EXPERIENCE INDICATES THAT ALCOHOL BLENDED FUELS (CALLED GASOHOL OR USING ETHANOL OR METHANOL) CAN ATTRACT MOISTURE WHICH LEADS TO SEPARATION AND FORMATION OF ACIDS DURING STORAGE. ACIDIC GAS CAN DAMAGE THE FUEL SYSTEM OF AN ENGINE WHILE IN STORAGE.

- Drain the fuel tank.
- Start the engine and let it run until the fuel lines and carburetor are empty.
- Never use engine or carburetor cleaner products in the fuel tank or permanent damage may occur.
- Use fresh fuel next season.

**NOTE:** Fuel stabilizer is an acceptable alternative in minimizing the formation of fuel gum deposits during storage. Add stabilizer to gasoline in fuel tank or storage container. Always follow the mix ratio found on stabilizer container. Run engine at least 10 minutes after adding stabilizer to allow the stabilizer to reach the carburetor. Do not drain the gas tank and carburetor if using fuel stabilizer.

## ENGINE OIL

Drain oil (with engine warm) and replace with clean oil. (See "ENGINE" in the Customer Responsibilities section of this manual).

## CYLINDERS

- Remove spark plug.
- Pour 1 ounce (29 ml) of oil through spark plug hole into cylinder.
- Pull starter handle slowly several times to distribute oil.
- Replace with new spark plug.

## OTHER

- Do not store gasoline from one season to another.
- Replace your gasoline can if your can starts to rust. Rust and/or dirt in your gasoline will cause problems.
- If possible, store your unit indoors and cover it to give protection from dust and dirt.
- Cover your unit with a suitable protective cover that does not retain moisture. Do not use plastic. Plastic cannot breathe which allows condensation to form and will cause your unit to rust.

**IMPORTANT:** NEVER COVER TILLER WHILE ENGINE AND EXHAUST AREAS ARE STILL WARM.

# TROUBLESHOOTING POINTS

PROBLEM	CAUSE	CORRECTION
<b>Will not start</b>	<ol style="list-style-type: none"> <li>1. Out of fuel.</li> <li>2. Engine not "CHOKED" properly.</li> <li>3. Engine flooded.</li> <li>4. Dirty air cleaner.</li> <li>5. Water in fuel.</li> <li>6. Clogged fuel tank.</li> <li>7. Loose spark plug wire.</li> <li>8. Bad spark plug or improper gap.</li> <li>9. Carburetor out of adjustment.</li> </ol>	<ol style="list-style-type: none"> <li>1. Fill fuel tank.</li> <li>2. See "TO START ENGINE" in Operation section.</li> <li>3. Wait several minutes before attempting to start.</li> <li>4. Replace air cleaner cartridge.</li> <li>5. Drain fuel tank and carburetor, and refill tank with fresh gasoline.</li> <li>6. Remove fuel tank and clean.</li> <li>7. Make sure spark plug wire is seated properly on plug.</li> <li>8. Replace spark plug or adjust gap.</li> <li>9. Make necessary adjustments.</li> </ol>
<b>Hard to start</b>	<ol style="list-style-type: none"> <li>1. Throttle control not set properly.</li> <li>2. Dirty air cleaner.</li> <li>3. Bad spark plug or improper gap.</li> <li>4. Stale or dirty fuel.</li> <li>5. Loose spark plug wire.</li> <li>6. Carburetor out of adjustment.</li> </ol>	<ol style="list-style-type: none"> <li>1. Place throttle control in "FAST" position.</li> <li>2. Replace air cleaner cartridge.</li> <li>3. Replace spark plug or adjust gap.</li> <li>4. Drain fuel tank and refill with fresh gasoline.</li> <li>5. Make sure spark plug wire is seated properly on plug.</li> <li>6. Make necessary adjustments.</li> </ol>
<b>Loss of power</b>	<ol style="list-style-type: none"> <li>1. Engine is overloaded.</li> <li>2. Dirty air cleaner.</li> <li>3. Low oil level/dirty oil.</li> <li>4. Faulty spark plug.</li> <li>5. Oil in fuel.</li> <li>6. Stale or dirty fuel.</li> <li>7. Water in fuel.</li> <li>8. Clogged fuel tank.</li> <li>9. Spark plug wire loose.</li> <li>10. Dirty engine air screen.</li> <li>11. Dirty/clogged muffler.</li> <li>12. Carburetor out of adjustment.</li> <li>13. Poor compression.</li> </ol>	<ol style="list-style-type: none"> <li>1. Set depth stake for shallower tilling.</li> <li>2. Replace air cleaner cartridge.</li> <li>3. Check oil level/change oil.</li> <li>4. Clean and regap or change spark plug.</li> <li>5. Drain and clean fuel tank and refill, and clean carburetor.</li> <li>6. Drain fuel tank and refill with fresh gasoline.</li> <li>7. Drain fuel tank and carburetor, and refill tank with fresh gasoline.</li> <li>8. Remove fuel tank and clean.</li> <li>9. Connect and tighten spark plug wire.</li> <li>10. Clean engine air screen.</li> <li>11. Clean/replace muffler.</li> <li>12. Make necessary adjustments.</li> <li>13. Contact an authorized service center.</li> </ol>
<b>Engine overheats</b>	<ol style="list-style-type: none"> <li>1. Low oil level/dirty oil.</li> <li>2. Dirty engine air screen.</li> <li>3. Dirty engine.</li> <li>4. Partially plugged muffler.</li> <li>5. Improper carburetor adjustment.</li> </ol>	<ol style="list-style-type: none"> <li>1. Check oil level/change oil.</li> <li>2. Clean engine air screen.</li> <li>3. Clean cylinder fins, air screen, and muffler area.</li> <li>4. Remove and clean muffler.</li> <li>5. Adjust carburetor to richer position.</li> </ol>
<b>Excessive bounce/ difficult handling</b>	<ol style="list-style-type: none"> <li>1. Ground too dry and hard.</li> </ol>	<ol style="list-style-type: none"> <li>1. Moisten ground or wait for more favorable soil conditions.</li> </ol>
<b>Soil balls up or clumps</b>	<ol style="list-style-type: none"> <li>1. Ground too wet.</li> </ol>	<ol style="list-style-type: none"> <li>1. Wait for more favorable soil conditions.</li> </ol>
<b>Engine runs but tiller won't move</b>	<ol style="list-style-type: none"> <li>1. Drive control bar is not engaged.</li> <li>2. V-belt not correctly adjusted.</li> <li>3. V-belt is off pulley(s).</li> </ol>	<ol style="list-style-type: none"> <li>1. Engage drive control.</li> <li>2. Inspect/adjust V-belt.</li> <li>3. Inspect V-belt.</li> </ol>
<b>Engine runs but labors when tilling</b>	<ol style="list-style-type: none"> <li>1. Tilling too deep.</li> <li>2. Throttle control not properly adjusted.</li> <li>3. Carburetor out of adjustment.</li> </ol>	<ol style="list-style-type: none"> <li>1. Set depth stake for shallower tilling.</li> <li>2. Check throttle control setting.</li> <li>3. Make necessary adjustments.</li> </ol>
<b>Tines will not rotate</b>	<ol style="list-style-type: none"> <li>1. Shear pin(s) broken.</li> </ol>	<ol style="list-style-type: none"> <li>1. Replace shear pin(s).</li> </ol>

# REPAIR PARTS

## 5 HP 17" TILLER - - MODEL NUMBER WER500A

### HANDLE ASSEMBLY

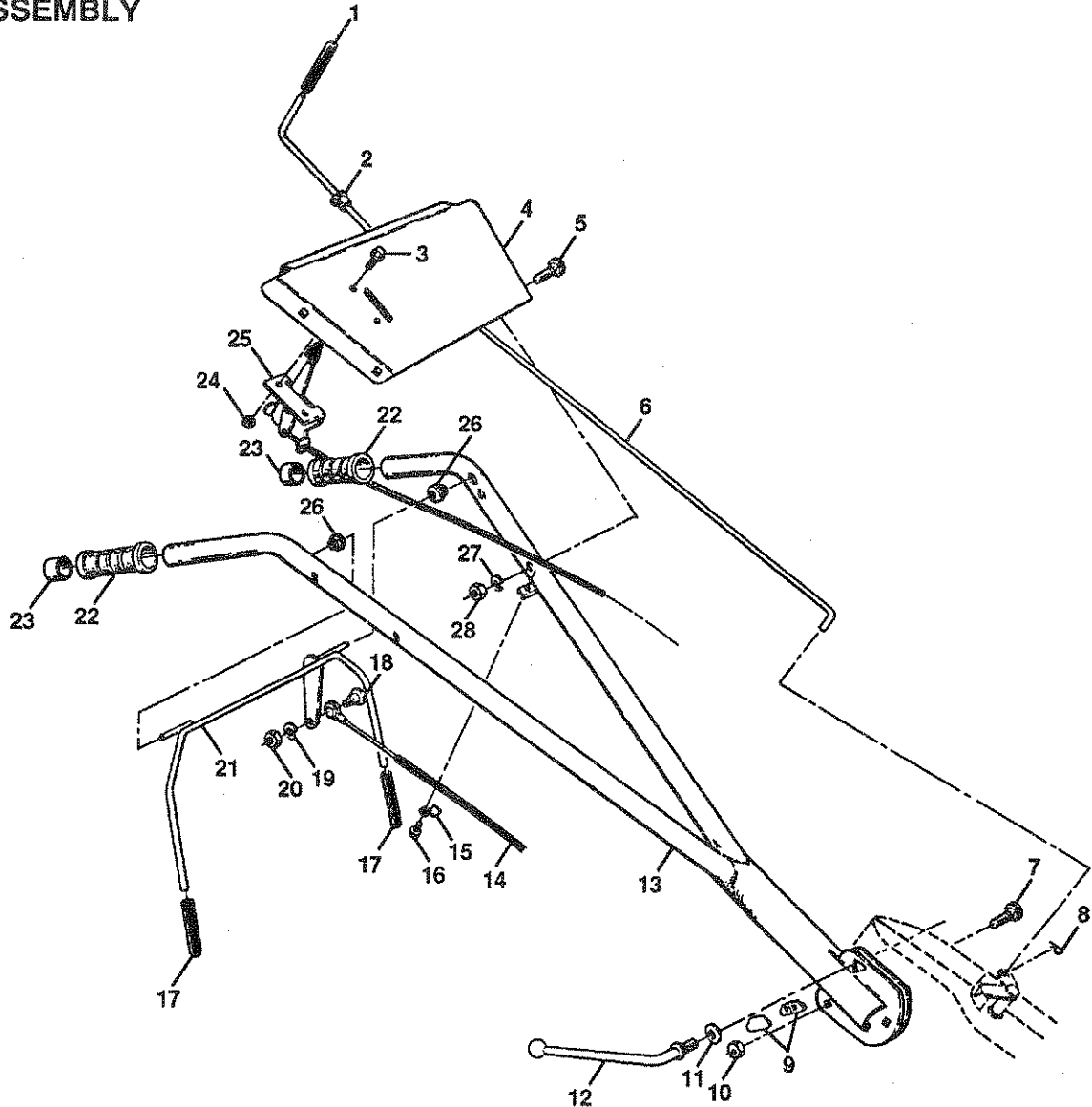

KEY NO.	PART NO.	DESCRIPTION	KEY NO.	PART NO.	DESCRIPTION
1	8389J	Grip, Handle	20	73220400	* Nut, Hex 1/4-20
2	121248X	Bushing, Snap	21	108276X	Bar, Control
3	71091008	* Screw, Machine, Pan Hd. CR. #10-24 x 1/2	22	108279X	Grip, Handle
4	126949X419	Bracket, Handle	23	108544X	Cap, Sleeve
5	72110514	* Bolt, Carriage 5/16-18 x 1-3/4	24	73731000	* Nut, Keps #10-24 UNC
6	108281X	Rod, Shift	25	127012X	Control, Throttle
7	72110608	* Bolt, Carriage 3/8-16 x 1 Gr. 5	26	5420J	Grommet, Handle
8	4497H	Clip, Hairpin	27	10040500	* Washer, Lock 5/16
9	109229X	Lock, Handle	28	1685H	Nut, Lock 5/16-18
10	5394H	Nut 3/8-16	--	120431X	Decal, Hand Placement (Handle)
11	19131611	* Washer 13/32 x 1 x 11 Ga.	--	110655X	Decal, Tine Control (Handle Bracket)
12	109228X	Lever, Lock, Handle	--	132385	Decal (Handle Bracket)
13	121566X	Handle	--	132383	Manual, Owner's
14	102162X	Cable, Clutch			
15	9484R	Clip			
16	86777	Screw, Hex Wsh. Hd. #10-24 x 1/2			
17	102604X	Grip, Bar Control			
18	81328	Bolt, Shoulder			
19	10040400	* Washer, Lock 1/4			

\* STANDARD HARDWARE - - PURCHASE LOCALLY

NOTE: All component dimensions given in U.S. inches.  
1 inch = 25.4 mm

# REPAIR PARTS

## 5 HP 17" TILLER - - MODEL NUMBER WER500A

### MAINFRAME, LEFT SIDE

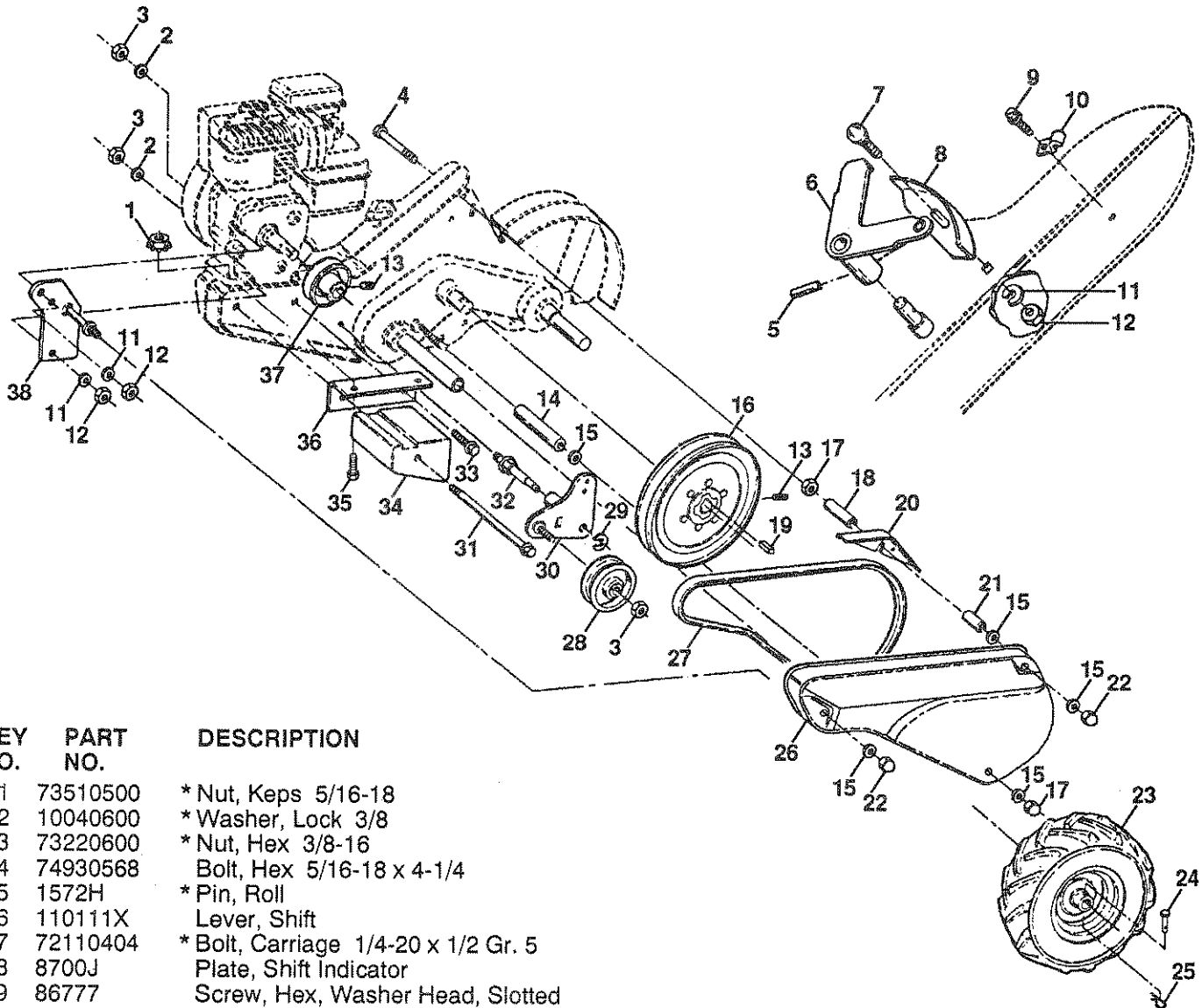

KEY NO.	PART NO.	DESCRIPTION
1	73510500	* Nut, Keps 5/16-18
2	10040600	* Washer, Lock 3/8
3	73220600	* Nut, Hex 3/8-16
4	74930568	Bolt, Hex 5/16-18 x 4-1/4
5	1572H	* Pin, Roll
6	110111X	Lever, Shift
7	72110404	* Bolt, Carriage 1/4-20 x 1/2 Gr. 5
8	8700J	Plate, Shift Indicator
9	86777	Screw, Hex, Washer Head, Slotted #10-24 x 1/2
10	9484R	Clip
11	10040400	* Washer, Lock 1/4
12	73220400	* Nut, Hex 1/4-20
13	23230506	* Screw, Set, Hex 5/16-18 x 3/8
14	120938X	Spacer, Split 0.327 x 0.42 x 2.68
15	19111116	* Washer 11/32 x 11/16 x 16 Ga.
16	100473M	Sheave, Transmission
17	73220500	* Nut, Hex 5/16-18
18	110651X	Spacer, Split 0.327 x 0.42 x 1.75
19	2649M	Key, Square 3/16 x 1-1/8
20	110653X	Guard, Pinch Point
21	131691	Spacer, Split 0.327 x 0.42 x 1.627
22	104214X	Nut, Cap 5/16-18
23	102190X	Tire
	124258X	Rim
	795R	Tire Valve
24	126875X	Rivet, Drilled
25	4497H	* Clip, Hairpin
26	131159X419	Guard, Belt
27	132672	Belt, V

KEY NO.	PART NO.	DESCRIPTION
28	104679X	Pulley, Idler
29	12000032	Ring, Klip
30	105611X	Bracket, Idler
31	102384X	Bolt, Hex 5/16-16 x 12
32	102141X	Shaft, Idler Arm
33	74760616	* Bolt, Hex 3/8-16 x 1
34	102383X	Counterweight, L. H.
35	74760524	Bolt, Hex 5/16-18 x 1-1/2
36	102331X	Bracket, Reinforcement, L. H.
37	130816	Sheave, Engine
38	131558	Bracket, Guard Belt
--	102180X	Decal, Shift Indicator
--	132386	Decal, Logo (Belt Guard)

\* STANDARD HARDWARE - - PURCHASE LOCALLY

**NOTE:** All component dimensions given in U.S. inches.  
1 inch = 25.4 mm

# REPAIR PARTS

5 HP 17" TILLER - - MODEL NUMBER WER500A

MAINFRAME, RIGHT SIDE

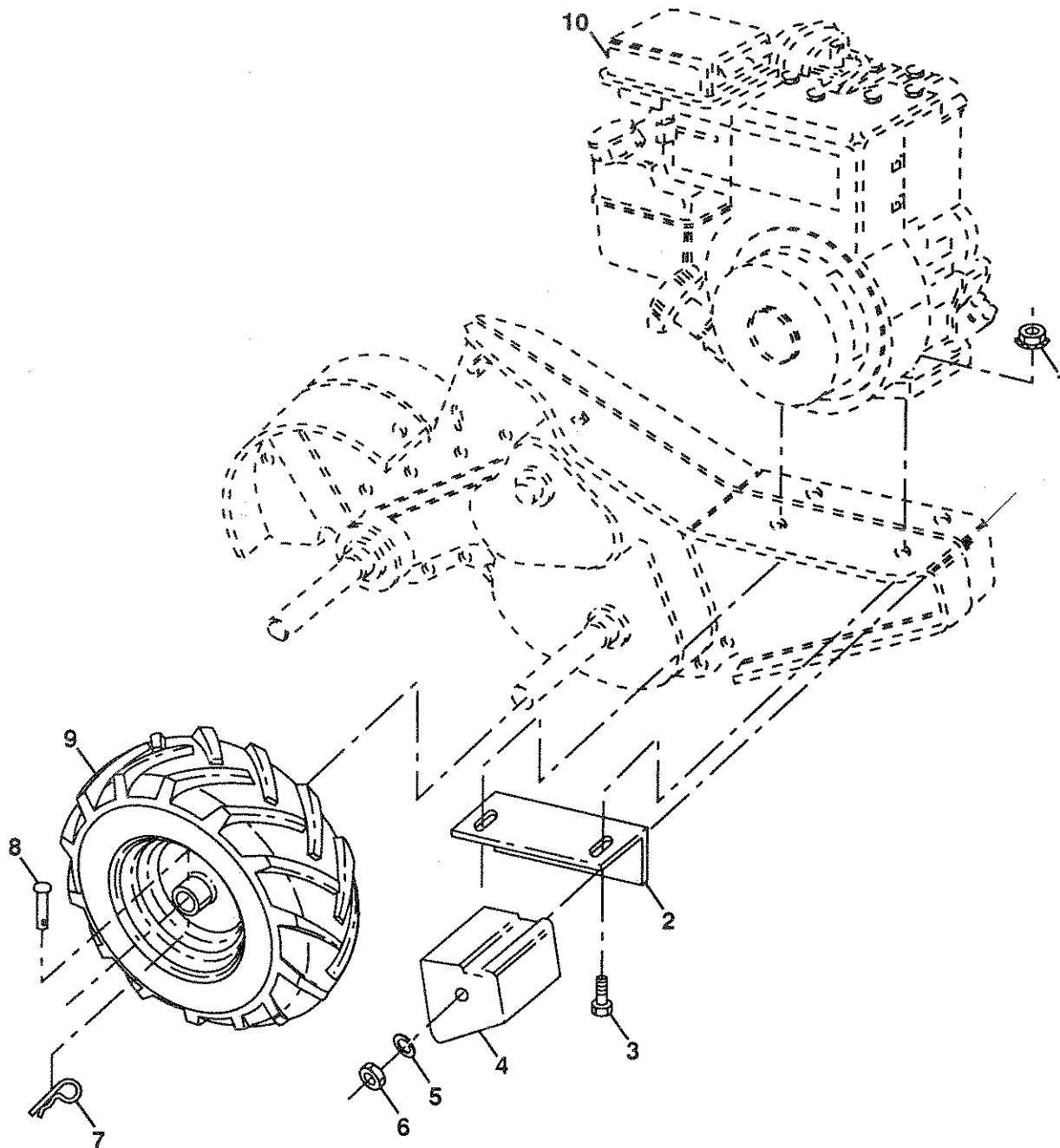

KEY NO.	PART NO.	DESCRIPTION
1	73510500	* Nut, Keps 5/16-18
2	102332X	Bracket, Reinforcment
3	74760524	Bolt, Hex 5/16-18 x 1-1/2
4	102173X	Counter Weight, R.H.
5	10040600	* Washer, Lock 3/8
6	73220600	* Nut, Hex 3/8-16
7	4497H	* Clip, Hairpin
8	126875X	Rivet, Drilled

KEY NO.	PART NO.	DESCRIPTION
9	102190X	Tire
	124258X	Rim
	795R	Tire Valve
10	-----	Engine, Briggs & Stratton Model No. 130202
--	121543X	Decal, Engine
--	110593X	Decal, Caution (Top of Engine)

\* STANDARD HARDWARE - - PURCHASE LOCALLY  
**NOTE:** All component dimensions given in U.S.inches.  
 1 inch = 25.4 mm

# REPAIR PARTS

## 5 HP 17" TILLER - - MODEL NUMBER WER500A

### TRANSMISSION

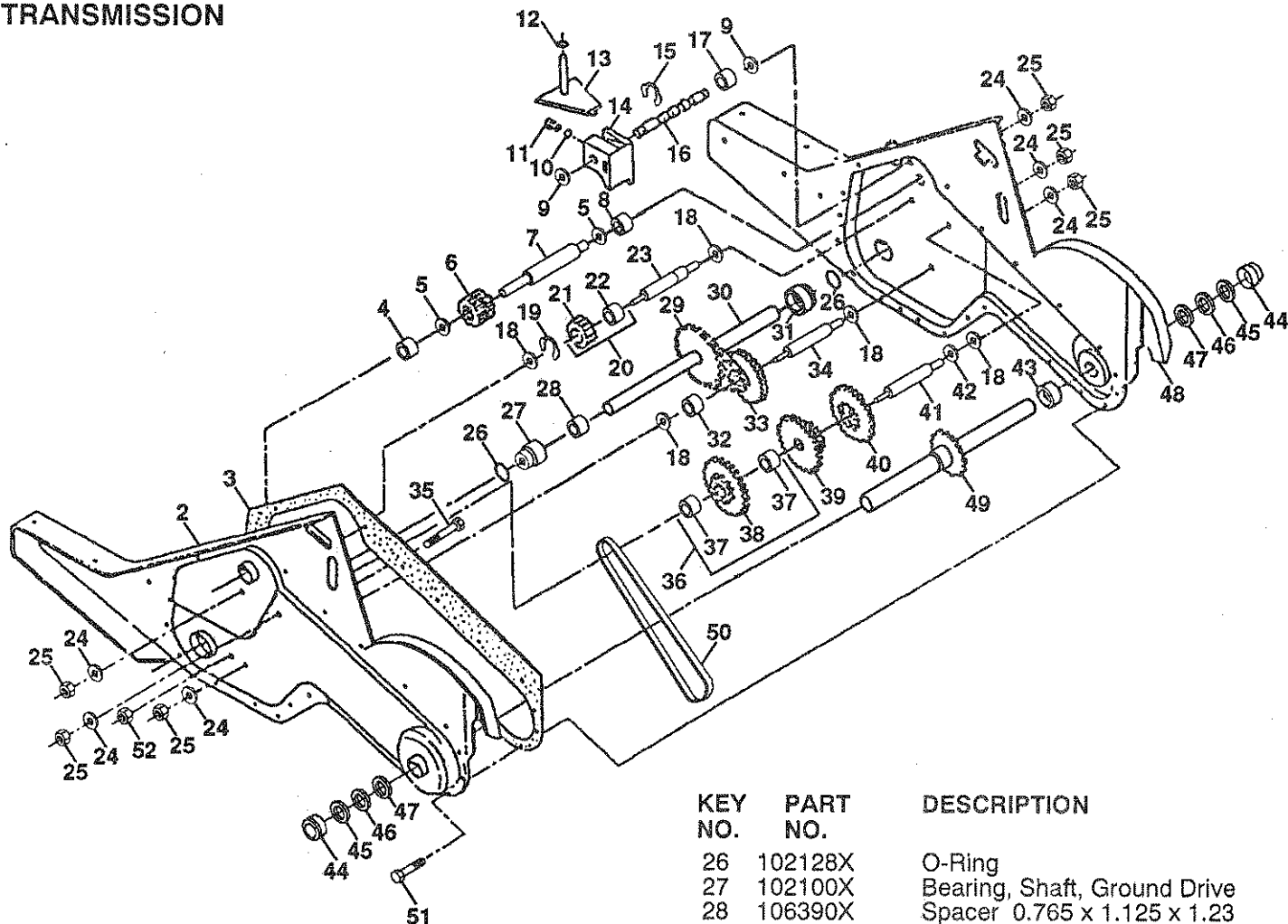

KEY NO.	PART NO.	DESCRIPTION
1	132718	Transmission Assembly (Includes Key Nos. 2-52)
2	121147X	Gearcase, L.H. w/Bearing (Includes Key No. 4)
3	106211X	Gasket, Gearcase
4	5020J	Bearing, Needle
5	1370H	Washer, Thrust 5/8 x 1.10 x 1/32
6	102113X	Pinion, Input
7	102110X	Shaft, Input
8	4895H	Bearing, Needle
9	102136X	Washer, Seal
10	7392M	Ball, Steel
11	100371K	Spring, Shift, Fork
12	106160X	O-Ring
13	102107X	Arm, Shift
14	8353J	Fork, Shift
15	12000039	Ring, Klip
16	102109X	Shaft, Shift
17	104159X	Spacer, Split
18	4358J	Washer
19	12000040	Ring, Klip
20	102114X	Gear, Assembly, Reverse Idler (Includes Key Nos. 21 and 22)
21	102115X	Gear, Reverse Idler
22	6803J	Bearing, Needle
23	102111X	Shaft, Reverse Idler
24	10040700	* Washer, Lock 7/16
25	73610700	* Nut, Hex 7/16-20

KEY NO.	PART NO.	DESCRIPTION
26	102128X	O-Ring
27	102100X	Bearing, Shaft, Ground Drive
28	106390X	Spacer 0.765 x 1.125 x 1.23
29	102134X	Chain #35-50 Pitch
30	109204X	Ground Shaft Assembly
31	102106X	Bearing, Shaft, Ground Drive
32	106388X	Spacer 0.70 x 1.00 x 1.150
33	102121X	Sprocket and Gear Assembly
34	102112X	Shaft, Reduction (2nd)
35	102101X	Screw, Whiz, Lock 5/16-18 x 3-1/2
36	106141X	Sprocket Assembly w/Bearing (Includes Key Nos. 37 and 38)
37	4422J	Bearing, Needle
38	106142X	Sprocket, Tine
39	105345X	Gear, Cluster, Red 1st & 2nd
40	105346X	Gear, Reverse
41	8358J	Shaft, Reduction (1st)
42	4220R	Washer, Thrust
43	106146X	Spacer 1.01 x 1.75 x 0.760
44	9672R	Cup, Formed
45	102144X	Ring, Spiral
46	9676R	Seal, Ring, Rubber
47	9674R	Seal, Oil
48	121745X	Gearcase, R.H. w/Bearing (Includes Key No. 8)
49	132688	Shaft, Tine
50	106147X	Chain, Roller #50-50 Pitch
51	17580408	Screw 1/4-20 x 1/2
52	73220500	* Nut, Hex 5/16-18
--	6066J	Grease, Plastilube #1

\* STANDARD HARDWARE - - PURCHASE LOCALLY.

NOTE: All component dimensions given in U.S. inches.

1 inch = 25.4 mm



# REPAIR PARTS

## 5 HP 17" TILLER - - MODEL NUMBER WER500A

### TINE SHIELD

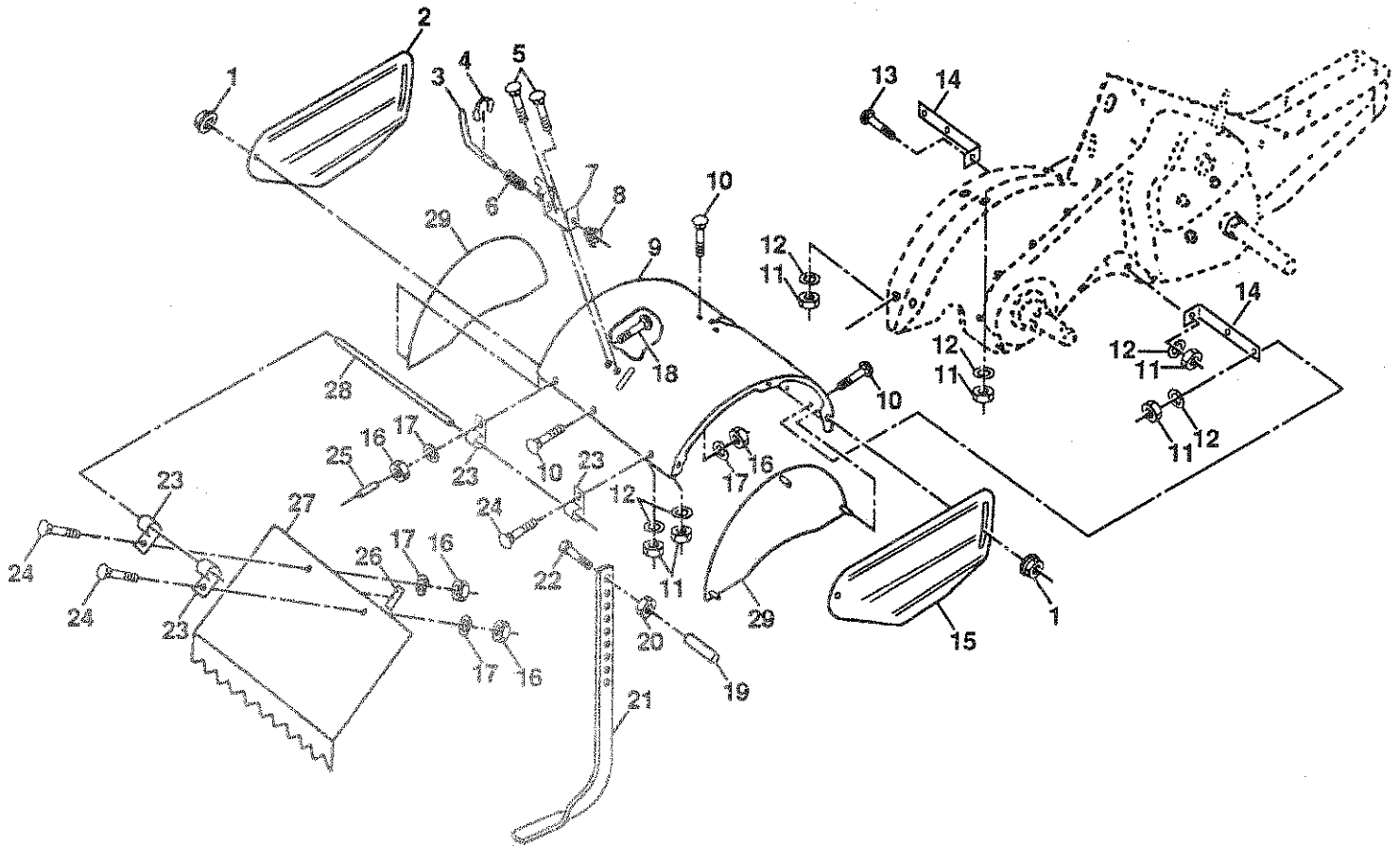

KEY NO.	PART NO.	DESCRIPTION	KEY NO.	PART NO.	DESCRIPTION
1	98000129	Nut, Flange 5/16-18	19	102701X	Grip
2	104086X	Shield, Side, Outer L. H.	20	73220600	* Nut, Hex 3/8-16
3	8393J	Pin, Stake, Depth	21	102156X	Stake, Depth
4	12000036	Ring, Klip	22	74930632	Bolt, Hex 3/8-16 x 2
5	72110508	Bolt, Carriage 5/16-18 x 1	23	4440J	Hinge
6	8394J	Spring	24	72140404	* Bolt, Carriage 1/4-20 x 1/2 Gr. 5
7	8392J	Bracket, Latch	25	6712J	Cap, Vinyl
8	109230X	Spring, Depth Stake	26	109227X	Pad, Idler
9	102326X419	Shield, Tine	27	102695X419	Shield, Leveling
10	72140506	* Bolt, Carriage 5/16-18 x 3/4 Gr 5	28	120588X	Pin, Hinge
11	73220500	* Nut, Hex 5/16-18	29	104085X419	Shield, Side
12	10040500	* Washer, Lock 5/16	--	132394	Decal, Tine Shield
13	72110510	Bolt, Carriage 5/16-18 x 1-1/4	--	120075X	Decal, Warning (Leveling Shield)
14	124343X	Bracket, Shield Tine			
15	104101X	Shield, Side, Outer R.H.			
16	73220400	* Nut, Hex 1/4-20			
17	10040400	* Washer, Lock 1/4			
18	72040410	* Bolt, Carriage 1/4-20 x 1-1/4 Gr. 5			

\* STANDARD HARDWARE - - PURCHASE LOCALLY

NOTE: All component dimensions given in U.S. inches.  
1 inch = 25.4 mm

# REPAIR PARTS

5 HP 17" TILLER - - MODEL NUMBER WER500A

## TINE ASSEMBLY

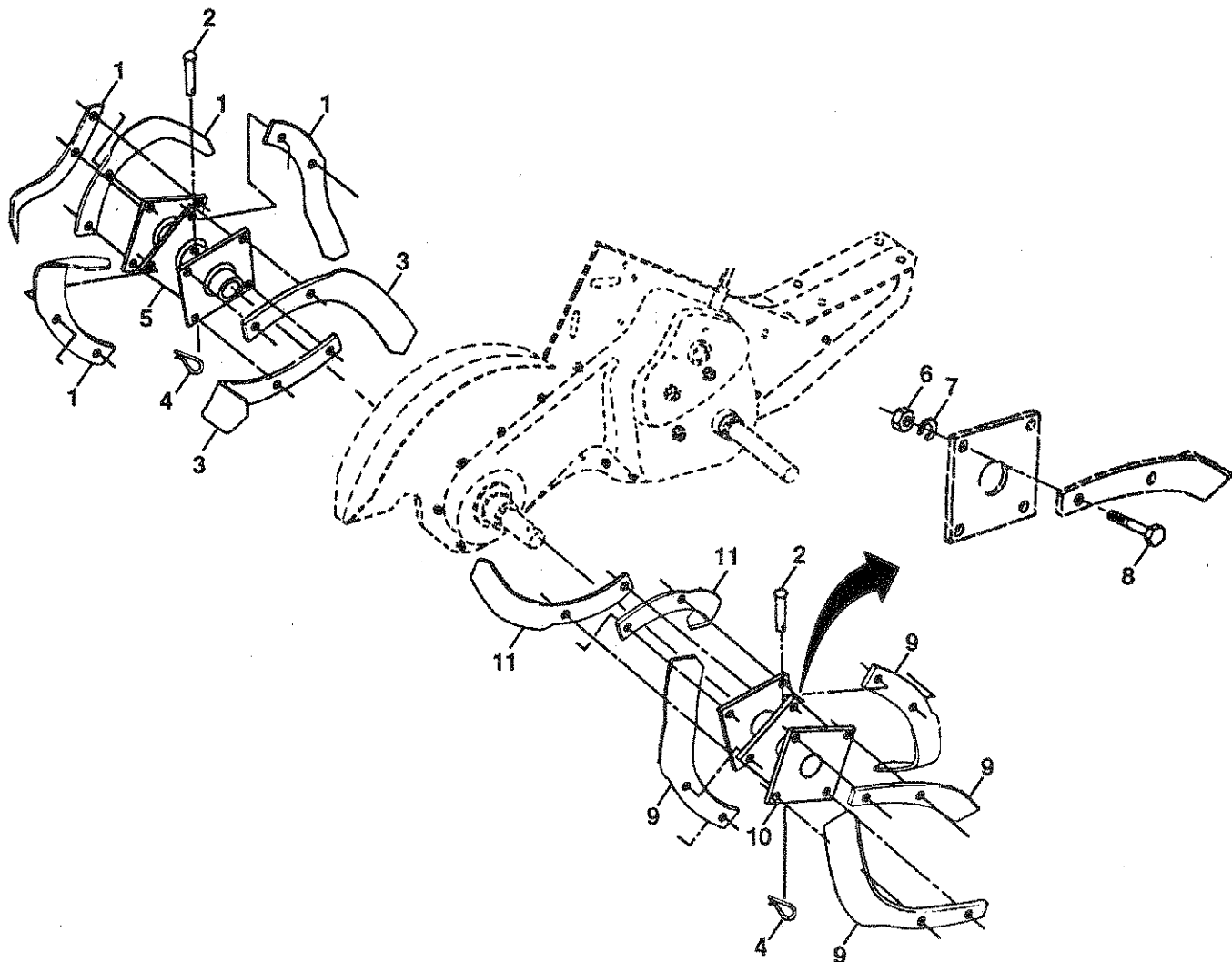

KEY NO.	PART NO.	DESCRIPTION
1	4459J	Tine, Outer, L.H.
2	132673	Pin, Shear
3	6554J	Tine, Inner, L.H.
4	3146R	* Clip, Hairpin
5	132727	Assembly, Hub and Plate, L.H.
6	73610600	Nut, Hex 3/8-24
7	10040600	* Washer, Lock 3/8

KEY NO.	PART NO.	DESCRIPTION
8	74610616	Bolt, Hex 3/8-24 x 1
9	4460J	Tine, Outer, R.H.
10	132728	Assembly, Hub and Plate, R.H.
11	6555J	Tine, Inner, R.H.

\* STANDARD HARDWARE--PURCHASE LOCALLY

NOTE: All component dimensions given in U.S. inches.  
1 inch = 25.4 mm

---

# SERVICE NOTES

---



## Free Manuals Download Website

<http://myh66.com>

<http://usermanuals.us>

<http://www.somanuals.com>

<http://www.4manuals.cc>

<http://www.manual-lib.com>

<http://www.404manual.com>

<http://www.luxmanual.com>

<http://aubethermostatmanual.com>

Golf course search by state

<http://golfingnear.com>

Email search by domain

<http://emailbydomain.com>

Auto manuals search

<http://auto.somanuals.com>

TV manuals search

<http://tv.somanuals.com>