

# WEIDER<sup>®</sup> 220

Model No. 831.159100

Serial No. \_\_\_\_\_

Write the serial number in the space above for reference.

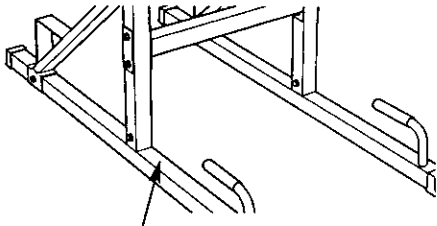

Serial Number Decal

EXERCISE  
EQUIPMENT

QUESTIONS

HELPLINE!

1-800-736-6879

SEARS, ROEBUCK AND CO.,  
HOFFMAN ESTATES, IL 60179

## ⚠ CAUTION

Read all precautions and instructions in this manual before using this equipment. Save this manual for future reference.

## USER'S MANUAL

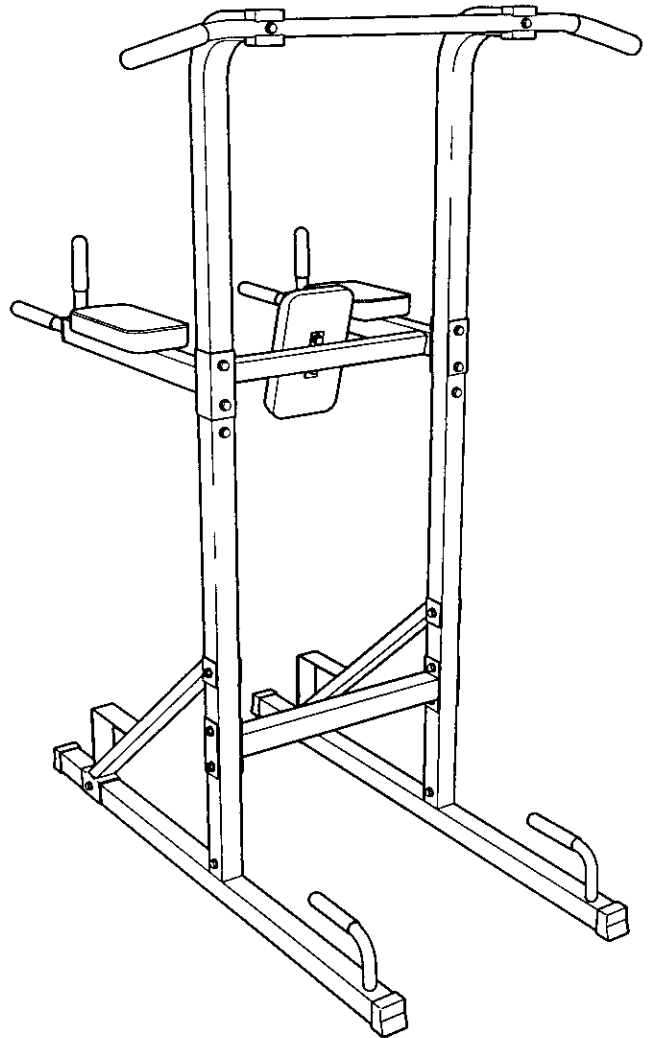

Visit our website at

[www.weiderfitness.com](http://www.weiderfitness.com)

new products, prizes,  
fitness tips, and much more!

# TABLE OF CONTENTS

WARNING DECAL PLACEMENT .....	2
IMPORTANT PRECAUTIONS .....	3
BEFORE YOU BEGIN .....	4
PART IDENTIFICATION CHART .....	5
ASSEMBLY .....	6
EXERCISE GUIDELINES .....	10
PART LIST .....	14
EXPLODED DRAWING .....	15
ORDERING REPLACEMENT PARTS .....	Back Cover
FULL 90 DAY WARRANTY .....	Back Cover

## WARNING DECAL PLACEMENT

The decal shown here has been applied to the exercise rack. If the decal is missing, or if it is not legible, please call our toll-free HELPLINE at 1-800-736-6879, Monday through Saturday, 7 a.m. until 7 p.m. Central Time (excluding holidays), to order a free replacement decal. Apply the replacement decal in the location shown.

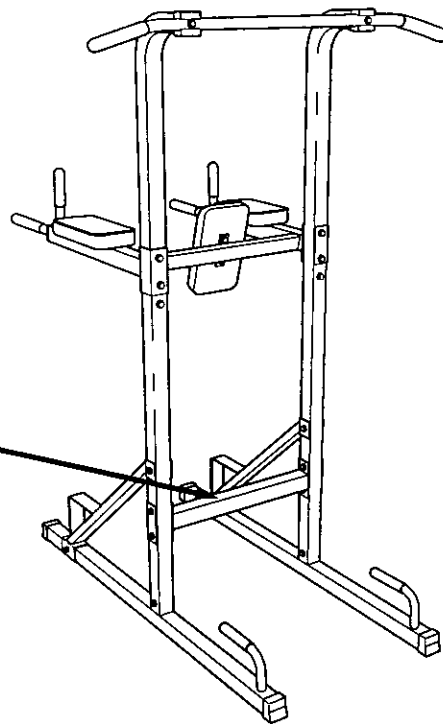
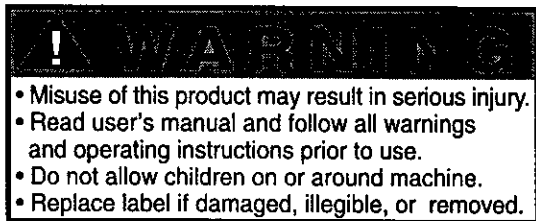

# IMPORTANT PRECAUTIONS

**▲ WARNING:** To reduce the risk of serious injury, read the following important precautions before using the exercise rack.

1. Read all instructions in this manual before using the exercise rack. Use the exercise rack only as described in this manual.
2. It is the responsibility of the owner to ensure that all users of the exercise rack are adequately informed of all precautions.
3. The exercise rack is intended for home use only. Do not use the exercise rack in any commercial, rental, or institutional setting.
4. Use the exercise rack only on a level surface. Cover the floor beneath the exercise rack to protect the floor.
5. Keep children under 12 and pets away from the exercise rack at all times.
6. Make sure all parts are properly tightened each time you use the exercise rack. Replace any worn parts immediately.
7. Always wear athletic shoes for foot protection while exercising.
8. The exercise rack is designed to support a maximum user weight of 250 pounds.
9. If you feel pain or dizziness at any time while exercising, stop immediately and begin cooling down.

**▲ WARNING:** Before beginning this or any exercise program, consult your physician. This is especially important for persons over the age of 35 or persons with pre-existing health problems. Read all instructions before using. SEARS assumes no responsibility for personal injury or property damage sustained by or through the use of this product.

# BEFORE YOU BEGIN

Thank you for selecting the versatile WEIDER® 220 exercise rack. The WEIDER® 220 is designed to help you develop the major muscle groups of the upper body. Whether your goal is a shapely figure, dramatic increase in muscle size and strength, or a healthier cardiovascular system, the WEIDER® 220 will help you achieve the specific results you want.

**For your benefit, read this manual carefully before using the WEIDER® 220 exercise rack.** If you have additional questions, please call our toll-free

HELPLINE at 1-800-736-6879, Monday through Saturday, 7 a.m. until 7 p.m. Central Time (excluding holidays). To help us assist you, please note the product model number and serial number before calling. The model number is 831.159100. The serial number can be found on a decal attached to the exercise rack (see the front cover of this manual).

Before reading further, please review the drawing below and familiarize yourself with the parts that are labeled.

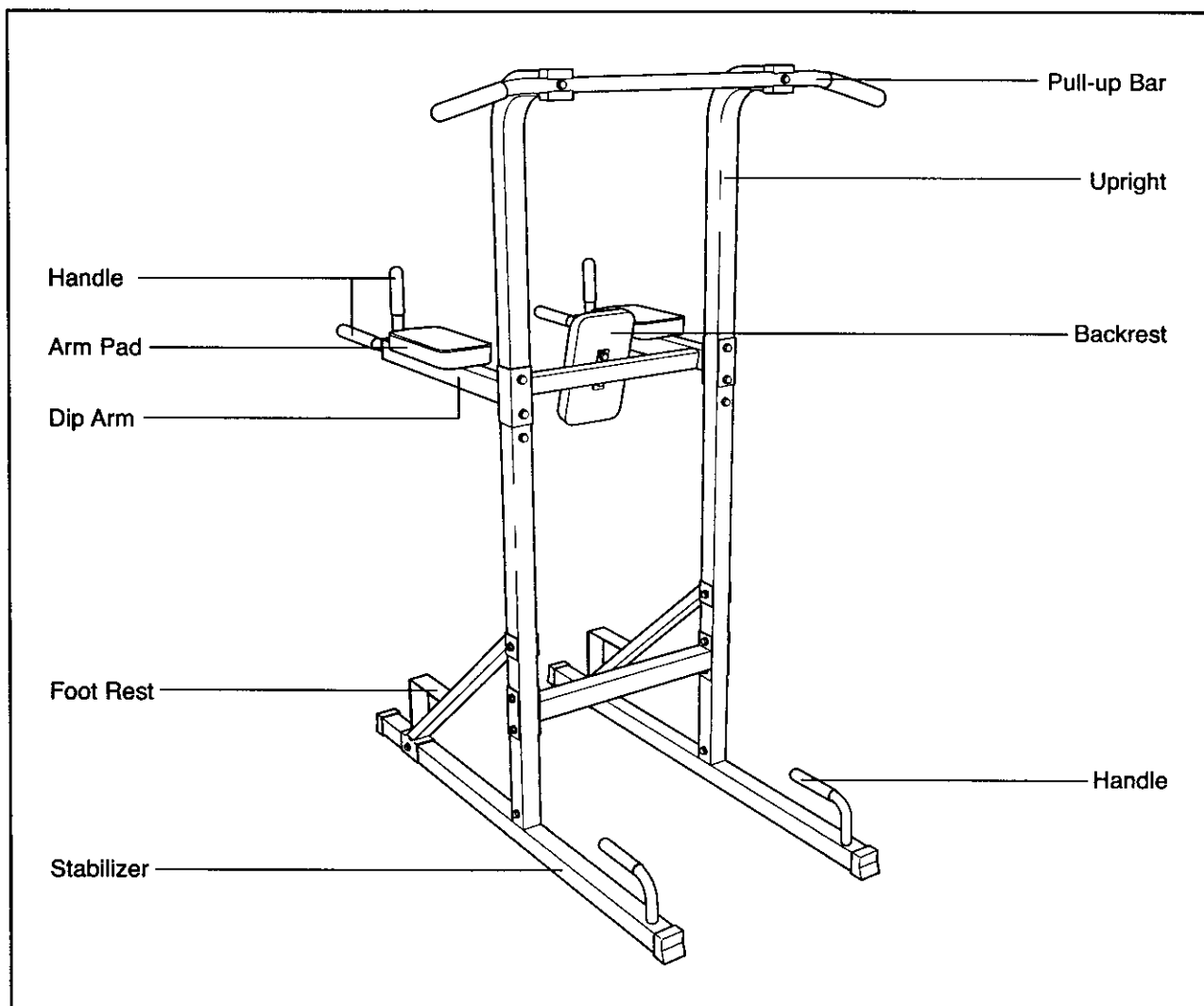

# PART IDENTIFICATION CHART

Refer to the drawings below to identify small parts used in assembly. The number in parentheses by each drawing is the key number of the part, from the PART LIST on page 14 of this manual. **Note: Some small parts may have been pre-attached. If a part is not in the parts bag, check to see if it has been pre-attached.**

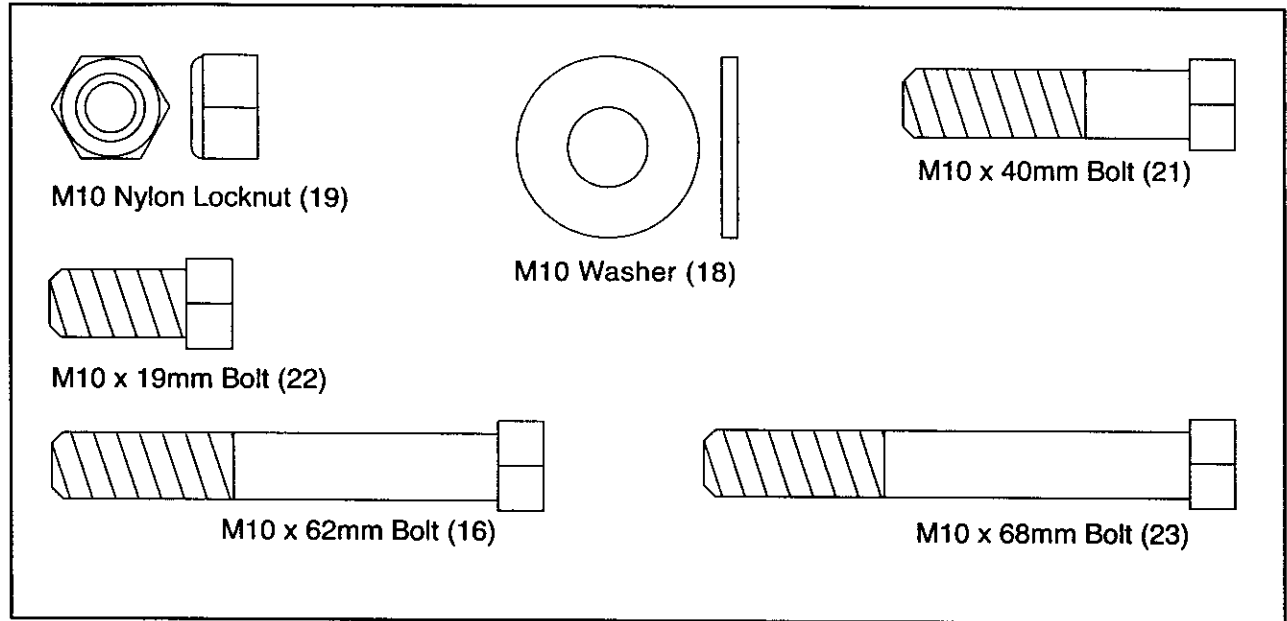

# ASSEMBLY

## Make Things Easier for Yourself

This manual is designed to ensure that the exercise rack can be assembled successfully by anyone. Most people find that by setting aside plenty of time, assembly will go smoothly.

Before beginning assembly, carefully read the following information and instructions:

- Assembly requires two people.
- For help identifying small parts, use the PART IDENTIFICATION CHART on page 5.
- Tighten all parts as you assemble them, unless instructed to do otherwise.
- As you assemble the exercise rack, make sure all parts are oriented as shown in the drawings.

- Place all parts in a cleared area and remove the packing materials. Do not dispose of the packing materials until assembly is completed.

The following tools (not included) are required for assembly:

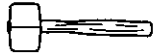
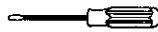
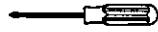
- Two adjustable wrenches 
- One rubber mallet 
- One standard screwdriver 
- One Phillips screwdriver 
- A small amount of soapy water.

Assembly will be more convenient if you have a socket set, a set of open-end or closed-end wrenches, or a set of ratchet wrenches.

1. Before beginning assembly, make sure you understand the information in the box above. Important: Some of the parts described in the assembly steps may be pre-assembled.

Press an Endcap (11) onto each end of the two Stabilizers (5). Slide a Handgrip (12) onto the handle of each Stabilizer.

2. Attach an Upright Base (3) to a Stabilizer (5) with two M10 x 19mm Bolts (22) and two M10 Washers (18). Do not tighten the Bolts yet.

Attach the other Upright Base (3) to the other Stabilizer (5) in the same manner.

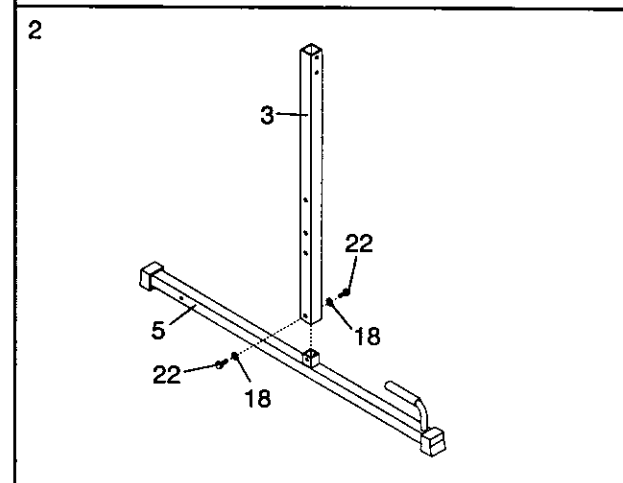
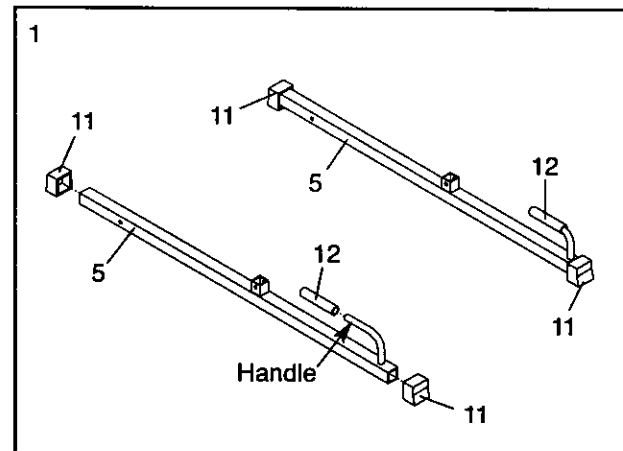

- Attach the Bottom Crossbar (15) to an Upright Base (3) with two M10 x 68mm Bolts (23) and two M10 Nylon Locknuts (19). **Note: Attach the Bottom Crossbar so that the indicated decal is in the indicated location. Do not tighten the Nylon Locknuts yet.**

Attach the Bottom Crossbar (15) to the other Upright Base (3) in the same manner.

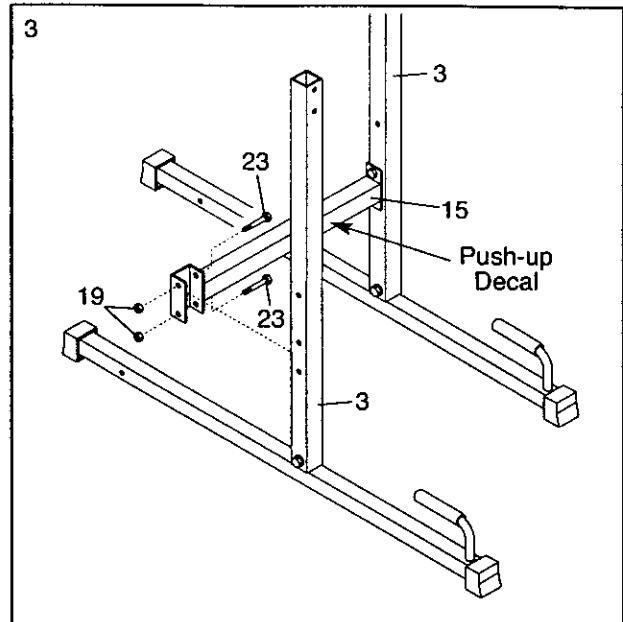

- Attach an Angled Support (7) to a Stabilizer (5) with an M10 x 68mm Bolt (23) and an M10 Nylon Locknut (19). Attach the Angled Support to the Upright Base (3) with another M10 x 68mm Bolt and an M10 Nylon Locknut. **Do not tighten the Nylon Locknuts yet.**

Attach the other Angled Support (7) to the other Stabilizer (5) and Upright Base (3) in the same manner.

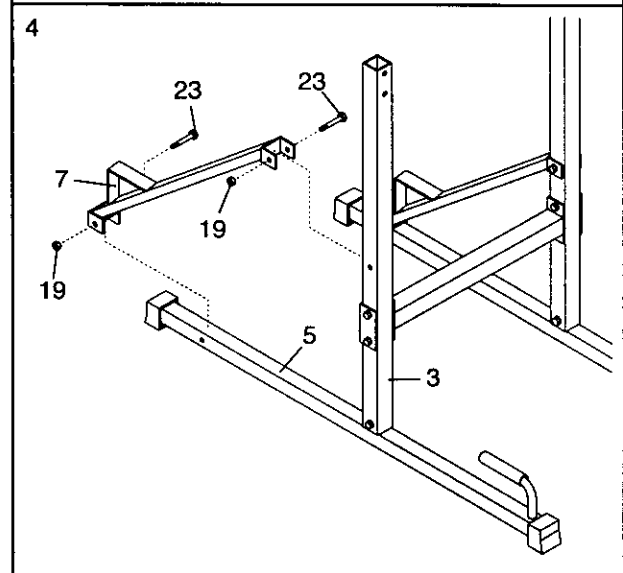

- Press a Rubber Endcap (14) onto the end of an Upright (2). Orient the Upright as shown and attach it to an Upright Base (3) with two M10 x 19mm Bolts (22) and two M10 Washers (18). **Note: The Bolts must be attached to the lowest set of holes in the Upright and Upright Base. Do not tighten the Bolts yet.**

Attach the other Upright (2) to the other Upright Base (3) in the same manner. **Note: Attach the Uprights so that the name and pull-up decals are in the indicated locations.**

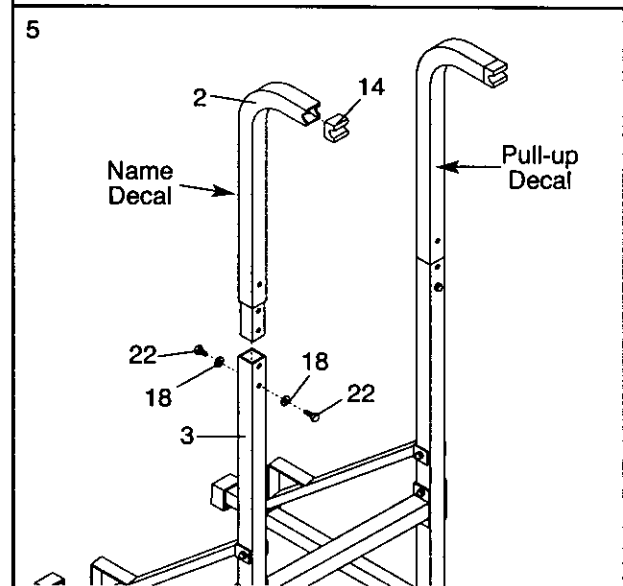

- Orient the Left Dip Arm (4) as shown, so that the large hole is on top. Attach the Left Dip Arm to the left Upright (2) with an M10 x 68mm Bolt (23) and an M10 Nylon Locknut (19). **Do not tighten the Nylon Locknut yet.**

Attach the Left Dip Arm (4) to the left Upright Base (3) with two M10 x 19mm Bolts (22). **Do not tighten the Bolts yet.**

Repeat this step with the Right Dip Arm (not shown).

- Orient the Top Crossbar (6) with the bracket on the side shown. Attach the Top Crossbar to each Dip Arm (4, 17) with two M10 x 68mm Bolts (23) and two M10 Nylon Locknuts (19). **Do not tighten the Nylon Locknuts yet.**

- Slide a Handgrip (12) onto each end of the Pull-up Bar (1). Attach the Pull-up Bar to the Uprights (2) with two M10 x 40mm Bolts (21) and two M10 Washers (18).

**Tighten all of the Bolts and Nylon Locknuts used in steps 2–8.**

- Attach a Handle (8) to each Dip Arm (4, 17) with an M10 x 19mm Bolt (22) and an M10 Washer (18). Slide a Handgrip (12) onto each Handle.

Slide an Outer Cap (13) and a Handgrip (12) onto each Dip Arm (4, 17).

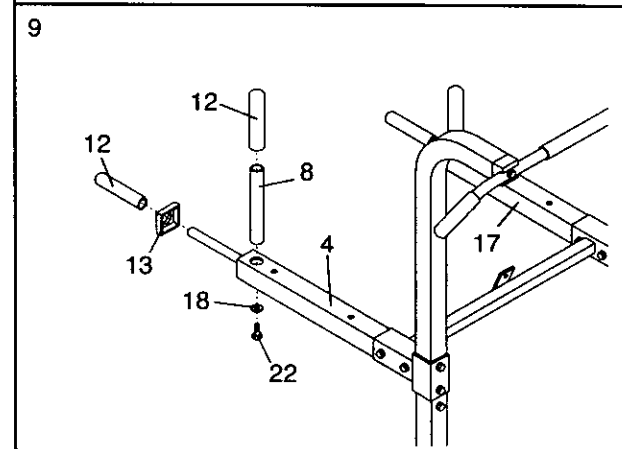
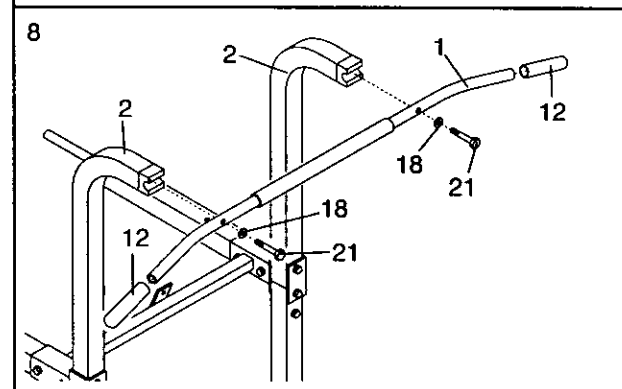
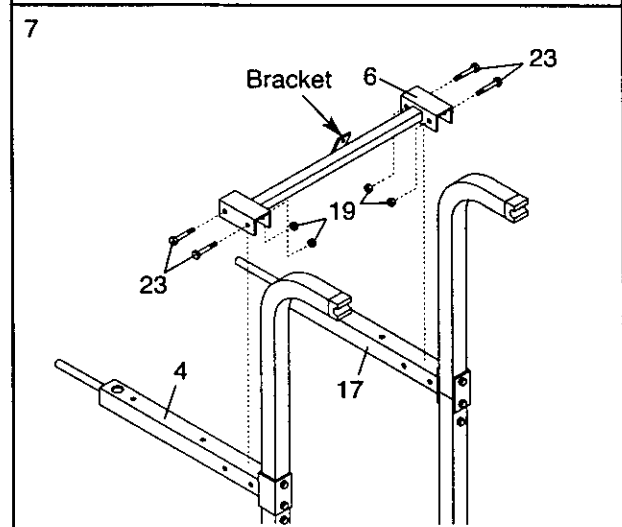
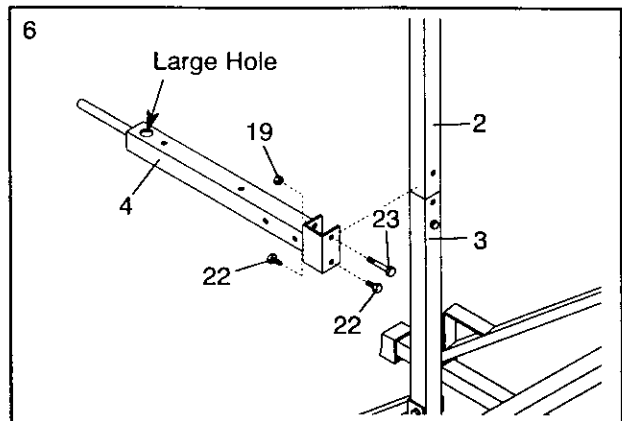



10. Attach an Arm Pad (10) to each Dip Arm (4, 17) with two M10 x 62mm Bolts (16) and two M10 Washers (18).

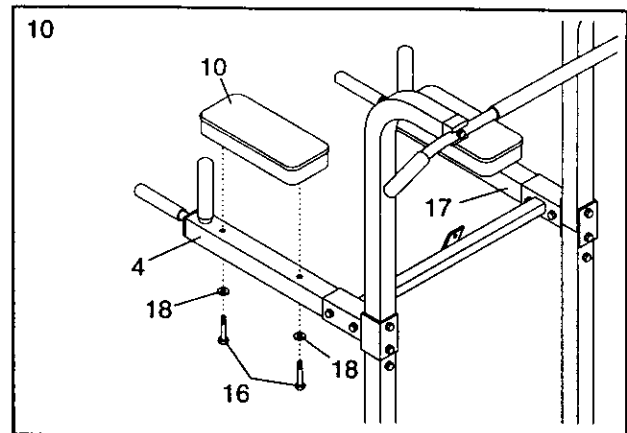

11. Attach the Backrest (9) to the Top Crossbar (6) with two M10 x 19mm Bolts (19).

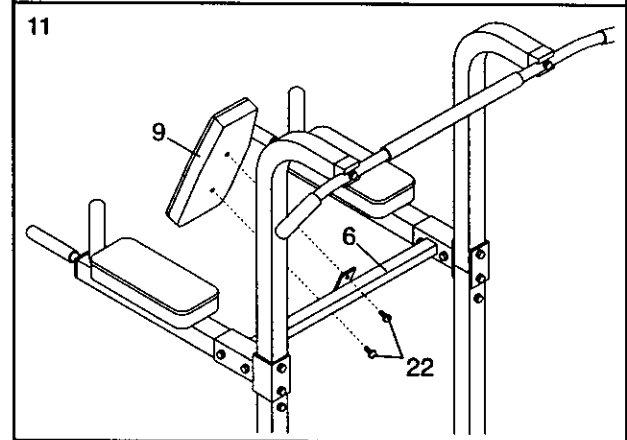

12. Make sure that all parts have been properly tightened before you use the exercise rack.

---

# EXERCISE GUIDELINES

## THE FOUR BASIC TYPES OF WORKOUTS

### Muscle Building

To increase the size and strength of your muscles, push them close to their maximum capacity. Your muscles will continually adapt and grow as you progressively increase the intensity of your exercise. You can adjust the intensity level of an individual exercise by changing the number of repetitions or sets performed. (A "repetition" is one complete cycle of an exercise, such as one sit-up. A "set" is a series of repetitions.)

Begin with 3 sets of 8 repetitions for each exercise you perform. Rest for 3 minutes after each set. When you can complete 3 sets of 12 repetitions without difficulty, increase the amount of weight.

### Toning

You can tone your muscles by pushing them to a moderate percentage of their capacity. Increase the number of repetitions in each set. Complete as many sets of 15 to 20 repetitions as possible without discomfort. Rest for 1 minute after each set. Work your muscles by completing more sets.

### Weight Loss

To lose weight, increase the number of repetitions in each set. Exercise for 20 to 30 minutes, resting for a maximum of 30 seconds between sets.

### Cross Training

Cross training is an efficient way to get a complete and well-balanced fitness program. An example of a balanced program is:

- Plan weight training workouts on Monday, Wednesday, and Friday.
- Plan 20 to 30 minutes of aerobic exercise, such as cycling or swimming, on Tuesday and Thursday.
- Rest from both weight training and aerobic exercise for at least one full day each week to give your body time to regenerate.

The combination of weight training and aerobic exercise will reshape and strengthen your body, and develop your heart and lungs.

## PERSONALIZING YOUR EXERCISE PROGRAM

Determining the exact length of time for each workout, as well as the number of repetitions or sets completed, is an individual matter. It is important to avoid overdoing it during the first few months of your exercise program. You should progress at your own pace and be sensitive to your body's signals. If you experience pain

or dizziness at any time while exercising, stop immediately and begin cooling down. Find out what is wrong before continuing. Remember that adequate rest and a proper diet are important factors in any exercise program.

### WARMING UP

Begin each workout with 5 to 10 minutes of stretching and light exercise to warm up. Warming up prepares your body for more strenuous exercise by increasing circulation, raising your body temperature and delivering more oxygen to your muscles.

### WORKING OUT

Each workout should include 6 to 10 different exercises. Select exercises for every major muscle group, emphasizing areas that you want to develop most. To give balance and variety to your workouts, vary the exercises from session to session.

Schedule your workouts for the time of day when your energy level is the highest. Each workout should be followed by at least one day of rest. Once you find the schedule that is right for you, stick with it.

### EXERCISE FORM

Maintaining proper form is an essential part of an effective exercise program. This requires moving through the full range of motion for each exercise, and moving only the appropriate parts of the body. Exercising in an uncontrolled manner will leave you feeling exhausted.

The repetitions in each set should be performed smoothly and without pausing. The exertion stage of each repetition should last about half as long as the return stage. Proper breathing is important. Exhale during the exertion stage of each repetition and inhale during the return stroke. Never hold your breath.

Rest for a short period of time after each set. The ideal resting periods are:

- Rest for three minutes after each set for a muscle building workout.
- Rest for one minute after each set for a toning workout.
- Rest for 30 seconds after each set for a weight loss workout.

Plan to spend the first couple of weeks familiarizing yourself with the equipment and learning the proper form for each exercise.

## COOLING DOWN

End each workout with 5 to 10 minutes of stretching. Include stretches for both your arms and legs. Move slowly as you stretch and do not bounce. Ease into each stretch gradually and go only as far as you can without strain. Stretching at the end of each workout is an effective way to increase flexibility.

## STAYING MOTIVATED

For motivation, keep a record of each workout. The chart on pages 12 and 13 of this manual can be pho-

tocopied and used to schedule and record your workouts. List the date, the exercises performed and the numbers of sets and repetitions completed. Record your weight and key body measurements at the end of every month. Remember, the key to achieving the greatest results is to make exercise a regular and enjoyable part of your everyday life.

## MUSCLE CHART

- A. Sternomastoid (neck)
- B. Pectoralis Major (chest)
- C. Biceps (front of arm)
- D. Obliques (waist)
- E. Brachioradials (forearm)
- F. Hip Flexors (upper thigh)
- G. Abductor (outer thigh)
- H. Quadriceps (front of thigh)
- I. Sartorius (front of thigh)
- J. Tibialis Anterior (front of calf)
- K. Soleus (front of calf)
- L. Rectus Abdominus (stomach)
- M. Adductor (inner thigh)
- N. Trapezius (upper back)
- O. Rhomboideus (upper back)
- P. Deltoid (shoulder)
- Q. Triceps (back of arm)
- R. Latissimus Dorsi (mid back)
- S. Spinae Erectors (lower back)
- T. Gluteus Medius (hip)
- U. Gluteus Maximus (buttocks)
- V. Hamstring (back of leg)
- W. Gastrocnemius (back of calf)

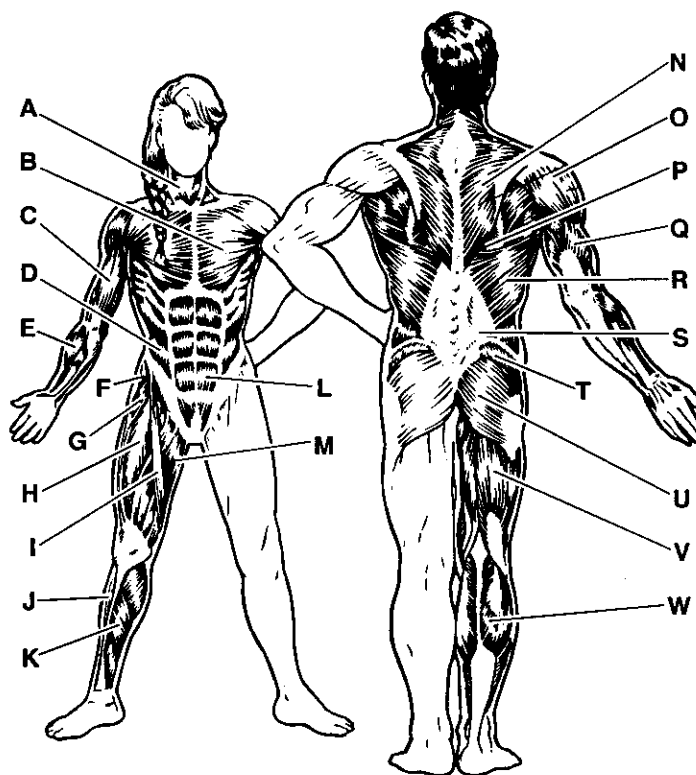

<b>MONDAY</b> Date: _____ / ____ / ____	<b>EXERCISE</b>	<b>SETS</b>	<b>REPS</b>

**TUESDAY      AEROBIC EXERCISE**  
Date: \_\_\_\_\_ / \_\_\_\_ / \_\_\_\_

<b>WEDNESDAY</b> Date: _____ / ____ / ____	<b>EXERCISE</b>	<b>SETS</b>	<b>REPS</b>

**THURSDAY      AEROBIC EXERCISE**  
Date: \_\_\_\_\_ / \_\_\_\_ / \_\_\_\_

<b>FRIDAY</b> Date: _____ / ____ / ____	<b>EXERCISE</b>	<b>SETS</b>	<b>REPS</b>

Make photocopies of this page for scheduling and recording your workouts.

<b>MONDAY</b> Date: / /	<b>EXERCISE</b>	<b>SETS</b>	<b>REPS</b>

**TUESDAY AEROBIC EXERCISE**

Date: / /

<b>WEDNESDAY</b> Date: / /	<b>EXERCISE</b>	<b>SETS</b>	<b>REPS</b>

**THURSDAY AEROBIC EXERCISE**

Date: / /

<b>FRIDAY</b> Date: / /	<b>EXERCISE</b>	<b>SETS</b>	<b>REPS</b>

Make photocopies of this page for scheduling and recording your workouts.

# PART LIST—Model No. 831.159100

R0402A

Key No.	Qty.	Description	Key No.	Qty.	Description
1	1	Pull-up Bar	14	2	Rubber Endcap
2	2	Upright	15	1	Bottom Crossbar
3	2	Upright Base	16	4	M10 x 62mm Bolt
4	1	Left Dip Arm	17	1	Right Dip Arm
5	2	Stabilizer	18	16	M10 Washer
6	1	Top Crossbar	19	14	M10 Nylon Locknut
7	2	Angle Support	20	2	Rubber Pad
8	2	Handle	21	2	M10 x 40mm Bolt
9	1	Backrest	22	16	M10 x 19mm Bolt
10	2	Arm Pad	23	14	M10 x 68mm Bolt
11	4	Endcap	24	1	Foam Grip
12	8	Handgrip	#	1	User's Manual
13	2	Outer Cap			

Note: “#” indicates a non-illustrated part. Specifications are subject to change without notice. See the back cover of this manual for information about ordering replacement parts.

# EXPLODED DRAWING—Model No. 831.159100

R0402A

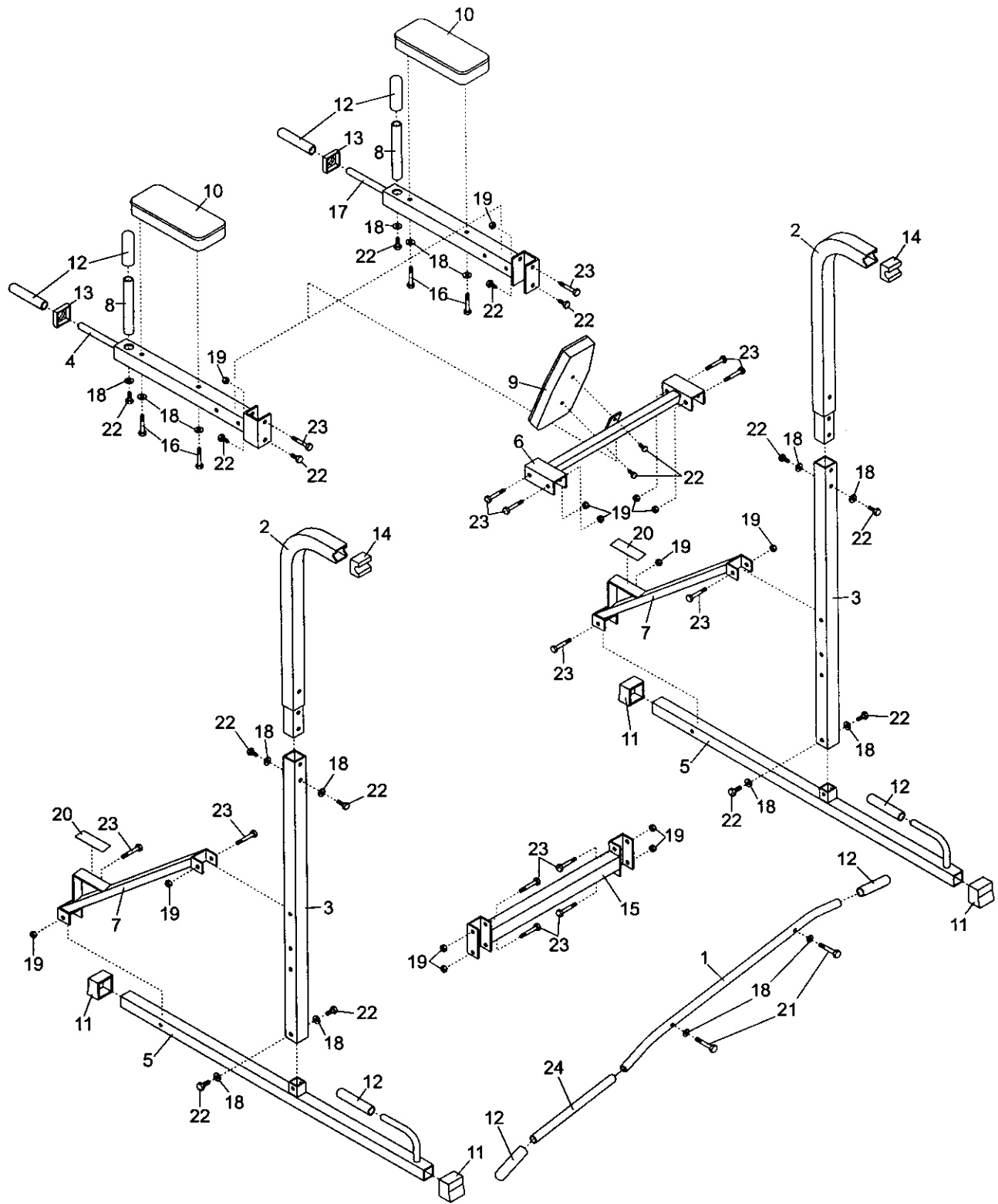



Model No. 831.159100

## QUESTIONS?

If you find that:

- you need help assembling or operating the WEIDER® 220 exercise rack
- a part is missing
- or you need to schedule repair service

call our toll-free HELPLINE

**1-800-736-6879**

Monday–Saturday, 7 am–7 pm  
Central Time (excluding holidays)

## REPLACEMENT PARTS

If parts become worn and need to be replaced, call the following toll-free number

**1-800-FON-PART**  
**(1-800-366-7278)**

The model number and serial number of your WEIDER® 220 exercise rack are listed on a decal attached to the frame. See the front cover of this manual to find the location of the decal.

All replacement parts are available for immediate purchase or special order when you visit your nearest SEARS Service Center. To request service or to order parts by telephone, call the toll-free numbers listed at the left.

When requesting help or service, or ordering parts, please be prepared to provide the following information:

- The MODEL NUMBER of the product (831.159100)
- The NAME of the product (WEIDER® 220 exercise rack)
- The KEY NUMBER and DESCRIPTION of the PART (see the PART LIST and EXPLODED DRAWING on pages 14 and 15 of this manual).

SEARS, ROEBUCK AND CO., HOFFMAN ESTATES, IL 60179

## FULL 90 DAY WARRANTY

For 90 days from the date of purchase, if failure occurs due to defect in material or workmanship in this SEARS RACK EXERCISER, contact the nearest SEARS Service Center throughout the United States and SEARS will repair or replace the RACK EXERCISER, free of charge.

This warranty does not apply when the RACK EXERCISER is used commercially or for rental purposes.

This warranty gives you specific legal rights, and you may also have other rights which vary from state to state.

SEARS, ROEBUCK AND CO., DEPT. 817WA, HOFFMAN ESTATES, IL 60179



## Free Manuals Download Website

<http://myh66.com>

<http://usermanuals.us>

<http://www.somanuals.com>

<http://www.4manuals.cc>

<http://www.manual-lib.com>

<http://www.404manual.com>

<http://www.luxmanual.com>

<http://aubethermostatmanual.com>

Golf course search by state

<http://golfingnear.com>

Email search by domain

<http://emailbydomain.com>

Auto manuals search

<http://auto.somanuals.com>

TV manuals search

<http://tv.somanuals.com>