



WEIDER[®] **144**

Model No. WEBE06691

Serial No. _____

Write the serial number in the space above for reference.

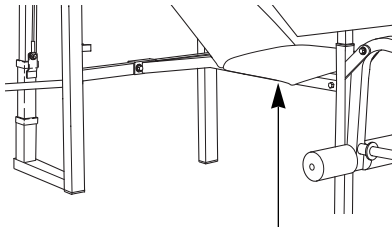

Serial Number Decal (under seat)

USER'S MANUAL

QUESTIONS?

As a manufacturer, we are committed to providing complete customer satisfaction. If you have questions, or if there are missing parts, we will guarantee complete satisfaction through direct assistance from our factory.

TO AVOID UNNECESSARY DELAYS, PLEASE CALL DIRECT TO OUR TOLL-FREE CUSTOMER HOT LINE. The trained technicians on our customer hot line will provide immediate assistance, free of charge to you.

CUSTOMER HOT LINE:

1-800-999-3756

Mon.–Fri., 6 a.m.–6 p.m. MST

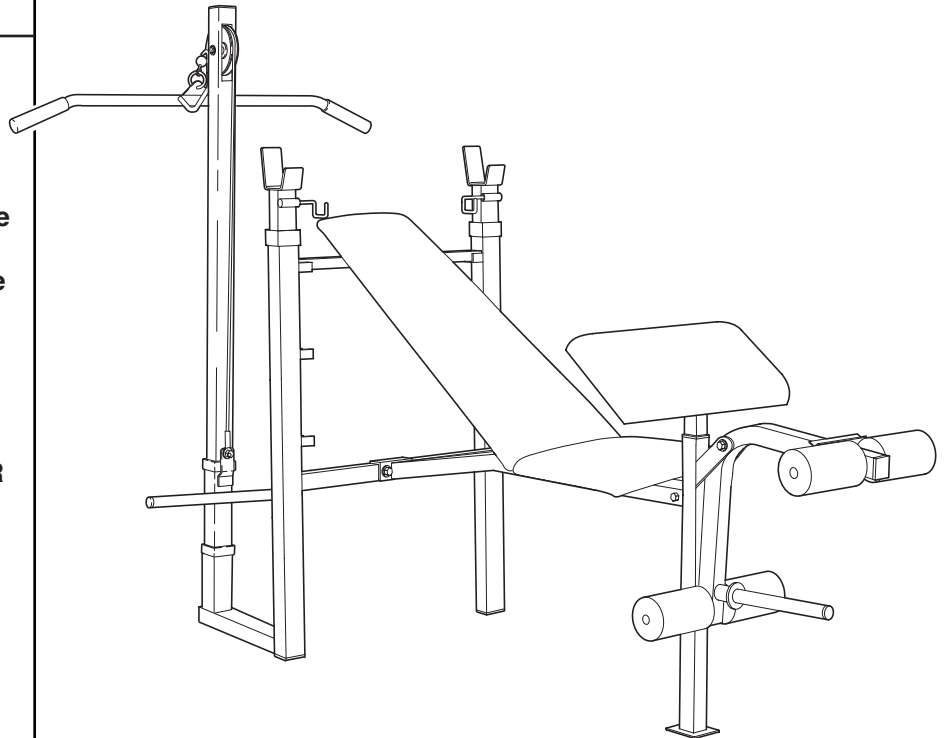

⚠ CAUTION

Read all precautions and instructions in this manual before using this equipment. Save this manual for future reference.



Visit our website at

www.weiderfitness.com

new products, prizes,
fitness tips, and much more!

Table of Contents

WARNING DECAL PLACEMENT	2
IMPORTANT PRECAUTIONS	3
BEFORE YOU BEGIN	4
PART IDENTIFICATION CHART	5
ASSEMBLY	6
USING THE WEIGHT BENCH	10
EXERCISE GUIDELINES	12
PART LIST	14
EXPLODED DRAWING	15
ORDERING REPLACEMENT PARTS	Back Cover
LIMITED WARRANTY	Back Cover

Warning Decal Placement

The decal shown at the right has been placed on the weight bench. If the decal is missing, or if it is not legible, please call our Customer Service Department toll-free at 1-800-999-3756, Monday through Friday, 6 a.m. until 6 p.m. Mountain Time, to order a free replacement decal. Apply the replacement decal in the location shown.

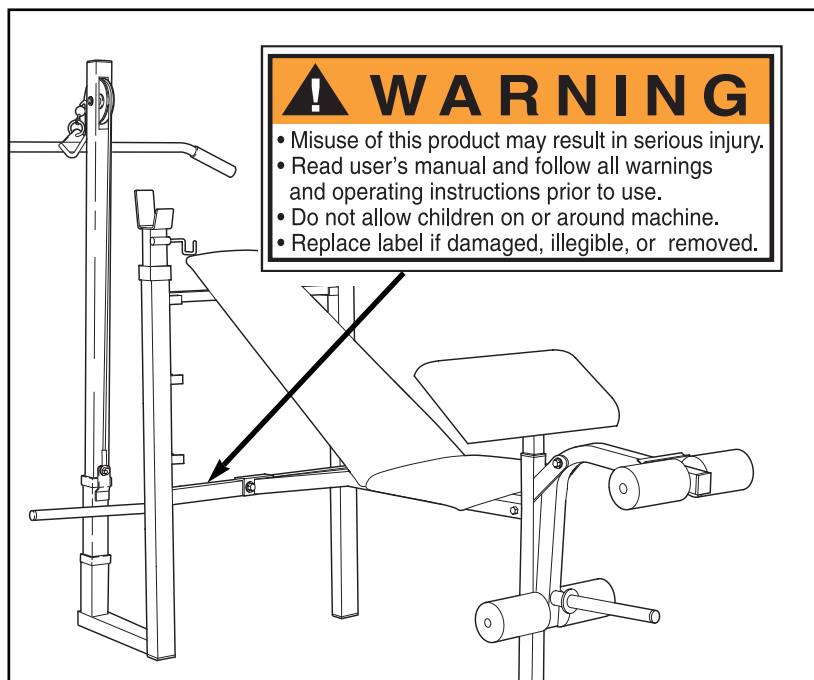

Important Precautions

⚠ WARNING: To reduce the risk of serious injury, read the following important precautions before using the weight bench.

1. Read all instructions in this manual before using the weight bench. Use the weight bench only as described in this manual.
2. It is the responsibility of the owner to ensure that all users of the weight bench are adequately informed of all precautions.
3. The weight bench is intended for home use only. Do not use the weight bench in any commercial, rental, or institutional setting.
4. Use the weight bench only on a level surface. Cover the floor beneath the weight bench for protection.
5. Inspect and tighten all parts each time you use the weight bench. Replace any worn parts immediately.
6. Keep children under 12 and pets away from the weight bench at all times.
7. Keep hands and feet away from moving parts.
8. Always wear athletic shoes for foot protection while exercising.
9. Do not use a barbell (not included) longer than five feet with the weight bench.
10. Always make sure there is an equal amount of weight on each side of your barbell.
11. The weight bench is designed to support a maximum of 360 pounds, including the user, a barbell and weights. Do not place more than 110 pounds, including a barbell and weights, on the weight rests. Do not place more than 110 pounds on the weight carriage.
12. When using the backrest, make sure the support tube is fully inserted into the adjustment brackets on the uprights.
13. Always remove the lat tower or curl post from the front leg before performing leg curl or leg extension exercises with the leg lever (see page 11).
14. When performing an exercise during which you are sitting on the bench with your back to the lat tower, make sure there is plenty of space between your back and the weight carriage. Always lower the weight carriage in a controlled manner. Never let the weight carriage drop.
15. Always set both weight rests at the same height. The large threaded knob must always be inserted through both the weight rest and upright and firmly tightened. Never tighten the knob into an upright and then set a weight rest in the upright on top of the knob.
16. If you feel pain or dizziness at any time while exercising, stop immediately and begin cooling down.
17. When you are using the leg lever, place a barbell (not included) with the same amount of weight on the weight rests to balance the bench.
18. When you are changing weights, always secure the barbell with the barbell hooks to help prevent it from falling off the bench.

⚠ WARNING: Before beginning this or any exercise program, consult your physician. This is especially important for persons over the age of 35 or persons with pre-existing health problems. Read all instructions before using. ICON assumes no responsibility for personal injury or property damage sustained by or through the use of this product.

Before You Begin

Thank you for selecting the versatile WEIDER® 144 weight bench. The WEIDER® 144 weight bench is designed to let you develop every major muscle group of the body. Whether your goal is a shapely figure, dramatic muscle size and strength, or a healthier cardiovascular system, the WEIDER® 144 weight bench will help you to achieve the specific results you want.

For your benefit, read this manual carefully before using the WEIDER® 144 weight bench. If you have additional questions, please call our Customer Service Department toll-free at 1-800-999-3756, Monday

through Friday, 6 a.m. until 6 p.m. Mountain Standard Time (excluding holidays). To help us assist you, please note the product model number and serial number before calling. The model number is WEBE06691. The serial number can be found on a decal attached to the weight bench (see the front cover of this manual).



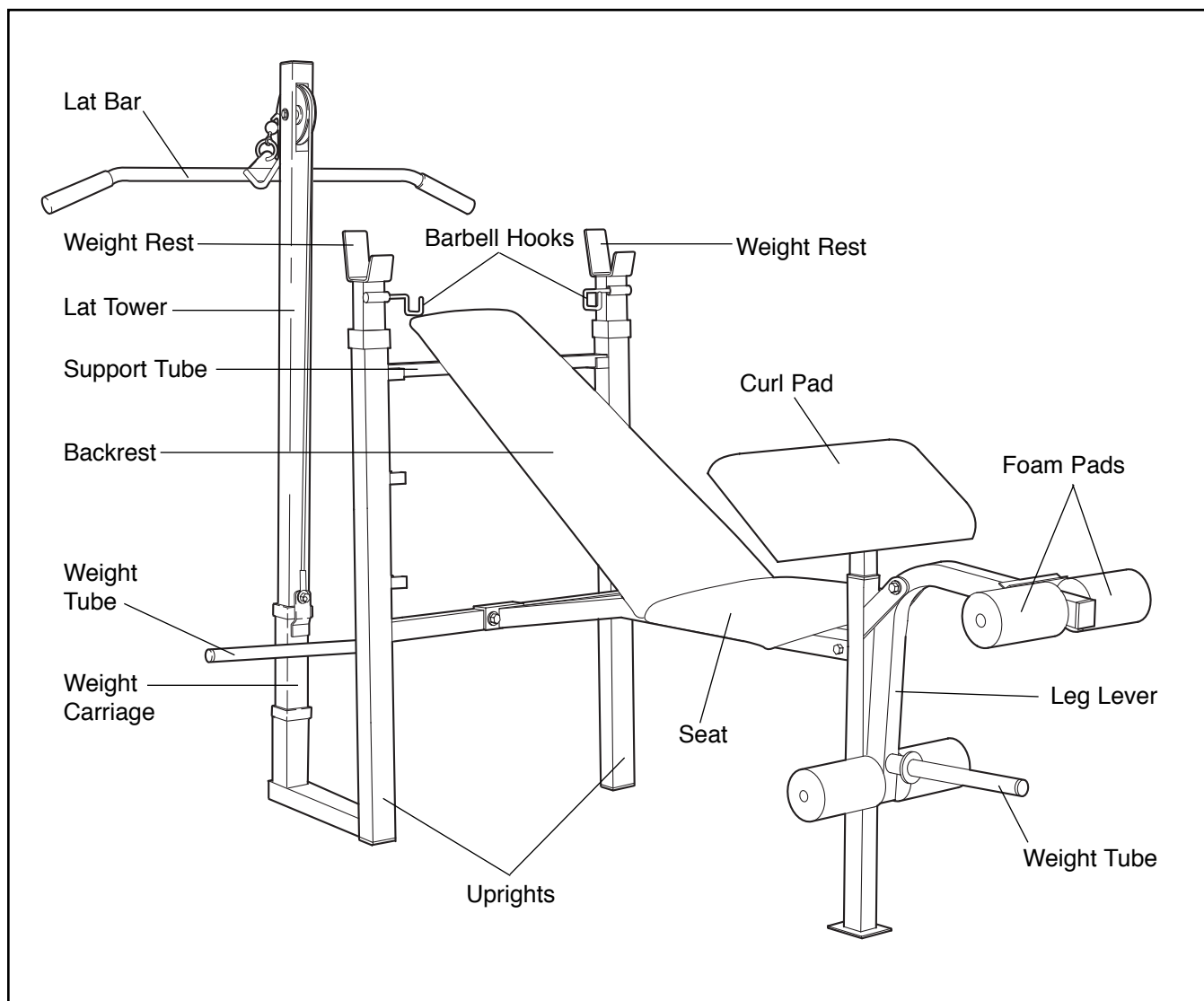





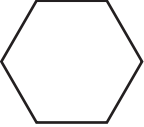
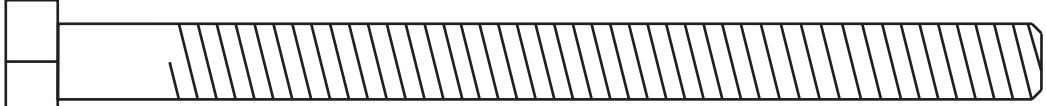
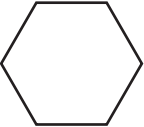
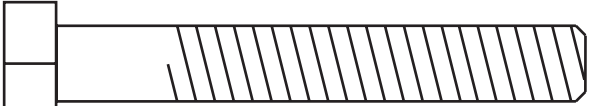
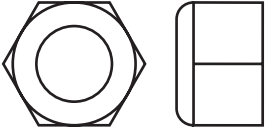
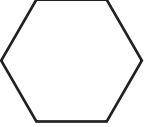
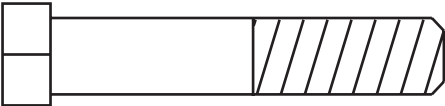
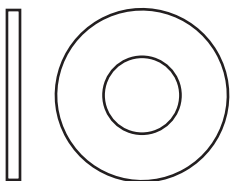

Before reading further, please review the drawing below and familiarize yourself with the parts that are labeled.

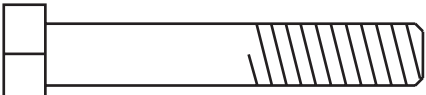
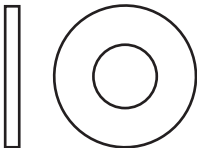

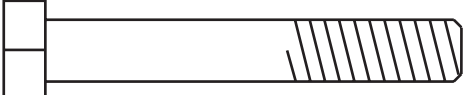
Part Identification Chart

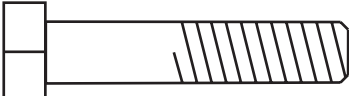
This chart is provided to help you identify the small parts used in assembly. **Important: Some parts may have been pre-assembled for shipping purposes. If you cannot find a part in the parts bags, check**

to see if it has been pre-assembled. The number in parenthesis below each part refers to the key number of the part. The second number refers to the quantity needed for assembly.



		
	M10 x 130mm Bolt (9)-1	
		
	M10 x 70mm Bolt (26)-5	M10 Nylon Locknut (30)-7
		
	M10 x 52mm Bolt (35)-1	M10 Washer (29)-6
		
	M8 x 50mm Bolt (44)-2	M8 Washer (17)-14
		
	M8 x 55mm Bolt (25)-2	
		
	M8 x 40mm Bolt (27)-8	M8 Nylon Locknut (34)-6
		
	M6 x 16mm Screw (24)-2	

Assembly

Before beginning assembly, carefully read the following information and instructions:

- Place all parts in a cleared area and remove the packing materials; do not dispose of the packing materials until assembly is completed.
- Tighten all parts as you assemble them, unless instructed to do otherwise.
- For help identifying the small parts used in assembly, use the PART IDENTIFICATION CHART on the page 5.
- As you assemble the weight bench, be sure that all parts are oriented as shown in the drawings.

THE FOLLOWING TOOLS (NOT INCLUDED) ARE REQUIRED FOR ASSEMBLY:

- **Two (2) adjustable wrenches** 
- **One (1) rubber mallet** 
- **One (1) standard screwdriver** 
- **Lubricant, such as grease or petroleum jelly, and soapy water.**

Assembly will be more convenient if you have the following tools: A socket set, a set of open-end or closed-end wrenches or a set of ratchet wrenches.

1. Before assembling this product, make sure you understand the information in the box above.

Press a 50mm x 50mm Square Inner Cap (36) into the lower end of each Upright (1, 15). Press a 45mm x 45mm Square Inner Cap (28) into the base of the Right Upright (1).

Orient the Crossbar (3) with the warning decal facing up as shown. Attach the Crossbar to the Left Upright (15) with two M10 x 70mm Bolts (26), a Support Plate (14) and two M10 Nylon Locknuts (30). **The Upright must be oriented as shown.**

Attach the Crossbar (3) to Right Upright (1) in the same manner.

2. Attach the Frame (2) to the welded bracket on the Front Leg (8) with two M8 x 50mm Bolts (44), four M8 Washers (17), and two M8 Nylon Locknuts (34).

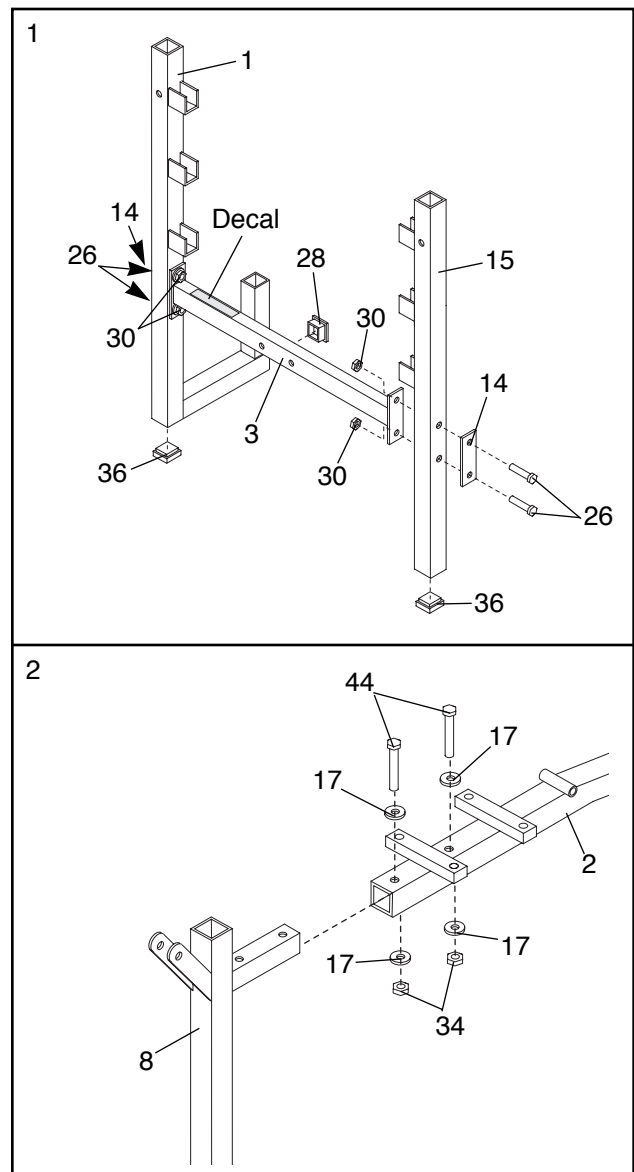

- Attach the Frame (2) to the Crossbar (3) with two M8 x 55mm Bolts (25) and two M8 Nylon Locknuts (34).

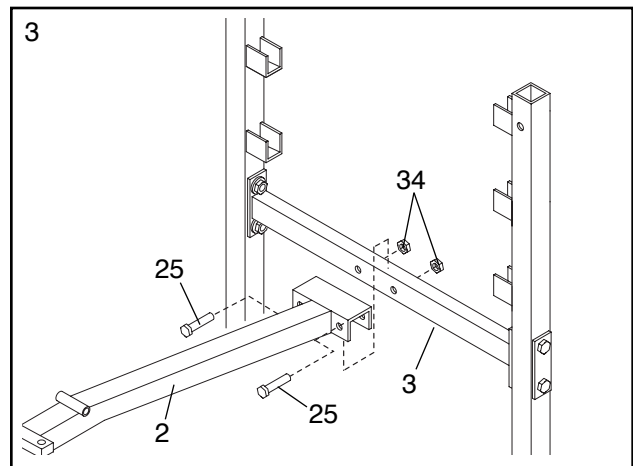

- Press a 50mm Square Bushing (31) onto each Upright (1, 15) and tap them in place with a rubber mallet.

Slide a Weight Rest (16) into the Right Upright (1). Align one of the adjustment holes in the Weight Rest with the adjustment hole in the Upright. Tighten the Large Threaded Knob (20) into the adjustment hole in the Upright. Attach the other Weight Rest (16) to the Left Upright (15) in the same manner.

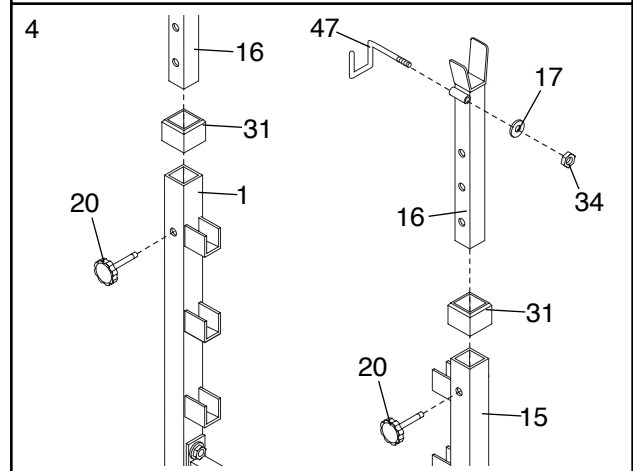

Attach the Left Barbell Hook (47) to the left Weight Rest (16) with an M8 Washer (17) and an M8 Nylon Locknut (34). **Note: Make sure that the Barbell Hook is on the inside of the Weight Rest.** Attach the Right Barbell Hook (46, not shown) to the other Weight Rest in the same manner.

- Tap a 38mm Square Inner Cap (32) into each end of the Leg Lever (4).

Tap a 25.4mm Round Inner Cap (21) into each end of the weight tube.

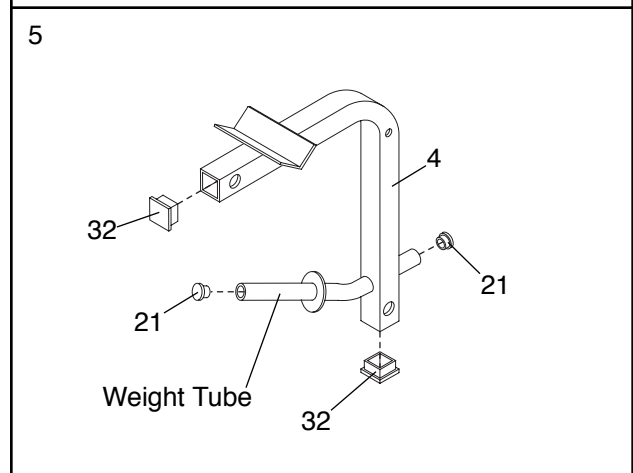

- Lubricate the M10 x 70mm Bolt (26). Attach the Leg Lever (4) to the Front Leg (8) with the Bolt, two M10 Washers (29) and an M10 Nylon Locknut (30).

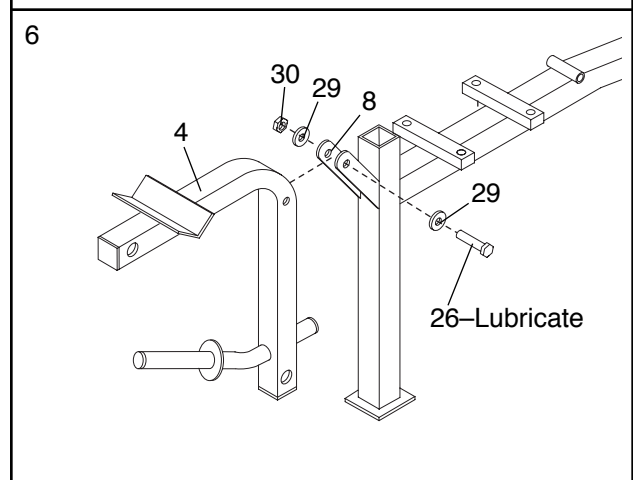

- Press two 19mm Round Inner Caps (33) into each Pad Tube (10).

Insert the Pad Tubes (10) into the holes in the Leg Lever (4). Slide two Foam Pads (22) onto each Pad Tube.

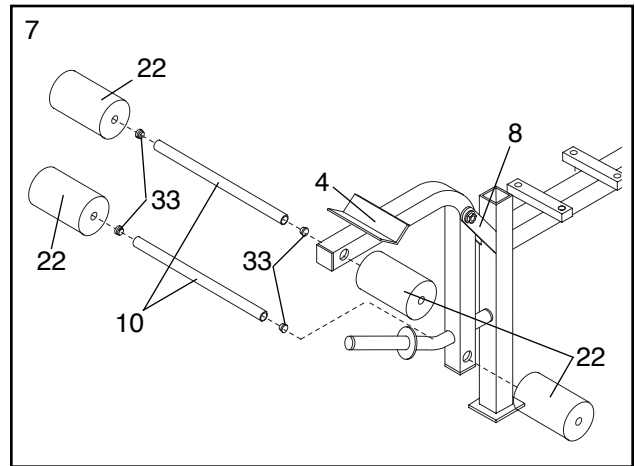

- Press a 1" Square Inner Cap (18) into the indicated end of each Backrest Tube (5).

Attach each Backrest Tube (5) to the Backrest (6) with two M8 x 40mm Bolts (27) and two M8 Washers (17). **The Backrest Tubes must be oriented as shown. Do not tighten the four Bolts yet.**

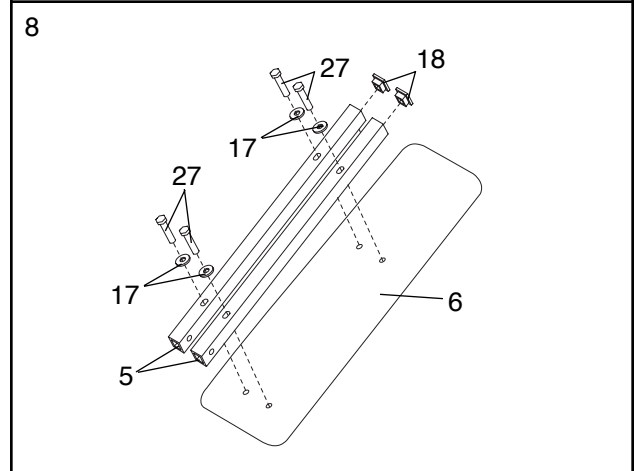

- Press a 1" Square Inner Cap (18) into each end of the Support Tube (7). Set the Support Tube into the highest set of adjustment brackets on the Uprights (1, 15).

Lubricate the M10 x 130mm Bolt (9). Attach the Backrest Tubes (5) to the Frame (2) with the Bolt, two M10 Washers (29) and an M10 Nylon Locknut (30). **Do not overtighten the Nylon Locknut.**

Rest the Backrest (6) on the Support Tube (7).

Tighten the four M8 x 40mm Bolts (27) securing the support tubes to the seat (see Step 8).

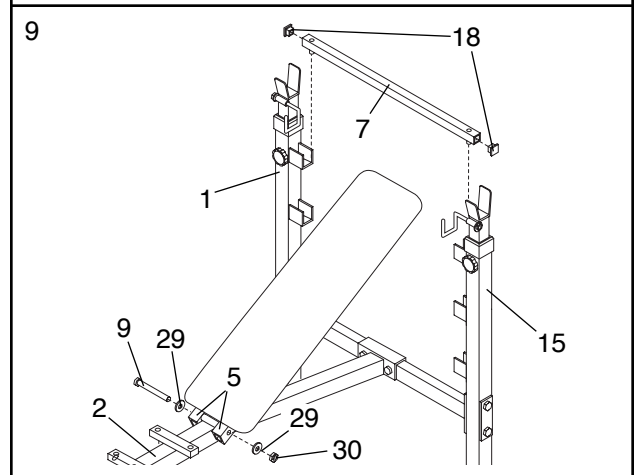

- Press a 1" Square Inner Cap (18) into each end of the seat support brackets on the Frame (2).

Attach the Seat (11) to the seat support brackets on the Frame (2) with four M8 x 40mm Bolts (27) and four M8 Washers (17).

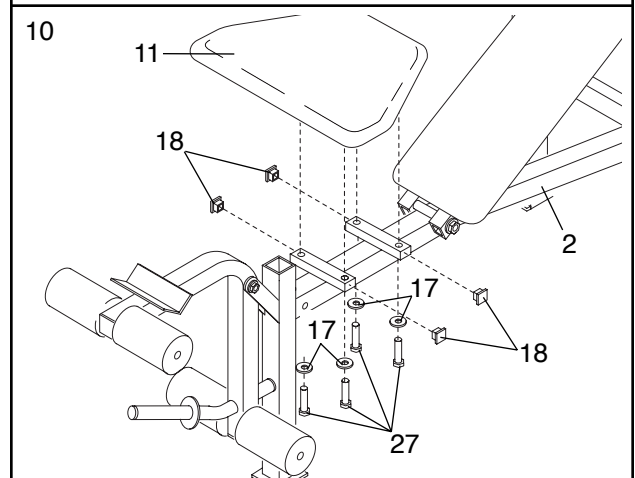

11. Attach the Curl Pad (12) to the Curl Upright (13) with two M6 x 16mm Screws (24).

Slide the Curl Upright (13) into the Front Leg (8). Align one of the adjustment holes in the Curl Upright with the adjustment hole in the Front Leg. Tighten the Small Threaded Knob (19) into the adjustment hole in the Front Leg.

Note: The Lat Tower (see below) can be attached in the same manner.

12. Locate the Cable (38) and note that it has a closed loop on one end and a ball on the other. Slide the closed loop through the slot in the Lat Tower (23) from the direction shown.

Place the Cable (38) in the groove of the Pulley (39) and attach the Pulley inside the slot in the Lat Tower (23) with the M10 x 52mm Bolt (35), two M10 Washers (29), two Pulley Spacers (40) and an M10 Nylon Locknut (30).

Press a 38mm Square Inner Cap (32) into the top of the Lat Tower (23).

13. Refer to the inset drawing. Press a Carriage Bushing (41) onto each end of the Weight Carriage (42). Press a 25.4mm Round Inner Cap (21) into each end of the weight tube on the Weight Carriage.

Slide the Weight Carriage (42) onto the Lat Tower (23). **Make sure the Weight Carriage is oriented as shown.**

Attach the closed loop on the Cable (38) to the bracket on the Weight Carriage (42) with a Cable Clip (37).

Note: The Lat Tower (23) can be mounted in the Front Leg (8) in the same way as the Curl Pad (see step 11).

14. **Make sure all parts are properly tightened before you use the weight bench. The use of all remaining parts will be explained in ADJUSTING THE WEIGHT BENCH starting on the next page.**

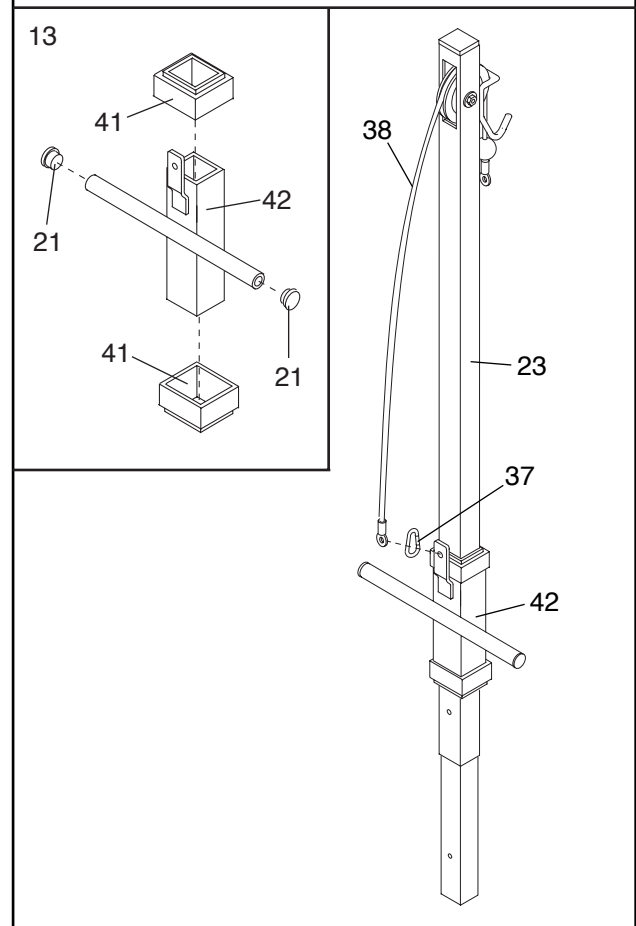
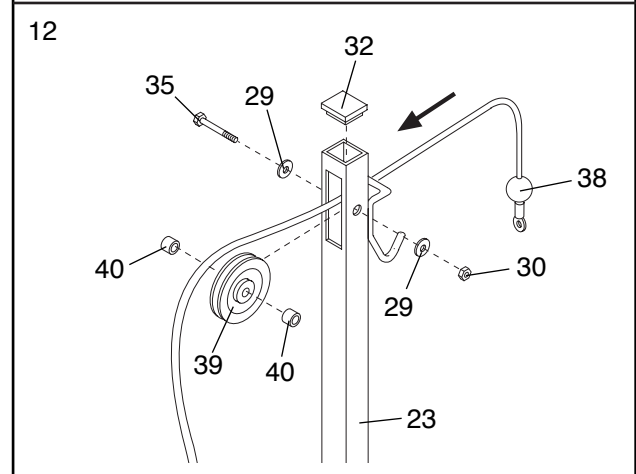
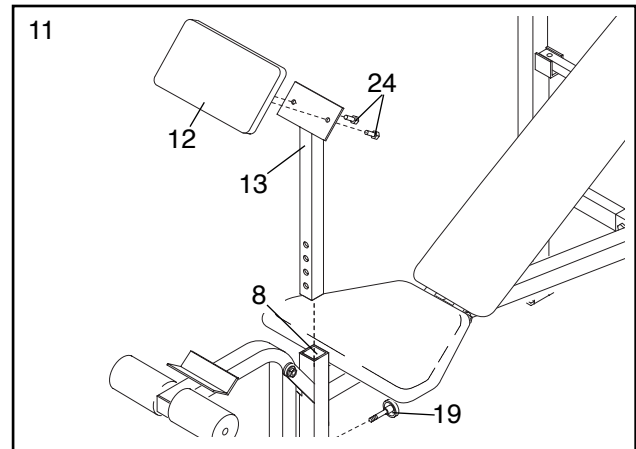

Using the Weight Bench

The weight bench is designed to be used with your own weight set (not included). The steps below explain how the weight bench can be adjusted. See EXERCISE GUIDELINES on page 12 for important exercise information and refer to the accompanying exercise poster to see the correct form for each exercise. Refer also to the exercise information accompanying your weight set (not included) for additional exercises.

Inspect and tighten all parts each time you use the weight bench. Replace any worn parts immediately. The weight bench can be cleaned with a damp cloth and a mild, non-abrasive detergent. Do not use solvents.

ADJUSTING THE BACKREST

The Backrest (6) can be used in a level position, two inclined positions, or a declined position. To use the Backrest in a level position, first lift the Backrest. Insert the Support Tube (7) into the lowest set of adjustment brackets on the Uprights (1, 15). Lay the Backrest Tubes (5) on the Support Tube.

To use the Backrest (6) in an inclined position, first lift the Backrest. Insert the Support Tube (7) into one of the two upper sets of adjustment brackets on the Uprights (1, 15). Lay the Backrest Tubes (5) on the Support Tube.

To use the Backrest (6) in a declined position, lift the Backrest and remove the Support Tube. Lay the Backrest Tubes (5) on the Crossbar (3).

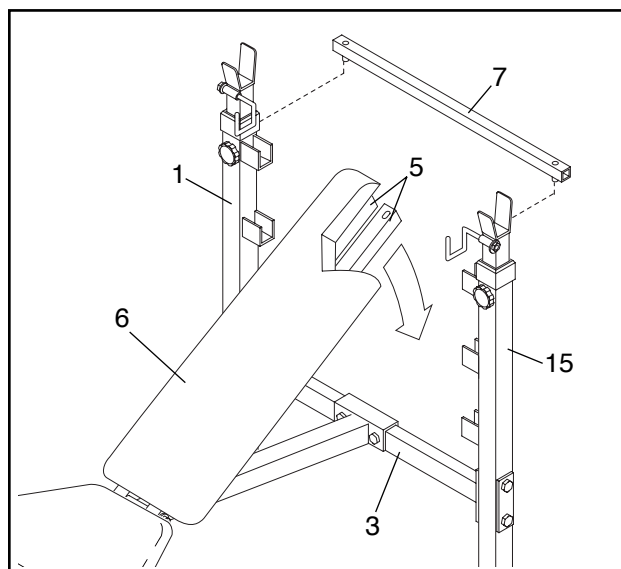

ADJUSTING THE WEIGHT RESTS

To adjust the Weight Rests (16), remove the Large Threaded Knobs (20) from the Uprights (1, 15). Move the Weight Rests to the desired height and replace the Large Threaded Knobs.

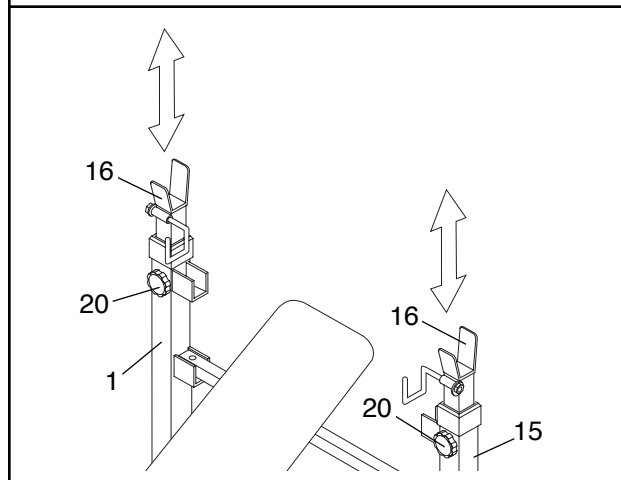

⚠ WARNING: Always set both Weight Rests (16) at the same height. The Large Threaded Knobs (20) must be inserted through both the Weight Rests and the Uprights and firmly tightened. Never tighten the Knobs into the Uprights and then set the Weight Rests in the Uprights on top of the Knobs.

ATTACHING WEIGHTS TO THE LEG LEVER

Note: Remove the curl upright or the lat tower before using the Leg lever (4) (see page 11). To use the Leg Lever, slide the desired weights (not included) onto the weight tube. Secure the weights with a Spring Clip (45, not shown).

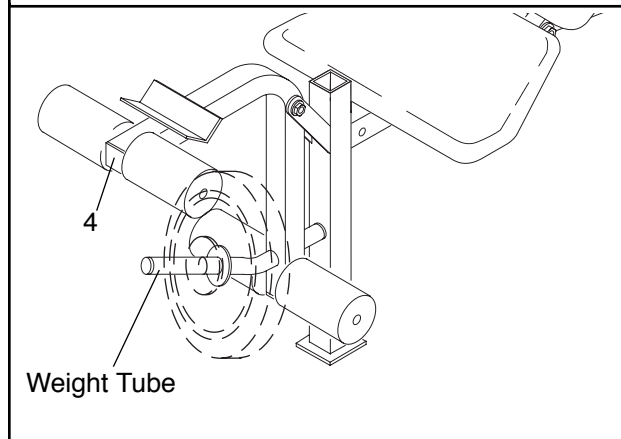

⚠ WARNING: Do not place more than 50 pounds on the Leg Lever (4) for normal use.

ATTACHING THE CURL UPRIGHT OR LAT TOWER

Slide the Curl Upright (13) or Lat Tower (23) into the Front Leg (8). Align one of the adjustment holes in the Curl Upright or Lat Tower with the adjustment hole in the Front Leg. Tighten the Small Threaded Knob (19) into the adjustment hole in the Front Leg.

ATTACHING WEIGHTS TO THE WEIGHT CARRIAGE

To use the Lat Tower (23), slide the desired amount of weight (not included) onto the weight tubes on the Weight Carriage (42). **Secure the weights with the Spring Clips (45).**

⚠ WARNING: Do not place more than 110 pounds on the Weight Carriage (42). Always place the same amount of weight on each side of the Weight Carriage.

When performing an exercise while sitting on the bench with your back to the lat tower, make sure that there is plenty of space between your back and the Weight Carriage (42). Always lower the Weight Carriage in a controlled manner; never let the Weight Carriage drop.

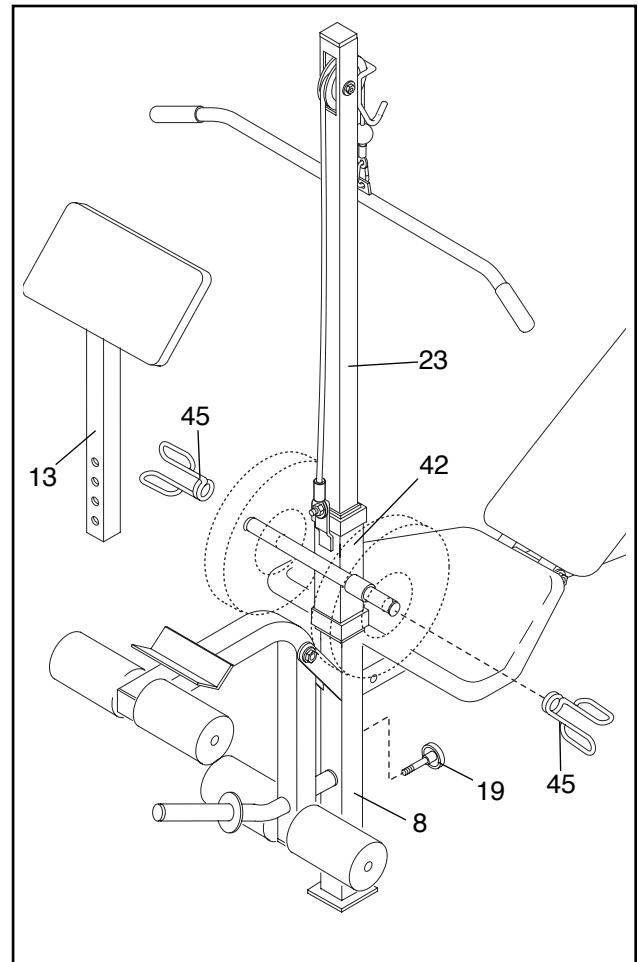

ATTACHING THE LAT BAR TO THE LAT TOWER

To use the Lat Tower (23), attach the Lat Bar (48) to the Cable (38) with a Cable Clip (37).

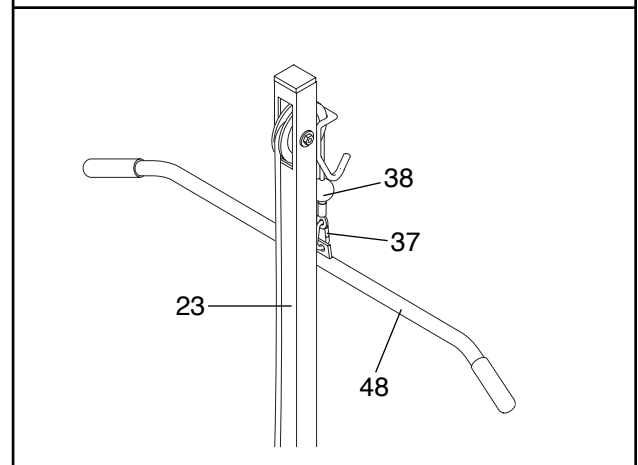

USING THE BARBELL HOOKS

To change weights while your barbell (not included) is on the Weight Rests (16), secure the barbell with the Barbell Hooks (46, 47). To do this, flip the Barbell Hooks over the barbell.

This will reduce the possibility of the barbell tipping while you are changing weights.

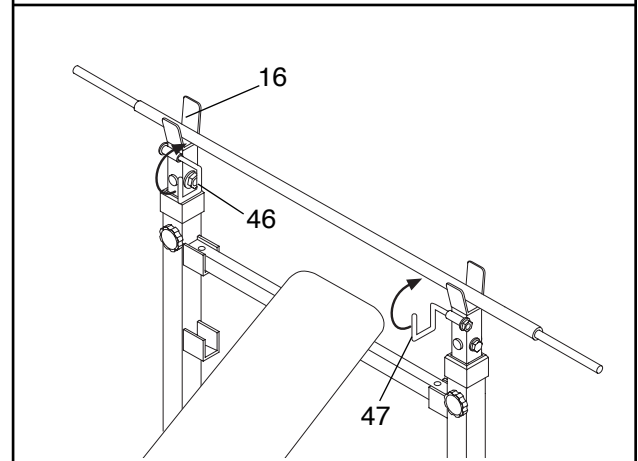

Exercise Guidelines

THE FOUR BASIC TYPES OF WORKOUTS

• Muscle Building

In order to increase the size and strength of your muscles, you must push your muscles to a high percentage of their capacity. You must also progressively increase the intensity of your exercise so that your muscles continue to adapt and grow. Each exercise can be tailored to the proper intensity level by changing the amount of weight used, or the number of repetitions or sets performed. (A "repetition" is one complete cycle of an exercise, such as one sit-up. A "set" is a series of repetitions performed consecutively.)

The proper amount of weight for each exercise depends upon the individual user. It is up to you to gauge your limits. Select the amount of weight that you think is right for you. Begin with 3 sets of 8 repetitions for each exercise that you perform. Rest for 3 minutes after each set. When you can complete 3 sets of 12 repetitions without difficulty, increase the amount of weight.

• Toning

To tone your muscles, you must push your muscles to a moderate percentage of their capacity. Select a moderate amount of weight and increase the number of repetitions in each set. Complete as many sets of 15 to 20 repetitions as possible without discomfort. Rest for 1 minute after each set. Work your muscles by completing more sets rather than by using high amounts of weight.

• Weight Loss

To lose weight, use a low amount of weight and increase the number of repetitions in each set. Exercise for 20 to 30 minutes, resting for a maximum of 30 seconds between sets.

• Cross Training

In the pursuit of a complete and well-balanced fitness program, many have found that cross training is the answer. We recommend that on Monday, Wednesday and Friday, you plan weight training workouts. On Tuesday and Thursday, plan 20 to 30 minutes of aerobic exercise, such as cycling, running or swimming. Rest from both weight training and aerobic exercise for at least one full day each week to give your body time to regenerate. By combining weight training with aerobic exercise, you can reshape and strengthen your body, plus develop a stronger heart and lungs.

PERSONALIZING YOUR EXERCISE PROGRAM

We have not specified an exact length of time for each workout, or a specific number of repetitions or sets for each exercise. It is very important to avoid overdoing it during the first few months of your exercise program, and to progress at your own pace. If you experience pain or dizziness at any time while exercising, stop immediately and begin to cool down. Find out what is wrong before continuing. Remember that adequate rest and a proper diet are also important.

WARMING UP

Begin each workout with 5 to 10 minutes of light stretching and exercise to warm up. Warming up prepares your body for exercise by increasing circulation, raising your body temperature and delivering more oxygen to your muscles.

WORKING OUT

Each workout should include 6 to 10 different exercises. Select exercises for every major muscle group, with emphasis on the areas that you want to develop the most. To give balance and variety to your workouts, vary the exercises from workout to workout.

Schedule your workouts for the time of day when your energy level is the highest. Each workout should be followed by at least one day of rest. Once you find the schedule that is right for you, stick with it.

EXERCISE FORM

In order to obtain the greatest benefits from exercising, it is essential to maintain proper form.

Maintaining proper form means moving through the full range of motion for each exercise, and moving only the appropriate parts of the body. Exercising in an uncontrolled manner will leave you feeling exhausted. On the exercise poster accompanying this manual, you will find photographs showing the correct form for several exercises. A description of each exercise is also provided, along with a list of the muscles affected. Refer to the muscle chart on the next page to find the locations of the muscles.

The repetitions in each set should be performed smoothly and without pausing. The exertion stage of each repetition should last about half as long as the return stage. Proper breathing is important. Exhale during the exertion stage of each repetition and inhale

during the return stroke; never hold your breath. Rest for 3 minutes after each set if you are doing a muscle building workout, 1 minute after each set if you are doing a toning workout, and 30 seconds after each set if you are doing a weight loss workout. Plan to spend the first couple of weeks familiarizing yourself with the equipment and learning the proper form for each exercise.

COOLING DOWN

End each workout with 5 to 10 minutes of stretching. Include stretches for both your arms and legs. Move slowly as you stretch—do not bounce. Ease into each stretch gradually and go only as far as you can with-

out strain. Stretching at the end of each workout is very effective for increasing flexibility.

STAYING MOTIVATED

For motivation, keep a record of each workout. List the date, exercises performed, weight and numbers of sets and repetitions completed. Record your weight and key body measurements at the end of every month.

Remember, the key to achieving the greatest results is to make exercise a regular and enjoyable part of your everyday life.

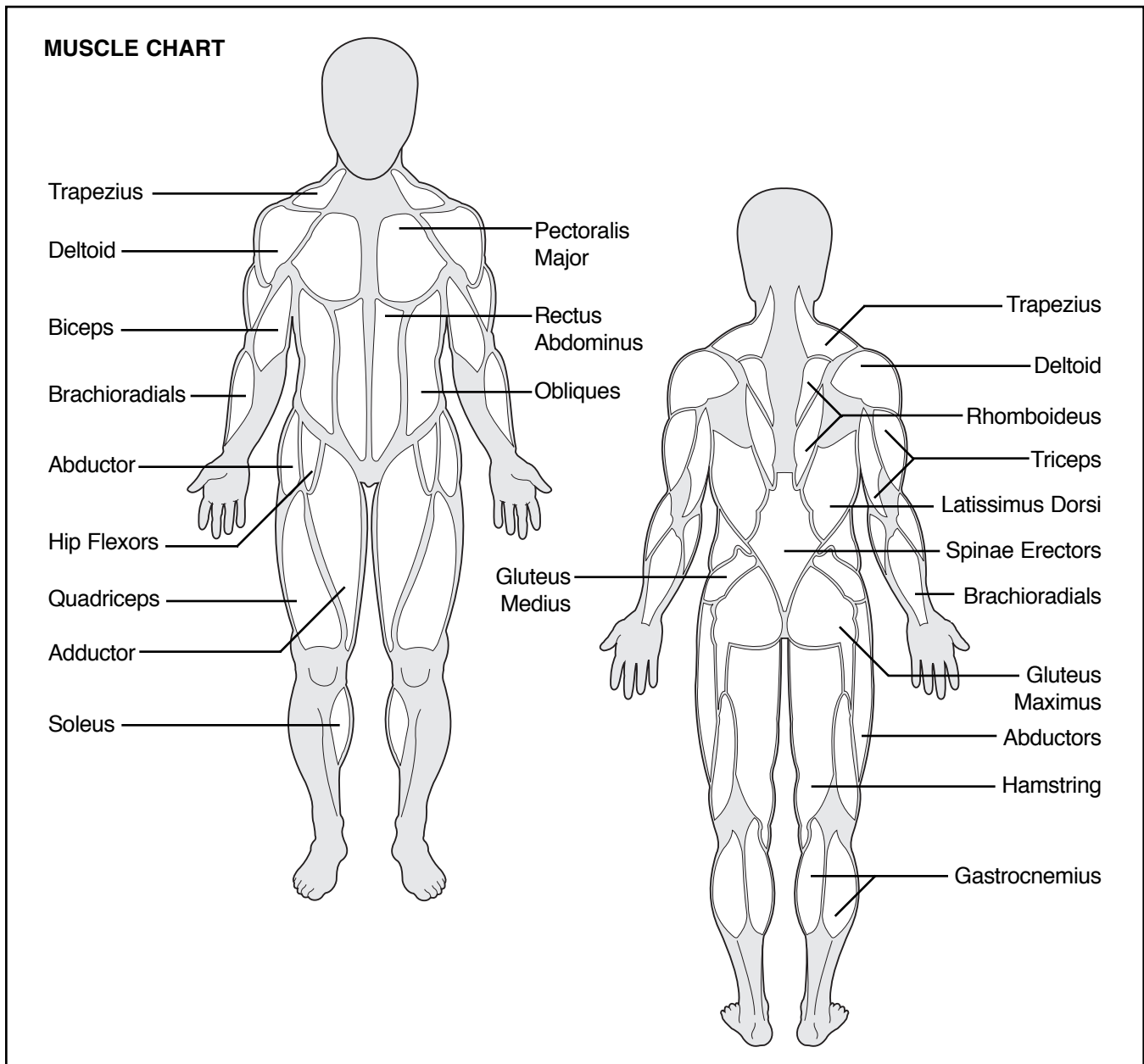

Key No.	Qty.	Description	Key No.	Qty.	Description
1	1	Right Upright	27	8	M8 x 40mm Bolt
2	1	Frame	28	1	45mm x 45mm Square Inner Cap
3	1	Crossbar	29	6	M10 Washer
4	1	Leg Lever	30	7	M10 Nylon Locknut
5	2	Backrest Tube	31	2	50mm Square Bushing
6	1	Backrest	32	3	38mm Square Inner Cap
7	1	Support Tube	33	4	19mm Round Inner Cap
8	1	Front Leg	34	6	M8 Nylon Locknut
9	1	M10 x 130mm Bolt	35	1	M10 x 52mm Bolt
10	2	Pad Tube	36	2	50mm x 50mm Square Inner Cap
11	1	Seat	37	2	Cable Clip
12	1	Curl Pad	38	1	Cable
13	1	Curl Upright	39	1	Pulley
14	2	Support Plate	40	2	Pulley Spacer
15	1	Left Upright	41	2	Carriage Bushing
16	2	Weight Rest	42	1	Weight Carriage
17	14	M8 Washer	43	2	Grip
18	8	1" Square Inner Cap	44	2	M8 x 50mm Bolt
19	1	Small Threaded Knob	45	2	Spring Clip
20	2	Large Threaded Knob	46	1	Right Barbell Hook
21	4	25.4mm Round Inner Cap	47	1	Left Barbell Hook
22	4	Foam Pad	48	1	Lat Bar
23	1	Lat Tower	#	1	User's Manual
24	2	M6 x 16mm Screw	#	1	Exercise Poster
25	2	M8 x 55mm Bolt			
26	5	M10 x 70mm Bolt			

"#" Indicates a non-illustrated part. Specifications are subject to change without notice. See the back cover of this manual for information about ordering replacement parts.

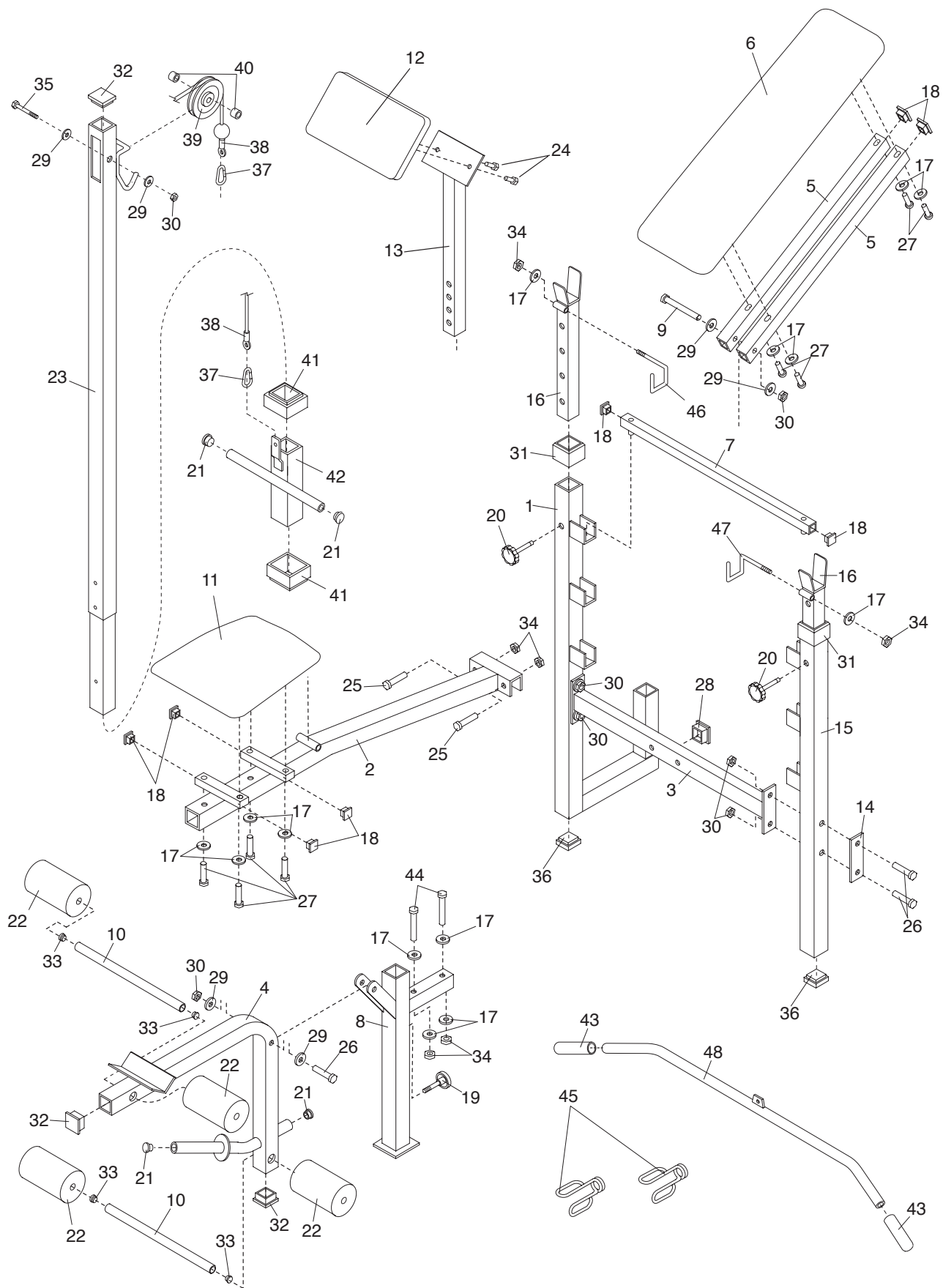

Ordering Replacement Parts

To order replacement parts, simply call our Customer Service Department toll-free at 1-800-999-3756, Monday through Friday, 6 a.m. until 6 p.m. Mountain Time (excluding holidays). To help us assist you, please be prepared to give the following information when calling:

- The MODEL NUMBER of the product (WEBE06691)
- The NAME of the product (WEIDER® 144 weight bench)
- The SERIAL NUMBER of the product (see the front cover of this manual)
- The KEY NUMBER and DESCRIPTION of the desired part(s) (see the PART LIST and the EXPLODED DRAWING at the center of this manual).

Limited Warranty

ICON Health & Fitness, Inc. (ICON), warrants this product to be free from defects in workmanship and material, under normal use and service conditions, for a period of ninety (90) days from the date of purchase. This warranty extends only to the original purchaser. ICON's obligation under this warranty is limited to replacing or repairing, at ICON's option, the product at one of its authorized service centers. All products for which warranty claim is made must be received by ICON at one of its authorized service centers with all freight and other transportation charges prepaid, accompanied by sufficient proof of purchase. All returns must be pre-authorized by ICON. This warranty does not extend to any product or damage to a product caused by or attributable to freight damage, abuse, misuse, improper or abnormal usage or repairs not provided by an ICON authorized service center, products used for commercial or rental purposes, or products used as store display models. No other warranty beyond that specifically set forth above is authorized by ICON.

ICON is not responsible or liable for indirect, special or consequential damages arising out of or in connection with the use or performance of the product or damages with respect to any economic loss, loss of property, loss of revenues or profits, loss of enjoyment or use, costs of removal, installation or other consequential damages of whatsoever nature. Some states do not allow the exclusion or limitation of incidental or consequential damages. Accordingly, the above limitation may not apply to you.

The warranty extended hereunder is in lieu of any and all other warranties and any implied warranties of merchantability or fitness for a particular purpose is limited in its scope and duration to the terms set forth herein. Some states do not allow limitations on how long an implied warranty lasts. Accordingly, the above limitation may not apply to you.

This warranty gives you specific legal rights. You may also have other rights which vary from state to state.

ICON HEALTH & FITNESS, INC., 1500 S. 1000 W., LOGAN, UT 84321-9813

Free Manuals Download Website

<http://myh66.com>

<http://usermanuals.us>

<http://www.somanuals.com>

<http://www.4manuals.cc>

<http://www.manual-lib.com>

<http://www.404manual.com>

<http://www.luxmanual.com>

<http://aubethermostatmanual.com>

Golf course search by state

<http://golfingnear.com>

Email search by domain

<http://emailbydomain.com>

Auto manuals search

<http://auto.somanuals.com>

TV manuals search

<http://tv.somanuals.com>