



# WEIDER PRO

3650

Model No. WESY39523

Serial No. \_\_\_\_\_

Write the serial number in the space above for future reference.

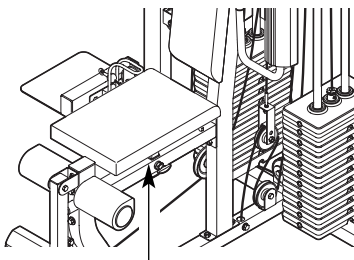

Serial Number Decal (Under Seat)

## QUESTIONS?

As a manufacturer, we are committed to providing complete customer satisfaction. If you have questions, or if parts are missing, we will guarantee complete satisfaction through assistance from our factory.

**TO AVOID DELAYS, PLEASE CALL DIRECT TO OUR TOLL-FREE CUSTOMER HOT LINE.** The technicians on our customer hot line will provide immediate assistance, free of charge.

**CUSTOMER HOT LINE:**

**1-800-999-3756**

Mon.-Fri., 6 a.m.-6 p.m. MST

## CAUTION

Read all precautions and instructions in this manual before using this equipment. Save this manual for future reference.

## USER'S MANUAL

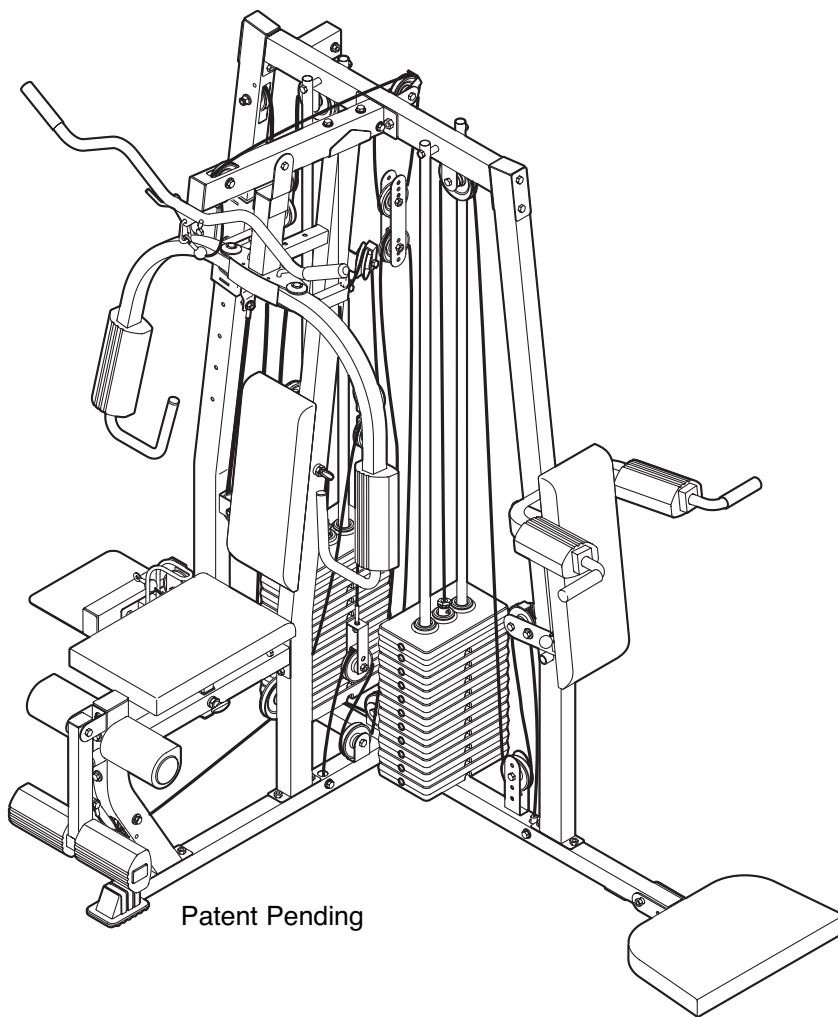

Visit our website at

[www.weiderfitness.com](http://www.weiderfitness.com)

new products, prizes,  
fitness tips, and much more!



# WEIDER PRO

3650

---

## TABLE OF CONTENTS

IMPORTANT PRECAUTIONS .....	.3
BEFORE YOU BEGIN .....	.4
ASSEMBLY .....	.5
ADJUSTMENTS .....	.22
WEIGHT RESISTANCE CHART .....	.24
TROUBLESHOOTING .....	.25
CABLE DIAGRAMS .....	.26
ORDERING REPLACEMENT PARTS .....	.Back Cover
LIMITED WARRANTY .....	.Back Cover

Note: A PART IDENTIFICATION CHART and a PART LIST/EXPLODED DRAWING are attached in the center of this manual. Remove the PART IDENTIFICATION CHART and the PART LIST/EXPLODED DRAWING before beginning assembly.

# IMPORTANT PRECAUTIONS

**⚠️ WARNING:** To reduce the risk of serious injury, read the following important precautions before using the weight system.

1. Read all instructions in this manual and in the accompanying literature before using the weight system.
2. It is the responsibility of the owner to ensure that all users of the weight system are adequately informed of all precautions.
3. The weight system is intended for home use only. Do not use the weight system in any commercial, rental, or institutional setting.
4. Use the weight system only on a level surface. Cover the floor beneath the weight system to protect the floor.
5. Make sure that all parts are properly tightened each time the weight system is used. Replace any worn parts immediately.
6. Keep children under 12 and pets away from the weight system at all times.
7. Keep hands and feet away from moving parts.
8. Always wear athletic shoes for foot protection.
9. The weight system is designed to support a maximum user weight of 300 pounds.
10. The weight system should not be used by more than one person at a time.
11. Always stand on the foot plate when performing an exercise that could cause the weight system to tip.
12. Never release the butterfly arms, leg lever, squat arm, lat bar, row bar, or handle while weights are raised; the weights will fall with great force.
13. Always disconnect the lat bar from the weight system when performing an exercise that does not use the lat bar.
14. Make sure that the cables remain on the pulleys at all times. If the cables bind while you are exercising, stop immediately and make sure that the cables are on all of the pulleys.
15. If you feel pain or dizziness at any time while exercising, stop immediately and begin cooling down.
16. The decals shown below have been placed on the weight system in the locations shown on page 4. If a decal is missing or illegible, call our toll-free Customer Hot Line at 1-800-999-3756 and order a free replacement decal. Apply the decal in the location shown.

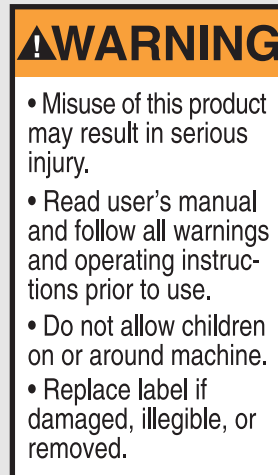

Decal 1



Decal 2

**⚠️ WARNING:** Before beginning this or any exercise program, consult your physician. This is especially important for persons over the age of 35 or persons with pre-existing health problems. Read all instructions before using. ICON assumes no responsibility for personal injury or property damage sustained by or through the use of this product.

# BEFORE YOU BEGIN

Thank you for selecting the versatile WEIDER® PRO 3650 weight system. The WEIDER® PRO 3650 weight system offers an impressive array of weight stations designed to develop every major muscle group of the body. Whether your goal is to tone your body, build dramatic muscle size and strength, or improve your cardiovascular system, the PRO 3650 weight system will help you to achieve the specific results you want.

Department toll-free at 1-800-999-3756, Monday through Friday, 6 a.m. until 6 p.m. Mountain Time (excluding holidays). To help us assist you, please note the product model number and serial number before calling. The model number is WESY39523. The serial number can be found on a decal attached to the weight system (see the front cover of this manual for the location of the decal).

**For your benefit, read this manual carefully before using the weight system.** If you have additional questions, please call our Customer Service

Before reading further, please review the drawing below and familiarize yourself with the parts that are labeled.

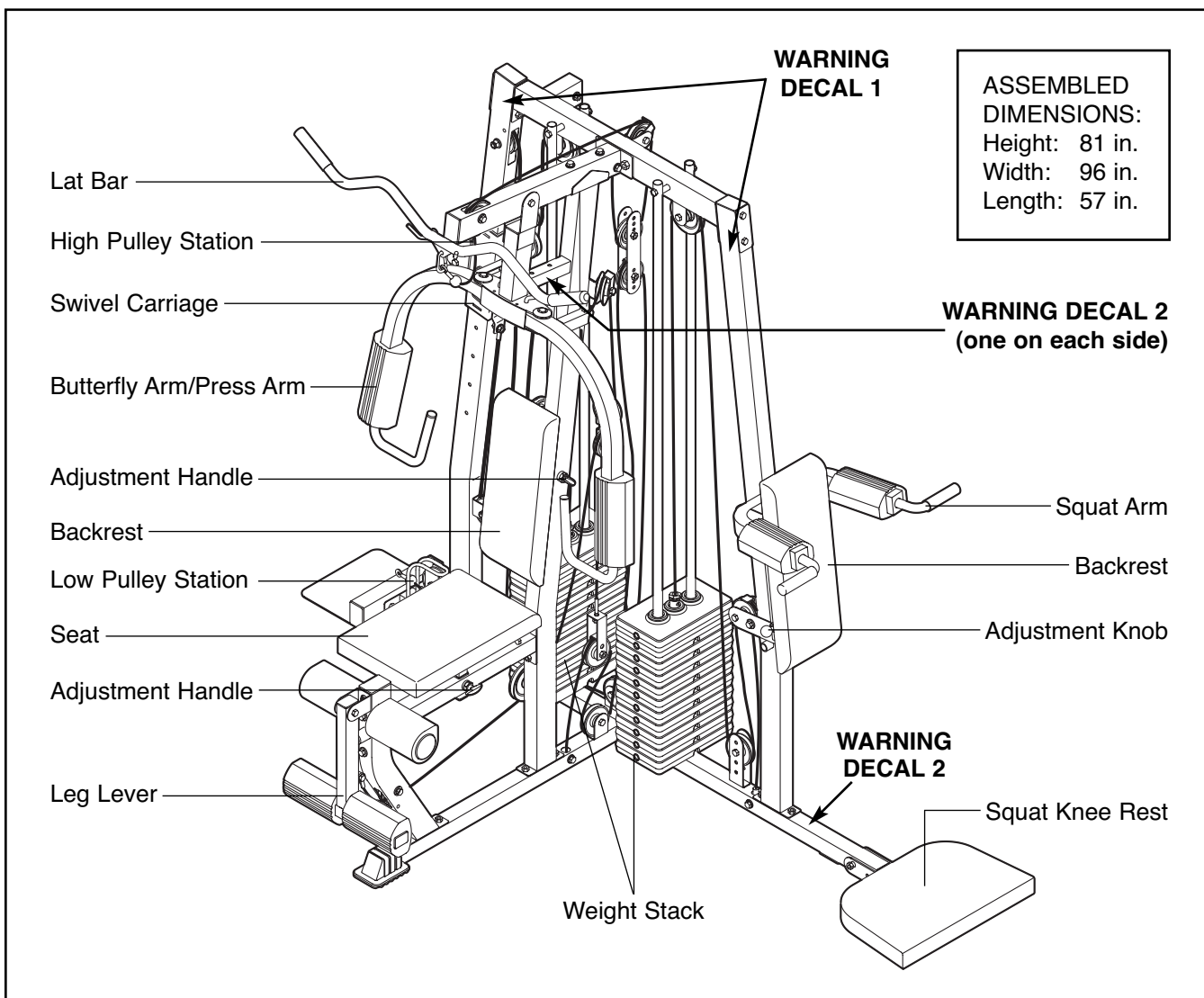

# ASSEMBLY

## Make Assembly Easier

Everything in this manual is designed to ensure that the weight system can be assembled successfully by anyone.

**Before beginning assembly, make sure to read the information on this page. This brief introduction will save you much more time than it takes to read it.**

## Assembly Requires Two Persons

For your convenience and safety, assemble the weight system with the help of another person.

## Set Aside Enough Time

Due to the many features of the weight system, the assembly process will require several hours. By setting aside plenty of time and by deciding to make the task enjoyable, assembly will go smoothly.

## Select a Location for the Weight System



Because of its weight and size, the weight system should be assembled in the location where it will be used. Make sure that there is enough room to walk around the weight system as you assemble it.

## How to Unpack the Box

To make assembly easier, we have divided the assembly process into four stages. The small hardware needed for each stage is packaged in separate bags. **Important: Wait until you begin each stage to open the parts bag(s) for that stage.**

Place all parts of the weight system in a cleared area and remove the packing materials. Do not dispose of the packing materials until assembly is completed.

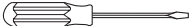
## Make sure that you have the following tools:

- Two adjustable wrenches 
  - One standard screwdriver 
  - One phillips screwdriver 
  - One rubber mallet 
- You will also need grease or petroleum jelly, a small amount of soapy water, and masking tape.

Note: Assembly will be more convenient if you have a socket set, a set of open-end or closed-end wrenches, or a set of ratchet wrenches.

## How to Identify Parts

To help you identify the small parts used in assembly, a **PART IDENTIFICATION CHART** is included in the center of this manual. Lay the chart on the floor and use it to easily identify parts during each assembly step. **Note: Some small parts may have been pre-attached. If a part is not in the parts bag, check to see if it has been pre-attached.**

## How to Orient Parts

As you assemble the weight system, make sure that all parts are oriented exactly as shown in the drawings.

## Tightening Parts

Tighten all parts as you assemble them, unless instructed to do otherwise.

## Questions?

If you have questions after reading the assembly instructions, please call our Customer Service Department toll-free at **1-800-999-3756**, Monday through Friday, 6 a.m. until 6 p.m. Mountain Time.

## The Four Stages of the Assembly Process

**Frame Assembly**—You will begin by assembling the base and the uprights that form the skeleton of the weight system.

**Arm Assembly**—During this stage, you will assemble the arms and the leg lever.

**Cable Assembly**—During this stage, you will attach the cables and pulleys that connect the weight stations to the weight stacks.

**Seat Assembly**—During the final stage, you will assemble the seat and the backrests.

## FRAME ASSEMBLY

1. **Make sure that you understand all of the information on page 5 before you begin assembling the weight system.**

Locate and open the parts bags labeled “FRAME ASSEMBLY 1” and “FRAME ASSEMBLY 2.”

See the inset drawing. Attach the Base Cap (24) to the Short Base (2) with two M4 x 20mm Self-tapping Screws (14) and two M4 Washers (120).

Press a 50mm Square Inner Cap (105) into the open end of the Long Base (101).

Insert eight M10 x 65mm Carriage Bolts (110) up through the Long Base (101) and the Short Base (2) as shown. **Note: It may be helpful to place tape over the heads of the Carriage Bolts to hold them in place.**

Attach the Short Base (2) to the Long Base (101) with two M10 x 70mm Bolts (85), the Long Frame Plate (71), and two M10 Nylon Locknuts (87).

2. Press two 50mm x 75mm Inner Caps (58) into the Foot Plate (53). Attach the Foot Plate to the Long Base (101) with two M10 x 65mm Carriage Bolts (110) and two M10 Nylon Locknuts (87).

3. Attach the tether on the Long Pin w/Tether (112) to the Long Base (101) with an M4 x 20mm Self-tapping Screw (14).

Attach the four Knee Rest Bumpers (108) to the Squat Knee Rest (41) with four M4 x 20mm Self-tapping Screws (14). Attach the Squat Knee Rest to the Long Base (101) with an M10 x 85mm Bolt (96) and an M10 Nylon Locknut (87). **Do not overtighten the Locknut; the Squat Knee Rest must be able to pivot.**

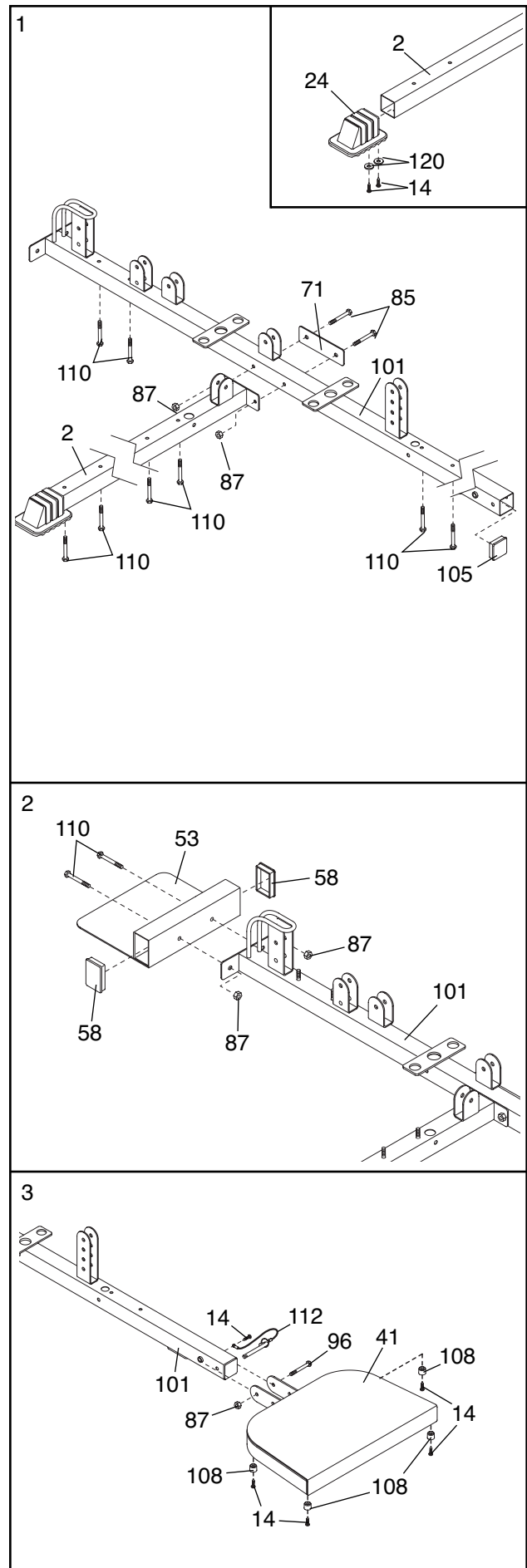

4. Press a 38mm Square Inner Cap (67) into the Upright Extension (12).

Attach the Upright Extension (12) to the Butterfly Upright (3) with two M10 x 95mm Bolts (92), two M10 Washers (91), and two M10 Nylon Locknuts (87). **Make sure the warning decals on each side of the Extension are right-side up.**

Slide the Butterfly Upright (3) onto the two indicated M10 x 65mm Carriage Bolts (110) in the Short Base (2). Finger tighten an M10 Nylon Locknut (87) onto each Carriage Bolt. **Do not tighten the Locknuts yet.**

Tighten an Adjustment Handle (65) into the Butterfly Upright (3).

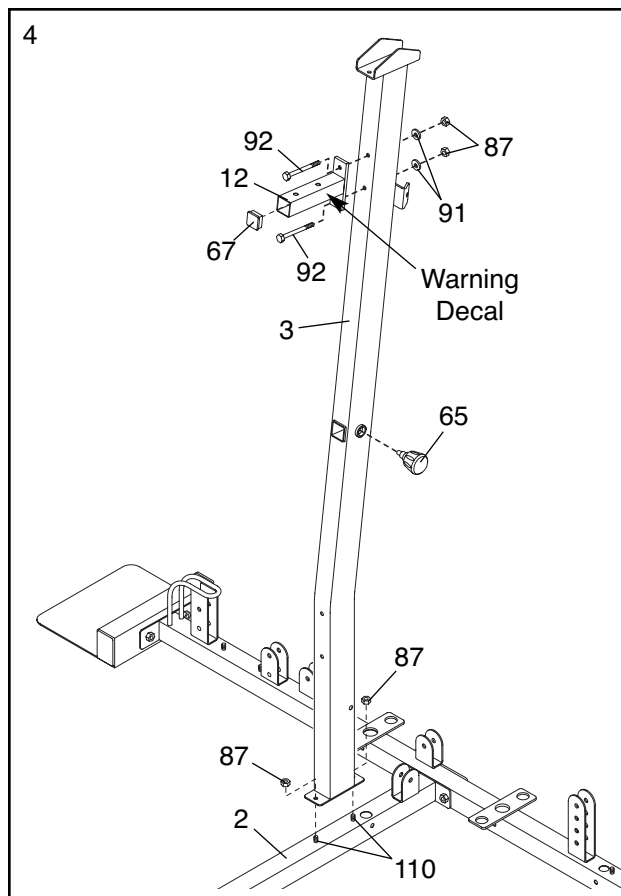

5. Press a 50mm x 75mm Inner Cap (58) into the top of the Seat Upright (9). Attach the Leg Lever Bumper (77) to the Seat Upright with an M4 x 20mm Self-tapping Screw (14) and an M4 Washer (120).

Slide the Seat Upright (9) onto the two indicated M10 x 65mm Carriage Bolts (110) in the Short Base (2). Finger tighten an M10 Nylon Locknut (87) onto each Carriage Bolt. **Do not tighten the Locknuts yet.**

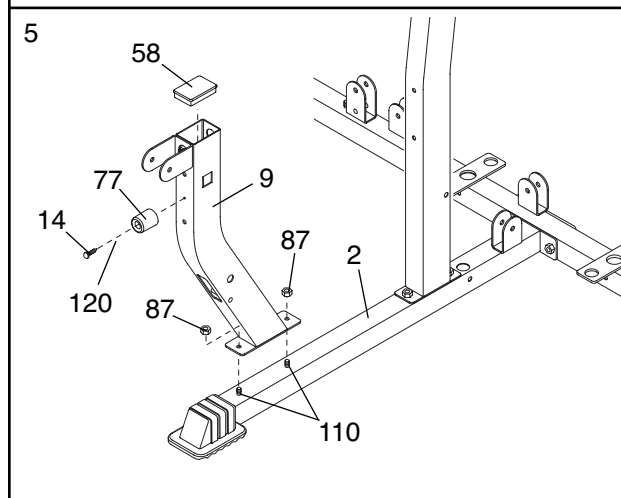

6. Hold the Seat Frame (8) between the Seat Upright (9) and the Butterfly Upright (3). Attach the Seat Frame to the Seat Upright with two M10 x 95mm Bolts (92), two M10 Washers (91), and two M10 Nylon Locknuts (87). **Do not tighten the Locknuts yet.**

Attach the Seat Frame (8) to the Butterfly Upright (3) with two M10 x 95mm Bolts (92), two M10 Washers (91), and two M10 Nylon Locknuts (87). **Do not tighten the Locknuts yet.**

Tighten an Adjustment Handle (65) into the Seat Frame (8).

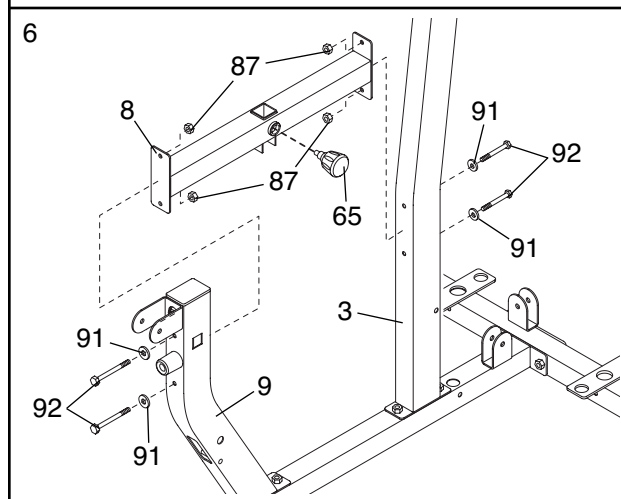



7. Press a 50mm x 75mm Inner Cap (58) into the top of the Squat Upright (4). Press two 25mm Round Outer Cap (121) onto the Upright. Slide the Squat Upright onto the two indicated M10 x 65mm Carriage Bolts (110) in the Long Base (101). Finger tighten an M10 Nylon Locknut (87) onto each Carriage Bolt. **Do not tighten the Locknuts yet.**

Press a 50mm x 75mm Inner Cap (58) into the top of the Swivel Upright (5). Slide the Swivel Upright onto the two indicated M10 x 65mm Carriage Bolts (110) in the Long Base (101). Finger tighten an M10 Nylon Locknut (87) onto each Carriage Bolt. **Do not tighten the Locknuts yet.**

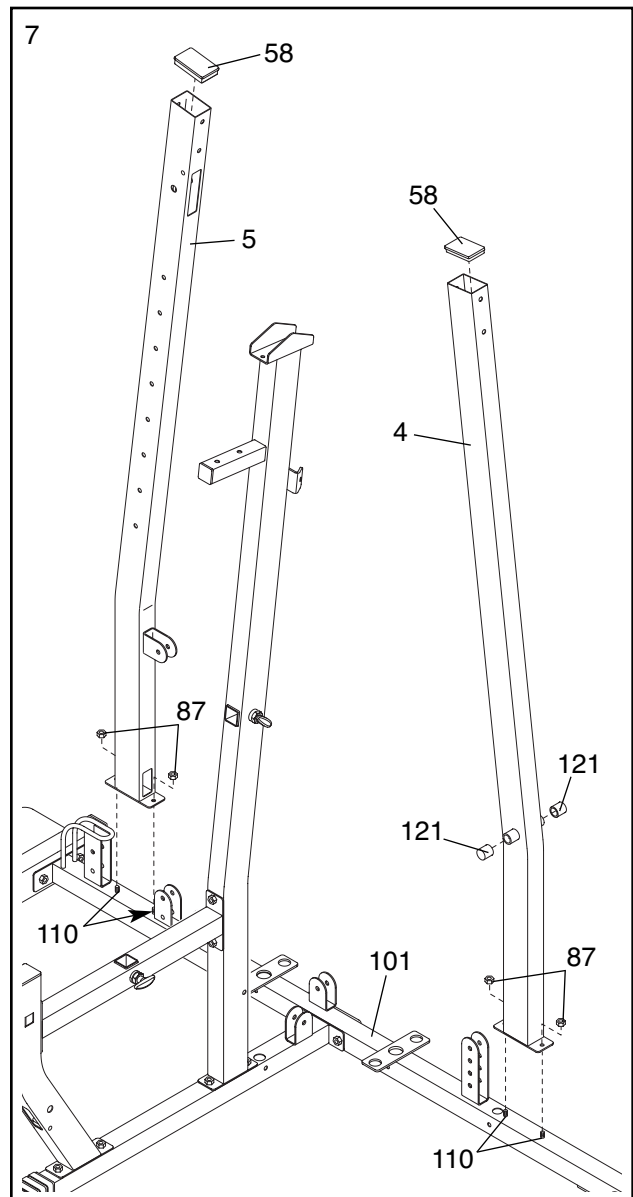

8. Press two Swivel Bushings (66) into the Swivel Carriage (46).

Tighten an Adjustment Handle (65) into the Swivel Carriage (46). Orient the Swivel Carriage as shown. Slide the Carriage onto the Swivel Upright (5) and engage the Adjustment Handle into an adjustment hole in the Swivel Upright.

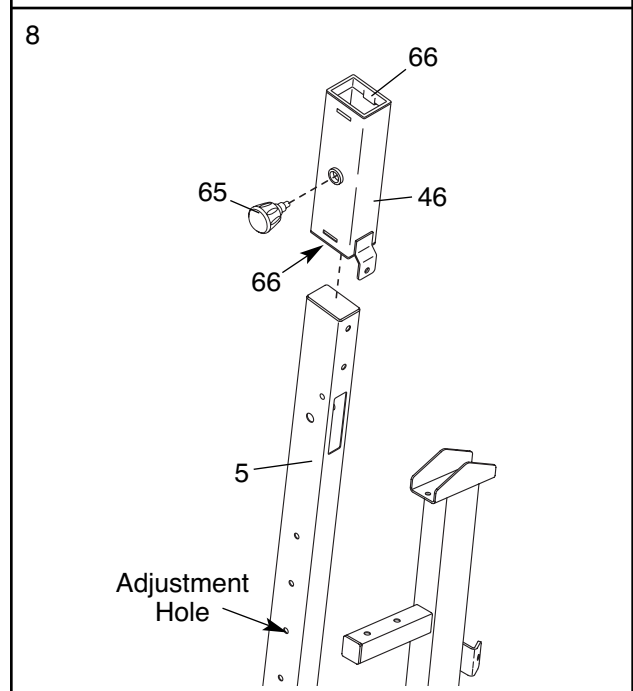



9. Attach a Roller (39) between the indicated set of holes in the Squat Slider (38) with an M8 x 85mm Bolt (94) and an M8 Nylon Locknut (34). **Do not overtighten the Locknut; the Roller must be able to roll easily.**

**Assemble the other three Rollers (39) to the Squat Slider (38) in the same manner.**

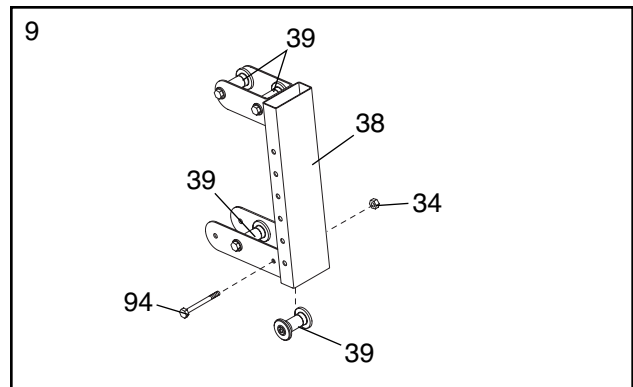

10. Orient the Squat Slider (38) as shown, and slide it down onto the Squat Upright (4).

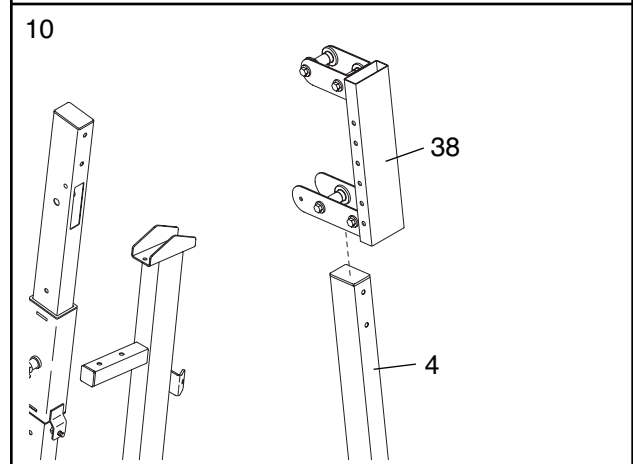

11. Insert the ends of two Weight Guides (42) without holes into the indicated bracket on the Long Base (101). Slide two Weight Bumpers (49) onto the Weight Guides. Next, slide ten Weights (44) onto the Weight Guides. **Make sure that the weights are turned so the grooved sides of the weights are facing downward.**

Press a Weight Tube Bumper (48) into the lower end of a Weight Tube (43). Insert the Weight Tube into the centers of the Weights (44). **Make sure that the Weight Tube is turned as shown.**

Lubricate the two outer holes in a Top Weight (45). Slide the Top Weight onto the Weight Guides (42). **Make sure that the Top Weight is turned so the grooved side is facing downward.**

Apply a number "10" decal to the Top Weight (45) in the location shown. Apply decals with the numbers 20 through 110 to the ten Weights (44).

**Assemble the other weight stack in the same way.**

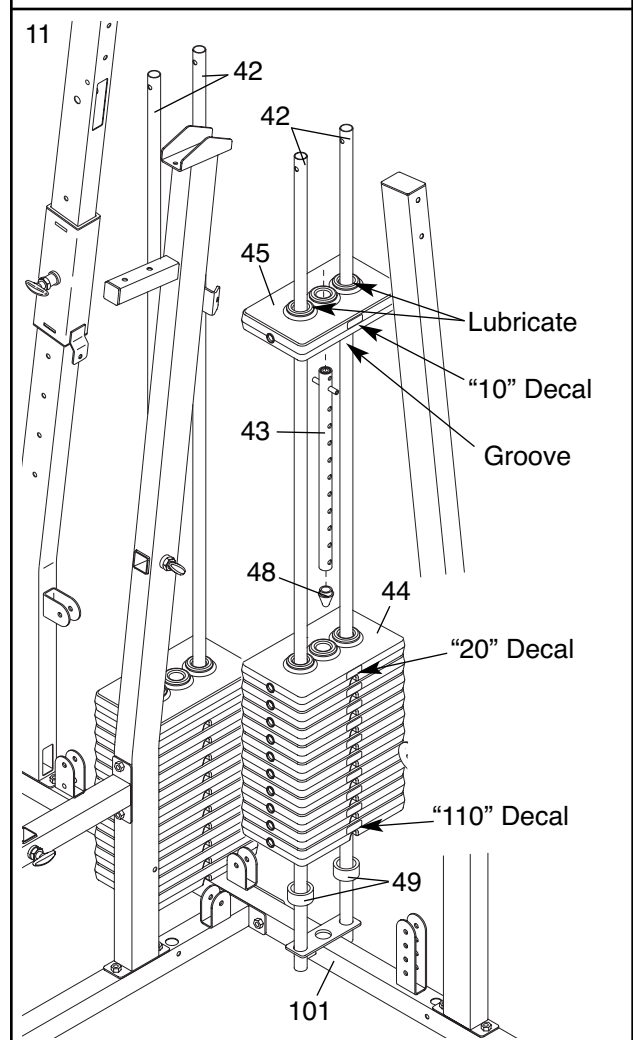

12. Attach the Top Frame (6) between the Squat Upright (4) and the Swivel Upright (5) with four M10 x 95mm Bolts (92), the two Short Frame Plates (52), and two M10 Nylon Locknuts (87) as shown. **Do not tighten the Bolts and Locknuts yet.**

Attach the four Weight Guides (42) to the Top Frame (6) with two M10 x 165mm Bolts (30) and two M10 Nylon Locknuts (87).

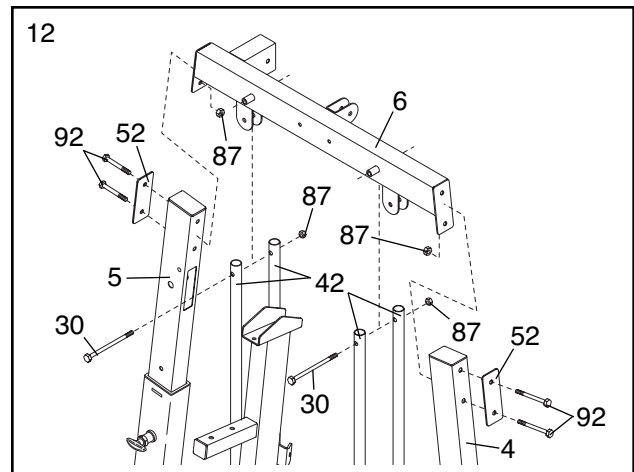

13. Press two 50mm x 75mm Inner Caps (58) into the Top Frame (6) and the Butterfly Top Frame (7).

Attach the Butterfly Top Frame (7) to the Top Frame (6) with two M10 x 70mm Bolts (85), two M10 Washers (91), and two M10 Nylon Locknuts (87). **Do not tighten the Locknuts yet.**

Attach the Butterfly Top Frame (7) to the Butterfly Upright (3) with two M10 x 95mm Bolts (92), two M10 Washers (91), and two M10 Nylon Locknuts (87).

**Tighten all of the M10 Nylon Locknuts (87) used in steps 4–13.**

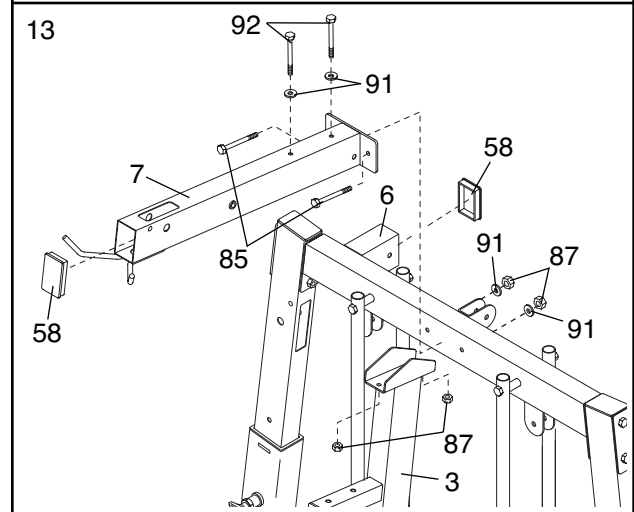

## ARM ASSEMBLY

14. Open the parts bag labeled “ARM ASSEMBLY.”

Press three 40mm x 50mm Inner Caps (21) into the Leg Lever (10).

Lubricate an M10 x 65mm Bolt (18) with grease. Turn the Leg Lever (10) so that the welded tab is on the indicated side, and attach the Leg Lever to the Seat Upright (9) with the Bolt and an M10 Nylon Locknut (87). **Do not overtighten the Locknut; the Leg Lever must be able to pivot easily.**

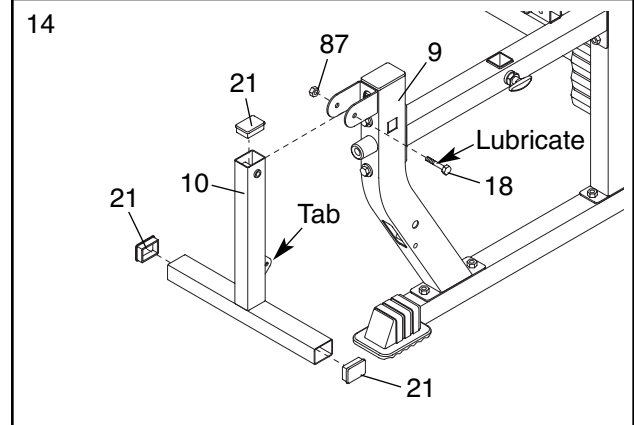

15. Press a 50mm x 70mm Inner Cap (95) into the Butterfly Frame (47). Attach the tethers on the two “L”-pins w/Tether (60) to the Butterfly Frame with an M4 x 20mm Self-tapping Screw (14).

Lubricate an M10 x 80mm Bolt (107) with grease. Attach the Butterfly Frame (47) to the Butterfly Top Frame (7) with the Bolt and an M10 Nylon Locknut (87). **Do not overtighten the Nylon Locknut; the Butterfly Frame must be able to pivot easily.**

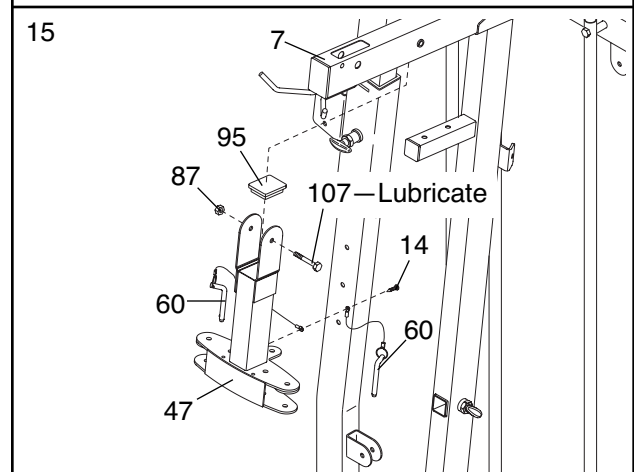

16. Press a 40mm x 50mm Inner Cap (21) into the Right Butterfly Arm (26). Wet the lower end of the Arm and a Long Pad (54) with soapy water. Slide the Pad onto the Arm.

Attach a Press Handle (27) to the Right Butterfly Arm (26) with two M8 x 20mm Button Head Screws (51). Slide the Long Pad (54) down so that the bottom is flush with the lower end of the Arm. Wet the Press Handle with soapy water. Slide a Long Handgrip (28) onto the Press Handle. Press a 25mm Round Inner Cap (29) into the Press Handle.

Lubricate an M10 x 50mm Bolt (100) with grease. Attach a Pivot Bracket (70) to the Right Butterfly Arm (26) with the Bolt and an M10 Nylon Locknut (87). **Do not overtighten the Nylon Locknut; the Pivot Bracket must be able to pivot easily.** Repeat this step with the Left Butterfly Arm (25).

17. Lubricate an M10 x 80mm Button Head Bolt (104) and both sides of two Plastic Washers (56) with grease. Attach the Right Butterfly Arm (26) to the Butterfly Frame (47) with the Bolt, the two Plastic Washers, two Butterfly Caps (57), two M10 Washers (91), and an M10 Nylon Locknut (87) as shown. **Make sure that the recessed sides of the Plastic Washers are fitted over the welded bushing in the Butterfly Arm. Do not overtighten the Locknut; the Butterfly Arm must be able to pivot easily.**

Repeat this step with the Left Butterfly Arm (25).

## CABLE ASSEMBLY

18. **IMPORTANT: Refer to the Cable Identification Chart on page 26 for help identifying the cables. Do not overtighten the bolts and nuts attaching the pulleys. The pulleys must be able to turn freely.**

Locate and open the parts bags labeled "CABLE ASSEMBLY" and "PULLEYS."

Lubricate the M10 x 165mm Bolt (30) with grease. Attach the Swivel Cage (76) to the Swivel Carriage (46) with the Bolt and an M10 Nylon Locknut (87).

Locate the Swivel High Cable (74), which is 3213mm long and has a ball on one end and a threaded bolt on the other end. Wrap the Cable around a 90mm Pulley (78). Attach two Pulleys to the Swivel Cage (76) with two M10 x 45mm Bolts (93) and two M10 Nylon Locknuts (87).

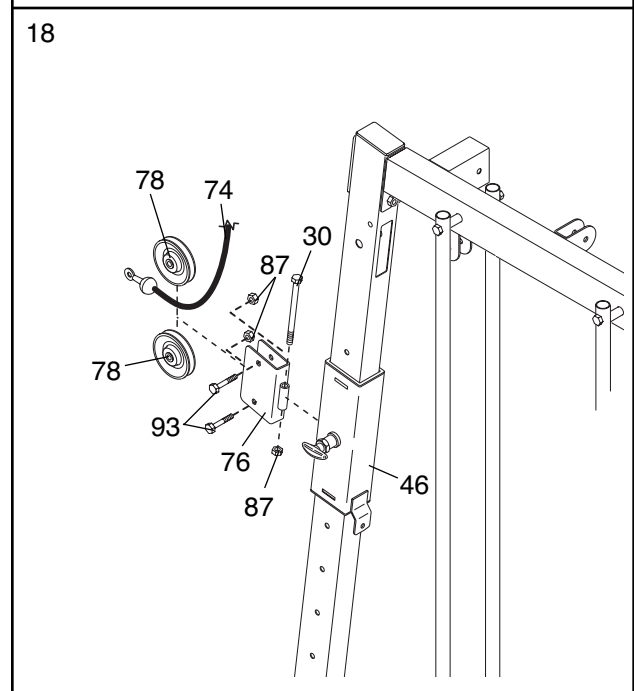
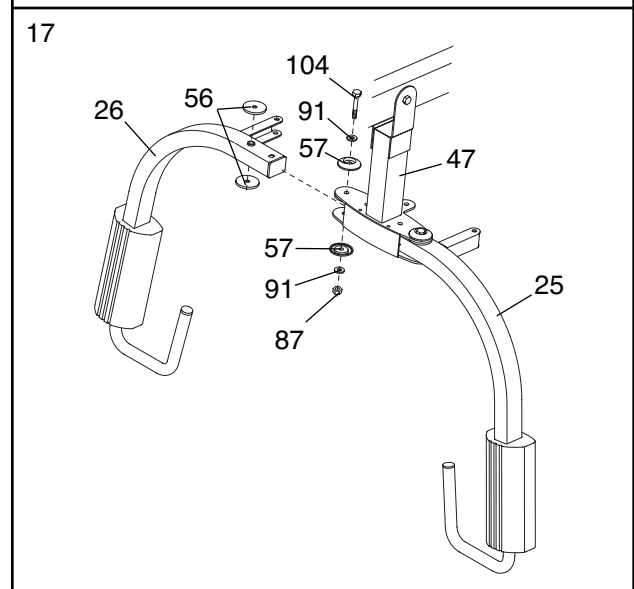
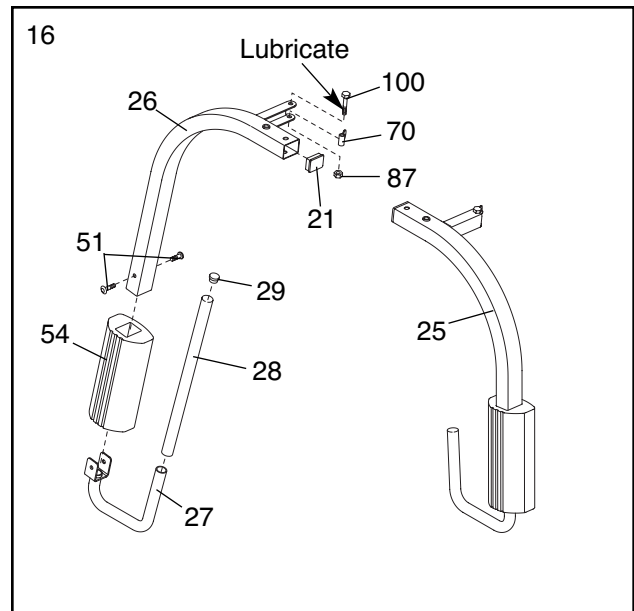

19. Route the Swivel High Cable (74) through the Swivel Upright (5) and over a 115mm Pulley (119). Attach the Pulley inside the Upright with an M10 x 65mm Bolt (18), two M10 Washers (91), two 12mm Spacers (89), and an M10 Nylon Locknut (87).

Attach an M10 x 65mm Bolt (18), two M10 Washers (91), and an M10 Nylon Locknut (87) to the Swivel Upright (5).

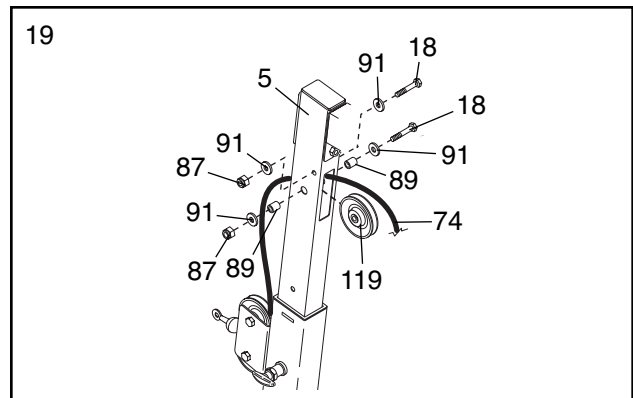

20. **Remove the preattached 90mm Pulleys (78) from the Small Pulley Plates (31).**

Wrap the Swivel High Cable (74) over a 90mm Pulley (78). Attach the Pulley and a Cable Trap (68) to the second set of holes from the top of the Small Pulley Plates (31) with an M10 x 50mm Bolt (100) and an M10 Nylon Locknut (87). **Make sure the Cable Trap is turned to hold the Cable in the groove of the Pulley.**

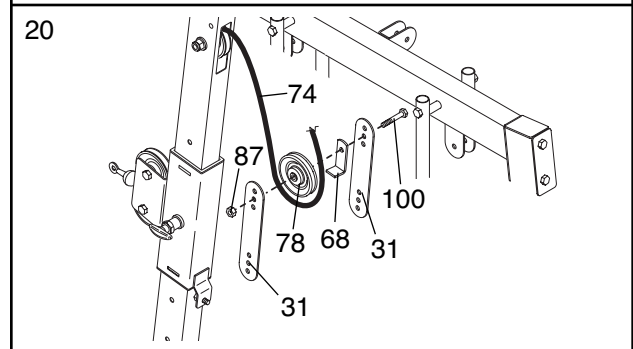

21. Wrap the Swivel High Cable (74) over a 115mm Pulley (119). Attach the Pulley inside of the indicated bracket on the Top Frame (6) with M10 x 45mm Bolt (93) and an M10 Nylon Locknut (87).

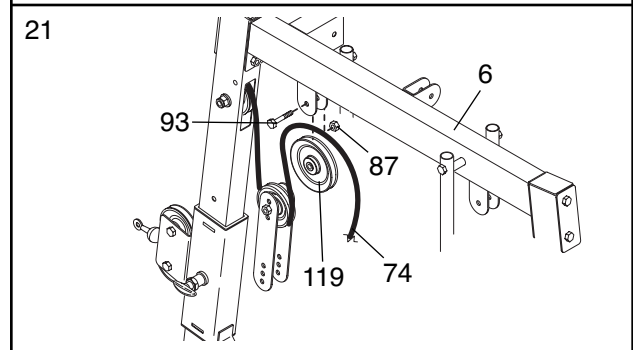

22. Lift the Weight Tube (43) and the Top Weight (45) closest to the Swivel Upright (5). Make sure that the small pin on the Weight Tube is inside of the groove under the Top Weight.

Insert a Weight Pin (50) into the stack of Weights (44). Place a 50mm Washer (1) on top of the Weight Tube (43). Tighten an M12 Nut (118) halfway onto the end of the Swivel High Cable (74). Screw the end of the Cable two full turns into the Weight Tube. Then, tighten the M12 Nut against the Washer.

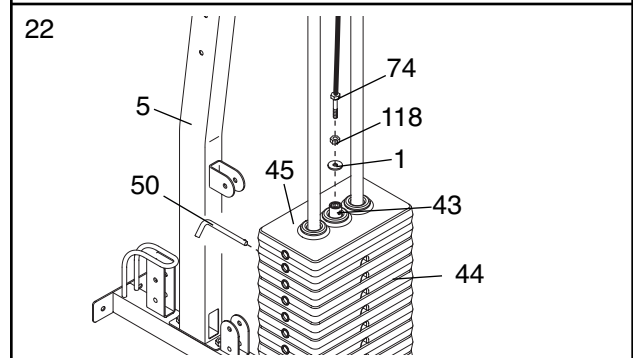

23. **Locate the Swivel Cable (17), which is 2930mm long and has an eyelet on each end.** Attach the Cable inside the Top Frame (6) with an M10 x 65mm Bolt (18), two M10 Washers (91), and an M10 Nylon Locknut (87).

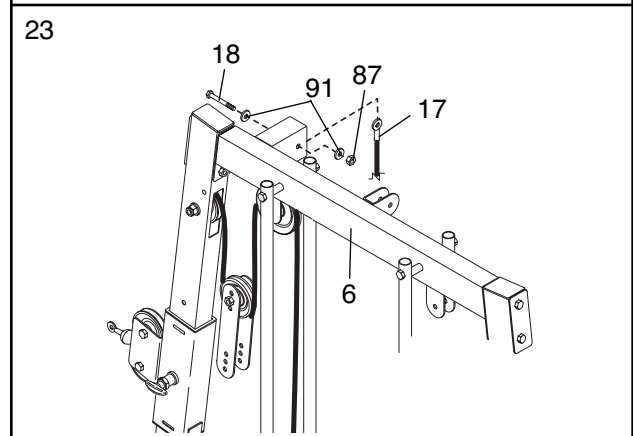

24. **Remove the preattached 90mm Pulleys (78) from the Offset Double “U”-bracket (61).**

Wrap the Swivel Cable (17) around a 90mm Pulley (78). Attach the Pulley to the Offset Double “U”-bracket (61) with an M10 x 45mm Bolt (93) and an M10 Nylon Locknut (87).

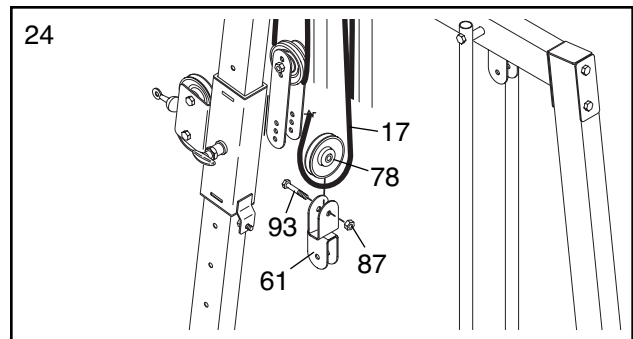

25. Wrap the Swivel Cable (17) around a 90mm Pulley (78). Attach the Pulley and a Cable Trap (68) to the next to bottom hole in the Small Pulley Plates (31) with an M10 x 50mm Bolt (100) and an M10 Nylon Locknut (87). **Make sure the Cable Trap is turned to hold the Cable in the groove of the Pulley.**

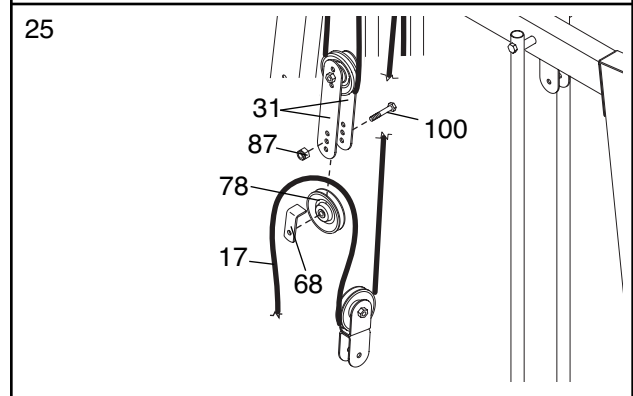

26. Wrap the Swivel Cable (17) around a 90mm Pulley (78). Attach the Pulley and a Long Cable Trap (102) to the bracket on the Swivel Upright (5) with an M10 x 50mm Bolt (100) and an M10 Nylon Locknut (87). **Make sure the Cable Trap is turned to hold the Cable in the groove of the Pulley.**

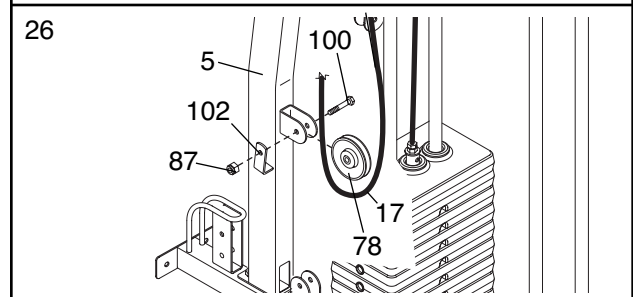

27. Attach the end of the Swivel Cable (17) to the bracket on the Swivel Carriage (46) with an M10 x 20mm Bolt (86) and an M10 Nylon Locknut (87).

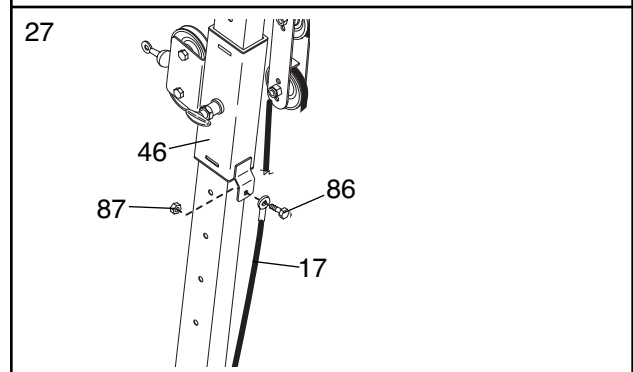

28. **Locate the Lat Cable (88), which is 2263mm long and has a ball on one end and an eyelet on the other.** Route the eyelet end of the Cable up through the Butterfly Top Frame (7) and around a 90mm Pulley (78). Attach the Pulley inside of the Butterfly Top Frame with an M10 x 65mm Bolt (101), two M10 Washers (91), two 12mm Spacers (89), and an M10 Nylon Locknut (87).

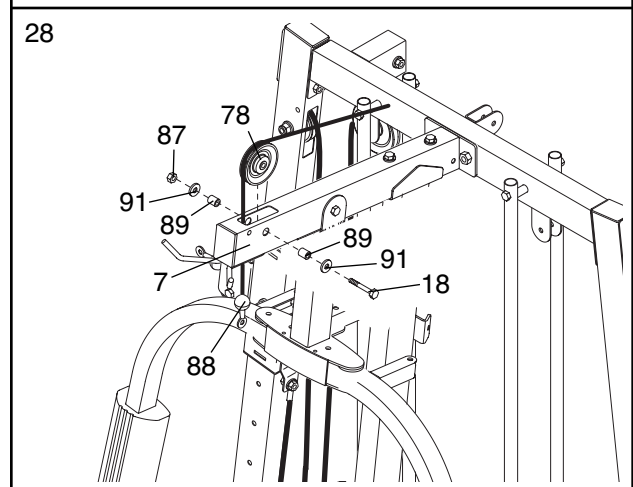



29. Wrap the Lat Cable (88) around a 90mm Pulley (78). Attach the Pulley and a Long Cable Trap (102) to the Top Frame (6) with an M10 x 50mm Bolt (100) and an M10 Nylon Locknut (87). **Make sure the Cable Trap is turned to hold the Cable in the groove of the Pulley.**

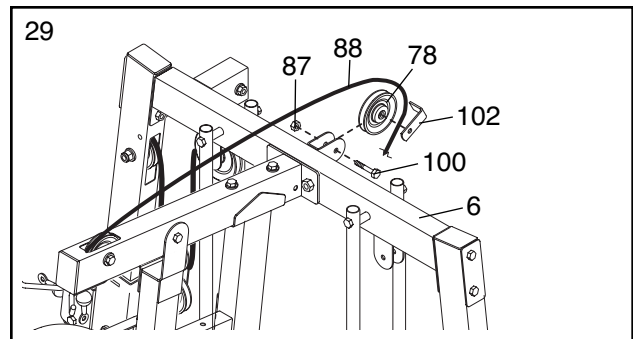

30. **Remove the preattached 90mm Pulleys (78) from the Pulley Plates (63).**

Wrap the Lat Cable (88) around a 90mm Pulley (78). Attach the Pulley and a Cable Trap (68) to the second set of holes from the top of the Pulley Plates (63) with an M10 x 50mm Bolt (100) and an M10 Nylon Locknut (87). **Make sure the Cable Trap is turned to hold the Cable in the groove of the Pulley.**

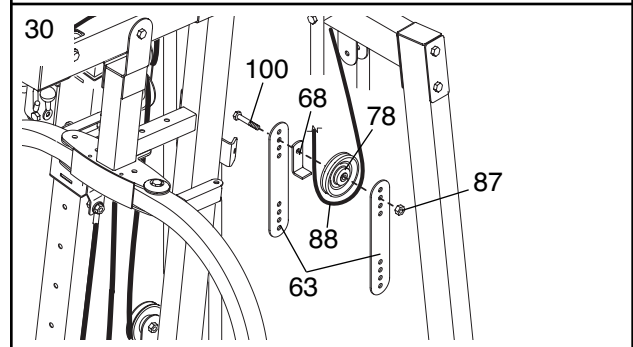

31. Attach the end of the Lat Cable (88) inside of the Butterfly Top Frame (7) with an M10 x 65mm Bolt (18), two M10 Washers (91), and an M10 Nylon Locknut (87).

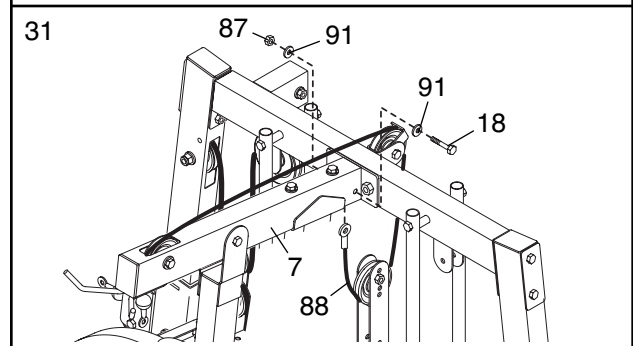

32. **Locate the Butterfly Cable (69), which is the shortest Cable.** Attach the Cable to the Pivot Bracket (70) on the Left Butterfly Arm (25) with an M8 x 20mm Shoulder Bolt (103) and an M8 Nylon Locknut (34).

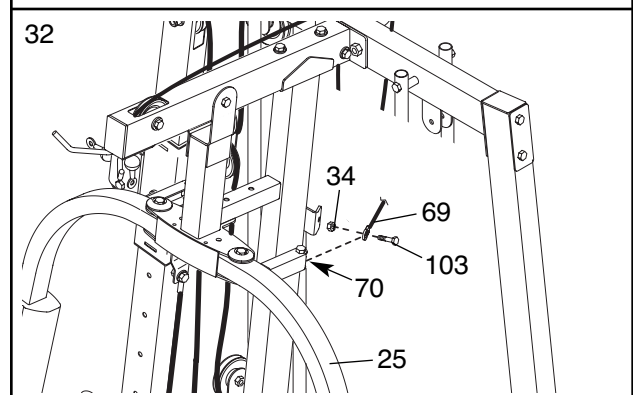

33. Wrap the Butterfly Cable (69) over a "V"-pulley (55). Attach the Pulley and a Long Cable Trap (102) to the indicated bracket on the Butterfly Upright (3) with an M10 x 60mm Bolt (59) and an M10 Nylon Locknut (87). **Make sure that the Long Cable Trap is turned to hold the Cable in the groove of the Pulley.**

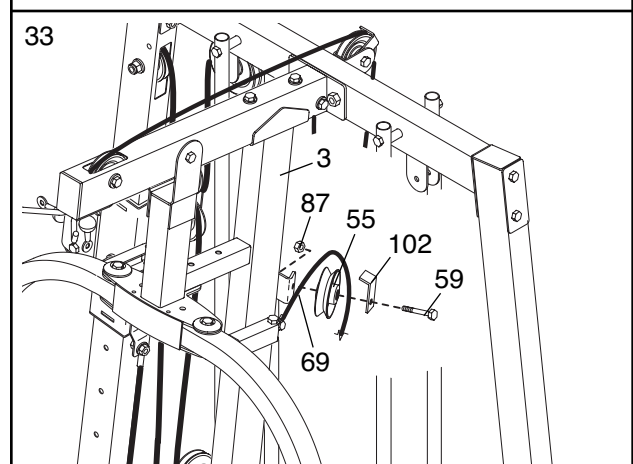

34. **Remove the preattached 90mm Pulleys (78) from the Double "U"-bracket (62).**

Wrap the Butterfly Cable (69) under a 90mm Pulley (78). Attach the Pulley to the Double "U"-bracket (62) with an M10 x 45mm Bolt (93) and an M10 Nylon Locknut (87).

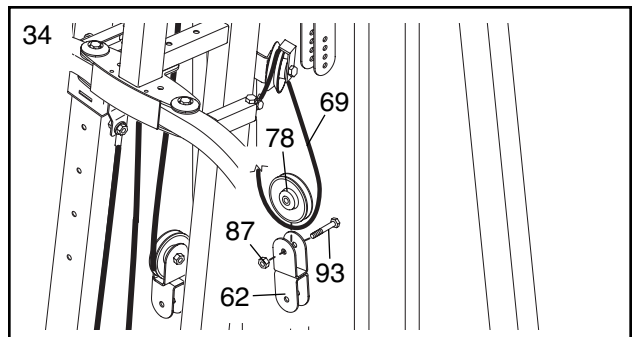

35. Wrap the Butterfly Cable (69) over a "V"-pulley (55). Attach the Pulley and a Long Cable Trap (102) to the other side of the bracket on the Butterfly Upright (3) with an M10 x 60mm Bolt (59) and an M10 Nylon Locknut (87). **Make sure that the Long Cable Trap is turned to hold the Cable in the groove of the Pulley.**

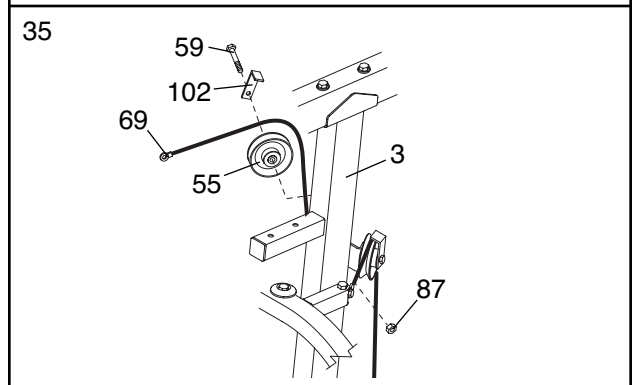

36. Attach the Butterfly Cable (69) to the Pivot Bracket (70) on the Right Butterfly Arm (26) with an M8 x 20mm Shoulder Bolt (103) and an M8 Nylon Locknut (34).

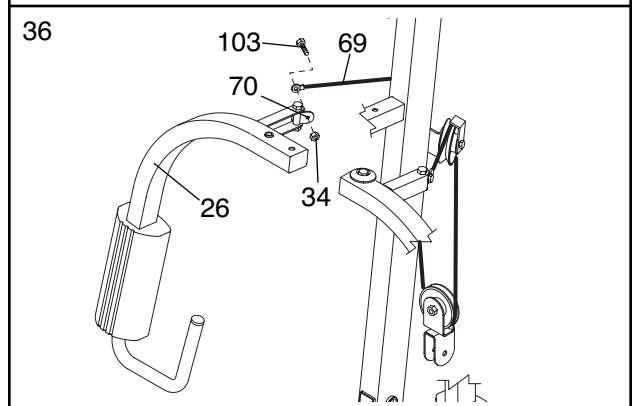

37. **Locate the Leg Lever Cable (75), which is 2505mm long and has an eyelet on one end and a threaded pin on the other end.** Route the eyelet end of the Cable through the Seat Upright (9) and attach it to the tab on the Leg Lever (10) with an M8 x 20mm Shoulder Bolt (103) and an M8 Nylon Locknut (34).

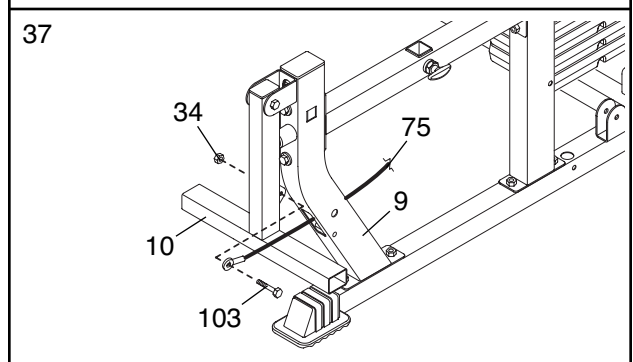

38. Attach a 90mm Pulley (78) inside of the Seat Upright (9) with an M10 x 65mm Bolt (18), two M10 Washers (91), two 12mm Spacers (89), and an M10 Nylon Locknut (87), as shown.

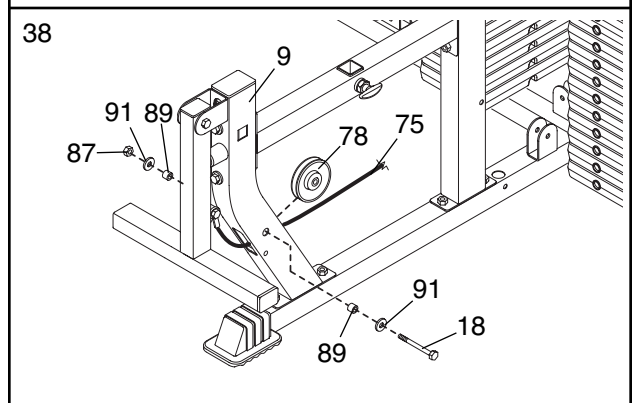



39. Route the Leg Lever Cable (75) under a 115mm Pulley (119). Attach the Pulley and a Large Cable Trap (113) to the indicated side of the Butterfly Upright (3) with an M10 x 95mm Bolt (92), an M10 Washer (91), and an M10 Nylon Locknut (87). **Make sure that the Large Cable Trap is turned to hold the Cable in the groove of the Pulley.**

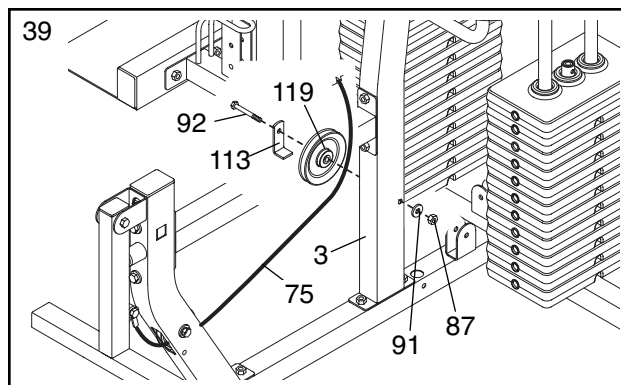

40. Wrap the Leg Lever Cable (75) over a 90mm Pulley (78). Attach the Pulley to the Double "U"-bracket (62) with an M10 x 45mm Bolt (93) and an M10 Nylon Locknut (87).

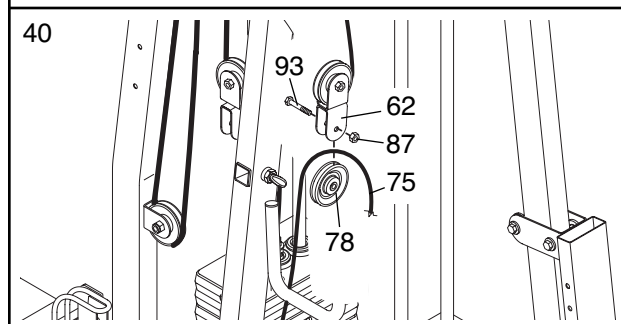

41. **Remove the preattached 90mm Pulley (not shown) from the "U"-bracket (64).**

Attach the end of the Leg Lever Cable (75) to the "U"-bracket (64) with an M8 Washer (90) and an M8 Nylon Locknut (34). **Note: Do not completely tighten the Locknut; it should be threaded only two turns onto the end of the Cable, as shown in the inset drawing.**

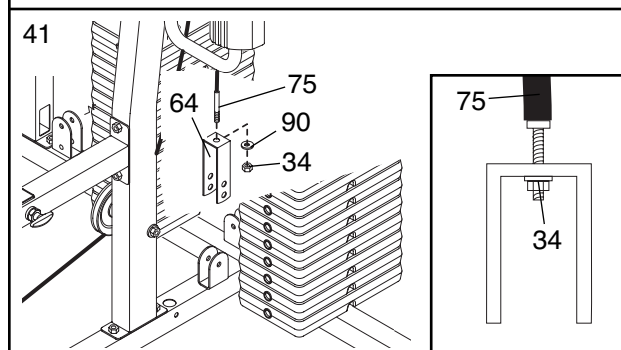

42. **Locate the Swivel Low Cable (72), which is the only remaining cable that has an eyelet on one end and a ball on the other end.** Route the eyelet end of the Cable through the cage on the Long Base (101) and through the Swivel Upright (5), as shown. Make sure the Cable is over the short bar inside the cage.

Attach a 90mm Pulley (78) to the indicated bracket on the Long Base (101) with an M10 x 45mm Bolt (93) and an M10 Nylon Locknut (87). **Make sure the Cable is in the groove of the Pulley.**

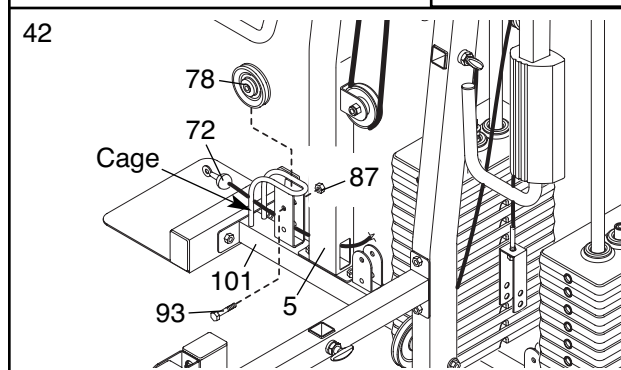

43. Wrap the Swivel Low Cable (72) under a 90mm Pulley (78). Attach the Pulley to the indicated bracket on the Long Base (101) with an M10 x 45mm Bolt (93) and an M10 Nylon Locknut (87).

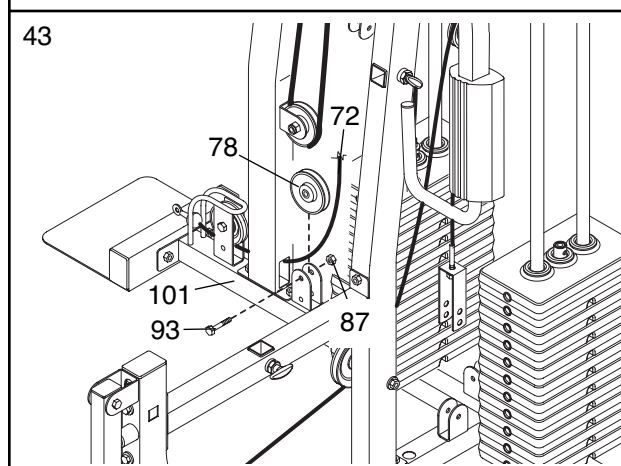

44. Wrap the Swivel Low Cable (72) over a 90mm Pulley (78). Attach the Pulley to the Offset Double "U"-bracket (61) with an M10 x 45mm Bolt (93) and an M10 Nylon Locknut (87).

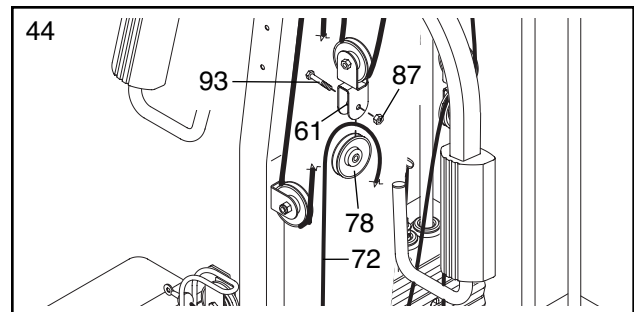

45. Wrap the Swivel Low Cable (72) under a 90mm Pulley (78). Attach the Pulley to the indicated bracket on the Long Base (101) with an M10 x 45mm Bolt (93) and an M10 Nylon Locknut (87).

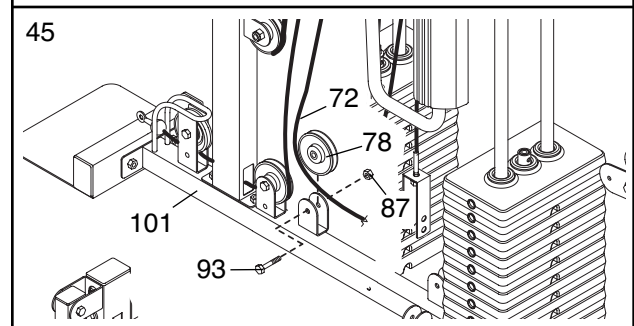

46. Route the Swivel Low Cable (72) under the indicated stack of Weights (44).

Wrap the Swivel Low Cable (72) under a 90mm Pulley (78). Attach the Pulley to the indicated bracket on the Long Base (101) with an M10 x 45mm Bolt (93) and an M10 Nylon Locknut (87).

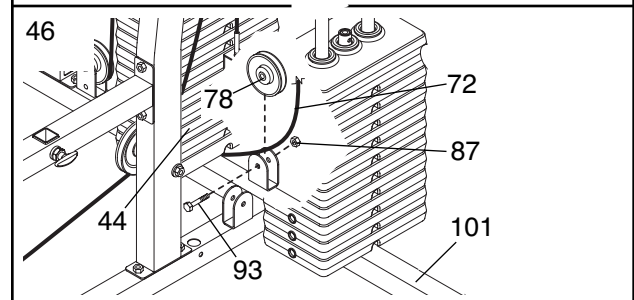

47. Wrap the Swivel Low Cable (72) over a 90mm Pulley (78). Attach the Pulley and a Cable Trap (68) between the indicated holes in the Pulley Plates (63) with an M10 x 50mm Bolt (100) and an M10 Nylon Locknut (87). **Make sure that the Cable Trap is turned to hold the Cable in the groove of the Pulley.**

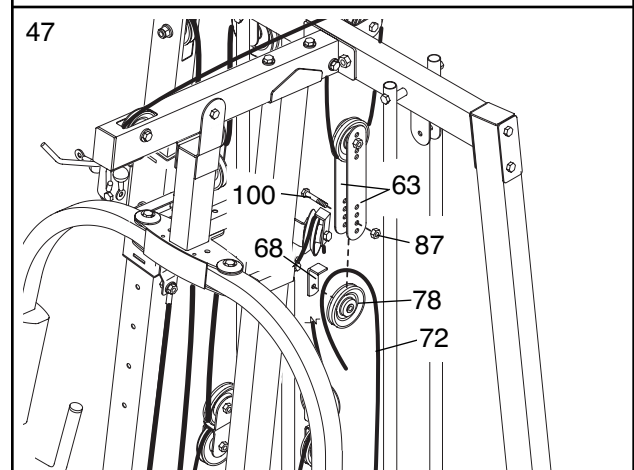

48. Wrap the Swivel Low Cable (72) under a 90mm Pulley (78). Attach the Pulley to the indicated bracket on the Short Base (2) with an M10 x 45mm Bolt (93) and an M10 Nylon Locknut (87).

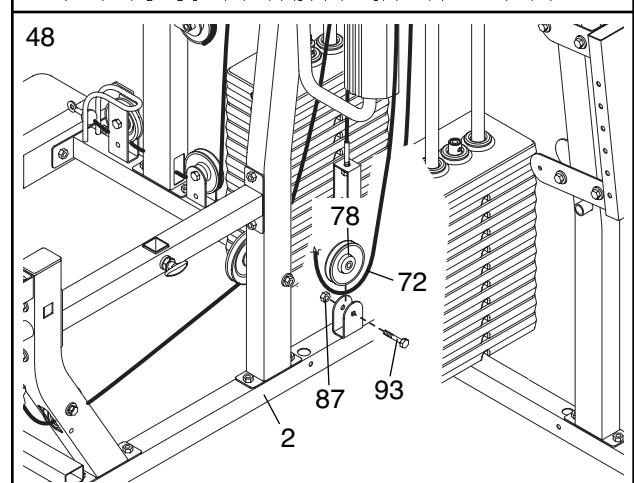

49. Wrap the Swivel Low Cable (72) over a 90mm Pulley (78). Attach the Pulley and a Cable Trap (68) between the lower set of holes in the "U"-bracket (64) with an M10 x 50mm Bolt (100) and an M10 Nylon Locknut (87). **Make sure that the Cable Trap is turned to hold the Cable in the groove of the Pulley.**

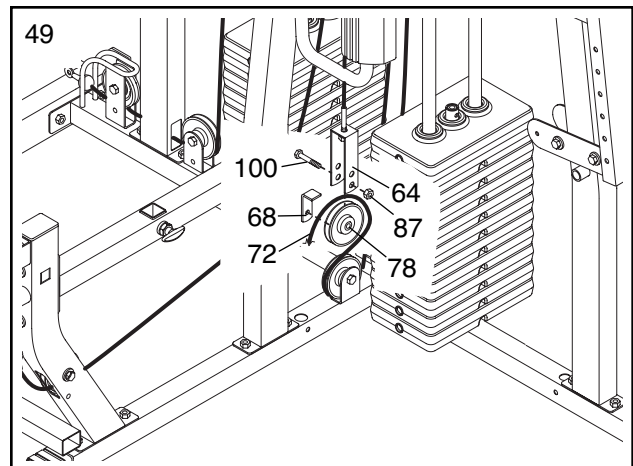

50. Attach the end of the Swivel Low Cable (72) inside of the Short Base (2) with an M10 x 65mm Bolt (18), two M10 Washers (91), and an M10 Nylon Locknut (87).

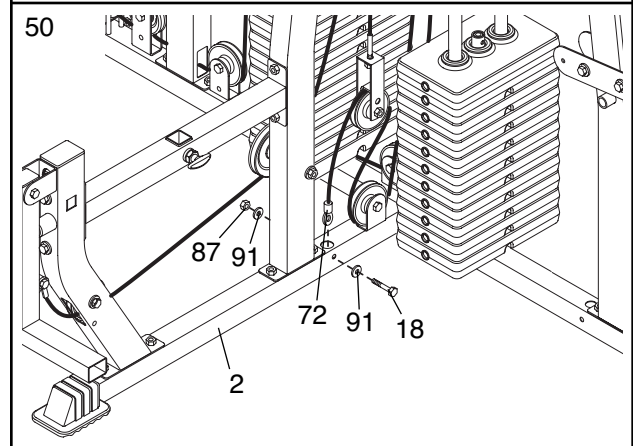

51. **Locate the Squat Cable (73), which is the only remaining cable.** Attach the eyelet end of the Cable inside of the Long Base (101) with an M10 x 65mm Bolt (18), two M10 Washers (91), and an M10 Nylon Locknut (87).

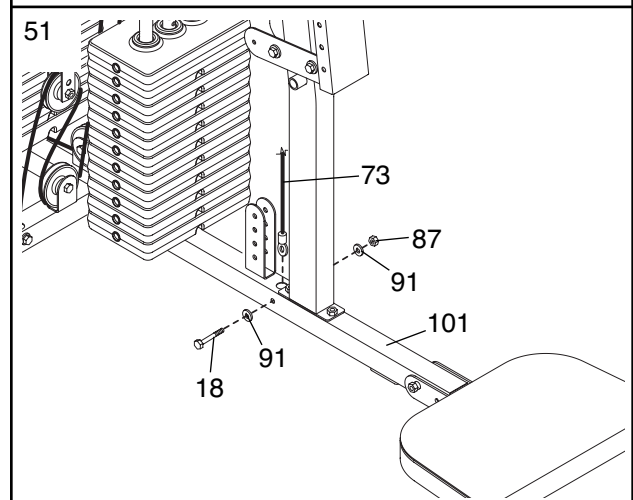

52. Wrap the Squat Cable (73) over a 90mm Pulley (78). Attach the Pulley, a Cable Trap (68), and two 19mm Spacers (98) between the indicated brackets on the Squat Slider (38) with an M10 x 85mm Bolt (96) and an M10 Nylon Locknut (87). **Make sure that the Cable Trap is turned to hold the Cable in the groove of the Pulley.**

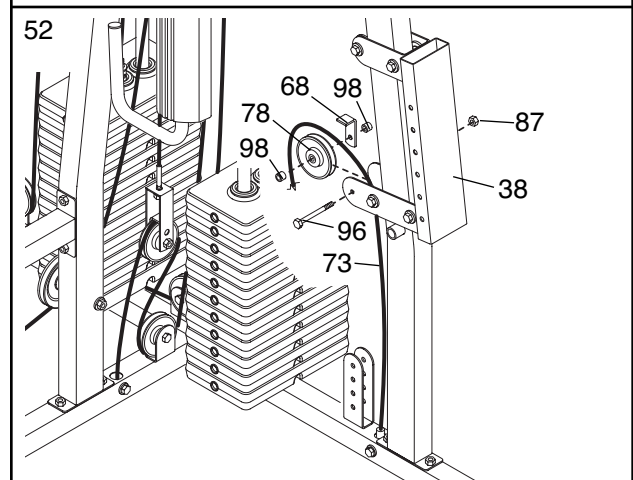

53. Wrap the Squat Cable (73) under a 90mm Pulley (78). Attach the Pulley and a Cable Trap (68) to the second set of holes from the top in the indicated bracket on the Long Base (101) with an M10 x 50mm Bolt (100) and an M10 Nylon Locknut (87). **Make sure that the Cable Trap is turned to hold the Cable in the groove of the Pulley.**

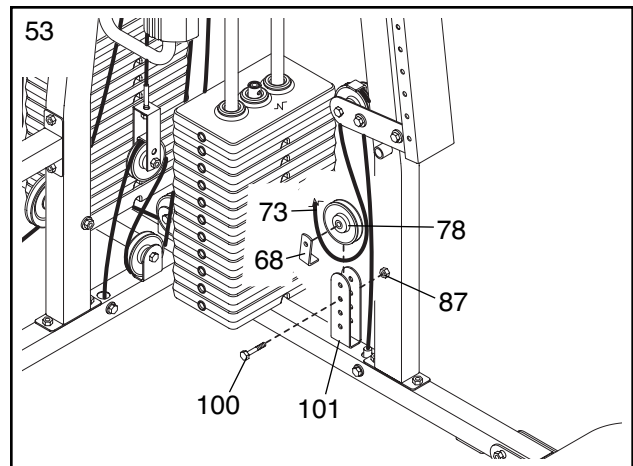

54. Wrap the Squat Cable (73) over a 115mm Pulley (119). Attach the Pulley to the indicated bracket on the Top Frame (6) with an M10 x 45mm Bolt (93) and an M10 Nylon Locknut (87).

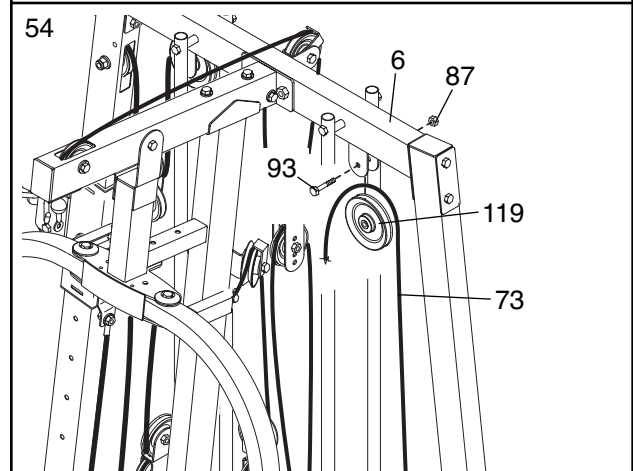

55. Place a 50mm Washer (1) on top of the Weight Tube (43) closest to the Squat Upright (4). Thread a M12 Nut (118) halfway onto the end of the Squat Cable (73).

Lift the Weight Tube (43) and the Top Weight (45) and make sure that the small pin on the Weight Tube is inside of the groove under the Top Weight.

Hold the Weight Tube (43) and the Top Weight (45) a few inches over the weight stack and insert the Weight Pin (50). Screw the end of the Squat Cable (73) two full turns into the Weight Tube. Then, tighten the M12 Nut (118) against the 50mm Washer (1). Remove the Weight Pin and set the Top Weight back on the weight stack. Replace the Pin.

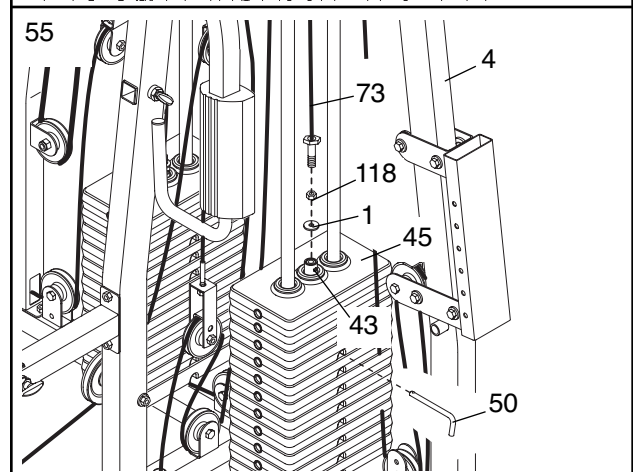

## SEAT ASSEMBLY

56. **Locate and open the parts bag labeled "SEAT ASSEMBLY."**

Insert the Pad Tube (23) into the square hole in the Seat Upright (9). Wet the Pad Tube with soapy water. Slide the two Knee Pads (19) onto the Pad Tube as shown. Press the two Knee Pad Caps (109) into the ends of the Pad Tube.

Slide two Short Pads (20) onto the Leg Lever (10).

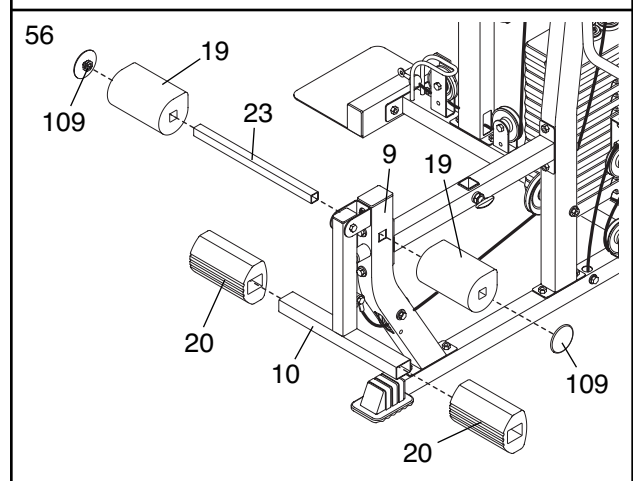



57. Press two 20mm x 40mm Inner Caps (116) and a 25mm x 40mm Square Inner Cap (117) into the Seat Bracket (11).

Attach the Seat (16) to the Seat Bracket (11) with two M6 x 16mm Screws (114), an M6 x 35mm Screw (99), and an M6 Washer (97).

Turn the indicated Adjustment Handle (65) counter-clockwise several turns to loosen it. Next, pull the Handle and insert the Seat Bracket (11) into the Seat Frame (8). Engage the Handle into one of the holes in the Seat Bracket, and then turn the Handle clockwise until it is tight.

58. Press two 20mm x 40mm Inner Caps (116) and a 25mm x 40mm Square Inner Cap (117) into the Backrest Bracket (13).

Attach the Butterfly Backrest (15) to the Backrest Bracket (13) with four M6 x 16mm Screws (114).

Turn the indicated Adjustment Handle (65) counter-clockwise several turns to loosen it. Next, pull the Handle and insert the Backrest Bracket (13) into the Butterfly Upright (3). Engage the Handle into one of the holes in the Backrest Bracket, and then turn the Handle clockwise until it is tight.

59. Wet one end of the Squat Arm (32) with soapy water. Slide a Short Pad (20) onto the Squat Arm as shown.

Attach a Squat Handle (33) to the Squat Arm (32) with two M8 x 20mm Button Head Screws (51). Slide an Outer Cap w/Hole (111) onto the Squat Handle and press it onto the end of the Squat Arm. Wet the Squat Handle with soapy water. Slide an 200mm Handgrip (84) onto the Squat Handle.

**Repeat this step with the other end of the Squat Arm (32).**

60. Attach the Squat Arm (32) to the Squat Bracket (37) with two M10 x 65mm Carriage Bolts (110) and two M10 Nylon Locknuts (87). **Do not tighten the Locknuts yet.**

Finish attaching the Squat Arm (32) to the Squat Bracket (37) with two M10 x 70mm Carriage Bolts (106), two M10 Washers (91), and two M10 Nylon Locknuts (87).

**Tighten all of the M10 Nylon Locknuts (87) used in this step.**

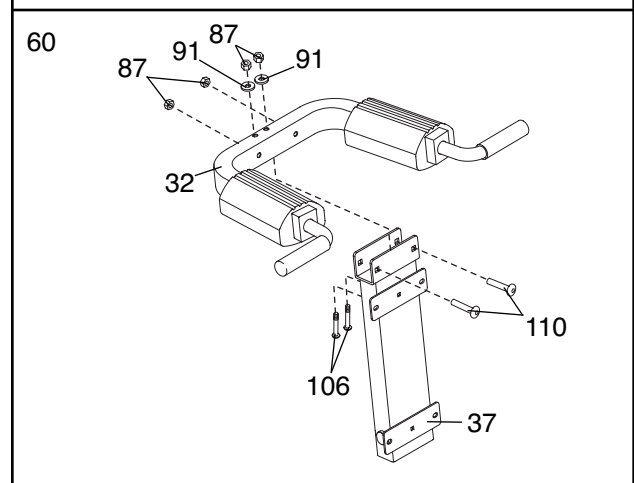
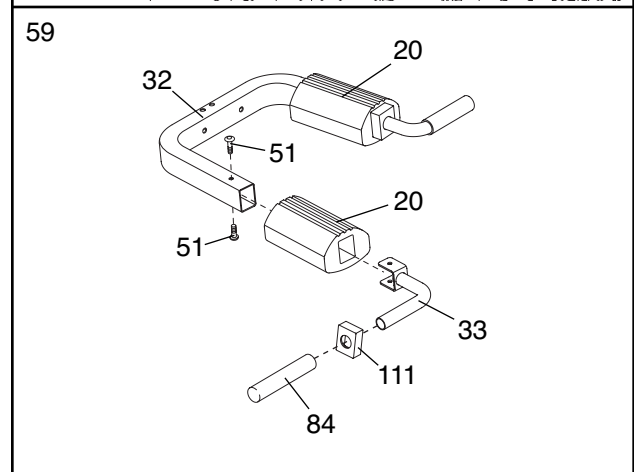
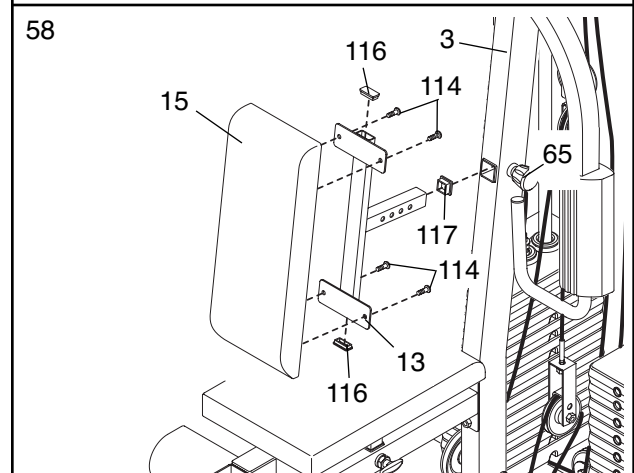
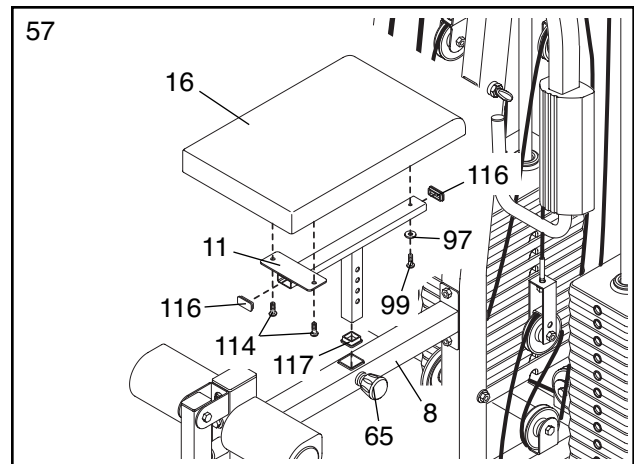

61. Turn the Squat Backrest (35) so that the four screw holes are closer to the bottom of the Squat Backrest than the top. Attach the Squat Backrest to the Squat Bracket (37) with four M6 x 16mm Screws (114).

Fully tighten the Adjustment Knob (115) into the Squat Bracket (37). Turn the knob on the Adjustment Knob counterclockwise several times to loosen it. Next, pull the Knob and slide the Squat Bracket (37) down onto the Squat Slider (38). Engage the Knob into one of the holes in the Squat Slider, and then turn the Knob clockwise until it is tight.

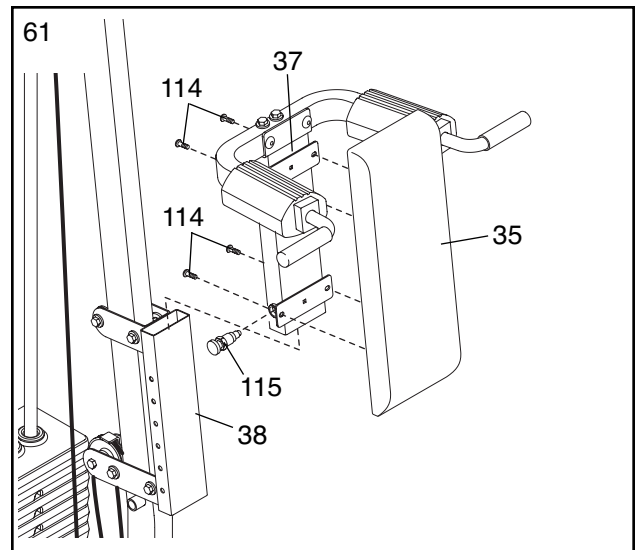

62. Make sure that all parts have been properly tightened. The use of the remaining parts will be explained in ADJUSTMENTS, beginning on the following page.

Before using the weight system, pull each cable a few times to make sure that the cables move smoothly over the pulleys. If one of the cables does not move smoothly, find and correct the problem. **IMPORTANT: If the cables are not properly installed, they may be damaged when heavy weight is used. See the CABLE DIAGRAMS on page 26 and 27 of this manual for proper cable routing. If there is any slack in the cables, you will need to remove the slack by tightening the cables. See TROUBLESHOOTING on page 25.**

# ADJUSTMENTS

The instructions below describe how each part of the weight system can be adjusted. Refer to the exercise guide accompanying this manual to see how the weight system should be set up for various exercises. **IMPORTANT: When attaching the lat bar, row bar, or handle, make sure that the accessories are in the correct starting position for the exercise to be performed. If there is any slack in the cables or chain as an exercise is performed, the effectiveness of the exercise will be reduced.**

## CHANGING THE WEIGHT SETTING

To change the weight setting of either weight stack, insert a Weight Pin (50) under the desired Weight (44) until the bent end of the Weight Pin is touching the Weights. Turn the bent end downward. The weight setting of each weight stack can be changed from 10 pounds to 110 pounds, in 10-pound increments. **Note: Due to the cables and pulleys, the amount of resistance at each exercise station may vary from the weight setting. Use the WEIGHT RESISTANCE CHART on page 24 to find the approximate amount of resistance at each weight station.**

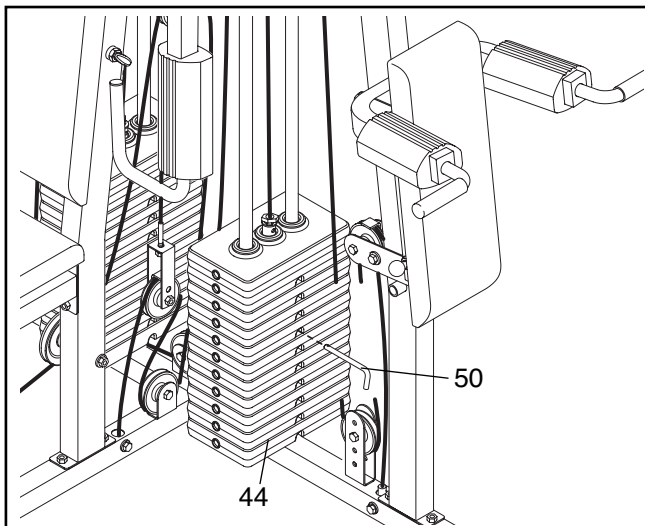

## ATTACHING THE ACCESSORIES TO THE HIGH PULLEY STATION OR THE LOW PULLEY STATION

Attach the Lat Bar (79) to the Lat Cable (88) with a Cable Clip (83). For some exercises, the Chain (81) should be attached between the Lat Bar and the Lat Cable with two Cable Clips. **Adjust the length of the Chain between the Lat Bar and the Lat Cable so the Lat Bar is in the correct starting position for the exercise to be performed.**

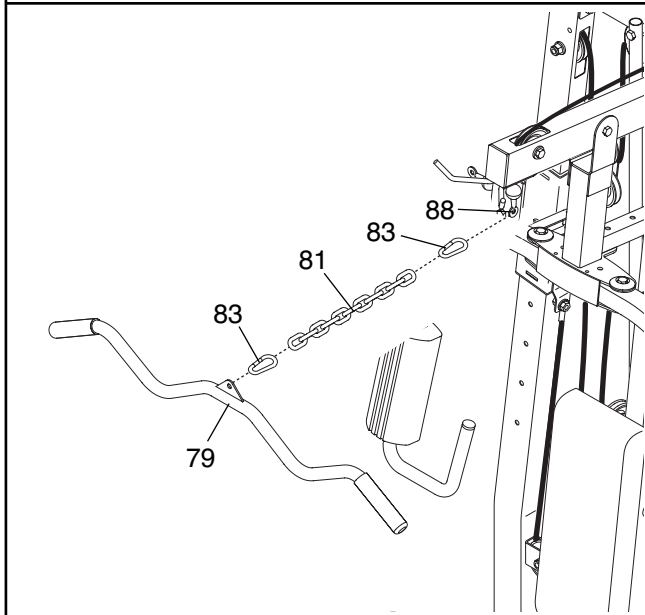

**The Lat Bar (79) can be attached to the Swivel Low Cable (not shown) in the same way.**

The Row Bar (not shown), the Handle (not shown), or Ab Strap (not shown) can be attached to the Lat Cable (88) or the Swivel Low Cable (not shown) in the same way.

## CONVERTING THE BUTTERFLY ARMS

To use the Butterfly Arms (25, 26) as butterfly arms, insert the "L"-pins w/Tethers (60) into the butterfly holes in the Butterfly Upright (3).

To use the Butterfly Arms (25, 26) as press arms, insert the "L"-pins w/Tethers (60) into the press holes in the Butterfly Frame (47).

**Make sure that both "L"-pins w/Tethers (60) are fully inserted into the same set of holes before performing any exercise.**

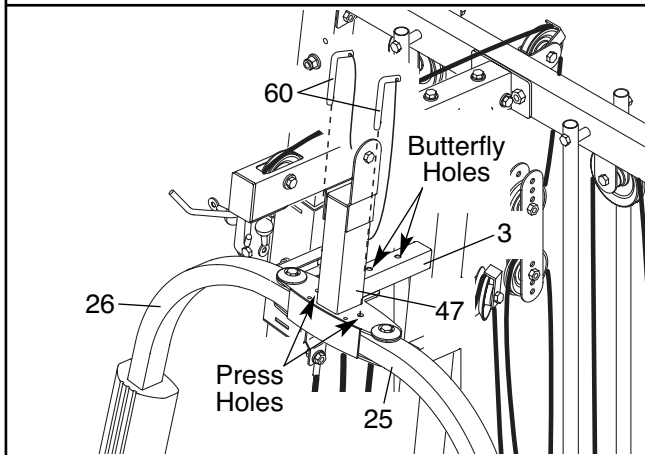



## ADJUSTING THE SQUAT ARM, SEAT, OR BUTTERFLY BACKREST

To adjust the height of the Squat Arm (32), first turn the Adjustment Knob (115) on the Squat Bracket (37) counterclockwise several turns to loosen it. Next, pull the Handle and slide the Squat Bracket up or down to the desired position. Engage the Handle into one of the holes in the Squat Slider (not shown), and then turn the Handle clockwise until it is tight.

The height of the Seat (16), the position of the Butterfly Backrest (15), and the Swivel Carriage (not shown) can be adjusted in the same way using the three Adjustment Handles (65).

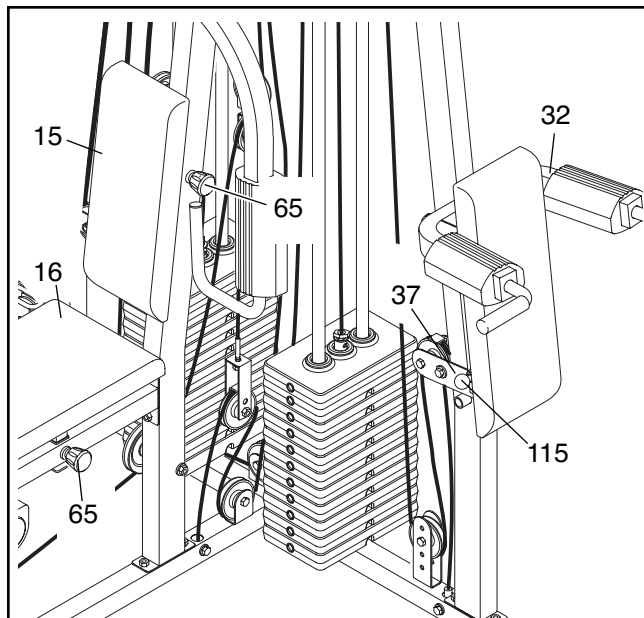

## ADJUSTING THE SQUAT KNEE REST

To use the Squat Knee Rest (41), pivot it down to the position shown and insert the Pin w/Tether (112) into the holes in the Squat Knee Rest and the Long Base (101).

When the Squat Knee Rest (41) is not in use, pivot it up to a vertical position and then insert the Pin w/Tether (112) into the hole in the Long Base (101).

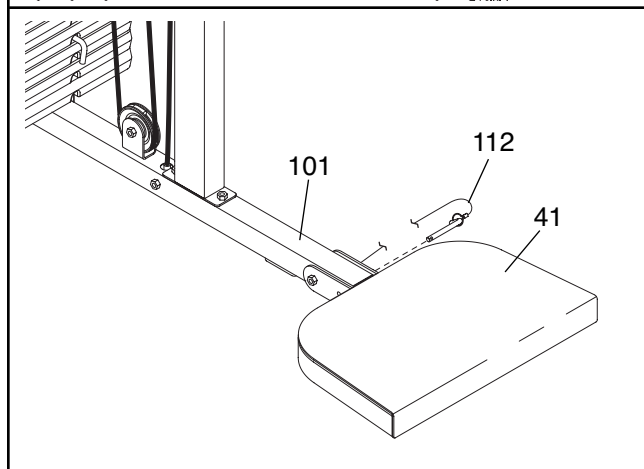

# WEIGHT RESISTANCE CHART

The chart below shows the approximate weight resistance at each weight station. "Top" refers to the 10-pound top weight. The other numbers refer to the 10-pound weight plates. The butterfly arm resistance listed is the resistance for each butterfly arm. **Note: The actual resistance at each weight station may vary due to differences in individual weight plates as well as friction between the cables, pulleys, and weight guides.**

WEIGHT	HIGH PULLEY (lbs.)	LOW PULLEY (lbs.)	LEG LEVER (lbs.)	BUTTERFLY ARM (lbs.)	PRESS ARM (lbs.)	SQUAT STATION (lbs.)	SWIVEL STATION (lbs.)
<b>Top</b>	14	14	22	17	24	59	16
<b>1</b>	25	25	35	26	39	87	26
<b>2</b>	38	36	53	36	55	116	39
<b>3</b>	48	44	67	45	70	136	52
<b>4</b>	61	60	91	54	89	170	59
<b>5</b>	68	70	111	63	104	192	74
<b>6</b>	80	80	122	71	118	203	84
<b>7</b>	96	91	148	80	136	223	90
<b>8</b>	101	104	160	91	154	239	104
<b>9</b>	112	111	184	100	167	254	116
<b>10</b>	122	122	190	108	187	270	122

# TROUBLESHOOTING

Make sure all parts are properly tightened each time the weight system is used. Replace any worn parts immediately. The weight system can be cleaned using a damp cloth and mild non-abrasive detergent. Do not use solvents.

## TIGHTENING THE CABLES

Woven cable, the type of cable used on the weight system, can stretch slightly when it is first used. If there is slack in the cables before resistance is felt, the cables should be tightened. To tighten the cables, first insert the weight pins into the centers of the weight stacks. Slack can be removed from the cables in several ways:

**See drawing 1.** To tighten the Squat Cable (73) or the Swivel High Cable (not shown), first loosen the M12 Nut (118) on the end of the Cable, away from the 50mm Washer (1). Screw the end of the Cable farther into the Weight Tube (43). Then, retighten the Nut against the Washer.

**See drawing 2.** To further tighten the Squat Cable (73), first remove the M10 Nylon Locknut (87), the M10 x 50mm Bolt (100), Cable Trap (68), and 90mm Pulley (78) from the indicated bracket on the Long Base (101). Reattach the Pulley and Cable Trap between a lower set of holes with the Bolt and Nylon Locknut.

**See drawing 3.** To tighten the other five cables, first remove the upper or lower M10 Nylon Locknut (87), M10 x 50mm Bolt (100), 90mm Pulley (78), and Cable Trap (68) from the Pulley Plates (63) or Small Pulley Plates (not shown). Reattach the Pulley and the Cable Trap between a set of holes closer to the center of the Pulley Plates with the Bolt and Locknut.

**See drawing 4.** To remove additional slack, first remove the M10 Nylon Locknut (87), M10 x 50mm Bolt (100), 90mm Pulley (78), and Cable Trap (68) from the "U"-bracket (64). Reattach the Pulley and the Cable Trap between the higher set of holes in the "U"-bracket with the Bolt and Locknut.

Slack can also be removed from the cables by tightening the M8 Nylon Locknut (34) at the end of the Leg Lever Cable (75). To do this you may need to remove the 90mm Pulley (78) from the "U"-Bracket (64).

**Do not overtighten the cables. If the cables are overtightened, the top weights will be lifted off the weight stacks.**

**If a cable slips off the pulleys repeatedly, it may have become twisted. Remove the cable and re-install it.** If the cables need to be replaced, see ORDERING REPLACEMENT PARTS on the back cover of this manual.

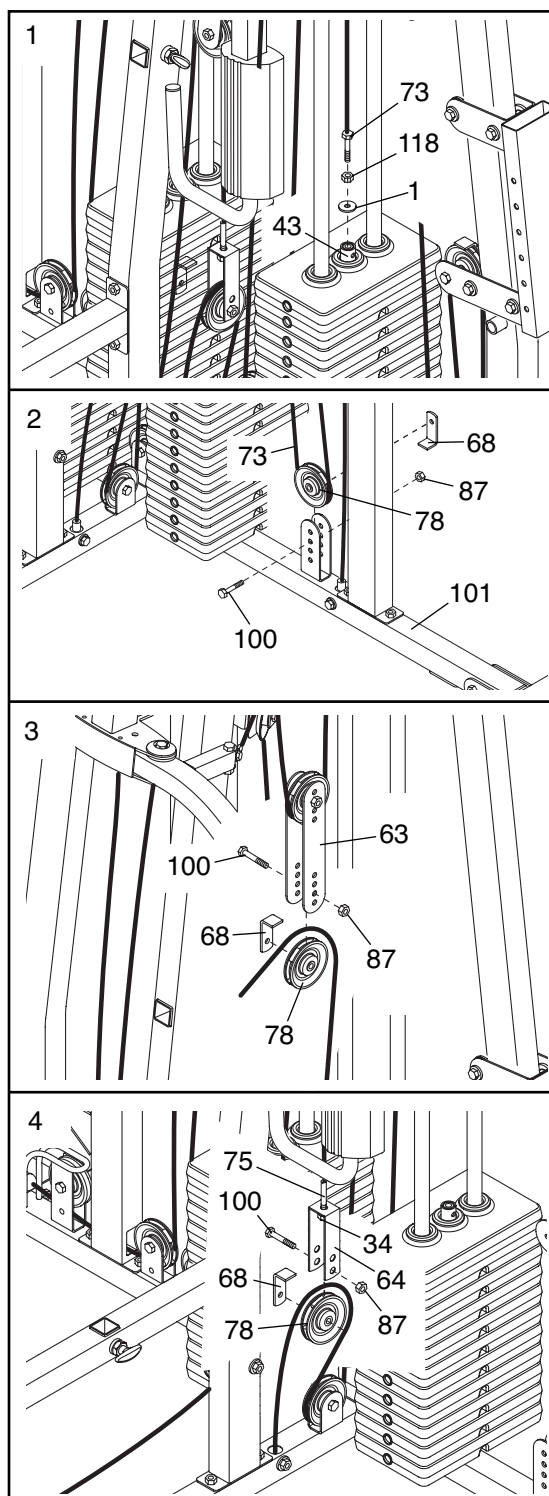

# CABLE DIAGRAMS

The cable identification chart below shows the ends of each cable and the lengths of the cables. The cable diagrams on this page and the following page show the proper routing of the cables. The numbers in the diagrams show the routes of the cables. Use the diagrams to make sure that the cables have been assembled correctly. **IMPORTANT: If the cables have not been correctly routed, the weight system will not function properly and damage may occur.**

Cable Identification Chart	
	Butterfly Cable (69)—1475mm
	Swivel Low Cable (72)—5207mm
	Squat Cable (73)—4425mm
	Swivel High Cable (74)—3213mm
	Leg Lever Cable (75)—2505mm
	Lat Cable (88)—2267mm
	Swivel Cable (17)—2930mm

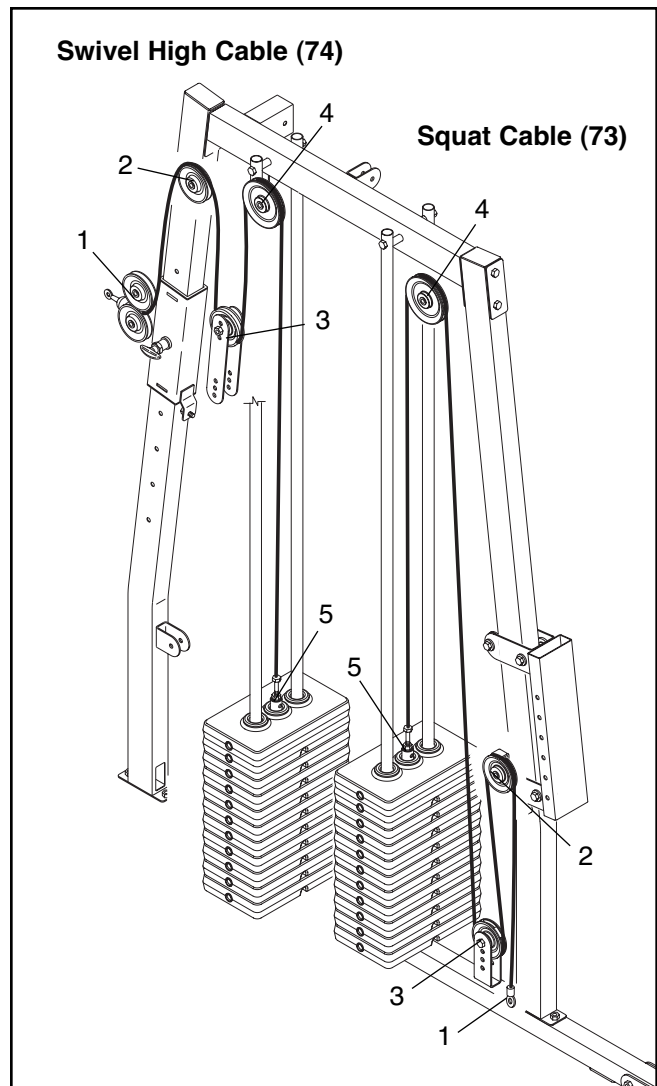
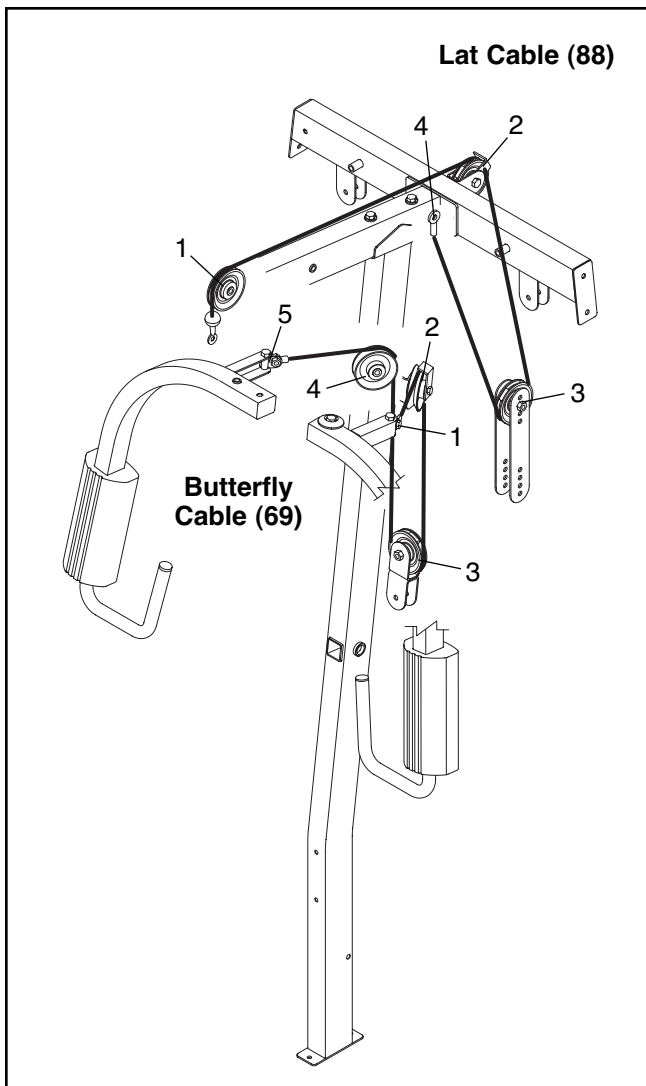

**Leg Lever  
Cable (75)**

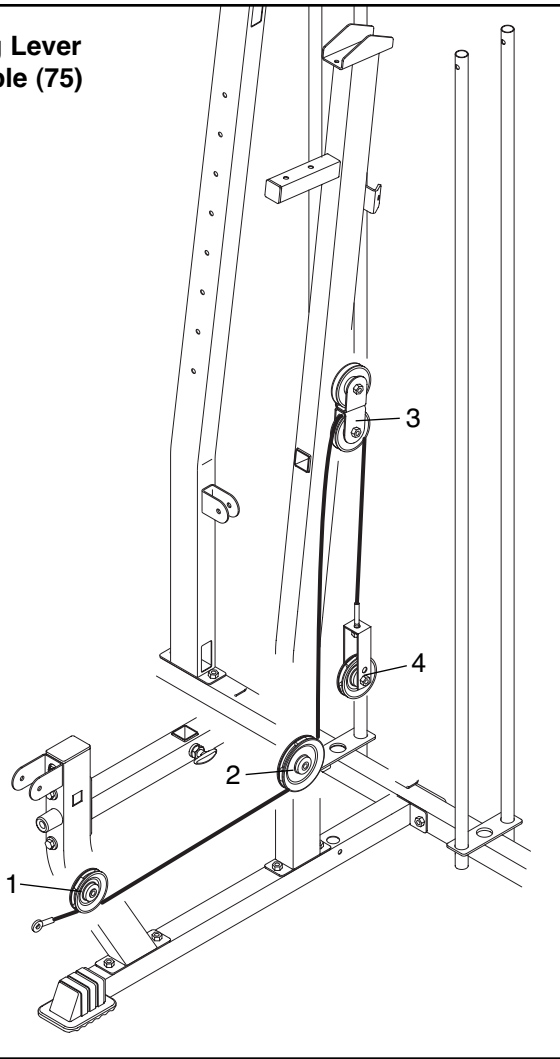

**Swivel Low  
Cable (72)**

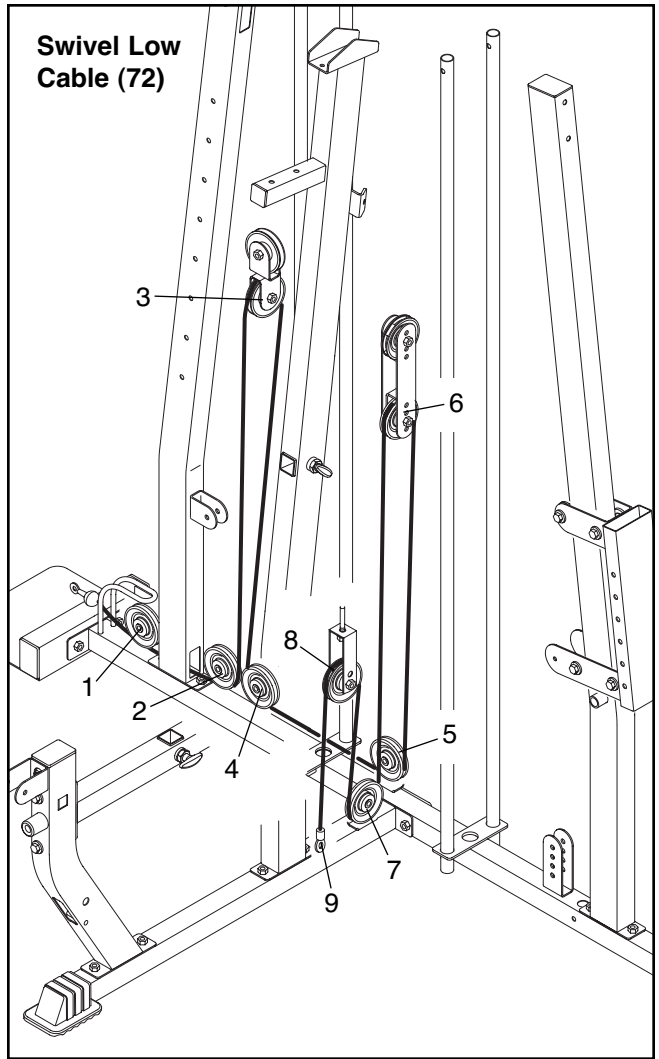

**Swivel Cable (17)**

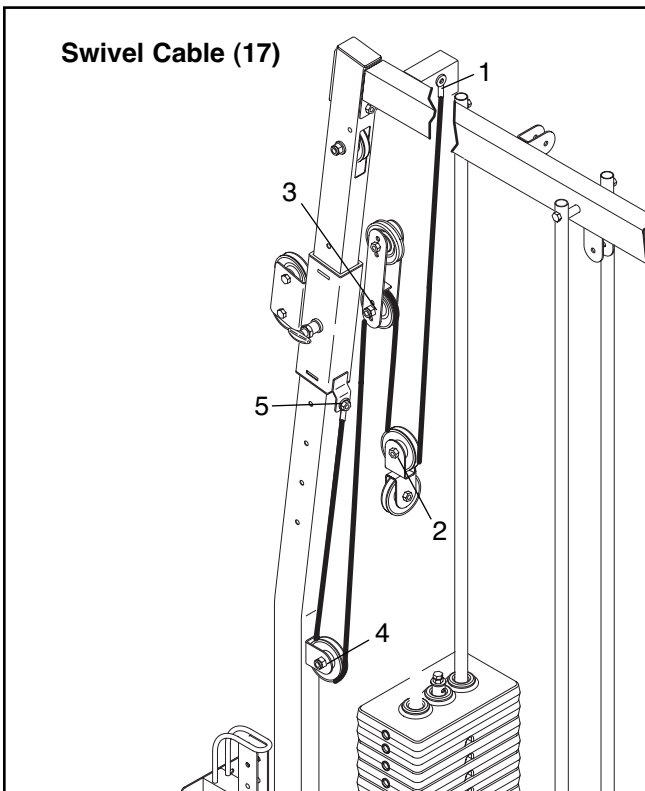

---

# ORDERING REPLACEMENT PARTS

To order replacement parts, simply call our Customer Service Department toll-free at 1-800-999-3756, Monday through Friday, 6 a.m. until 6 p.m. Mountain Time (excluding holidays). To help us assist you, please be prepared to give the following information:

- The MODEL NUMBER of the product (WESY39523)
- The NAME of the product (WEIDER® PRO 3650 weight system)
- The SERIAL NUMBER of the product (see the front cover of this manual)
- The KEY NUMBER and DESCRIPTION of the part(s) (see the PART LIST and EXPLODED DRAWING attached in the center of this manual)

## LIMITED WARRANTY

ICON Health & Fitness, Inc. (ICON), warrants this product to be free from defects in workmanship and material, under normal use and service conditions, for a period of ninety (90) days from the date of purchase. This warranty extends only to the original purchaser. ICON's obligation under this warranty is limited to replacing or repairing, at ICON's option, the product through one of its authorized service centers. All repairs for which warranty claims are made must be pre-authorized by ICON. This warranty does not extend to any product or damage to a product caused by or attributable to freight damage, abuse, misuse, improper or abnormal usage or repairs not provided by an ICON authorized service center; products used for commercial or rental purposes; or products used as store display models. No other warranty beyond that specifically set forth above is authorized by ICON.

ICON is not responsible or liable for indirect, special or consequential damages arising out of or in connection with the use or performance of the product or damages with respect to any economic loss, loss of property, loss of revenues or profits, loss of enjoyment or use, costs of removal or installation or other consequential damages of whatsoever nature. Some states do not allow the exclusion or limitation of incidental or consequential damages. Accordingly, the above limitation may not apply to you.

The warranty extended hereunder is in lieu of any and all other warranties and any implied warranties of merchantability or fitness for a particular purpose is limited in its scope and duration to the terms set forth herein. Some states do not allow limitations on how long an implied warranty lasts. Accordingly, the above limitation may not apply to you.

This warranty gives you specific legal rights. You may also have other rights which vary from state to state.

**ICON HEALTH & FITNESS, INC., 1500 S. 1000 W., LOGAN, UT 84321-9813**

# REMOVE THIS PART IDENTIFICATION CHART FROM THE MANUAL. SAVE THIS PART IDENTIFICATION CHART FOR FUTURE REFERENCE.

This chart is provided to help you identify the small parts used in assembly. The number in parenthesis below each part refers to the key number of the part from the PART LIST in the center of this manual. **Important: Some parts may have been pre-assembled for shipping purposes. If you cannot find a part in the parts bags, check to see if it has been pre-assembled.**

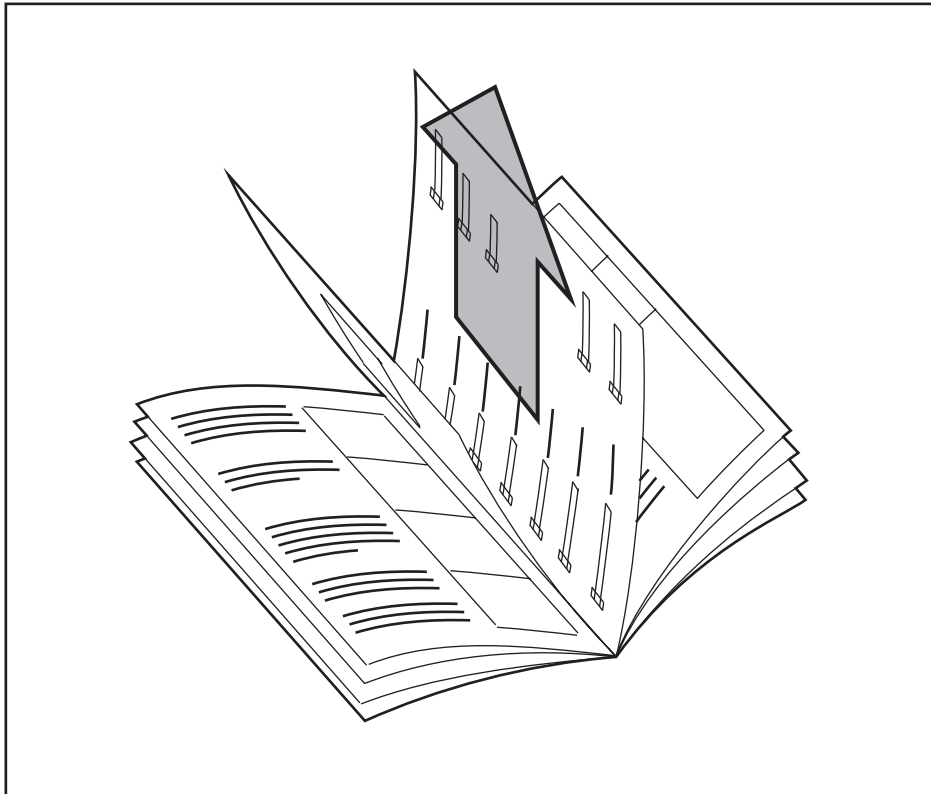

**Note: Assembly is divided into four stages: 1) frame assembly, 2) arm assembly, 3) cable assembly, and 4) seat assembly. The hardware for each stage is packaged in separate bags. WAIT UNTIL YOU BEGIN EACH ASSEMBLY STAGE TO OPEN THE PARTS BAG LABELED FOR THAT ASSEMBLY STAGE.**



# PART IDENTIFICATION CHART – Model No. WESY39523

R0103A

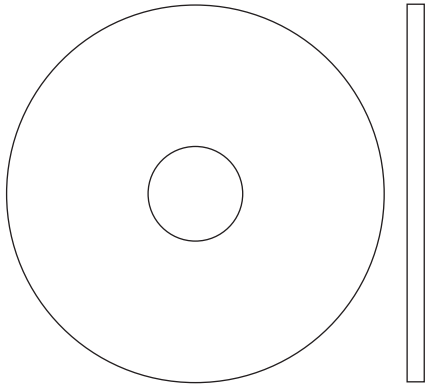

50mm Washer (1)

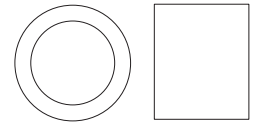

12mm Spacer (89)

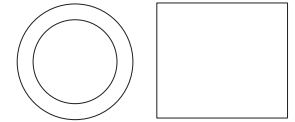

19mm Spacer (98)

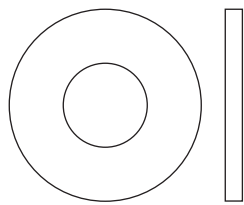

M10 Washer (91)

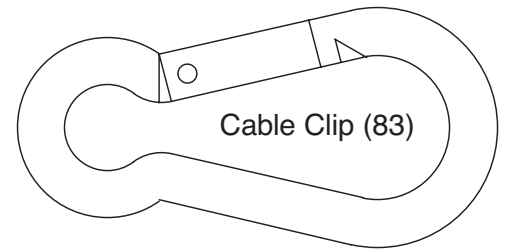

Cable Clip (83)

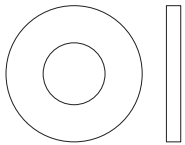

M8 Washer (90)

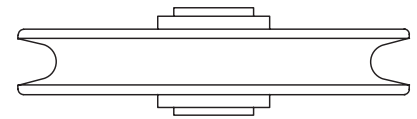

115mm Pulley (119)  
(Not shown to scale)

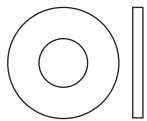

M6 Washer (97)



M4 Washer (120)

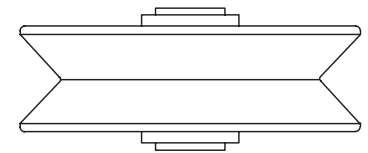

"V"-pulley (55)  
(Not shown to scale)

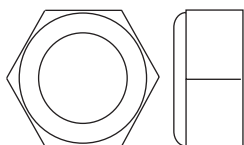

M12 Nut (118)



M10 Nylon Locknut (87)



M8 Nylon Locknut (34)

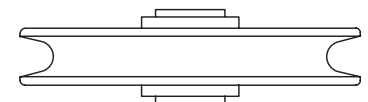

90mm Pulley (78)  
(Not shown to scale)

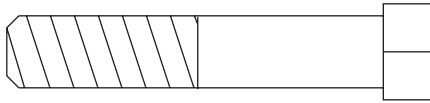

M10 x 50mm Bolt (100)

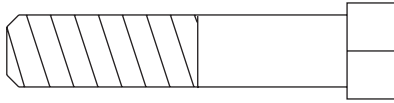

M10 x 45mm Bolt (93)

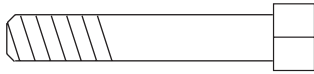

M6 x 35mm Bolt (99)

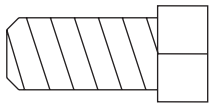

M10 x 20mm Bolt (86)

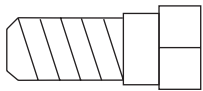

M8 x 20mm  
Shoulder Bolt (103)

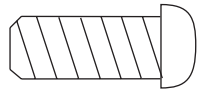

M8 x 20mm Button  
Head Screw (51)

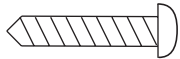

M4 x 20mm Self-  
tapping Screw (14)

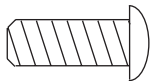

M6 x 16mm Screw (114)



M10 x 60mm Bolt (59)

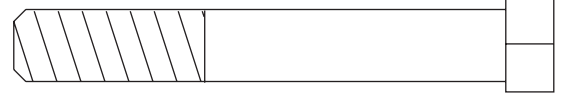

M10 x 65mm Bolt (18)

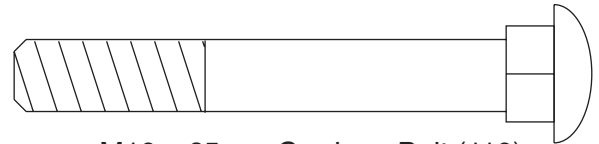

M10 x 65mm Carriage Bolt (110)

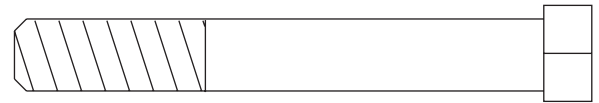

M10 x 70mm Bolt (85)

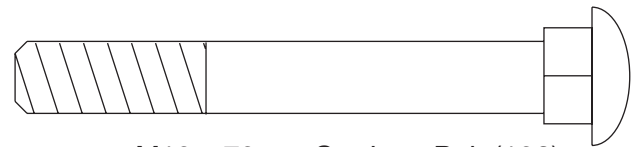

M10 x 70mm Carriage Bolt (106)

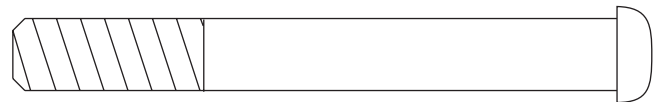

M10 x 80mm Button Head Bolt (104)



M10 x 80mm Bolt (107)

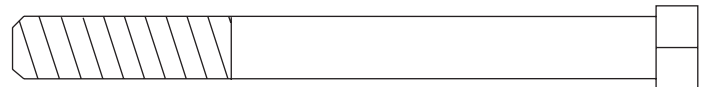

M8 x 85mm Bolt (94)

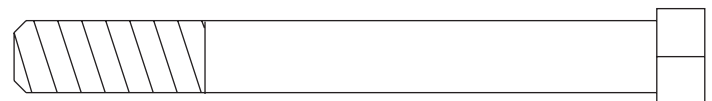

M10 x 85mm Bolt (96)

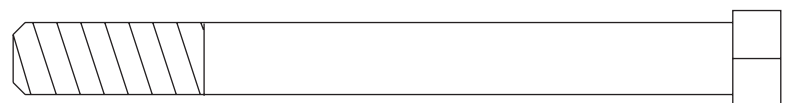

M10 x 95mm Bolt (92)



M10 x 165mm Bolt (30)

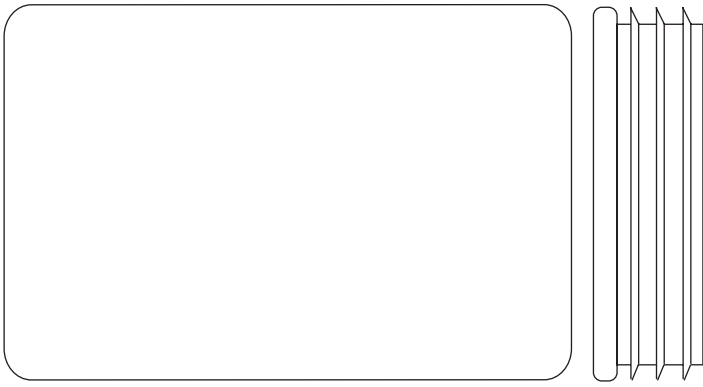

50mm x 75mm Inner Cap (58)

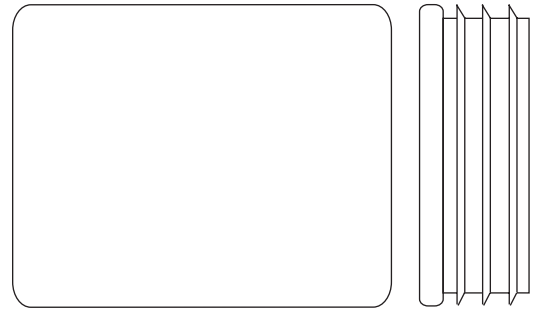

40mm x 50mm Inner Cap (21)

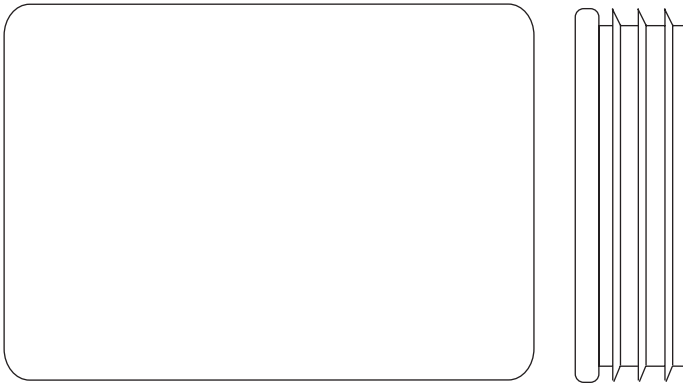

50mm x 70mm Inner Cap (95)

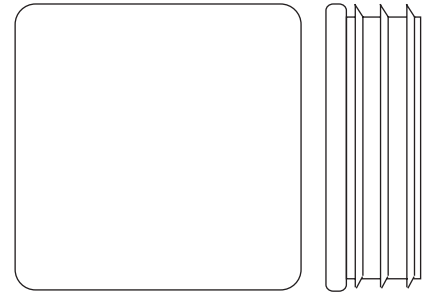

38mm Square Inner Cap (67)

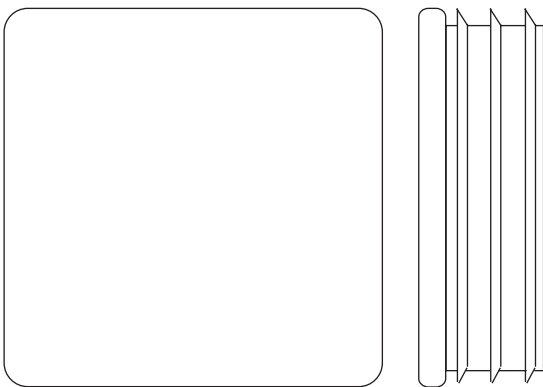

50mm Square Inner Cap (105)

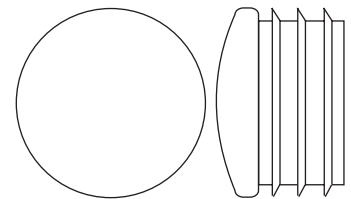

25mm Round Inner Cap (29)



20mm x 40mm Inner Cap (116)



25mm x 40mm Inner Cap (117)

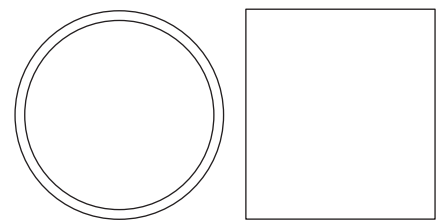

25mm Round Outer Cap (121)

**REMOVE THIS PART LIST/EXPLODED DRAWING  
FROM THE MANUAL.**

**SAVE THIS PART LIST/EXPLODED DRAWING FOR FUTURE REFERENCE**

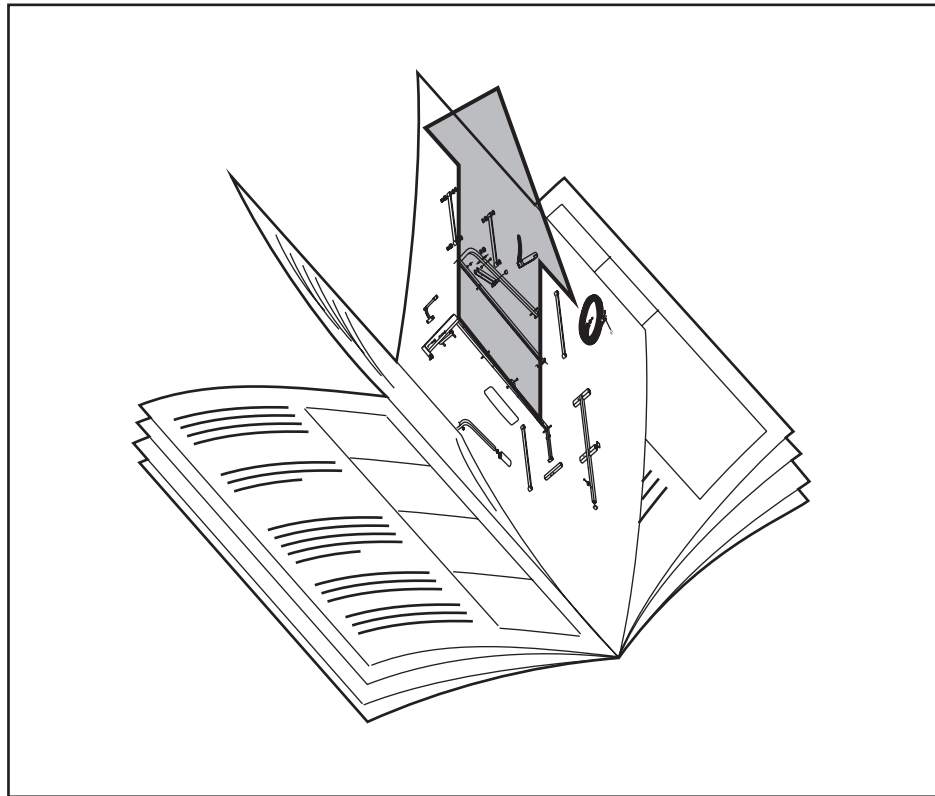

# PART LIST—Model No. WESY39523

R0103A

Key No.	Qty.	Description	Key No.	Qty.	Description	Key No.	Qty.	Description
1	2	50mm Washer	45	2	Top Weight	88	1	Lat Cable
2	1	Short Base	46	1	Swivel Carriage	89	6	12mm Spacer
3	1	Butterfly Upright	47	1	Butterfly Frame	90	1	M8 Washer
4	1	Squat Upright	48	2	Weight Tube Bumper	91	33	M10 Washer
5	1	Swivel Upright	49	4	Weight Bumper	92	13	M10 x 95mm Bolt
6	1	Top Frame	50	2	Weight Pin	93	13	M10 x 45mm Bolt
7	1	Butterfly Top Frame	51	8	M8 x 20mm Button	94	4	M8 x 85mm Bolt
8	1	Seat Frame			Head Screw	95	1	50mm x 70mm Inner Cap
9	1	Seat Upright	52	2	Short Frame Plate			
10	1	Leg Lever	53	1	Foot Plate	96	2	M10 x 85mm Bolt
11	1	Seat Bracket	54	2	Long Pad	97	1	M6 Washer
12	1	Upright Extension	55	2	"V"-pulley	98	2	19mm Spacer
13	1	Backrest Bracket	56	4	Plastic Washer	99	1	M6 x 35mm Screw
14	9	M4 x 20mm Self-tapping Screw	57	4	Butterfly Cap	100	10	M10 x 50mm Bolt
15	1	Butterfly Backrest	58	7	50mm x 75mm Inner Cap	101	1	Long Base
16	1	Seat	59	2	M10 x 60mm Bolt	102	4	Long Cable Trap
17	1	Swivel Cable	60	2	"L"-pin w/Tether	103	3	M8 x 20mm Shoulder Bolt
18	9	M10 x 65mm Bolt	61	1	Offset Double	104	2	M10 x 80mm Button Head Bolt
19	2	Knee Pad			"U"-bracket			
20	4	Short Pad	62	1	Double "U"-bracket	105	1	50mm Square Inner Cap
21	5	40mm x 50mm Inner Cap	63	2	Pulley Plate			
22	1	Ab Strap	64	1	"U"-bracket	106	2	M10 x 70mm Carriage Bolt
23	1	Pad Tube	65	3	Adjustment Handle	107	1	M10 x 80mm Bolt
24	1	Base Cap	66	2	Swivel Bushings	108	4	Knee Rest Bumper
25	1	Left Butterfly Arm	67	1	38mm Square Inner Cap	109	2	Knee Pad Cap
26	1	Right Butterfly Arm	68	7	Cable Trap	110	12	M10 x 65mm Carriage Bolt
27	2	Press Handle	69	1	Butterfly Cable			
28	2	Long Handgrip	70	2	Pivot Bracket	111	2	Outer Cap w/Hole
29	2	25mm Round Inner Cap	71	1	Long Frame Plate	112	1	Long Pin w/Tether
30	3	M10 x 165mm Bolt	72	1	Swivel Low Cable	113	1	Large Cable Trap
31	2	Small Pulley Plate	73	1	Squat Cable	114	10	M6 x 16mm Screw
32	1	Squat Arm	74	1	Swivel High Cable	115	1	Adjustment Knob
33	2	Squat Handle	75	1	Leg Lever Cable	116	4	20mm x 40mm Inner Cap
34	8	M8 Nylon Locknut	76	1	Swivel Cage			
35	1	Squat Backrest	77	1	Leg Lever Bumper	117	2	25mm x 40mm Inner Cap
36	4	135mm Handgrip	78	22	90mm Pulley			
37	1	Squat Bracket	79	1	Lat Bar	118	2	M12 Nut
38	1	Squat Slider	80	1	Row Bar	119	4	115mm Pulley
39	4	Roller	81	1	Chain	120	3	M4 Washer
40	8	Roller Bearing	82	1	Handle	121	2	25mm Round Outer Cap
41	1	Squat Knee Rest	83	3	Cable Clip			
42	4	Weight Guide	84	2	200mm Handgrip	#	1	User's Manual
43	2	Weight Tube	85	4	M10 x 70mm Bolt	#	1	Exercise Guide
44	20	Weight	86	1	M10 x 20mm Bolt	#	2	Grease Package
			87	72	M10 Nylon Locknut			

Note: “#” indicates a non-illustrated part. Specifications are subject to change without notice.

# EXPLODED DRAWING—Model No. WESY39523

R0103A

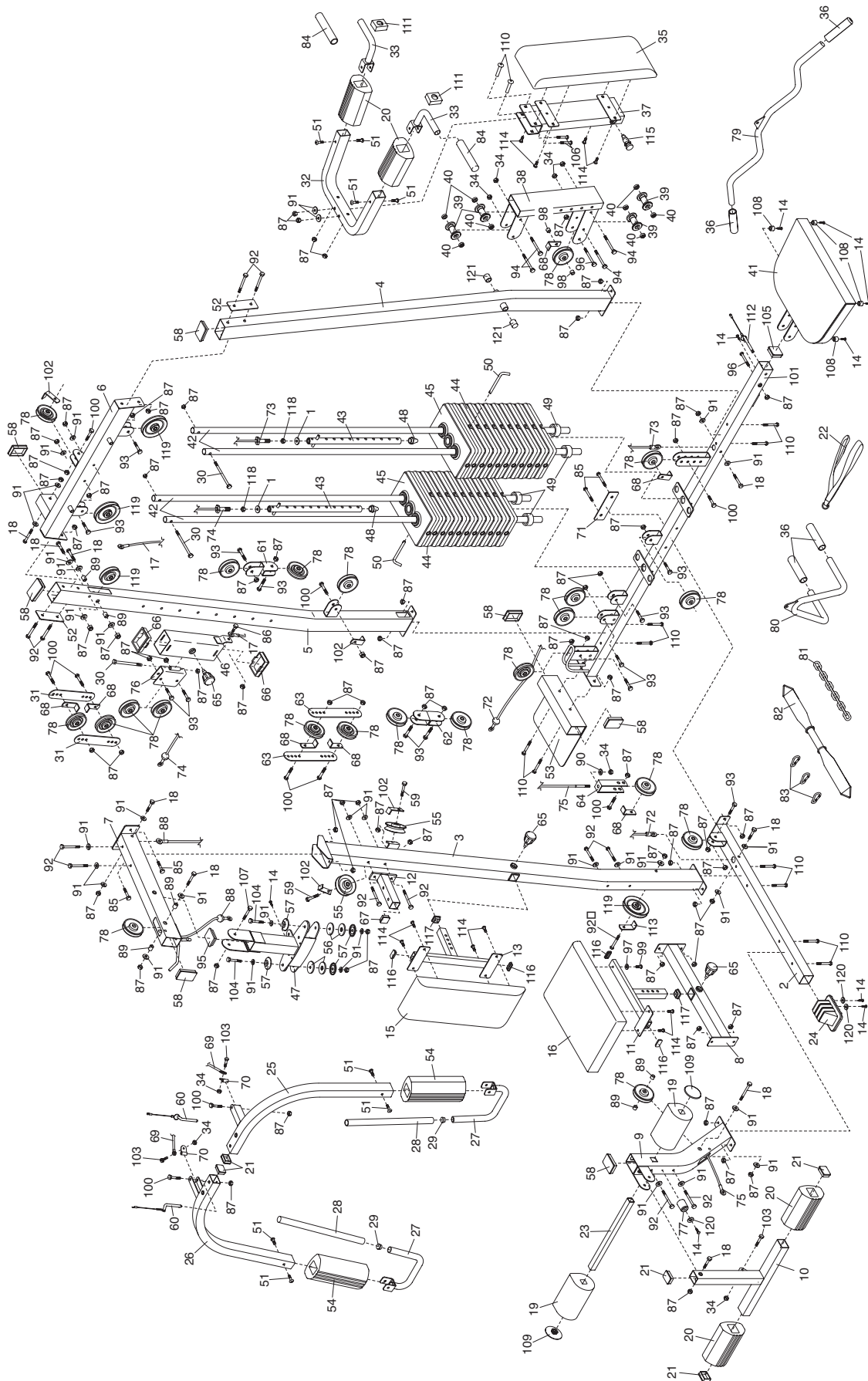

## Free Manuals Download Website

<http://myh66.com>

<http://usermanuals.us>

<http://www.somanuals.com>

<http://www.4manuals.cc>

<http://www.manual-lib.com>

<http://www.404manual.com>

<http://www.luxmanual.com>

<http://aubethermostatmanual.com>

Golf course search by state

<http://golfingnear.com>

Email search by domain

<http://emailbydomain.com>

Auto manuals search

<http://auto.somanuals.com>

TV manuals search

<http://tv.somanuals.com>