

WEIDER® 8630

TRAINING SYSTEM

Model No. WESY86303

Serial No. _____

Write the serial number in the space above for future reference.

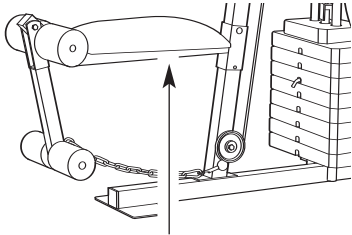

Serial Number Decal (Under Seat)

QUESTIONS?

As a manufacturer, we are committed to providing complete customer satisfaction. If you have questions, or if there are missing or damaged parts, we will guarantee complete satisfaction through direct assistance from our factory.

TO AVOID UNNECESSARY DELAYS, PLEASE CALL DIRECT TO OUR TOLL-FREE CUSTOMER HOT LINE. The trained technicians on our customer hot line will provide immediate assistance, free of charge to you.

CUSTOMER HOT LINE:

1-800-999-3756

Mon.–Fri., 6 a.m.–6 p.m. MST

CAUTION

Read all precautions and instructions in this manual before using this equipment. Save this manual for future reference.

USER'S MANUAL



Patent Pending



Visit our website at

www.weiderfitness.com

*new products, prizes,
fitness tips, and much more!*

TABLE OF CONTENTS

LIMITED WARRANTY	2
IMPORTANT PRECAUTIONS	3
BEFORE YOU BEGIN	4
ASSEMBLY	5
HOW TO USE THE TRAINING SYSTEM	22
WEIGHT RESISTANCE CHART	24
TROUBLE-SHOOTING AND MAINTENANCE	25
CABLE DIAGRAMS	26
ORDERING REPLACEMENT PARTS	Back Cover

Note: A PART IDENTIFICATION CHART and a PART LIST/EXPLODED DRAWING are attached in the center of this manual. Remove the PART IDENTIFICATION CHART and the PART LIST/EXPLODED DRAWING before beginning assembly.

WEIDER is a registered trademark of ICON Health & Fitness, Inc.

LIMITED WARRANTY

ICON Health & Fitness, Inc. (ICON), warrants this product to be free from defects in workmanship and material, under normal use and service conditions, for a period of ninety (90) days from the date of purchase. This warranty extends only to the original purchaser. ICON's obligation under this warranty is limited to replacing or repairing, at ICON's option, the product at one of its authorized service centers. All products for which warranty claim is made must be received by ICON at one of its authorized service centers with all freight and other transportation charges prepaid, accompanied by sufficient proof of purchase. All returns must be pre-authorized by ICON. This warranty does not extend to any product or damage to a product caused by or attributable to freight damage, abuse, misuse, improper or abnormal usage or repairs not provided by an ICON authorized service center, products used for commercial or rental purposes, or products used as store display models. No other warranty beyond that specifically set forth above is authorized by ICON.

ICON is not responsible or liable for indirect, special or consequential damages arising out of or in connection with the use or performance of the product or damages with respect to any economic loss, loss of property, loss of revenues or profits, loss of enjoyment or use, costs of removal, installation or other consequential damages of whatsoever nature. Some states do not allow the exclusion or limitation of incidental or consequential damages. Accordingly, the above limitation may not apply to you.

The warranty extended hereunder is in lieu of any and all other warranties and any implied warranties of merchantability or fitness for a particular purpose is limited in its scope and duration to the terms set forth herein. Some states do not allow limitations on how long an implied warranty lasts. Accordingly, the above limitation may not apply to you.

This warranty gives you specific legal rights. You may also have other rights which vary from state to state.

ICON HEALTH & FITNESS, INC., 1500 S. 1000 W., LOGAN, UT 84321-9813

IMPORTANT PRECAUTIONS

WARNING: To reduce the risk of serious injury, read the following important precautions before using the training system.

1. It is the responsibility of the owner to ensure that all users of the training system are adequately informed of all precautions.
2. Read all instructions in this manual and in the accompanying literature before using the training system.
3. Use the training system only on a level surface. Place a mat beneath the training system to protect the floor or carpet.
4. Inspect and tighten all parts often. Replace any worn parts immediately.
5. Keep children under the age of 12 and pets away from the training system at all times.
6. Never release the press arm, butterfly arms, leg lever, leg press plate, lat bar, ab strap, or nylon strap while weights are raised. The weights will fall with great force.
7. Keep hands and feet away from moving parts.
8. Always wear athletic shoes for foot protection.
9. Always stand on the foot plate when performing an exercise that could cause the training system to tip.
10. When using the leg press station, always be sure that the lock pin is fully inserted and that the lock pin is clipped in place on the adjustment tube (see page 23).
11. Make sure that the cables remain on the pulleys at all times. If the cables bind while you are exercising, stop immediately and make sure that the cables are on all of the pulleys.
12. Always disconnect the lat bar from the training system when performing an exercise that does not use the lat bar.
13. If you feel pain or dizziness at any time while exercising, stop immediately and begin cooling down.
14. The training system is intended for home use only. Do not use the training system in any commercial, rental, or institutional setting.
15. The decal shown at the right has been attached to the training system in the two locations shown on page 4. If a decal is missing or illegible, please call toll-free 1-800-999-3756 to order a free replacement decal. Apply the decal in the location shown.

WARNING

- Misuse of this product may result in serious injury.
- Read user's manual and follow all warnings and operating instructions prior to use.
- Do not allow children on or around machine.
- Replace label if damaged, illegible, or removed.

WARNING: Before beginning this or any exercise program, consult your physician. This is especially important for persons over the age of 35 or persons with pre-existing health problems. Read all instructions before using. ICON assumes no responsibility for personal injury or property damage sustained by or through the use of this product.

BEFORE YOU BEGIN

Thank you for selecting the versatile WEIDER® 8630 training system. The WEIDER® 8630 offers a selection of weight stations designed to develop every major muscle group of the body. Whether your goal is to tone your body, build dramatic muscle size and strength, or improve your cardiovascular system, the WEIDER® 8630 will help you to achieve the specific results you want.

For your benefit, read this manual carefully before using the WEIDER® 8630 training system. If you have additional questions, please call our Customer

Service Department toll-free at 1-800-999-3756, Monday through Friday, 6 a.m. until 6 p.m. Mountain Time (excluding holidays). To help us assist you, please note the product model number and serial number before calling. The model number is WESY86303. The serial number can be found on a decal attached to the WEIDER® 8630 (see the front cover of this manual).

Before reading further, please review the drawing below and familiarize yourself with the parts that are labeled.

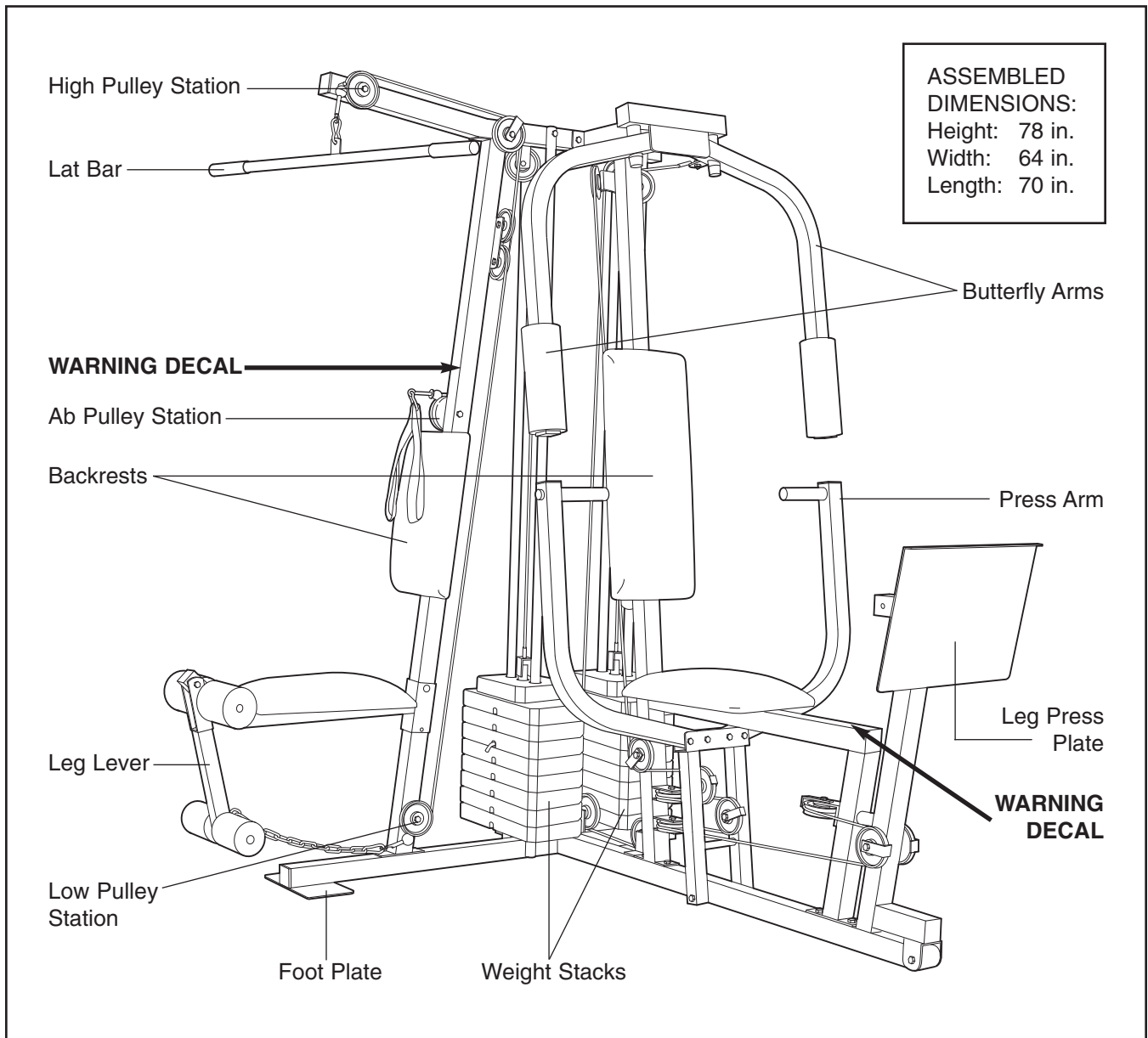

ASSEMBLY

Make Assembly Easier for Yourself!

Everything in this manual is designed to ensure that the training system can be assembled successfully by anyone. **Before beginning assembly, make sure to read the information on this page; this brief introduction will save you much more time than it takes to read it!**

Assembly Requires Two Persons

For your convenience and safety, assemble the training system with the help of another person.

Set Aside Enough Time

Due to the many features of the training system, the assembly process will require about six hours. By setting aside plenty of time and by deciding to make the task enjoyable, assembly will go smoothly. You may want to assemble the training system over a couple of evenings.





Select a Location for the Training System

Because of its weight and size, the training system should be assembled in the location where it will be used. Make sure that there is enough room to walk around the training system as you assemble it.

How to Unpack the Box

To make assembly as easy as possible, we have divided the assembly process into four stages. The parts needed for each stage are found in individual bags. **Important: Wait until you begin each stage to open the parts bag for that stage.** Place all parts of the training system in a cleared area and remove the packing materials. Do not dispose of the packing materials until assembly is completed.

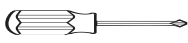
Make sure you have the following tools:

- Two (2) adjustable wrenches 
- One (1) standard screwdriver 
- One (1) phillips screwdriver 
- One (1) rubber mallet 
- You will also need grease or petroleum jelly, a small amount of soapy water, and clear tape or masking tape.

Note: Assembly will be more convenient if you have a socket set, a set of open-end or closed-end wrenches, or a set of ratchet wrenches.

How to Identify Parts

To help you identify the small parts used in assembly, we have included a PART IDENTIFICATION CHART in the center of this manual. Place the chart on the floor and use it to easily identify parts during each assembly step. **Note: Some small parts may have been pre-attached. If a part is not in the parts bag, check to see if it has been pre-attached.**

How to Orient Parts

As you assemble the training system, make sure that all parts are oriented exactly as shown in the drawings.

Tightening Parts

Tighten all parts as you assemble them, unless instructed to do otherwise.

Questions?

If you have questions after reading the assembly instructions, please call our Customer Service Department toll-free at **1-800-999-3756**, Monday through Friday, 6 a.m. until 6 p.m. Mountain Time.

The Four Stages of the Assembly Process

Frame Assembly—You will begin by assembling the base and the uprights that form the skeleton of the training system.

Arm Assembly—During this stage you will assemble the arms and the leg lever.

Cable Assembly—During this stage you will attach the cables and pulleys that connect the arms to the weights.

Seat Assembly—During the final stage you will assemble the seats and the backrests.

1.

Before you begin this step, make sure that you have read all of the information on page 5. This brief introduction will save you much more time than it takes to read it!

Locate and open the parts bags labeled “FRAME ASSEMBLY BAG ONE” and “FRAME ASSEMBLY BAG TWO.”

Press two 2” Square Outer Caps (58) onto the Weight Base (14) in the indicated locations. Press a 2” Square Inner Cap (56) into the end of the Weight Base.

Insert four 5/16” x 2 1/2” Carriage Bolts (49) up through the Press Base (13). Insert two 5/16” x 2 1/2” Carriage Bolts up through the Weight Base (14).

Attach the Press Base (13) to the Weight Base (14) with two 5/16” x 2 3/4” Bolts (55), two 5/16” Washers (20), and two 5/16” Nylon Locknuts (40). **Do not tighten the Nylon Locknuts yet.**

2. Slide the Ab Upright (1) onto the indicated 5/16” x 2 1/2” Carriage Bolts (49) in the Weight Base (14). Hand tighten two 5/16” Nylon Locknuts (40) onto the Carriage Bolts. **Do not tighten the Nylon Locknuts yet.**

Slide the Leg Press Upright (4) onto the indicated 5/16” x 2 1/2” Carriage Bolts (49) in the Weight Base (14). Hand tighten two 5/16” Nylon Locknuts (40) onto the Carriage Bolts. **Do not tighten the Nylon Locknuts yet.**

3. Press a 2” Square Inner Cap (56) into each end of the Top Frame (2). Press a 2” Square Inner Cap (56) into each side of the Butterfly Frame (3). Press two 1” Inner Caps (98) into the top of the Butterfly Frame.

Attach the Butterfly Frame (3) to the Top Frame (2) with a 5/16” x 3” Bolt (92). **Be sure that the Bolt is on the side shown.**

Finish attaching the Butterfly Frame (3) to the Top Frame (2) with a 5/16” Nylon Jam Nut (91), a 5/16” x 2 3/4” Bolt (55), a 5/16” Washer (20), and a 5/16” Nylon Locknut (40).

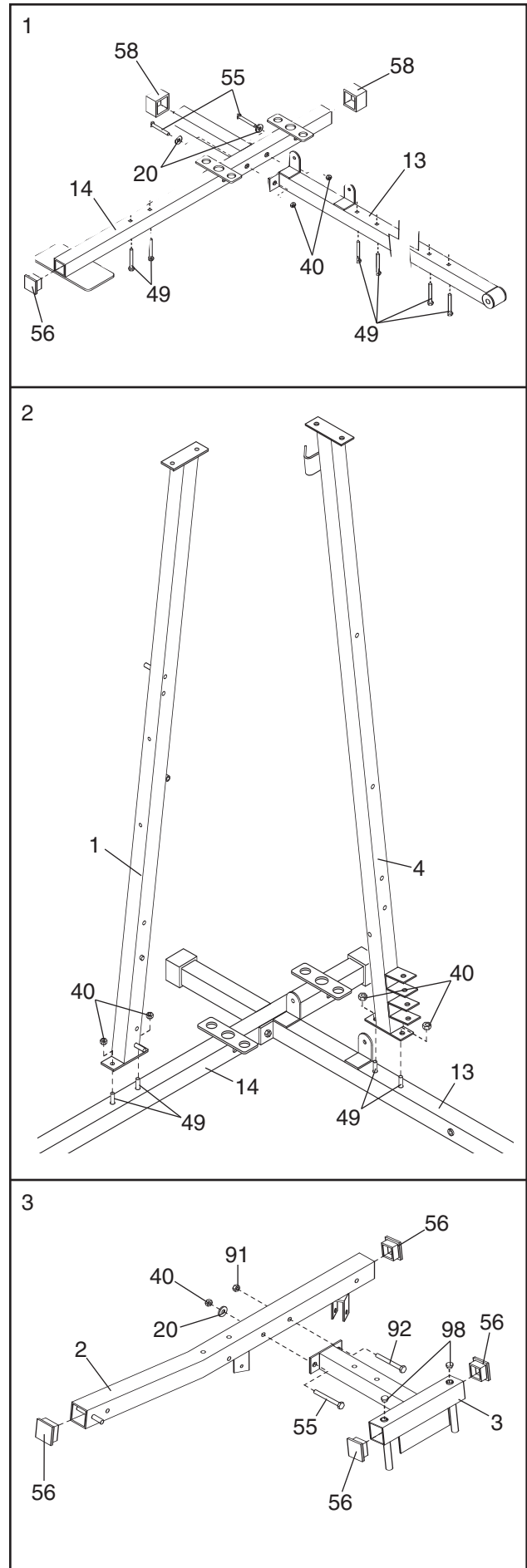

- Slide the Front Seat Frame (8) onto the indicated 5/16" x 2 1/2" Carriage Bolts (49) in the Press Base (13). Hand tighten two 5/16" Nylon Locknuts (40) onto the Carriage Bolts.

Attach the other end of the Front Seat Frame (8) to the Leg Press Upright (4) with two 5/16" x 2 3/4" Bolts (55), two 5/16" Washers (20), and two 5/16" Nylon Locknuts (40).

Press a 2" Square Inner Cap (56) into the Front Seat Frame (8).

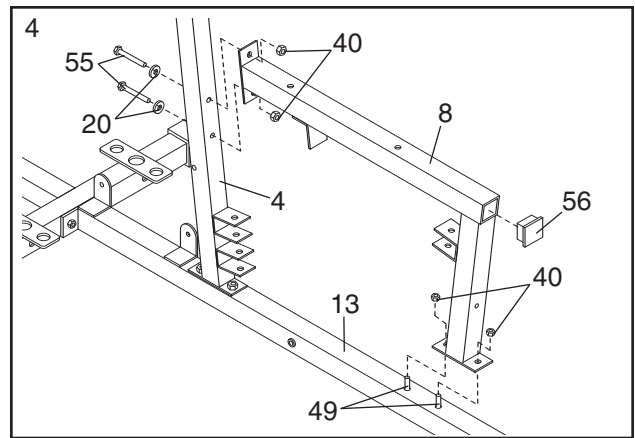

- Insert two Weight Guides (23) into one of the brackets on the Weight Base (14). Attach the lower ends of the Weight Guides with a 5/16" x 6" Bolt (67), two 1/2" x 3/4" Spacers (69), and a 5/16" Nylon Locknut (40). **Do not over-tighten the Nylon Locknut.**

Attach the other Weight Guides (23) in the same manner.

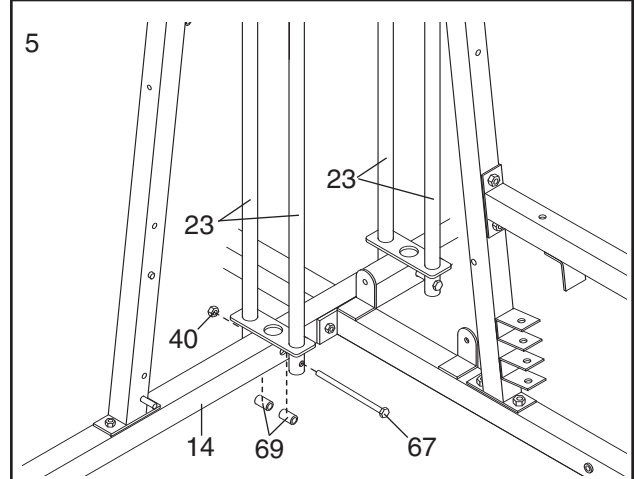

- Slide a Weight Bumper (27) onto each of the Weight Guides (23).

Slide eight Weights (90) onto each set of Weight Guides (23). **Be sure that the pin grooves are on the indicated side of each stack of Weights.**

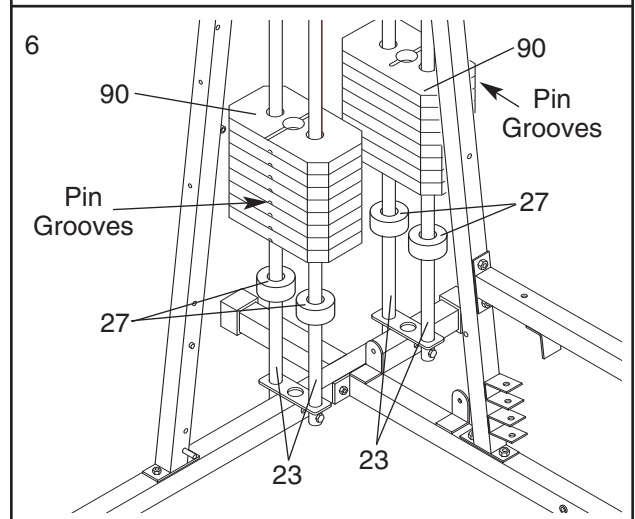

- Press a Weight Tube Bumper (26) into each Weight Tube (25).

Insert a Weight Tube (25) into each stack of Weights (90). **Be sure that the pins on the Weight Tubes are in the pin grooves in the upper Weights.**

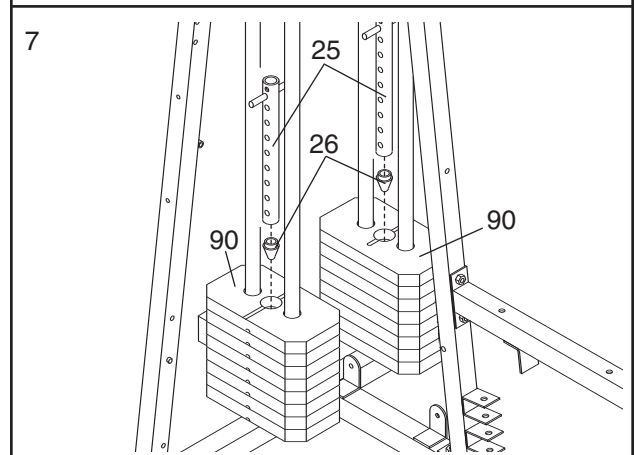

- Lubricate the insides of the holes in the Top Weights (24) as shown. Slide a Top Weight onto each set of Weight Guides (23).

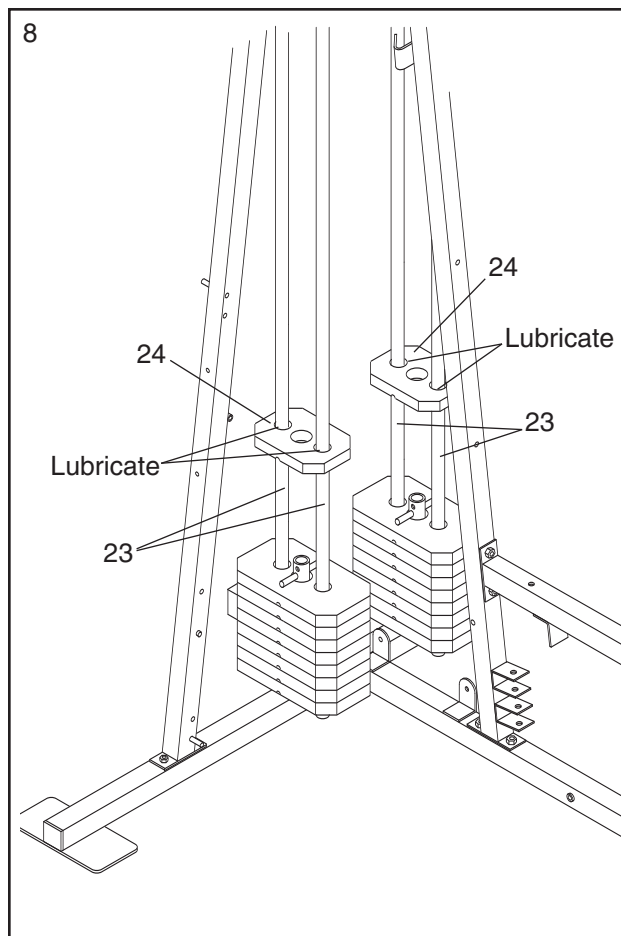

- Attach the Top Frame (2) to the Ab Upright (1) with two 5/16" x 2 3/4" Bolts (55), two 5/16" Washers (20), and two 5/16" Nylon Locknuts (40). **Do not tighten the Nylon Locknuts yet.**

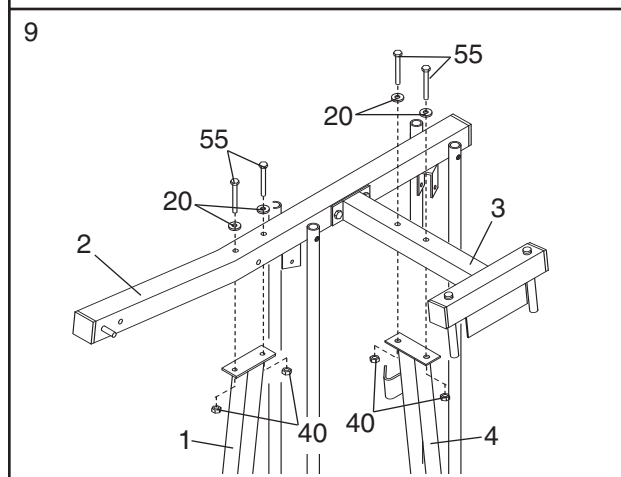

Attach the Butterfly Frame (3) to the Leg Press Upright (4) with two 5/16" x 2 3/4" Bolts (55), two 5/16" Washers (20), and two 5/16" Nylon Locknuts (40). **Do not tighten the Nylon Locknuts yet.**

- Attach the upper ends of one set of Weight Guides (23) to the Top Frame (2) with a 5/16" x 6" Bolt (67), two 1/2" x 3/4" Spacers (69), and a 5/16" Nylon Locknut (40).

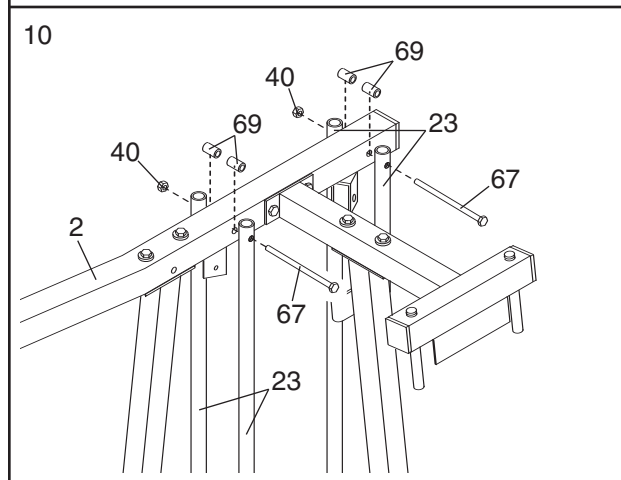

Attach the upper ends of the other set of Weight Guides (23) in the same manner.

Before continuing, firmly tighten all nylon locknuts used in steps 1 through 10.

11. Attach the Leg Press Plate (11) to the Adjustment Tube (10) with a 5/16" x 2 1/2" Bolt (39), two 5/16" Washers (20), and a 5/16" Nylon Locknut (40). **Be sure that the Leg Press Plate and Adjustment Tube are oriented as shown.**

Press a 1 3/4" Square Inner Cap (48) into the Adjustment Tube (10).

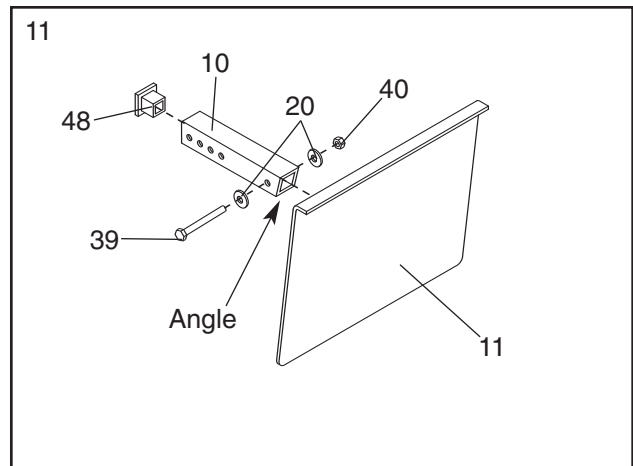

12. Attach the Adjustment Tube (10) to the Leg Press Arm (9) with the Lock Pin (73). **Be sure the Leg Press Plate (11) is oriented as shown.**

Press two 2" Square Inner Caps (56) into the Leg Press Arm (9).

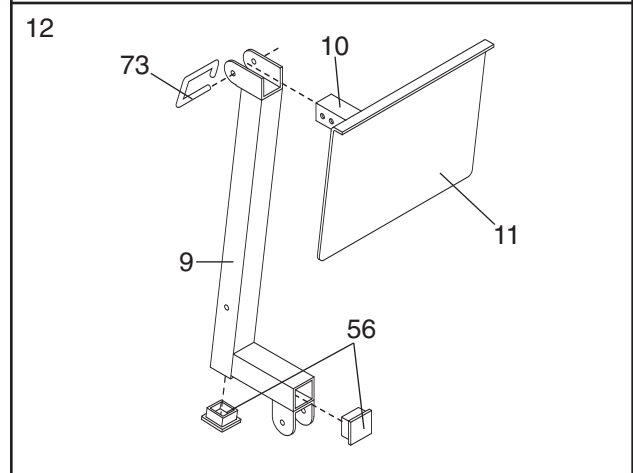

13. **Locate and open the parts bag labeled "ARM ASSEMBLY."**

Attach the Leg Press Bumper (53) to the Front Seat Frame (8) with the 1" Tap Screw (72).

Lubricate the 3/8" x 3 1/4" Bolt (71). Attach the Leg Press Arm (9) to the Press Base (13) with the Bolt and a 3/8" Nylon Locknut (42).

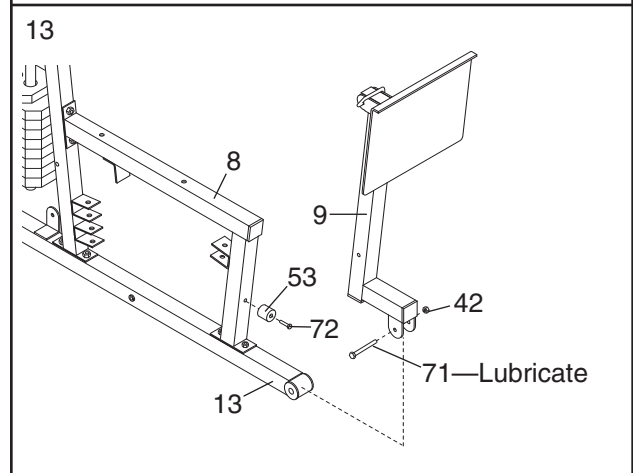

14. Press a 1" x 7/8" Plastic Bushing (54) onto each welded spacer on the Press Frame (12). Slide the Press Frame onto the Press Base (13) so that the Plastic Bushings are aligned with the indicated tube. **Note: This will be a tight fit. Make sure that the high pulley is on the side shown.**

Lubricate the 3/8" x 8" Bolt (52). Attach the Press Frame (12) to the Press Base (13) with the Bolt and a 3/8" Nylon Locknut (42).

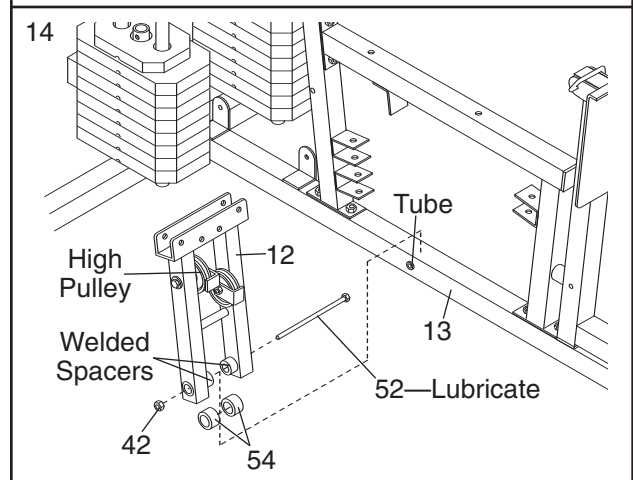

15. Attach a Press Arm (7) to one side of the Press Frame (12) with two 5/16" x 2 1/2" Bolts (39) and two 5/16" Nylon Locknuts (40).

Attach the other Press Arm (7) to the Press Frame (12) in the same manner.

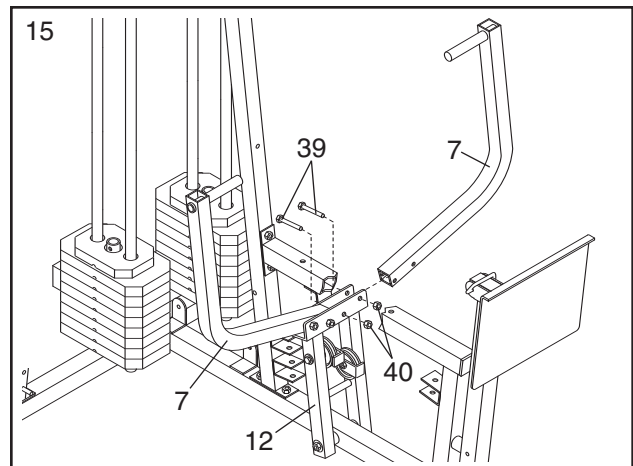

16. Press a 1" Round Inner Cap (70) into one of the Press Arms (7). Press a 1 3/4" Square Inner Cap (48) into the Press Arm.

Repeat this step for the other Press Arm (not shown).

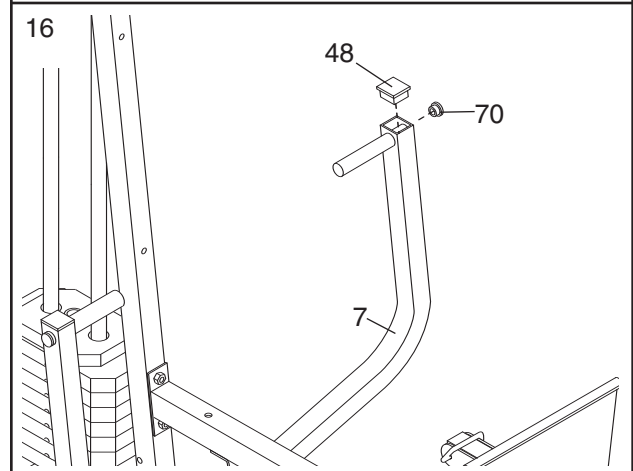

17. Lubricate both axles on the Butterfly Frame (3).

Refer to the drawing and identify the Right Fly Arm (5) and the Left Fly Arm (6).

Press a 1 3/4" Square Inner Cap (48) into the upper end of the Left Arm (6). Slide the Left Fly Arm onto the indicated axle. **Note: Be careful not to confuse the Left Arm with the Right Arm (5). Be sure that the upper end of the Left Arm is behind the indicated bracket on the Butterfly Frame (3).**

IMPORTANT NOTE: Before assembling the 1" Retainers (45) used in this step, be sure that you thoroughly understand the step. The Retainers can be assembled only once. If they must be removed, you will need to order new Retainers.

Tap two 1" Retainers (45) and a 1" Round Outer Cap (46) onto the axle. **Be sure that the teeth on the Retainers bend toward the Round Outer Cap, as shown in the inset drawing.**

Attach the Right Fly Arm (5) in the same manner.

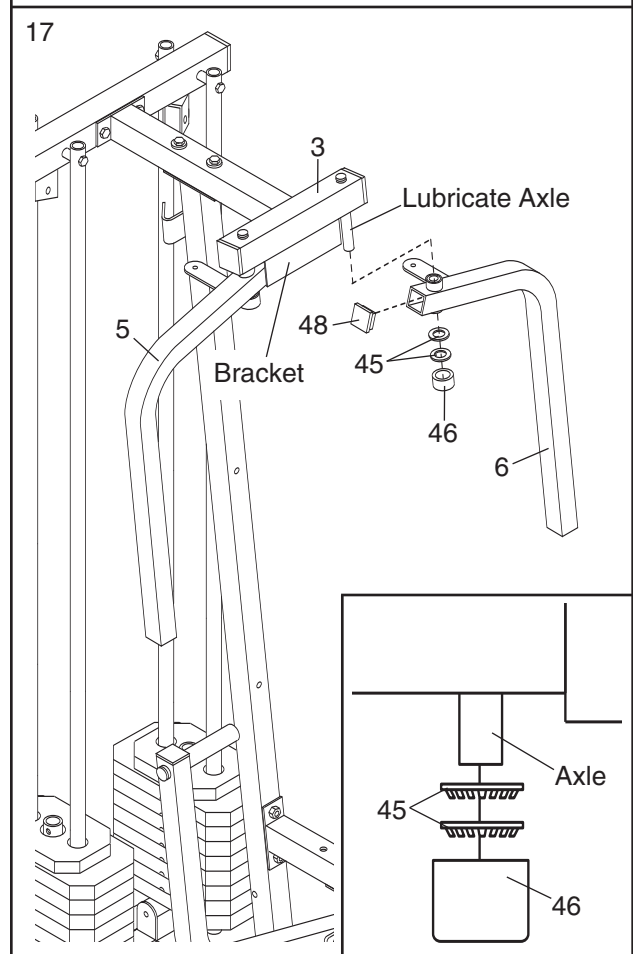

18. Press a 1 3/4" Square Inner Cap (48) into the lower end of the Left Fly Arm (6). Wet the lower end of the Left Fly Arm with soapy water. Slide a 10" Pad (22) onto the Left Arm.

Repeat this step with the Right Fly Arm (5).

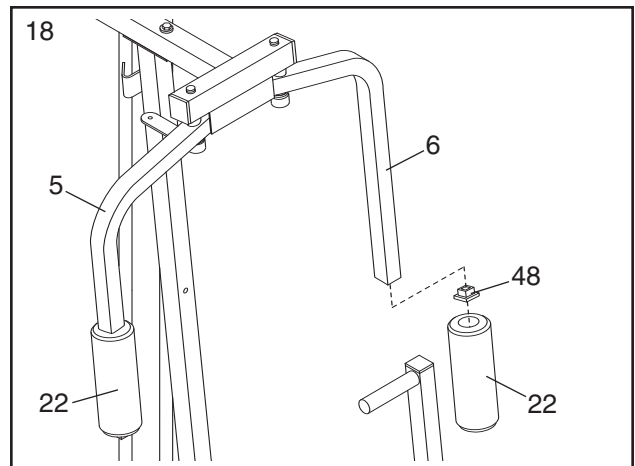

19. **Locate and open the parts bags labeled "CABLE ASSEMBLY" and "PULLEYS."**

During steps 19 through 50, refer to the CABLE DIAGRAMS on pages 26 and 27 of this manual to verify proper cable routing. Before beginning this section, fully unwind the five Cables and identify the Cables by comparing the lengths and the ends. The approximate length of each Cable, in inches, is listed after the key number in the drawing.

IMPORTANT: While assembling the cables, do not overtighten the bolts and nuts attaching the pulleys. The pulleys must be able to turn freely.

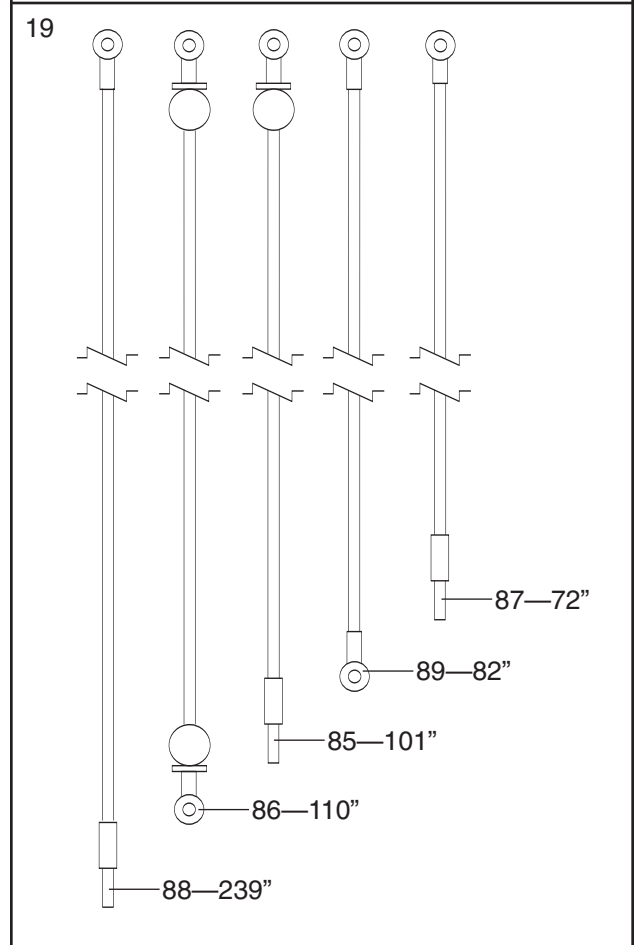

20. Insert a 5/16" x 1" Bolt (51) through the bracket on the Right Fly Arm (5). Tighten a 5/16" Nylon Jam Nut (91) onto the Bolt.

Identify the Butterfly Cable (89)—this is the second shortest Cable. Slide one end of the Butterfly Cable onto the 5/16" x 1" Bolt (51). Thread another 5/16" Nylon Jam Nut (91) onto the Bolt, **but do not fully tighten it.** Leave enough room between the two Jam Nuts for the Cable to pivot.

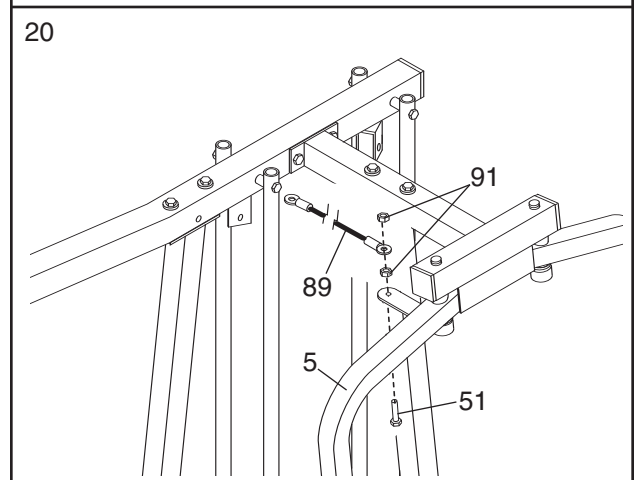

21. Wrap the Butterfly Cable (89) around a 3 1/2" Pulley (82) as shown. Attach the Pulley and a Cable Trap (80) to the bracket on the Leg Press Upright (4) with a 3/8" x 2" Bolt (50) and a 3/8" Nylon Locknut (42). **The Cable Trap must be oriented as shown and be positioned to hold the Cable in the groove of the Pulley.**

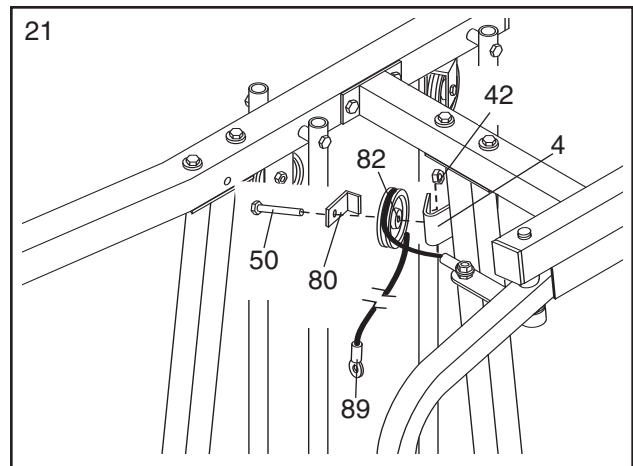

22. **Locate one of the preassembled pairs of Pulley Plates (31) and 3 1/2" Pulleys (82).**

Route the Butterfly Cable (89) under the indicated 3 1/2" Pulley (82). The end of the Pulley Plates (31) with two holes should be downward. Refer to the inset drawing. **Be sure that the Cable is between the Cable Trap (80) and the Pulley, and that the Cable Trap is positioned to hold the Cable in place.**

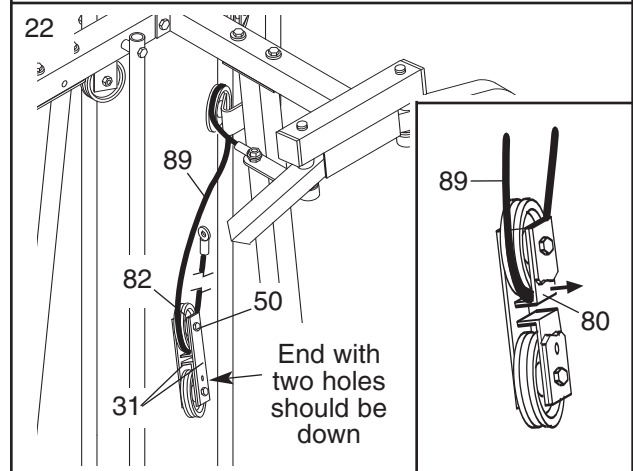

Tighten the 3/8" x 2" Bolt (50) and the 3/8" Nylon Locknut (not shown).

23. Wrap the Butterfly Cable (89) around a 3 1/2" Pulley (82) as shown. Attach the Pulley and a Cable Trap (80) to the other side of the bracket on the Leg Press Upright (4) with a 3/8" x 2" Bolt (50) and a 3/8" Nylon Locknut (42). **The Cable Trap must be oriented as shown and be positioned to hold the Cable in the groove of the Pulley.**

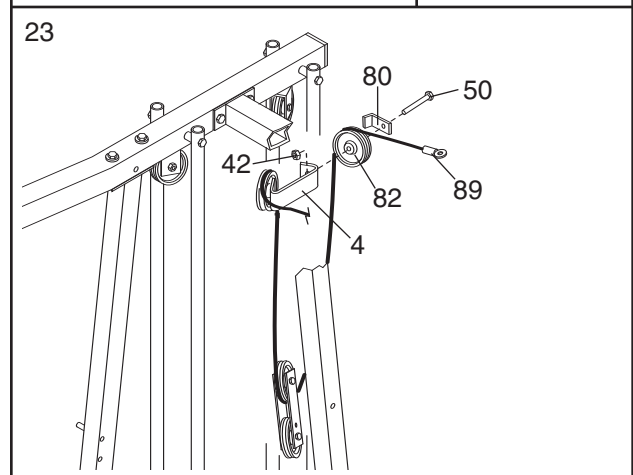

24. **Note: The Left Fly Arm (6) is shown removed for easier part identification.** Insert a 5/16" x 1" Bolt (51) through the bracket on the Left Fly Arm. Fully tighten a 5/16" Nylon Jam Nut (91) onto the Bolt.

Slide the free end of the Butterfly Cable (89) onto the 5/16" x 1" Bolt (51). Thread another 5/16" Nylon Jam Nut (91) onto the Bolt, **but do not fully tighten it. Leave enough room between the two Jam Nuts for the Cable to pivot.**

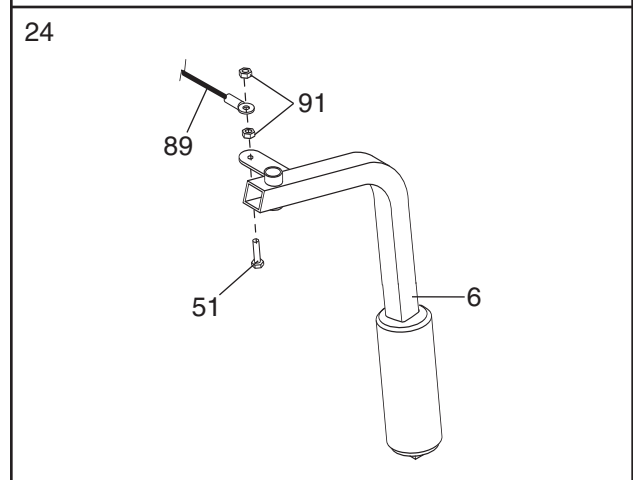

25. **Identify the Rear Cable (87)—this is the shortest Cable.** Slide one end of the Rear Cable onto the 5/16" x 3" Bolt (92). Thread another 5/16" Nylon Jam Nut (91) onto the Bolt, **but do not fully tighten it. Leave enough room between the two Jam Nuts for the Cable to pivot.**

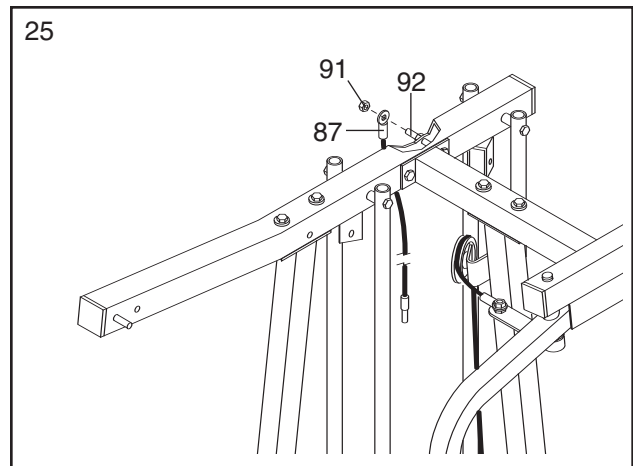

26. See the inset drawing. Attach a 3 1/2" Pulley (82) and a Cable Trap (80) to the upper hole in a Large "U" Bracket (84) with a 3/8" x 2" Bolt (50) and a 3/8" Nylon Locknut (42). **Be sure that the Cable Trap is inside the Large "U" Bracket. Note: This may come pre-assembled.**

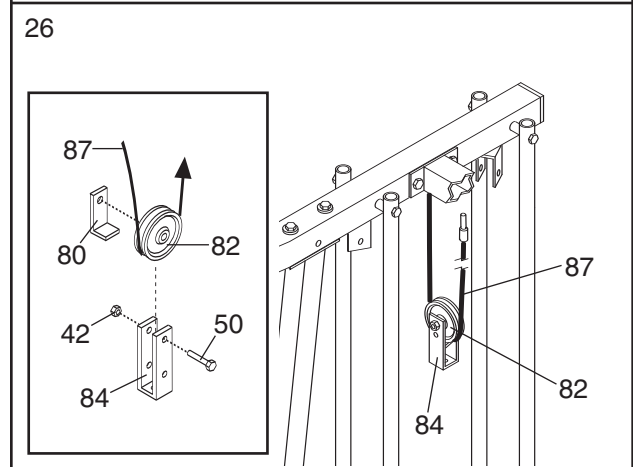

Route the Rear Cable (87) through the Large "U" Bracket (84) and the 3 1/2" Pulley (82). **Be sure that the Cable is in the groove of the Pulley and that the Cable and Pulley move smoothly.**

27. Wrap the Rear Cable (87) around a 3 1/2" Pulley (82). Attach the Pulley to the Top Frame (2) with a 3/8" x 2" Bolt (50) and a 3/8" Nylon Locknut (42). **The Cable must be routed from the direction shown.**

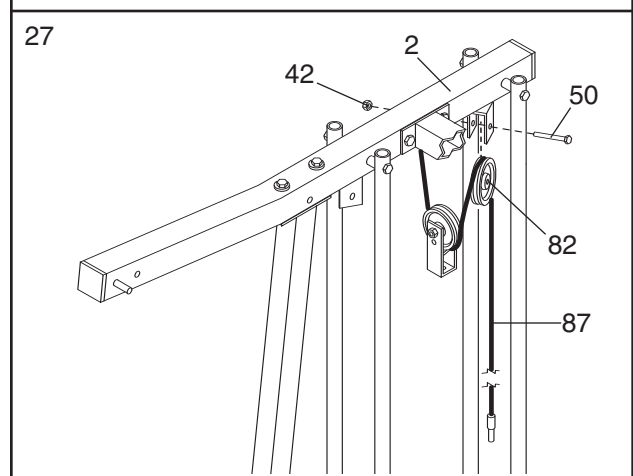

28. Attach the Rear Cable (87) to a Small "U" Bracket (32) with a 1/4" Nylon Locknut (44) and a 1/4" Washer (37). **Do not completely tighten the Nylon Locknut. It should be threaded onto the end of the Cable only a couple of turns, as shown in the inset drawing.**

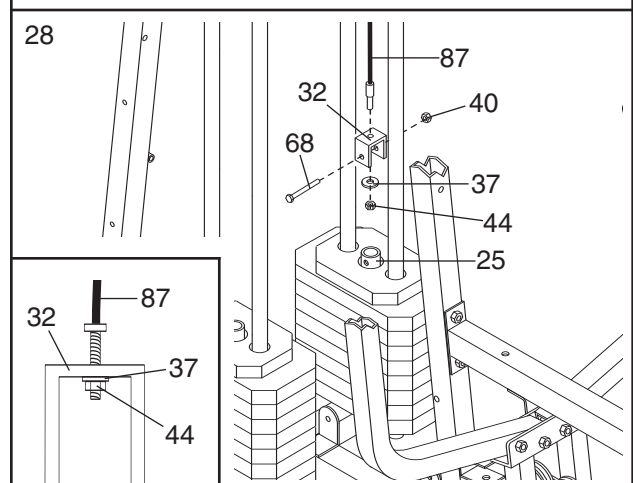

Attach the Small "U" Bracket (32) to the indicated Weight Tube (25) with a 5/16" x 1 3/4" Bolt (68) and a 5/16" Nylon Locknut (40).

29. **Identify the Press Cable (88)—this is the longest Cable.** Attach the end of the Press Cable (88) to the Large “U” Bracket (84) with a 1/4” Nylon Locknut (44) and a 1/4” Washer (37). **Do not completely tighten the Nylon Locknut. It should be threaded onto the end of the Cable so only a couple of threads are showing above the Nylon Locknut, as shown in the inset drawing.**

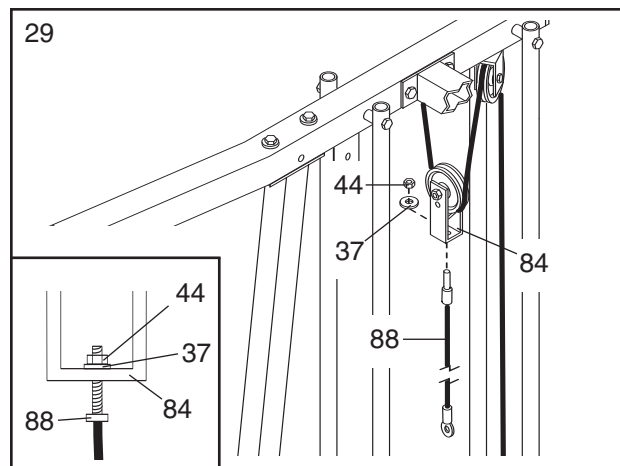

30. Wrap the Press Cable (88) around a 3 1/2” Pulley (82). Attach the Pulley and a Cable Trap (80) to the indicated bracket on the Press Base (13) with a 3/8” x 2” Bolt (50) and a 3/8” Nylon Locknut (42). **Be sure that the Cable Trap is turned to hold the Cable in place.**

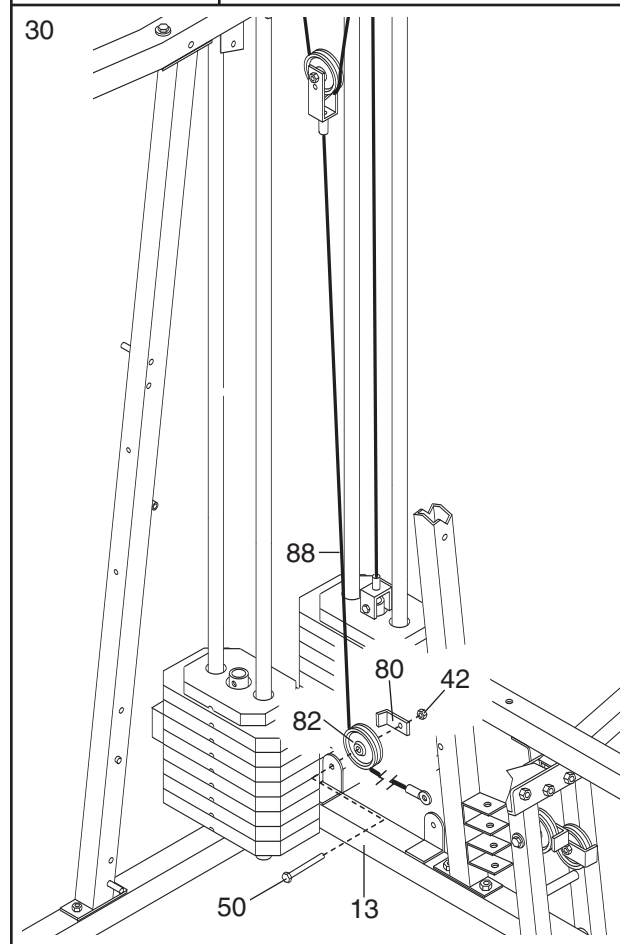

31. Wrap the Press Cable (88) around a 3 1/2” Pulley (82). Attach the Pulley and a Cable Trap (80) to the other bracket on the Press Base (13) with a 3/8” x 2” Bolt (50) and a 3/8” Nylon Locknut (42). **Be sure that the Cable Trap is turned to hold the Cable in place.**

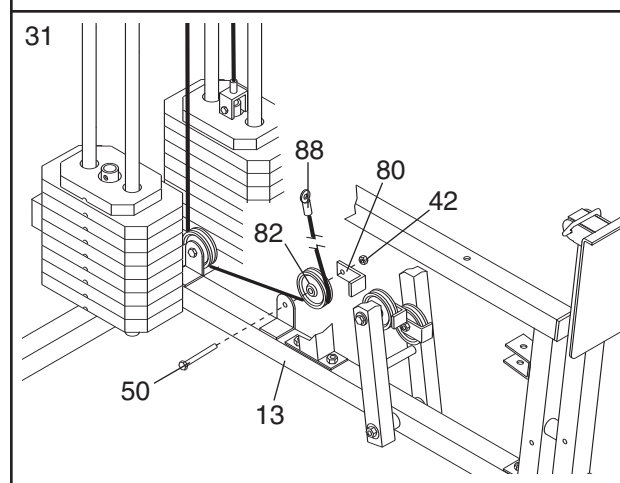

32. Route the Press Cable (88) over the indicated 3 1/2" Pulley (82) attached to the Pulley Plates (31). **The Cable must be routed from the direction shown.** Refer to the inset drawing. **Be sure that the Cable is between the Cable Trap (80) and the Pulley, and that the Cable Trap is positioned to hold the Cable in place.**

Tighten the 3/8" x 2" Bolt (50) and the 3/8" Nylon Locknut (not shown).

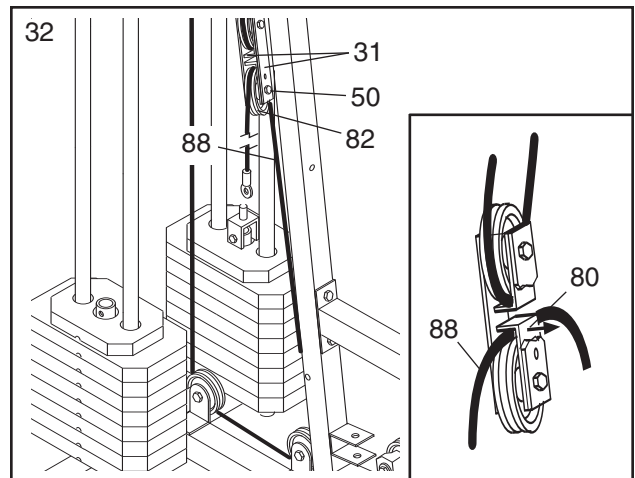

33. Route the Press Cable (88) around a 3 1/2" Pulley (82). Attach the Pulley and a Cable Trap (80) to the Leg Press Upright (4) with a 3/8" x 3 3/4" Bolt (76), a 3/8" Washer (38) and a 3/8" Nylon Jam Nut (43). **Be sure that the Cable Trap is turned to hold the Cable in place.**

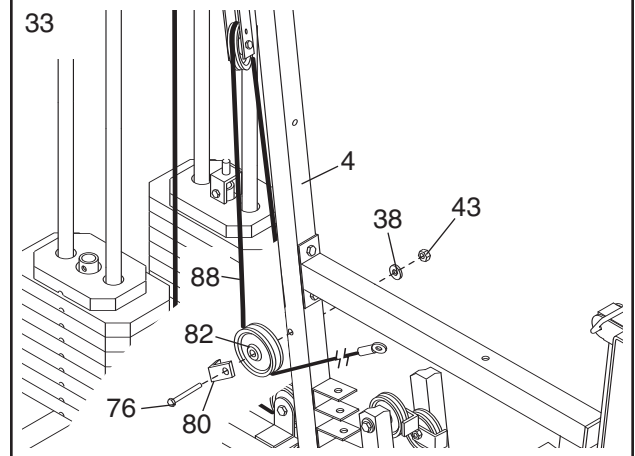

34. Route the Press Cable (88) over the indicated 3 1/2" Pulley (82) attached to the Press Frame (12). Tighten the 3/8" x 3 1/2" Bolt (66) and the 3/8" Nylon Locknut (not shown).

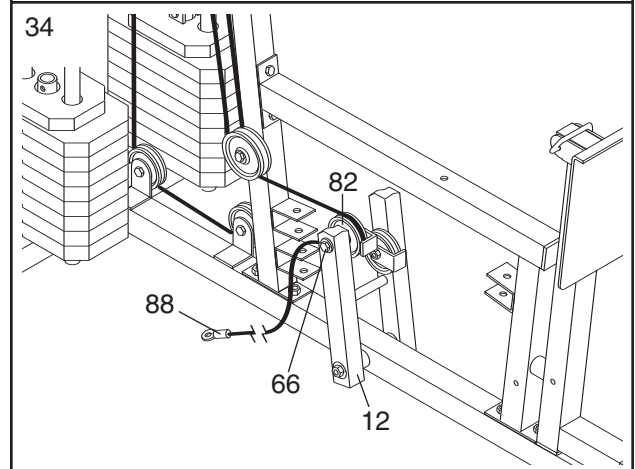

35. Wrap the Press Cable (88) around a "V" Pulley (81). Attach the "V" Pulley to the upper bracket on the Leg Press Upright (4) with a 3/8" x 2 1/4" Bolt (97) and a 3/8" Nylon Jam Nut (43).

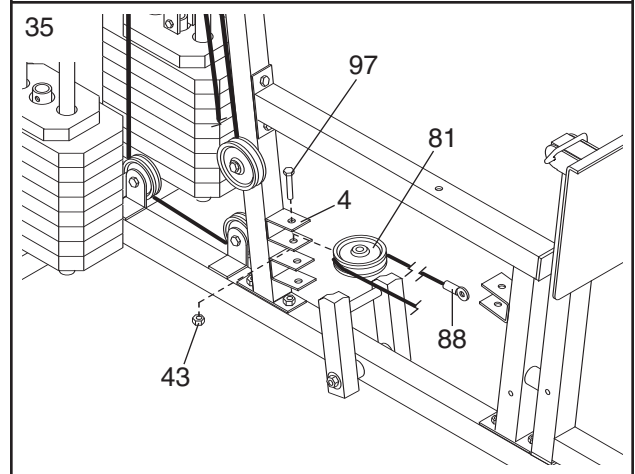

36. Route the Press Cable (88) over the indicated 3 1/2" Pulley (82) attached to the Press Frame (12). **Be sure that the Cable Trap (80) is turned to hold the Cable in place and that the Cable is between the Pulley and the crossbar on the Press Frame.** Tighten the 3/8" Nylon Locknut (42) and the 3/8" x 3 1/2" Bolt (not shown).

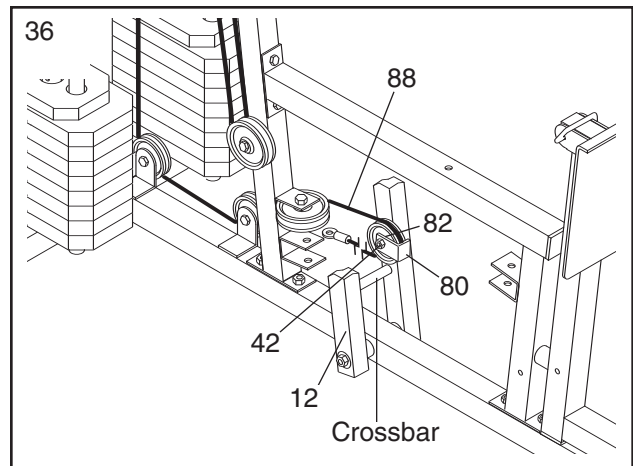

37. Wrap the Press Cable (88) around a "V" Pulley (81). Attach the "V" Pulley to the lower bracket on the Leg Press Upright (4) with a 3/8" x 2 1/4" Bolt (97) and a 3/8" Nylon Jam Nut (43).

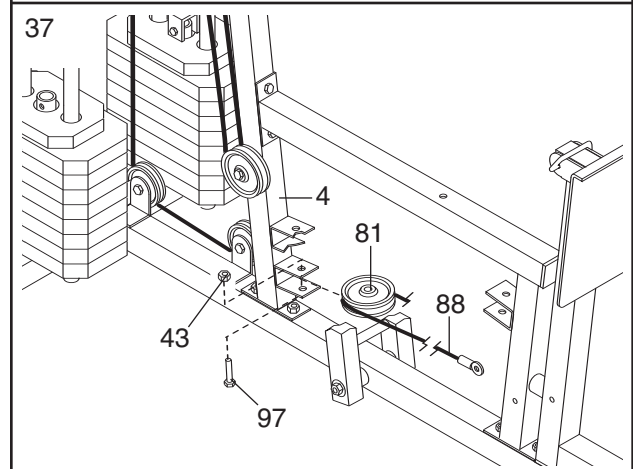

38. Wrap the Press Cable (88) around a 3 1/2" Pulley (82). Attach the Pulley and a Cable Trap (80) to the Leg Press Arm (9) with the 3/8" x 5" Bolt (74).

Slide another 3 1/2" Pulley (82) with a Cable Trap (80) onto the 3/8" x 5" Bolt (74). Hand tighten a 3/8" Nylon Locknut (42) onto the Bolt. **Do not tighten the Nylon Locknut until step 40.**

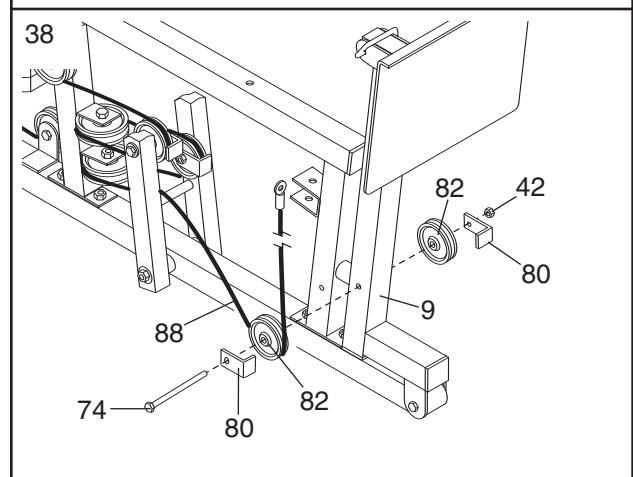

39. Wrap the Press Cable (88) around a "V" Pulley (81). Attach the "V" Pulley and a Large Cable Trap (83) to the bracket on the Front Seat Frame (8) with a 3/8" x 2 1/2" Bolt (65) and a 3/8" Nylon Locknut (42). **Be sure that the Large Cable Trap is turned to hold the Cable in place and that the Cable and Pulley move smoothly.**

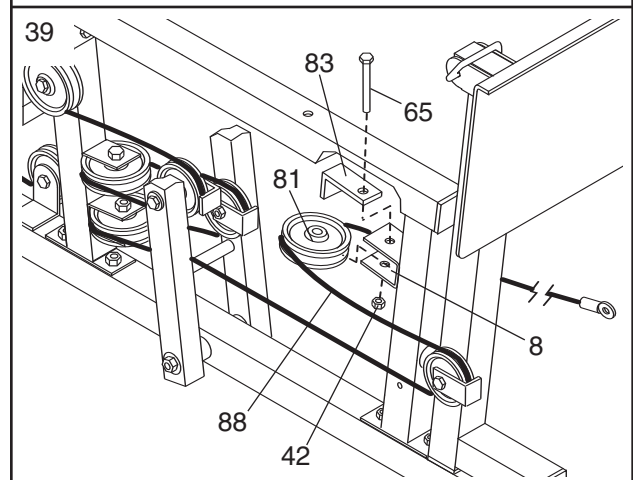

40. **Note: The 3 1/2" Pulley (82) used in this step was attached in step 38. It is shown removed for easier part identification.**

Route the Press Cable (88) around the 3 1/2" Pulley (82). **Be sure that the Cable Trap (80) is turned to hold the Cable in place and that the Cable is routed as shown.** Tighten the 3/8" x 5" Bolt (74) and the 3/8" Nylon Locknut (42).

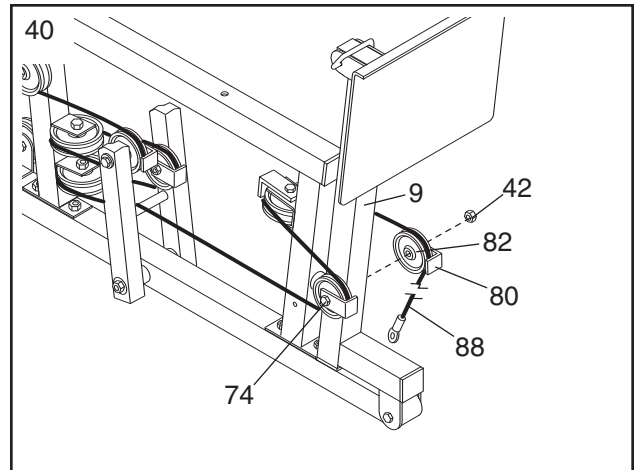

41. Slide a 5/16" Washer (20) onto a 5/16" x 2 3/4" Bolt (55). Insert the Bolt into the Front Seat Frame (8). Fully tighten a 5/16" Nylon Jam Nut (91) onto the Bolt. Slide the end of the Press Cable (88) onto the Bolt. Thread another 5/16" Nylon Jam Nut onto the Bolt, **but do not fully tighten it. Leave enough room between the two Jam Nuts for the Cable to pivot.**

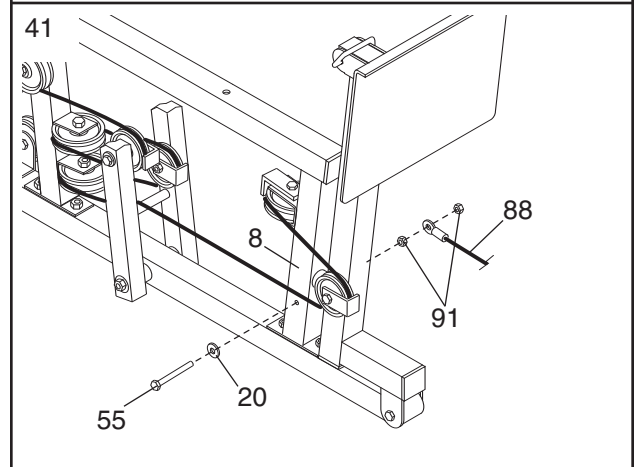

42. **Identify the High Cable (85)—this is the shortest remaining cable.** Wrap the High Cable around a 3 1/2" Pulley (82). Attach the Pulley to the Top Frame (2) with a 3/8" x 3 3/4" Bolt (76), a 3/8" Washer (38), and a 3/8" Nylon Locknut (42). **Be sure that the end of the Cable with the ball is on the indicated side of the Pulley and that the Cable is between the Pulley and the post.**

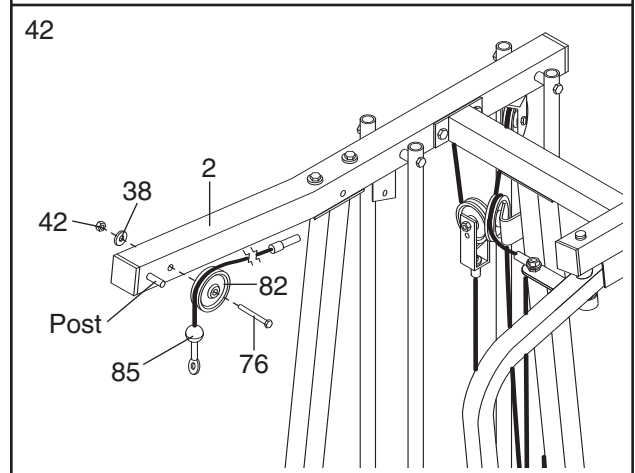

43. Wrap the High Cable (85) around a 3 1/2" Pulley (82). Attach the Pulley and a Cable Trap (80) to the Top Frame (2) with a 3/8" x 3 3/4" Bolt (76), a 3/8" Washer (38), and a 3/8" Nylon Jam Nut (43). **Be sure that the Cable Trap is positioned to hold the Cable in place.**

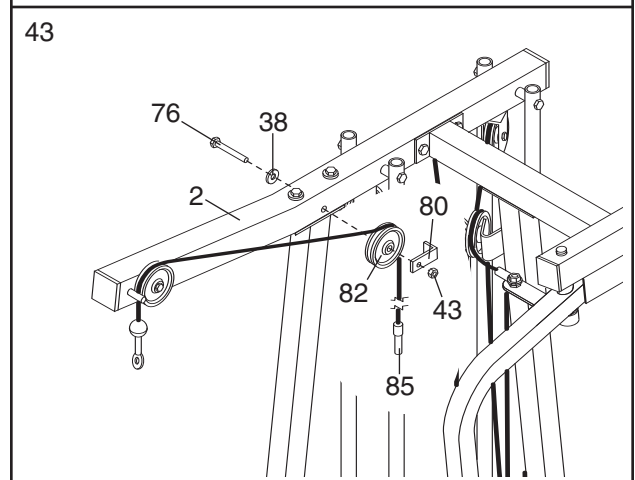

44. Locate the remaining preassembled pair of Pulley Plates (31) and 3 1/2" Pulleys (82).

Route the High Cable (85) under the indicated 3 1/2" Pulley (82). The end of the Pulley Plates (31) with two holes should be downward. Refer to the inset drawing. **Be sure that the Cable is between the Cable Trap (80) and the Pulley, and that the Cable Trap is positioned to hold the Cable in place.**

Tighten the 3/8" x 2" Bolt (50) and the 3/8" Nylon Locknut (not shown).

45. Wrap the High Cable (85) around a 3 1/2" Pulley (82). Attach the Pulley to the Top Frame (2) with a 3/8" x 2" Bolt (50) and a 3/8" Nylon Locknut (42). **The Cable must be routed from the direction shown.**

46. Attach the High Cable (85) to a Small "U" Bracket (32) with a 1/4" Nylon Locknut (44) and a 1/4" Washer (37). **Do not completely tighten the Nylon Locknut. It should be threaded onto the end of the Cable only a couple of turns, as shown in the inset drawing.**

Attach the Small "U" Bracket (32) to the indicated Weight Tube (25) with a 5/16" x 1 3/4" Bolt (68) and a 5/16" Nylon Locknut (40).

47. Lay the Low Cable (86) over a 3 1/2" Pulley (82). Attach the Pulley and both Pulley Covers (94) to the Ab Upright (1) with the 3/8" x 4" Bolt (95), two 3/8" Washers (38), and a 3/8" Nylon Locknut (42). **Do not overtighten the Nylon Locknut; the Pulley should turn easily. Make sure that the Cable is between the Pulley and the post, and that the Pulley Covers are turned so the wide tabs are on the indicated side.**

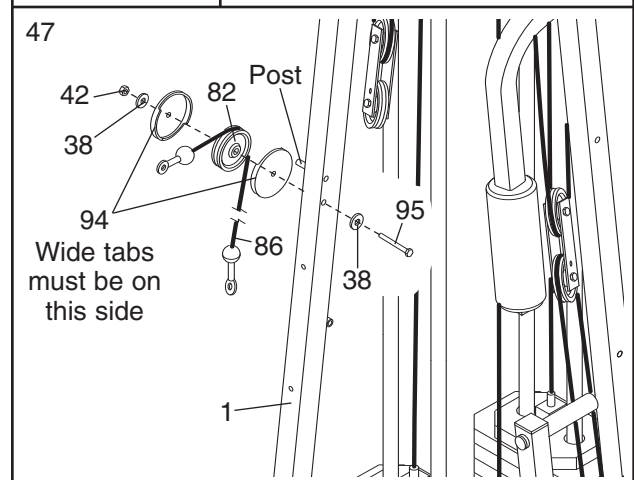
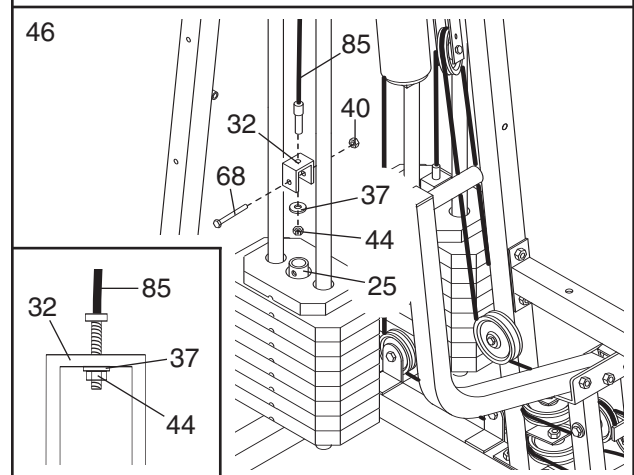
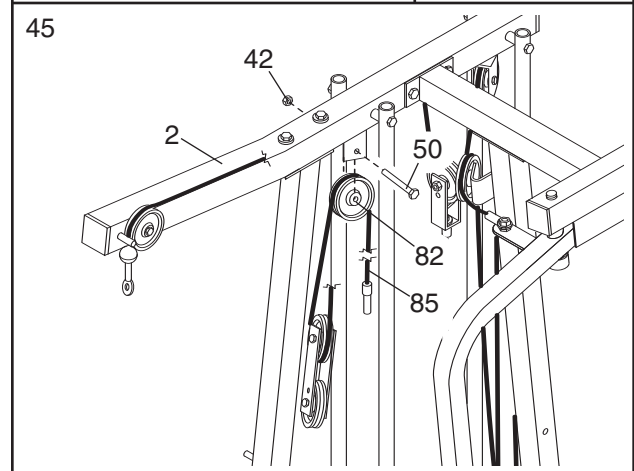
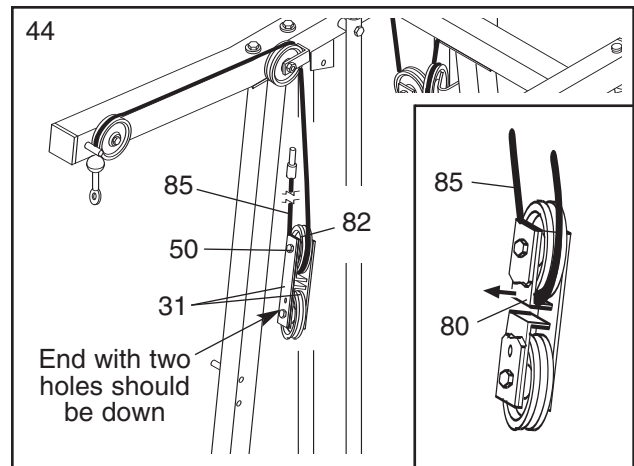

48. Wrap the Low Cable (86) around a 3 1/2" Pulley (82). Attach the Pulley and a Cable Trap (80) to the Ab Upright (1) with the 3/8" x 3 3/4" Bolt (76) and a 3/8" Nylon Locknut (42). **Be sure that the Cable Trap is in the indicated position.**

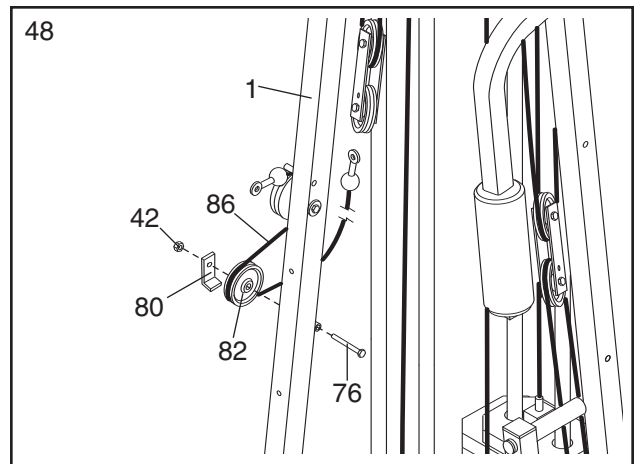

49. Remove the indicated 3/8" x 2" Bolt (50), the 3/8" Nylon Locknut (42), the 3 1/2" Pulley (82), and the Cable Trap (80) from the indicated Pulley Plates (31). Lay the Low Cable (86) over the Pulley. Reattach the Pulley and the Cable Trap to the **lowest** hole in the Pulley Plates with the Bolt and the Nylon Locknut. **Make sure that the Cable Trap is turned to hold the Cable in place.**

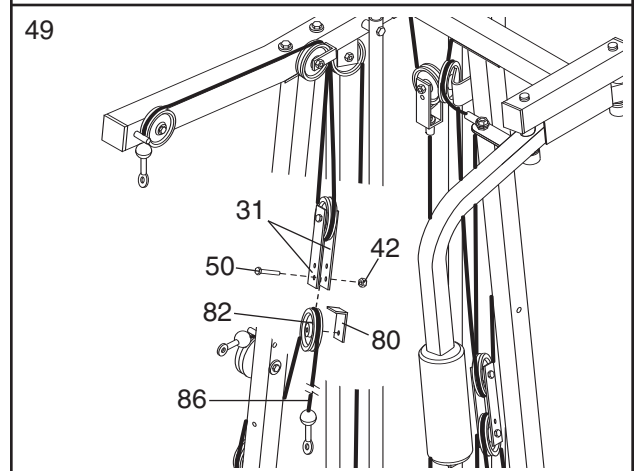

50. Wrap the Low Cable (86) around a 3 1/2" Pulley (82). Attach the Pulley to the Ab Upright (1) with the 3/8" x 3 3/4" Bolt (76), a 3/8" Washer (38), and a 3/8" Nylon Locknut (42). **The ball on the Cable must be on the indicated side of the Pulley. Be sure that the Cable and Pulley move smoothly and that the Cable is between the Pulley and the post.**

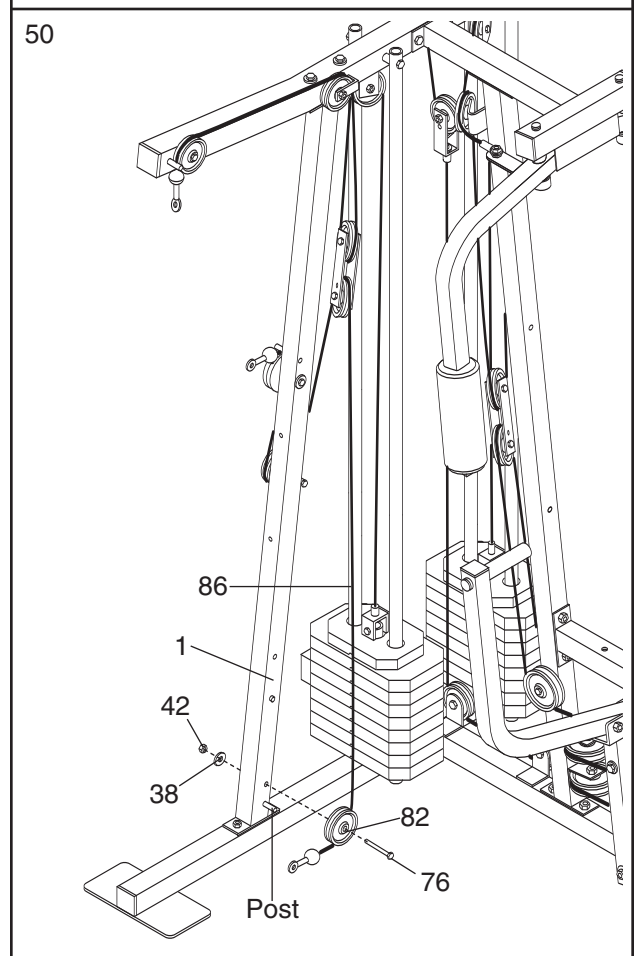

51. **Locate and open the parts bag labeled "SEAT ASSEMBLY."**

Attach the Small Backrest (18) to the Ab Upright (1) with two 1/4" x 2 1/2" Machine Screws (64) and two 1/4" Washers (37).

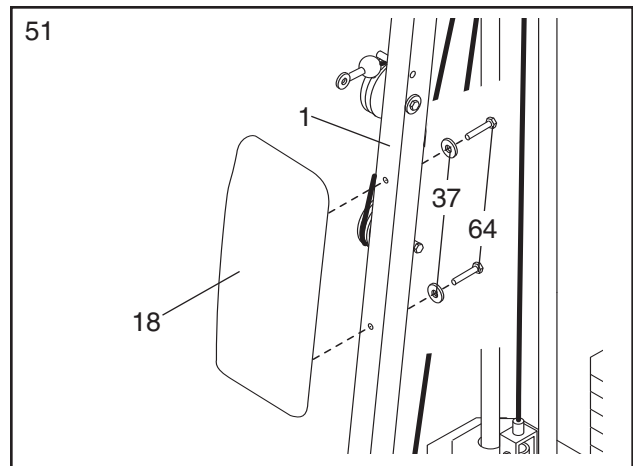

52. Press a 1 1/2" Square Inner Cap (57) into the Rear Seat Frame (16).

Insert a 1/4" x 2" Carriage Bolt (61) through the center hole in a Seat Plate (41). Attach the Seat Plate to the Seat (17) with two 1/4" x 3/4" Screws (59).

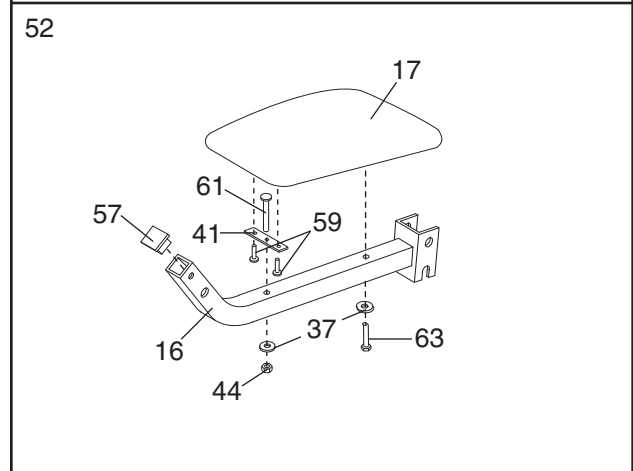

Insert the 1/4" x 2" Carriage Bolt (61) through the indicated hole in the Rear Seat Frame (16). Tighten a 1/4" Nylon Locknut (44) with a 1/4" Washer (37) onto the Carriage Bolt.

Attach the other end of the Seat (17) to the Rear Seat Frame (16) with a 1/4" Washer (37) and a 1/4" x 2" Machine Screw (63).

53. Press a 1 1/2" Square Inner Cap (57) into the Leg Lever (15).

Lubricate the 5/16" x 2 1/4" Bolt (62). Attach the Leg Lever (15) to the Rear Seat Frame (16) with the Bolt and a 5/16" Nylon Locknut (40). **Do not overtighten the Nylon Locknut; the Leg Lever must pivot freely.**

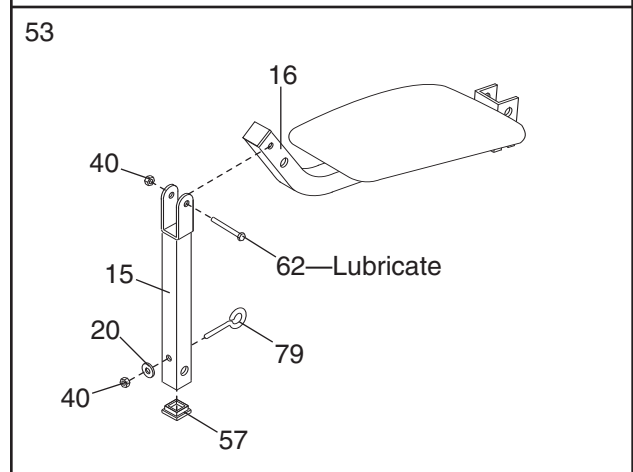

Insert the 5/16" x 2" Eyebolt (79) into the Leg Lever (15) from the direction shown. Tighten a 5/16" Nylon Locknut (40) with a 5/16" Washer (20) onto the Eyebolt.

54. Rest the slot in the Rear Seat Frame (16) on the indicated post in the Ab Upright (1). Attach the Rear Seat Frame to the Ab Upright with a 5/16" x 2 3/4" Carriage Bolt (77) and the Seat Knob (30).

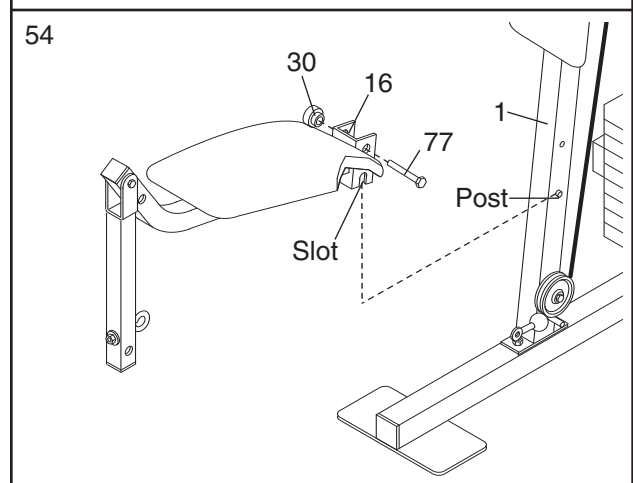

55. Press two 3/4" Round Inner Caps (78) into each Pad Tube (28).

Insert a Pad Tube (28) into the Rear Seat Frame (16). Slide a Foam Pad (29) onto each end of the Pad Tube.

Insert the other Pad Tube (28) into the Leg Lever (15). Slide a Foam Pad (29) onto each end of the Pad Tube.

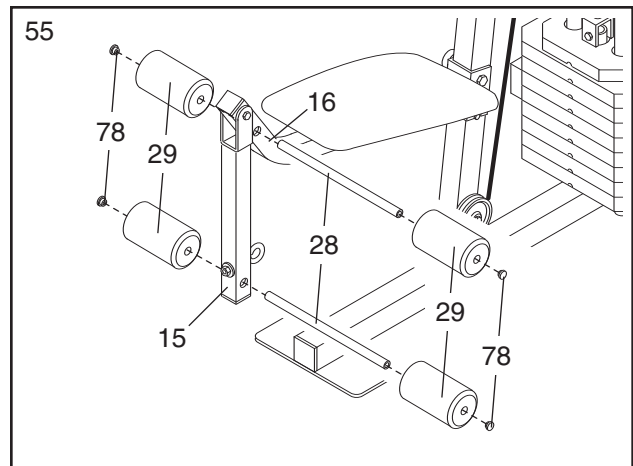

56. Attach the Large Backrest (19) to the Leg Press Upright (4) with two 1/4" x 2 1/2" Machine Screws (64) and two 1/4" Washers (37).

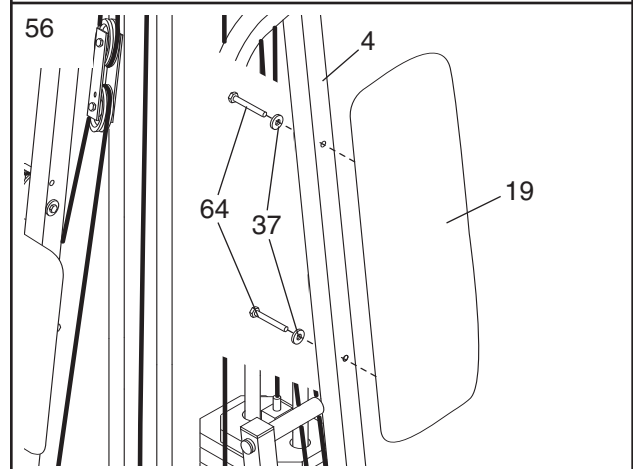

57. Insert a 1/4" x 2 1/2" Carriage Bolt (60) through the center hole in a Seat Plate (41). Attach the Seat Plate to the Seat (17) with two 1/4" x 3/4" Screws (59).

Insert the 1/4" x 2 1/2" Carriage Bolt (60) through the indicated hole in the Front Seat Frame (8). Tighten a 1/4" Nylon Locknut (44) with a 1/4" Washer (37) onto the Carriage Bolt.

Attach the other end of the Seat (17) to the Front Seat Frame (8) with a 1/4" Washer (37) and a 1/4" x 2 1/2" Machine Screw (64).

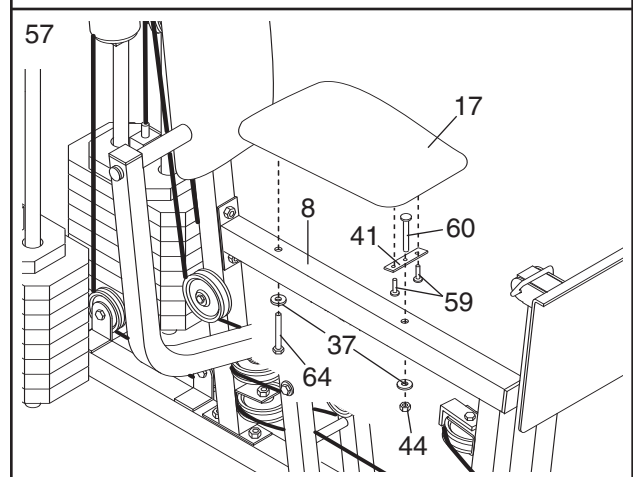

58. Make sure that all parts have been properly tightened. The use of the remaining parts will be explained in HOW TO USE THE TRAINING SYSTEM, beginning on page 22 of this manual.

Before using the training system, pull each cable a few times to be sure that the cables move smoothly over the pulleys. If one of the cables does not move smoothly, find and correct the problem. **IMPORTANT: If the cables are not properly installed, they may be damaged when heavy weight is used. See the CABLE DIAGRAMS on page 26 and 27 of this manual for proper cable routing. If there is any slack in the cables, you will need to remove the slack by tightening the cables. See TROUBLE-SHOOTING AND MAINTENANCE on page 25.**

HOW TO USE THE TRAINING SYSTEM

The instructions below describe how each part of the training system can be adjusted. Refer to the exercise poster accompanying this manual to see how the training system should be set up for each exercise. **IMPORTANT: When attaching the lat bar or nylon strap, make sure that the attachments are in the correct starting position for the exercise to be performed. If there is any slack in the cables or chain as an exercise is performed, the effectiveness of the exercise will be reduced.**

CHANGING THE WEIGHT SETTING

The WEIDER 8630 features two weight stacks. The one weight stack is connected to the ab, upper, and lower pulley stations. The other weight stack is connected to the fly and press arms and the leg press.

To change the weight setting of either weight stack, insert a Weight Pin (93) under the desired Weight (90). Insert the Weight Pin until the bent end of the Weight Pin is touching the Weights, and turn the bent end downward. The weight setting of either weight stack can be changed from 6.5 pounds to 106.5 pounds, in increments of 12.5 pounds. **Note: Due to the cables and pulleys, the amount of resistance at each exercise station may vary from the weight setting. Use the WEIGHT RESISTANCE CHART on page 24 to find the approximate amount of resistance at each weight station.**

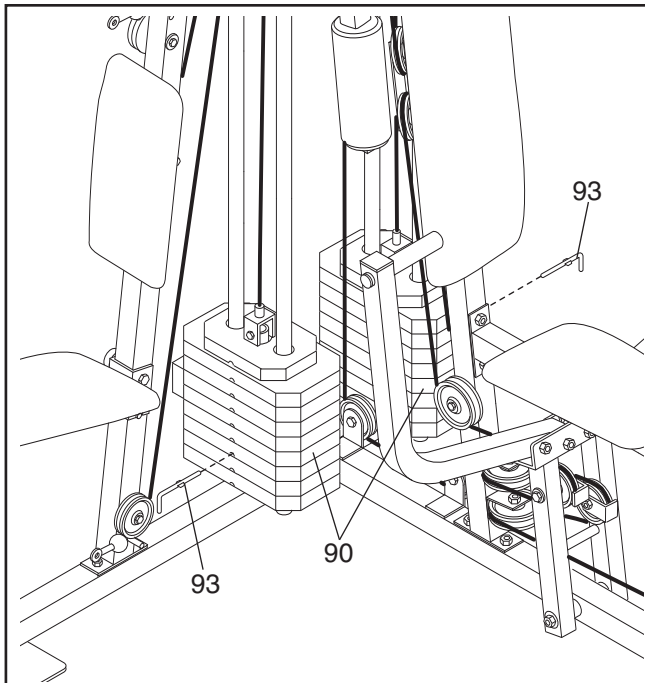

ATTACHING THE LAT BAR OR NYLON STRAP TO THE HIGH PULLEY STATION

Attach the Lat Bar (36) to the High Cable (85) with a Cable Clip (33). For some exercises, the Chain (34) should be attached between the Lat Bar and the High Cable with two Cable Clips. **Adjust the length of the Chain between the Lat Bar and the High Cable so the Lat Bar is in the correct starting position for the exercise to be performed.**

The Nylon Strap (96) can be attached in the same manner.

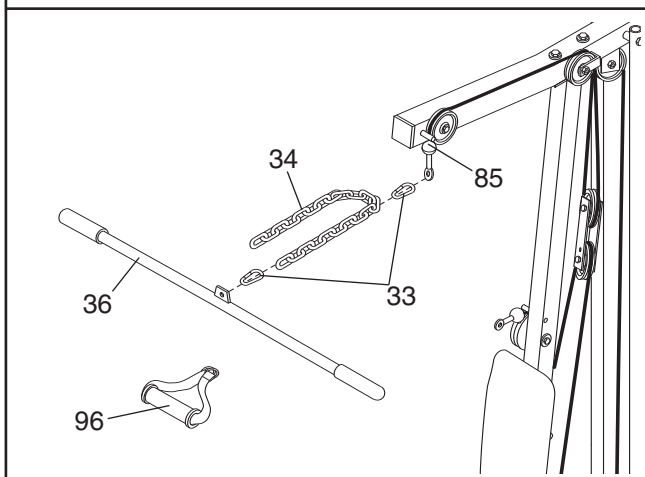

ATTACHING THE LAT BAR OR NYLON STRAP TO THE LOW PULLEY STATION

Attach the Lat Bar (36) to the Low Cable (86) with a Cable Clip (33). For some exercises, the Chain (34) should be attached between the Lat Bar and the Low Cable with two Cable Clips. **Adjust the length of the Chain between the Lat Bar and the Low Cable so the Lat Bar is in the correct starting position for the exercise to be performed.**

The Nylon Strap (96) can be attached in the same manner.

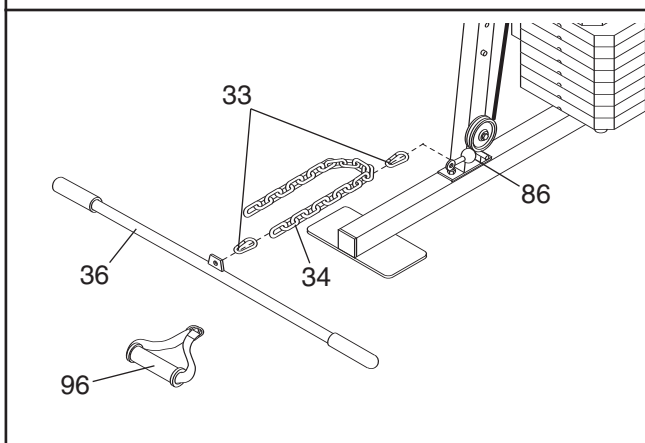

ATTACHING THE AB STRAP TO THE AB PULLEY STATION

Attach the Ab Strap (35) to the Low Cable (86) at the ab pulley station with a Cable Clip (33).

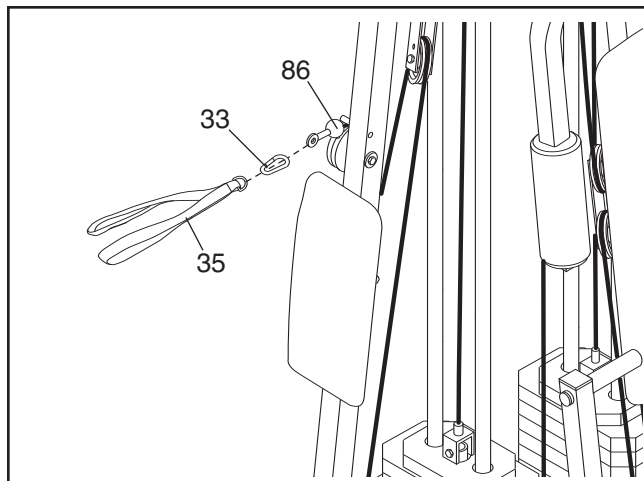

ATTACHING AND REMOVING THE SEAT

To attach the Seat (17), set the bracket on the Rear Seat Frame (16) onto the pins on the Ab Upright (1). Attach the Rear Seat Frame to the Ab Upright with the 5/16" x 2 3/4" Carriage Bolt (77) and the Seat Knob (30).

For some exercises, the Seat (17) must be removed. First, be sure that the chain is not attached to the leg lever. Next, remove the Seat Knob (30) and the 5/16" x 2 3/4" Carriage Bolt (77) from the Rear Seat Frame (16). Lift the Rear Seat Frame off the Ab Upright (1).

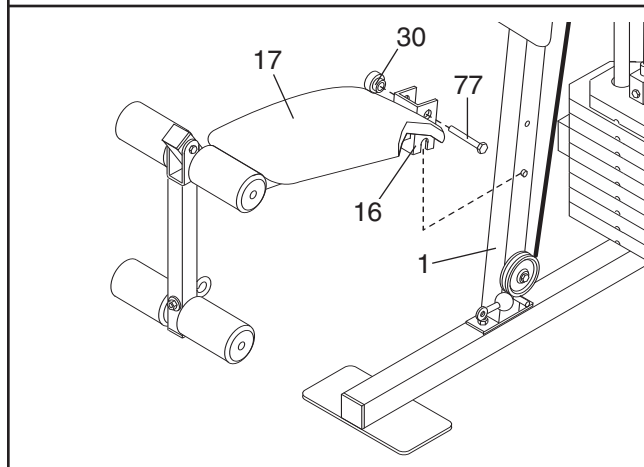

ATTACHING THE LEG LEVER TO THE LOW PULLEY STATION

To use the Leg Lever (15), the seat must be attached to the front upright (see ATTACHING AND REMOVING THE SEAT above).

Attach one end of the Chain (34) to the Low Cable (86) with a Cable Clip (33). Attach the other end of the Chain to the Eyebolt (79) with a Cable Clip.

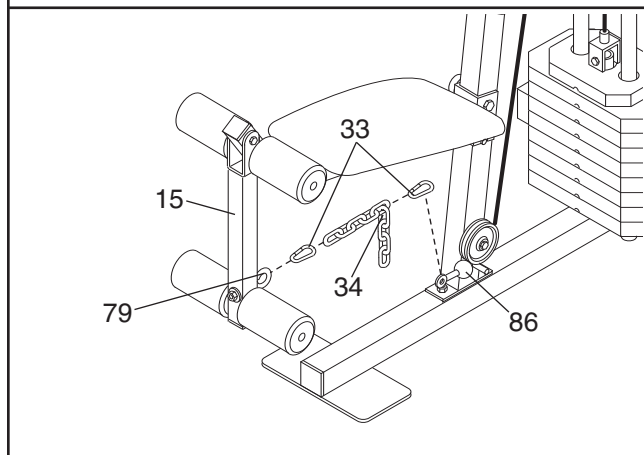

ADJUSTING THE LEG PRESS PLATE

Remove the Lock Pin (73) from the Adjustment Tube (10).

Align the holes in the Leg Press Arm (9) with the desired set of holes in the Adjustment Tube (10). Reinsert the Lock Pin (73) through the holes in the Leg Press Arm and the holes in the Adjustment Tube. **Be sure that the hook on the Lock Pin is clipped in place on the Adjustment Tube.**

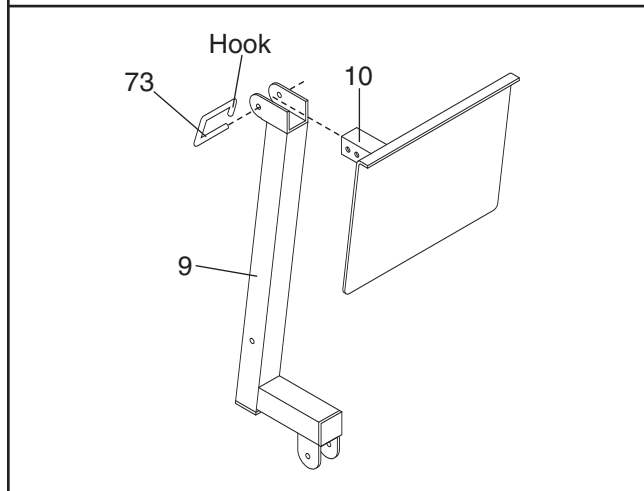

WEIGHT RESISTANCE CHART

This chart shows the approximate weight resistance at each weight station. "Top" refers to the 6.5 lb. top weight. The other numbers refer to the 12.5 lb. weight plates. The butterfly arm resistance listed is the resistance for each butterfly arm.

WEIGHT PLATES	PRESS ARM (lbs.)	BUTTERFLY ARM (lbs.)	LEG LEVER (lbs.)	HIGH PULLEY (lbs.)	LOW PULLEY (lbs.)	LEG PRESS (lbs.)	AB PULLEY (lbs.)
Top	27	20	9	10	10	52	10
1	53	37	18	24	24	94	25
2	79	50	33	40	41	141	40
3	101	65	38	53	53	180	53
4	125	83	48	66	63	228	68
5	148	103	58	80	80	263	83
6	175	120	68	96	91	310	96
7	205	143	76	107	101	358	110
8	240	173	90	123	120	410	124

The actual resistance at each weight station may vary due to differences in individual weight plates, as well as friction between the cables, pulleys, and weight guides.

TROUBLE-SHOOTING AND MAINTENANCE

Inspect and tighten all parts each time you use the training system. Replace any worn parts immediately. The training system can be cleaned using a damp cloth and mild non-abrasive detergent. Do not use solvents.

TIGHTENING THE CABLES

Woven cable, the type of cable used on the training system, can stretch slightly when it is first used. If there is slack in the cables before resistance is felt, the cables should be tightened. If any slack is felt when using the weight stack closest to the ab upright, both the High Cable (85) and the Low Cable (86) will need to be tightened. If any slack is felt when using the other weight stack, the Rear Cable (87), the Press Cable (88), and the Butterfly Cable (89) will need to be tightened.

To tighten the cables, first insert the weight pin into the middle of the weight stack. Slack can be removed from these cables several ways:

- See drawing 1. Tighten the 1/4" Nylon Locknut (44) that connects the end of the Press Cable (88) to the Large "U" Bracket (84).
- See drawing 1. Remove the 3/8" Nylon Locknut (42) and the 3/8" x 2" Bolt (50) from the Cable Trap (80), Pulley, and Large "U" Bracket (84). Reattach the Pulley and Cable Trap to the other hole in the Large "U" Bracket. Be sure that the Cable Trap is in the proper position and that the Cable and Pulley move smoothly.
- See drawing 2. Tighten the 1/4" Nylon Locknut (44) that connects the end of the High Cable (85) to the Small "U" Bracket (32).

The Rear Cable (87) can be tightened in the same manner.

- See Drawing 3. If you feel additional slack while using the training system, the Low Cable (86) and the Press Cable (88) can be tightened further.

Remove the 3/8" x 2" Bolts (50), the 3/8" Nylon Locknuts (42), the 3 1/3" Pulleys (82), and the Cable Traps (80) from the Pulley Plates (31). Reattach the upper Pulley **without the Cable Trap**. Reattach the lower Pulley to the higher hole in the Pulley Plates **without the Cable Trap**. Keep the Cable Traps for future use. Be sure that the Cable and Pulley move smoothly.

Do not overtighten the cables. If the cables are overtightened, the top weight will be lifted off the weight stack.

If a cable tends to slip off the pulleys often, it may have become twisted. Remove the cable and re-install it.

If the cables need to be replaced, see ORDERING REPLACEMENT PARTS on the back cover of this manual.

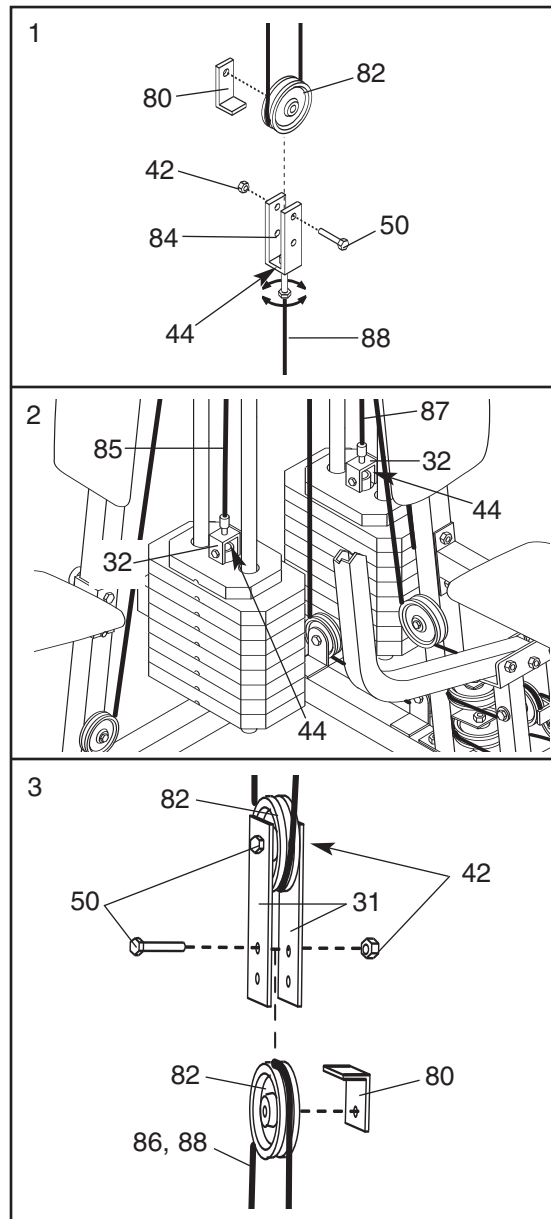

CABLE DIAGRAMS

The cable diagrams on this page and the next page show the proper routing of the High Cable (85), the Low Cable (86), the Rear Cable (87), the Press Cable (88), and the Butterfly Cable (89). Use the diagrams to be sure that the Cables have been assembled correctly. The starting and ending points of each Cable have been labeled. The numbers show the proper route for each Cable. **IMPORTANT: If the Cables have not been correctly routed, the WEIDER 8630 will not function properly and damage may occur.**

Press Cable (88)

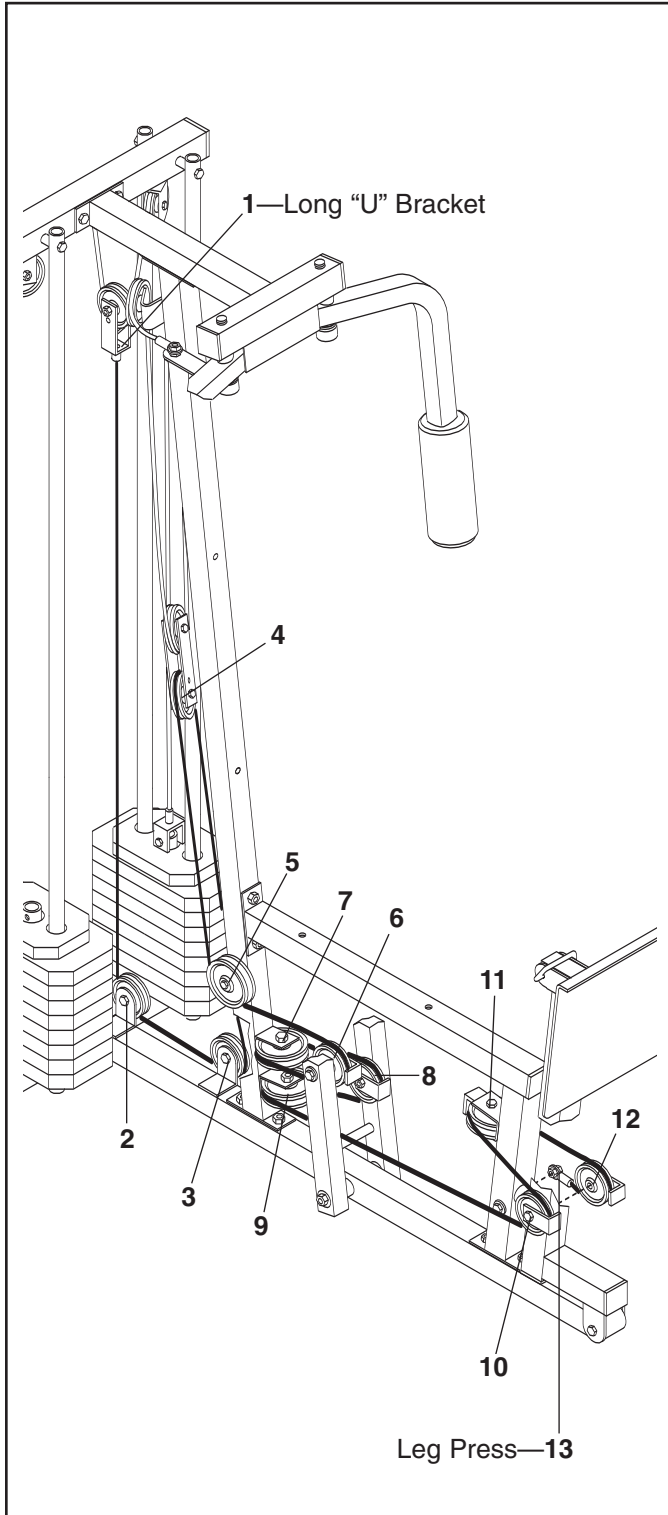

Low Cable (86)

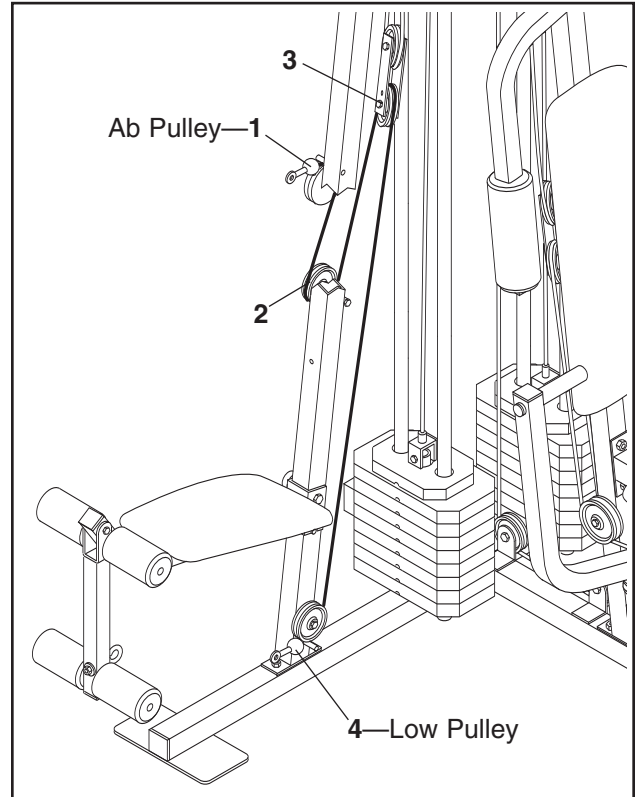

Butterfly Cable (89)

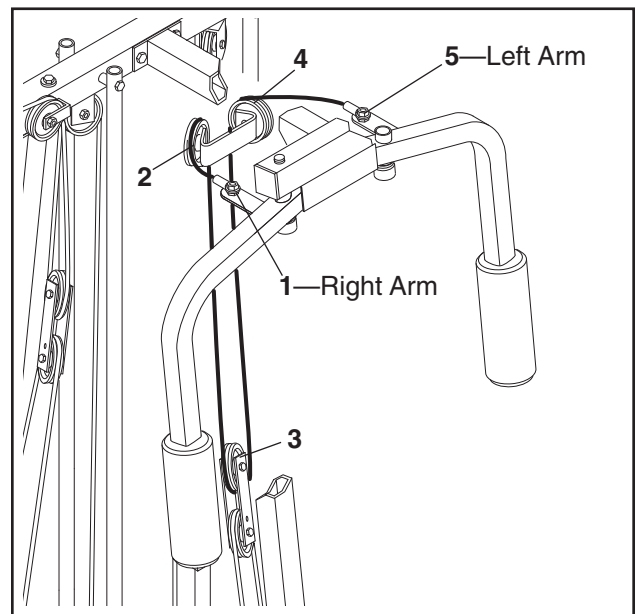

High Cable (85)

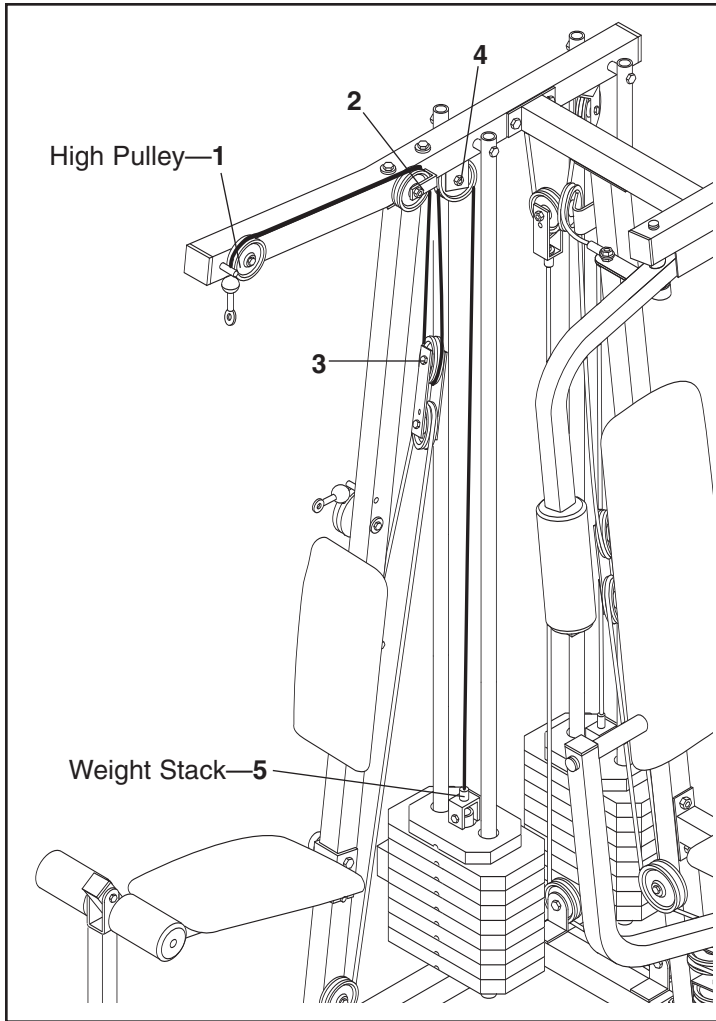

Rear Cable (87)

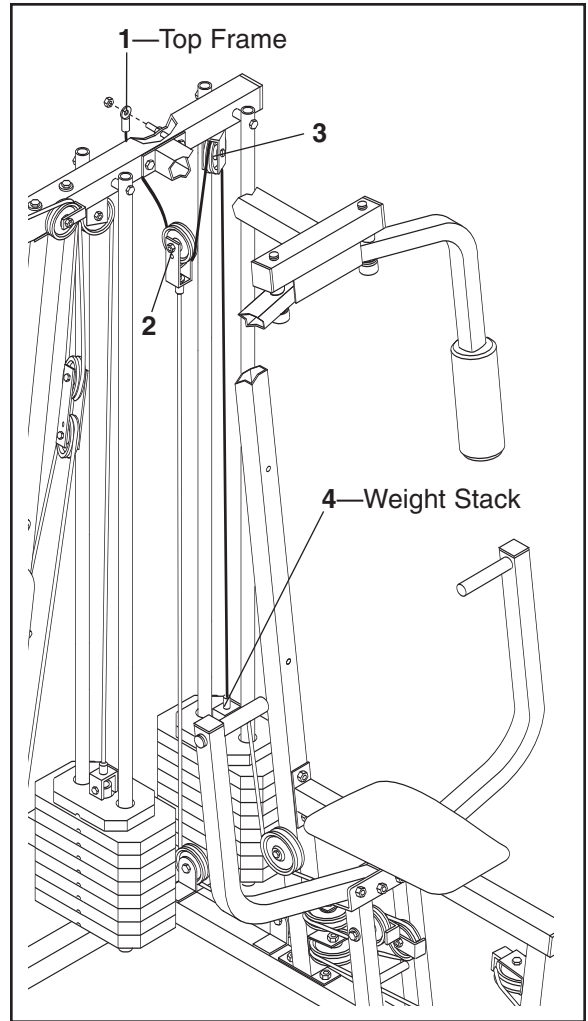

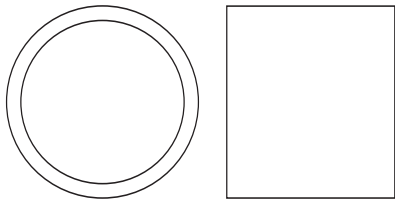

1" x 7/8" Plastikbucshe (54)

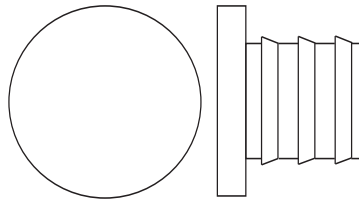

1" Innenkapp[e] (98)

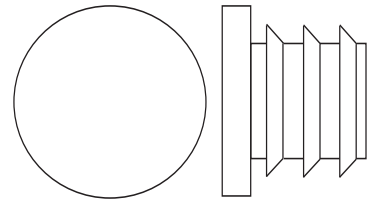

1" Runde Innenkappe (70)

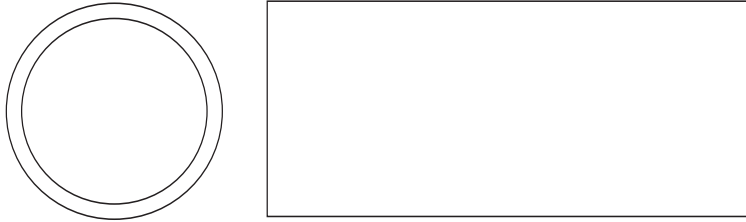

1 1/8" x 2 1/2" Plastikbucshe (47)

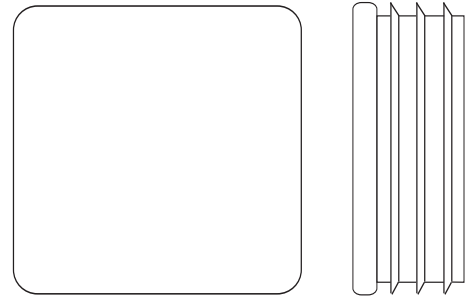

1 1/2" Quadratische Innenkappe (57)

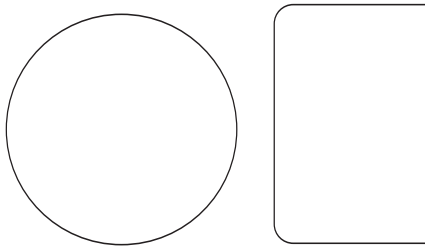

1" Runde Außenkappe (46)

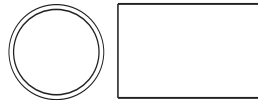

1/2" x 3/4" Abstandsstück (69)

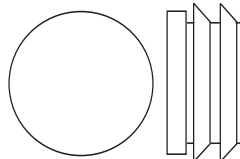

3/4" Runde Innenkappe (78)

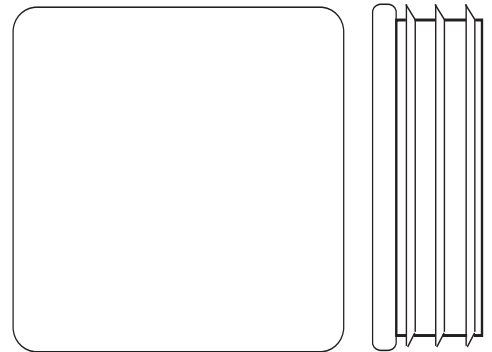

1 3/4" Quadratische Innenkappe (48)

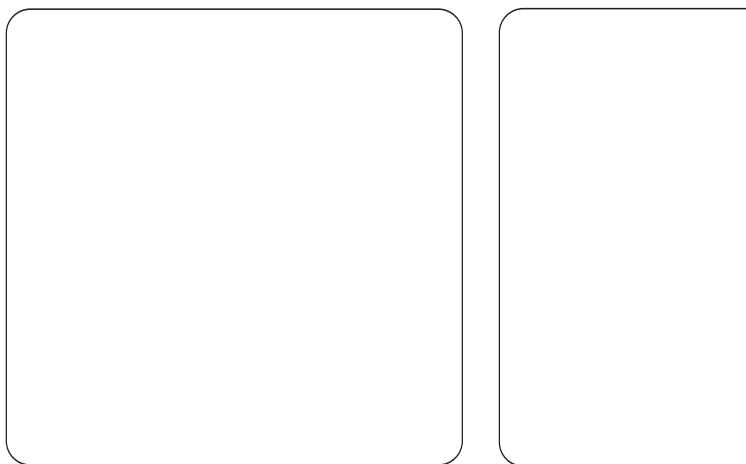

2" Quadratische Außenkappe(58)

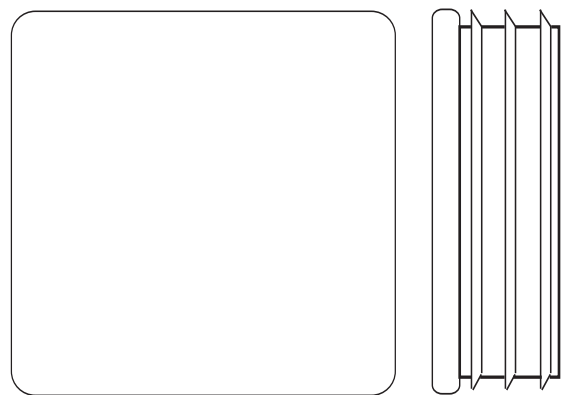

2" Quadratische Innenkappe (56)

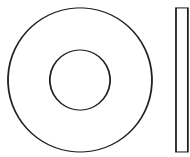

1/4" Unterlegscheibe (37)

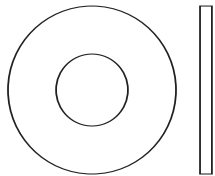

5/16" Unterlegscheibe (20)

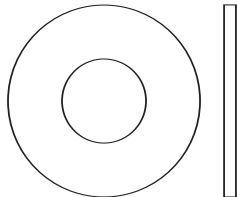

3/8" Unterlegscheibe (38)

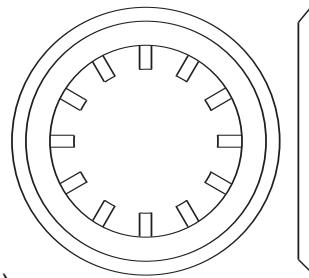

1" Spannringe (45)

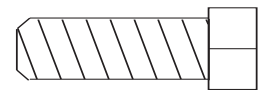

5/16" x 1" Bolzen (51)

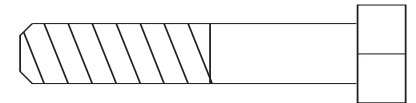

5/16" x 1 3/4" Bolzen (68)

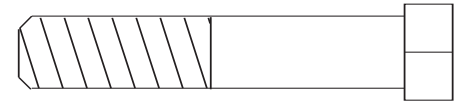

3/8" x 2" Bolzen (50)

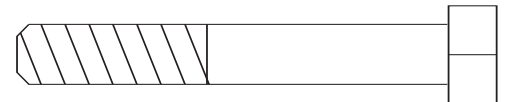

5/16" x 2 1/4" Bolzen (62)



5/16" x 2 1/2" Bolzen (39)



3/8" x 2 1/2" Bolzen (65)-1



5/16" x 2 3/4" Bolzen (55)

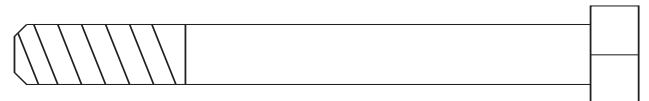

5/16" x 3" Bolzen (92)



3/8" x 3 1/4" Bolzen (71)



3/8" x 3 1/2" Bolzen (66)



1/4" Nylonverschlußmutter(44)



5/16" Nylonverschlußmutter (40)



5/16" Nylonkontermutter (91)



3/8" Nylonverschlußmutter (42)

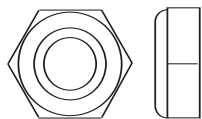

3/8" Nylonkontermutter (43)

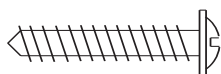

1" Schraubenbolzen (72)

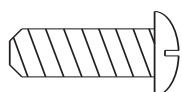

1/4" x 3/4" Schraube (59)

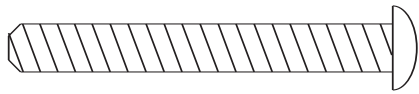

1/4" x 2" Maschinenschraube (63)

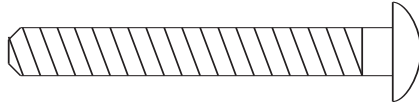

1/4" x 2" Schraubenbolzen (61)

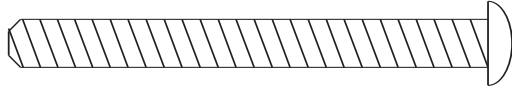

1/4" x 2 1/2" Maschinenschraube (64)

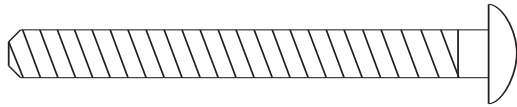

1/4" x 2 1/2" Schraubenbolzen (60)

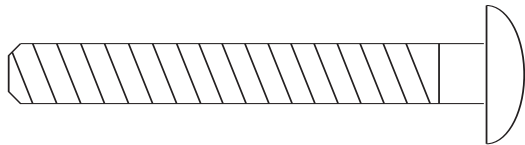

5/16" x 2 1/2" Schraubenbolzen (49)

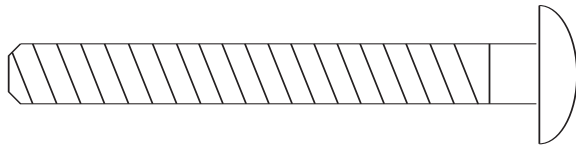

5/16" x 2 3/4" Schraubenbolzen (77)

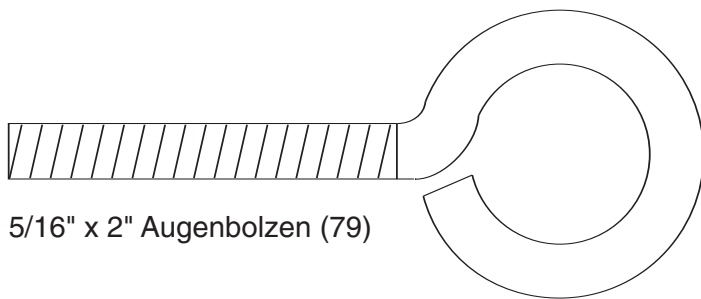

5/16" x 2" Augenbolzen (79)

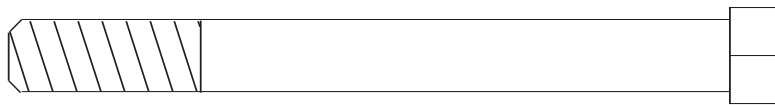

3/8" x 3 3/4" Bolzen (76)

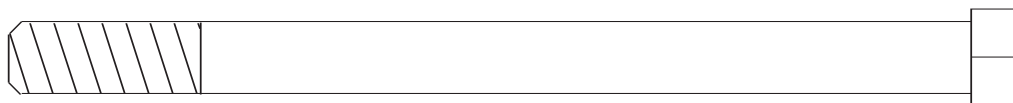

3/8" x 5" Bolzen (74)

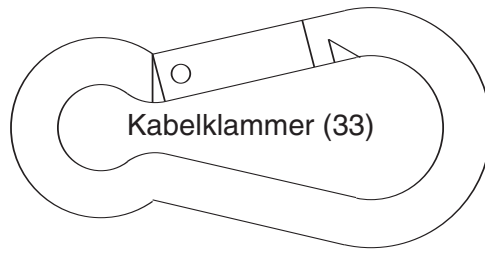

Kabelklammer (33)

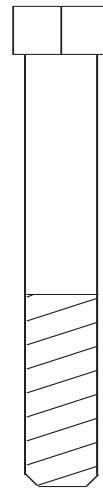

3/8" x 2 1/4" Bolzen (97)



3/8" x 4" Bolzen (95)



5/16" x 6" Bolzen (67)

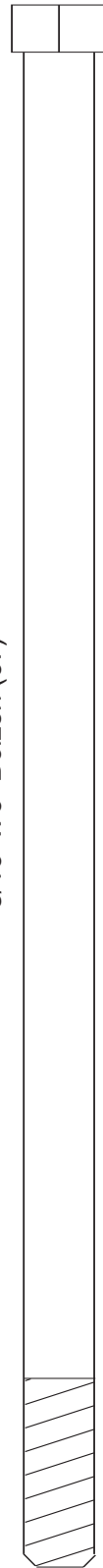

3/8" x 8" Bolzen (52)

PART LIST—Model No. WESY86303

R0100A

Key No.	Qty.	Description	Key No.	Qty.	Description
1	1	Ab Upright	51	2	5/16" x 1" Bolt
2	1	Top Frame	52	1	3/8" x 8" Bolt
3	1	Butterfly Frame	53	1	Leg Press Bumper
4	1	Leg Press Upright	54	2	1" x 7/8" Plastic Bushing
5	1	Right Fly Arm	55	10	5/16" x 2 3/4" Bolt
6	1	Left Fly Arm	56	8	2" Square Inner Cap
7	2	Press Arm	57	2	1 1/2" Square Inner Cap
8	1	Front Seat Frame	58	2	2" Square Outer Cap
9	1	Leg Press Arm	59	4	1/4" x 3/4" Screw
10	1	Adjustment Tube	60	1	1/4" x 2 1/2" Carriage Bolt
11	1	Leg Press Plate	61	1	1/4" x 2" Carriage Bolt
12	1	Press Frame	62	1	5/16" x 2 1/4" Bolt
13	1	Press Base	63	1	1/4" x 2" Machine Screw
14	1	Weight Base	64	5	1/4" x 2 1/2" Machine Screw
15	1	Leg Lever	65	1	3/8" x 2 1/2" Bolt
16	1	Rear Seat Frame	66	2	3/8" x 3 1/2" Bolt
17	2	Seat	67	4	5/16" x 6" Bolt
18	1	Small Backrest	68	2	5/16" x 1 3/4" Bolt
19	1	Large Backrest	69	8	1/2" x 3/4" Spacer
20	13	5/16" Washer	70	2	1" Round Inner Cap
21	4	5" Plastic Grip	71	1	3/8" x 3 1/4" Bolt
22	2	10" Pad	72	1	1" Tap Screw
23	4	Weight Guide	73	1	Lock Pin
24	2	Top Weight	74	1	3/8" x 5" Bolt
25	2	Weight Tube	75	2	Press Bushing
26	2	Weight Tube Bumper	76	5	3/8" x 3 3/4" Bolt
27	4	Weight Bumper	77	1	5/16" x 2 3/4" Carriage Bolt
28	2	Pad Tube	78	4	3/4" Round Inner Cap
29	4	Foam Pad	79	1	5/16" x 2" Eyebolt
30	1	Seat Knob	80	16	Cable Trap
31	4	Pulley Plate	81	3	"V" Pulley
32	2	Small "U" Bracket	82	21	3 1/2" Pulley
33	4	Cable Clip	83	1	Large Cable Trap
34	1	Chain	84	1	Large "U" Bracket
35	1	Ab Strap	85	1	High Cable
36	1	Lat Bar	86	1	Low Cable
37	11	1/4" Washer	87	1	Rear Cable
38	8	3/8" Washer	88	1	Press Cable
39	5	5/16" x 2 1/2" Bolt	89	1	Butterfly Cable
40	28	5/16" Nylon Locknut	90	16	Weight
41	2	Seat Plate	91	8	5/16" Nylon Jam Nut
42	21	3/8" Nylon Locknut	92	1	5/16" x 3" Bolt
43	4	3/8" Nylon Jam Nut	93	2	Weight Pin
44	5	1/4" Nylon Locknut	94	2	Pulley Cover
45	4	1" Retainer	95	1	3/8" x 4" Bolt
46	2	1" Round Outer Cap	96	1	Nylon Strap
47	2	1 1/8" x 2 1/2" Plastic Bushing	97	2	3/8" x 2 1/4" Bolt
48	7	1 3/4" Square Inner Cap	98	2	Inner Cap
49	6	5/16" x 2 1/2" Carriage Bolt	#	1	User's Manual
50	11	3/8" x 2" Bolt	#	1	Exercise Poster

Note: "#" indicates a non-illustrated part. Specifications are subject to change without notice.

REMOVE THIS PART IDENTIFICATION CHART FROM THE MANUAL

This chart is provided to help you identify the small parts used in assembly. **Important: Some parts may have been pre-assembled for shipping purposes. If you cannot find a part in the parts bags, check to see if it has been pre-assembled.** The number in parenthesis following each part description refers to the key number of the part.

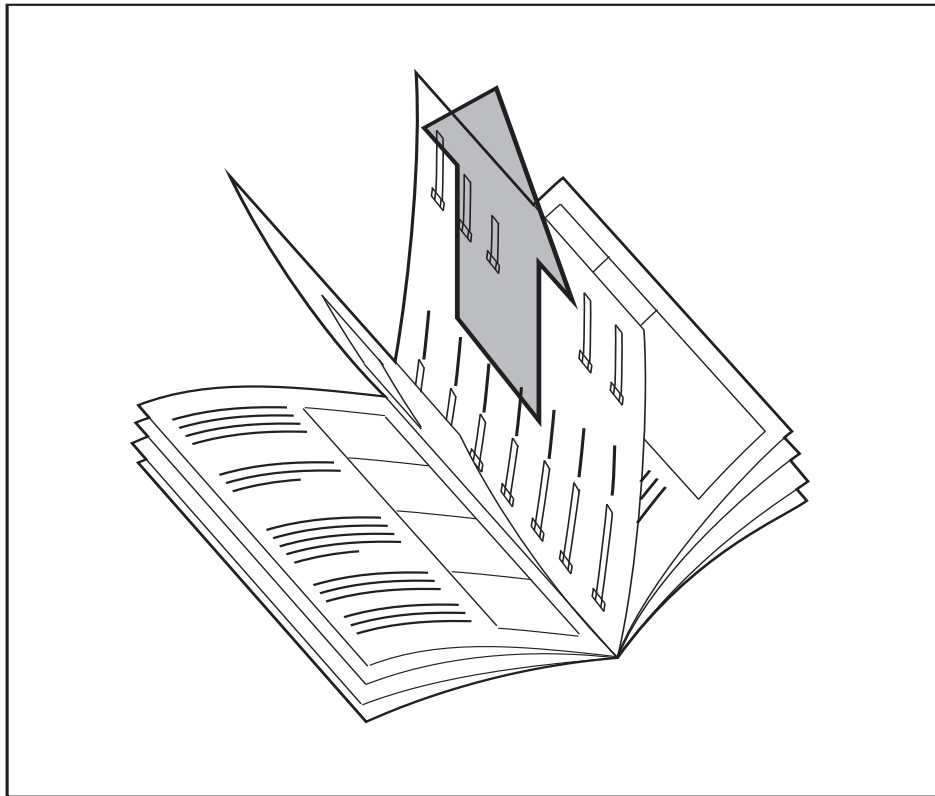

Please Note: The assembly is divided into four stages: 1) frame assembly, 2) arm assembly, 3) cable assembly, and 4) seat assembly. The hardware for each stage is packaged separately. WAIT UNTIL YOU BEGIN EACH ASSEMBLY STAGE TO OPEN THE PARTS BAG LABELED FOR THAT ASSEMBLY STAGE.

**REMOVE THIS PART LIST/EXPLODED
DRAWING FROM THE MANUAL. SAVE
THE PART LIST/EXPLODED DRAWING
FOR FUTURE REFERENCE.**

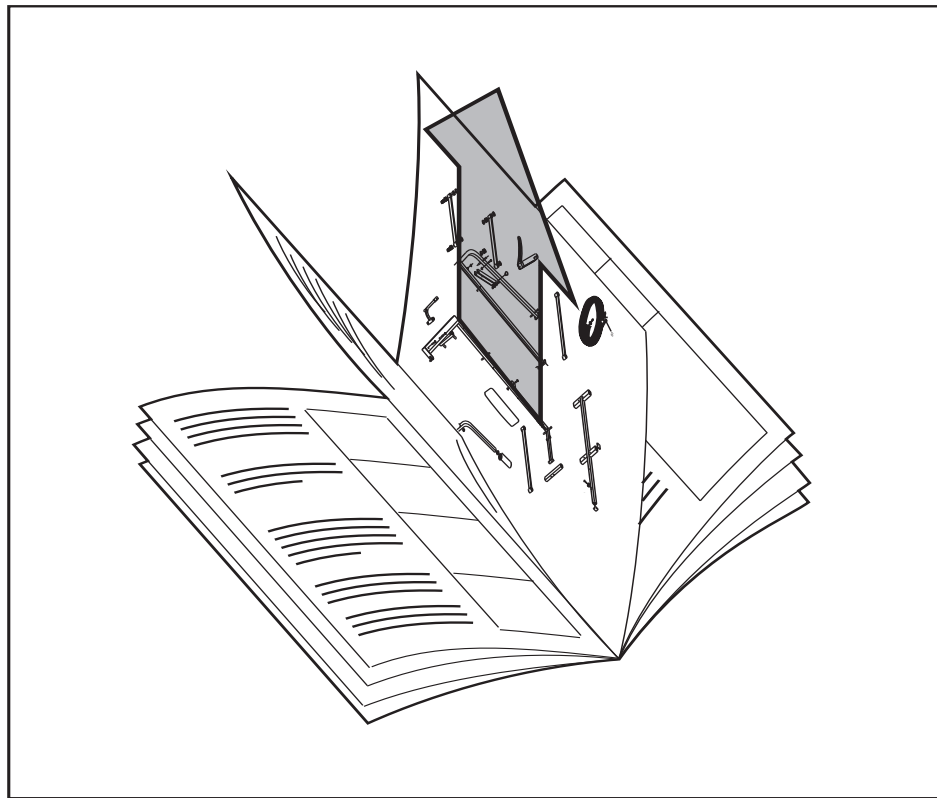

EXPLODED DRAWING—Model No. WESY86303

R0100A

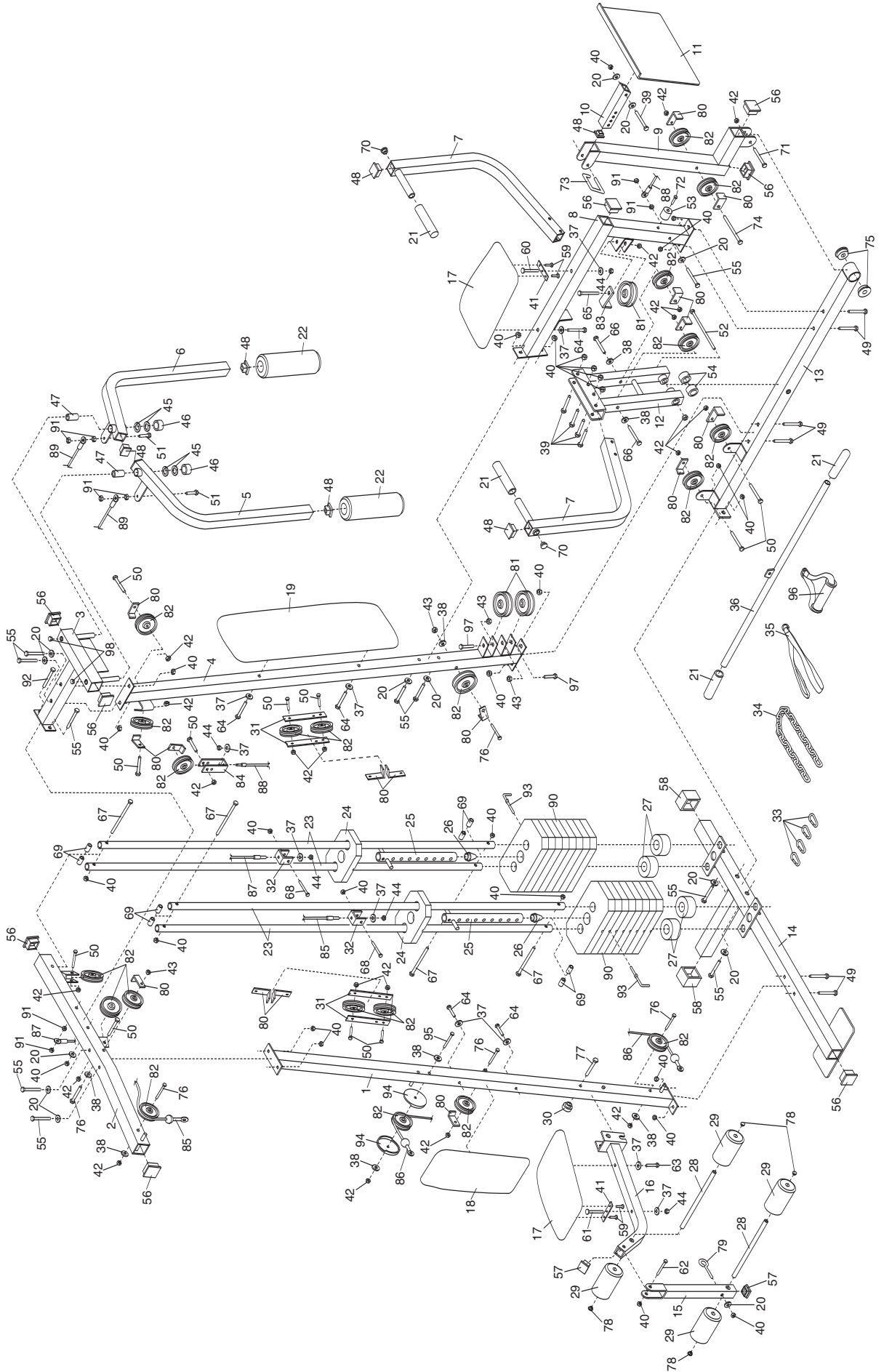

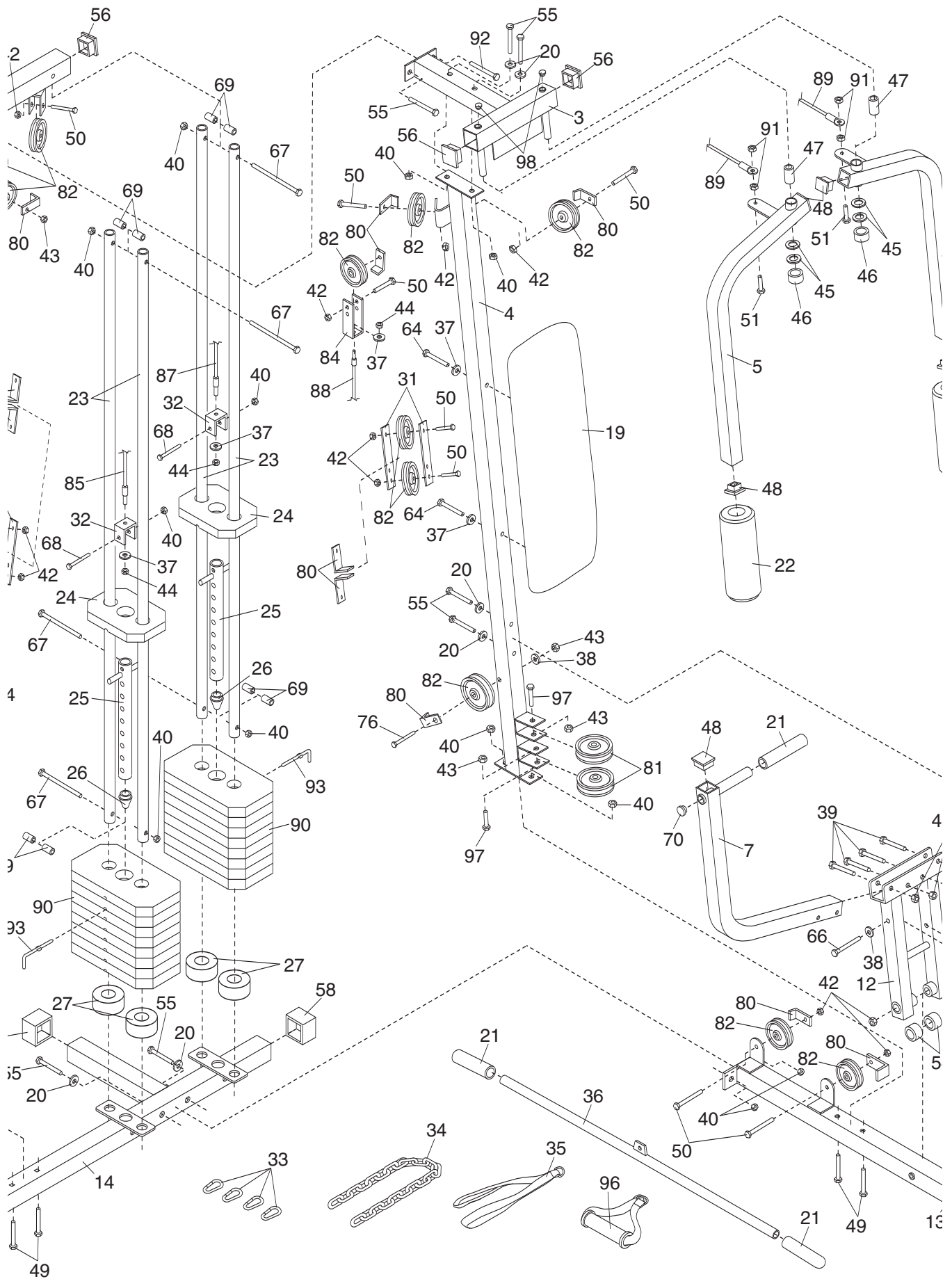

ORDERING REPLACEMENT PARTS

To order replacement parts, simply call our Customer Service Department toll-free at 1-800-999-3756, Monday through Friday, 6 a.m. until 6 p.m. Mountain Time (excluding holidays). To help us assist you, please be prepared to give the following information:

1. The MODEL NUMBER of the product (WESY86303)
2. The NAME of the product (WEIDER® 8630 Training System)
3. The SERIAL NUMBER of the product (see the front cover of this manual)
4. The KEY NUMBER and DESCRIPTION of the part(s) (see the PART LIST and EXPLODED DRAWING attached at the center of this manual).

Free Manuals Download Website

<http://myh66.com>

<http://usermanuals.us>

<http://www.somanuals.com>

<http://www.4manuals.cc>

<http://www.manual-lib.com>

<http://www.404manual.com>

<http://www.luxmanual.com>

<http://aubethermostatmanual.com>

Golf course search by state

<http://golfingnear.com>

Email search by domain

<http://emailbydomain.com>

Auto manuals search

<http://auto.somanuals.com>

TV manuals search

<http://tv.somanuals.com>