



WEIL-McLAIN

GOLD CGs

Gas-Fired Water Boilers

Boiler Manual

- Installation
- Maintenance
- Startup
- Parts



▲WARNING

This manual must only be used by a qualified heating installer/service technician. **Before installing**, read all instructions, including this manual, the burner manual and any related supplements. Perform steps in the order given. Failure to comply could result in severe personal injury, death or substantial property damage.

▲WARNING

DO NOT USE BOILER DURING CONSTRUCTION unless you provide dust-free air to the boiler area or follow the requirements given on page 9. Failure to comply could result in severe personal injury, death or substantial property damage.



How it works . . .

- ① **Control module**
 The control module responds to signals from the room thermostat, air pressure switch and boiler limit circuit to operate the boiler circulator, pilot burner, gas valve and inducer. When room thermostat calls for heat, the control module starts the system circulator and inducer. The control module runs the inducer long enough to purge the boiler flue passages, then opens the pilot valve and activates pilot ignition spark. The control module allows up to 15 seconds to establish pilot flame. If flame is not sensed within 15 seconds, the control module will turn off the gas valve, flash the Flame light, and then enter a 15-second postpurge. The control module will then start a new cycle. This will continue indefinitely until pilot flame is established or power is interrupted. Once pilot flame is proven, the control module opens the gas valve to allow main burner flame. When the room thermostat is satisfied, the control module turns off the gas valve, operates the inducer for a 15-second postpurge and waits for the next heat call. The control module indicator lights show normal sequence when the lights are on steady. When a problem occurs, the control module flashes combinations of lights to indicate the most likely reason for the problem (see page 45).
- ② **Transformer**
 The control transformer reduces line voltage to 24 volts for the gas valve and limit circuit.
- ③ **Inducer**
 The inducer pulls flue gases through the boiler, causing air to be pulled in through the air intake opening. The inducer pushes the flue gases through the vent pipe as well.
- ④ **Air pressure switch**
 The air pressure switch signals the control module, telling the control module whether air is moving through the inducer.
- ⑤ **Water temperature limit switch**
 The water temperature limit switch turns off the gas valve if the temperature in the boiler goes above its setting. (The circulator will continue to run as long as there is a call for heat.)
- ⑥ **Boiler circulator**
 The boiler circulator circulates water through the external (system) piping. The circulator is shipped loose, and can be mounted on either the boiler supply or return piping. The factory-installed circulator wiring harness provides ample length for either location. **NOTE** — The control module provides a pump exercising routine. If the boiler is not operated for 30 days, the control module will power the circulator for 30 seconds, then turn off.

Other boiler components:

a supply to system	f pressure/temperature gauge	k pilot burner and bracket
b return from system	g relief valve (not visible)	l stainless steel burners
c combustion air inlet	h air vent connection	m cast iron boiler sections
d flue outlet	i flame rollout switch	n flue collector
e gas valve	j air inlet box	o junction box



GOLD CGs Gas-Fired Induced-Draft Water Boiler

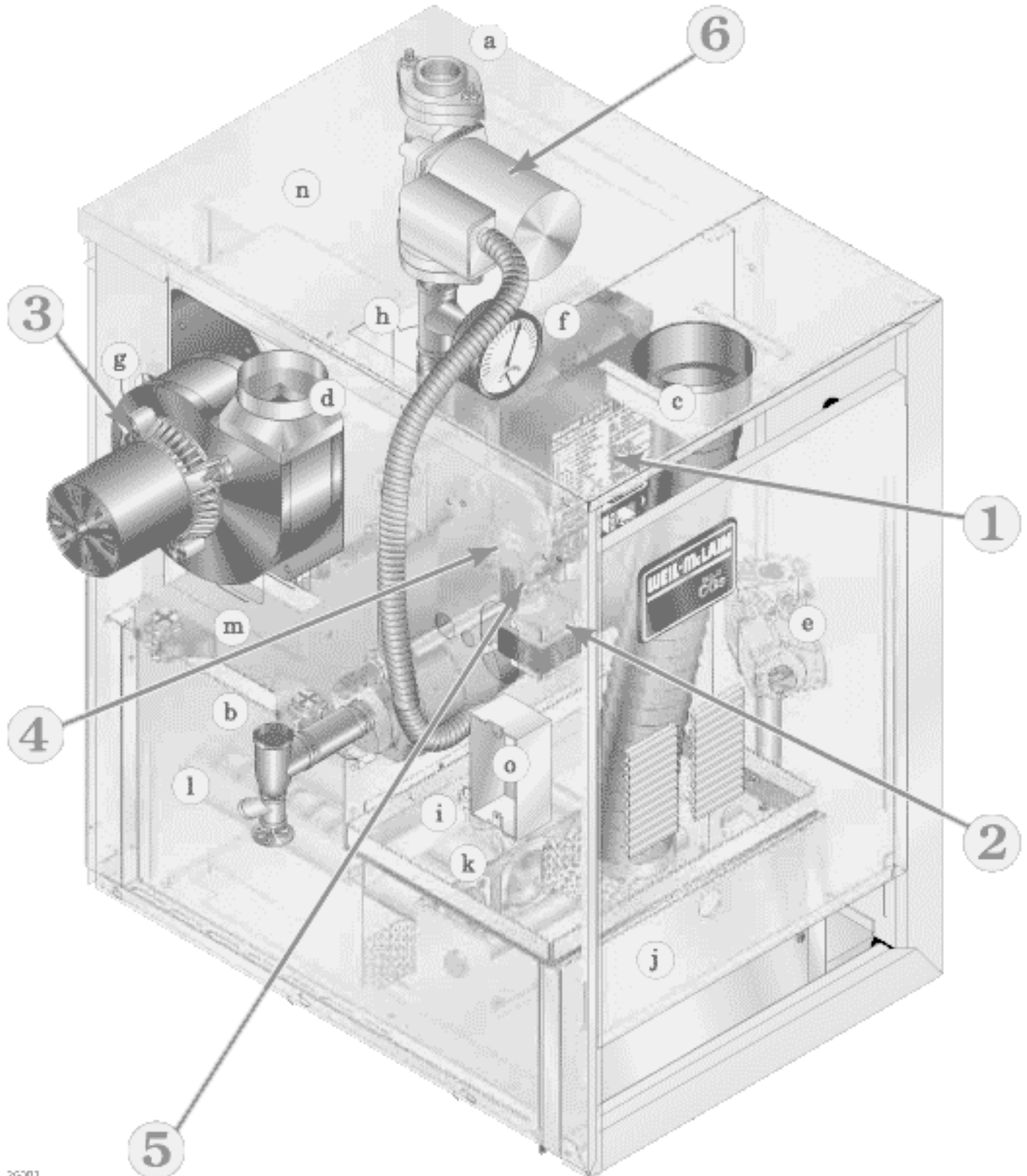

2/2017



Contents

	How it works	2-3
	Hazard definitions	4
	Please read before proceeding	5
1	Prepare boiler location	6-11
2	Prepare boiler	12-13
3	Water piping	14-23
4	Venting & combustion air	24
5	Gas piping	25
6	Field wiring	26
7	Start-up	27-29
8	Check-out procedure	30
9	Operation	31-36
10	Service and maintenance	37-42
11	Troubleshooting	43-53
12	Replacement parts	54-61
13	Dimensions and ratings	62-63

Hazard definitions

The following defined terms are used throughout this manual to bring attention to the presence of hazards of various risk levels or to important information concerning the life of the product.



Indicates presence of hazards that **will cause** severe personal injury, death or substantial property damage.



Indicates presence of hazards that **can cause** severe personal injury, death or substantial property damage.



Indicates presence of hazards that **will or can cause** minor personal injury or property damage.



Indicates special instructions on installation, operation or maintenance that are important but not related to personal injury or property damage.



Please read before proceeding

Installer



Read all instructions before installing. Follow all instructions in proper order to prevent personal injury or death.

- Also refer to CGs Venting Supplements.
- Consider piping and installation when determining boiler location.
- Any claims for damage or shortage in shipment must be filed immediately against the transportation company by the consignee.



The boiler contains ceramic fiber and fiberglass materials. Use care when handling these materials per instructions on page 64 of this manual. Failure to comply could result in severe personal injury.

NOTICE

When calling or writing about the boiler— Please have the boiler model number from the boiler rating label and the CP number from the boiler jacket. You may list the CP number in the space provided on the Installation and service certificate found on page 30.



Failure to adhere to the guidelines on this page can result in severe personal injury, death or substantial property damage.

When servicing boiler —

- To avoid electric shock, disconnect electrical supply before performing maintenance.
- To avoid severe burns, allow boiler to cool before performing maintenance.

Boiler operation —

- Do not block flow of combustion or ventilation air to boiler.
- Should overheating occur or gas supply fail to shut off, do not turn off or disconnect electrical supply to circulator. Instead, shut off the gas supply at a location external to the appliance.
- Do not use this boiler if any part has been under water. Immediately call a qualified service technician to inspect the boiler and to replace any part of the control system and any gas control that has been under water.

Boiler water —

- Do not use petroleum-based cleaning or sealing compounds in boiler system. Water seal deterioration will occur, causing leakage between sections. This can result in substantial property damage.
- Do not use “homemade cures” or “boiler patent medicines”. Serious damage to boiler, personnel and/or property may result.

User

- This manual is for use only by your qualified heating installer/service technician.
- Please refer to the User's Information Manual for your reference.
- We recommend regular service by a qualified service technician, at least annually.

- Continual fresh makeup water will reduce boiler life. Mineral buildup in sections reduces heat transfer, overheats cast iron, and causes section failure. Addition of oxygen and other gases can cause internal corrosion. Leaks in boiler or piping must be repaired at once to prevent makeup water.

- Do not add cold water to hot boiler. Thermal shock can cause sections to crack.

Glycol — potential fire hazard —

All glycol is flammable when exposed to high temperatures. If glycol is allowed to accumulate in or around the boiler or any other potential ignition source, a fire can develop. In order to prevent potential severe personal injury, death or substantial property damage from fire and/or structural damage:

- Never store glycol of any kind near the boiler or any potential ignition source.
- Monitor and inspect the system and boiler regularly for leakage. Repair any leaks immediately to prevent possible accumulation of glycol.
- Never use automotive antifreeze or ethylene glycol in the system. Using these glycols can lead to hazardous leakage of glycol in the boiler system.



1a Prepare boiler location — codes & checklist

Installations must follow these codes:

- Local, state, provincial, and national codes, laws, regulations and ordinances.
- National Fuel Gas Code, ANSI Z223.1–latest edition.
- Standard for Controls and Safety Devices for Automatically Fired Boilers, ANSI/ASME CSD-1, when required.
- National Electrical Code.
- For Canada only: B149.1 or B149.2 Installation Code, CSA C22.1 Canadian Electrical Code Part 1 and any local codes.

NOTICE

The CGs boiler gas manifold and controls met safe lighting and other performance criteria when boiler underwent tests specified in ANSI Z21.13–latest edition.

Before locating the boiler, check the following:

- Check for nearby connection to:
 - System water piping
 - Venting connections
 - Gas supply piping
 - Electrical power
- Check area around boiler. **Remove any combustible materials, gasoline and other flammable liquids, or other contaminants.**
- Check for nearby connection to:
 - System water piping
 - Venting connections
 - Gas supply piping
 - Electrical power
- Check area around boiler. **Remove any combustible materials, gasoline and other flammable liquids, or other contaminants.**

WARNING

Failure to keep boiler area clear and free of **combustible materials, gasoline and other flammable liquids and vapors** can result in severe personal injury, death or substantial property damage.

- Boiler must be installed so that gas control system components are protected from dripping or spraying water or rain during operation or service.
- If new boiler will replace existing boiler, check for and correct system problems, such as:
 1. System leaks causing oxygen corrosion or section cracks from hard water deposits.
 2. Incorrectly-sized expansion tank.
 3. Lack of antifreeze in boiler water causing system and boiler to freeze and leak.



1b Prepare boiler location – clearances

Recommended SERVICE clearances (Fig. 1)

1. Provide clearances for cleaning and servicing the boiler and for access to controls and components. See Figure 1 for recommendations.
2. Provide at least screwdriver clearance to jacket front panel screws for removal of front panel for inspection and minor service. If unable to provide at least screwdriver clearance, install unions and shutoff valves in system so boiler can be moved for servicing.

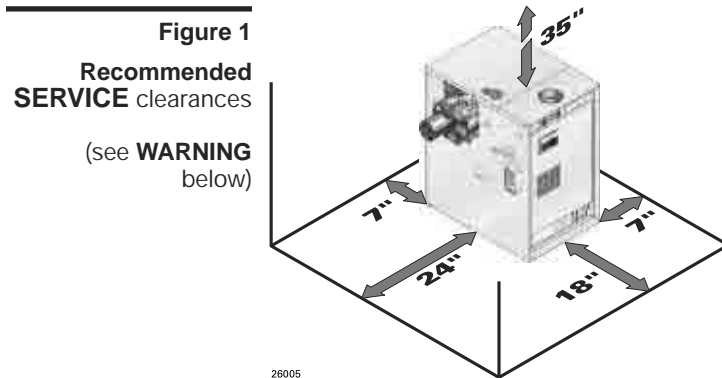

WARNING If any clearance is less than in Figure 1, provide openings for combustion and ventilation air located on the wall or door opposite the boiler FRONT (see Figure 2).

These openings must be located as shown in Figure 2 to provide proper air flow around the boiler. The free area of each opening (after deducting for louvers) must be at least **one square inch per 1,000 Btu/h** of boiler input. If the building is of unusually tight construction (see page 10 for definition), the air openings must connect directly to outside or the building must have air openings to the outside as specified on page 10.

If clearances are equal to or greater than Figure 1, see pages 10 and 11 for location and sizing of combustion air openings.

Failure to comply can result in severe personal injury, death or substantial property damage and reduced boiler life.

Required MINIMUM clearances (Fig. 2)

WARNING Never install the boiler in a space with clearances less than the minimum clearances shown in Figure 2. Failure to comply can result in severe personal injury, death or substantial property damage and reduced boiler life.

1. **Hot water pipes:** at least 1/2 inch from combustible material.
2. **Single-wall vent pipe:** at least 6 inches from combustible material.
3. **Type B double-wall metal vent pipe:** refer to vent manufacturer's recommendation for clearances to combustible material.

Figure 2 Required MINIMUM clearances

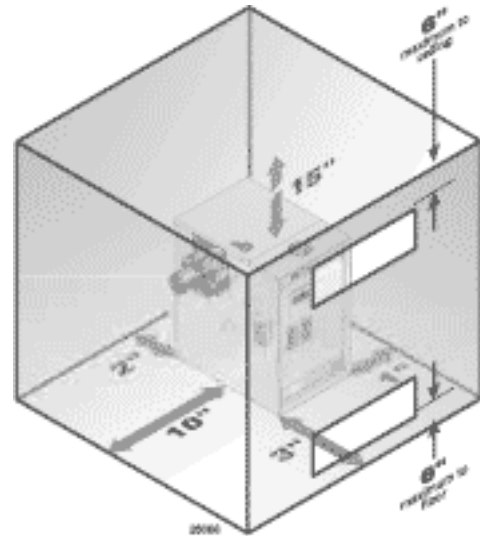

Flooring

The CGi boiler is approved for installation on combustible flooring, but must never be installed on carpeting.

WARNING Do not install boiler on carpeting even if foundation is used. Fire can result, causing severe personal injury, death or substantial property damage.

Foundation

1. Provide a solid brick or minimum 2-inch thick concrete foundation pad if any of the following is true:
 - floor can become flooded.
 - the boiler mounting area is not level.
2. Minimum dimensions are **25" length** by:

Minimum foundation width			
CGs-3	15"	CGs-5	21"
CGs-4	18"	CGs-6	24"

Residential garage installations

Take the following special precautions when installing the boiler in a residential garage. If the boiler is located in a residential garage, per ANSI Z223.1:

- Mount the boiler a minimum of **18 inches above the floor** of the garage to assure the burner and ignition devices will be no less than 18 inches above the floor.
- Locate or **protect the boiler** so it cannot be damaged by a moving vehicle.



1c Prepare boiler location — vent system

⚠ WARNING

Failure to follow all instructions can result in flue gas spillage and carbon monoxide emissions, causing severe personal injury or death.

⚠ DANGER

Inspect existing chimney before installing boiler. Failure to clean or replace perforated pipe or tile lining will cause severe personal injury or death.

⚠ DANGER

DO NOT COMMON VENT — Do not install the CGs into a common vent with any other appliance. This will cause flue gas spillage or appliance malfunction, resulting in possible severe personal injury, death or substantial property damage.

When removing boiler from an existing common vent system:

At the time of removal of an existing boiler, the following steps shall be followed with each appliance remaining connected to the common venting system placed in operation, while the other appliances remaining connected to the common venting system are not in operation.

- Seal any unused openings** in the common venting system.
- Visually inspect the venting system** for proper size and horizontal pitch and determine there is no blockage or restriction, leakage, corrosion or other deficiencies which could cause an unsafe condition.
- Test vent system** — Insofar as is practical, close all building doors and windows and all doors between the space in which the appliances remaining connected to the common venting system are located and other spaces of the building. Turn on clothes dryers and any appliance not connected to the common venting system. Turn on any exhaust fans, such as range hoods and bathroom exhausts, so they will operate at maximum speed. Do not operate a summer exhaust fan. Close fireplace dampers.
- Place in operation** the appliance being inspected. Follow the lighting/operating instructions. Adjust thermostat so appliance will operate continuously.
- Test for spillage** at draft hood relief opening after 5 minutes of main burner operation. Use the flame of a match or candle.
- After it has been determined that **each appliance** remaining connected to the common venting system properly vents when tested as outlined above, return doors, windows, exhaust fans, fireplace dampers, and any other gas-burning appliance to their previous conditions of use.

Any improper operation of common venting system should be corrected so the installation conforms with the National Fuel Gas Code, ANSI Z223.1-latest edition. Correct by resizing to approach the minimum size as determined using the appropriate tables in Part 11 of that code. Canadian installations must comply with B149.1 or B149.2 Installation Code.

CGs special vent system

Vent system

The CGs boiler requires a special vent system, designed for pressurized venting. Model CGs-3 is rated ANSI Z21.13 **Category IV** (pressurized vent, likely to condense in the vent). Models CGs-4, -5 and -6 are rated Z21.13 **Category III** (pressurized vent).

You may use any of the vent systems covered by the CGs Venting Supplements included in the envelope assembly. The CGs vent starter is a special item, designed only for the CGs boiler, available from each vendor. Do not attempt to connect the vent to the CGs boiler with any other means.

⚠ WARNING

DO NOT mix components from different systems. The vent system could fail, causing leakage of flue products into the living space.

Vent termination and combustion air supply

The CGs boiler may be vented through the roof or through a side wall. Follow the appropriate vent supplement for the vent system chosen. The maximum vent length depends on boiler size. Refer to the vent supplement to determine acceptable vent length.

Combustion air for the CGs boiler may be from inside or ducted directly to the boiler from outside. For outside air (direct vent installation), two options are available for the flue/air termination. The air supply must **ALWAYS** terminate at the same location as the flue, using either:

- Vertical direct vent installation.** Obtain the **Weil-McLain Through-Roof or Through-Unused Chimney** termination kit and supplement. Refer to **Vertical Direct Venting Venting Supplement**, packed with the kit, and to the vent manufacturer's instructions for the vent material chosen.
- Sidewall direct vent installation.** Use the **Vent/Air Intake** termination kit shipped with the boiler. Refer to **CGs Direct Venting: Sidewall & Direct Exhaust Venting: Vertical or Sidewall Venting Supplement** shipped with the boiler.



1d Prepare boiler location — contamination

Please review the following information on potential combustion air contamination problems.

Refer to **Table 1** for products and areas which may cause contaminated combustion air.

⚠ WARNING To prevent potential of severe personal injury or death, check for products or areas listed below before installing boiler. If any of these contaminants are found:

- remove contaminants permanently
- OR —
- isolate boiler and provide outside combustion air. See national, provincial or local codes for further information.

Table 1 Corrosive or destructive contaminants and likely locations

Products to avoid	Areas likely to have contaminants
Spray cans containing chloro/fluorocarbons	Dry cleaning/laundry areas and establishments
Permanent wave solutions	Swimming pools
Chlorinated waxes/cleaners	Metal fabrication plants
Chlorine-based swimming pool chemicals	Beauty shops
Calcium chloride used for thawing	Refrigeration repair shops
Sodium chloride used for water softening	Photo processing plants
Refrigerant leaks	Auto body shops
Paint or varnish removers	Plastic manufacturing plants
Hydrochloric acid/muriatic acid	Furniture refinishing areas and establishments
Cements and glues	New building construction
Antistatic fabric softeners used in clothes dryers	Remodeling areas
Chlorine-type bleaches, detergents, and cleaning solvents found in household laundry rooms	Garages with workshops
Adhesives used to fasten building products and other similar products	Buildings under construction (where air is contaminated with particulates)
Airborne particulates (drywall dust, fiberglass particles, road or gravel dust, lint, etc.)	

⚠ WARNING **CONSTRUCTION DUST HAZARD** — Airborne particulates, such as drywall dust or fiberglass dust, will cause blockage of the CGi burners, resulting in carbon monoxide production, a fire hazard, or building freeze damage. If the boiler is operated during construction, you must isolate the boiler air supply to provide clean air for combustion. Follow the instruction manual guidelines for piping intake air. **If you are unable to ensure uncontaminated air in the boiler air intake at all times, you must inspect the boiler at least once weekly.** When inspecting, clean the burners if necessary using the procedure given on page 39. Failure to follow these guidelines could result in severe personal injury, death or substantial property damage.



1e Prepare boiler location — air openings

▲WARNING



Combustion air opening location and sizing requirements depend on the clearances around the boiler. Check the boiler placement compared to Figure 1, page 7.

If all clearances are at least equal to Figure 1, page 7, apply the sizing and placement of openings given on pages 10 and 11.

If ANY clearance is less than Figure 1, page 7, you must provide air openings sized and located as shown in Figure 2, page 7. **DO NOT** apply the sizing and location information shown on page 10 or 11. The Figure 2 air openings are required even if the boiler is direct vented (outside air piped to the boiler air intake as described in this manual). These openings ensure adequate air circulation around the boiler for cooling, even if the boiler does not use inside air for combustion.

mended in Figure 3 will allow adequate ventilation and combustion air provided the boiler room is not subjected to negative pressure due to exhaust fans or other mechanical ventilation devices. Refer to the National Fuel Gas Code for dealing with other conditions.

Louver allowance

The free area of openings means the area **after reduction for any installed louvers or grilles.** Be sure to consider this reduction when sizing the air openings.

Special considerations

Tight construction

ANSI Z223.1 defines unusually tight construction where:

1. Walls and ceilings exposed to the outside atmosphere have a continuous water vapor retarder with a rating of 1 perm or less with openings gasketed, and . . .
2. Weather-stripping has been added on openable windows and doors, and . . .
3. Caulking or sealants are applied to areas such as joints around windows and door frames, between sole plates and floors, between wall-ceiling joints, between wall panels, at penetrations for plumbing, electrical, and gas lines, and in other openings.

For buildings with such construction, provide air openings into the building from outside, sized per the appropriate case in **Figure 3** if appliances are to use inside air for combustion and ventilation.

Exhaust fans and air movers

The appliance space must never be under a negative pressure unless all appliances are installed as direct vent. Always provide air openings sized not only to the dimensions required for the firing rate of all appliances, but also to handle the air movement rate of the exhaust fans or air movers using air from the building or space.

Motorized air dampers

If the air openings are fitted with motorized dampers, electrically interlock the damper to:

- Prevent the boiler from firing if the damper is not fully open.
- Shut the boiler down should the damper close during boiler operation.

To accomplish this interlock, wire an **isolated contact** (proving the damper open) in series with the thermostat input to the boiler. The boiler will not start if this contact is open, and will shut down should it open during operation.

Combustion air options ★

Using inside air — direct exhaust vent

The CGs boiler can use inside air if no contaminants are present in the boiler space. If contaminants are likely to be present, install the CGs boiler as a direct vent appliance, using the appropriate vent supplement and the instructions in this manual.

Using outside air — direct vent

Combustion air can be ducted directly from outside to the CGs boiler air intake fitting. This method is defined as **direct vent** (also referred to as sealed combustion). Refer to the appropriate vent supplement and the instructions in this manual. Two options are available: sidewall or vertical direct vent. Each requires a special vent component kit.

Sizing air openings ★

Air openings provide for ventilation (as well as combustion air) to prevent overheating of the boiler controls and boiler space. Air is also needed for other appliances located in the same space.

Use **Figure 3**, page 11, selecting the appropriate installation conditions. Note that the sizing given in Figure 3 applies only to CGs installations with clearances no smaller than shown in **Figure 1**, page 7 of this manual. For smaller clearances, regardless of how the air openings are arranged, two openings providing free area of 1 square inch per 1,000 Btuh input of all appliances in the space are required.

NOTICE

Air openings must be sized to handle all appliances and air movers (exhaust fans, etc.) using the air supply.

The sizing given in Figure 3 is based on the National Fuel Gas Code, ANSI Z223.1, allowing adequate air opening for gravity-vented gas appliances (Category I). The CGs boiler is rated Category III or IV (pressurized vent), and has different requirements for combustion and ventilation air, reflected by the special sizing instructions given in Figure 3. The air openings recom-

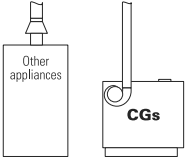
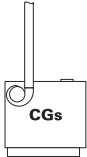
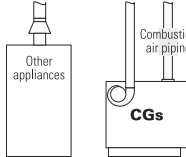
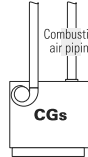
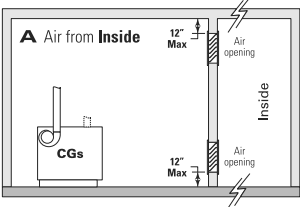
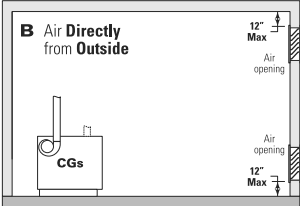
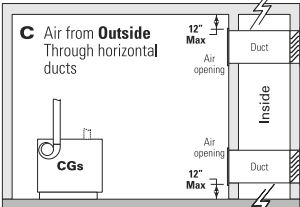
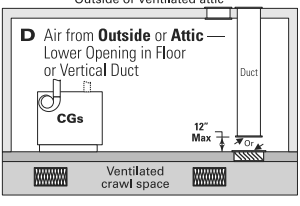

Figure 3 Sizing air openings for CGs installations ★

Room Air Openings Required area of the air openings given in this table are free area — after the correction for louver obstruction. (Note EXCEPTION below.) ⓐ Apply this table only to installations with clearances no smaller than those shown in Figure 1, page 7 of this manual. ⓑ For multiple-appliance installations with clearances less than shown in Figure 1, page 7 of this manual, provide 2 openings, each with 1 square inch of free area per 1,000 Btuh of total input of all appliances. Locate openings as shown in Figure 2, page 7.	Direct exhaust vent installation ⓐ (CGs using room air for combustion)		Direct vent installation ⓐ (combustion air piped to CGs)	
	 Room shared with other appliances	 CGs alone in room	 Room shared with other appliances	 CGs alone in room
 <p>A Air from Inside</p>	<p>2 Openings — each with 1 square inch per 1,000 Btuh input of other appliances PLUS the CGs</p>	<p>2 Openings — each with 1 square inch per 4,000 Btuh input of the CGs</p>	<p>2 Openings — each with 1 square inch per 1,000 Btuh input of all appliances except the CGs</p>	<p>NO Openings are needed, provided:</p> <p>Clearance around boiler must be NO LESS than shown in Figure 1, page 7 of this manual.</p>
 <p>B Air Directly from Outside</p>	<p>2 Openings — each with 1 square inch per 4,000 Btuh input of other appliances PLUS the CGs</p> <p>– OR –</p> <p>1 Opening — with 1 square inch per 3,000 Btuh input of other appliances PLUS the CGs (See NOTICE below)</p>	<p>2 Openings — each with 1 square inch per 4,000 Btuh input of the CGs</p> <p>– OR –</p> <p>1 Opening — with 1 square inch per 4,000 Btuh input of the CGs (See NOTICE below)</p>	<p>2 Openings — each with 1 square inch per 4,000 Btuh input of all appliances except the CGs</p> <p>– OR –</p> <p>1 Opening — with 1 square inch per 3,000 Btuh input of all appliances except the CGs (See NOTICE below)</p>	<p>NO Openings are needed, provided:</p> <p>Clearance around boiler must be NO LESS than shown in Figure 1, page 7 of this manual.</p>
 <p>C Air from Outside Through horizontal ducts</p>	<p>2 Openings — each with 1 square inch per 2,000 Btuh input of other appliances PLUS the CGs</p> <p>– OR –</p> <p>1 Opening — with 1 square inch per 3,000 Btuh input of other appliances PLUS the CGs (See NOTICE below)</p>	<p>2 Openings — each with 1 square inch per 4,000 Btuh input of the CGs</p> <p>– OR –</p> <p>1 Opening — with 1 square inch per 4,000 Btuh input of the CGs (See NOTICE below)</p>	<p>2 Openings — each with 1 square inch per 2,000 Btuh input of all appliances except the CGs</p> <p>– OR –</p> <p>1 Opening — with 1 square inch per 3,000 Btuh input of all appliances except the CGs (See NOTICE below)</p>	<p>NO Openings are needed, provided:</p> <p>Clearance around boiler must be NO LESS than shown in Figure 1, page 7 of this manual.</p>
 <p>D Air from Outside or Attic — Lower Opening in Floor or Vertical Duct</p>	<p>2 Openings — each with 1 square inch per 4,000 Btuh input of other appliances PLUS the CGs</p> <p>– OR –</p> <p>1 Opening — with 1 square inch per 3,000 Btuh input of other appliances PLUS the CGs (See NOTICE below)</p>	<p>2 Openings — each with 1 square inch per 4,000 Btuh input of the CGs</p> <p>– OR –</p> <p>1 Opening — with 1 square inch per 4,000 Btuh input of the CGs (See NOTICE below)</p>	<p>2 Openings — each with 1 square inch per 4,000 Btuh input of all appliances except the CGs</p> <p>– OR –</p> <p>1 Opening — with 1 square inch per 3,000 Btuh input of all appliances except the CGs (See NOTICE below)</p>	<p>NO Openings are needed, provided:</p> <p>Clearance around boiler must be NO LESS than shown in Figure 1, page 7 of this manual.</p>
<p>NOTICE: Requirements for using the single air opening option —</p>	<p>A single combustion air opening can be used for case B, C or D installations above, sized as directed, provided that the CGs boiler has clearances of at least those shown in Figure 1, page 7, and . . .</p> <ul style="list-style-type: none"> • The single opening must communicate directly to the outdoors or to a space that communicates directly to the outdoors (not to an interior space). • The top of the opening must be within 12 inches of the ceiling. • The free area of the opening must be at least equal to the sum of the areas of all equipment vent connectors in the space. 			
<p>SPECIAL EXCEPTION: Combustion air provision rules for large spaces —</p>	<p>NO combustion air openings are needed when the boiler (and other appliances) are installed in a space with a volume NO LESS than 50 cubic feet per 1,000 Btuh of all installed appliances. Sum the total input of all appliances in MBH (1,000's of Btuh) and multiply this number times 50. Building must not be of Tight construction (see page 10).</p> <p>Example: For total input of 100 MBH (100,000 Btuh), minimum volume is 50 x 100 = 5,000 cubic feet. At a ceiling height of 8 feet, space must have at least 5,000 ÷ 8 = 625 square feet (25 feet x 25 feet, for instance).</p>			

26007



2a Prepare boiler — placement & setup

Place boiler/crate near position

1. Leave boiler in crate and on pallet until installation site is ready.
2. Move entire crate and pallet next to selected location.
3. Remove crate.
4. Remove boiler from pallet.

- NOTICE** Do not drop boiler or bump jacket on floor or pallet. Damage to boiler can result.
- a. Tilt left side of boiler up and place a board under left legs.
 - b. Tilt boiler the other way and place a board under right legs.
 - c. Slide boiler backward off pallet and into position.
5. Check level.
 - a. Shim legs, if necessary.
 - b. Do not alter legs.

Inspect orifices and burners

1. Remove front jacket door. Remove inlet air box top panel (see Figure 27, item 13, page 56).
2. Check for correctly-sized manifold orifices. See Table 2 for sizing. (The orifice size is stamped on the orifice spud barrel.)

DANGER Correctly-sized manifold orifices must be used. Failure to do so will result in severe personal injury, death or substantial property damage.

3. Reinstall inlet air box top panel.



Inlet air box top panel must be in position during boiler operation. Failure to do so could result in severe personal injury, death or substantial property damage.

Orifice replacement procedure (when required)

1. Remove the screws securing the inlet air box top panel.
2. Remove inlet air box top panel and inspect the fiber gasket. Verify the gasket is in good condition and can seal around the complete perimeter of the air box. Replace the gasket if necessary.
3. Using a 7/16" open-end wrench, remove the burner orifices from the manifold.
4. Apply a small amount of pipe dope to each of the new orifices and install in the manifold using a 7/16" open-end wrench. Make sure the orifices are aligned correctly, not cross-threaded in the manifold tapings.



Use only pipe dope compatible with propane gas, even if boiler is to be operated on natural gas. Failure to comply could result in severe personal injury, death or substantial property damage.

5. Carefully replace the inlet air box top panel, making sure the gasket is in place will seal all around the perimeter.
6. Follow the check-out procedure, Section 8 page 30, to assure the boiler is now operating properly after orifices are replaced.

Table 2 Manifold orifice sizing

Location	Natural gas		Propane gas	
	0-2,000 ft	over 2,000 ft	0-2,000 ft	over 2,000 ft
U. S.	2.70 mm	(Note 1)	1.65 mm	(Note 1)
Canada	2.70 mm	2,000-4,500 #38	1.65 mm	2,000-4,500 #53

Note 1: For elevations above 2,000 feet, contact your local Weil-McLain sales office for details.



2b Prepare boiler — pressure test

Hydrostatic pressure test

Pressure test boiler **before** attaching water or gas piping (except as noted below) or electrical supply.

Prepare boiler for test

1. Remove the shipping nipple (from CGs supply tapping) and remove the boiler relief valve. Temporarily plug the relief valve tapping with a 3/4" NPT pipe plug.
2. Remove 1/4" nipple, reducing tee and drain valve from circulator hardware and pressure/temperature gauge carton. Install in boiler return connection as shown on page 3 and Figure 29, page 58. Install circulator on either the return or supply.
3. Remove 1/4" nipple, 1/4" x 1/4" x 1/2" tee and pressure/temperature gauge from circulator hardware and pressure/temperature gauge carton. Pipe to boiler supply connection as shown on page 3 and Figure 29, page 58. (Use pipe dope sparingly.)
4. Connect a hose to boiler drain valve, the other end connected to a fresh water supply. Make sure hose can also be used to drain boiler after test.
5. Connect a nipple and shutoff valve to system supply connection on the 1/4" tee. This valve will be used to bleed air during the fill. (Valve and nipple are not included with boiler.)
6. Connect a nipple and shutoff valve to system return connection (at circulator flange if circulator installed on return). This valve will be used to bleed air during the fill. (Valve and nipple are not included with boiler.)

Fill and pressure test

1. Open the shutoff valves you installed on supply and return connections.
2. Slowly open boiler drain valve and fresh water supply to fill boiler with water.
3. When water flows from shutoff valves, close boiler drain valve.
4. Close shutoff valves.

5. Slowly reopen boiler drain valve until test pressure on the pressure/temperature gauge reaches no more than:

- 45 psig for boilers with 30 psig relief valve.
- 75 psig for boilers with 50 psig relief valve.

6. Test for no more than 10 minutes at:

- 45 psig for boilers with 30 psig relief valve.
- 75 psig for boilers with 50 psig relief valve.



Do not leave boiler unattended. A cold water fill could expand and cause excessive pressure, resulting in severe personal injury, death or substantial property damage.

7. Make sure constant gauge pressure has been maintained throughout test. Check for leaks. Repair if found.



Leaks must be repaired at once. Failure to do so can damage boiler, resulting in substantial property damage.



Do not use petroleum-based cleaning or sealing compounds in boiler system. Severe damage to boiler will occur, resulting in substantial property damage.

Drain and remove fittings

1. Disconnect fill water hose from water source.
2. Drain boiler at drain valve or out hose, whichever provides best access to drain. Remove hose after draining if used to drain boiler.
3. Remove nipples and valves unless they will remain for use in the system piping.
4. Remove plug from relief valve tapping. See page 14 to replace relief valve.



3a Water piping — general information

General piping information

If installation is to comply with ASME or Canadian requirements, an additional **high temperature limit** is needed. Install control in supply piping between boiler and isolation valve. Set second control to minimum 20°F above setpoint of first control. Maximum allowable setpoint is 240°F. See Section 9b, page 32 for wiring.

A **low water cutoff device** is required when boiler is installed above radiation level or by certain state or local codes or insurance companies. Use low water cutoff designed for water installations. Electrode probe-type is recommended. Purchase and install in tee in supply piping above boiler.

Use **backflow check valve** in cold water supply as required by local codes.

Pressure/temperature gauge

Install pressure/temperature gauge in tee on supply piping (as shown in drawing on page 3).

Relief valve

Install relief valve vertically in 3/4" tapping on side of boiler. See Figure 4 or 5, page 15, and the tag attached to the relief valve for manufacturer's instructions.

⚠️ WARNING

To avoid water damage or scalding due to relief valve operation:

- Discharge line must be connected to relief valve outlet and **run to a safe place of disposal**. Terminate the discharge line to eliminate possibility of severe burns should the valve discharge.
- Discharge line must be as short as possible and be the **same size as the valve discharge connection** throughout its entire length.
- Discharge line must **pitch downward** from the valve and terminate at least 6" above the floor drain where any discharge will be clearly visible.
- The discharge line shall **terminate plain, not threaded**, with a material serviceable for temperatures of 375°F or greater.
- **Do not pipe the discharge to any place where freezing could occur.**
- **No shutoff valve** shall be installed between the relief valve and boiler, or in the discharge line. Do not plug or place any obstruction in the discharge line.
- **Failure to comply** with the above guidelines could result in failure of the relief valve to operate, resulting in possibility of severe personal injury, death or substantial property damage.
- **Test the operation of the valve** after filling and pressurizing system by lifting the lever. Make sure the valve discharges freely. If the valve fails to operate correctly, replace it with a new relief valve.

Circulator

The circulator is shipped loose (wiring pre-attached to boiler) to allow you to locate it either in the return or supply piping, as desired. See page 3 for a typical installation. Pipe the expansion tank to the suction side of the circulator whenever possible. Install an air separator in the supply piping. Connect the expansion tank to the air separator only if the separator is on the suction side of the circulator. Always install the system fill connection at the same point as the expansion tank connection to the system. Figures 4 and 5, page 15, show typical near-boiler piping connections.

System water piping

See Figure 4 (diaphragm-type or bladder-type expansion tank) or Figure 5 (closed-type expansion tank) on page 15, and Table 3 below, for near-boiler and single-zone systems designed for return water at least 130°F.

See pages 16-17 to complete multiple-zone piping or pages 18-23 to complete piping for radiant heating systems or converted gravity systems (large-volume systems originally designed for circulation by natural convection rather than a pump).

Table 3 Water pipe size (based on 20°F rise)

Boiler model number	To system	From system
CGs-3/4/5	1"	1"
CGs-6	1 1/4"	1 1/4"

Note: The boiler supply and return connections, the return/drain tee and the supply/gauge tee supplied with the boiler are 1 1/4" NPT. One of the circulator flanges supplied with the boiler is 1 1/4". The other circulator flange is the size of the recommended system piping shown above.

⚠️ WARNING

Chillers or air handling units:
Install boiler such that —

- Chilled medium, if used, is piped in parallel with heating boiler. Use appropriate valves to prevent chilled medium from entering boiler. Consult I=B=R Installation and Piping Guides.
- If boiler is connected to heating coils located in air handling units where they can be exposed to refrigerated air, use flow control valves or other automatic means to prevent gravity circulation during cooling cycle. Circulation of cold water through the boiler could result in damage to the heat exchanger, causing possible severe personal injury, death or substantial property damage.



3b Water piping — single-zone system

Diaphragm-type or bladder-type expansion tank (Figure 4)

1. Ensure expansion tank size will handle boiler and system water volume and temperature. Tank must be located in boiler return piping as close to boiler as possible, before inlet side of circulator. See tank manufacturer's instructions for details.
2. Install an automatic air vent in air vent tapping as shown.

Closed-type expansion tank (Figure 5)

1. Ensure expansion tank size will handle boiler and system water volume and temperature. See tank manufacturer's instructions for details.
2. Connect tank to 1/2" NPT tapping located behind supply outlet, using 1/2" NPT piping. Pitch any horizontal piping up towards tank 1 inch per 5 feet of piping.



Undersized expansion tanks cause system water to be lost from relief valve and makeup water to be added through fill valve. Eventual section failure can result.



Use Figure 4 or Figure 5 only for single-zone systems designed for return water at least 130°F. For systems with low return water temperature possible, such as converted gravity systems and radiant heating systems, refer to the special piping suggestions of pages 18-23. Failure to prevent low return water temperature to the boiler could cause corrosion of the boiler sections or burners, resulting in severe personal injury, death or substantial property damage.

Figure 4 Diaphragm- or bladder-type expansion tank Piping to single-zone system See Table 3 for piping sizes.

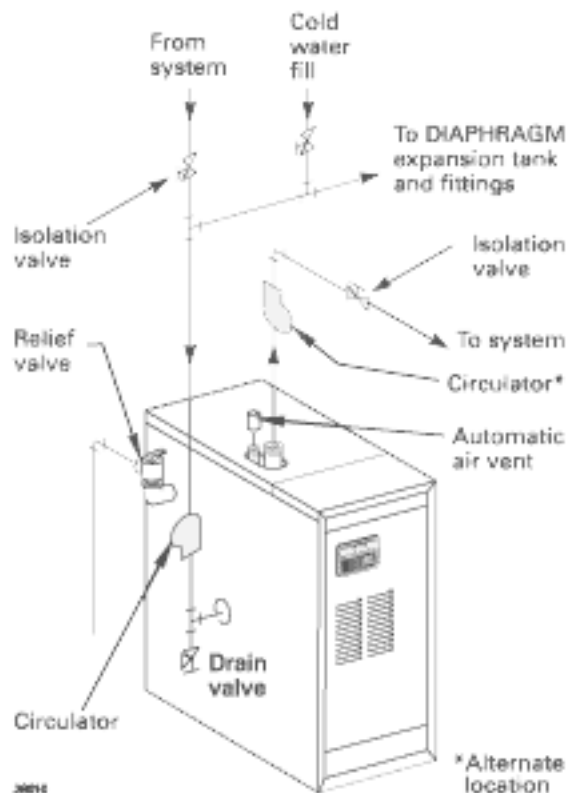
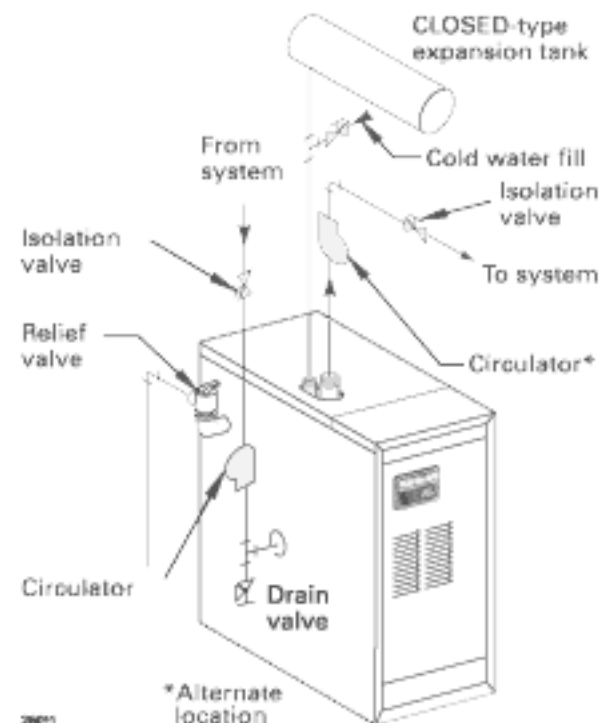

Figure 5 Closed-type expansion tank Piping to single-zone system See Table 3 for piping sizes.





3C Water piping — multiple zones

Piping multiple zones

Follow instructions on pages 14 and 15 to install near-boiler or single-zone piping. (Also refer to **Piping for radiant heating systems or converted gravity systems**, below, if applicable.)

See **Figure 6** or **Figure 7**, page 17, to complete installation.

Zoning with circulators (Figure 6) (return temp over 130°F)

1. Size each circulator to individual circuit requirements.
2. Do not install circulator on boiler (except for primary/secondary piping).
3. Install isolation (balancing) valves to adjust flow to distribute heat to all zones.
4. Install and wire a separate relay for each zone circulator.

Zoning with zone valves (Figure 7) (return temp over 130°F)

1. Install isolation (balancing) valves to adjust flow to distribute heat to all zones.
2. Provide a separate 24-volt transformer to power the zone valves. Size the transformer to handle the total rated load of all connected zone valves.

Piping for radiant heating systems or converted gravity systems

Converted gravity (or steam) systems

Whenever possible, use the primary/secondary piping shown in **Figures 8** or **9** on page 19. This piping design allows changing boiler flow rate without affecting primary circuit flow rate.

If **Figures 8** or **9** cannot be used, use the boiler-bypass piping shown in **Figure 10** or **Figure 11** on page 21. You can also use the piping shown in **Figure 12** on page 23 (system-bypass), if the reduced flow rate in the heating system will not cause heat distribution problems.

⚠ WARNING

Failure to prevent low return water temperature to the boiler could cause corrosion of the boiler sections or burners, resulting in severe personal injury, death or substantial property damage.

Radiant heating systems

Preferably, use primary/secondary piping, as shown in **Figures 8** or **9** on page 19. Alternatively, use the method of either **Figure 10** or **Figure 11** on page 21. **Do not use the piping of Figure 12** (system-bypass), because this method does not control radiant system supply temperature.

If radiant system tubing has no oxygen barrier, a **heat exchanger** must be used.

⚠ WARNING

Radiant heating system piping should include a means of regulating the boiler return water temperature and the system supply temperature (such as provided by an injection pumping control). Boiler return water temperature will be adequately controlled using the methods shown in this manual provided the system supply temperature is relatively constant.

DO NOT apply the methods in this manual if the system is equipped with an **outdoor reset control**. Instead, provide controls and piping which can regulate the boiler return water temperature at no less than 130°F regardless of system supply temperature. Contact your Weil-McLain representative for suggested piping and control methods. Failure to prevent cold return water temperature to the boiler could cause corrosion damage to the sections or burners, resulting in possible severe personal injury, death or substantial property damage.



3C Water piping — multiple zones (continued)

Figure 6 Zoning with circulators
— return water 130°F or higher.

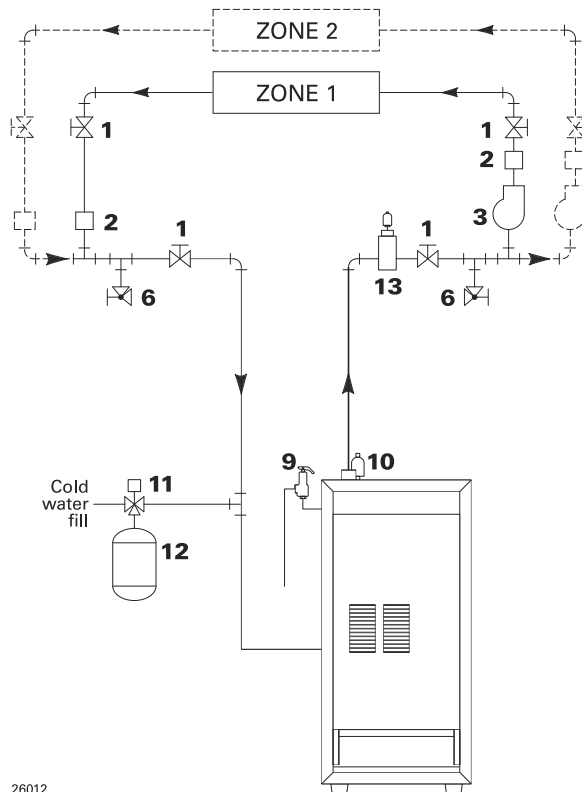

26012

Figure 7 Zoning with zone valves
— return water 130°F or higher.

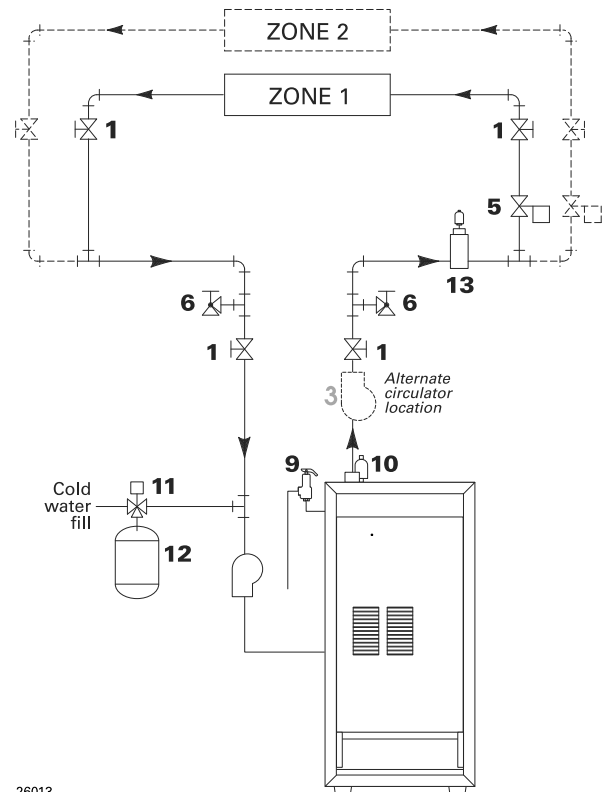

26013

- 1 Boiler isolation (balancing) valves
- 2 Flow/check valve
- 3 System or zone circulator
- 5 Zone valve
- 6 Drain valve
- 9 Relief valve
- 10 Automatic air vent (with diaphragm-type expansion tank), or connect to tank fitting (closed-type expansion tank). **DO NOT** use an automatic air vent when using closed-type expansion tank. It would allow air to leave the system, causing waterlogging of the expansion tank.
- 11 Fill valve
- 12 Diaphragm-type or bladder-type expansion tank, if used (For closed-type expansion tank, pipe from top of air separator to tank fitting as in Figure 5, page 15.)
- 13 Air separator and automatic vent, if used (Note that the fill valve must always be connected to the expansion tank, regardless of location of expansion tank circulator or air separator.)

▲ WARNING

For systems with possible low return-water temperature (such as converted gravity systems, radiant heating systems and heat pump systems), refer to the special piping suggestions of Figures 8 - 12, as applies. Failure to prevent sustained low return water temperature to the boiler could cause corrosion of the boiler sections, resulting in severe personal injury, death or substantial property damage.



3d Piping — low temp systems

Primary/secondary (preferred) bypass piping method

Primary/secondary bypass piping is preferred because the flow rate and temperature drop in the heating circuit(s) is determined only by the heating circuit circulator(s). So adjustment of the bypass valves in the boiler circuit will not cause a change in the heating circuit rate and temperature distribution.

Figures 8 and 9, page 19, show suggested bypass arrangements using primary/secondary bypass piping (preferred) for low temperature systems such as radiant heating systems or converted gravity systems. For alternatives, see pages 20 through 23.

The bypass valves in Figures 8 and 9 (items 7a and 7b) provide mixing of hot boiler outlet water with cooler system return water — set to assure a minimum return water temperature (at least 130°F) to the boiler. Set the valves as explained below.

Temperature gauges

Gauge 4a is suggested, but optional on any system.

Gauge 4b is optional on converted gravity systems, but required on radiant heating systems — to display

the water temperature being supplied to the radiant tubing.

Gauge 8 is required on all systems to assure the return water temperature is accurately set for a minimum of 130°F. If this gauge is not available however, adjust the valves such that the boiler-mounted temperature/pressure gauge reads at least 150°F when the system return water is cold (approximately 60°F water temperature).

Valve adjustment (Figures 8 and 9 only)

1. Set the valves while the system is cool, setting for the coldest expected water temperature (usually 60°F since the system will often drop to room temperature between cycles).
2. Start with valve 7a fully closed and 7b fully open.
3. Gradually open valve 7a while closing valve 7b until the temperature at gauge 8 reads 130°F when gauge 4a reads 60°F.
4. Note that valve 7a regulates the amount of hot water from the boiler supply which mixes with return water. Valve 7b regulates the amount of system water flowing through the boiler secondary loop.

WARNING

Failure to **prevent low return water temperature** to the boiler could cause corrosion of the boiler sections or burners, resulting in severe personal injury, death or substantial property damage.

Radiant heating system piping should include a means of **regulating the boiler return water temperature** and the **system supply temperature** (such as provided by an **injection pumping control**).

Boiler return water temperature will be adequately controlled using the methods shown in this manual provided the **system supply temperature** is **relatively constant**.

DO NOT apply the methods of this manual if the system is equipped with an **outdoor reset control**. Instead, **provide controls and piping** which can **regulate the boiler return water temperature** at **no less than 130°F** regardless of system supply temperature. Contact your Weil-McLain representative for suggested piping and control methods.

Failure to **prevent cold return water temperature** to the boiler could cause corrosion damage to the sections or burners, resulting in possible severe personal injury, death or substantial property damage.



3d Piping — low temp systems (continued)

Figure 8 Primary/secondary piping Zoning with circulators

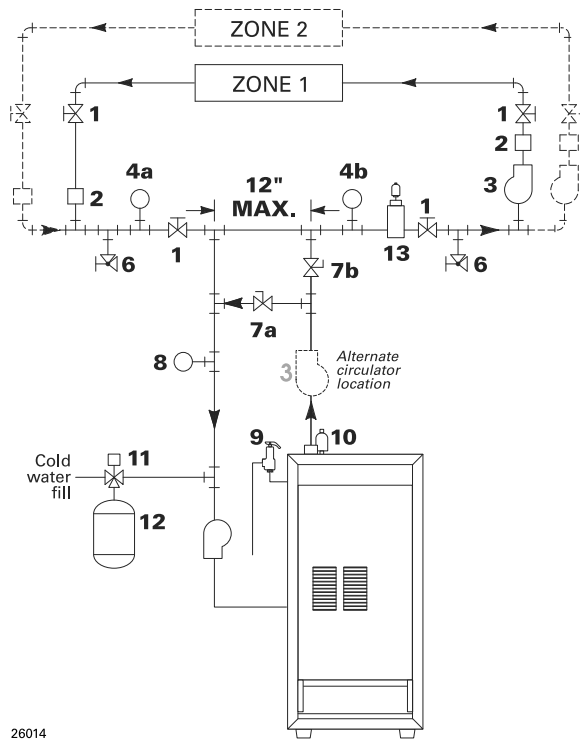

26014

Figure 9 Primary/secondary piping Zoning with zone valves

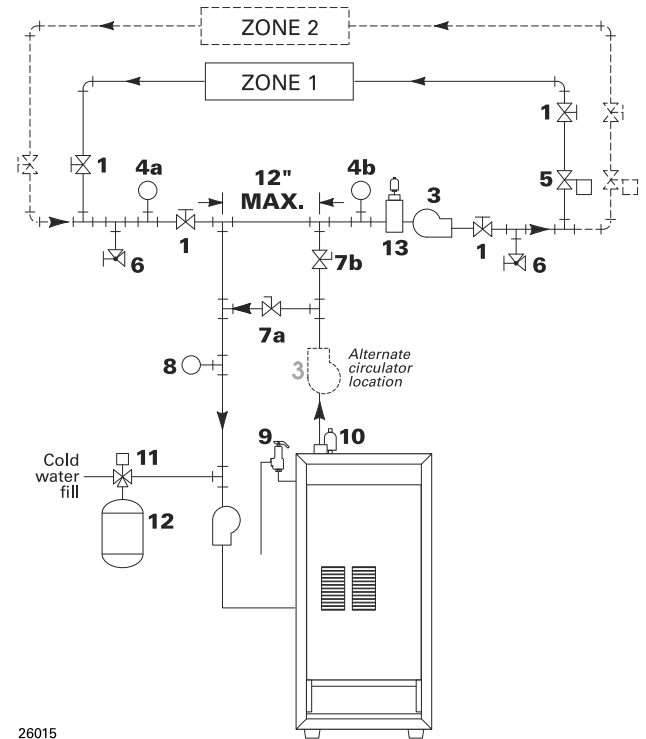

26015

- 1 Boiler isolation (balancing) valves
- 2 Flow/check valve
- 3 System or zone circulator
- 4 System temperature gauges
- 5 Zone valve
- 6 Drain valve
- 7 System temperature valves (see instructions to the left for adjusting valves)
- 8 Blend temperature gauge

- 9 Relief valve
- 10 Automatic air vent (with diaphragm-type expansion tank), or connect to tank fitting (closed-type expansion tank). **DO NOT** use an automatic air vent when using closed-type expansion tank. It would allow air to leave the system, causing waterlogging of the expansion tank.
- 11 Fill valve
- 12 Diaphragm-type or bladder-type expansion tank, if used (For closed-type expansion tank, pipe from top of air separator to tank fitting as in Figure 5, page 15.)
- 13 Air separator and automatic vent, if used (Note that the fill valve must always be connected to the expansion tank, regardless of location of expansion tank, circulator or air separator.)



3d Piping — low temp systems (continued)

BOILER-bypass piping method

This piping method (Figures 10 and 11, page 21) is called a **boiler-bypass** because part of the circulator flow is bypassed around the boiler (through valve 7a). This method reduces the flow rate throughout the boiler, in order to raise the average water temperature in the boiler enough to prevent flue gas condensation. Boiler-bypass piping is effective for some boilers — including the CGs — provided the flow rates are adjusted according to the instructions following.

Figures 10 and 11 are alternative piping suggestions for **converted gravity** (large water content or steam systems) or **radiant heating system** — for use when primary/secondary piping can't be applied. (Figure 12, page 23, is another alternative, using system bypass in place of boiler-bypass piping. Figure 12 however, is not suitable for radiant heating applications because it does not protect the radiant system from possible high water temperature.)

Boiler-bypass piping keeps system flow rate as high as possible and temperature drop as low as possible, helping to equalize the building heat distribution.

Temperature gauges

Gauge 4a is optional if the bypass valves will be ad-

justed using cold (or room temperature) return water to the boiler. (When setting the valves without gauge 4a installed — using cold or room temperature water — assume the return water temperature to be 60°F. Set the valves so gauge 8 reads at least 120°F.

Gauge 4b is optional on converted gravity systems, but **required** on radiant heating systems — to display the water temperature being supplied to the radiant tubing.

Gauge 8 is **required** on all systems to assure reliable adjustment of the bypass valves. The boiler-mounted temperature/pressure gauge can be used if a separate temperature gauge is not installed.

Valve adjustment

1. Start with valve 7a fully closed and 7b fully open.
2. Gradually open valve 7a while closing valve 7b until the temperature at gauge 8 reads 60 °F higher than gauge 4a. A minimum 60°F temperature rise through the boiler assures a low enough flow rate and high enough average temperature to prevent condensation even with low system return water temperature.
3. Valve 7a regulates the system flow rate, while valve 7b regulates the boiler flow rate.
4. The boiler-mounted temperature/pressure gauge may be used in place of a separate gauge 8.

WARNING

Failure to **prevent low return water temperature** to the boiler could cause corrosion of the boiler sections or burners, resulting in severe personal injury, death or substantial property damage.

Radiant heating system piping should include a means of **regulating the boiler return water temperature** and the **system supply temperature** (such as provided by an **injection pumping control**).

Boiler return water temperature will be adequately controlled using the methods shown in this manual provided the **system supply temperature** is **relatively constant**.

DO NOT apply the methods of this manual if the system is equipped with an **outdoor reset control**. Instead, **provide controls and piping** which can **regulate the boiler return water temperature** at **no less than 130°F** regardless of system supply temperature. Contact your Weil-McLain representative for suggested piping and control methods.

Failure to **prevent cold return water temperature** to the boiler could cause corrosion damage to the sections or burners, resulting in possible severe personal injury, death or substantial property damage.



3d Piping — low temp systems (continued)

Figure 10 Boiler-bypass piping
Zoning with circulators
Alternative to primary/secondary piping
Figures 8 and 9)

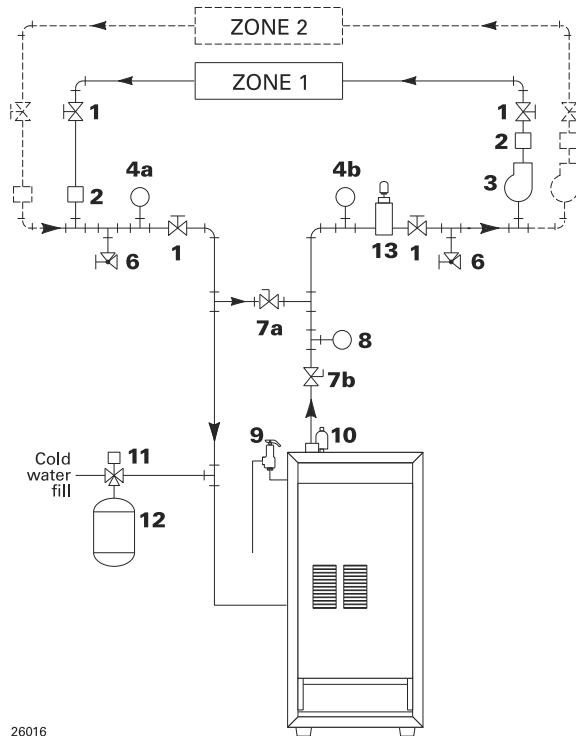

26016

Figure 11 Boiler-bypass piping
Zoning with zone valves
(Alternative to primary/secondary piping
Figures 8 and 9)

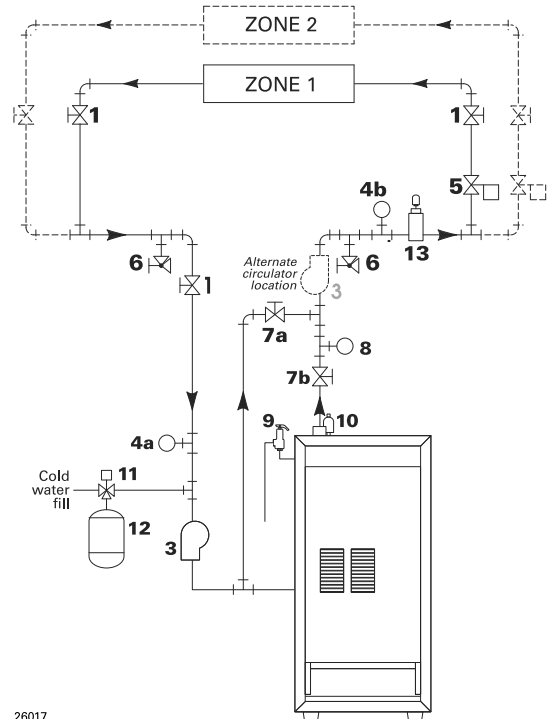

26017

- 1 Boiler isolation (balancing) valves
- 2 Flow/check valve
- 3 System or zone circulator
- 4 System temperature gauges
- 5 Zone valve
- 6 Drain valve
- 7 System temperature valves (see instructions to the left for adjusting valves)
- 8 Blend temperature gauge
- 9 Relief valve

- 10 Automatic air vent (with diaphragm-type expansion tank), or connect to tank fitting (closed-type expansion tank). **DO NOT** use an automatic air vent when using closed-type expansion tank. It would allow air to leave the system, causing waterlogging of the expansion tank.
- 11 Fill valve
- 12 Diaphragm-type or bladder-type expansion tank, if used (For closed-type expansion tank, pipe from top of air separator to tank fitting as in Figure 5, page 15.)
- 13 Air separator and automatic vent, if used (Note that the fill valve must always be connected to the expansion tank, regardless of location of expansion tank, circulator or air separator.)



3d Piping — low temp systems (continued)

SYSTEM-bypass piping method

This piping method (Figure 12, page 23) is called a **system-bypass** because part of the circulator flow bypasses the system (through valve 7a). This bypassed hot water from the boiler outlet mixes with cooler system return water temperature in order to provide minimum 130°F return water to the boiler. Valve 7b will most often be full open, but may need to be slightly closed on some low pressure drop systems in order to cause enough flow through valve 7a.

Figure 12 is an alternative piping method that provides return water temperature control for boilers installed on **converted gravity systems** (large water content or steam systems).

Do not apply the piping of Figure 12 on **radiant heating systems**. It provides no method regulating the water temperature provided to the system and could result in excessive water temperature in the radiant tubing.

System-bypass piping as shown in Figure 12 can be used with either zone valve or circulator zoning. When used with circulator zoning however, the boiler circulator

(item 3), must be piped as shown. It cannot be used as one of the zoning circulators.

Do not apply system-bypass piping if the reduced flow in the system could cause poor heat distribution. That is, system-bypass piping reduces the flow in the system and increases the water temperature supplied to the system. This can cause increased heat from radiators at the beginning of the system and reduced heat from radiators near the end of the system.

Valve adjustment

1. Start with valve 7a fully closed and 7b fully open.
2. Gradually open valve 7a while closing valve 7b until the temperature at gauge 8 reads at least 130°F at all times.
3. Valve 7a regulates the amount of boiler supply water mixed with return water. Valve 7b causes a pressure drop in the system needed to balance flow through valve 7a and the system.
4. The valve adjustment should be done with the system at the coldest expected temperature (60°F for converted gravity systems or high mass radiant systems).

WARNING

Failure to **prevent low return water temperature** to the boiler could cause corrosion of the boiler sections or burners, resulting in severe personal injury, death or substantial property damage.

Radiant heating system piping should include a means of **regulating the boiler return water temperature** and the **system supply temperature** (such as provided by an **injection pumping control**).

Boiler return water temperature will be adequately controlled using the methods shown in this manual provided the **system supply temperature** is **relatively constant**.

DO NOT apply the methods of this manual if the system is equipped with an **outdoor reset control**. Instead, **provide controls and piping** which can **regulate the boiler return water temperature** at **no less than 130°F** regardless of system supply temperature. Contact your Weil-McLain representative for suggested piping and control methods.

Failure to **prevent cold return water temperature** to the boiler could cause corrosion damage to the sections or burners, resulting in possible severe personal injury, death or substantial property damage.



3d Piping — low temp systems (continued)

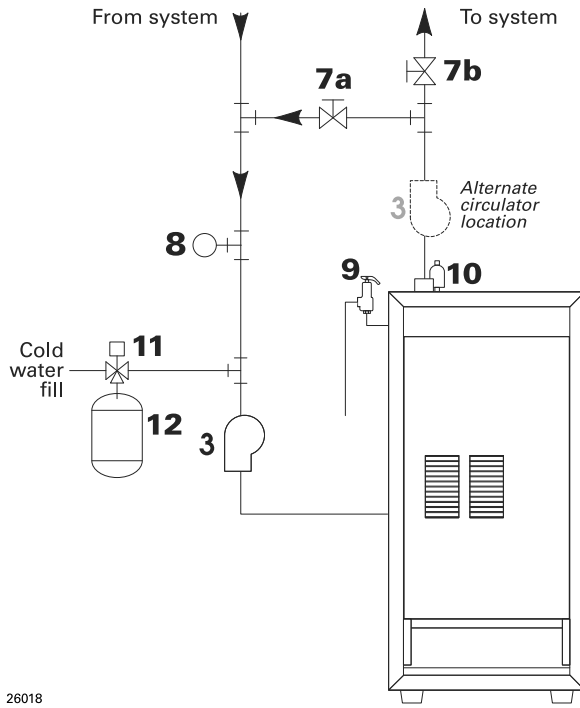

26018

Figure 12 System-bypass piping
Zoning with zone valve or circulators, return water 130°F or higher.
(Alternative to boiler-bypass piping Figures 10 and 11, page 21)

- 3 System or zone circulator
- 7 System temperature valves (see instructions to the left for adjusting valves)
- 8 Blend temperature gauge
- 9 Relief valve
- 10 Automatic air vent (with diaphragm-type expansion tank), or connect to tank fitting (closed-type expansion tank). **DO NOT** use an automatic air vent when using closed-type expansion tank. It would allow air to leave the system, causing waterlogging of the expansion tank.
- 11 Fill valve
- 12 Diaphragm-type or bladder-type expansion tank, if used (For closed-type expansion tank, pipe from top of air separator to tank fitting as in Figure 5, page 15.)

3e Water piping — refrigeration systems

Figure 13 Piping refrigeration systems

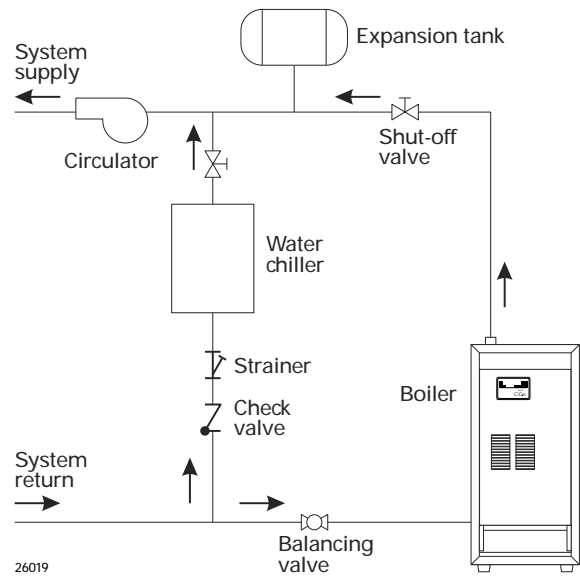

26019

Prevent chilled water from entering boiler

Install boiler so that chilled medium is piped in parallel with the heating boiler. Use appropriate valves to prevent chilled medium from entering boiler. See Figure 13 for typical installation of balancing valve and check valve.

If boiler is connected to heating coils located in air handling units where they can be exposed to refrigerated air, use flow control valves or other automatic means to prevent gravity circulation during cooling cycle.



4 Venting and combustion air

Install vent piping and air piping (if used) per appropriate **Venting Supplement** included in boiler envelope assembly.

Refer to **Venting Supplements** and to manual Section 1 regarding requirements for:

- vent system
- combustion air openings
- combustion air quality

⚠ DANGER

CGs Boiler must be vented and supplied with combustion and ventilation air as described in Weil-McLain CGs **Venting Supplements** packed in envelope assembly with boiler. Failure to do so will cause severe personal injury or death.

⚠ DANGER

Use **direct vent** (sealed combustion) if **combustion air quality cannot be assured to be free of contaminants**. Refer to page 9 for a list of potential contaminants and locations likely to contain them. Operating the boiler with contaminated air will damage the boiler sections and vent, resulting in possible boiler failure or leakage of flue products, causing severe personal injury, death or substantial property damage.



5 Gas piping

Connecting gas supply piping to boiler

1. Remove jacket front panel and refer to **Figure 14** to pipe gas to boiler.
 - a. **Install drip leg** at inlet of gas connection to boiler. Where local utility requires drip leg to be extended to the floor, use appropriate length of pipe between cap and tee.
 - b. **Install ground joint union** for servicing, when required.
 - c. **Install manual shutoff valve** in gas supply piping outside boiler jacket when required by local codes or utility requirements.
 - d. **In Canada** — When using manual main shutoff valve, it **must be identified** by the installer.
2. **Support piping** with hangers, not by boiler or its accessories.
3. **Purge all air** from gas supply piping.
4. Before placing boiler in operation, **check boiler and its gas connection for leaks.**
 - a. **Close manual main shutoff valve** during any pressure testing at less than 13" w.c.
 - b. **Disconnect boiler and gas valve from gas supply piping** during any pressure testing greater than 13" w.c.



Do not check for gas leaks with an open flame — use bubble test. Failure to use bubble test or check for gas leaks can cause severe personal injury, death or substantial property damage.

5. **Use pipe dope compatible with propane gases.** Apply sparingly only to male threads of pipe joints so that pipe dope does not block gas flow.



Failure to apply pipe dope as detailed above can result in severe personal injury, death or substantial property damage.

Table 4 Pipe capacity for 0.60 specific gravity natural gas

Gas pipe length (feet)	Capacity of pipe for pipe size of: (Capacity in cubic feet gas per hour)				
	½"	¾"	1"	1¼"	1½"
10	132	278	520	1050	1600
20	92	190	350	730	1100
30	73	152	285	590	860
40	63	130	245	500	760
50	56	115	215	440	670
75	45	93	175	360	545
100	38	79	150	305	460
150	31	64	120	250	380

Natural Gas:

1. Refer to **Table 4** for pipe length and diameter. Base on rated boiler input (divide by 1,000 to obtain cubic feet per hour). **Table 4 is only for gas with specific gravity 0.60, with a pressure drop through the gas piping of 0.30" w.c.** For additional gas pipe sizing information, refer to ANSI Z223.1 (or B149.1 or B149.2 for Canadian installations).
2. Inlet pressure required at gas valve inlet:
 - Maximum: 13" w.c.
 - Minimum: 5" w.c.
 - Manifold gas pressure: 3.5" w.c.
3. Install 100% lockup gas pressure regulator in supply line **if inlet pressure exceeds 13" w.c.** Adjust for 13" w.c. maximum.

Propane Gas:

1. Contact gas supplier to size pipes, tanks and 100% lockup gas pressure regulator.
2. Adjust propane supply regulator provided by gas supplier for 13" w.c. maximum pressure.
3. Inlet pressure required at gas valve inlet:
 - Maximum: 13" w.c.
 - Minimum: 11" w.c.
 - Manifold gas pressure: 10" w.c.

Figure 14 Gas supply piping

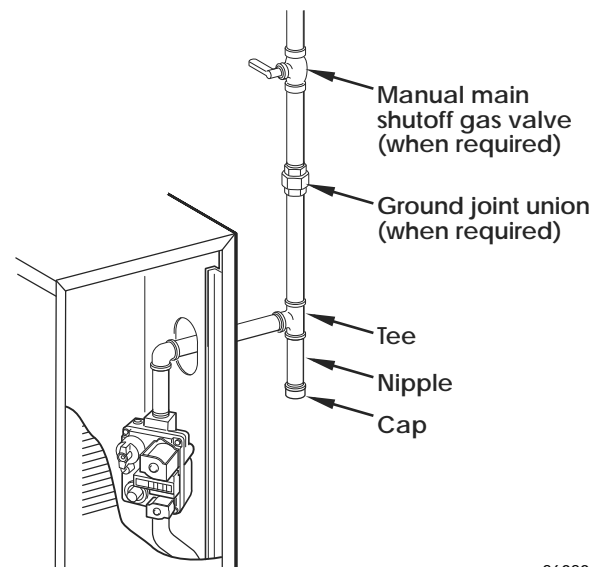



6 Field wiring

WARNING

For your safety, turn off electrical power supply at service entrance panel before making any electrical connections to avoid possible electric shock hazard. Failure to do so can cause severe personal injury or death.

NOTICE

Wiring must be N.E.C. Class 1.
 If original wiring as supplied with boiler must be replaced, use only type 105°C wire or equivalent.
 Boiler must be electrically grounded as required by National Electrical Code ANSI/NFPA 70 – latest edition.

Thermostat

1. Connect thermostat as shown on wiring diagram on boiler.
2. Install on inside wall away from influences of drafts, hot or cold water pipes, lighting fixtures, television, sunrays, or fireplaces.
3. If thermostat has a heat anticipator, set heat anticipator in thermostat to match power requirements of equipment connected to it. If connected directly to boiler, set for 0.4 amps. For other devices, refer to manufacturer’s specifications. Wiring diagram on boiler gives setting for control module and gas valve. Also see instructions with thermostat.

Electrical installation must comply with:

1. National Electrical Code and any other national, state, provincial or local codes or regulations.
2. In Canada, CSA C22.1 Canadian Electrical Code Part 1, and any local codes.

Junction Box (furnished)

1. Connect 120 VAC power wiring as shown in Figure 15.
2. Fused disconnect or service switch (15 amp. recommended) may be mounted on this box. For those installations with local codes which prohibit installation of fused disconnect or service switch on boiler, install a 2 x 4 cover plate on the boiler junction box and mount the service switch remotely as required by the code.

Wiring connections

Boiler is shipped with controls completely wired.

NOTICE The CGs control module is polarity-sensitive. The hot and neutral wires must be connected to the correct leads. A flashing **POWER** light usually indicates reversed polarity of 120 VAC lead wires.

Figure 15
 Field wiring connections — service switch and thermostat (or end switch) provided by installer

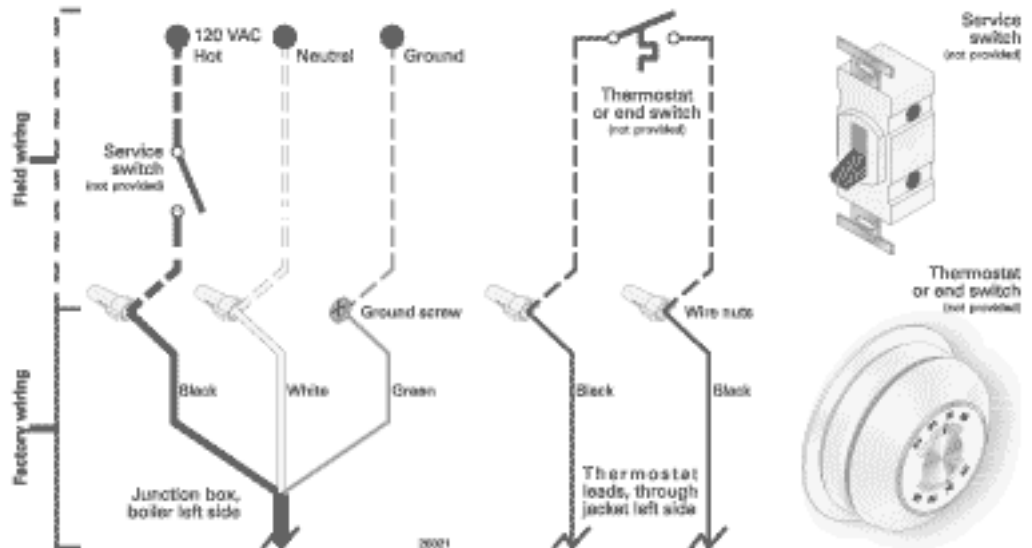



7a Start-up — preparation

Determine if water treatment is needed

▲ DANGER

Do not use **petroleum-based cleaning or sealing compounds** in boiler system. Severe damage to boiler will occur, resulting in substantial property damage.

▲ WARNING

Eliminate all system leaks. Continual fresh makeup water will reduce boiler life. Minerals can build up in sections, reducing heat transfer, overheating cast iron, and causing section failure.

Verify water chemistry

Consult local water treatment companies for unusually hard water areas (above 7 grains hardness) or low pH water conditions (below 7.0). Boiler water pH of 7.0 to 8.5 is recommended.

Freeze protection (when used)

Use antifreeze made especially for hydronic systems. Inhibited propylene glycol is recommended.

▲ WARNING

Do not use **ethylene glycol, automotive or undiluted antifreeze**. Severe personal injury or death can result.

1. Determine **antifreeze quantity** according to system water content. Boiler water content is listed on page 63. Remember to include expansion tank water content.
2. Follow antifreeze manufacturer's instructions.
3. A 50% solution of propylene glycol/water provides maximum protection to about -30°F.
4. Local codes may require **back flow preventer** or actual disconnect from city water supply.
5. When using antifreeze in a system with automatic fill, install a water meter to monitor water makeup. Glycol will leak before the water begins to leak, causing glycol level to drop. Added water will dilute the antifreeze, reducing the freeze protection level.

Check for gas leaks

▲ WARNING

Before starting the boiler, and during initial operation, smell near the floor and around the boiler for gas odorant or any unusual odor. Do not proceed with start-up if there is any indication of a gas leak. Repair any leak at once.

▲ WARNING

Propane boilers only — Your propane supplier mixes an odorant with the propane to make its presence detectable. In some instances, the odorant can fade and the gas may no longer have an odor.

- Propane gas can accumulate at floor level. Smell near the floor for the gas odorant or any unusual odor. If you suspect a leak, do not attempt to light the pilot.
- Use caution when attempting to light the propane pilot. This should be done by a qualified service technician, particularly if pilot outages are common.
- Periodically check the odorant level of your gas.
- Inspect boiler and system at least yearly to make sure all gas piping is leak-tight.
- Consult your propane supplier regarding installation of a gas leak detector. There are some products on the market intended for this purpose. Your supplier may be able to suggest an appropriate device.

Fill the system with water

1. Close manual and automatic **air vents** and boiler drain cock.
2. **Fill to correct system pressure.** Correct pressure will vary with each application. Typical cold water fill pressure for a residential system is 12 psi.
3. **Purge air** from system:
 - a. Connect a hose to the purge valve (see **drain valves**, item 6, in suggested piping diagrams on pages 17 through 21, **Figure 6** through **Figure 11**). Route hose to an area where water can drain and be seen.
 - b. Close the boiler or system isolation valve between the purge valve and fill connection to the system.
 - c. Close zone isolation valves.
 - d. Open quick-fill valve on cold water makeup line.
 - e. Open purge valve.
 - f. One zone at a time, open the isolation valves. Allow water to run through the zone, pushing out the air. Run until no noticeable air flow is present. Close the zone isolation valves and proceed with the next zone. Follow this procedure until all zones are purged.
 - g. Close the quick-fill water valve and purge valve and remove the hose. Open all isolation valves. Watch that system pressure rises to correct cold-fill pressure.
 - h. After the system has operated for a while, eliminate any residual air by using the manual air vents located throughout the system.
 - i. If purge valves are not installed in system, open manual air vents in system one at a time, beginning with lowest floor. Close vent when water squirts out. Repeat with remaining vents.
4. Open **automatic air vent** (diaphragm-type or bladder-type expansion tank systems only) one turn.
5. Open other vents:
 - a. Starting on the lowest floor, open air vents one at a time until water squirts out.
 - b. Repeat with remaining vents.
6. Refill to correct pressure.



7a Start-up — preparation (continued)

Inspect system water piping

After filling the boiler and system with water, inspect all piping throughout the system for leaks. If found, repair immediately. Repeat this inspection after the boiler has been started and the system has heated up.

▲ WARNING

Leaks must be repaired at once. Failure to do so can damage the boiler, resulting in substantial property damage.

▲ DANGER

Do not use petroleum-based cleaning or sealing compounds in boiler system. Severe damage to boiler will occur, resulting in substantial property damage.

Inspect base insulation

Check to make sure insulation is secure against all four sides of the base. If insulation is damaged or displaced, do not operate boiler. Replace or reposition insulation.

▲ WARNING

Failure to replace damaged insulation or reposition insulation can result in a fire hazard, causing severe personal injury, death or substantial property damage.

▲ WARNING

The boiler contains ceramic fiber and fiberglass materials. Use care when handling these materials per instructions on page 64 of this manual. Failure to comply could result in severe personal injury.

7b Start-up — operate boiler

Final check before starting boiler

- Read manual Section 9 including the Operating instructions (Section 9c).
- Verify the boiler and system are full of water.
- Verify the Start-up preparation procedures of Section 7a have been completed.

▲ WARNING

Eliminate all system leaks. Continual fresh makeup water will reduce boiler life. Minerals can build up in sections, reducing heat transfer, overheating cast iron, and causing section failure.

1. Check system piping for leaks. If found, shut down boiler and repair immediately.
2. Vent air from system using manual vents. Air in the system will interfere with circulation and cause heat distribution problems and noise.
3. Inspect vent system thoroughly for signs of deterioration from corrosion, physical damage or sagging. In addition — Check for gas-tight seal at every connection and seam.

Start the boiler

- Follow the Operating instructions from Section 9c to start the boiler.
- See Section 7c if boiler fails to start.

▲ WARNING

Venting system must be sealed gas-tight to prevent flue gas spillage and carbon monoxide emissions which will result in severe personal injury or death.

Check system and boiler

▲ DANGER

Do not use petroleum-based cleaning or sealing compounds in boiler system. Severe damage to boiler will occur, resulting in substantial property damage.

4. Check around the boiler for gas odor following the procedure of Section 7a of this manual.
5. Verify operation per Section 7b. Perform check-out procedure in Section 8, and fill in the Installation and service certificate on the same page.

7b Start-up — operate boiler (continued)

WARNING

If you discover evidence of any gas leak, shut down the boiler at once. Find the leak source with bubble test and repair immediately. Do not start boiler again until corrected. Failure to comply could result in severe personal injury, death or substantial property damage.

Check burner flames

View pilot and main flames through the inspection port in the Air inlet box front cover.

Pilot burner flame (Figure 16)

PROPER pilot flame characteristics

1. Blue flame.
2. Inner cone engulfing pilot flame sensor.
3. Pilot flame sensor glowing cherry red.

IMPROPER pilot flame characteristics:

1. Overfired — Large flame lifting or blowing past pilot flame sensor.
2. Underfired — Small flame. Inner cone not engulfing pilot flame sensor.
3. Lack of primary air — Yellow flame tip.
4. Incorrectly heated pilot flame sensor.

Main burner flame (Figure 17)

PROPER main burner flame characteristics

1. Yellow-orange streaks may appear (caused by dust).

IMPROPER main burner flame characteristics

1. Overfired — Large flames.
2. Underfired — Small flames.
3. Lack of primary air — Yellow tipping on flames (sooting will occur).

Figure 16 Typical pilot burner flame

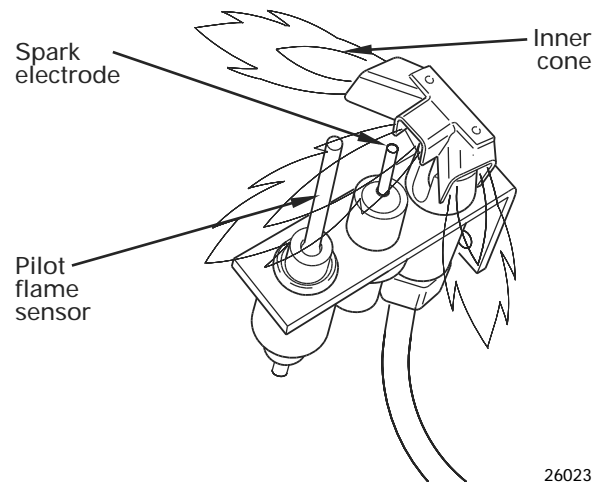
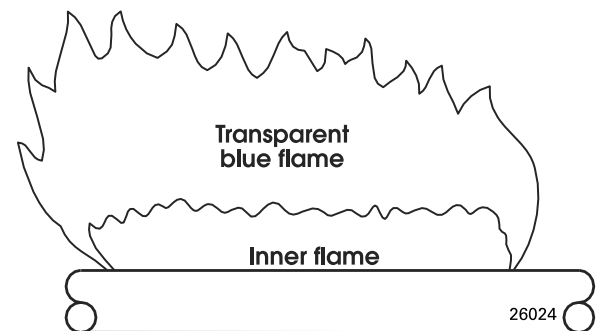

Figure 17 Typical main burner flame



7c Start-up — if boiler doesn't start . . .

Check for:

1. Loose connections, blown fuse or service switch off?
2. High limit switch set below boiler water temperature?
3. Thermostat set below room temperature?
4. Gas not turned on at meter or boiler?
5. Incoming gas pressure less than:
5" w.c. for natural gas?
11" w.c. for propane gas?
6. If none of the above corrects the problem, refer to **Troubleshooting**, Section 11 of this manual.



8 Check-out procedure — checklist

- Boiler and heat distribution units filled with water?
- Automatic air vent, if used, open one full turn?
- Air purged from system?
- Air purged from gas piping? Piping checked for leaks?
- Correctly sized manifold orifices installed? Refer to manual Section 2a to check size and fuel type.



Correctly sized manifold orifices must be used. Failure to do so will cause severe personal injury, death or substantial property damage.

- Followed operating instructions on boiler or in manual Section 9 for proper start-up?
- Proper burner flame observed? Refer to **Check burner flame**, manual Section 7b.
- Test limit control — While burners are operating, move indicator on limit control below actual boiler water temperature. Burners should go off while circulator continues to operate. Raise setting on limit control above boiler water temperature and burners should reignite.
- Test additional field-installed controls — If boiler has a low water cutoff, additional high limit or other controls, test for operation as outlined by manufacturer. Burners should be operating and should go off when controls are tested. When controls are restored, burners should reignite.
- Test ignition system safety device:
 - a. Connect manometer to outlet side of gas valve.
 - b. Start boiler, allowing for normal start-up cycle to occur and main burners to ignite.
 - c. With main burners on, manually shut off gas supply at manual main shutoff gas valve. Burners should go off.
 - d. Open manual main shutoff gas valve. Manometer should confirm there is no gas flow.
 - e. Pilot will relight, flame sensing element will sense pilot flame and main burners will reignite.

- Set limit control(s) to system temperature requirements. Adjust balancing valves and controls to provide design temperature to system.
- For multiple zones, adjust flow so it is about the same in each zone.
- Verify thermostat heat anticipator (if available) set properly? Refer to **Field wiring**, manual Section 6, **Thermostat(s)**.
- Cycle boiler with thermostat — Raise to highest setting and verify boiler goes through normal start-up cycle. Lower to lowest setting and verify boiler goes off.
- Measure natural gas input:
 - a. Operate boiler 10 minutes.
 - b. Turn off other appliances.
 - c. At natural gas meter, measure time (in seconds) required to use one cubic foot of gas.
 - d. Calculate gas input:

$$\frac{3600 \times 1000}{\text{number of seconds from step c}} = \text{Btuh}$$
 - e. Btuh calculated should approximate input rating on boiler rating label.
- Check manifold gas pressure by connecting manometer to downstream test tapping on main gas valve. Manifold pressure for natural gas should be 3.5" w.c. and for propane gas should be 10" w.c.
- Observe several operating cycles for proper operation.
- Set room thermostat to desired room temperature.
- Fill in Installation and service certificate below?
- Review all instructions shipped with this boiler with owner or maintenance person. Return instructions to envelope and give to owner or place in pocket inside front panel in boiler.

Installation and service certificate

Boiler model _____ Series _____ CP number _____ Date installed _____

Measured Btuh input _____

- Installation instructions have been followed.
- Check out sequence has been performed.
- Above information is certified to be correct.
- Information received and left with owner/maintenance person

Installer _____ (company) _____ (address) _____ (phone)

Installer's signature: _____



9a Operation — sequence

1. **Read appropriate Operating instructions** in Section 9c. This information is also located on a label on the inside of the boiler jacket door panel.
2. **Raise room thermostat** to call for heat.
3. **Circulator energizes.** If limit circuit is closed, the inducer starts. After pressure switch proves proper airflow, control module initiates a 30-second pre-purge.
4. **Control module sparks the pilot** and opens pilot valve in main gas valve.
 - a. If **pilot does not light** within 15 seconds, pilot valve is closed and spark generator is turned off. Control module initiates a 15-second postpurge, then starts a new cycle.
 - b. If **pilot does light** and control module senses flame current, spark generator is turned off and main valve opens.
5. **During main burner operation:**
 - a. Control module monitors pilot flame current. **If signal is lost**, main valve closes, spark generator activates and sequence returns to step 4.
 - b. **If power is interrupted**, control system **shuts off pilot** and main gas valves and restarts at step 1 when power is restored.
6. In the event the **limit control shuts down the boiler** — The control module closes the pilot and main gas valves, but keeps the inducer operating for 15-second postpurge.
 - The circulator continues to operate.
7. **Lower room thermostat setting** to stop call for heat. Thermostat is satisfied — Pilot and main gas valves are closed — Inducer operates for 15-second postpurge — Circulator is shut off.
8. Boiler is now in the **off cycle**.
9. **Repeat steps 1 through 6** several times to verify operation.
10. **Return** the thermostat to normal setting.
11. Set thermostat heat anticipator setting to 0.4 amps, adjusted for gas valve and control current.

Figure 18 Control module sequence of operation — status light indications

Steps <small>(Following step 8, cycle goes back to step 1.)</small>	Call for heat?	POWER	TSTAT CIRC	LIMIT	PRESS SWITCH	FLAME	Timing
1. Standby · Waiting for call for heat	NO						—
2. Call for heat · Circulator on	YES						—
3. Limit circuit · Limit controls closed · Block switch contacts closed	YES						—
4. Inducer · Inducer turns on	YES						—
5. Pressure circuit · Pressure switch contacts closed · Prepurge for 30 seconds	YES						35 sec
6. Pilot flame proven * · Gas valve open · Pilot remains on · Boiler producing heat	YES						15 sec
7. Limit cycle · Limit circuit open · Gas valve closed	YES						—
8. Flame outage * · Flame out · Boiler recycles	YES						—
9. Thermostat satisfied · Circulator off · Blower postpurge	NO						15 sec
10. Circulator exercise routine · Circulator turns on for 30 seconds if boiler not operated for 30 days	NO						30 sec
			or		= "ON"		= "OFF"
* If pilot flame is not proven in 15 seconds, control module will flash the FLAME light, but will continue indefinitely with attempts to light the pilot burner. The control module will not lockout on a failure to establish flame. It will lockout if line voltage polarity is reversed, stray voltage is sensed on thermostat line, pressure switch sticks closed or fails to make within 5 minutes or if flame is sensed when it shouldn't be there. The boiler will reset after these lockouts if any of the following occurs:							
		· 1 hour waiting period	· Opening and closing of thermostat circuit			· Removal of 120 VAC power for at least 45 seconds.	26030



9b Operation — wiring diagrams

Figure 19 Schematic wiring diagram

NOTICE

- The control module is polarity-sensitive to the incoming 120 VAC power. If polarity is reversed, control will flash the **POWER** light when powered and will not cycle boiler.
- All contacts shown without power applied.
- Connector and status light locations/orientations may vary.

White
Red

Plug-in connectors

* Items not provided

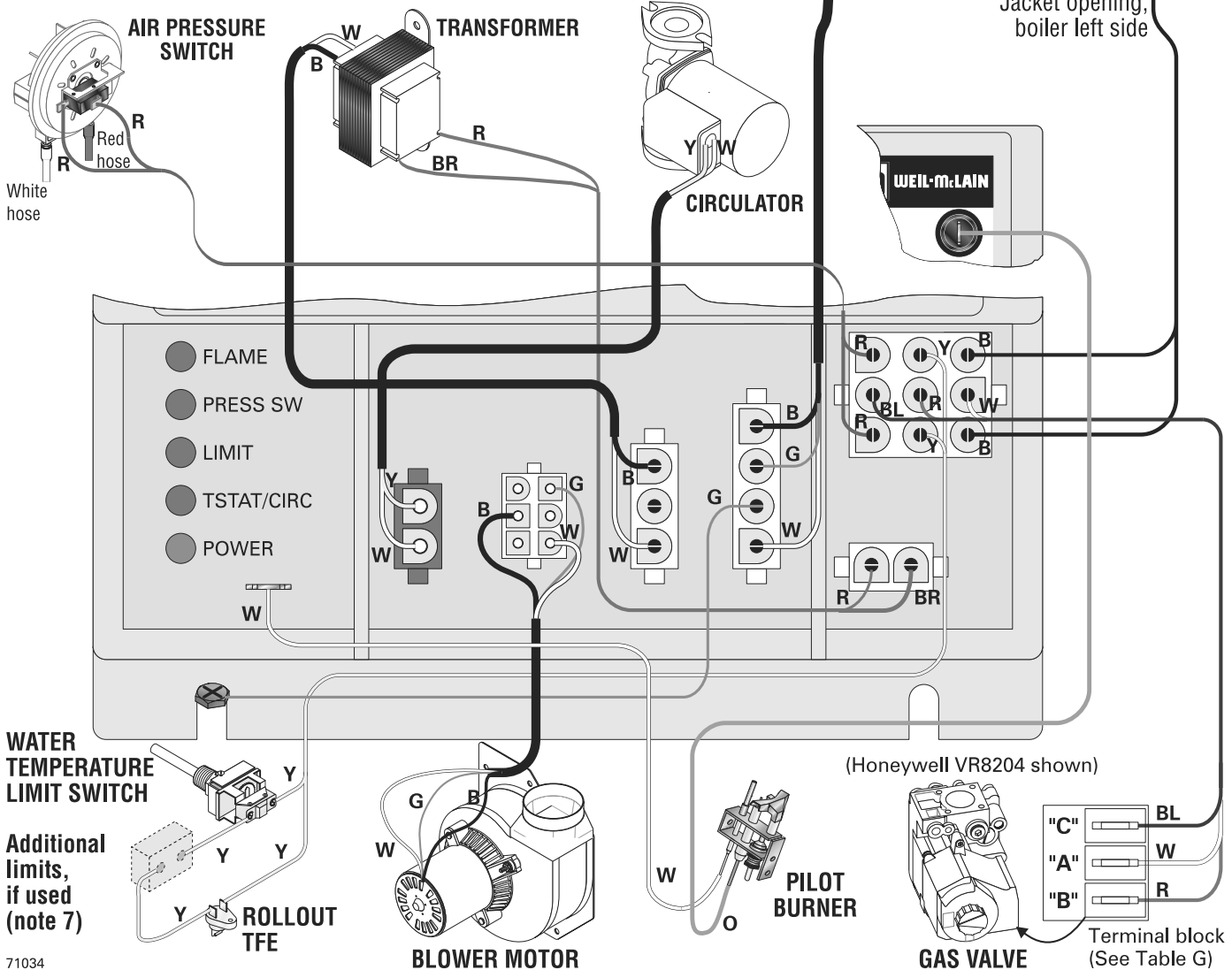
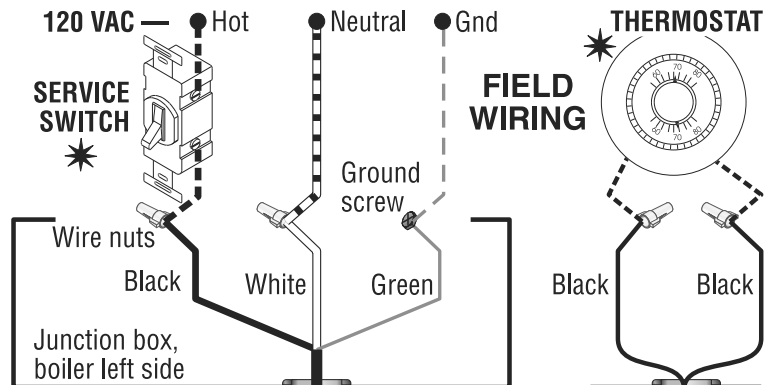

71034



Figure 20 Ladder wiring diagram

WARNING Electrical shock hazard — can cause severe injury or death. Disconnect power before installing or servicing.

NOTICE All contacts are shown without power applied.

Legend for ladder wiring diagram

- 120 VAC field wiring
- Low voltage field wiring
- 120 VAC factory wiring
- Low voltage factory wiring
- High voltage spark ignition wiring
- Ground connectors

Table G: Gas valve terminals and anticipator settings

Gas valve	"A"	"B"	"C"	Anticipator amps
Honeywell VR8204	MV/PV	MV	PV	0.6
Honeywell VR8304	MV/PV	MV	PV	0.8
White-Rodgers 36E	2	1	3	0.64
White-Rodgers 36C	2-4 *	1	3	0.7

* Terminals 2-4 are factory-jumpered on the White-Rodgers 36C gas valve.

- All wiring must be installed in accordance with:
 - U.S.A. — N.E.C. And any other national, state, or local code requirements.
 - Canada — C.S.A. C22.1 C.E.C. Part 1 and any other national, provincial, or local code requirements.
- Pilot lead wires are not field replaceable. Replace pilot assembly if necessary.
- If any of the original wire as supplied with the appliance must be replaced, use minimum 105 °C wire or equivalent. Exception — wires to a rollout TFE must be 200 °C or equivalent.
- Thermostat anticipator setting (single zone) — see Table G for anticipator setting, depending on which gas valve is installed in boiler.
- For multiple zoning, use either zone valves or circulators. Refer to the component manufacturer's instructions and this manual for application and wiring suggestions.
- Refer to control component instructions packed with the boiler for application information.
- Wire any additional limit controls (low water cut-off, additional high limit, etc.) in series with boiler limit control as shown.

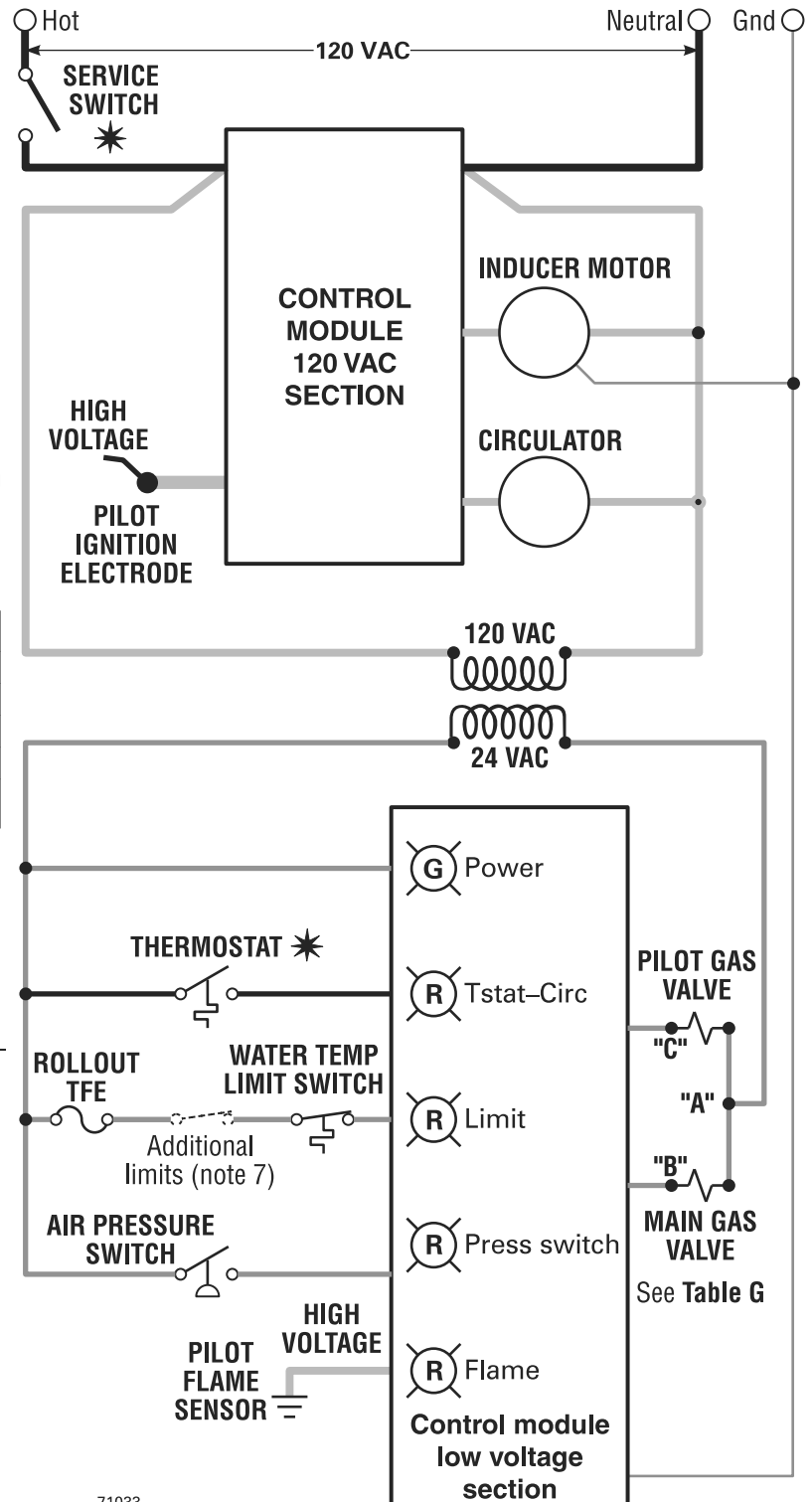

71033



9c Operating instructions CGs-3 to CGs-6

- Spark pilot
- Natural or propane gas
- Gas valve: Honeywell VR8204/VR8304

FOR YOUR SAFETY READ BEFORE OPERATING

WARNING If you do not follow these instructions exactly, a fire or explosion may result causing property damage, personal injury or loss of life.

- This appliance is equipped with an ignition device which automatically lights the pilot. Do not try to light the pilot by hand.
- BEFORE OPERATING**, smell all around the appliance area for gas. Be sure to smell next to the floor because some gas is heavier than air and will settle on the floor. See below.
- Use only your hand to turn the gas control knob. Never use tools. If the knob will not turn by hand, don't try to repair it, call a qualified service technician. Force or attempted repair may result in a fire or explosion.
- Do not use this appliance if any part has been under water. Immediately call a qualified service technician to inspect the appliance and to replace any part of the control system and any gas control, which has been under water.

WHAT TO DO IF YOU SMELL GAS

- Do not try to light any appliance.
- Do not touch any electric switch; do not use any phone in your building.
- Immediately call your gas supplier from a neighbor's phone. Follow the gas supplier's instructions.
- If you cannot reach your gas supplier, call the fire department.

OPERATING INSTRUCTIONS

- STOP!** Read the safety information above on this label.
- Set the thermostat to lowest setting.
- Turn off all electrical power to the appliance.
- Remove front panel.
- This appliance is equipped with an ignition device which automatically lights the pilot. Do not try to light the pilot by hand.
- Turn gas control knob clockwise ↻ to "OFF."
- Wait five (5) minutes to clear out any gas. Then smell for gas, including near the floor. If you smell gas, **STOP!** Follow "B" in the safety information above. If you don't smell gas, go to the next step.
- Turn gas control knob counterclockwise ↺ to "ON."
- Turn on all electric power to the appliance.
- Set thermostat to desired setting.
- If the appliance will not operate, follow the instructions "To Turn Off Gas To The Appliance" and call your service technician or gas supplier.
- Replace front panel.

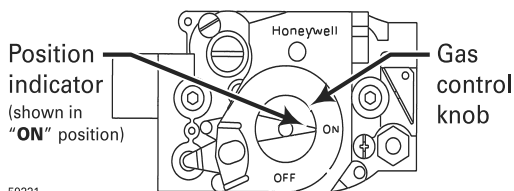

TO TURN OFF GAS TO THE APPLIANCE

- Set the thermostat to lowest setting.
- Turn off all electric power to the appliance if service is to be performed.
- Remove front panel.
- Turn gas control knob clockwise ↻ to "OFF." Do not force.
- Replace front panel.

550-223-041(0906)



9c Operating instructions CGs-3 to CGs-6

- Spark pilot
- Natural or propane gas
- Gas valve: White-Rodgers 36E

FOR YOUR SAFETY READ BEFORE OPERATING

WARNING If you do not follow these instructions exactly, a fire or explosion may result causing property damage, personal injury or loss of life.

- This appliance is equipped with an ignition device which automatically lights the pilot. Do not try to light the pilot by hand.
- BEFORE OPERATING**, smell all around the appliance area for gas. Be sure to smell next to the floor because some gas is heavier than air and will settle on the floor. See below.
- Use only your hand to turn the gas control knob. Never use tools. If the knob will not turn by hand, don't try to repair it, call a qualified service technician. Force or attempted repair may result in a fire or explosion.
- Do not use this appliance if any part has been under water. Immediately call a qualified service technician to inspect the appliance and to replace any part of the control system and any gas control, which has been under water.

WHAT TO DO IF YOU SMELL GAS

- Do not try to light any appliance.
- Do not touch any electric switch; do not use any phone in your building.
- Immediately call your gas supplier from a neighbor's phone. Follow the gas supplier's instructions.
- If you cannot reach your gas supplier, call the fire department.

OPERATING INSTRUCTIONS

- STOP!** Read the safety information above on this label.
- Set the thermostat to lowest setting.
- Turn off all electrical power to the appliance.
- Remove front panel.
- This appliance is equipped with an ignition device which automatically lights the pilot. Do not try to light the pilot by hand.
- Turn gas control knob clockwise ↻ to "OFF."
- Wait five (5) minutes to clear out any gas. Then smell for gas, including near the floor. If you smell gas, **STOP!** Follow "B" in the safety information above. If you don't smell gas, go to the next step.
- Turn gas control knob counterclockwise ↺ to "ON."
- Turn on all electric power to the appliance.
- Set thermostat to desired setting.
- If the appliance will not operate, follow the instructions "To Turn Off Gas To The Appliance" and call your service technician or gas supplier.
- Replace front panel.

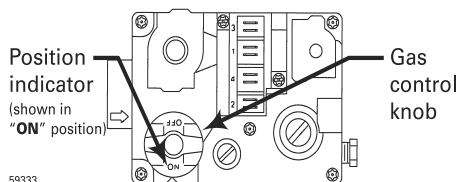

TO TURN OFF GAS TO THE APPLIANCE

- Set the thermostat to lowest setting.
- Turn off all electric power to the appliance if service is to be performed.
- Remove front panel.
- Turn gas control knob clockwise ↻ to "OFF." Do not force.
- Replace front panel.

550-223-042(0906)



9c Operating instructions CGs-3 to CGi-6

- Spark pilot
- Natural or propane gas
- Gas valve: White-Rodgers 36C

FOR YOUR SAFETY READ BEFORE OPERATING

⚠ WARNING If you do not follow these instructions exactly, a fire or explosion may result causing property damage, personal injury or loss of life.

- This appliance is equipped with an ignition device which automatically lights the pilot. Do not try to light the pilot by hand.
- BEFORE OPERATING**, smell all around the appliance area for gas. Be sure to smell next to the floor because some gas is heavier than air and will settle on the floor. See below.
- Use only your hand to depress or turn the gas control knob. Never use tools. If the knob will not depress or turn by hand, don't try to repair it, call a qualified service technician. Force or attempted repair may result in a fire or explosion.
- Do not use this appliance if any part has been under water. Immediately call a qualified service technician to inspect the appliance and to replace any part of the control system and any gas control, which has been under water.

WHAT TO DO IF YOU SMELL GAS

- Do not try to light any appliance.
- Do not touch any electric switch; do not use any phone in your building.
- Immediately call your gas supplier from a neighbor's phone. Follow the gas supplier's instructions.
- If you cannot reach your gas supplier, call the fire department.

OPERATING INSTRUCTIONS

- STOP!** Read the safety information above on this label.
- Set the thermostat to lowest setting.
- Turn off all electrical power to the appliance.
- Remove front panel.
- This appliance is equipped with an ignition device which automatically lights the pilot. Do not try to light the pilot by hand.
- Depress gas control knob slightly and turn clockwise ↻ to "OFF." Note: Knob cannot be turned to "OFF" unless knob is depressed slightly. Do not force.
- Wait five (5) minutes to clear out any gas. Then smell for gas, including near the floor. If you smell gas, **STOP!** Follow "B" in the safety information above. If you don't smell gas, go to the next step.
- Turn gas control knob counterclockwise ↻ to "ON."
- Turn on all electric power to the appliance.
- Set thermostat to desired setting.
- If the appliance will not operate, follow the instructions "To Turn Off Gas To The Appliance" and call your service technician or gas supplier.
- Replace front panel.

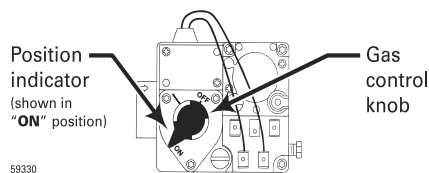

TO TURN OFF GAS TO THE APPLIANCE

- Set the thermostat to lowest setting.
- Turn off all electric power to the appliance if service is to be performed.
- Remove front panel.
- Depress gas control knob slightly and turn clockwise ↻ to "OFF." Do not force.
- Replace front panel.

550-223-043(0906)



10a Service and maintenance — schedule

VERIFY PROPER OPERATION AFTER SERVICING

Table 5 Service and maintenance schedules

Service technician (see following pages for instructions)		Owner maintenance (see CGs User’s Information Manual for instructions)	
ANNUAL START-UP	Inspect:		Daily
	<ul style="list-style-type: none"> • Reported problems • Boiler area • Air openings • Flue gas vent system (and air piping) • Pilot and main burner flames • Water piping • Boiler heating surfaces • Burners, base and inlet air box • Condensate drain system 	<ul style="list-style-type: none"> • Check boiler area • Check air openings • Check boiler pressure/temperature gauge 	
	Service:	Monthly	<ul style="list-style-type: none"> • Check boiler interior piping • Check venting system • Check air vents • Check boiler relief valve • Check condensate drain system • Check automatic air vents (if used)
	Start-up:	Periodically	<ul style="list-style-type: none"> • Test low water cutoff (if used) • Clean vent termination/air intake screens
	Check/test:	Every 6 months	<ul style="list-style-type: none"> • Oil inducer motor • Operate relief valve
Review:	End of season	<ul style="list-style-type: none"> • Shut down procedure 	
<ul style="list-style-type: none"> • Perform start-up per manual 	Check/test:		
<ul style="list-style-type: none"> • Gas piping • Cold fill and operating pressures • Air vents and air elimination • Limit controls and cutoffs • Expansion tank • Boiler relief valve 	Review:		
<ul style="list-style-type: none"> • Review with owner 			



Follow the **Service and maintenance** procedures given throughout this manual and in component literature shipped with the boiler. Failure to perform the service and maintenance could result in damage to the boiler or system. Failure to follow the directions in this manual and component literature could result in severe personal injury, death or substantial property damage.



10b Service & maintenance — annual start-up

▲ WARNING

The boiler should be **inspected and started annually**, at the beginning of the heating season, **only by a qualified service technician**. In addition, the maintenance and care of the boiler designated in **Table 5**, page 37, and explained on the following pages must be performed to assure maximum boiler efficiency and reliability. Failure to service and maintain the boiler and system could result in equipment failure.

▲ WARNING

Eliminate all system or boiler leaks. Continual fresh makeup water will reduce boiler life. Minerals can build up in sections, reducing heat transfer, overheating cast iron, and causing section failure. Leaking water may also cause severe property damage.

▲ DANGER

Do not use **petroleum-based cleaning or sealing compounds** in boiler system. Severe damage to boiler will occur, resulting in substantial property damage.

▲ WARNING

Electrical shock hazard — **Turn off power to the boiler before any service operation** on the boiler except as noted otherwise in this instruction manual. Failure to turn off electrical power could result in electrical shock, causing severe personal injury or death.

☐ Inspect . . .

Reported problems

Inspect any problems reported by owner and correct before proceeding.

Boiler area

1. Verify that boiler area is free of any **combustible materials**, gasoline and other flammable vapors and liquids.
2. Verify that boiler area (and air intake) is free of any of the **contaminants** listed in **Table 1** on page 9 of this manual. If any of these are present in the boiler intake air vicinity, they must be removed. If they cannot be removed, isolate the boiler and provide outside combustion air. See national, provincial or local codes for further information.

Air openings

1. Verify that combustion and ventilation air openings to the boiler room and/or building are open and **unobstructed**.
2. Verify that boiler vent discharge is **clean and free of obstructions**.

Flue gas vent system

1. **Visually inspect entire flue gas venting system** for blockage, deterioration or leakage. Repair any joints that show signs of leakage in accordance with vent manufacturer's instructions. When air is ducted to boiler, verify that air inlet hose is connected and properly sealed.

▲ WARNING

Failure to inspect for the above conditions and have them repaired can result in severe personal injury or death.

Pilot and main burner flames

1. Visually inspect pilot burner and main burner flames as directed under **Start-up**, Section 7 of this manual.

Water piping

1. Check the boiler interior piping and all system piping for signs of leaks.
2. Repair any leaks before proceeding.

Boiler heating surfaces

1. Disconnect the vent pipe at the boiler inducer outlet connection after turning off power to the boiler.
2. Use a bright light to inspect the flue pipe interior and inducer interior.
3. Inspect the boiler vent outlet area and heating surfaces by looking through the opening.
4. If the vent pipe or inducer interior show evidence of soot, follow **Cleaning boiler heating surfaces** in this manual section to remove the flue collector and clean the boiler if necessary after close inspection of boiler heating surfaces. If there is evidence of rusty scale deposits, check the water piping and control system to make sure the boiler return water temperature is properly maintained (per this manual).
5. Reconnect vent to inducer outlet and replace all boiler components before returning to service.
6. Check inside and around boiler for evidence of any leaks from the boiler. If found, locate source of leaks and repair.



□ Inspect . . .

Burners, base and inlet air box

▲WARNING

The boiler contains ceramic fiber and fiberglass materials. Use care when handling these materials per instructions on page 68 of this manual. Failure to comply could result in severe personal injury.

▲WARNING

If insulation is damaged or displaced, do not operate the boiler. Replace or reposition insulation as necessary. Failure to replace damaged insulation can result in a fire hazard, causing severe personal injury, death or substantial property damage.

1. After turning off power to the boiler, remove the inlet air box top panel (Figure 27, item 13, page 56).
2. Inspect gasket (item 14). Replace if necessary.
3. Inspect burners and all other components in the inlet air box and boiler base.
4. If burners must be cleaned, first remove item 11, Figure 27, page 56. Access the burner assembly by first removing burner baffle, item 4. Then remove the screws securing the burner tray to the manifold. Slide the burner tray out. Follow **Burner cleaning instructions** below to clean burners thoroughly.
6. Inspect the base insulation. Pay attention to the **WARNING** on page 64 regarding working with insulation materials. Verify that the insulation is intact and secure against all four sides of the base.
7. Replace all components when service has been completed.

Burner cleaning instructions

▲WARNING

Airborne materials, such as fiberglass and dust, are present during construction and remodeling. These materials can be drawn in with the combustion air and obstruct burner ports, resulting in carbon monoxide production, a fire hazard, or building freeze damage. Read and follow the **WARNING** on page 9. Failure to inspect and clear gas burner ports could result in severe personal injury, death or substantial property damage.

1. Inspect each burner to insure that every port is completely open.
2. If any port is not completely clear, run a vacuum at the burner inlet while cleaning the burner ports with a wire brush. The vacuum will help to draw any airborne material out of the burner.
3. Follow instructions above to replace all components after cleaning.

Condensate drain system

1. Inspect condensate drain fittings and tubing. Verify that condensate can flow freely to drain.

□ Service . . .

Inducer motor

1. With boiler power **off**, place a few drops of S.A.E. 20 motor oil in each of the two oil cups.

▲WARNING

Use only **S.A.E. 20 motor oil** to lubricate the inducer motor. Do not use universal household oils. Motor could be damaged, resulting in possible severe property damage.

Oiled-bearing circulators

1. The circulator shipped with the CGs boiler is water-lubricated. No oiling is required.
2. Check other circulators in the system. Oil any circulators requiring oil, following circulator manufacturer's instructions. Over-oiling will damage the circulator.

□ Start-up . . .

1. Perform all start-up procedures in Section 7 of this manual.
2. Verify **cold fill pressure** is correct and that fill system is working properly.
3. Verify **antifreeze level** (if used) is at the right concentration and that inhibitor level is correct.
4. **Check gas piping**, per manual Sections 5 and 7, verifying no indications of leakage and all piping and connections are in good condition.
5. Read the **Operating instructions** (Section 9c of this manual or on boiler label) applying to the boiler.
6. Start the boiler following the **Operating instructions** (Section 9c of this manual or on boiler label) and manual Section 7.

10b Service & maint. — annual start-up continued

☐ Check/test . . .

Gas piping

1. Sniff near floor and around boiler area for any indication of a **gas leak**.
2. **Test gas piping using bubble test**, per Section 5 of this manual, if there is any indication of a leak.

Cold fill and operating pressures

1. While the system is cold, note the **pressure reading** on the boiler pressure/temperature gauge. Verify that cold fill pressure is correct.
2. **Watch the pressure** as the boiler and system heat up to ensure pressure rise is normal. Too high a rise would indicate a waterlogged or undersized expansion tank.

Air vents and air elimination

1. Inspect automatic air vents (if used). Also inspect air separators to ensure they are operational.
2. The cap must be unscrewed one turn to allow air to escape.
3. See **Figure 22**. If the air vent is leaking, remove cap **A** and briefly push valve **B** and then release to clean the valve seat.
4. Replace cap **A** by twisting all the way onto valve **B** and then unscrewing one turn.

Figure 22 Automatic air vent, typical

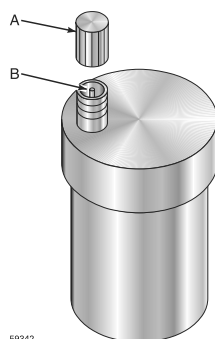

Limit controls and cutoffs

1. Inspect and test the boiler limit control. Verify operation by turning control set point below boiler temperature. Boiler should cycle off. Return dial to original setting.
2. Inspect and test additional limit controls or low water cutoffs installed on system.

Expansion tank

1. Expansion tanks provide space for water to move in and out as the heating system water expands due to temperature increase or contracts as the water cools. Tanks may be open, closed or diaphragm or bladder type. See Section 3 of this manual for suggested best location of expansion tanks and air eliminators.

Open-type — located above highest radiator or baseboard unit, usually in the attic or closet. Has a gauge glass and overflow pipe to a drain.

Closed-type — welded gas tight and located above boiler. Tank is partially filled with water, leaving an air cushion for expansion.

- Make sure this type of tank is fitted with a **tank fitting**, such as the B & G *Tank-Trol* or Taco *Taco-Trol*. This fitting reduces gravity circulation of air-saturated tank water back to the system and prevents the air from bubbling up through the water as it returns from the system.
- **Do not use automatic air vents in systems with closed-type tanks.** The air will escape from the system instead of returning to the tank. Eventually, the tank will waterlog and no longer control pressurization. The boiler relief valve will weep frequently.

Diaphragm- or bladder-type — welded gas tight with a rubber membrane to separate the tank pressurizing air and the water. May be located at any point in the system, but most often found near the boiler.

- Systems with this type of expansion tank require at least one **automatic air vent**, preferably located on top of an air eliminator, as shown in examples in manual Section 3.
2. If relief valve has tended to weep frequently, the expansion tank may be waterlogged or undersized.

Closed-type tank — tank is most likely waterlogged. Install a tank fitting if not already installed. Then check fill level per fitting manufacturer's instructions. If fill level is correct, check tank size against manufacturer's instructions. Replace with a larger tank if necessary.

Diaphragm- or bladder-type — first, check tank size to be sure it is large enough for the system. If size is too small, add additional tank(s) as necessary to provide sufficient expansion. If tank size is large enough, remove tank from system and check charge pressure (usually 12 psig for residential applications). If tank won't hold pressure, membrane has been damaged. Replace tank.

▲ WARNING

Safety relief valves should be **reinspected AT LEAST ONCE EVERY THREE YEARS**, by a licensed plumbing contractor or authorized inspection agency, to ensure that the product has not been affected by corrosive water conditions and to ensure that the valve and discharge line have not been altered or tampered with illegally. Certain naturally occurring conditions may corrode the valve or its components over time, rendering the valve inoperative. Such conditions are not detectable unless the valve and its components are physically removed and inspected. This inspection must only be conducted by a plumbing contractor or authorized inspection agency — not by the owner. Failure to reinspect the boiler relief valve as directed could result in unsafe pressure buildup, which can result in severe personal injury, death or substantial property damage.

▲ WARNING

Following installation, the **valve lever must be operated AT LEAST ONCE A YEAR** to ensure that waterways are clear. Certain naturally occurring mineral deposits may adhere to the valve, rendering it inoperative. When manually operating the lever, water will discharge and precautions must be taken to avoid contact with hot water and to avoid water damage. Before operating lever, check to see that a discharge line is connected to this valve directing the flow of hot water from the valve to a proper place of disposal otherwise severe personal injury may result. **If no water flows, valve is inoperative.** Shut down boiler until a new relief valve has been installed.

Boiler relief valve

1. Inspect the relief valve and lift the lever to verify flow as in the following warnings, excerpted from a relief valve manufacturer's warning label. Before operating any relief valve, ensure that it is piped with its discharge in a safe area to avoid severe scald potential. Read manual Section 3 before proceeding further.
2. After following the above warning directions, if the relief valve weeps or will not seat properly, replace the relief valve. Ensure that the reason for relief valve weeping is the valve and not over-pressurization of the system due to expansion tank waterlogging or undersizing.

Figure 23 Relief valve, typical

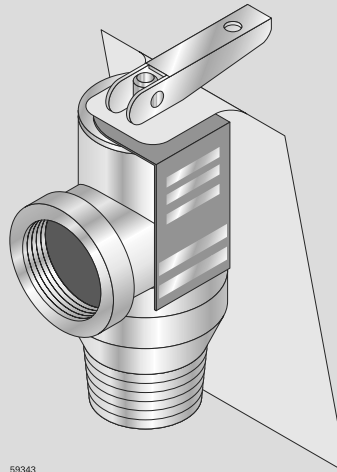



10b Service & maint. — annual start-up

☐ Review with owner

1. Review the **User's Information Manual** with the owner.
2. Emphasize the need to perform the maintenance schedule specified in the **User's Information Manual** (and in this manual as well).
3. Remind the owner of the need to call in a licensed contractor should the boiler or system exhibit any unusual behavior.
4. Remind the owner to follow the proper shutdown procedure and to schedule an annual start-up at the beginning of the next heating season.

☐ Cleaning boiler heating surfaces



The boiler contains ceramic fiber and fiberglass materials. Use care when handling these materials per instructions on **page 64** of this manual. Failure to comply could result in severe personal injury.

1. Shut down boiler:
 - Follow “**To Turn Off Gas to Appliance**” instructions on boiler and **Operating instructions**.
 - Do not drain boiler unless it will be exposed to freezing temperatures. If using antifreeze in system, do not drain.
2. Follow shutdown procedure.
3. Remove venting system connection to boiler.
4. Remove top jacket panel. Turn back insulation.
5. Remove collector box/transition assembly. Clean sealant from assembly and sections.
6. Remove radiation plates hanging between sections.
7. Remove burners from base. Brush and vacuum burners to remove all dust and lint. Verify that all burner ports are free of debris.
8. Place newspapers in base of boiler to collect soot.
9. Clean between sections with wire flue brush.
10. Remove newspaper and soot. Vacuum or brush base and surrounding area.
11. Reinstall radiation plates.
12. Replace collector box/transition assembly. Seal with sealant. Obtain gas-tight seal to prevent flue gas spillage and carbon monoxide emissions, resulting in severe personal injury or death.
13. Replace insulation and jacket top panel.
14. Start up boiler following Section 7 of this manual and the boiler **Operating instructions** (Section 9c of this manual). Excessive sooting indicates improper gas combustion. If found check for proper combustion and make any necessary adjustments.



11a Troubleshooting — procedure

⚠ WARNING

Label all wires prior to disconnection when servicing controls. Wiring errors can cause improper and dangerous operation.

⚠ WARNING

Never jumper (bypass) rollout thermal fuse element or any other device except for momentary testing as outlined in **Troubleshooting Charts**. Severe personal injury, death or substantial property damage can result.

Before troubleshooting:

1. Have the following items:
 - a. Voltmeter that can check 120 VAC and 24 VAC.
 - b. Microammeter with a minimum scale range of 0-25.
 - c. Continuity checker.
 - d. U-tube manometer.
2. Check for 120 VAC (minimum 102 VAC to maximum 132 VAC) to boiler.
3. Make sure thermostat is calling for heat and contacts (including appropriate zone controls) are closed. Check for 24 VAC between thermostat wire nuts and ground.

Check the following:

1. Wire connectors to control module are securely plugged in at module and originating control.
2. Air pressure switch hoses are properly and securely plugged in and are not damaged.
3. Gas pressures:
 - a. With boiler off — 13" w.c. maximum natural or propane gas pressure upstream of gas valve.
 - b. With boiler on:
 - 5" w.c. minimum natural gas pressure or 11" w.c. propane gas pressure upstream of gas valve.
 - 3 ½" w.c. minimum natural gas pressure or 10" w.c. propane gas pressure downstream of gas valve — Can be adjusted by regulator on gas valve.



11b Troubleshooting — air pressure switch

Air pressure switch

NOTICE Make sure boiler water temperature is 100 °F or cooler before starting procedure to obtain appropriate readings.

Check pressure switch setting

1. See Figure 24 and Table 6.
2. Remove both air pressure switch hoses from air pressure switch.
3. Install tees and tubing as shown in Figure 24 to inclined manometer.
4. Turn off gas valve and set thermostat to call for heat. Inducer will run but burners will not ignite.
5. Check for 24 VAC between both air pressure switch terminals and ground.
6. If manometer reading is above the setpoint of the switch (see Table 6), but there is not 24 VAC between both air pressure switch terminals and ground — replace air pressure switch.

Table 6 Pressure switch setpoint
(for elevations above 2,000 ft, contact your local Weil-McLain sales office for details.)

Boiler model number	Inches W.C.
CGs-3	1.79"
CGs-4	1.48"
CGs-5	1.22"
CGs-6	0.95"

Troubleshooting air pressure reading

1. If manometer reading is lower than the setpoint of the switch (see Table 6) — check for possible causes:
 - blockage in hoses
 - obstruction in inducer housing outlet
 - loose inducer wheel on motor shaft
 - inducer motor not in proper rpm
 - inducer back plate not sealed properly
 - blockage in block assembly
 - blockage in flue pipe or termination
 - incorrect pressure switch

Figure 24 Manometer connections

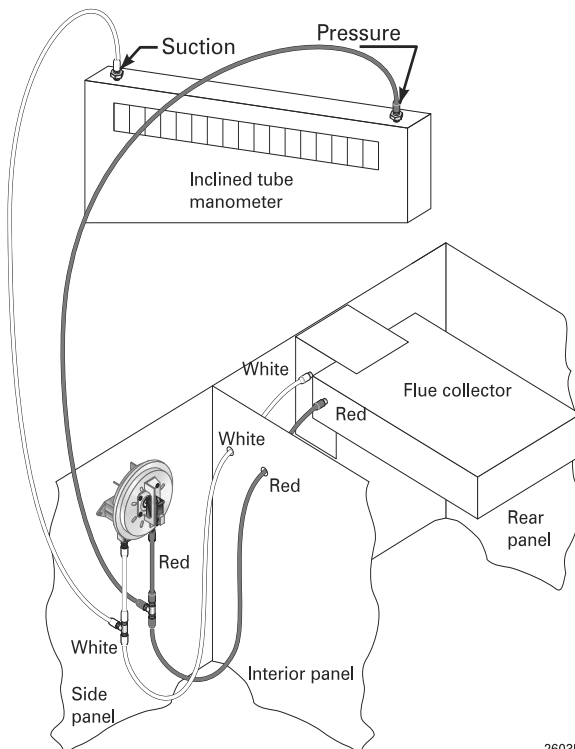

Return to normal operation

When pressure reading is correct and air pressure switch is operating properly — remove tees and reinstall hoses to air pressure switch.

NOTICE The boiler will not operate correctly unless pressure switch hoses are correctly located. The red hose connects from the right side (negative) hose barb to the flue collector. The white hose connects from the left side (positive) hose barb of the switch to the connector box (between flue collector and inducer) as shown in Figure 24.



11c Troubleshooting — control module

Control module



WARNING Solder or water splatter between plugs and circuit board can cause improper operation of control module. Place a shield over the boiler internal controls and components during installation. Failure to comply could result in severe personal injury, death or substantial property damage.



NOTICE Make sure ground wiring is installed per wiring diagram. Good grounding is extremely important for proper operation.

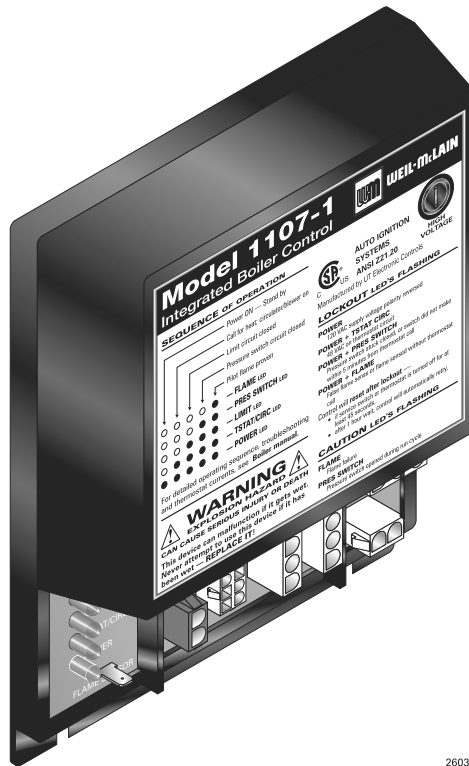

26036

Control indicator lights — LOCKOUT modes

See **Charts 1** through **7** in this Section for detailed troubleshooting procedures.

To reset control after a lockout, turn off power at the 120 VAC service switch or turn down all thermostats. Wait 45 seconds. Then restore power or call for heat.

POWER light flashing alone

Usually indicates reversed polarity of 120 VAC power wires.

POWER and TSTAT CIRC lights flashing

Usually indicates stray voltage on external thermostat circuit wires (usually due to miswired 3-wire zone valve).

POWER and PRESS SWITCH lights flashing

Usually indicates pressure switch is closed when it should not be, or pressure switch failed to close within 5 minutes of inducer starting.

POWER and FLAME lights flashing

Usually indicates false flame sense or flame sensed when it shouldn't be there.

Control indicator lights — NON-LOCKOUT modes

POWER light on and FLAME light flashing

Usually indicates pilot flame was not established within 15 seconds from application of spark. Control will flash light, but will continue to cycle indefinitely until flame is established or problem is corrected.

POWER light on and PRESS SWITCH light flashing

Usually indicates pressure switch opened during the run cycle.

Troubleshooting the control module

See **Figure 25**, page 46, for location of harness plug receptacles and plugs on the control module.



11c Troubleshooting — control module (continued)

Figure 25 Control module connections

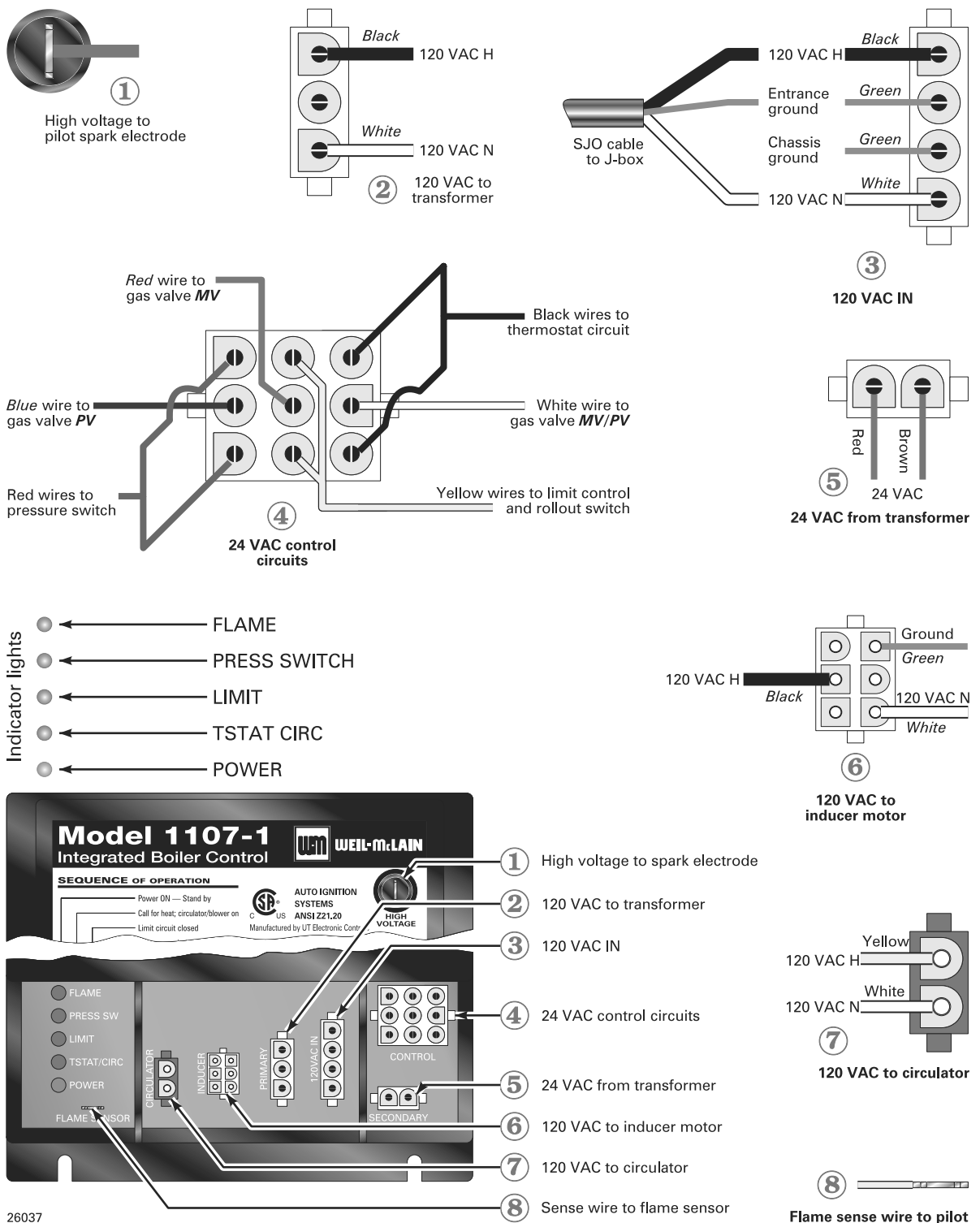



11d Troubleshooting — control module lights

CHART 1 — Troubleshooting POWER light status

— Usually indicates reversed 120 VAC polarity if POWER light flashes by itself —

⚠WARNING Electrical shock hazard — Wherever you see **▲TURN OFF POWER▲**, follow the instructions. Failure to follow instructions could result in severe personal injury, death or substantial property damage.

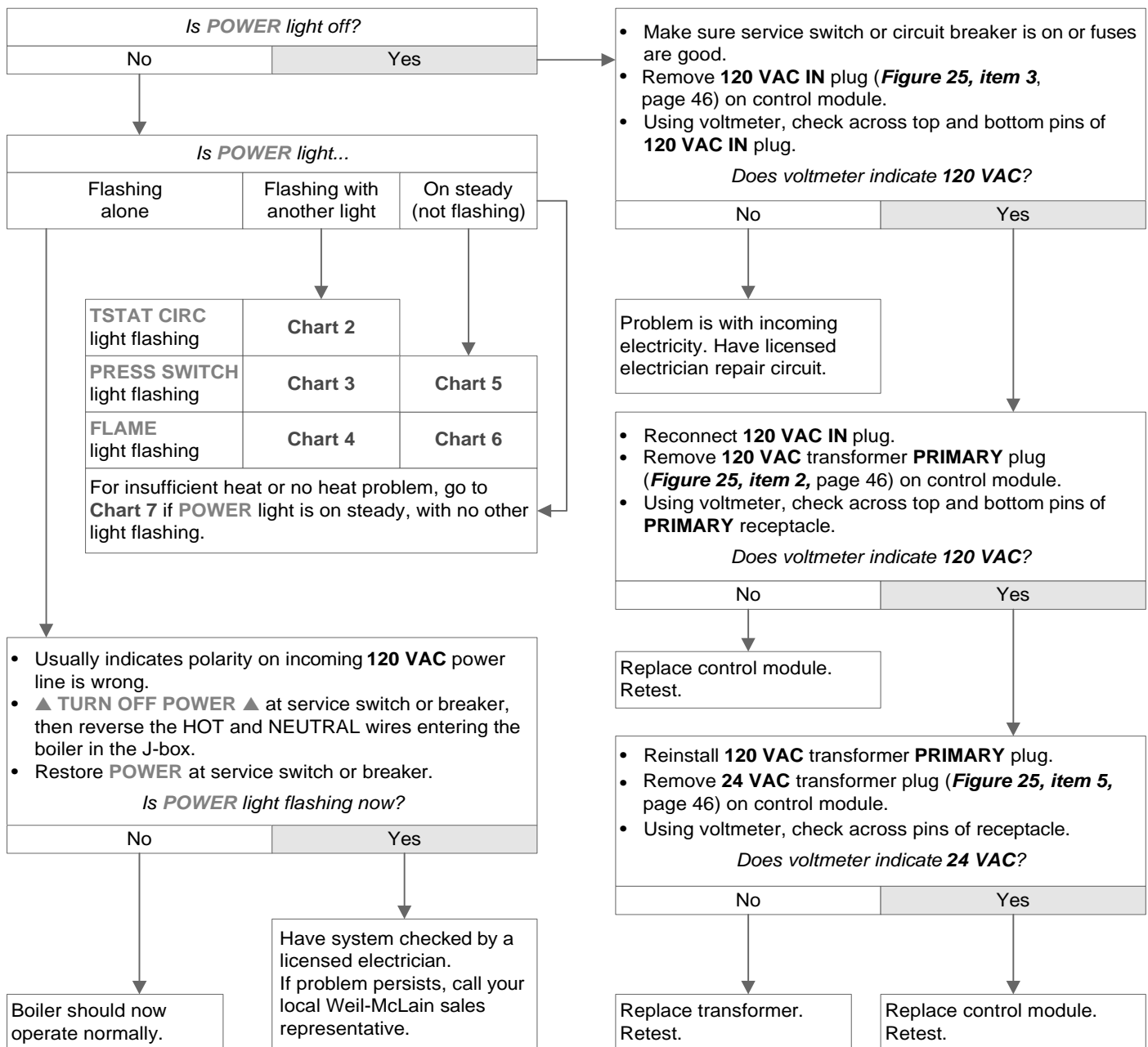



11d Troubleshooting — control module lights

CHART 2 — TSTAT CIRC & POWER lights flashing

— Usually indicates 48 VAC on thermostat circuit (stray voltage) —



WARNING Electrical shock hazard — Wherever you see **TURN OFF POWER**, follow the instructions. Failure to follow instructions could result in severe personal injury, death or substantial property damage.

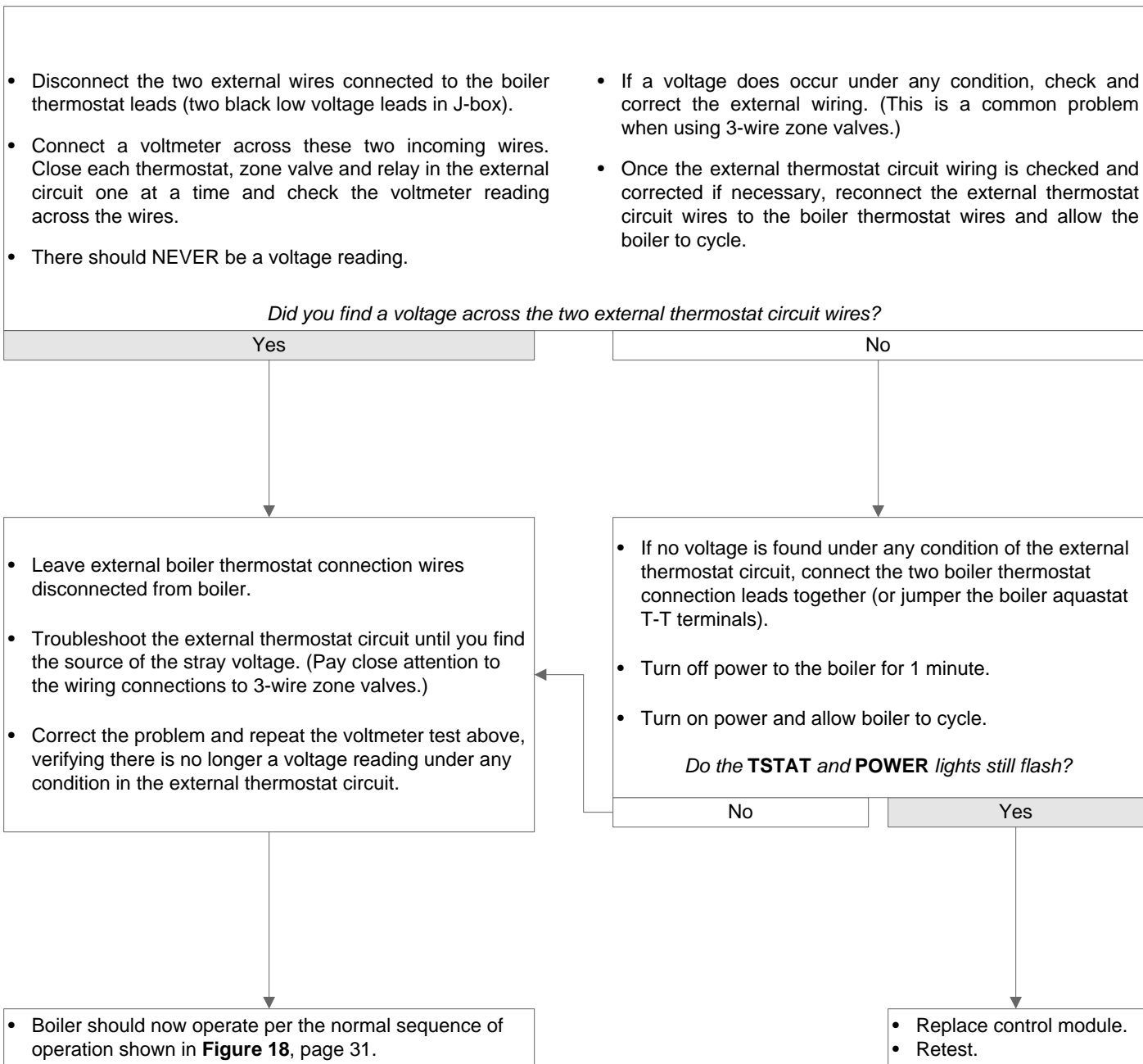



11d Troubleshooting — control module lights (cont.)

CHART 3 — PRESS SWITCH & POWER lights flashing

— Usually indicates pressure switch stuck closed or failed to make within 5 minutes —

WARNING Electrical shock hazard — Wherever you see **TURN OFF POWER**, follow the instructions. Failure to follow instructions could result in severe personal injury, death or substantial property damage.

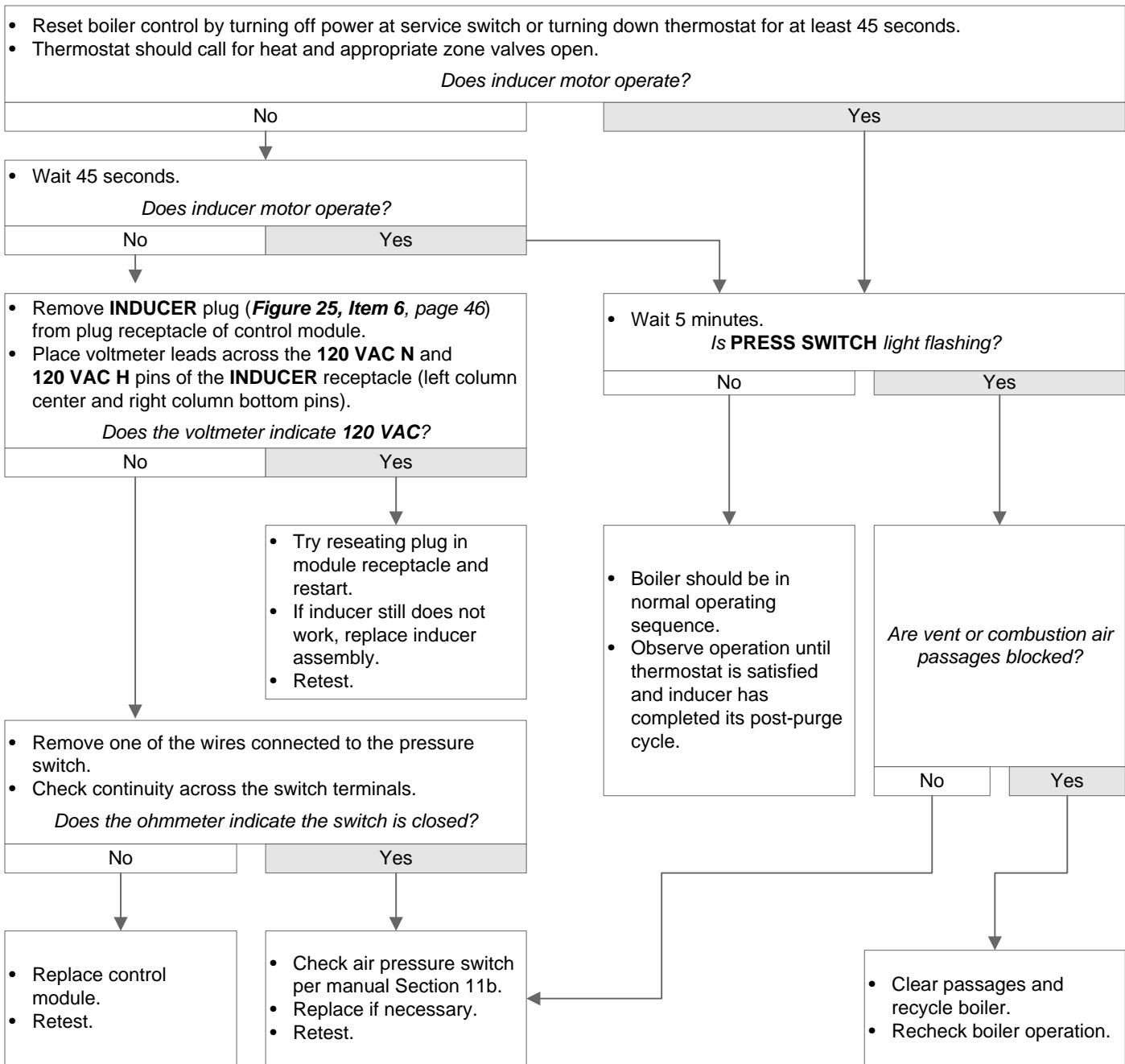



11d Troubleshooting — control module lights (cont.)

CHART 4 — FLAME & POWER lights flashing

— Usually indicates flame sensed when it shouldn't be there —

⚠ WARNING Electrical shock hazard — Wherever you see **⚡ TURN OFF POWER ⚡**, follow the instructions. Failure to follow instructions could result in severe personal injury, death or substantial property damage.

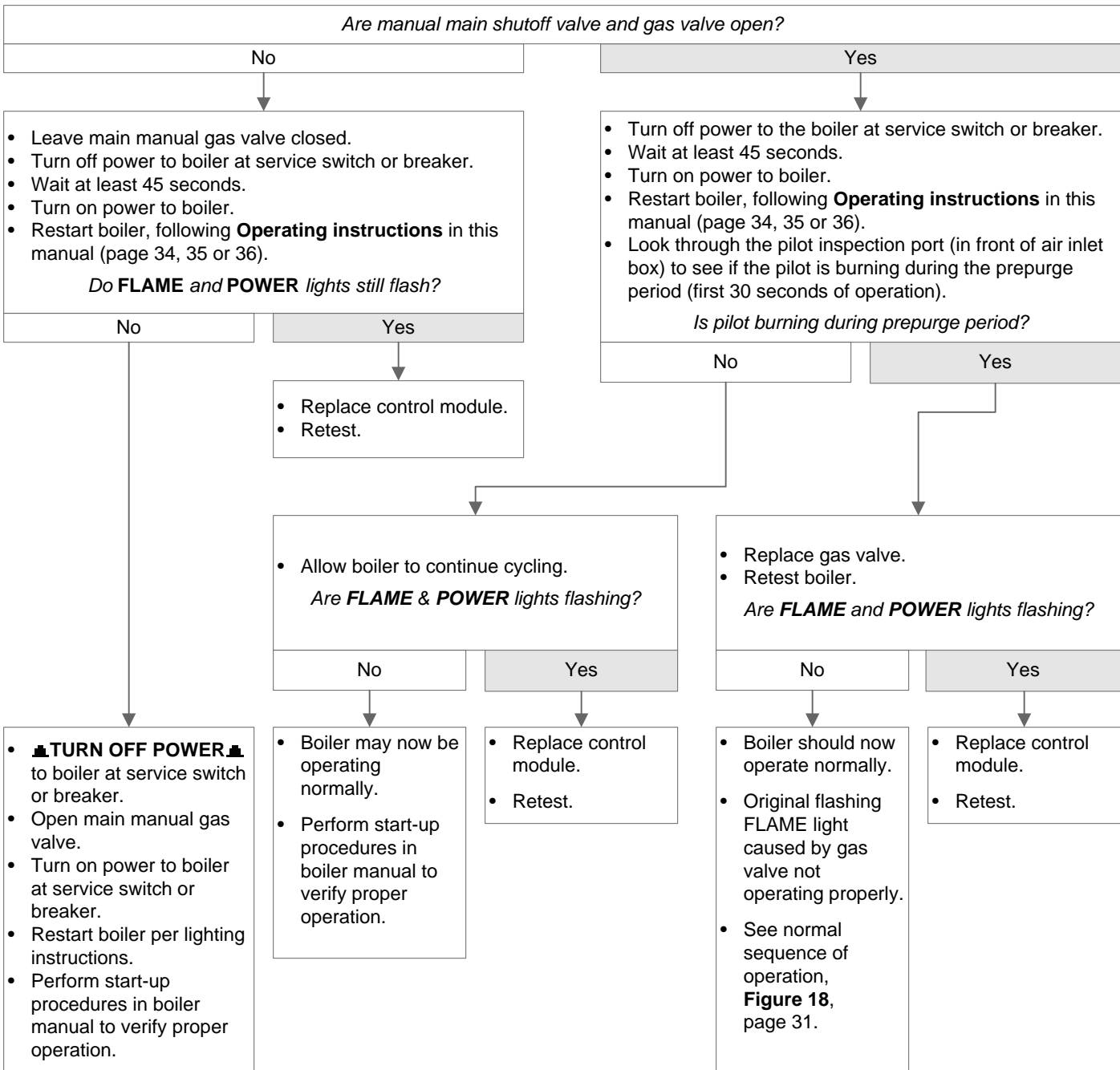

- **⚡ TURN OFF POWER ⚡** to boiler at service switch or breaker.
- Open main manual gas valve.
- Turn on power to boiler at service switch or breaker.
- Restart boiler per lighting instructions.
- Perform start-up procedures in boiler manual to verify proper operation.



11d Troubleshooting — control module lights (cont.)

**CHART 5 — FLAME light flashing and POWER light on steady
ALSO — Troubleshooting failure to establish main flame**

WARNING Electrical shock hazard — Wherever you see ▲ **TURN OFF POWER** ▲, follow the instructions. Failure to follow instructions could result in severe personal injury, death or substantial property damage.

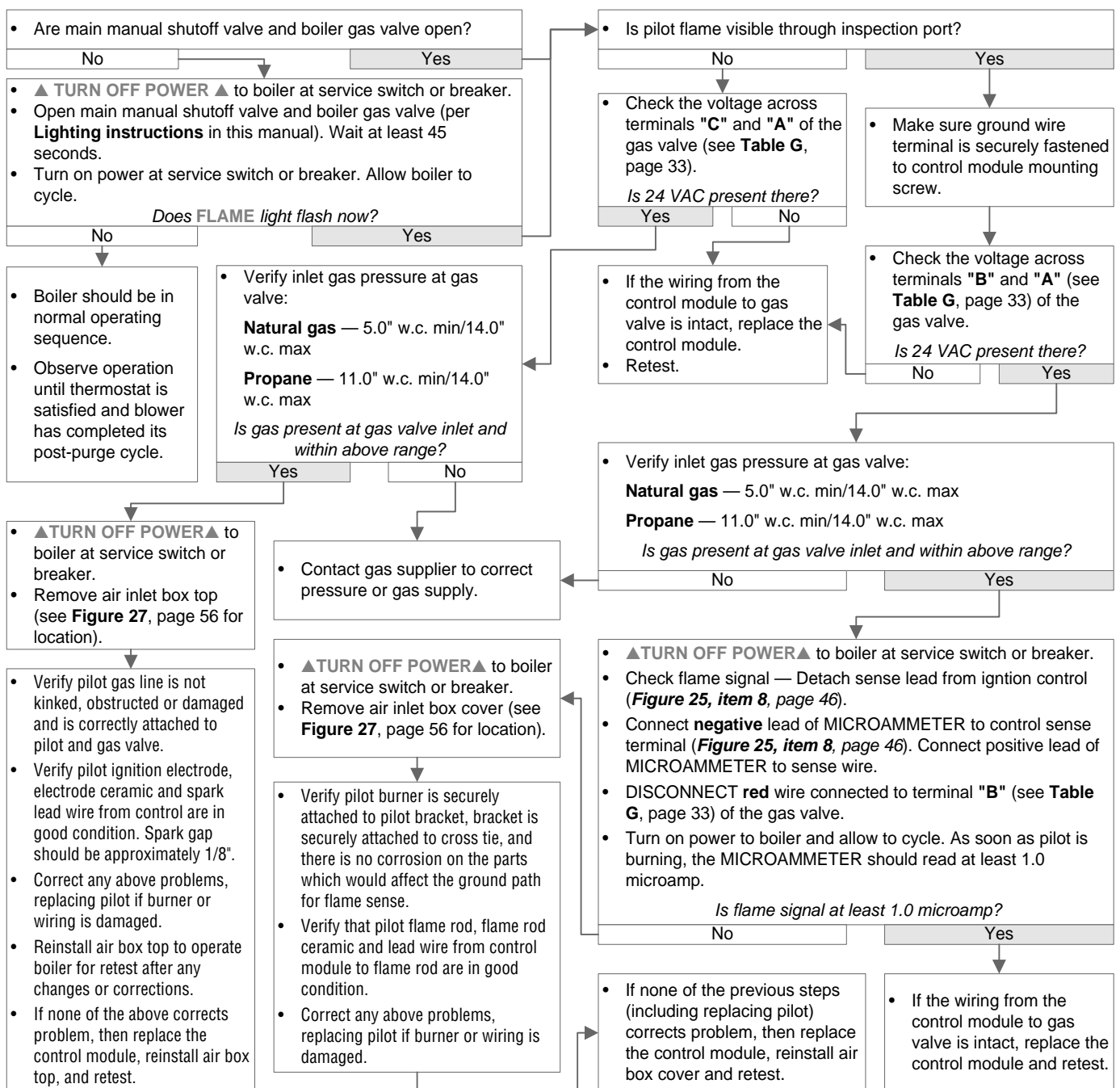



11d Troubleshooting — control module lights (cont.)

CHART 6 — PRESS SWITCH light flashing and POWER light on steady

— Usually indicates pressure switch opened during run cycle —
 — May also be caused by wind gusts in excess of 31 mph for non-direct vent sidewall-vented boilers —

WARNING Electrical shock hazard — Wherever you see **TURN OFF POWER**, follow the instructions. Failure to follow instructions could result in severe personal injury, death or substantial property damage.

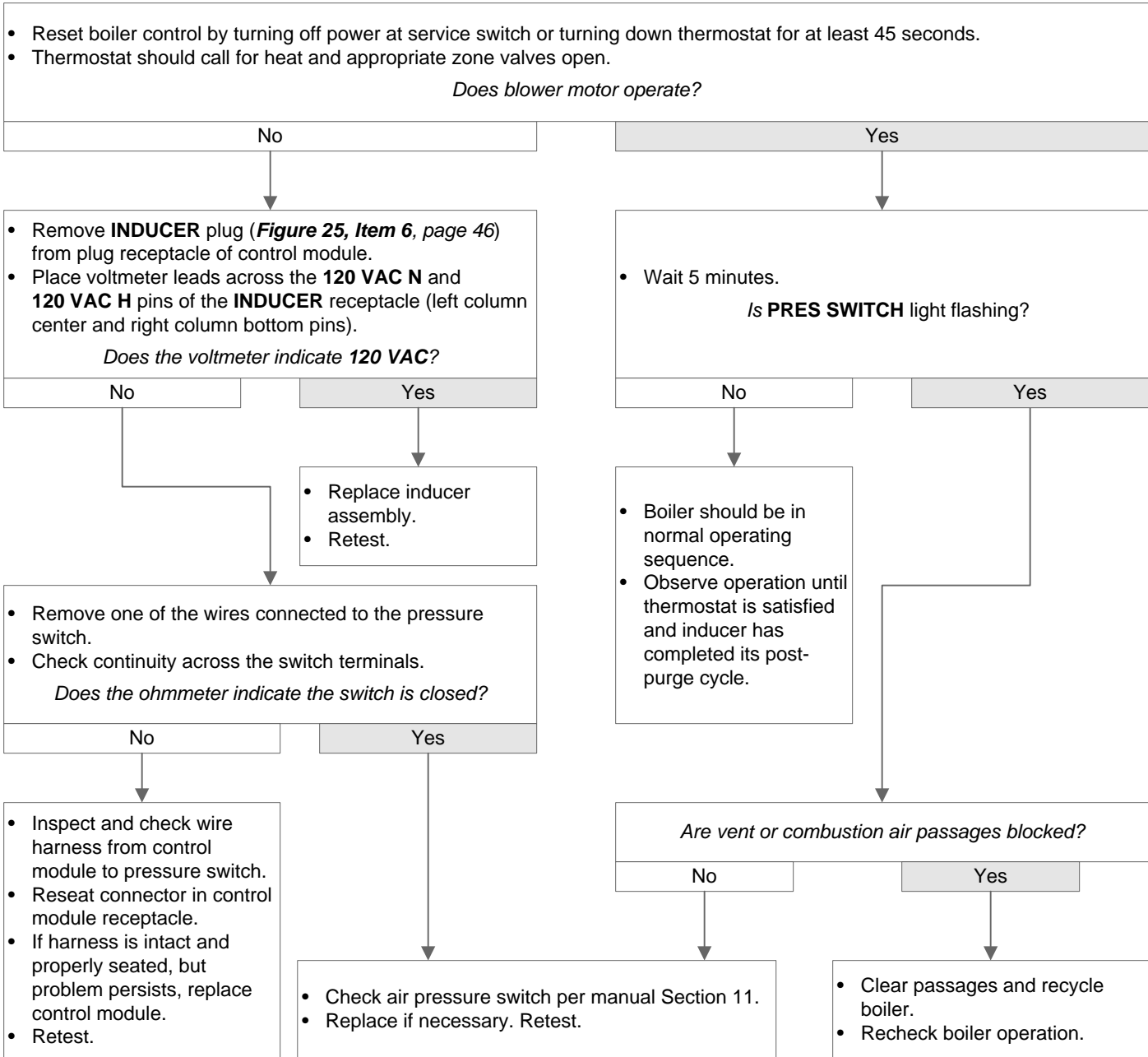



11d Troubleshooting — control module lights (cont.)

CHART 7 — Insufficient heat or no heat to system (POWER light on steady)

⚠ WARNING Electrical shock hazard — Wherever you see **⚡TURN OFF POWER⚡**, follow the instructions. Failure to follow instructions could result in severe personal injury, death or substantial property damage.

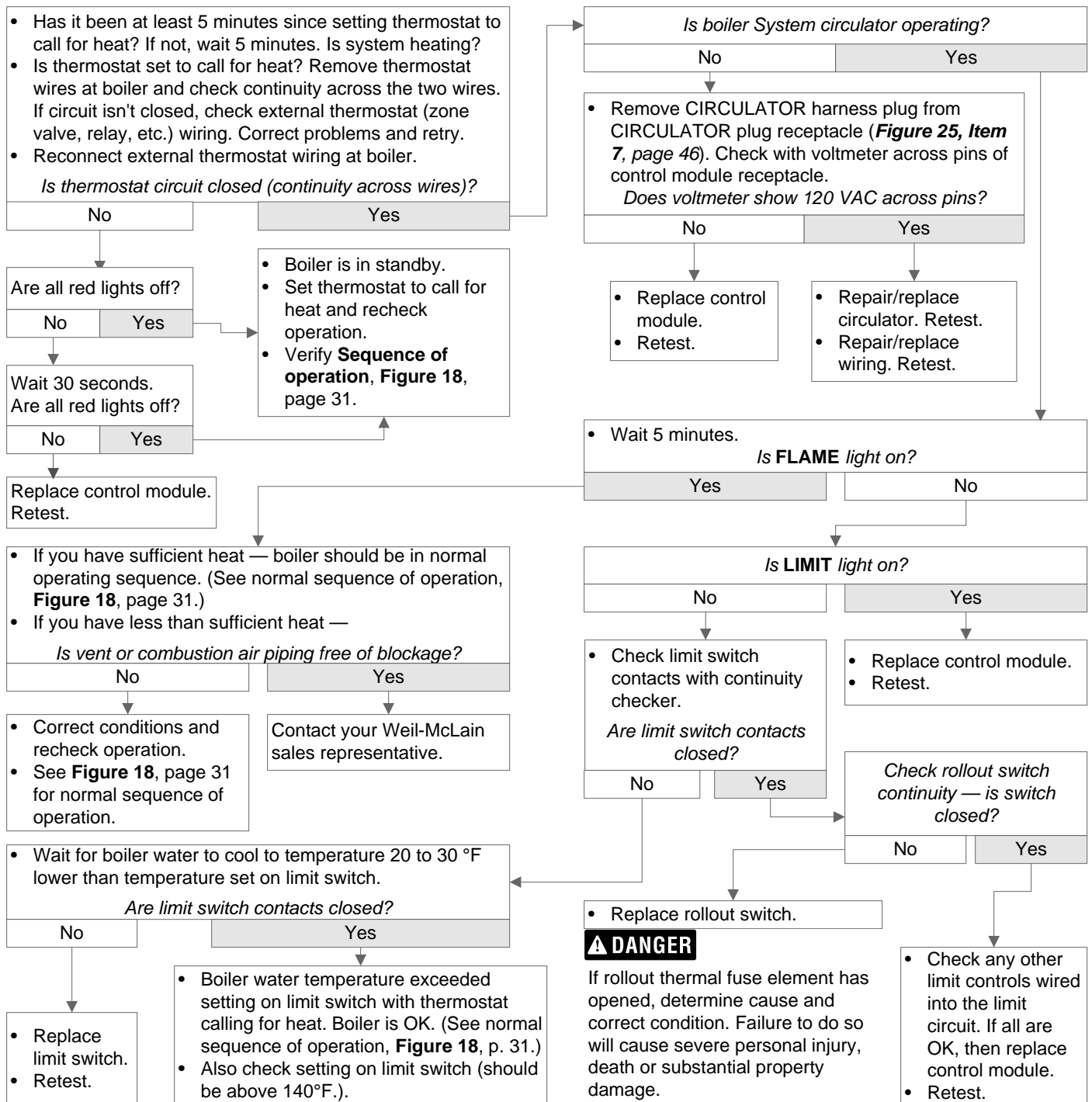



12a Replacement parts

Section assembly	55
Base	56
Jacket	58
Trim	60
Controls	61

▲WARNING

Replacement parts must be purchased through a local Weil-McLain distributor. When ordering, specify boiler model and size and include description and part number of replacement part. Results from using modified or other manufactured parts will not be covered by warranty and may damage boiler or impair operation.

NOTICE

Weil-McLain part numbers are found in **Weil-McLain Boilers and Controls Repair Parts Lists**.

▲WARNING

The boiler contains ceramic fiber and fiberglass materials. Use care when handling these materials per instructions on **page 64** of this manual. Failure to comply could result in severe personal injury.



12b Replacement parts — section assembly

Figure 26 Section assembly

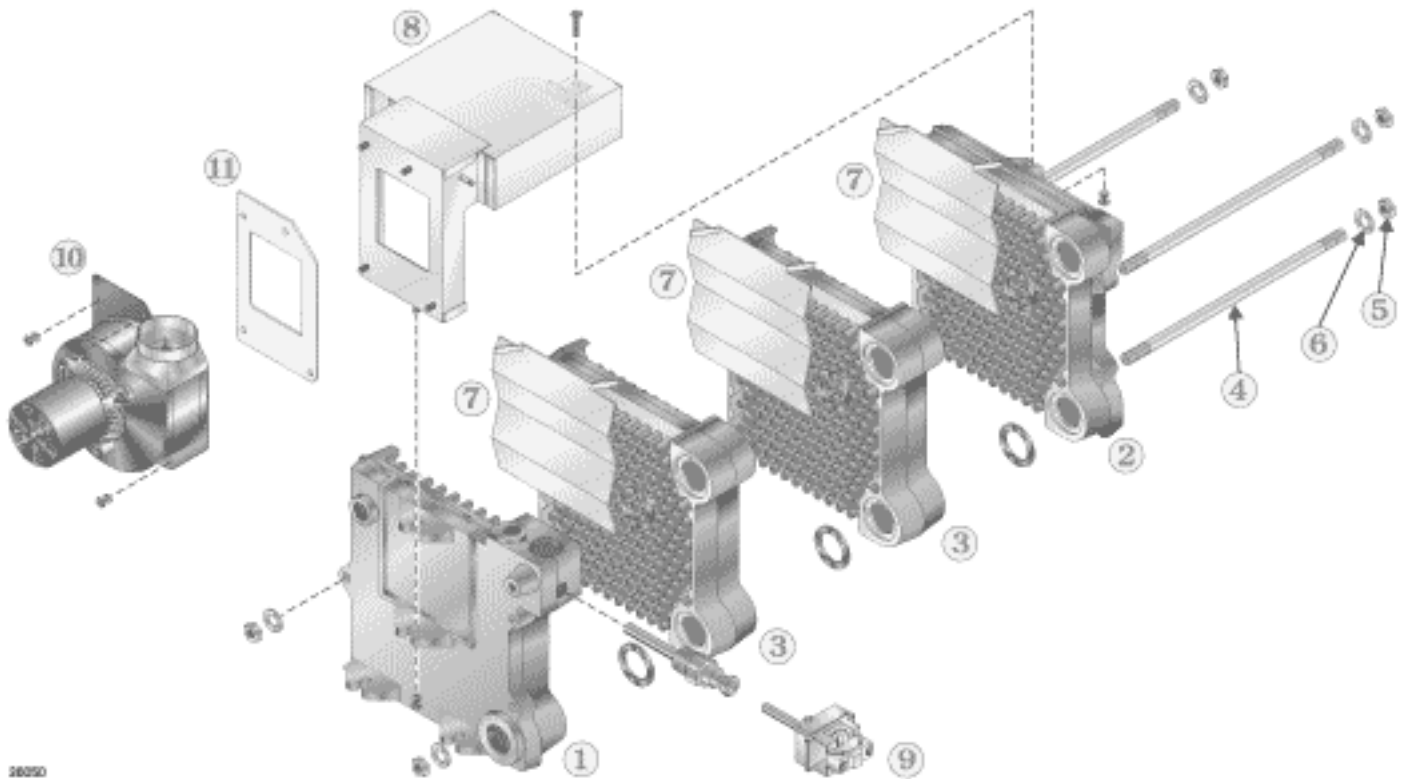

26020

Item number	Description	Weil-McLain part number
1	End section, left hand, 51124	311-103-830
2	End section, right hand 51128	311-103-821
3	Intermediate section, 51125	311-103-818
not shown	Replacement section assembly	CGs-3 321-114-345 CGs-4 321-114-346 CGs-5 321-114-347 CGs-6 321-114-348
not shown	Section replacement kit, includes seals and sealant for 1 joint	381-354-527
4	Tie rod, 7/16" without nut (3 per boiler):	CGs-3 560-234-500 CGs-4 560-234-501 CGs-5 560-234-502 CGs-6 560-234-503
5	Nut, 7/16" (2 per tie rod)	561-928-235
6	Washer, 7/16" (1 per tie rod)	562-248-684
7	Radiation plate (1 per joint)	460-003-700
8	Collector hood and transition assembly	CGs-3 450-020-511 CGs-4 450-020-512 CGs-5 450-020-513 CGs-6 450-020-514
9	High limit, 30' differential, with well	Honeywell L4080D1036 White-Rodgers 11B81-3 510-312-250
10	Inducer fan assembly kit, includes inducer fan assembly, gasket and nuts	381-356-499
11	Gasket, inducer	590-317-627

12c Replacement parts – base

Figure 27 Base assembly

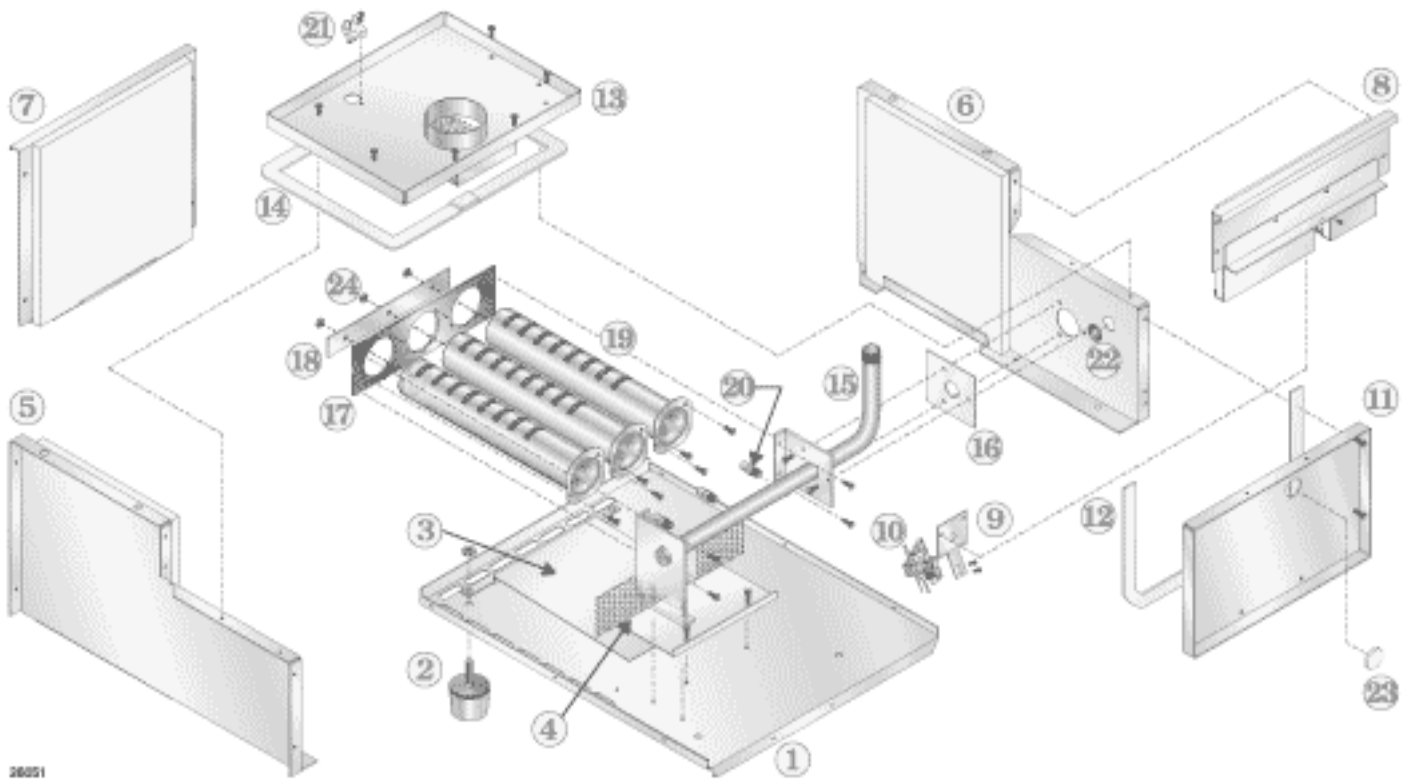

26251



12c Replacement parts — base (continued)

Item	Description		Weil-McLain part number
	Base insulation kit (includes insulation for all base parts above plus gasket material needed between block assembly and base)	CGs-3 CGs-4 CGs-5 CGs-6	381-356-515 381-356-516 381-356-517 381-356-518
	Base assembly kit (includes base panels items 1, 2, 3, 4, 5, 6, 7, 8, 11, 13, 22 and 23 plus insulation, Air box gaskets, and hardware)	CGs-3 CGs-4 CGs-5 CGs-6	381-356-522 381-356-523 381-356-524 381-356-525
	Inlet air box top panel kit (includes items 13 and 14)	CGs-3 CGs-4 CGs-5 CGs-6	381-356-501 381-356-502 381-356-503 381-356-504
	Inlet air box front panel kit (includes items 11, 12 and 23)	CGs-3 CGs-4 CGs-5 CGs-6	381-356-508 381-356-509 381-356-510 381-356-511
1	Base pan (in Base assembly)		
2	Boiler leg kit		550-320-219
3	Heat shield (in Base assembly)		
4	Burner baffle (in Base assembly)		
5	Base left side panel (in Base assembly)		
6	Base right side panel (in Base assembly)		
7	Base back panel (in Base assembly)		
8	Base front cross-tie assembly (in Base assembly)		
9	Pilot bracket		450-003-689
10	Pilot burner assembly — Natural gas Pilot burner assembly — Propane gas		511-330-080 511-330-081
11	Inlet air box front panel (in Inlet air box front panel kit)		
12	Inlet air box front panel gasket (Use Gasket kit)		
13	Inlet air box top panel (in Inlet air box top panel kit)		
14	Inlet air box top panel gasket (Use Gasket kit)		
15	Manifold (per size)	CGs-3 CGs-4 CGs-5 CGs-6	591-126-722 591-126-723 591-126-724 591-126-725
16	Manifold mounting gasket		590-317-406
17	Burner mounting panel	CGs-3 CGs-4 CGs-5 CGs-6	450-003-690 450-003-691 450-003-692 450-003-693
18	Rear spacer strip	CGs-3 CGs-4 CGs-5 CGs-6	550-320-160 550-320-161 550-320-162 550-320-163
19	Burner		512-200-076
20	Burner orifice — Natural gas, sea level Burner orifice — Propane gas, sea level		560-529-077 560-529-078
21	Thermal fuse element		512-050-230
22	Grommet for sealing pilot tubing/wiring opening to Air box		591-850-064
23	Inspection port clear plug		591-491-216
24	Hex nut for burner end stud, 5 mm		550-320-170
	Gasket (for Air inlet box covers), 8-foot length		590-317-400



12d Replacement parts — jacket

Figure 28 Jacket assembly

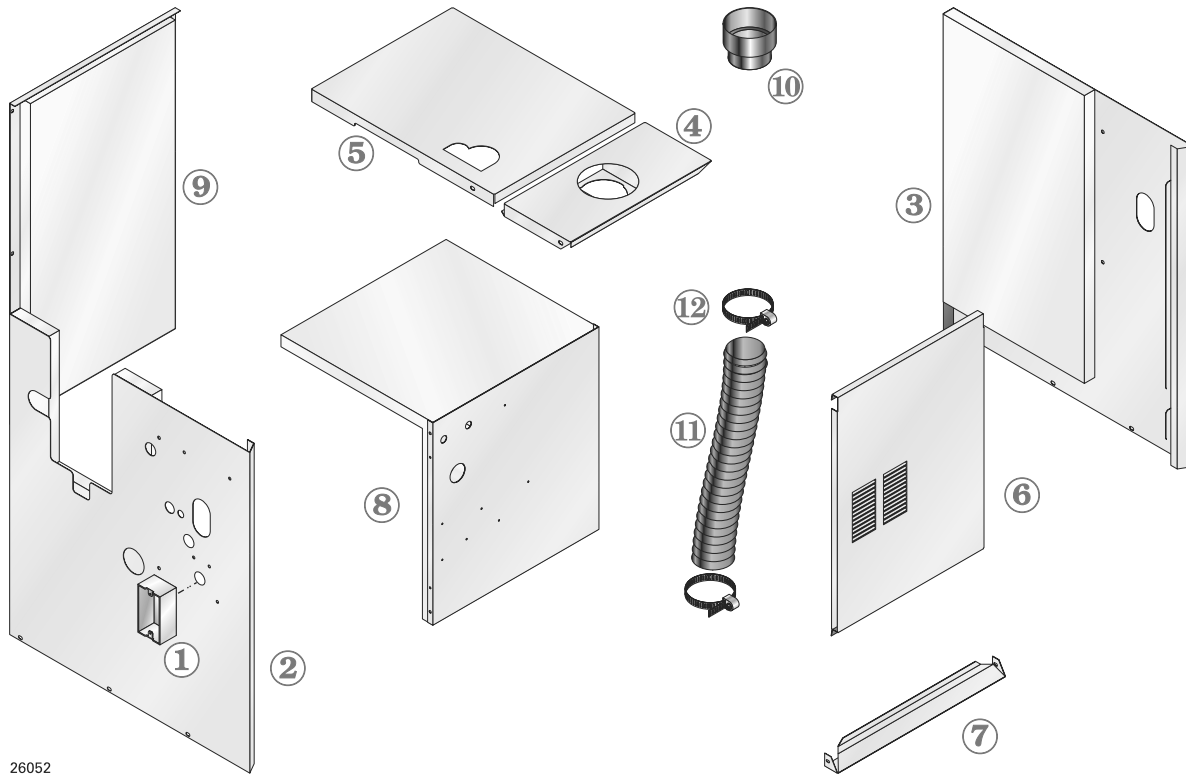

26052



12d Replacement parts — jacket (continued)

Boiler Model	1	2		3	4	5	6	Boiler Model
	Junction box, 2 x 4	Panel, left side, with insulation		Panel, right side, with insulation	Panel, top front, with insulation	Panel, top rear, with insulation	Panel, door	
		Natural Gas	Propane Gas					
Weil-McLain part number								
CGs-3 CGs-4 CGs-5 CGs-6	(Available at local supply house)	381-355-701 381-355-708 381-355-715 381-355-722	381-355-729 381-355-732 381-355-735 381-355-738	381-355-699 381-355-699 431-223-311 431-223-311	381-355-403 381-355-413 381-355-420 381-355-427	381-355-706 381-355-713 381-355-720 381-355-727	381-355-707 381-355-714 381-355-721 381-355-728	CGs-3 CGs-4 CGs-5 CGs-6
Boiler Model	7	8	9	10	11	12	Not shown	Boiler Model
	Cross tie, bottom front	Panel, interior, with insulation	Panel, rear, with insulation	Air inlet fitting	Inlet air hose	Hose clamp 3"	Gold touch-up paint	
	Weil-McLain part number							
CGs-3 CGs-4 CGs-5 CGs-6	431-223-325 431-223-326 431-223-327 431-223-328	381-355-540 381-355-552 381-355-559 381-355-566	431-223-300 431-223-301 431-223-302 431-223-303	560-907-635	562-302-573	591-850-068	592-000-000	CGs-3 CGs-4 CGs-5 CGs-6



12e Replacement parts — trim

Figure 29 Trim assembly

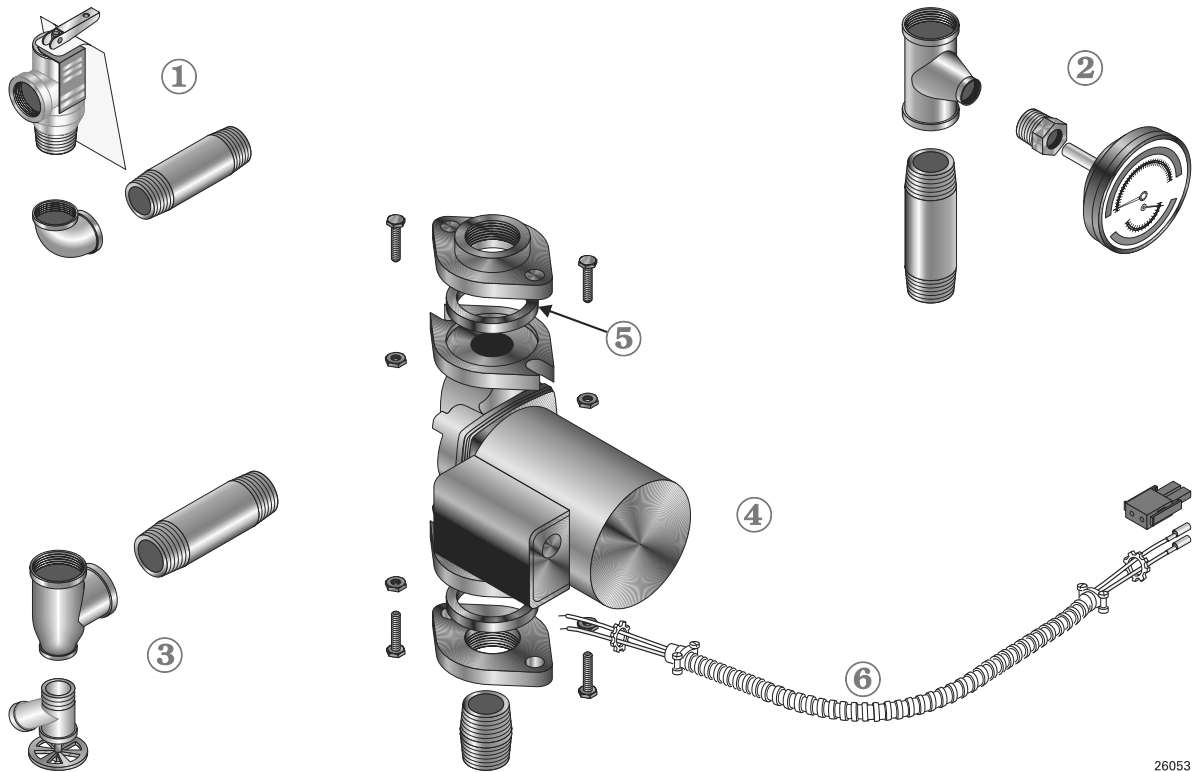

26053

Item number	Description	Manufacturer	Manufacturer's part number	Weil-McLain part number
1	Pressure relief valve, ASME, 30 PSIG, 3/4" male inlet Pressure relief valve, ASME, 30 PSIG, 3/4" female inlet <i>(Fittings shown are factory-installed on boiler.)</i>	Conbraco Watts Conbraco Watts	10-407-10 M330 10-408-05 335	511-546-920 511-546-924
2	Combination pressure-temperature gauge, 3 1/8" diameter, short shank <i>(Fittings shown are shipped loose with boiler.)</i>	Weil-McLain		380-000-000
3	Drain valve, 3/4" <i>(Fittings shown are included with boiler.)</i>	Conbraco Hammond Valve Matco-Norca Watts	31-606-01 710 205F04 BD-2C	511-210-423 511-246-392 511-246-392 511-246-392
4	Circulator <i>(Fittings shown are shipped loose with boiler.)</i>	Bell & Gossett Grundfos Taco	NRF-22-103253 UP15-42FR-TB4 007	511-405-118 511-405-126 511-405-113
5	Circulator gasket, universal (2 per boiler)	Weil-McLain		590-317-535
not shown	Circulator hardware kit, includes: 1 flange, 2 nuts, 2 screws, 1 gasket — 1" NPT — CGs-3 through CGs-5 1 1/4" NPT — CGs-6	Weil-McLain		381-300-494 381-300-495
6	Circulator wiring harness kit, with Molex <i>(loose)</i>			381-354-528



12f Replacement parts — controls

Figure 30 Gas control assembly

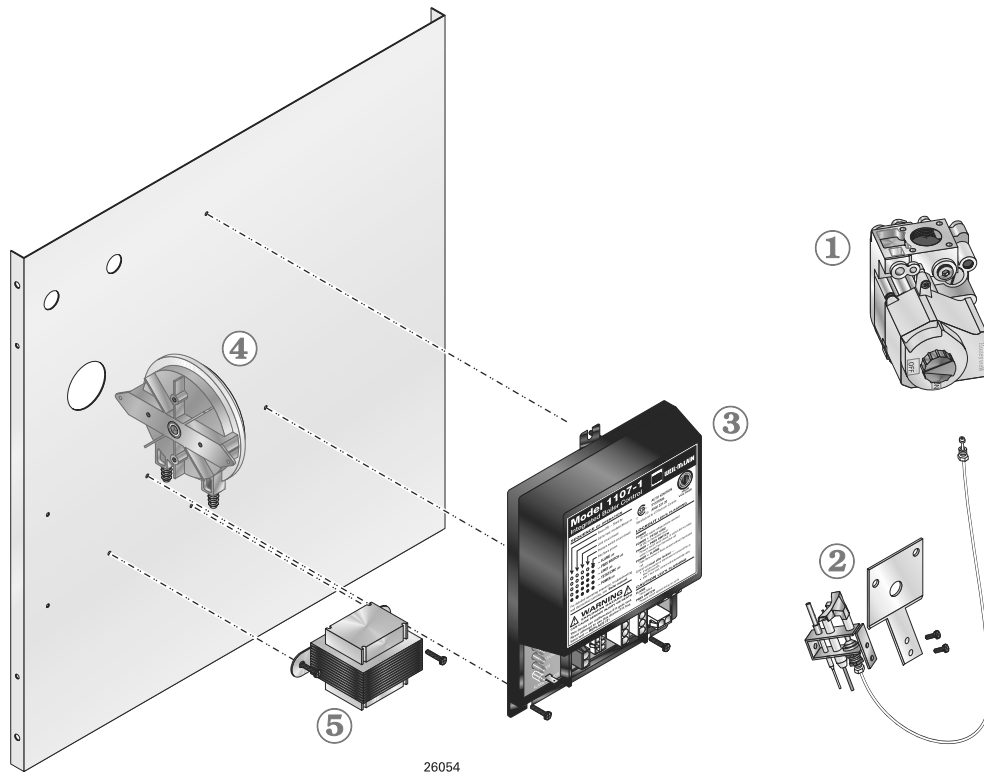

Item number	Description	Manufacturer	Manufacturer's part number	Weil-McLain part number
Natural gas components				
1	Gas valve, ½" x ½", CGs-3 through CGs-6	Honeywell	VR8204A2001	511-044-381
2	Pilot assembly kit with orifice and aluminum pilot gas tubing	Weil-McLain		511-330-080
Propane gas components				
1	Gas valve, ½" x ½", CGs-3 through CGs-6	Honeywell	VR8204M2701	511-044-354
2	Pilot assembly kit with orifice and aluminum pilot gas tubing	Weil-McLain		511-330-081
Natural gas and propane gas components				
3	Control module	United Technologies	1107-1	511-330-090
not shown	Wiring harness	Weil-McLain		591-319-795
4	Air pressure switch 1.79 I.W.C. — CGs-3 1.48 I.W.C. — CGs-4 1.22 I.W.C. — CGs-5 0.95 I.W.C. — CGs-6	Tri-Delta	PPS10171-3013 PPS10171-3014 PPS10171-3015 PPS10171-3016	511-624-401 511-624-402 511-624-403 511-624-404
5	Control transformer			511-842-370
not shown	Tubing, air pressure switch, 0.12 I.D. silicone red, to collector hood white, to transition	Lydall		590-317-650 590-317-651



13a Dimensions

Figure 31 Dimensional drawing

- ① Supply piping (note 1)
- ② Return piping (note 1)
- ③ Relief valve, 3/4" NPT
- ④ 1/2" NPT to expansion tank/air vent
- ⑤ 3" Diameter vent

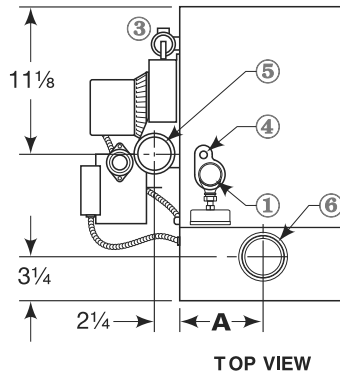

- ⑥ 3"/3 1/2" Dia. air pipe connection
- ⑦ Gas supply piping
- ⑧ Drain valve
- ⑨ Gas supply entrance (right or left side)
- ⑩ Pressure/temperature gauge

Note 1: Boiler supply and return tapings are both 1/4" NPT. See **Table 3**, page 14 for recommended system supply and return piping sizes.

Note 2: Boiler circulator is shipped loose. Circulator may be mounted on either boiler supply or return piping. Circulator flange provided with boiler is same size as recommended pipe size in **Table 3**, page 14.

ALL DIMENSIONS IN INCHES

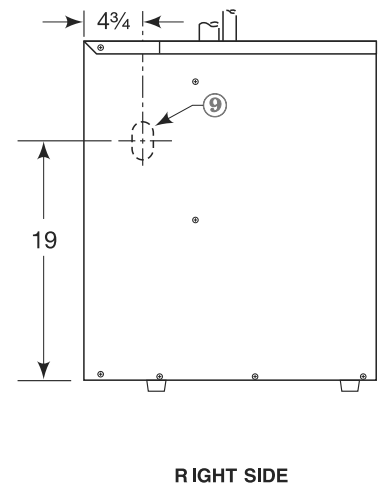
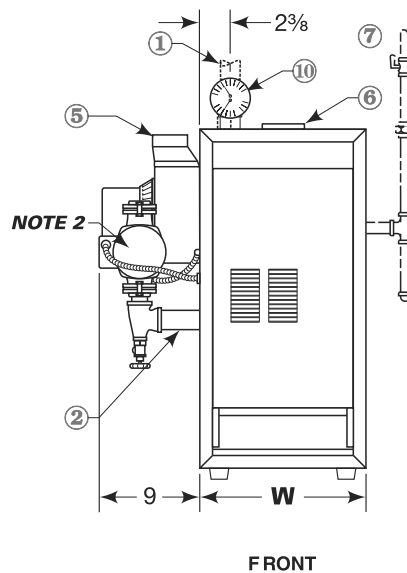
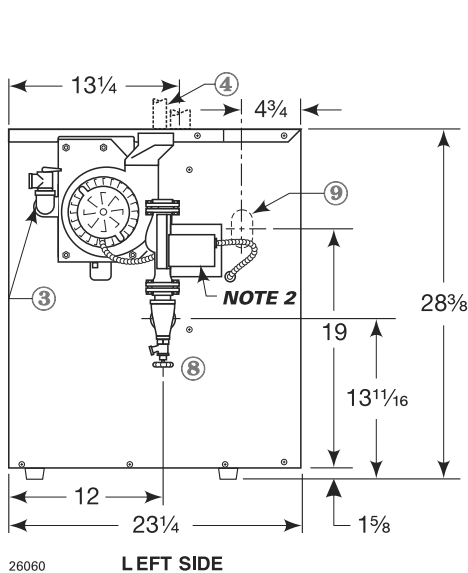

26060

Boiler model number	Supply tapping (inches NPT)	Return tapping (inches NPT)	Gas connection size Note 3 (inches NPT)	Gas manifold size Note 3 (inches NPT)	" A " Air inlet pipe center (inches)	" W " Jacket width (inches)
CGs-3	1 1/4	1 1/4	1/2	1/2	6 1/2	13
CGs-4	1 1/4	1 1/4	1/2	1/2	8	16
CGs-5	1 1/4	1 1/4	1/2	1/2	9 1/2	19
CGs-6	1 1/4	1 1/4	1/2	1/2	11	22

Note 3: Gas piping from meter to boiler to be sized per local utility requirements.



13b Ratings



DOE



(Note 5)

Table 7 Boiler ratings

Boiler model number	DOE Heating capacity (Btuh)	0-2,000 feet		2,000-4,500 feet		Net I=B=R ratings (Btuh)	Boiler water content (gallons)	DOE Seasonal efficiency (% AFUE)	Vent size
		Input (Btuh)	Output (Btuh)	Input (Btuh)	Output (Btuh)				
(Note 1)	(Note 2)					(Note 3)		(Note 5)	(Note 4)
CGs-3 (Note 5)	57,000	67,000	57,300	60,300	51,600	50,000	1.5	85.3	3"
CGs-4	85,000	100,000	85,000	90,000	76,500	74,000	2.1	84.6	3"
CGs-5	112,000	133,000	112,400	119,000	100,600	97,000	2.7	84.0	3"
CGs-6	140,000	167,000	140,300	150,300	126,300	122,000	3.3	83.4	3"

Notes

1. Add "PIN" for natural gas boiler - "PIL" for propane gas boiler.
2. Based on standard test procedures prescribed by the United States Department of Energy.
3. Net I=B=R ratings are based on net installed radiation of sufficient quantity for the requirements of the building and nothing need be added for normal piping and pickup. Ratings are based on a piping and pickup allowance of 1.15. An additional allowance should be made for unusual piping and pickup loads.
4. CGs boilers require special venting, consistent with Category III or IV boiler. Use only the vent materials and methods specified in CGs vent supplements. CGs boilers may be direct-vented (using 3" diameter air piping) as specified in the direct vent supplements.
5. As an Energy Star Partner, Weil-McLain has determined that the CGs-3 meets the Energy Star guidelines for energy efficiency.

NOTICE

CGs boilers for residential radiant panel systems, converted gravity heating systems or other low water temperature applications should be installed with balancing valves and bypass piping equal to the supply and return size to avoid excessive flue gas condensation due to lower operating water temperatures. For alternate piping, contact your Weil-McLain sales office. CSA design certified for installation on combustible flooring. Tested for 50 psi working pressure.



Handling ceramic fiber and fiberglass materials

REMOVAL OF COMBUSTION CHAMBER LINING OR BASE PANELS

WARNING

The combustion chamber lining or base insulation panels in this product contain ceramic fiber materials. Ceramic fibers can be converted to cristobalite in very high temperature applications. The International Agency for Research on Cancer (IARC) has concluded, "Crystalline silica inhaled in the form of quartz or cristobalite from occupational sources is carcinogenic to humans (Group 1).":

Precautionary measures

- Avoid breathing fiberglass dust and contact with skin or eyes.
 - Use NIOSH certified dust respirator (N95). This type of respirator is based on the OSHA requirements for fiberglass wool at the time this document was written. Other types of respirators may be needed depending on the job site conditions. Current NIOSH recommendations can be found on the NIOSH web site at <http://www.cdc.gov/niosh/homepage.html>. NIOSH approved respirators, manufacturers, and phone numbers are also listed on this web site.
 - Wear long-sleeved, loose fitting clothing, gloves, and eye protection.
- Apply enough water to the combustion chamber lining or base insulation to prevent airborne dust.
- Remove combustion chamber lining or base insulation from the boiler and place it in a plastic bag for disposal.
- Wash potentially contaminated clothes separately from other clothing. Rinse clothes washer thoroughly.

NIOSH stated First Aid.

- Eye: Irrigate immediately.
- Breathing: Fresh air.

REMOVAL OF FIBERGLASS WOOL

or

INSTALLATION OF FIBERGLASS WOOL, COMBUSTION CHAMBER LINING OR BASE PANELS:

WARNING

This product contains fiberglass jacket insulation and ceramic fiber materials in combustion chamber lining or base panels in gas fired products. Airborne fibers from these materials have been listed by the State of California as a possible cause of cancer through inhalation.

Precautionary measures

- Avoid breathing fiberglass dust and contact with skin or eyes.
 - Use NIOSH certified dust respirator (N95). This type of respirator is based on the OSHA requirements for fiberglass wool at the time this document was written. Other types of respirators may be needed depending on the job site conditions. Current NIOSH recommendations can be found on the NIOSH web site at <http://www.cdc.gov/niosh/homepage.html>. NIOSH approved respirators, manufacturers, and phone numbers are also listed on this web site.
 - Wear long-sleeved, loose fitting clothing, gloves, and eye protection.
- Operations such as sawing, blowing, tear out, and spraying may generate airborne fiber concentration requiring additional protection.
- Wash potentially contaminated clothes separately from other clothing. Rinse clothes washer thoroughly.

NIOSH stated First Aid.

- Eye: Irrigate immediately.
- Breathing: Fresh air.

Free Manuals Download Website

<http://myh66.com>

<http://usermanuals.us>

<http://www.somanuals.com>

<http://www.4manuals.cc>

<http://www.manual-lib.com>

<http://www.404manual.com>

<http://www.luxmanual.com>

<http://aubethermostatmanual.com>

Golf course search by state

<http://golfingnear.com>

Email search by domain

<http://emailbydomain.com>

Auto manuals search

<http://auto.somanuals.com>

TV manuals search

<http://tv.somanuals.com>