

WEIL-McLAIN

MODELS HE (Series 2) AND VHE (Series 2)

NATURAL GAS-FIRED
INDUCED DRAFT BOILERS

**SUPPLEMENTAL
INSTRUCTIONS**
WITH WHITE-RODGERS
CYCLE-PILOT® SYSTEM FOR
NATURAL GAS-FIRED BOILERS

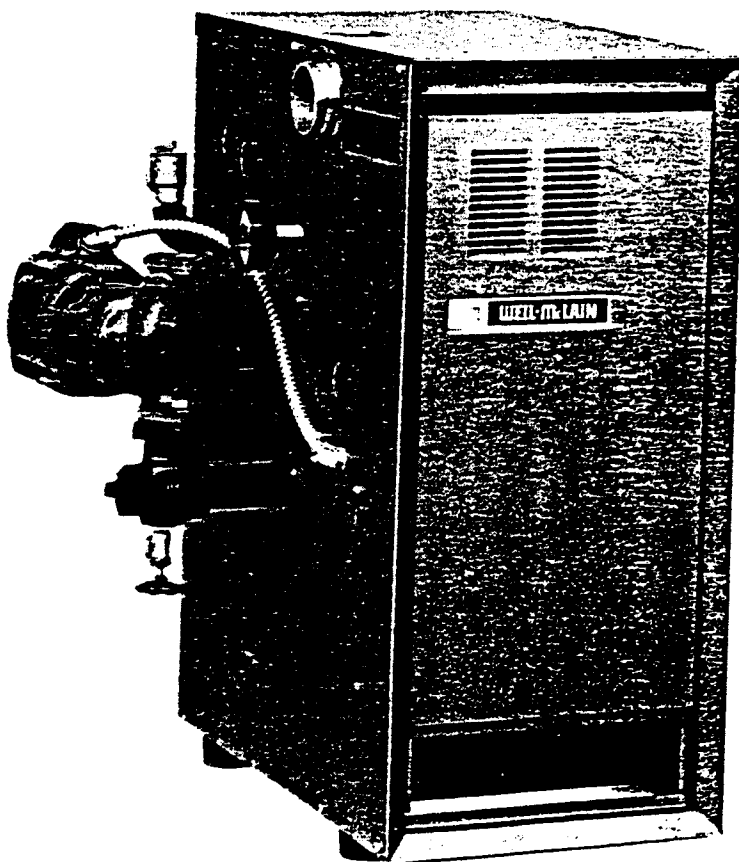

MODEL HE (Series 2)

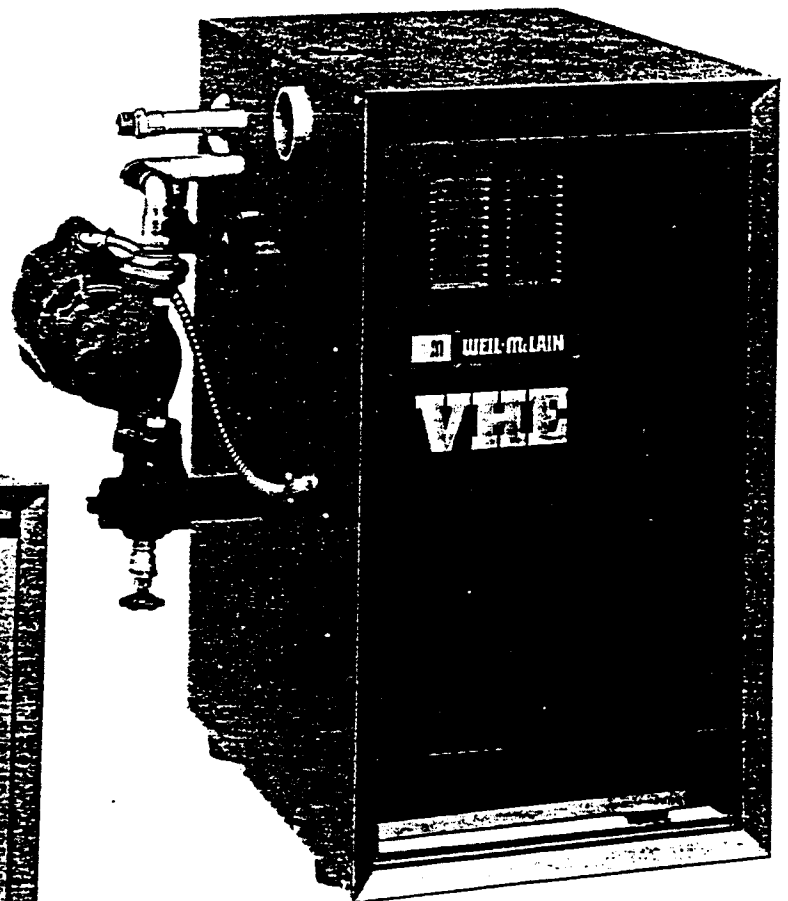

MODEL VHE (Series 2)

NATURAL GAS

Part No. 550-141-422/0983WP

HE (Series 2) and VHE (Series 2) with White-Rodgers Cycle-Pilot® for Natural Gas Firing

TABLE OF CONTENTS

Base Assembly Parts Description
With White-Rodgers Cycle-Pilot®
For Natural Gas Firing 2

Ignition System Components 3

Boiler Equipment Components 4

Sequence of Operation 4

Schematic Wiring Diagram 5

Ladder Wiring Diagram 5

Trouble Shooting Procedure 6

Checking The Pressure Differential Switch 6

Trouble Shooting Charts 7-11

**HE (Series 2) and VHE (Series 2)
Base Assembly Parts Description
With White-Rodgers Cycle-Pilot®
For Natural Gas Firing**

FIGURE NO.	MODEL NO. PART DESCRIPTION	HE & VHE 3 QTY. PART NO.	HE & VHE 4 QTY. PART NO.	HE & VHE 5 QTY. PART NO.	HE & VHE 6 QTY. PART NO.
3	Relite Control	1 511-330-111	1 511-330-111	1 511-330-111	1 511-330-111
7	Gas Valve Assembly	1 511-044-288	1 511-044-288	1 511-044-288	1 511-044-288
■	Orifice, Main Burner Natural Gas No. 47 Drill	4 560-528-992	6 560-528-992	8 560-528-992	10 560-528-992

■ Not Shown.

NOTE: PARTS LISTED ABOVE ARE FOR BOILERS FIRED WITH NATURAL GAS ONLY. FOR ADDITIONAL PARTS COMMON TO NATURAL AND PROPANE GASES REFER TO BOILER MANUAL.

IMPORTANT: When calling or writing about the boiler, PLEASE GIVE THE MODEL, SERIES, AND C.P. NUMBERS, located on the boiler.

Any reuse or reproduction of the artwork and copy in this manual is strictly prohibited without the written consent of Weil-McLain.

WEIL-McLAIN

Michigan City, Indiana 46360 ■ A Marley Company



in Canada: Weilm Canada LTD LTEE 126 East Dr. Brampton Ontario L6T 1C2



**HE (Series 2) and VHE (Series 2)
WHITE-RODGERS CYCLE-PILOT® IGNITION SYSTEM COMPONENTS
FOR NATURAL GAS FIRING**

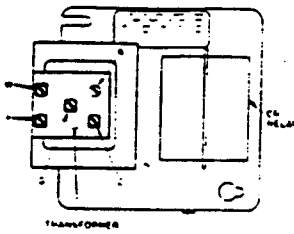

**TRANSFORMER
FIGURE 1**

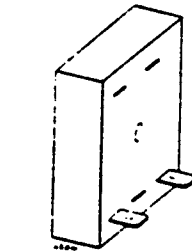

**PRE-PURGE TIMER
FIGURE 5**

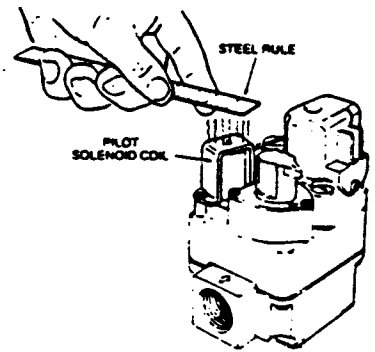

**CHECKING FOR ENERGIZED PILOT
SOLENOID COIL. MAGNETIC PULL
MEANS COIL IS "ON".
FIGURE 9**

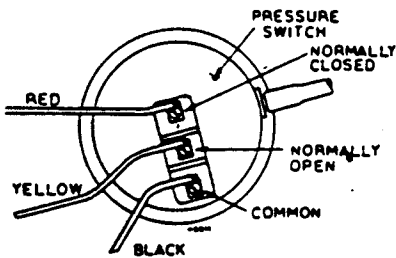

**PRESSURE SWITCH
FIGURE 2**

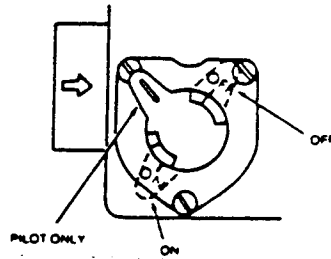

NOTE: When gas cock is positioned over black line on collar around knob, pilot will cycle on and off but main burner gas will not flow.

**36C84 GAS COCK KNOB
FIGURE 6**

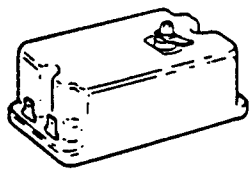

**5059 RELITE CONTROL
FIGURE 3**

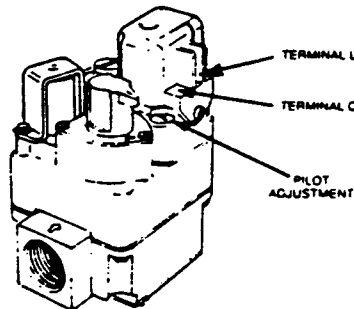

**36C84 GAS VALVE
FIGURE 7**

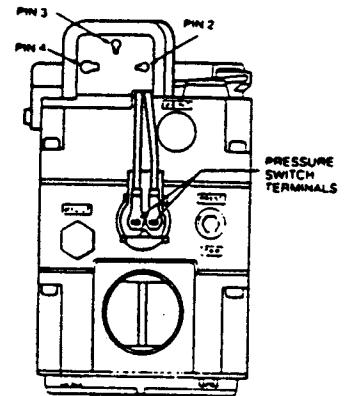

**FLAME SENSOR SOCKET
FIGURE 10**

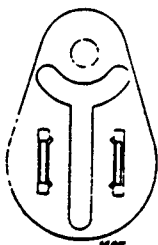

**THERMAL FUSE ELEMENT (TFE)
FIGURE 4**

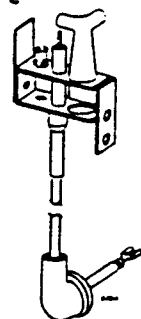

**E50 PILOT BURNER ASSY.
FIGURE 8**

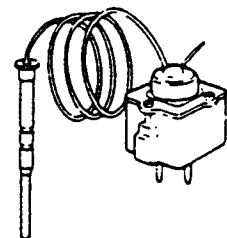

**3098 MERCURY FLAME SENSOR
FIGURE 11**

Operation, Wiring Diagrams, Trouble Shooting

HE (Series 2) and VHE (Series 2) With White-Rodgers Cycle-Pilot® For Natural Gas Firing

BOILER EQUIPMENT COMPONENTS

BLOWER MOTOR

120/60/1, 3450 RPM permanent split capacitor motor with capacitor start and internal overload protection provides rotation of induced draft fan.

FAN (BLOWER WHEEL)

Develops induced draft to supply combustion air to boiler.

PRE-PURGE TIMER

Provides 30 second pre-purge prior to pilot ignition.

HIGH TEMPERATURE LIMIT CONTROL

In the event of high boiler water temperature, shuts down fan and burners but allows circulator to run as long as there is a call for heat from thermostat.

PRESSURE SWITCH

Detects pressure differential across fixed metering orifice to prove air flow through boiler.

COMBINATION PRESSURE AND TEMPERATURE GAUGE

Provides readings of boiler water pressure and temperature.

COMBINATION RELAY RECEPTACLE, JUNCTION BOX AND TRANSFORMER

120/24 VOLT 40 VA transformer provides low voltage for control circuit. Relay receptacle for plug-in circulator relay. Terminal strip for control circuit wiring.

PLUG-IN CIRCULATOR RELAY

Provides contact to energize circulator and fan and contact to prove operation of pressure switch.

ASME SAFETY PRESSURE RELIEF VALVE

Provides safety discharge in the event boiler water pressure exceeds 30 PSIG.

FILL-TROL SYSTEM (TYPES P-HE AND P-VHE ONLY)

Includes compression tank with permanent air cushion and combination manual shut-off valve, check valve, pressure reducing valve and strainer for automatic filling and maintaining minimum system pressure.

AUTOMATIC AIR VENT (TYPES P-HE AND P-VHE ONLY)

Vents air from boiler built-in air eliminator tapping.

GAS VALVE

Incorporates a pilot/redundant solenoid valve, integral pressure switch to sense incoming gas pressure, pressure regulator, main valve operator and socket to accept plug-in Mercury Flame Sensor.

MERCURY FLAME SENSOR

Consists of sensing bulb, capillary tube and diaphragm filled with mercury and connected to SPDT switch. Heat from pilot vaporizes mercury causing diaphragm to snap switch.

RELITE CONTROL

Provides spark to light pilot.

PILOT BURNER ASSEMBLY

Includes spark ignition pilot with mercury flame sensing probe.

THERMAL FUSE ELEMENT (TFE)

Provides safety shutdown of burners and pilot if flame is not contained in firebox.

DRAIN VALVE

Used to drain boiler if necessary.

CIRCULATOR

Provides forced water circulation to hot water heating system.

SEQUENCE OF OPERATION

Referring to Ladder Diagram, Page 5.

1. Thermostat closes, activating relay CR (through pressure switch). Contacts CR1 and CR2 close:
 - a) CR2 activates circulator.
 - b) Blower is activated through limit switch.
 - c) CR1 provides a bypass around pressure switch to prove its operation.
2. When adequate draft is proven by pressure switch, the 30 second pre-purge timer starts.
3. After a 30 second delay, 24 VAC is provided to terminals:
 - a) T2 on relite control which starts spark.
 - b) L on gas valve which opens pilot valve.
4. Pilot ignites:
 - a) Flame conduction stops spark from relite.
 - b) Mercury flame sensor opens main gas valve and pressure switch in gas valve holds pilot open.
5. After thermostat is satisfied, CR is deactivated:
 - a) CR2 opens turning off blower and pump.
 - b) CR1 opens turning off gas flow.
6. As air flow from blower reduces pressure, switch changes to normally closed position.
7. Boiler is now in "off" cycle.

SCHEMATIC WIRING DIAGRAM

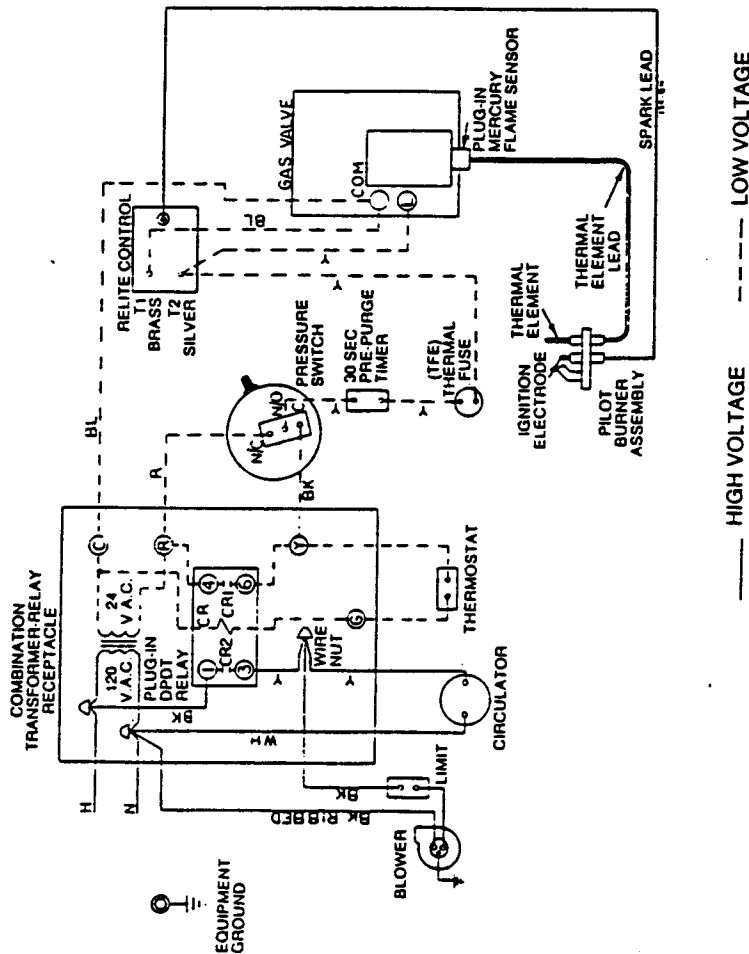

CAUTION

DISCONNECT POWER SOURCE BEFORE INSTALLING AND/OR SERVICING UNIT.

NOTES:

1. All wiring must be installed in accordance with the requirements of the National Electrical Code and any additional national, state, or local code requirements having jurisdiction.
2. All safety circuit wiring must be N.E.C. Class 1.
3. Refer to Control Components Instructions Sheets packed with the boiler for application information.
4. Use only 90° C. Thermoplastic Wire, or equivalent, if any of the original wire must be replaced.

THERMOSTAT HEAT ANTICIPATOR SETTING	
SYSTEM	HE and VHE
WATER	0.40 AMPS.

LADDER WIRING DIAGRAM

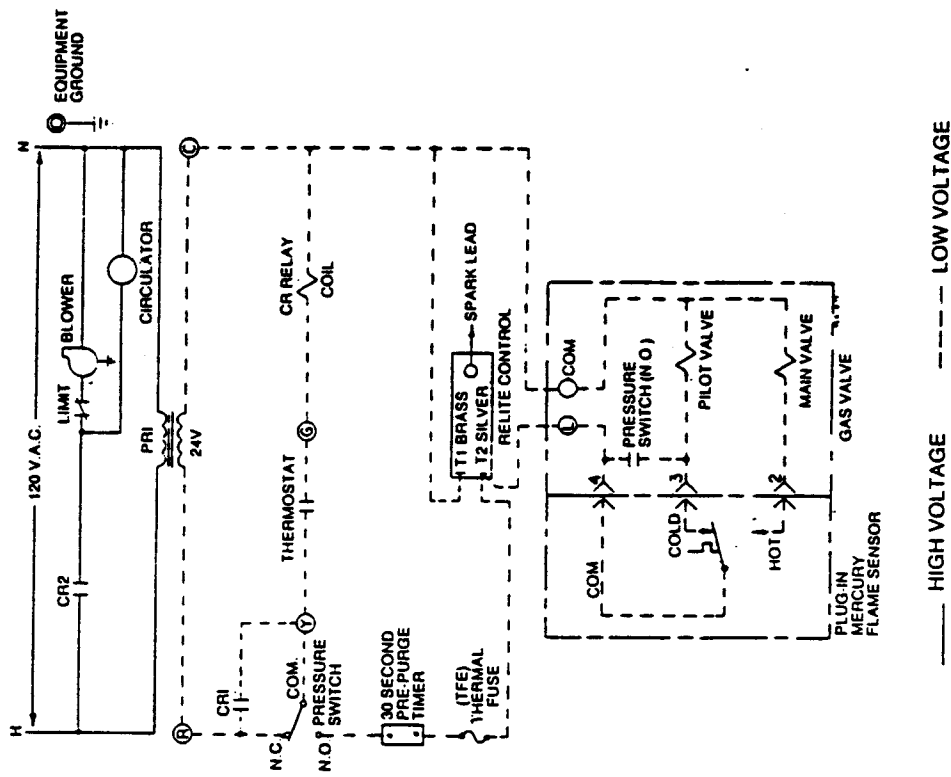

— HIGH VOLTAGE

--- LOW VOLTAGE

WEIL-McLAIN
Michigan City, Indiana 46360
A Marley Company

HE Series 2 and VHE Series 2—White-Rodgers Cycle-Pilot®—Boiler Schematic and Ladder Diagrams. Applicable for forced hot water boilers.

TROUBLE SHOOTING PROCEDURE

DANGER

NEVER jumper out (by-pass) the Thermal Fuse Element (TFE) or any other safety device (except for momentary testing as outlined in Trouble Shooting Tables). A fire causing property damage and/or personal injury could result.

- A. Before starting the trouble shooting procedure, be sure of the following:
1. You have a voltmeter capable of checking 120 VAC, 24 VAC and a continuity tester.
 2. That 120 VAC power supply is available to the boiler (minimum 102 VAC, maximum 132 VAC).
 3. That there is 24 VAC at the secondary side of the control transformer.
 4. You have an inclined manometer with a range of 0-2.0" W.C.

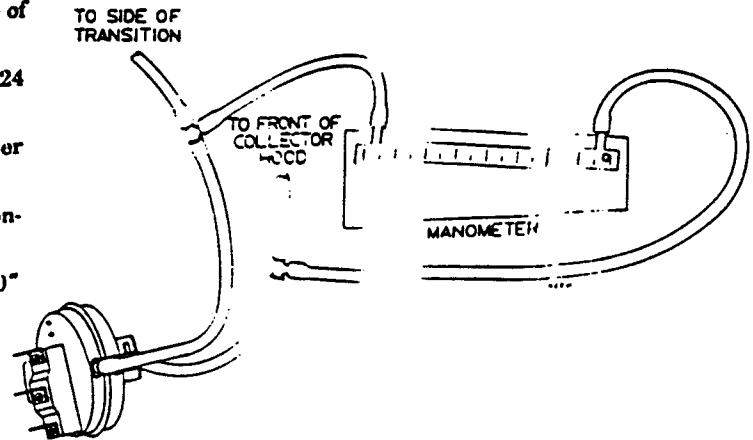

FIGURE 12

CHECKING THE PRESSURE DIFFERENTIAL SWITCH

Note: Make sure boiler water temperature is 100°F or cooler before beginning procedure.

1. Remove the sensing tube at the front of the pressure switch (closest to you as you face the boiler). Refer to Figure 12.
2. Install a "T" into the sensing tube and another piece of tubing from the "T" to the pressure switch.
3. Attach the third leg of the "T" to the suction side of an inclined manometer.
4. Remove the sensing tube at the rear of the pressure switch.
5. Install a "T" into the sensing tube and another piece of tubing from the "T" to the pressure side of the manometer.
6. Attach the third leg of the "T" to the pressure side of the manometer.
7. Close the manual main gas valve and set thermostat to call for heat. Blower will run but pilot and main burners will not ignite.
8. Check for 24 VAC between normally open terminal on pressure switch and terminal C on transformer (Figure 1 and 2).
9. If the reading on the manometer is at least 1.8 inches water column pressure, but there is not 24 V across N.O. terminal on pressure switch and terminal C, replace the pressure switch.
10. If the reading is lower than 1.8" W.C. look for the following causes:
 - a. Blockage in sensing tube.
 - b. Obstruction in the blower housing outlet.
 - c. Loose blower wheel on motor shaft.
 - d. Blower motor not at proper RPM.
 - e. Blower back plate not sealed properly.
 - f. Blockage in the block assembly.
 - g. Blockage in the flue pipe or termination.
11. When pressure reading is proper and pressure switch is operating properly, remove "T"'s and re-install sensing tubes to the pressure switch.

TABLE I—BLOWER AND CIRCULATOR WILL NOT OPERATE

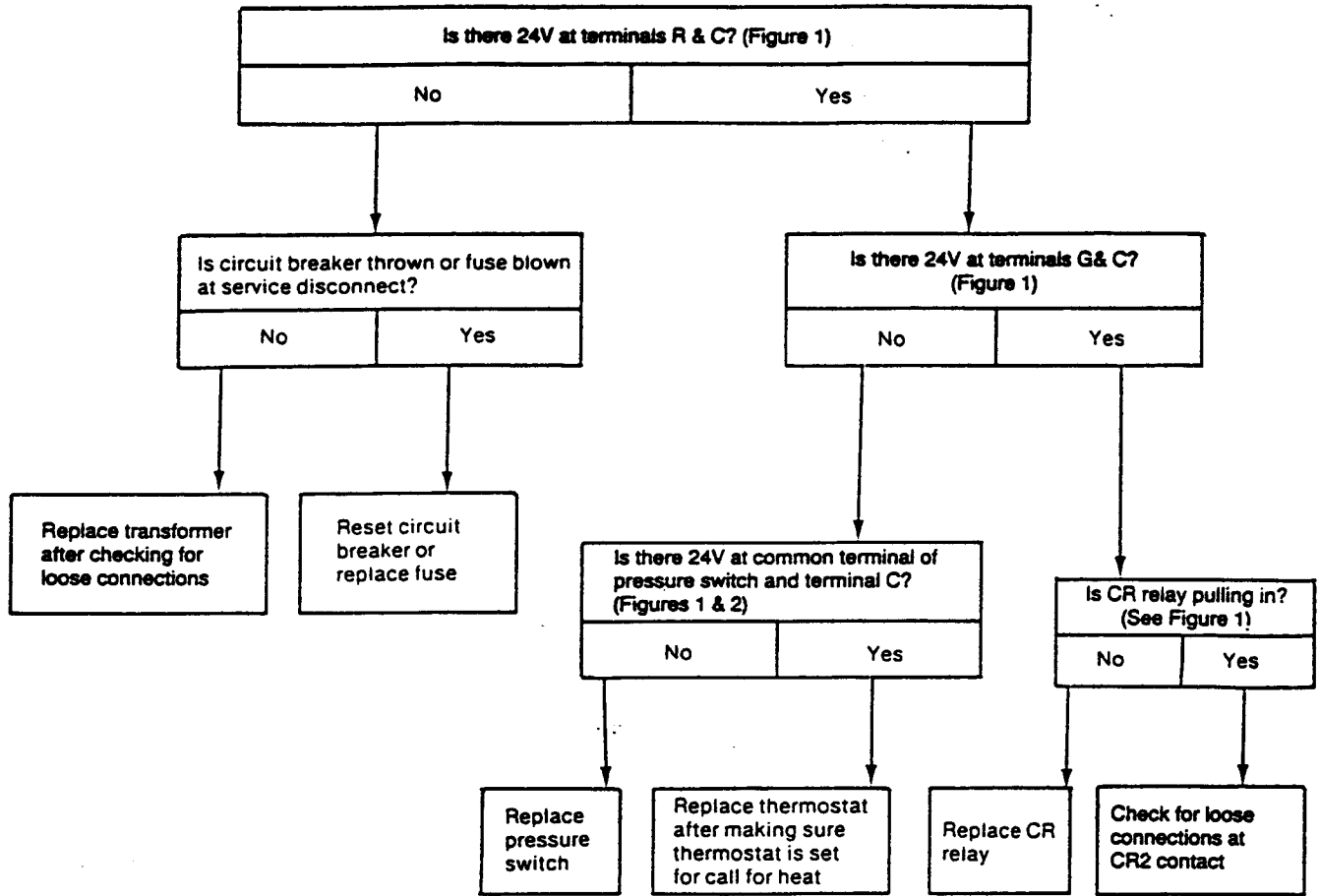

TABLE II—BLOWER WILL NOT OPERATE, BUT CIRCULATOR DOES OPERATE

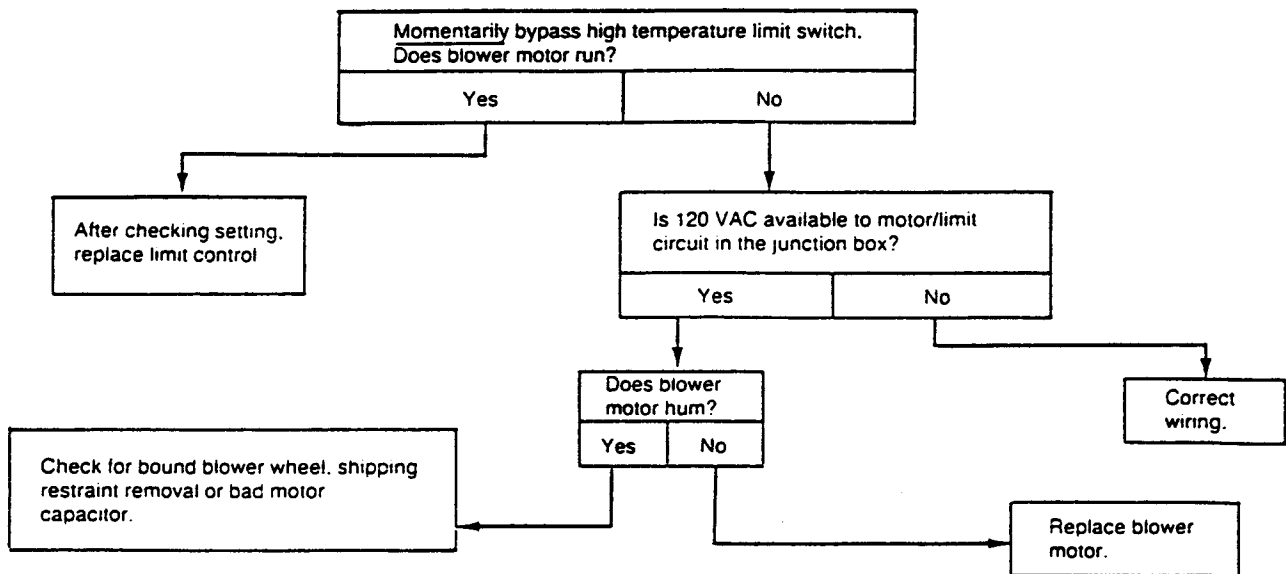

TABLE III—CIRCULATOR WILL NOT OPERATE, BUT BLOWER DOES OPERATE

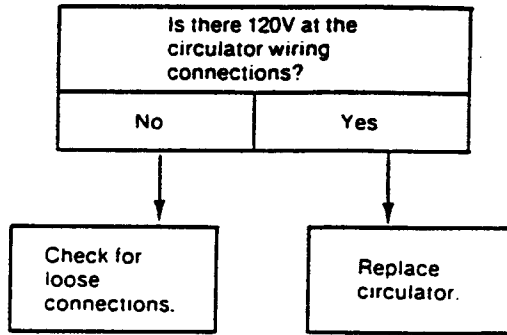

TABLE IV—NO SPARK AT PILOT—BLOWER & CIRCULATOR BOTH OPERATE

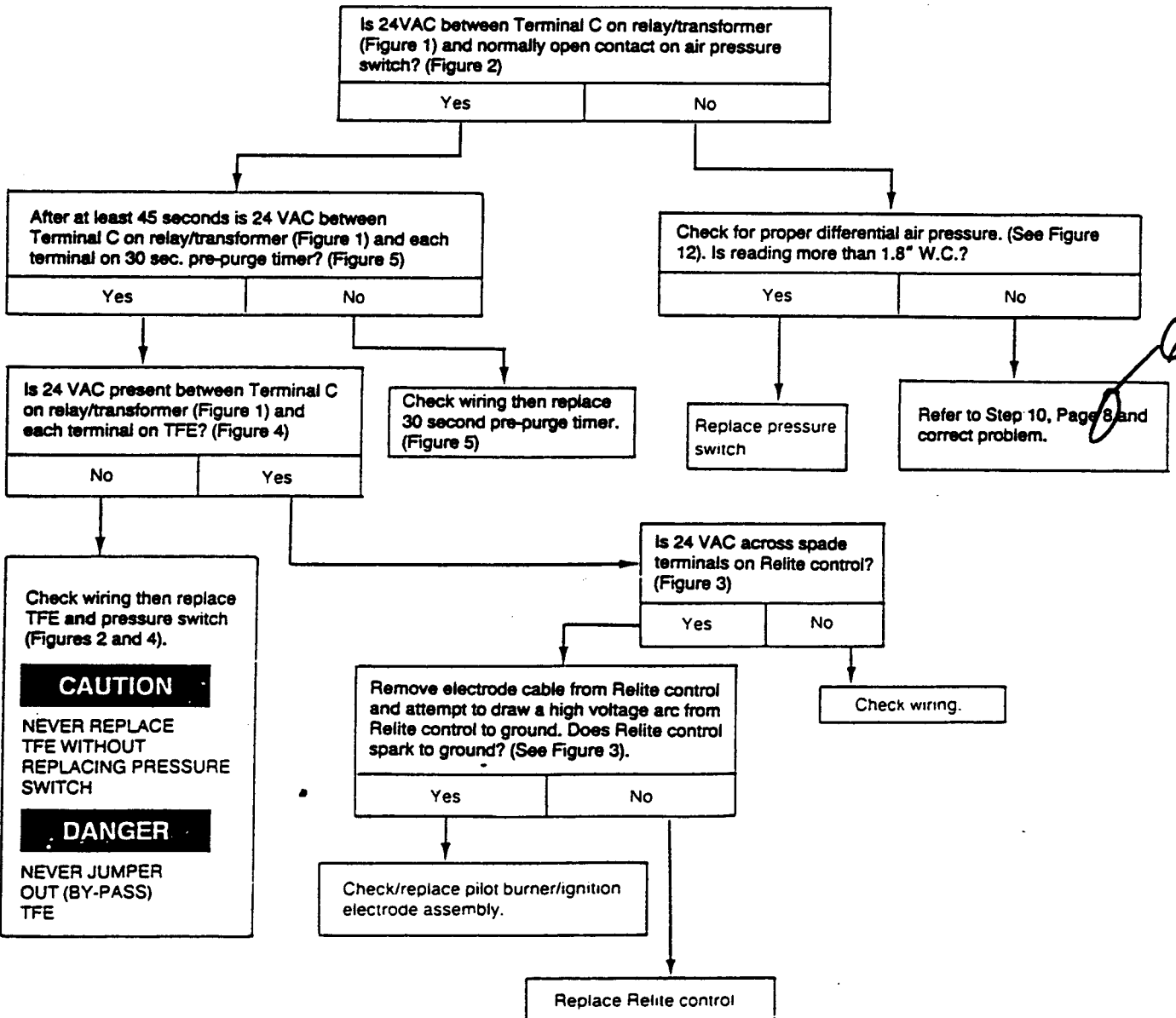

TABLE V—SPARK IS PRESENT—PILOT WILL NOT LIGHT

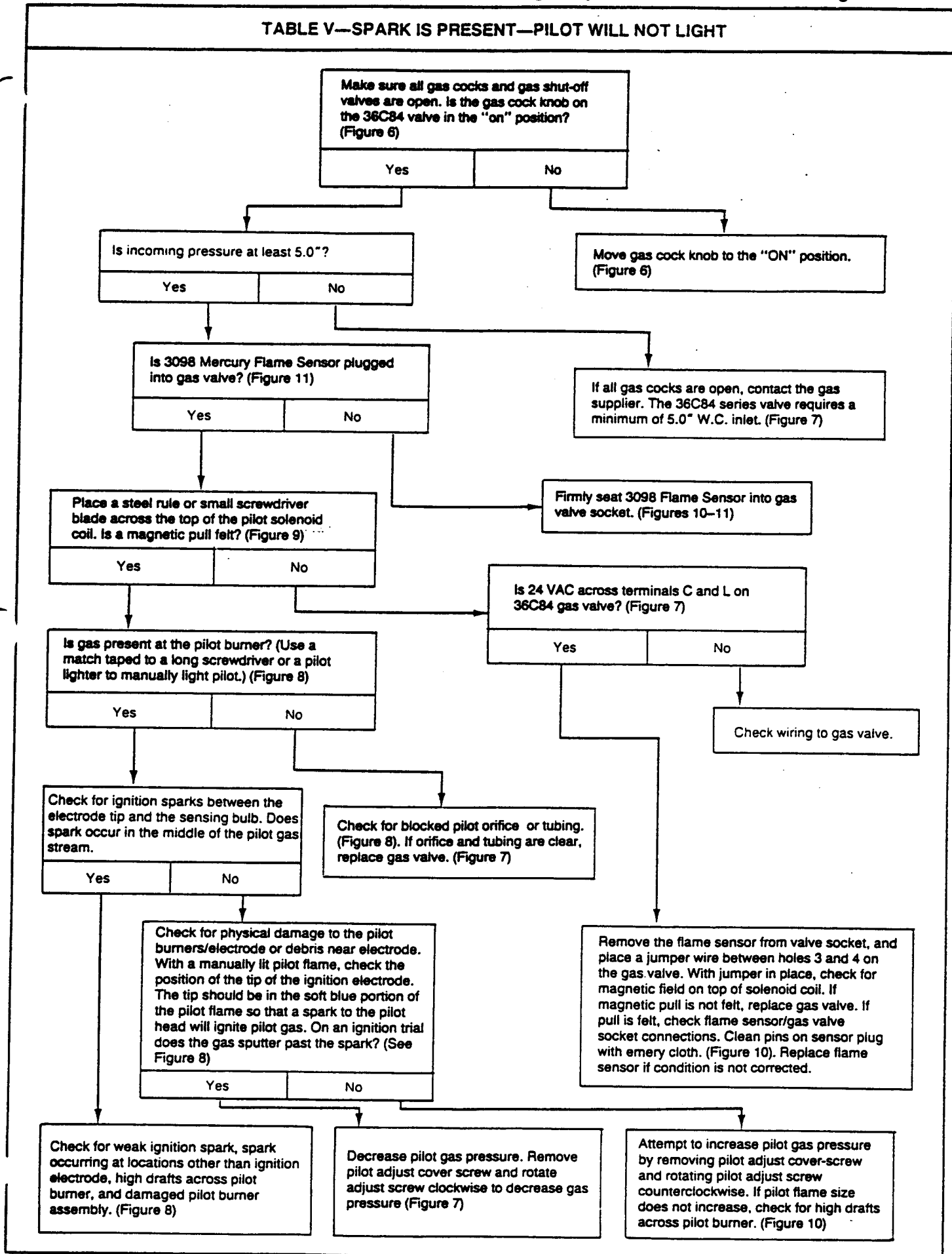

TABLE VI—SPARK WILL NOT SHUT-OFF AFTER PILOT FLAME IS ESTABLISHED

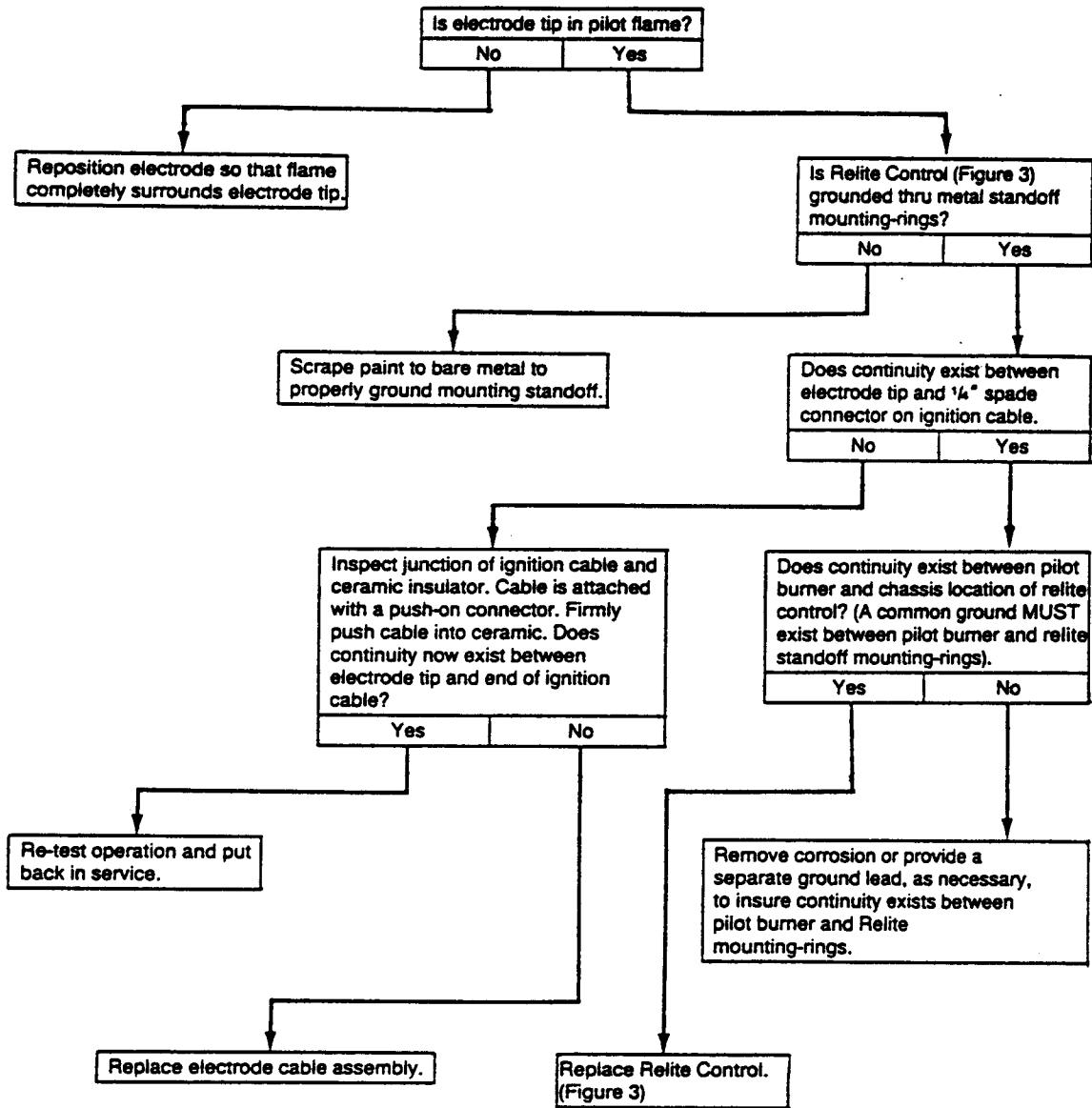
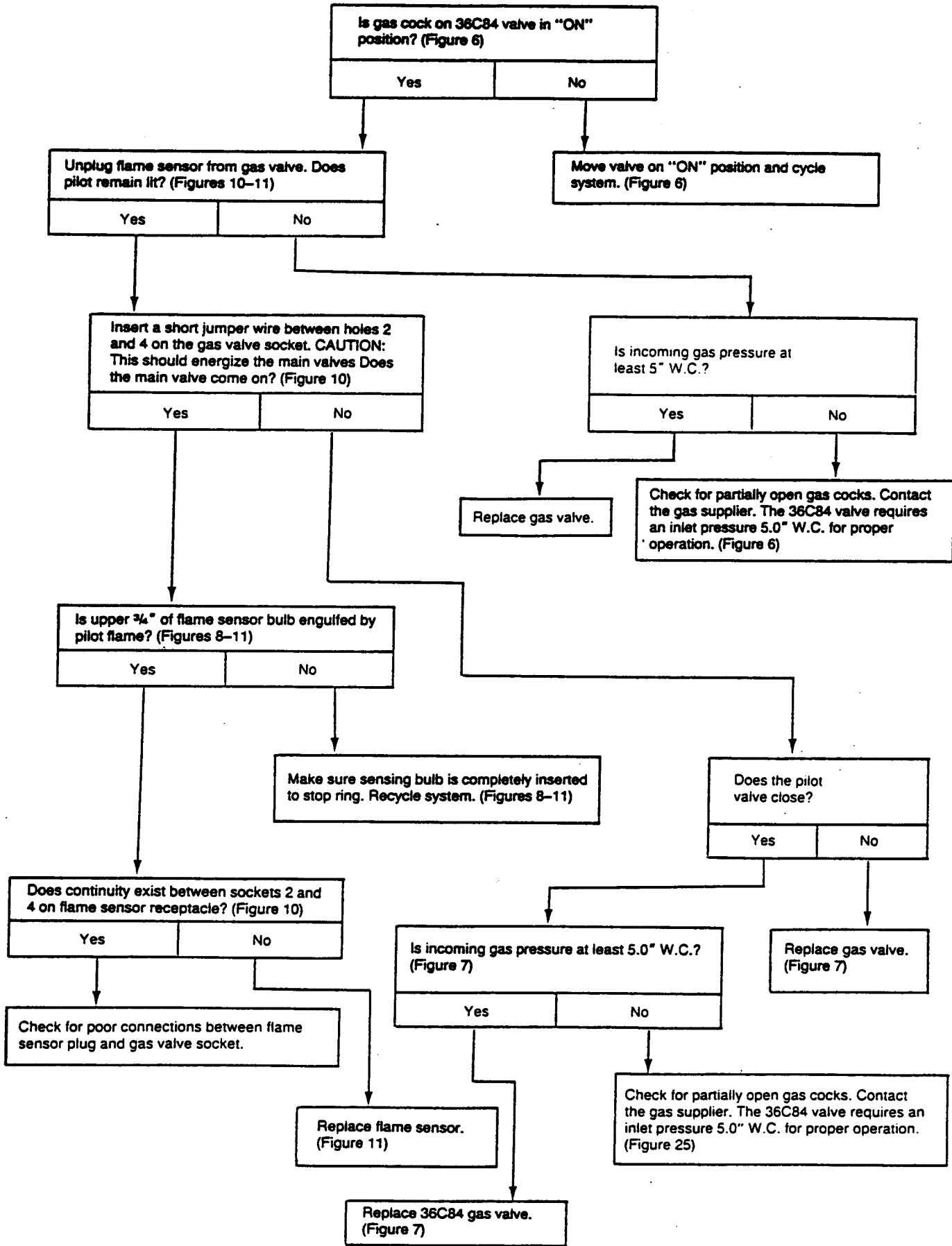

TABLE VII—PILOT LIGHTS—NO MAIN BURNER IGNITION



Free Manuals Download Website

<http://myh66.com>

<http://usermanuals.us>

<http://www.somanuals.com>

<http://www.4manuals.cc>

<http://www.manual-lib.com>

<http://www.404manual.com>

<http://www.luxmanual.com>

<http://aubethermostatmanual.com>

Golf course search by state

<http://golfingnear.com>

Email search by domain

<http://emailbydomain.com>

Auto manuals search

<http://auto.somanuals.com>

TV manuals search

<http://tv.somanuals.com>