

# WESLO® *eclipse*

**LOW IMPACT ELLIPTICAL EXERCISER**

Model No. WLEL36070

Serial No. \_\_\_\_\_

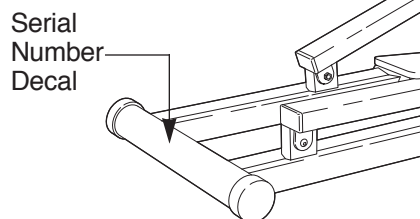

## QUESTIONS?

As a manufacturer, we are committed to providing complete customer satisfaction. If you have questions, or if there are missing or damaged parts, we will guarantee complete satisfaction through direct assistance from our factory.

**TO AVOID DELAYS, PLEASE CALL DIRECT TO OUR TOLL-FREE CUSTOMER HOT LINE.** The trained technicians on our customer hot line will provide immediate assistance, free of charge.

**CUSTOMER HOT LINE:**

**1-800-999-3756**

Mon.-Fri., 6 a.m.-6 p.m. MST

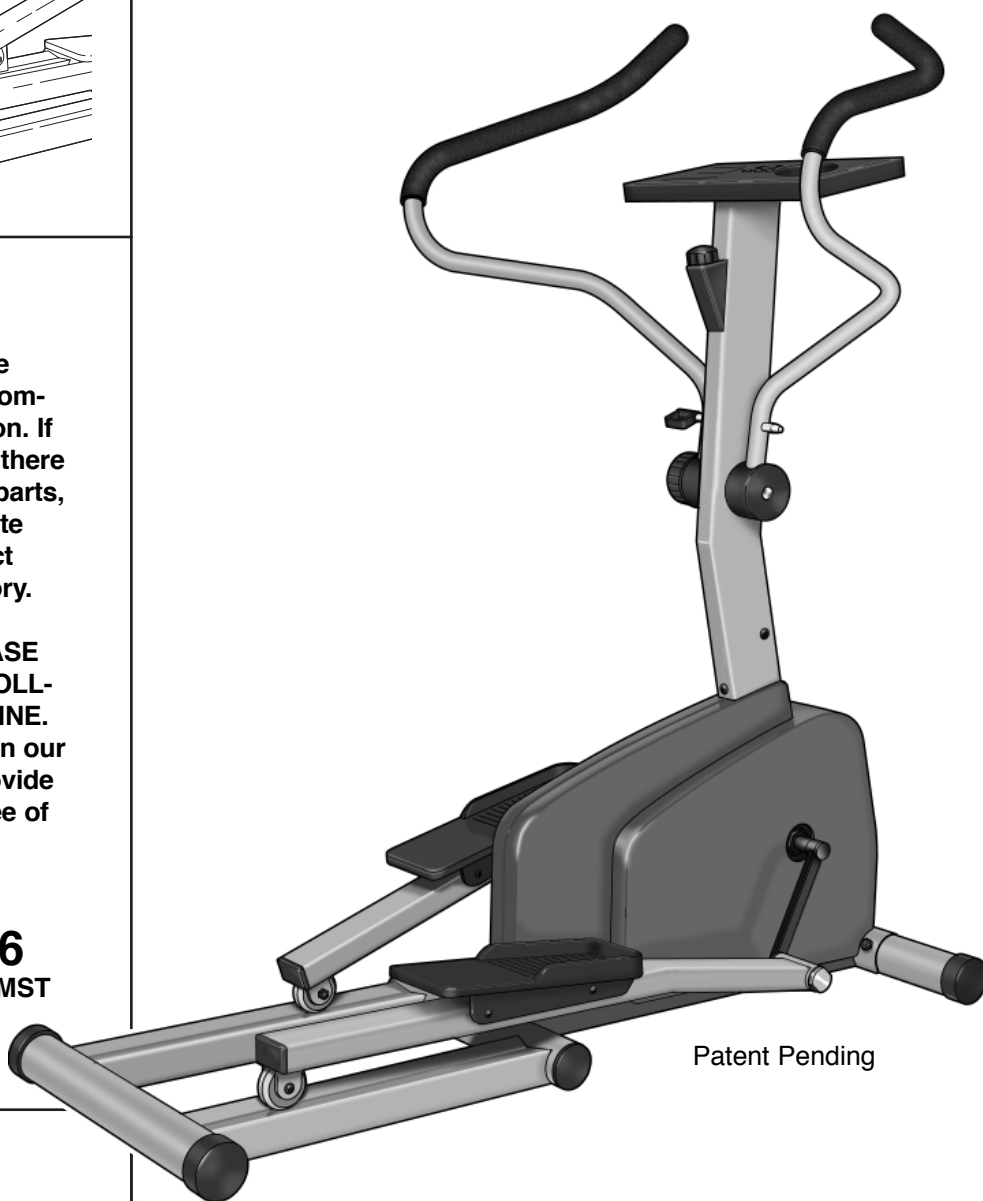

Patent Pending

## CAUTION

Read all precautions and instructions in this manual before using this equipment. Keep this manual for future reference.

# USER'S MANUAL

**WESLO®** *eclipse*  
**LOW IMPACT ELLIPTICAL EXERCISER**

---

## **TABLE OF CONTENTS**

IMPORTANT PRECAUTIONS .....	3
BEFORE YOU BEGIN .....	4
PART IDENTIFICATION CHART .....	5
ASSEMBLY .....	6
MAINTENANCE .....	8
HOW TO USE THE WESLO® ECLIPSE .....	10
CONDITIONING GUIDELINES .....	13
PART LIST .....	14
EXPLODED DRAWING .....	15
HOW TO ORDER REPLACEMENT PARTS .....	.Back Cover
LIMITED WARRANTY .....	.Back Cover

# IMPORTANT PRECAUTIONS

**WARNING:** To reduce the risk of serious injury, read the following important precautions before using the elliptical exerciser.

1. Read all instructions in this manual before using the elliptical exerciser. Use the elliptical exerciser only as described.
2. It is the responsibility of the owner to ensure that all users of the elliptical exerciser are adequately informed of all precautions.
3. Place the elliptical exerciser on a level surface, with a mat beneath it to protect the floor or carpet. Keep the elliptical exerciser indoors, away from moisture and dust.
4. Inspect and tighten all parts regularly. Replace any worn parts immediately.
5. Keep children under the age of 12 and pets away from the elliptical exerciser at all times.
6. Wear appropriate clothing when exercising on the elliptical exerciser. Always wear athletic shoes for foot protection.
7. The elliptical exerciser should not be used by persons weighing more than 250 pounds.
8. Always pin the handlebars in the stationary position and hold the handlebars when mounting and dismounting the elliptical exerciser. Always step onto and off the pedal that is in the lowest position.
9. Each time you stop exercising on the elliptical exerciser, allow the pedals to slowly come to a stop.
10. Always keep your back straight when using the elliptical exerciser. Do not arch your back.
11. If you feel pain or dizziness at any time while exercising, stop immediately and begin cooling down.
12. The elliptical exerciser is intended for in-home use only. Do not use the elliptical exerciser in any commercial, rental, or institutional setting.

**WARNING:** Before beginning this or any exercise program, consult your physician. This is especially important for persons over the age of 35 or persons with pre-existing health problems. Read all instructions before using. ICON assumes no responsibility for personal injury or property damage sustained by or through the use of this product.

The decal shown at the right has been placed on the elliptical exerciser. If the decal is missing, or if it is not legible, please call our Customer Service Department toll-free at 1-800-999-3756 to order a free replacement decal. Apply the decal in the location shown.

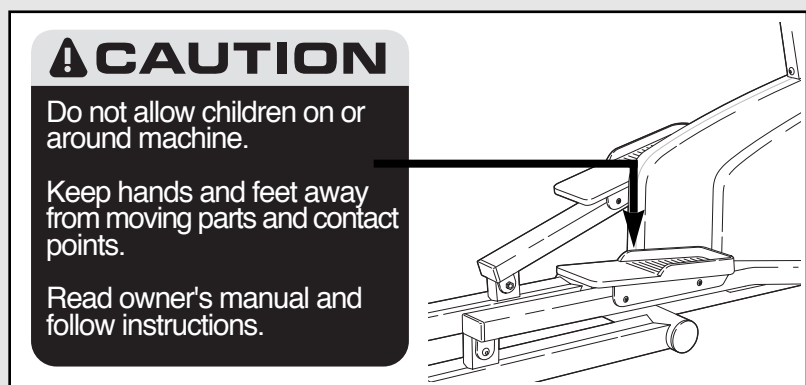

# BEFORE YOU BEGIN

Congratulations for selecting the revolutionary WESLO® ECLIPSE low-impact elliptical exerciser. The ECLIPSE is an incredibly smooth exerciser that moves your feet in a natural elliptical path, minimizing the impact to your knees and ankles. And the unique ECLIPSE features adjustable resistance, dual-motion handlebars, and a multi-mode exercise monitor to help you get the most from your exercise. Welcome to a whole new world of natural, elliptical-motion exercise from WESLO.

**For your benefit, read this manual carefully before you use the WESLO® ECLIPSE.** If you have ques-

tions after reading the manual, call our Customer Service Department toll-free at 1-800-999-3756, Monday through Friday, 6 a.m. until 6 p.m. Mountain Time (excluding holidays). To help us assist you, please note the product model number and serial number before calling. The model number is WLEL36070. The serial number can be found on a decal attached to the ECLIPSE (see the front cover of this manual for the location of the decal).

Before reading further, please look at the drawing below and familiarize yourself with the parts that are labeled.

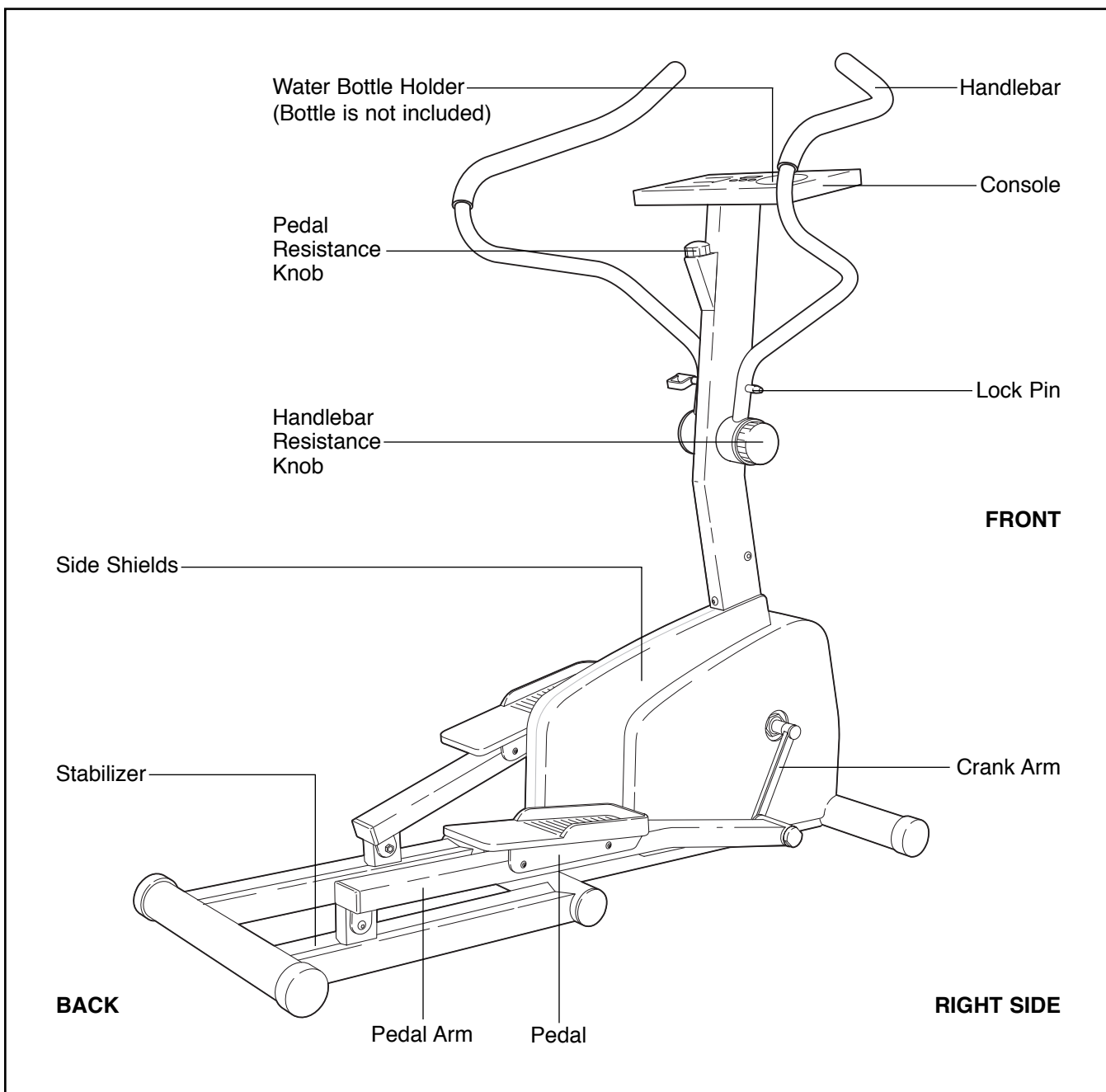

# PART IDENTIFICATION CHART

Use the chart below to identify the small parts used in assembly. The number in parenthesis below each part is the key number of the part, from the PART LIST on page 14. The number after the dash indicates the

quantity needed for assembly. **Note: Some small parts may have been pre-attached for shipping. If a part is not in the parts bag, check to see if it has been pre-attached.**

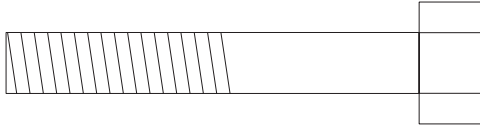
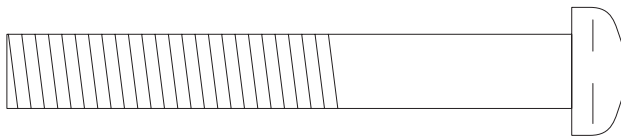
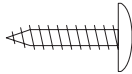
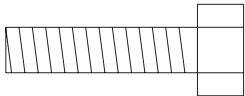
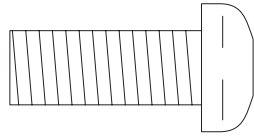
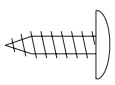
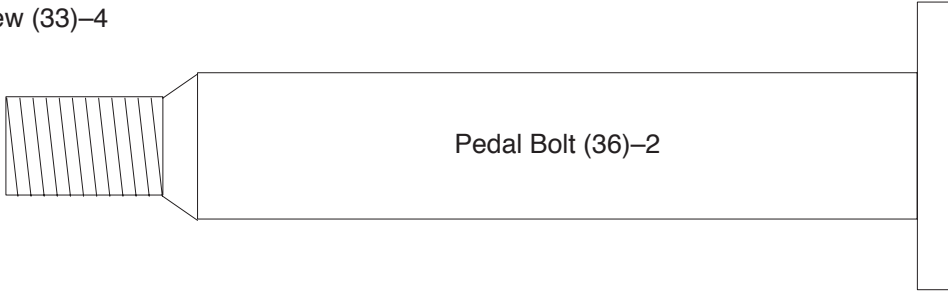
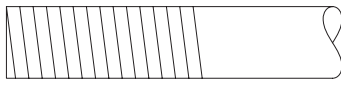
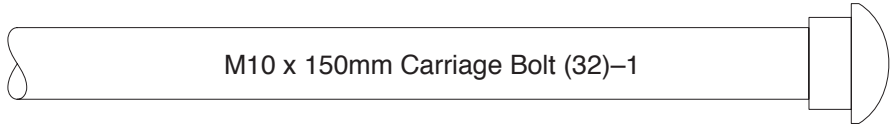
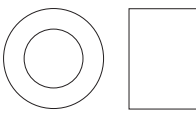
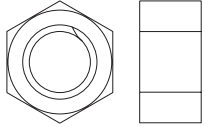
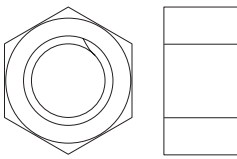
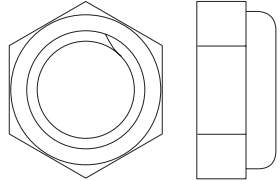
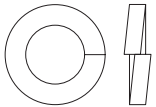
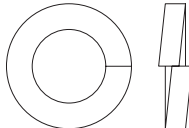
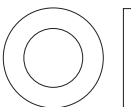
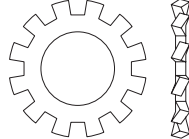
			
M8 x 55mm Hex Head Bolt (63)-2	M10 x 75mm Button Head Bolt (45)-2		
			
M4 x 16mm Screw (51)-6	M6 x 1" Hex Head Screw (27)-2	M10 x 25mm Button Head Screw (25)-3	
			
Console Screw (33)-4	Pedal Bolt (36)-2		
			
	M10 x 150mm Carriage Bolt (32)-1		
			
Wheel Spacer (79)-2	M8 Nylon Locknut (64)-2	M10 Nylon Locknut (46)-2	1/2" Nylon Locknut (37)-2
			
1/4" Split Washer (62)-2	M10 Split Washer (69)-3	M8 Washer (74)-2	Star Washer (29)-1

# ASSEMBLY

Place all parts of the WESLO® ECLIPSE in a cleared area and remove the packing materials. **Do not dispose of the packing materials until assembly is completed.**

In addition to the included allen wrench and flat wrench, a phillips screwdriver  and two adjustable wrenches  are required for assembly.

1. Position the Stabilizer (4) against the saddle on the Frame (1). Insert two M10 x 75mm Button Head Bolts (45) through the Frame and the Stabilizer. Tighten M10 Nylon Locknuts (46) onto the Button Head Bolts.

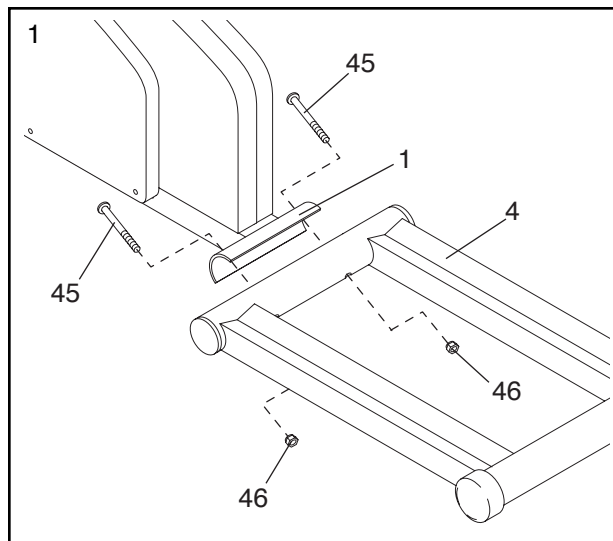

2. Attach a Pedal (9) to the Left Pedal Arm (7) with three M4 x 16mm Screws (51).

If there is not a Wheel (60) on the Left Pedal Arm (7), attach one in the following way: Hold a Wheel Cover (59) inside of the bracket on the Left Pedal Arm (7). Insert an M8 x 55mm Hex Head Bolt (63) with an M8 Washer (74) into one side of the bracket and the Wheel Cover. Slide a Wheel Spacer (79), a Wheel (60), and another Wheel Spacer onto the end of the Bolt. Insert the Bolt through the other side of the Wheel Cover and the bracket. Tighten an M8 Nylon Locknut (64) with an M8 Washer (74) onto the Bolt.

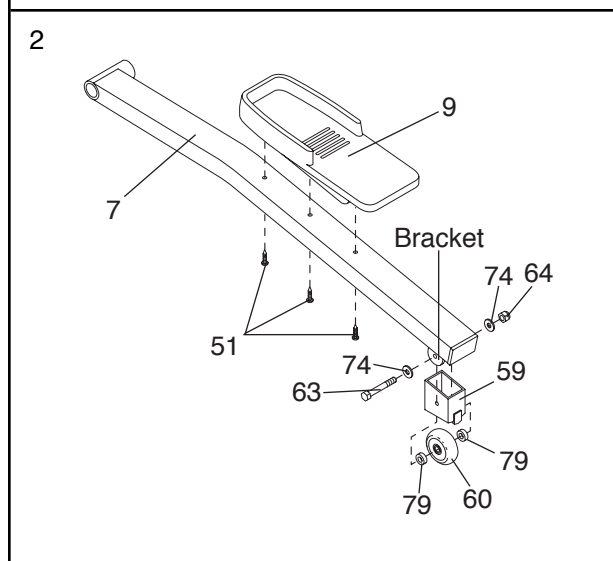

Assemble the Right Pedal Arm (not shown) in the same way.

3. Insert a Pedal Bolt (36) through the bushings in the Left Pedal Arm (7). Using the included flat wrench, tighten the Pedal Bolt into the left arm of the Crank (38). **Next, back the Pedal Bolt out of the Crank a quarter of a turn.** While holding the Pedal Bolt stationary, tighten a 1/2" Nylon Locknut (37) onto it.

Attach the Right Pedal Arm (not shown) in the same way.

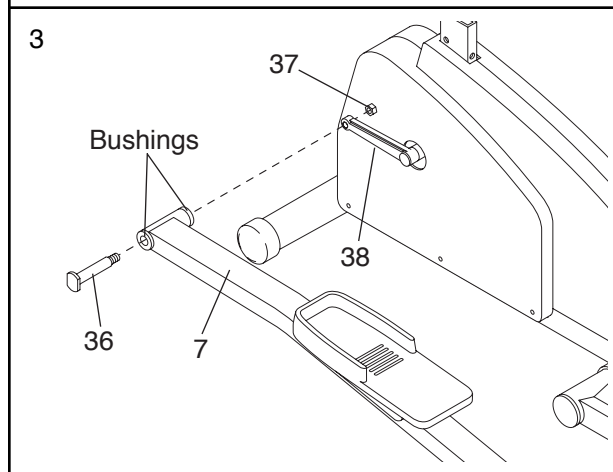

4. Connect the Reed Switch Wire (3) to the Extension Wire (15).

Slide the Upright (2) onto the Frame (1); **be careful not to pinch the Reed Switch Wire (3), the Extension Wire (15), or the Resistance Cable (17).** Attach the Upright with three M10 x 25mm Button Head Screws (25) and three Split Washers (69).

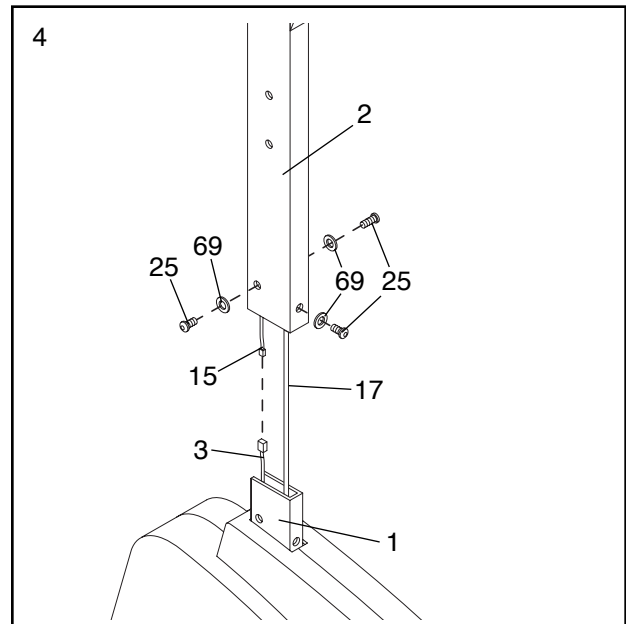

5. Attach the Upright Bracket (26) to the Upright (2) with two M6 x 1" Hex Head Screws (27) and two 1/4" Split Washers (62). The square hole must be on the left side.

Push the Handlebar Caps (28) onto the lower ends of the Handlebars (10, 11). Align the indicated holes and make sure that the frictions pads are on the side shown. See drawing 5a. Apply a thin film of grease to both sides of the Handlebar Caps.

Hold the lower end of the Left Handlebar (10) inside of the Upright Bracket (26). Insert the M10 x 150mm Carriage Bolt (32) into the Upright Bracket and through the Left Handlebar. **Be careful not to damage the wires inside the Upright.** Hold the Right Handlebar (11) inside of the Upright Bracket. Insert the Carriage Bolt until the head of the Carriage Bolt is in the square hole in the Upright Bracket. Slide the Star Washer (29) onto the Carriage Bolt and tighten the Resistance Knob (30) onto the Carriage Bolt.

See drawing 5b. Align the holes in the Handlebars (10, 11) with the hole in the Upright (2). Insert the Lock Pin (31) through the Handlebars and the Upright. **Be careful not to damage the wires inside the Upright.**

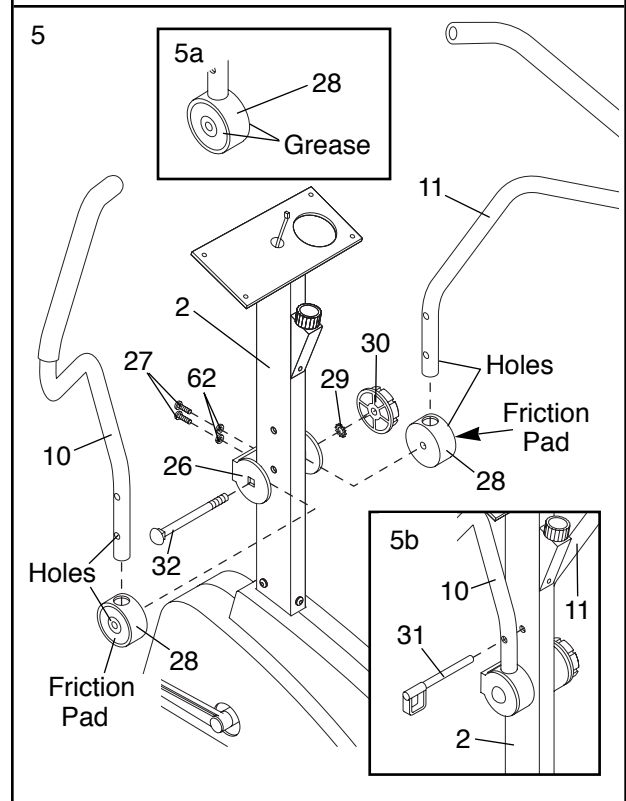

6. Connect the console wire to the Extension Wire (15). Insert the Extension Wire and the console wire into the Upright (2). Attach the Console to the Upright with four Console Screws (33).

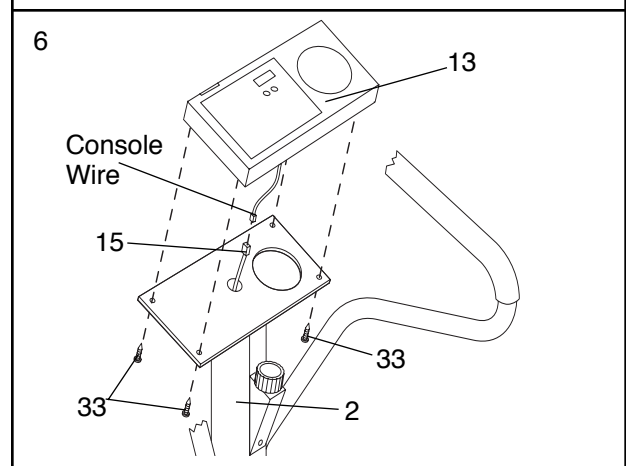

7. The Console (13) requires two "AA" batteries (not included). Alkaline batteries are recommended.

To install batteries, first slide up the Battery Cover (14). Carefully remove the battery clip from the Console (13). Insert two batteries into the battery clip. **Make sure that the negative ends of the batteries (marked "-") are touching the springs.** Replace the battery clip and close the Battery Cover.

8. **Make sure that all parts of the ECLIPSE are properly tightened.** Place a mat under the ECLIPSE to protect the floor or carpet from damage.

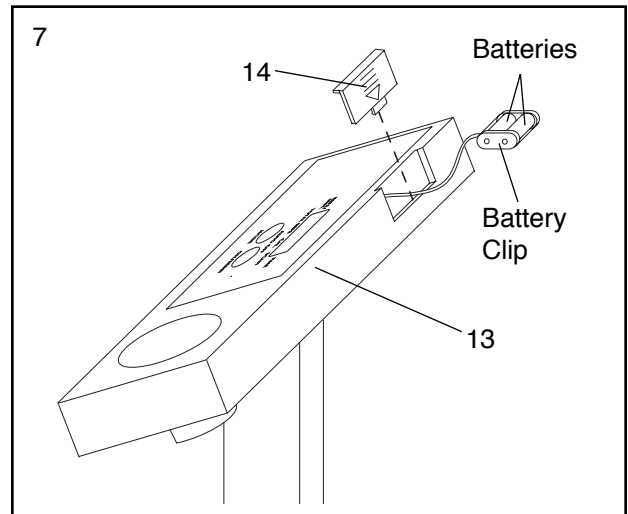

## MAINTENANCE

Inspect and tighten all parts of the ECLIPSE regularly. Replace any worn parts immediately.

For continued smooth operation of the ECLIPSE, the Stabilizer (4) should be kept clean. Using a soft cloth and mild detergent, clean any dust and residue that may build up where the Wheels (60) move on the Stabilizer. Other components of the ECLIPSE can also be cleaned in this manner.

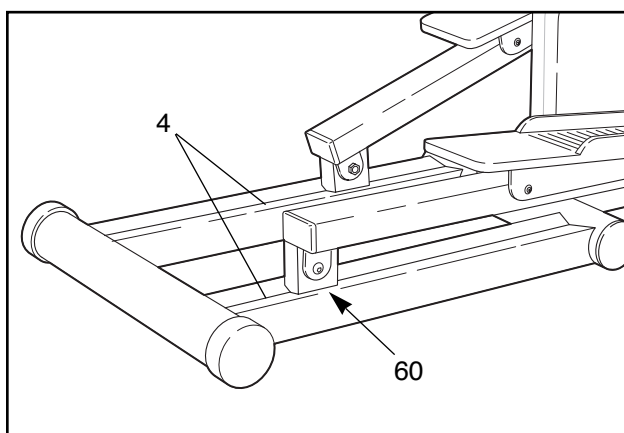

**IMPORTANT: Never use abrasives or solvents to clean the ECLIPSE. To prevent damage to the console, keep liquids away from the console and keep the console out of direct sunlight.**

## LUBRICATING THE HANDLEBARS

If a squeaking sound is heard when the Handlebars (10, 11) are moved, a small amount of grease should be applied. Refer to the drawing below. Turn the Resistance Knob (30) counterclockwise and remove it. Remove the Star Washer (29). Using pliers, grip the head of the Carriage Bolt (32) and remove it. Apply a thin film of grease to both sides of the Handlebar Caps (28). Reattach all parts, making sure that they are in the positions shown.

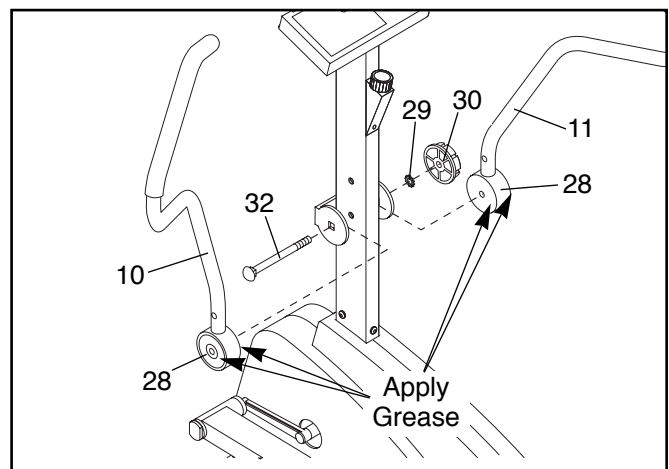



## ELECTRONIC MONITOR TROUBLE-SHOOTING

If the console does not function properly, the batteries should be replaced. To replace the batteries, see assembly step 7 on page 8. In addition, make sure that the console wire is connected to the extension wire. See assembly step 6 on page 7.

## HOW TO ADJUST THE REED SWITCH

If the console does not display correct feedback, the reed switch should be adjusted. In order to adjust the reed switch, the Left Side Shield (5) must be removed. Remove the 1/2" Nylon Locknut (37) from the Pedal Bolt (36). Turn the Pedal Bolt and remove it from the Crank (38); do not remove the Pedal Bolt from the Left Pedal Arm (7). Set the Left Pedal Arm aside.

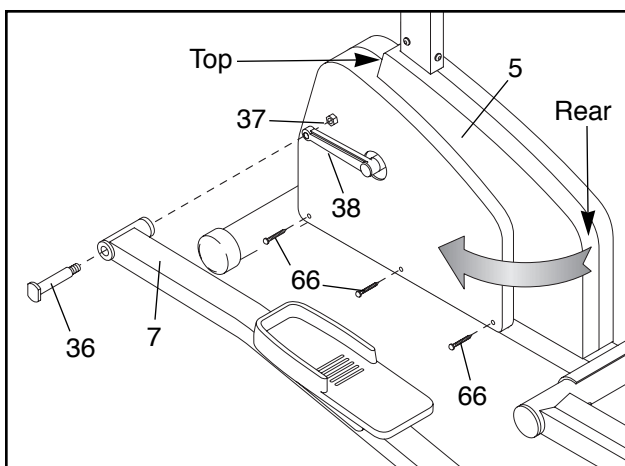

Remove the three M4 x 38mm Screws (66) from the bottom of the Left Side Shield (5). Grasp both Side Shields at the top and gently pull them apart. Make sure that the arm of the Crank (38) is in the position shown in the drawing above. Hold the Left Side Shield at the rear and pull it gently away from the frame. Work the Left Side Shield forward off the arm of the Crank and remove it.

Next, locate the Reed Switch (3). Loosen, but do not remove, the M4 x 16mm Screw (51). Slide the Reed Switch slightly toward or away from the magnet on the pulley. Retighten the Screw. Turn the Crank (38) for a moment. Repeat until the console displays correct feedback. When the Reed Switch is correctly adjusted, reattach the left side shield.

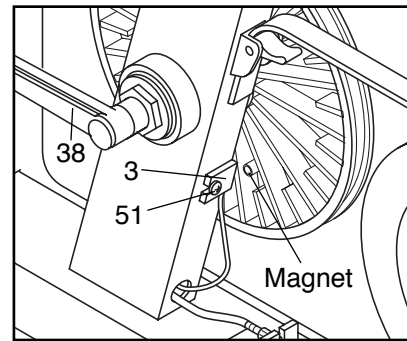

## HOW TO ADJUST THE TENSION BELT

If the pedals do not have enough resistance, even when the pedal resistance knob is turned to the maximum setting, the Resistance Belt (24) may need to be adjusted. To adjust the Resistance Belt, the left side shield must be removed. Refer to the instructions at the left to remove the left side shield.

Next, turn the pedal resistance knob to its lowest setting. Locate and open the latch on the Resistance Belt Clamp (49). Grip the end of the Resistance Belt (24) and pull it down to remove any slack. While holding the end of the Tension Belt, close the latch on the Tension Belt Clamp. Turn the Crank (38) for a moment to make sure that there is not too much resistance. When the resistance strap is properly adjusted, reattach the left side shield.

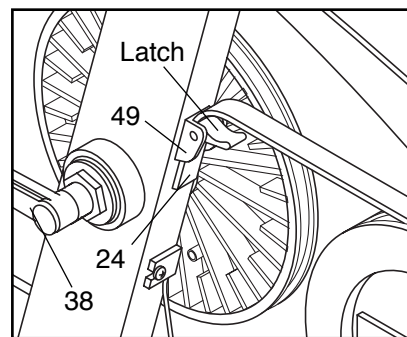

# HOW TO USE THE WESLO® ECLIPSE

## HOW TO EXERCISE ON THE ECLIPSE

To mount the ECLIPSE, pin the handlebars in the stationary position, hold the handlebars, and step onto the pedal that is in the lowest position. Next, step onto the other pedal. Push the pedals until they begin to move with a continuous motion. **Note: The crank can turn in either direction; it is recommended that you turn the crank in the direction shown below; however, to give variety to your exercise, you may choose to turn the crank in the opposite direction.**

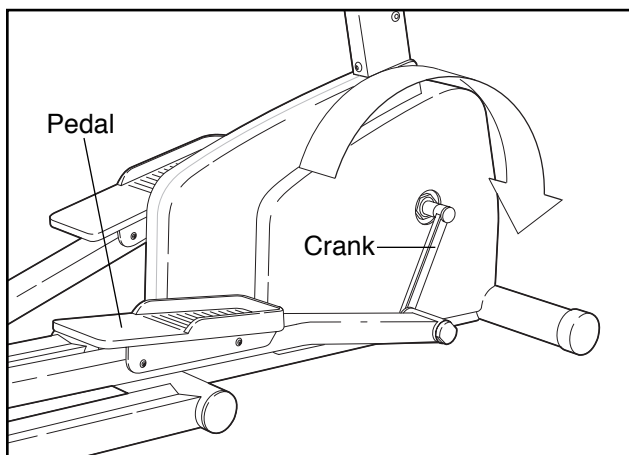

To dismount the ECLIPSE, allow the pedals to slowly come to a stop. **CAUTION: The ECLIPSE does not have a freewheel; the pedals will continue to move until the flywheel stops.** When the pedals are stationary, step off the highest pedal first. Then, step off the lowest pedal.

## HOW TO ADJUST THE RESISTANCE OF THE PEDALS

As you exercise, you can adjust the resistance of the pedals with the resistance knob mounted on the upright. To increase the resistance, turn the knob clockwise; to decrease the resistance, turn the knob counterclockwise.

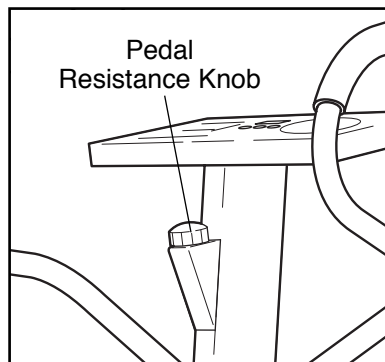

## HOW TO USE THE HANDLEBARS IN THE STATIONARY POSITION

To focus on lower-body exercise, the handlebars can be pinned in a stationary position. To do this, align the holes in the handlebars with the hole in the handlebar post. Next, insert the lock pin through the handlebars and the handlebar post (see the drawing below). **Note: If it is difficult to insert the lock pin, twist the handlebars slightly in order to align the holes; do not twist the handlebars too far or they may be damaged.** Next, tighten the resistance knob.

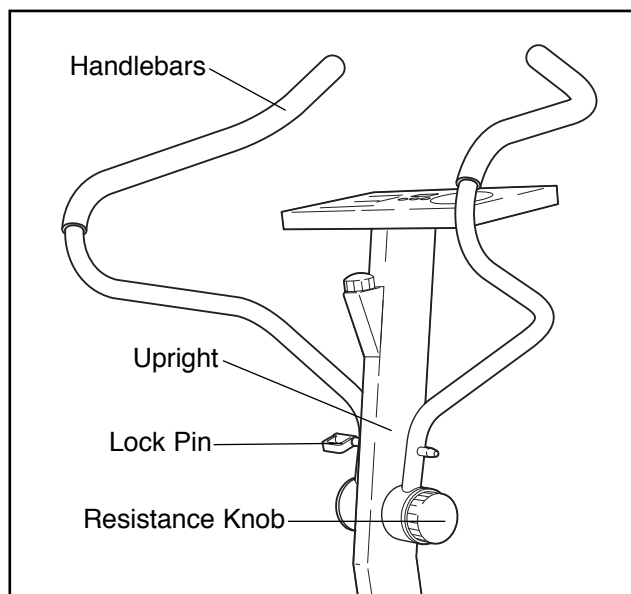

## HOW TO USE THE HANDLEBARS IN THE DUAL-MOTION POSITION

To add upper-body exercise to your workout, remove the lock pin from the handlebars and the handlebar post (see the drawing above). **Keep the lock pin in a safe place.** The resistance of the handlebars can be adjusted with the resistance knob. To increase the resistance, turn the knob clockwise; to decrease the resistance, turn the knob counterclockwise.

To exercise, move the handlebars forward and backward as you pedal. Be sure to keep your back straight and your knees bent slightly.

## DESCRIPTION OF THE CONSOLE

The console features five modes that provide instant exercise feedback during your workouts. The modes are described below.

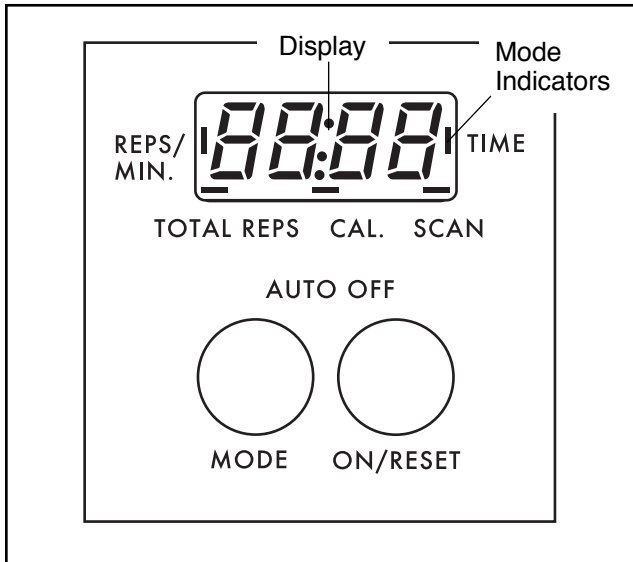

- Reps/Min.—Displays your speed, in repetitions (strides) per minute.
- Time—Displays the length of time you have exercised. Note: If you stop exercising for ten seconds or longer, the time mode will pause until you resume.
- Total Reps—Displays the total number of repetitions (strides) you have completed, up to 999. The display will then reset to zero and continue counting.
- Calorie—Displays the approximate number of Calories you have burned.
- Scan—Displays the reps per minute, time, total reps, and calorie modes, for 5 seconds each, in a repeating cycle.

## BATTERY INSTALLATION

Before the console can be operated, two “AA” batteries must be installed. If you have not installed batteries, see assembly step 7 on page 8.

## HOW TO OPERATE THE CONSOLE

1. To turn on the power, press the on/reset button or simply begin exercising on the ECLIPSE. When the power is turned on, the entire display will appear for two seconds. The console will then be ready for operation.
2. Select one of the five modes:

**Scan mode—**  
When the power is turned on, the scan mode will automatically be selected. One mode indicator will show that the scan mode is selected, and a flashing mode indicator will show which mode is currently displayed. Note: If a different mode is selected, you can select the scan mode again by repeatedly pressing the mode button.

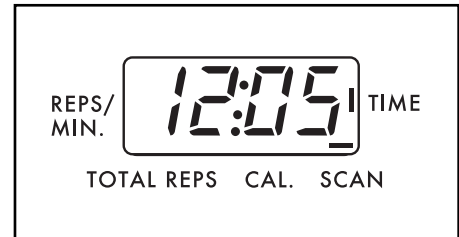

**Reps per minute, time, total reps or calorie, mode—**  
To select one of these modes for continuous display, repeatedly press the mode button. The mode indicators will show which mode is selected. (Make sure that the scan mode is not selected.)



3. To reset the display, press the on/reset button.
4. To turn off the power, simply wait for about four minutes. **Note: The console has an “auto-off” feature. If the pedals are not moved and the console buttons are not pressed for four minutes, the power will turn off automatically in order to conserve the batteries.**

# CONDITIONING GUIDELINES

The following general guidelines will help you to plan your exercise program. Remember that proper nutrition and adequate rest are essential for successful results.

**WARNING: Before beginning this or any exercise program, consult your physician. This is especially important for persons over the age of 35 or persons with pre-existing health problems.**

## EXERCISE INTENSITY

Whether your goal is to burn fat or strengthen your cardiovascular system, the key to achieving the desired results is to exercise with the proper intensity. The proper intensity level can be found by using your heart rate as a guide. The chart below shows recommended heart rates for fat burning, maximum fat burning, and cardiovascular (aerobic) exercise.

BPM		HEART RATE TRAINING ZONES					
♥	165						Aerobic
	145	155					Max Fat Burn
	125	138	145				Fat Burn
		120	130	140			
			115	125	130		
				110	118	125	
					105	110	115
						95	103
♥							90
Age	20	30	40	50	60	70	80

To find the proper heart rate for you, first find your age near the bottom of the chart (ages are rounded off to the nearest ten years). Next, look above your age and find the three numbers in light grey boxes. The three numbers are your "training zone." The lowest number is the recommended heart rate for fat burning; the middle number is the recommended heart rate for maximum fat burning; the highest number is the recommended heart rate for aerobic exercise.

## Fat Burning

To burn fat effectively, you must exercise at a relatively low intensity level for a sustained period of time. During the first few minutes of exercise, your body

uses easily accessible carbohydrate calories for energy. Only after the first few minutes of exercise does your body begin to use stored fat calories for energy. If your goal is to burn fat, adjust your pace or the resistance until your heart rate is near the lowest number in your training zone as you exercise.

For maximum fat burning, adjust your pace or the resistance until your heart rate is near the middle number in your training zone as you exercise.

## Aerobic Exercise

If your goal is to strengthen your cardiovascular system, your exercise must be "aerobic." Aerobic exercise is activity that requires large amounts of oxygen for prolonged periods of time. This increases the demand on the heart to pump blood to the muscles, and on the lungs to oxygenate the blood. For aerobic exercise, adjust your pace or the resistance until your heart rate is near the highest number in your training zone.

## Strength Training

To strengthen and tone your muscles, you must exercise your muscles at a moderate to high percentage of their capacity. To do this, adjust the resistance to a high level.

## HOW TO MEASURE YOUR HEART RATE

To measure your heart rate, first exercise for at least four minutes. Then, stop exercising and place two fingers on your wrist as shown. Take a six-second heartbeat count, and multiply the result by 10 to find your heart rate. For example, if your six-second heartbeat count is 14, your heart rate is 140 beats per minute. (A six-second count is used because your heart rate will drop rapidly when you stop exercising.)

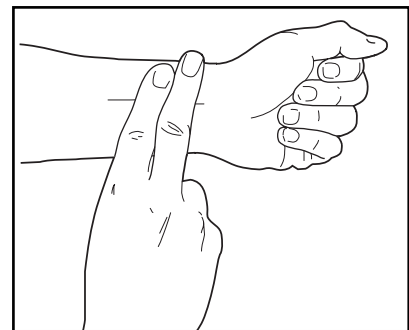

Adjust the intensity of your exercise until your heart rate is at the desired level. You can adjust the intensity of your exercise by adjusting the resistance or by changing your pace.

## WORKOUT GUIDELINES

Each workout should include the following three parts:

**A warm-up**, lasting 5 to 10 minutes. Begin with slow, controlled stretches, and progress to more rhythmic stretches to increase the body temperature, heart rate, and circulation in preparation for strenuous exercise.

**Training zone exercise**, consisting of 20 to 30 minutes of exercising with your heart rate in your training zone.

**A cool-down**, with 5 to 10 minutes of stretching. Thorough stretching helps to offset problems caused

when you stop exercising suddenly. Stretching for increased flexibility is also most effective after exercising. A proper cool-down should leave you relaxed and comfortably tired.

## EXERCISE FREQUENCY

To maintain or improve your condition, plan three workouts each week, with at least one day of rest between workouts. After a few months of regular exercise, you may complete up to five workouts each week, if desired.

Remember, the key to success is make exercise a regular and enjoyable part of your everyday life.

## SUGGESTED STRETCHES

The correct form for several basic stretches is shown in the drawings below. Move slowly as you stretch—never bounce.

### 1. Toe Touch Stretch

Stand with your knees bent slightly and slowly bend forward from your hips. Allow your back and shoulders to relax as you reach down toward your toes as far as possible. Hold for 15 counts, then relax. Repeat 3 times. Stretches: Hamstrings, back of knees and back.

### 2. Hamstring Stretch

Sit with one leg extended. Bring the sole of the opposite foot toward you and rest it against the inner thigh of your extended leg. Reach toward your toes as far as possible. Hold for 15 counts, then relax. Repeat 3 times for each leg. Stretches: Hamstrings, lower back and groin.

### 3. Calf/Achilles Stretch

With one leg in front of the other, reach forward and place your hands against a wall. Keep your back leg straight and your back foot flat on the floor. Bend your front leg, lean forward and move your hips toward the wall. Hold for 15 counts, then relax. Repeat 3 times for each leg. To cause further stretching of the achilles tendons, bend your back leg as well. Stretches: Calves, achilles tendons and ankles.

### 4. Quadriceps Stretch

With one hand against a wall for balance, reach back and grasp one foot with your other hand. Bring your heel as close to your buttocks as possible. Hold for 15 counts, then relax. Repeat 3 times for each leg. Stretches: Quadriceps and hip muscles.

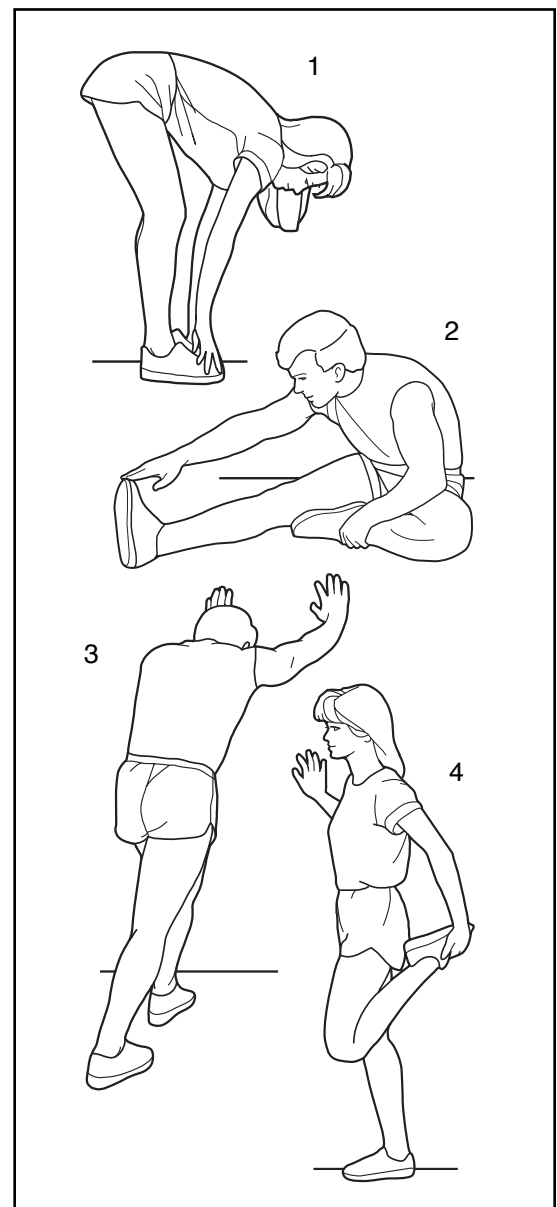

# PART LIST—Model No. WLEL36070

R1297A

Key No.	Qty.	Description	Key No.	Qty.	Description
1	1	Frame	42	1	7/8" Nut
2	1	Upright	43	1	M23 Keyed Washer
3	1	Reed Switch Wire	44	1	7/8" Crank Nut
4	1	Stabilizer	45	2	M10 x 75mm Button Head Bolt
5	1	Left Side Shield	46	2	M10 Nylon Locknut
6	1	Right Side Shield	47	4	2 1/5" Stabilizer Endcap
7	1	Left Pedal Arm	48	2	60mm Stabilizer Inner Endcap
8	1	Right Pedal Arm	49	1	Resistance Belt Clamp
9	2	Pedal	50	1	Driver Belt
10	1	Left Handlebar	51	10	M4 x 16mm Screw
11	1	Right Handlebar	52	2	Flywheel Washer
12	2	Foam Handgrip	53	1	Crank Shaft
13	1	Console	54	1	Flywheel
14	1	Battery Cover	55	2	Eyebolt
15	1	Extension Wire	56	2	Adjustment Bracket
16	1	Pedal Resistance Knob	57	2	Adjustment Nut
17	1	Resistance Control/Cable	58	1	Axle
18	1	Tension Control Cover	59	2	Wheel Cover
19	1	Return Spring	60	2	Wheel
20	1	M5 x 11mm Screw	61	4	Wheel Bearing
21	4	M6 Washer	62	2	1/4" Split Washer
22	1	M5 Nut	63	2	M8 x 55mm Hex Head Bolt
23	1	Tension Spring	64	2	M8 Nylon Locknut
24	1	Resistance Belt	65	2	Pedal Bar Endcap
25	3	M10 x 25mm Button Head Screw	66	6	M4 x 38mm Screw
26	1	Upright Bracket	67	1	Pulley
27	2	M6 x 1" Hex Head Screw	68	2	M8 Nut
28	2	Handlebar Cap/Friction Pad	69	3	M10 Split Washer
29	1	Star Washer	70	2	Bumpers
30	1	Handlebar Resistance Knob	71	1	Magnet
31	1	Lock Pin	72	1	Knob Cover Decal
32	1	M10 x 150mm Carriage Bolt	73	2	1 1/4" Round Inner Endcap
33	4	Console Screw	74	4	M8 Washer
34	1	M4 x 16mm Flat Head Screw	75	1	Large Crank Washer
35	4	Pedal Bar Bushing	76	2	Small Crank Washer
36	2	Pedal Bolt	77	2	5/16" x 3/4" Screw
37	2	1/2" Nylon Locknut	78	2	Crank Cover
38	2	Crank Arm	79	4	Wheel Spacer
39	1	Triple Notch Bearing Nut	#	1	User's Manual
40	2	Crank Bearing	#	1	Allen Wrench
41	2	Bearing Cup	#	1	Flat Wrench

Note: “#” indicates a non-illustrated part. Specifications are subject to change without notice. See the back cover of this manual for information about ordering replacement parts.



# EXPLODED DRAWING—Model No. WLEL36070

R1297A

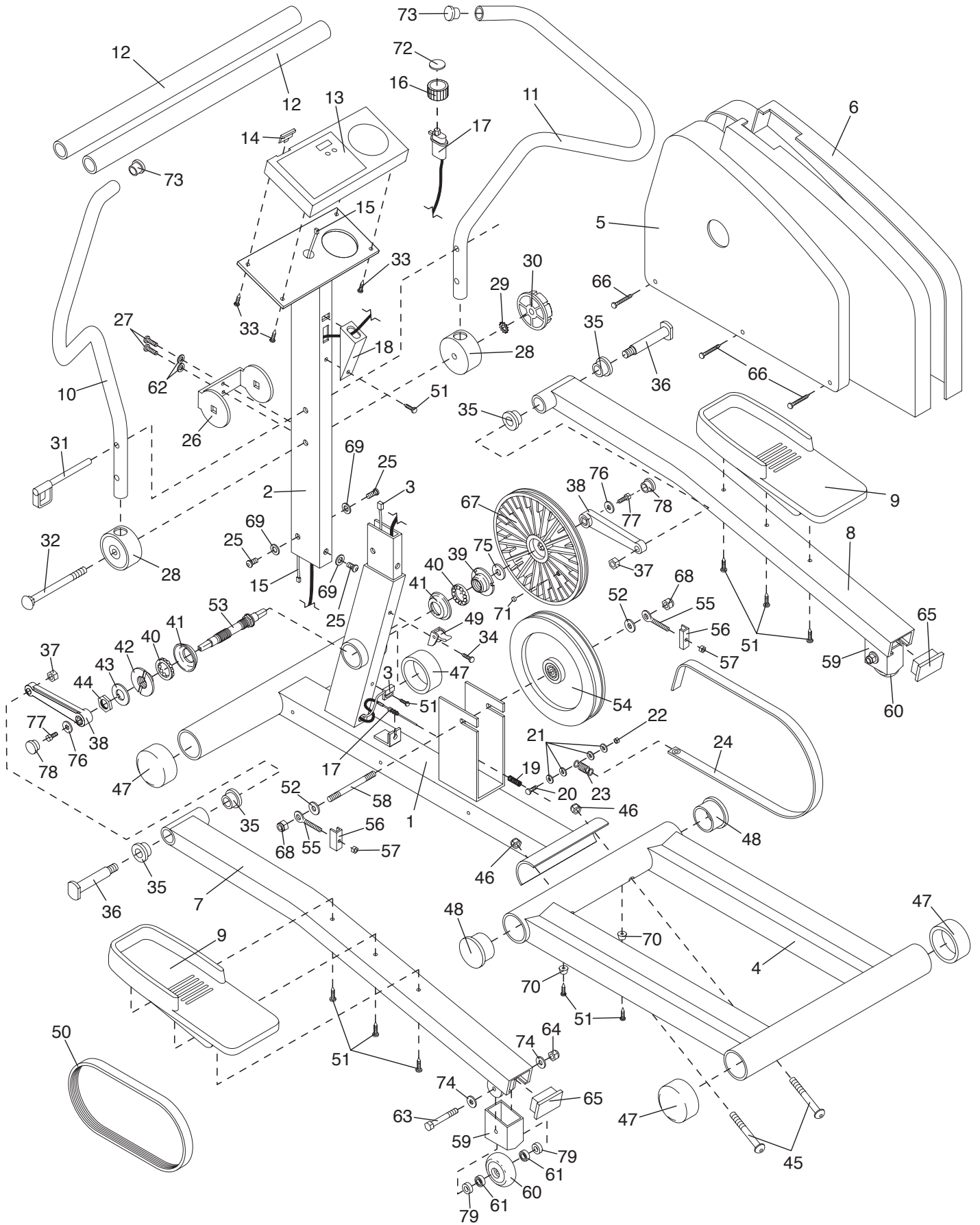

---

# HOW TO ORDER REPLACEMENT PARTS

To order replacement parts, simply call our Customer Service Department toll-free at 1-800-999-3756, Monday through Friday, 6 a.m. until 6 p.m. Mountain Time (excluding holidays). To help us assist you, please be prepared to give the following information when calling:

- The MODEL NUMBER of the product (WLEL36070).
- The NAME of the product (WESLO® ECLIPSE low-impact elliptical exerciser).
- The SERIAL NUMBER of the product (see the front cover of this manual).
- The KEY NUMBER and DESCRIPTION of the part(s) from page 14 of this manual.

WESLO® is a registered trademark of ICON Health & Fitness, Inc.

## LIMITED WARRANTY

ICON Health & Fitness, Inc. (ICON), warrants this product to be free from defects in workmanship and material, under normal use and service conditions, for a period of ninety (90) days from the date of purchase. This warranty extends only to the original purchaser. ICON's obligation under this warranty is limited to replacing or repairing, at ICON's option, the product through one of its authorized service centers. All repairs for which warranty claims are made must be pre-authorized by ICON. This warranty does not extend to any product or damage to a product caused by or attributable to freight damage, abuse, misuse, improper or abnormal usage or repairs not provided by an ICON authorized service center, products used for commercial or rental purposes, or products used as store display models. No other warranty beyond that specifically set forth above is authorized by ICON.

ICON is not responsible or liable for indirect, special or consequential damages arising out of or in connection with the use or performance of the product or damages with respect to any economic loss, loss of property, loss of revenues or profits, loss of enjoyment or use, costs of removal, installation or other consequential damages of whatsoever nature. Some states do not allow the exclusion or limitation of incidental or consequential damages. Accordingly, the above limitation may not apply to you.

The warranty extended hereunder is in lieu of any and all other warranties and any implied warranties of merchantability or fitness for a particular purpose is limited in its scope and duration to the terms set forth herein. Some states do not allow limitations on how long an implied warranty lasts. Accordingly, the above limitation may not apply to you.

This warranty gives you specific legal rights. You may also have other rights which vary from state to state.

**ICON HEALTH & FITNESS, INC., 1500 S. 1000 W., LOGAN, UT 84321-9813**



## Free Manuals Download Website

<http://myh66.com>

<http://usermanuals.us>

<http://www.somanuals.com>

<http://www.4manuals.cc>

<http://www.manual-lib.com>

<http://www.404manual.com>

<http://www.luxmanual.com>

<http://aubethermostatmanual.com>

Golf course search by state

<http://golfingnear.com>

Email search by domain

<http://emailbydomain.com>

Auto manuals search

<http://auto.somanuals.com>

TV manuals search

<http://tv.somanuals.com>