

WESLO[®] MOMENTUM 725

Model No. WLEL7397.1

Serial No. _____

Write the serial number in the space above for reference.

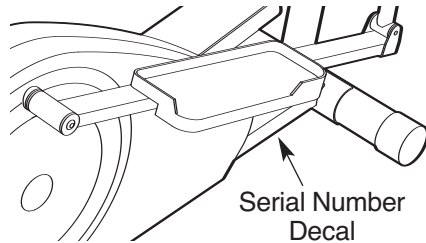

USER'S MANUAL

QUESTIONS?

As a manufacturer, we are committed to providing complete customer satisfaction. If you have questions, or if parts are damaged or missing, **PLEASE DO NOT CONTACT THE STORE; please contact Customer Care.**

IMPORTANT: You must note the product model number and serial number (see the drawing above) before contacting us:

CALL TOLL-FREE:

1-866-699-3756

Mon.-Fri. 6 a.m.-6 p.m. MST

Sat. 8 a.m.-4 p.m. MST

ON THE WEB:

www.wesloservice.com

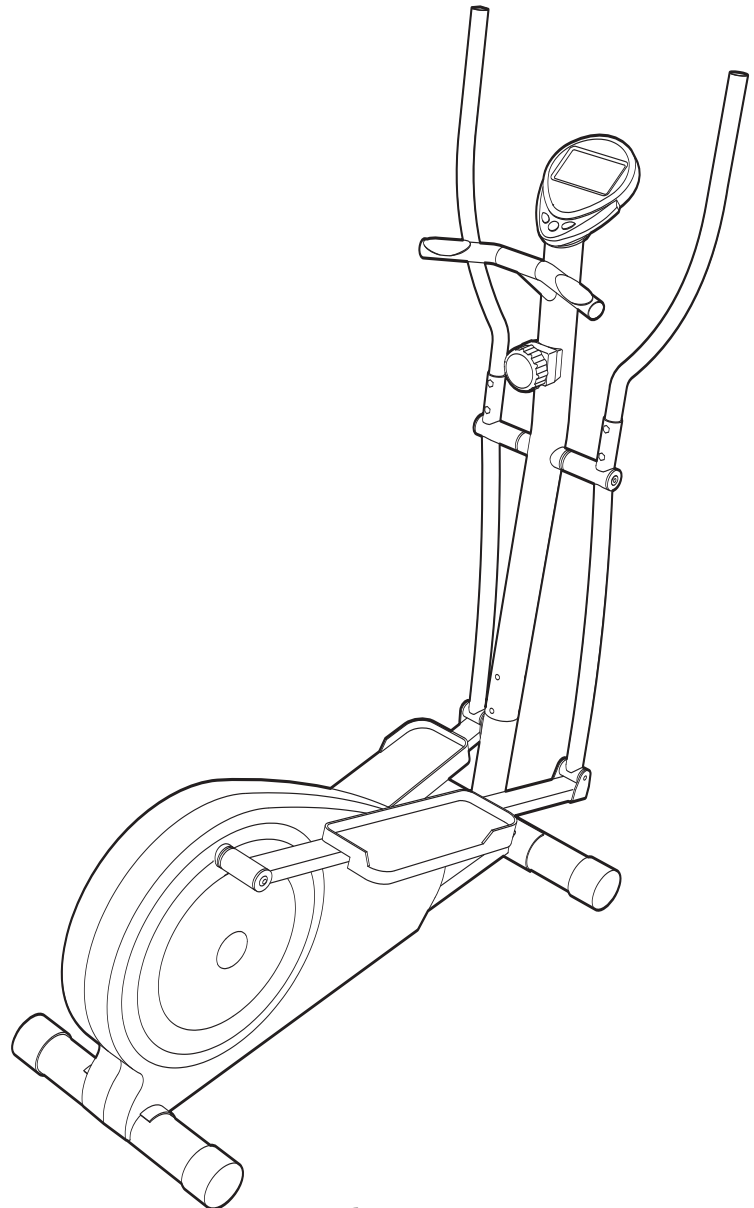

CAUTION

Read all precautions and instructions in this manual before using this equipment. Keep this manual for future reference.



Visit our website at

www.weslo.com

new products, prizes,
fitness tips, and much more!

TABLE OF CONTENTS

WARNING DECAL PLACEMENT	2
IMPORTANT PRECAUTIONS	3
BEFORE YOU BEGIN	4
ASSEMBLY	5
HOW TO USE THE ELLIPTICAL EXERCISER	8
MAINTENANCE AND TROUBLESHOOTING	10
EXERCISE GUIDELINES	11
PART LIST	14
EXPLODED DRAWING	15
ORDERING REPLACEMENT PARTS	Back Cover
LIMITED WARRANTY	Back Cover

WARNING DECAL PLACEMENT

The warning decal shown here has been applied in the indicated location. **If the decal is missing or illegible, see the front cover of this manual and request a free replacement decal. Apply the decal in the location shown.** Note: The decal may not be shown at actual size.

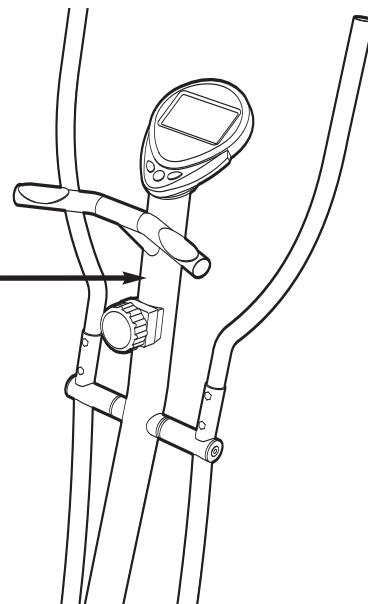
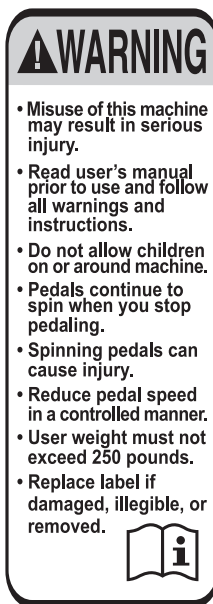

IMPORTANT PRECAUTIONS

⚠️ WARNING: To reduce the risk of serious injury, read all important precautions and instructions in this manual and all warnings on the elliptical exerciser before using the elliptical exerciser. ICON assumes no responsibility for personal injury or property damage sustained by or through the use of this product.

1. Before beginning any exercise program, consult your physician. This is especially important for persons over the age of 35 or persons with pre-existing health problems.
2. It is the responsibility of the owner to ensure that all users of the elliptical exerciser are adequately informed of all precautions.
3. The elliptical exerciser is intended for home use only. Do not use the elliptical exerciser in a commercial, rental, or institutional setting.
4. Keep the elliptical exerciser indoors, away from moisture and dust. Place the elliptical exerciser on a level surface, with a mat beneath it to protect the floor or carpet. Make sure that there is enough clearance around the elliptical exerciser to mount, dismount, and use it.
5. Inspect and properly tighten all parts regularly. Replace any worn parts immediately.
6. Keep children under age 12 and pets away from the elliptical exerciser at all times.
7. The elliptical exerciser should not be used by persons weighing more than 250 lbs. (113 kg).
8. Wear appropriate exercise clothes while exercising; do not wear loose clothes that could become caught on the elliptical exerciser. Always wear athletic shoes for foot protection.
9. Hold the handgrip pulse sensor or the handlebars when mounting, dismounting, or using the elliptical exerciser.
10. Keep your back straight while using the elliptical exerciser; do not arch your back.
11. The pulse sensor is not a medical device. Various factors, including the user's movement, may affect the accuracy of heart rate readings. The pulse sensor is intended only as an exercise aid in determining heart rate trends in general.
12. When you stop exercising, allow the pedals to slowly come to a stop.
13. If you feel pain or dizziness while exercising, stop immediately and cool down.
14. Use the elliptical exerciser only as described in this manual.

BEFORE YOU BEGIN

Thank you for selecting the WESLO® MOMENTUM 725 elliptical exerciser. The MOMENTUM 725 elliptical exerciser is designed to make your workouts at home more effective and enjoyable.

For your benefit, read this manual carefully before you use the elliptical exerciser. If you have questions after reading this manual, please see the front cover of this manual. To help us assist you, note the product model number and serial number before con-

tacting us. The model number and the location of the serial number decal are shown on the front cover of this manual.

To avoid a registration fee for any service needed under warranty, you must register the elliptical exerciser at www.wesloservice.com/registration.

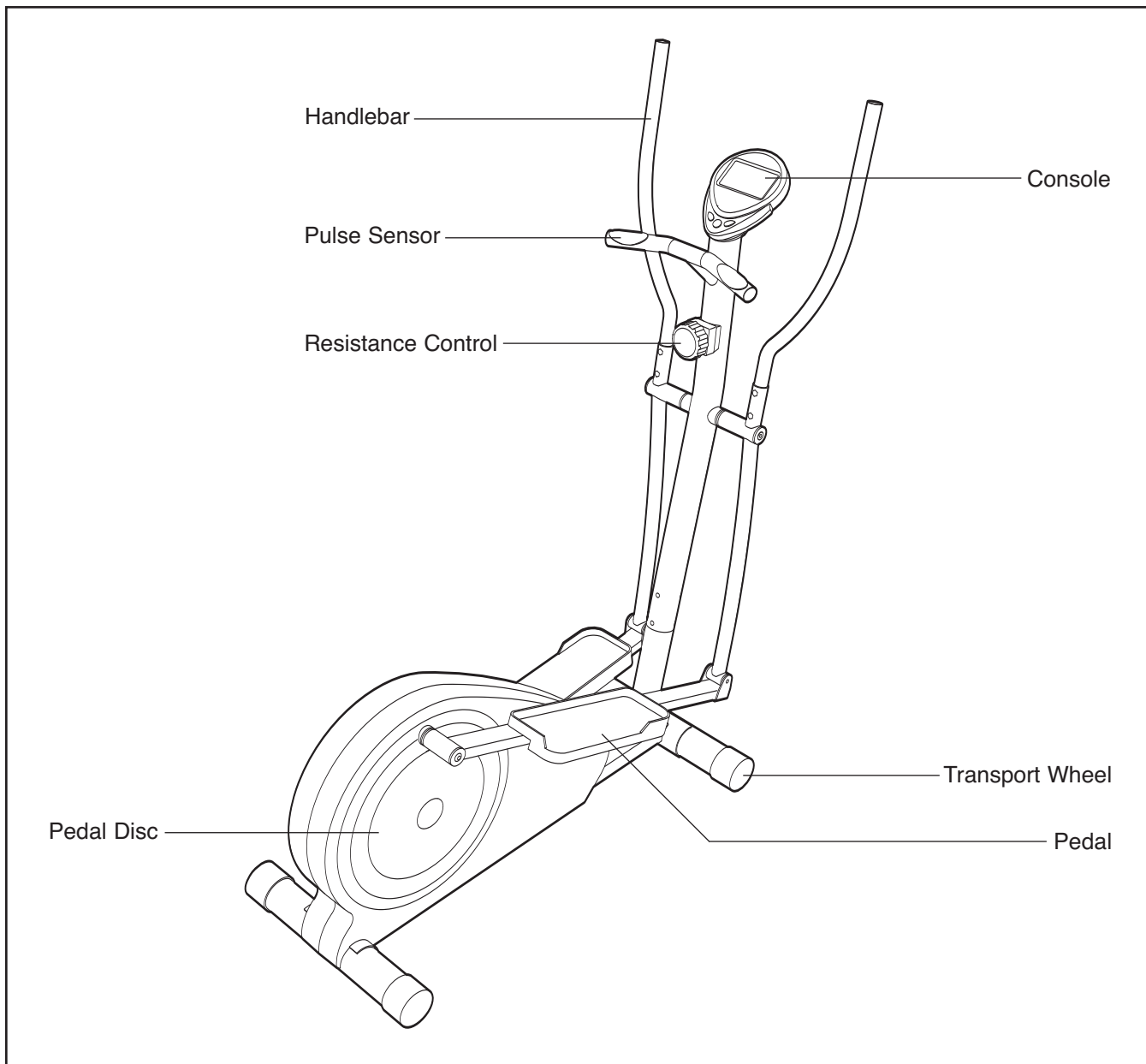

Before reading further, please familiarize yourself with the parts that are labeled in the drawing below.



ASSEMBLY

To hire an authorized service technician to assemble the elliptical exerciser, call 1-800-445-2480.

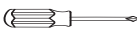
Assembly requires two persons. Place all parts of the elliptical exerciser in a cleared area and remove the packing materials. Do not dispose of the packing materials until assembly is completed.

Assembly requires a Phillips screwdriver  **and two adjustable wrenches** .

1. Identify the Front Stabilizer (2), which has Transport Wheels (29) attached to it. Attach the Front Stabilizer to the Frame (1) with two M8 x 3 1/2" Carriage Bolts (51), two M8 Arc Washers (54), and two M8 Cap Nuts (24).

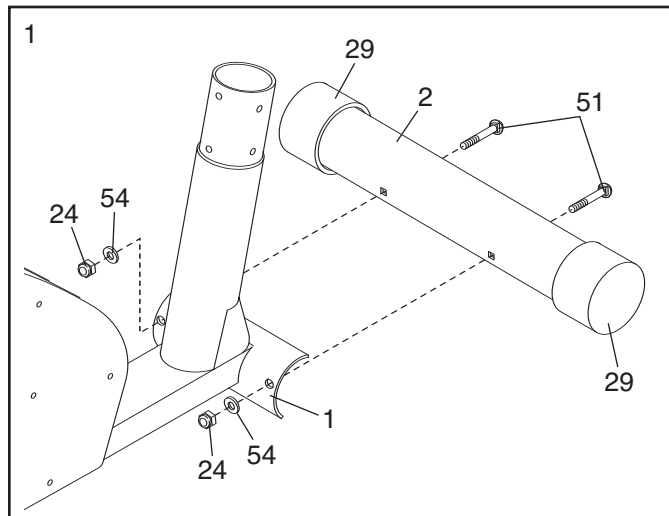

2. Tip the Frame (1) forward onto its front end as shown. While another person holds the Frame, attach the Rear Stabilizer (20) to the Frame with two M8 x 3 3/8" Hex Bolts (42).

With the help of another person, tip the Frame (1) down so that it is resting on the Front and Rear Stabilizers (2, 20).

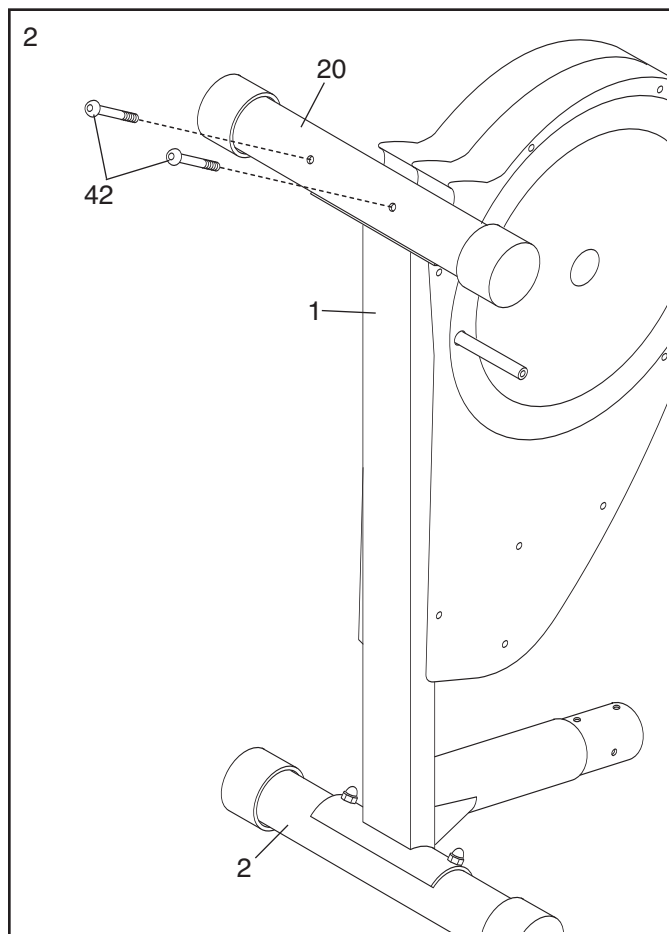

- While another person holds the Upright (3) near the Frame (1), connect the Upper Wire (75) to the Reed Switch Wire (67). Next, connect the Resistance Cable (12) to the Lower Cable (70) in the following way:

See drawing A. Pull up on the metal bracket (A) on the Lower Cable (70), and insert the tip of the Resistance Cable (12) into the wire clip located inside the metal bracket.

See drawing B. Firmly pull the Resistance Cable (12) and slide it into the metal bracket (A) on the Lower Cable (70) as shown.

See drawing C. Using pliers, squeeze the prongs on the upper end of the metal bracket (A) together.

Slide the Upright (3) onto the Frame (1). **Be careful to avoid pinching the cables or the wires.** Align the holes in the Upright with the holes in the Frame. Attach the Upright with six M8 x 5/8" Hex Bolts (45) and six M8 Arc Washers (54).

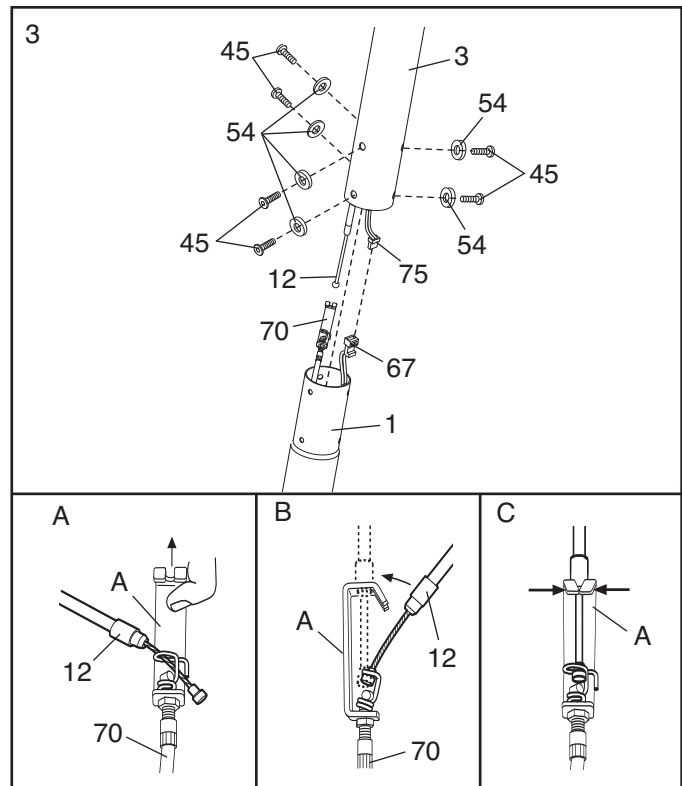

- The Console (22) requires two 1.5V "AA" batteries (not included). Remove the battery cover from the Console and insert two batteries into the battery compartment. **Make sure that the batteries are oriented as shown by the diagram inside the battery compartment.** Then, reattach the battery cover.

Have a second person hold the Console (22) near the Upright (3). Connect the console wire to the Upper Wire (75). Connect the two pulse wires on the console to the Pulse Wires (74). Insert the excess wire downward into the Upright.

Attach the Console (22) to the Upright (3) with four Console Screws (68). **Be careful to avoid pinching the wires.**

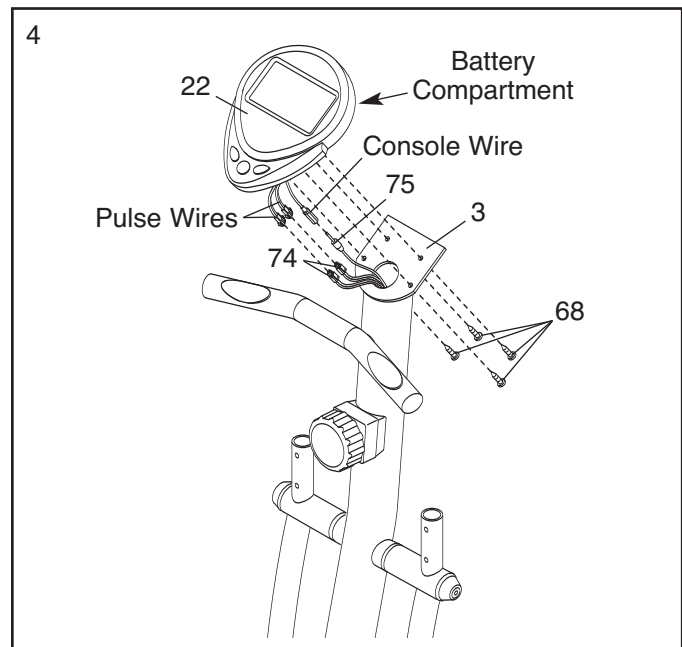

5. Identify the Right Pedal (63), which has an "R" molded into its bottom surface.

Attach the Right Pedal (63) to the Right Pedal Tube (64) with two M8 x 1 9/16" Hex Bolts (41), two M8 Washers (52), and two M8 Nylon Locknuts (57).

Attach the Left Pedal (not shown) to the Left Pedal Tube (not shown) in the same way.

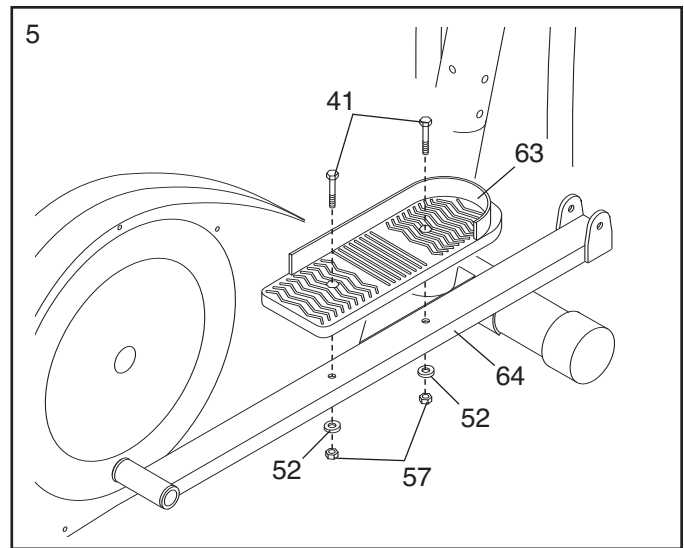

6. Apply a small amount of the included grease to the parts shown at the right.

Attach the Right Pedal Tube (64) to the Right Handlebar Leg (71) with an M8 x 2 1/2" Shoulder Hex Bolt (40), an M6 Washer (55), and an M6 Nylon Locknut (56).

Repeat this step to attach the Left Pedal Tube (not shown) to the left side of the elliptical exerciser.

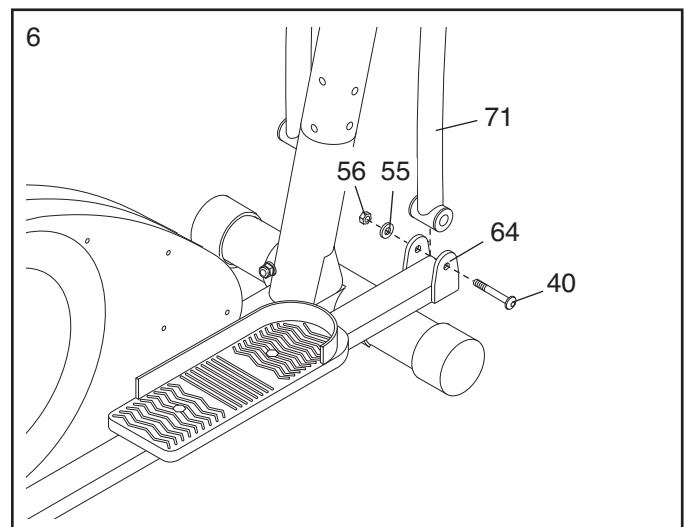

7. Insert a Plastic Sleeve (16) into the top of the Right Handlebar Leg (71). Then, insert a Handlebar (6) into the Right Handlebar Leg. Align the holes in the Handlebar with the holes in the Right Handlebar Leg. Attach the Handlebar with two M6 x 5/8" Pocket Screws (46), two M6 Arc Washers (39), and two M6 Nylon Locknuts (56).

Attach the other Handlebar (6) to the Left Handlebar Leg (5) in the same way.

8. **Make sure that all parts of the elliptical exerciser are properly tightened.** Note: Some hardware may be left over after assembly is completed. To protect the floor or carpet from damage, place a mat under the elliptical exerciser.

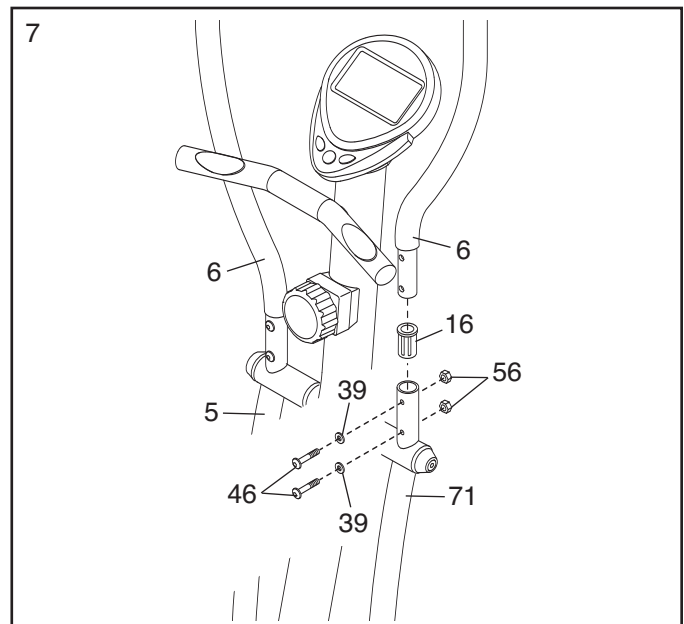

HOW TO USE THE ELLIPTICAL EXERCISER

HOW TO MOVE THE ELLIPTICAL EXERCISER

To move the elliptical exerciser, stand in front of it, place one foot against one of the wheels, and firmly hold the upper end of the upright. Pull the upright forward until you can move the elliptical exerciser on the wheels. Carefully move the elliptical exerciser to the desired location and then lower it to the floor. **To decrease the risk of injury, do not attempt to move the elliptical exerciser over an uneven surface.**

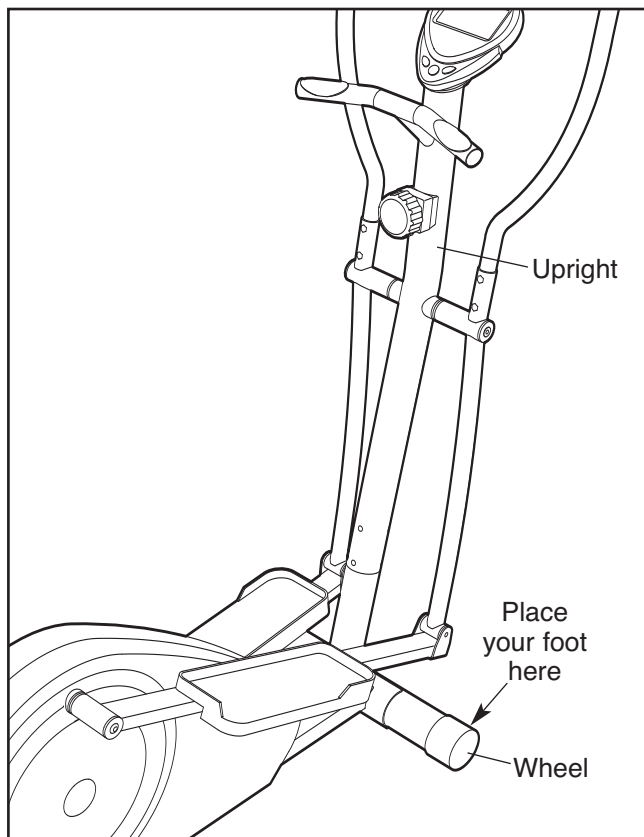

HOW TO EXERCISE ON THE ELLIPTICAL EXERCISER

To mount the elliptical exerciser, hold the handlebars and step onto the pedal that is in the lowest position. Next, step onto the other pedal. Push the pedals until they begin to move with a continuous motion. **Note: The pedal discs can turn in either direction. It is recommended that you turn the pedal discs in the direction shown by the arrow below; however, for variety you can turn the pedal discs in the opposite direction.**

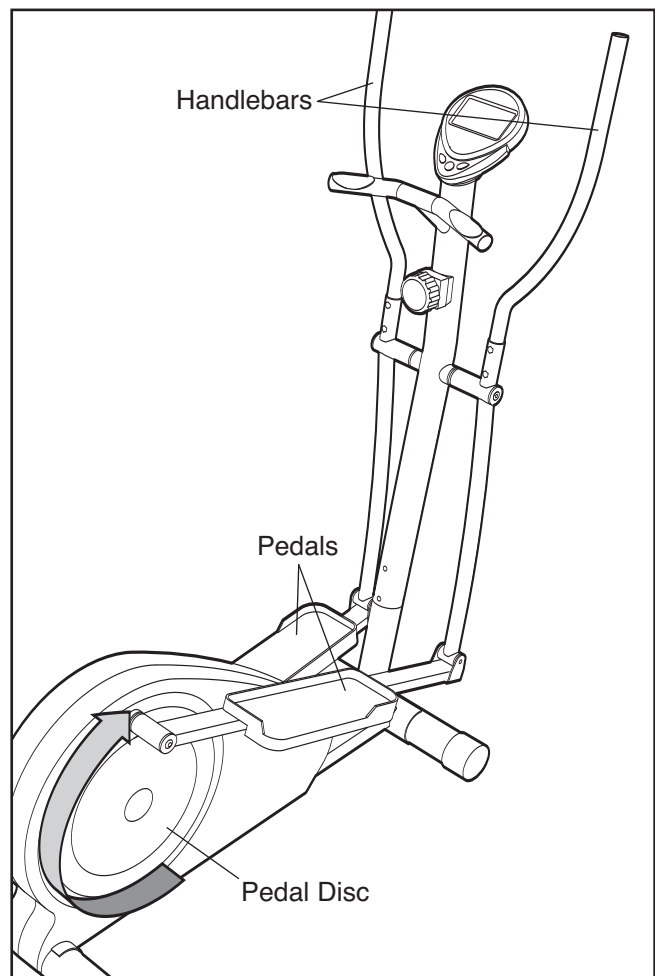

To dismount the elliptical exerciser, wait until the pedals come to a complete stop. **Note: The elliptical exerciser does not have a free wheel; the pedals will continue to move until the flywheel stops.** When the pedals are stationary, step off the higher pedal first. Then, step off the lower pedal.

HOW TO ADJUST THE RESISTANCE

As you exercise, you can adjust the resistance of the pedals with the resistance control on the upright. To increase the resistance, turn the control clockwise; to decrease the resistance, turn the control counter-clockwise.

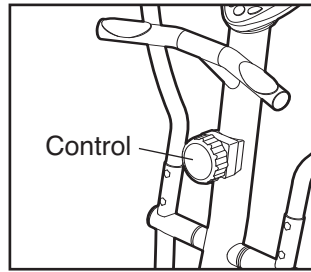

FEATURES OF THE CONSOLE

The easy-to-use console features five displays that provide instant exercise feedback during your workouts. The displays are described below.



Speed—This display shows your pedaling speed, in miles or kilometers per hour.

Time—This display shows the elapsed time. Note: If you set a time goal (see step 2), this mode will display the time remaining in your workout.

Distance—This display shows the distance you have pedaled during your workout, in miles or kilometers. Note: If you set a distance goal (see step 2), this display will show the distance remaining in your workout.

Calorie—This display shows the approximate number of calories you have burned during your workout. Note: If you set a calorie-burning goal (see step 2), this display will show the number of calories still to be burned in your workout.

Pulse—This display shows your heart rate in beats per minute when the console detects your pulse. When no pulse is detected, a “P” will appear in the display.

HOW TO USE THE CONSOLE

Make sure that the console has batteries (see assembly step 4 on page 6). If there is a sheet of clear plastic on the face of the console, remove it.

Note: You can set the console to display speed and distance in either kilometers or miles. When you insert batteries into the console, a “1” will begin to flash in the Speed display. While the “1” is flashing, you can press the MODE button repeatedly to switch between “1” (kilometers) and “2” (miles). A few seconds after you have selected “1” or “2,” the unit of measurement will be set.

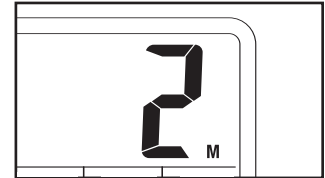

Follow the steps below to operate the console.

1. Turn on the console.

To turn on the console, press any button on the console or simply begin pedaling.

2. Set a workout goal, if desired.

To set a time, distance, or calorie-burning goal for your workout, press the MODE button repeatedly until the word SET begins to flash in the Time, Distance, or Calorie display.

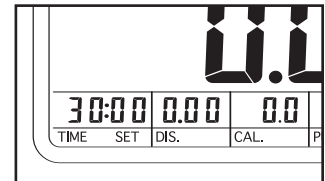

Next, press the SET button repeatedly to set a goal. To set a goal quickly, hold down the SET button. To reset the goal, press the RESET button while the word SET is flashing in the display.

3. Begin pedaling and follow your progress with the displays.

As you exercise, the console will provide instant feedback about your workout. If you have set a workout goal, a tone will sound for several seconds when you reach your goal; if you continue to exercise, the display will begin to count upward.

4. Measure your heart rate, if desired.

If there are sheets of clear plastic on the metal contacts of the handgrip pulse sensor, peel off the plastic.

Place your hands on the handgrip pulse sensor, with your palms on the contacts. **Avoid moving your hands.** When your pulse is detected, your heart rate will be shown.

For the most accurate heart rate reading, continue to hold the handgrips for about 30 seconds.

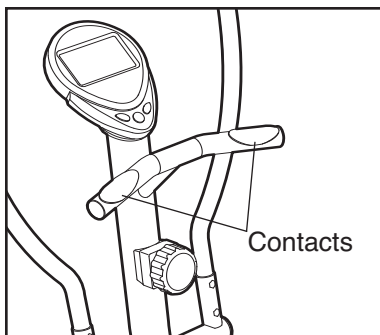

If your heart rate is not shown, make sure that your hands are positioned as described. Avoid moving your hands excessively or squeezing the metal contacts too tightly. For optimal performance, periodically clean the metal contacts using a soft cloth; **never use alcohol, abrasives, or chemicals to clean the contacts.**

5. When you are finished exercising, the console will turn off automatically.

If the pedals do not move for a few seconds, the console displays will pause.

The console has an “auto-off” feature. If the pedals do not move and the console buttons are not pressed for a few minutes, the power will turn off automatically to save the batteries.

MAINTENANCE AND TROUBLESHOOTING

Inspect and tighten all parts of the elliptical exerciser regularly. Replace any worn parts immediately.

To clean the elliptical exerciser, use a damp cloth and a small amount of mild soap. **IMPORTANT: To avoid damage to the console, keep liquids away from the console and keep the console out of direct sunlight.**

BATTERY REPLACEMENT

If the console displays become dim, the batteries should be replaced; most console problems are the

result of low batteries. See assembly step 4 on page 6 for replacement instructions.

HANDGRIP PULSE SENSOR TROUBLESHOOTING

If the handgrip pulse sensor does not function properly, see step 4 above.

EXERCISE GUIDELINES

⚠ WARNING: Before beginning this or any exercise program, consult your physician. This is especially important for persons over the age of 35 or persons with pre-existing health problems.

The pulse sensor is not a medical device. Various factors may affect the accuracy of heart rate readings. The pulse sensor is intended only as an exercise aid in determining heart rate trends in general.

These guidelines will help you to plan your exercise program. For detailed exercise information, obtain a reputable book or consult your physician. Remember, proper nutrition and adequate rest are essential for successful results.

EXERCISE INTENSITY

Whether your goal is to burn fat or to strengthen your cardiovascular system, exercising at the proper intensity is the key to achieving results. You can use your heart rate as a guide to find the proper intensity level. The chart below shows recommended heart rates for fat burning and aerobic exercise.

165	155	145	140	130	125	115	♥
145	138	130	125	118	110	103	♥
125	120	115	110	105	95	90	♥
<hr/>							
20	30	40	50	60	70	80	

To find the proper intensity level, find your age at the bottom of the chart (ages are rounded off to the nearest ten years). The three numbers listed above your age define your “training zone.” The lowest number is the heart rate for fat burning, the middle number is the heart rate for maximum fat burning, and the highest number is the heart rate for aerobic exercise.

Burning Fat—To burn fat effectively, you must exercise at a low intensity level for a sustained period of time. During the first few minutes of exercise, your body uses *carbohydrate calories* for energy. Only after the first few minutes of exercise does your body begin to use stored *fat calories* for energy. If your goal is to burn fat, adjust the intensity of your exercise until your heart rate is near the lowest number in your training zone. For maximum fat burning, exercise with your heart rate near the middle number in your training zone.

Aerobic Exercise—If your goal is to strengthen your cardiovascular system, you must perform aerobic exercise, which is activity that requires large amounts of oxygen for prolonged periods of time. For aerobic exercise, adjust the intensity of your exercise until your heart rate is near the highest number in your training zone.

WORKOUT GUIDELINES

Warming up—Start with 5 to 10 minutes of stretching and light exercise. A warm-up increases your body temperature, heart rate, and circulation in preparation for exercise.

Training Zone Exercise—Exercise for 20 to 30 minutes with your heart rate in your training zone. (During the first few weeks of your exercise program, do not keep your heart rate in your training zone for longer than 20 minutes.) Breathe regularly and deeply as you exercise—never hold your breath.

Cooling down—Finish with 5 to 10 minutes of stretching. Stretching increases the flexibility of your muscles and helps to prevent post-exercise problems.

EXERCISE FREQUENCY

To maintain or improve your condition, complete three workouts each week, with at least one day of rest between workouts. After a few months of regular exercise, you may complete up to five workouts each week, if desired. Remember, the key to success is to make exercise a regular and enjoyable part of your everyday life.

NOTES

NOTES

PART LIST—Model No. WLEL7397.1

R0108A

Key No.	Qty.	Description	Key No.	Qty.	Description
1	1	Frame	39	4	M6 Arc Washer
2	1	Front Stabilizer	40	2	M8 x 2 1/2" Shoulder Hex Bolt
3	1	Upright	41	4	M8 x 1 9/16" Hex Bolt
4	1	Left Pedal Tube	42	2	M8 x 3 3/8" Hex Bolt
5	1	Left Handlebar Leg	43	1	M8 x 2 3/8" Hex Bolt
6	2	Handlebar	44	1	M8 x 2 3/8" Tap Hex Bolt
7	1	Flywheel	45	6	M8 x 5/8" Hex Bolt
8	1	Left Pedal	46	4	M6 x 5/8" Pocket Screw
9	1	Flywheel Axle	47	10	M5 x 5/8" Pocket Screw
10	1	"C"-magnet	48	5	M4 x 1 9/16" Pocket Screw
11	2	Upright Spacer	49	1	M5 x 1 1/4" Screw
12	1	Resistance Control/Cable	50	4	Wave Washer
13	2	Handlebar Endcaps	51	2	M8 x 3 1/2" Carriage Bolt
14	1	Drivr Wheel Assembly	52	5	M8 Washer
15	1	Right Crank Arm	53	4	M10 Washer
16	2	Plastic Sleeves	54	8	M8 Arc Washer
17	8	Handlebar Bushing	55	2	M6 Washer
18	1	Spring	56	8	M6 Nylon Locknut
19	2	Foam Handle Grip	57	7	M8 Nylon Locknut
20	1	Rear Stabilizer	58	1	M10 Nylon Locknut
21	1	Left Side Shield	59	1	M8 Hex Nut
22	1	Console	60	1	Magnet
23	4	Leg Bushing	61	2	M3 x 1/2" Pocket Screw
24	2	M8 Cap Nut	62	2	M10 Spacer
25	1	Left Disc Cover	63	1	Right Pedal
26	4	M8 x 3/4" Hex Bolt	64	1	Right Pedal Tube
27	2	Bearing Cover	65	1	Right Side Shield
28	2	Rear Stabilizer Endcap	66	1	Right Disc Cover
29	2	Transport Wheel	67	1	Reed Switch/Wire
30	1	Drive Belt	68	5	Console Screw
31	2	Plastic Washer	69	1	Reed Switch Bracket
32	4	Nylon Bushing	70	1	Lower Cable
33	2	Flywheel Bearing	71	1	Right Handlebar Leg
34	2	Crank Bearing	72	2	Pulse Sensor
35	2	Pedal Tube Endcap	73	2	Pulse Screw
36	1	"C"-clip	74	1	Pulse Wire
37	2	Eyebolt	75	1	Upper Wire
38	2	Adjustment Bracket	*	—	User's Manual

Note: Specifications are subject to change without notice. See the back cover of this manual for information about ordering replacement parts. *These parts are not illustrated.

EXPLODED DRAWING—Model No. WLEL7397.1

R0108A

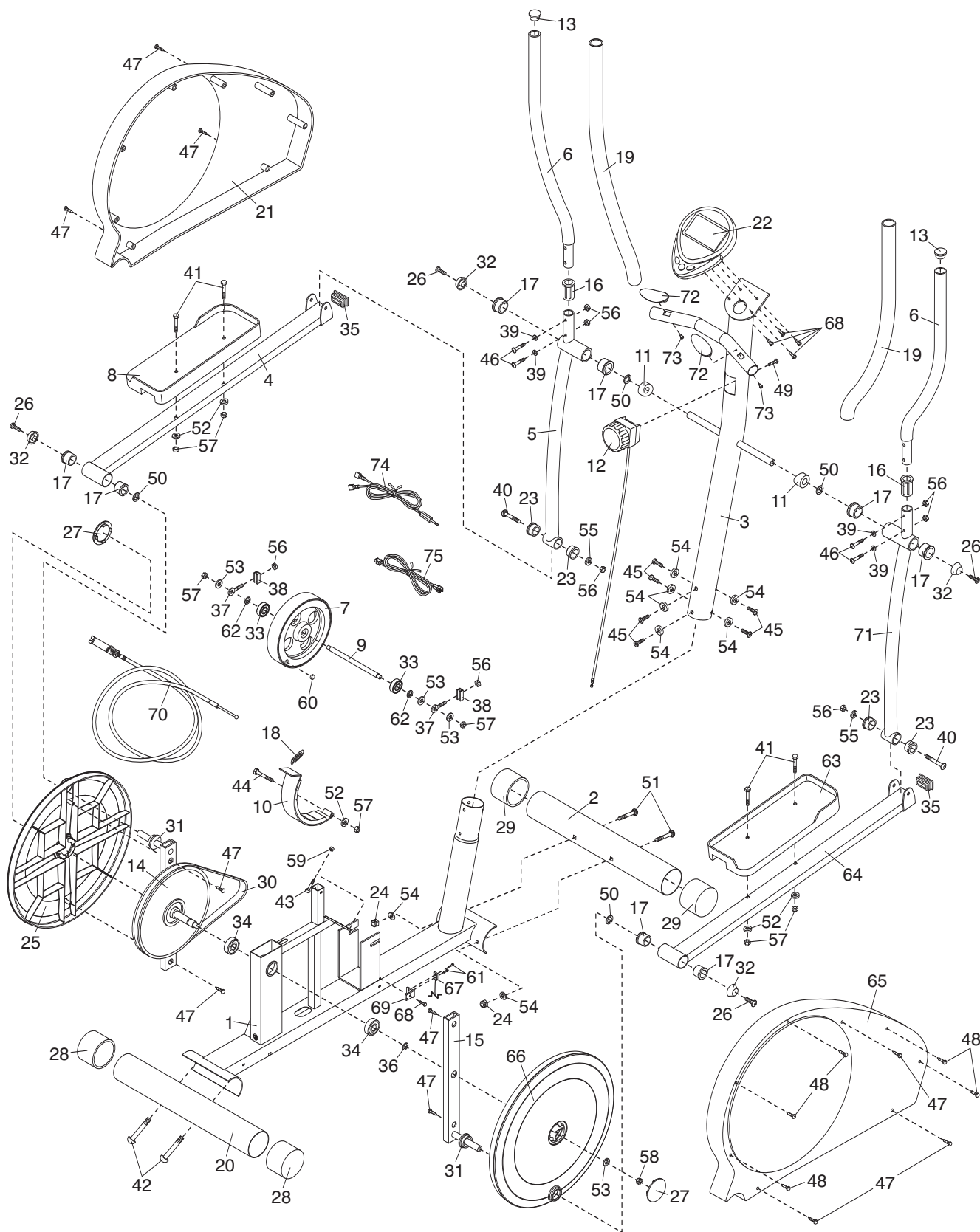

ORDERING REPLACEMENT PARTS

To order replacement parts, please see the front cover of this manual. To help us assist you, be prepared to provide the following information when contacting us:

- the model number and serial number of the product (see the front cover of this manual)
- the name of the product (see the front cover of this manual)
- the key number and description of the replacement part(s) (see the PART LIST and the EXPLODED DRAWING near the end of this manual)

LIMITED WARRANTY

ICON Health & Fitness, Inc. (ICON) warrants this product to be free from defects in workmanship and material, under normal use and service conditions, for a period of ninety (90) days from the date of purchase. This warranty extends only to the original purchaser. ICON's obligation under this warranty is limited to replacing or repairing, at ICON's option, the product through one of its authorized service centers. All repairs for which warranty claims are made must be preauthorized by ICON. If the product is shipped to a service center, freight charges to and from the service center will be the customer's responsibility. For in-home service, the customer will be responsible for a minimal trip charge. This warranty does not extend to any product or damage to a product caused by or attributable to freight damage, abuse, misuse, improper or abnormal usage or repairs not provided by an ICON authorized service center; products used for commercial or rental purposes; or products used as store display models. No other warranty beyond that specifically set forth above is authorized by ICON.

ICON is not responsible or liable for indirect, special or consequential damages arising out of or in connection with the use or performance of the product or damages with respect to any economic loss, loss of property, loss of revenues or profits, loss of enjoyment or use, costs of removal or installation or other consequential damages of whatsoever nature. Some states do not allow the exclusion or limitation of incidental or consequential damages. Accordingly, the above limitation may not apply to you.

The warranty extended hereunder is in lieu of any and all other warranties and any implied warranties of merchantability or fitness for a particular purpose is limited in its scope and duration to the terms set forth herein. Some states do not allow limitations on how long an implied warranty lasts. Accordingly, the above limitation may not apply to you.

This warranty gives you specific legal rights. You may also have other rights which vary from state to state.

ICON HEALTH & FITNESS, INC., 1500 S. 1000 W., LOGAN, UT 84321-9813

Free Manuals Download Website

<http://myh66.com>

<http://usermanuals.us>

<http://www.somanuals.com>

<http://www.4manuals.cc>

<http://www.manual-lib.com>

<http://www.404manual.com>

<http://www.luxmanual.com>

<http://aubethermostatmanual.com>

Golf course search by state

<http://golfingnear.com>

Email search by domain

<http://emailbydomain.com>

Auto manuals search

<http://auto.somanuals.com>

TV manuals search

<http://tv.somanuals.com>