

WESLO[®]

CADENCE AF 5.1

www.weslo.com

Model No. WLTL29911.0

Serial No. _____

Write the serial number in the space above for reference.

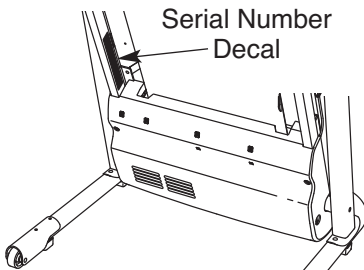

USER'S MANUAL

QUESTIONS?

If you have questions, or if parts are damaged or missing, **DO NOT CONTACT THE STORE**; please contact Customer Care.

IMPORTANT: Please register this product (see the limited warranty on the back cover of this manual) before contacting Customer Care.

CALL TOLL-FREE:

1-866-699-3756

Mon.–Fri. 6 a.m.–6 p.m. MT

Sat. 8 a.m.–4 p.m. MT

ON THE WEB:

www.wesloservice.com

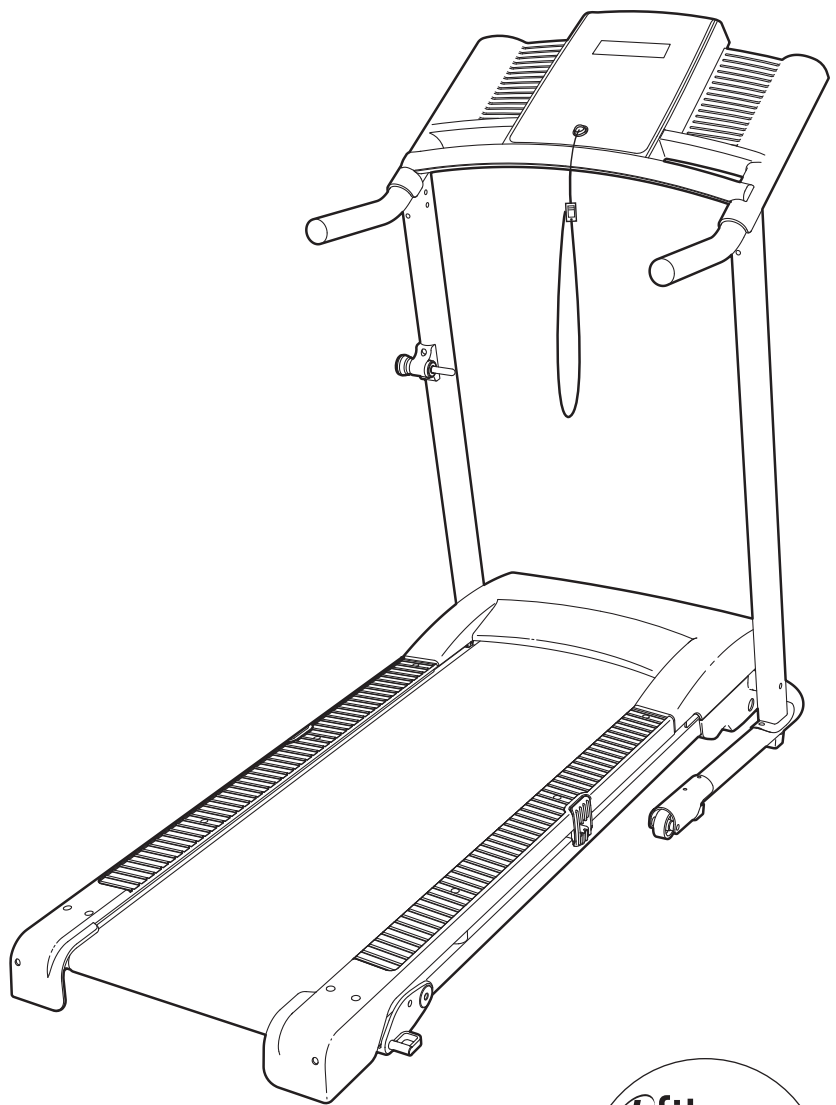

CAUTION

Read all precautions and instructions in this manual before using this equipment. Save this manual for future reference.

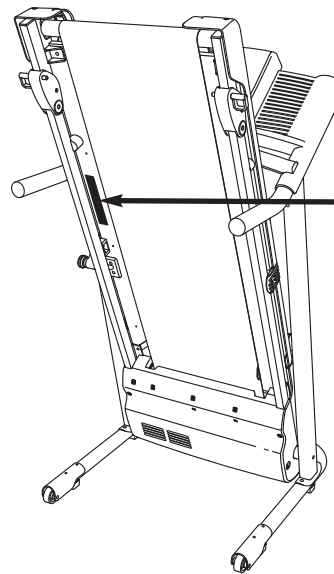

TABLE OF CONTENTS

WARNING DECAL PLACEMENT	2
IMPORTANT PRECAUTIONS	3
BEFORE YOU BEGIN	5
ASSEMBLY	6
OPERATION AND ADJUSTMENT	10
HOW TO FOLD AND MOVE THE TREADMILL	15
TROUBLESHOOTING	16
EXERCISE GUIDELINES	18
PART LIST	19
EXPLODED DRAWING	20
ORDERING REPLACEMENT PARTS	Back Cover
LIMITED WARRANTY	Back Cover

WARNING DECAL PLACEMENT

This drawing shows the location(s) of the warning decal(s). **If a decal is missing or illegible, call the telephone number on the front cover of this manual and request a free replacement decal. Apply the decal in the location shown.** Note: The decal(s) may not be shown at actual size.



▲WARNING:

Protect yourself and others from risk of serious injury. Read the user's manual and :

- ▲Stand only on the side rails when starting or stopping treadmill.
- ▲Change speed in small increments. Hold handrails to prevent falling, and always wear the safety clip while operating treadmill.
- ▲Stop if you feel faint, dizzy, or short of breath.
- ▲Fully engage storage lock before treadmill is moved or stored.
- ▲Reduce incline to its lowest level before folding treadmill into storage position.

- ▲Never allow children on or around treadmill.
- ▲Remove key when not in use.
- ▲Keep clothing, fingers, and hair away from moving belt.
- ▲Never try to adjust or fix the belt while it is moving.
- ▲Always wear an belt device while operating treadmill.

▲ADVERTENCIA:

Protégase y proteja a otros de riesgo de lesiones serias. Lea el manual del usuario y :

- ▲Póngase sólo en los rieles de apoyo para los pies al comenzar o cesar la cinta de correr.
- ▲Cambie la velocidad en aumentos pequeños.
- ▲Sostenga los tornos para prevenir caídas, y siempre use el dispositivo de seguridad mientras opera la cinta de correr.
- ▲Baje el ángulo de inclinación a su nivel más bajo antes de plegar la cinta de correr.

- ▲Nunca permita a los niños en o alrededor de la cinta de correr.
- ▲Quite la llave cuando no está en uso.
- ▲Mantenga ropa, dedos, y cabellos alejados de los componentes en movimiento.
- ▲Nunca trate de ajustar o arreglar la cinta mientras que se está moviendo.
- ▲Siempre use dispositivos de seguridad mientras opera la cinta de correr.

IMPORTANT PRECAUTIONS

⚠ WARNING: To reduce the risk of serious injury, read all important precautions and instructions in this manual and all warnings on your treadmill before using your treadmill. ICON assumes no responsibility for personal injury or property damage sustained by or through the use of this product.

1. Before beginning this or any exercise program, consult your physician. This is especially important for persons over age 35 or persons with pre-existing health problems.
2. It is the responsibility of the owner to ensure that all users of this treadmill are adequately informed of all warnings and precautions.
3. Use the treadmill only as described.
4. Place the treadmill on a level surface, with at least 8 ft. (2.4 m) of clearance behind it and 2 ft. (0.6 m) on each side. Do not place the treadmill on any surface that blocks air openings. To protect the floor or carpet from damage, place a mat under the treadmill.
5. Keep the treadmill indoors, away from moisture and dust. Do not put the treadmill in a garage or covered patio, or near water.
6. Do not operate the treadmill where aerosol products are used or where oxygen is being administered.
7. Keep children under age 12 and pets away from the treadmill at all times.
8. The treadmill should not be used by persons weighing more than 250 lbs. (113 kg).
9. Never allow more than one person on the treadmill at a time.
10. Wear appropriate exercise clothes when using the treadmill. Do not wear loose clothes that could become caught in the treadmill. Athletic support clothes are recommended for both men and women. *Always wear athletic shoes; never use the treadmill with bare feet, wearing only stockings, or in sandals.*
11. When connecting the power cord (see page 10), plug the power cord into a surge suppressor (not included) and plug the surge suppressor into a grounded circuit capable of carrying 15 or more amps. No other appliance should be on the same circuit. Do not use an extension cord.
12. Use only a single-outlet surge suppressor that meets all of the specifications described on page 10. To purchase a surge suppressor, see your local WESLO dealer or call the telephone number on the front cover of this manual and order part number 146148, or see your local electronics store.
13. Failure to use a properly functioning surge suppressor could result in damage to the control system of the treadmill. If the control system is damaged, the walking belt may slow, accelerate, or stop unexpectedly, which may result in a fall and serious injury.
14. Keep the power cord and the surge suppressor away from heated surfaces.
15. Never move the walking belt while the power is turned off. Do not operate the treadmill if the power cord or plug is damaged, or if the treadmill is not working properly. (See TROUBLESHOOTING on page 16 if the treadmill is not working properly.)
16. Read, understand, and test the emergency stop procedure before using the treadmill (see HOW TO TURN ON THE POWER on page 12).
17. Never start the treadmill while you are standing on the walking belt. Always hold the handrails while using the treadmill.
18. The heart rate monitor is not a medical device. Various factors, including your movement, may affect the accuracy of heart rate readings. The heart rate monitor is intended only as an exercise aid in determining heart rate trends in general.
19. The treadmill is capable of high speeds. Adjust the speed in small increments to avoid sudden jumps in speed.

20. Never leave the treadmill unattended while it is running. Always remove the key, unplug the power cord, and press the power switch into the off position when the treadmill is not in use. (See the drawing on page 5 for the location of the power switch.)
21. Do not attempt to raise, lower, or move the treadmill until it is properly assembled. (See ASSEMBLY on page 6 and HOW TO FOLD AND MOVE THE TREADMILL on page 15.) You must be able to safely lift 45 lbs. (20 kg) to raise, lower, or move the treadmill.
22. When folding or moving the treadmill, make sure that the storage latch is holding the frame securely in the storage position.
23. Do not change the incline of the treadmill by placing objects under the treadmill.
24. Inspect and properly tighten all parts of the treadmill regularly.
25. Never drop or insert any object into any opening on the treadmill.
26. **DANGER:** Always unplug the power cord immediately after use, before cleaning the treadmill, and before performing the maintenance and adjustment procedures described in this manual. Never remove the motor hood unless instructed to do so by an authorized service representative. Servicing other than the procedures in this manual should be performed by an authorized service representative only.
27. This treadmill is intended for in-home use only. Do not use this treadmill in any commercial, rental, or institutional setting.
28. Over exercising may result in serious injury or death. If you feel faint or if you experience pain while exercising, stop immediately and cool down.

SAVE THESE INSTRUCTIONS

BEFORE YOU BEGIN

Thank you for selecting the new WESLO® CADENCE AF 5.1 treadmill. The CADENCE AF 5.1 treadmill offers a selection of features designed to make your workouts at home more effective. And when you're not exercising, the unique treadmill can be folded up, requiring less than half the floor space of other treadmills.

For your benefit, read this manual carefully before using the treadmill. If you have questions after read-

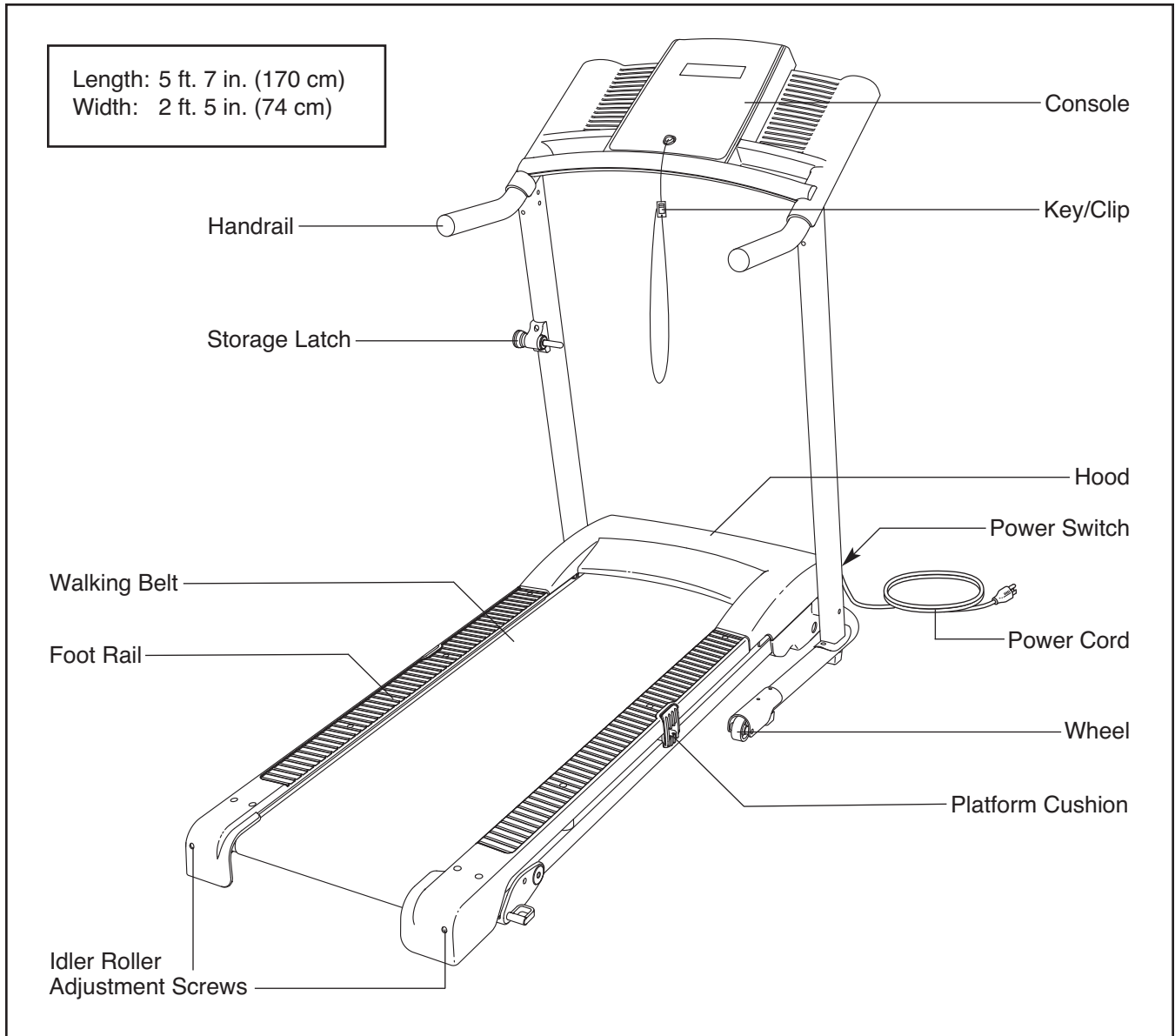

ing this manual, please see the front cover of this manual. To help us assist you, note the product model number and serial number before contacting us. The model number and the location of the serial number decal are shown on the front cover of this manual.

Before reading further, please review the drawing below and familiarize yourself with the labeled parts.



ASSEMBLY

To hire an authorized service technician to assemble the treadmill, call toll-free 1-800-445-2480. Assembly requires two persons. Set the treadmill in a cleared area and remove all packing materials. **Do not dispose of the packing materials until assembly is completed.** Note: The underside of the treadmill walking belt is coated with high-performance lubricant. During shipping, some lubricant may be transferred to the top of the walking belt or the shipping carton. This is normal and does not affect treadmill performance. If there is lubricant on top of the walking belt, simply wipe off the lubricant with a soft cloth and a mild, non-abrasive cleaner.

Assembly requires the included hex keys  and your own Phillips screwdriver , adjustable wrench , and needlenose pliers .

Use the drawings below to identify the assembly hardware. The number in parentheses below each drawing is the key number of the part, from the PART LIST near the end of this manual. The number after the parentheses is the quantity needed for assembly. **Note: Some small parts may have been pre-assembled. To avoid damaging parts, do not use power tools for assembly. Extra hardware may be included.**

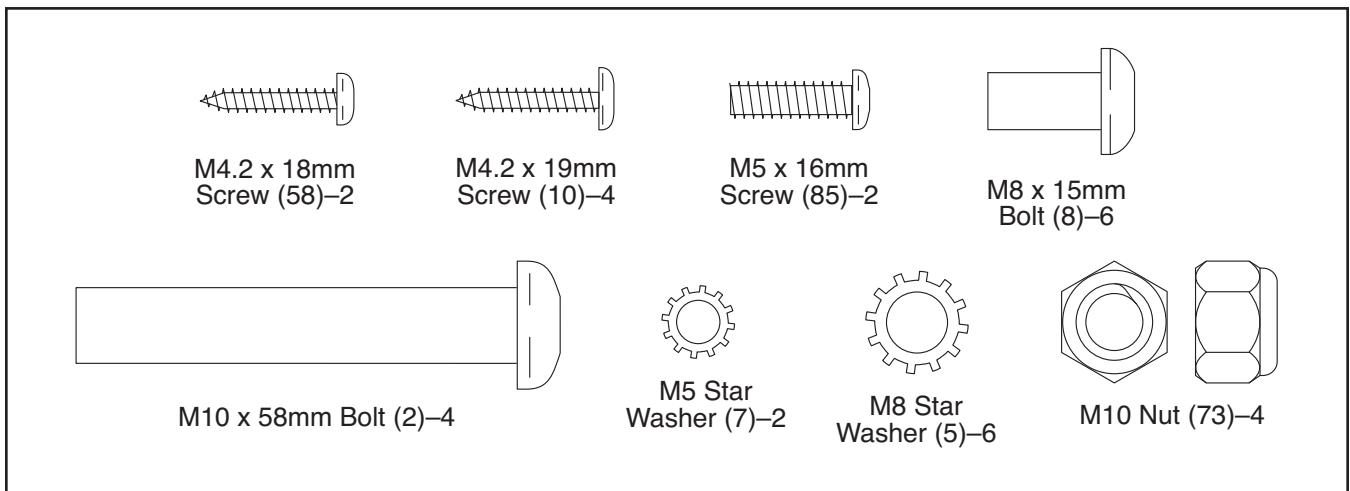

1. With the help of a second person, carefully tip the treadmill onto its side. Unfold the Frame (51) away from the Uprights (53, 54).

Orient the Base (52) as shown. Attach the Base to the Left Upright (53) and the Right Upright (54) with four M10 x 58mm Bolts (2) and four M10 Nuts (73). **Start all four Nuts, and then tighten them.**

With the help of a second person, carefully tip the treadmill so that the Base (52) is flat on the floor.

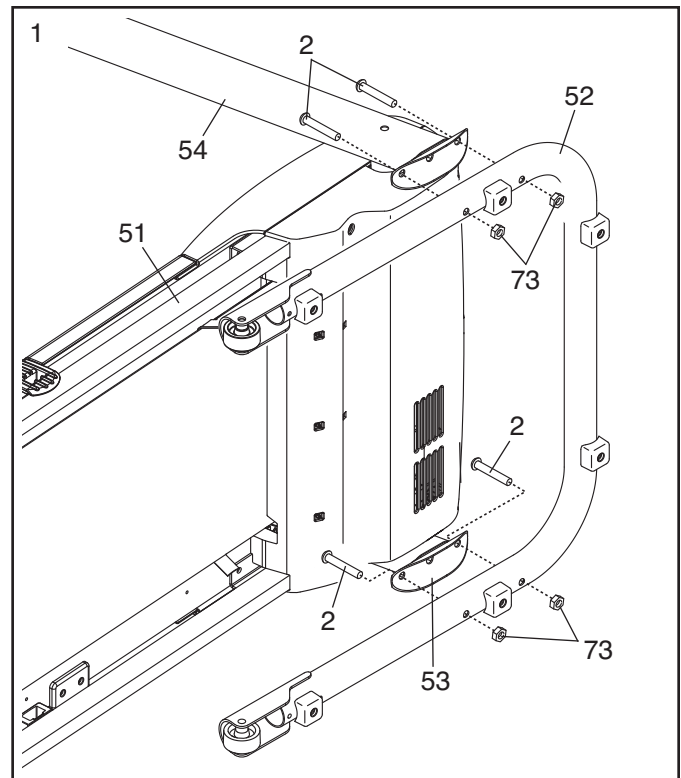

2. Set the console assembly face down on a soft surface to avoid scratching it.

Identify the Right Handrail (33), which has a large hole in the location shown. Hold the Right Handrail near the console assembly.

Next, insert the console wire into the large hole in the side of the Right Handrail (33). Using needlenose pliers, carefully grasp the connector and pull the console wire out of the hole near the bracket on the Right Handrail.

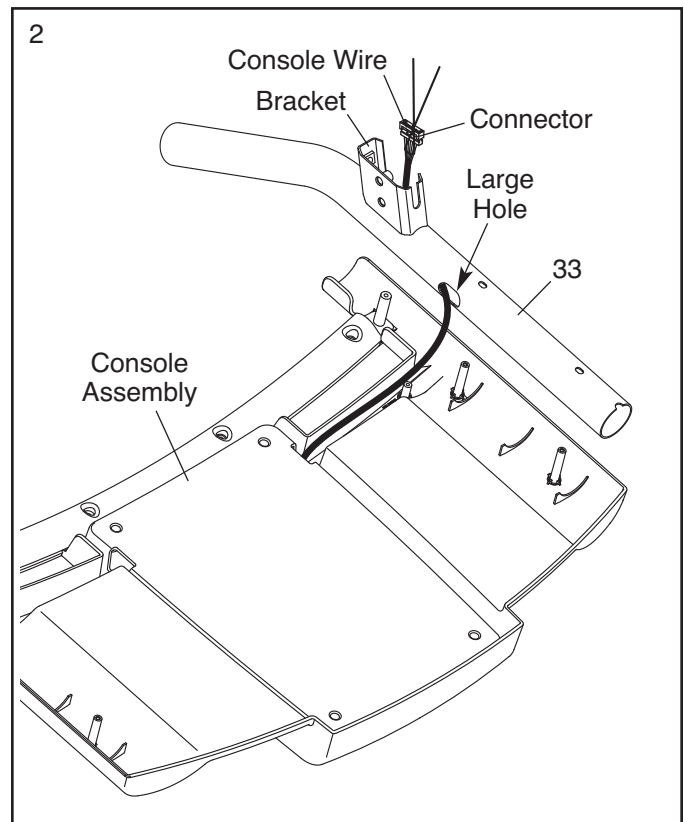

- Set the Right Handrail (33) on the console assembly. **Make sure that the console wire is not pinched.** Remove the tie from the bracket on the Right Handrail. If necessary, press the Cage Nuts (101) back into place.

Start an M5 x 16mm Screw (85) with an M5 Star Washer (7) into the Right Handrail, and then start two M4.2 x 19mm Screws (10) into the Right Handrail. **Tighten the M5 x 16mm Screw and then tighten the two M4.2 x 19mm Screws; do not overtighten the Screws.**

Attach the Left Handrail (not shown) to the console assembly in the same way. Note: There is no wire on the left side.

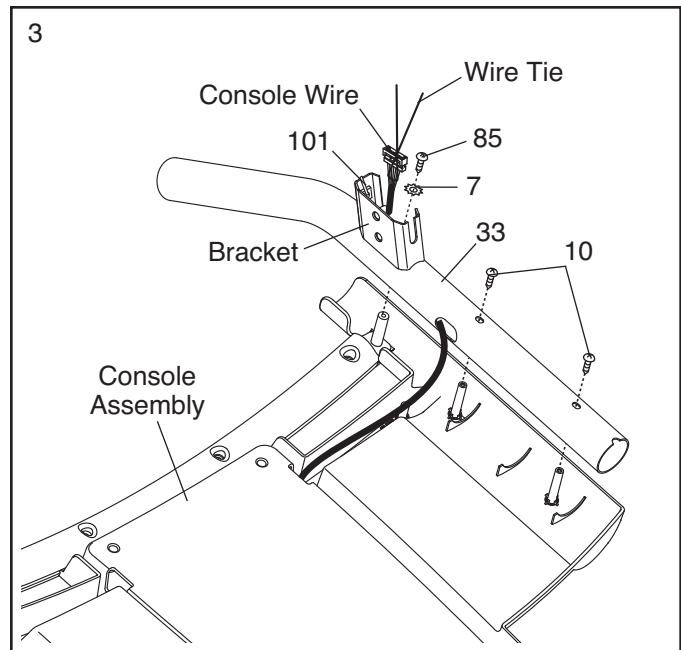

- With the help of a second person, hold the console assembly near the Right Upright (54).

Connect the Wire Harness (39) to the console wire. **See the inset drawing. The connectors should slide together easily and snap into place.** If they do not, turn one connector and try again. **IF YOU DO NOT CONNECT THE CONNECTORS PROPERLY, THE CONSOLE MAY BECOME DAMAGED WHEN YOU TURN ON THE POWER.** If there is a wire tie on the Wire Harness, remove the wire tie. Then, insert the connectors and the excess wire downward into the Right Upright (54).

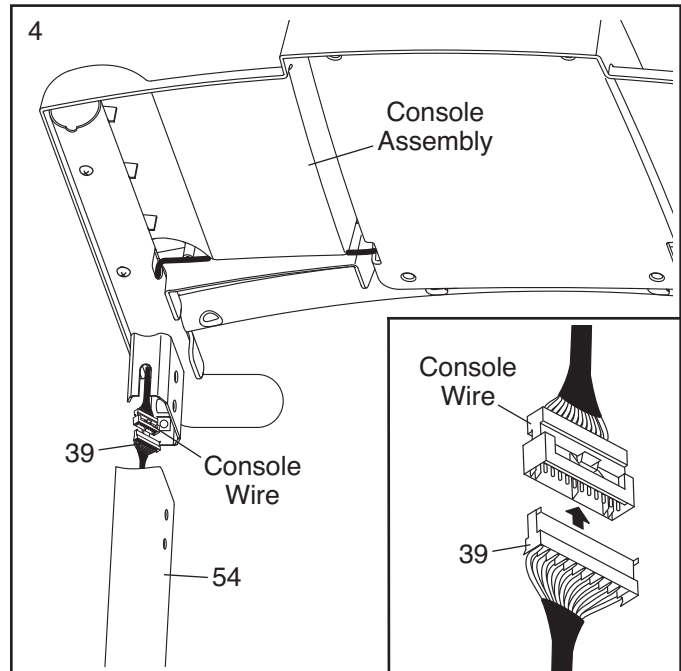

- Set the console assembly on the Uprights (53, 54). **Make sure that no wires are pinched.** Start four M8 x 15mm Bolts (8) with four M8 Star Washers (5) into the Uprights as shown. **Do not tighten the Bolts yet.**

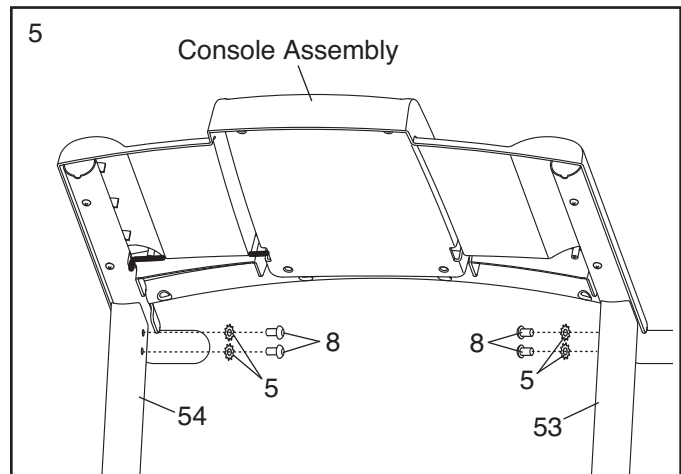

6. Start an M8 x 15mm Bolt (8) with an M8 Star Washer (5) into each Upright (53, 54). **Then, firmly tighten all six M8 x 15mm Bolts (8).**

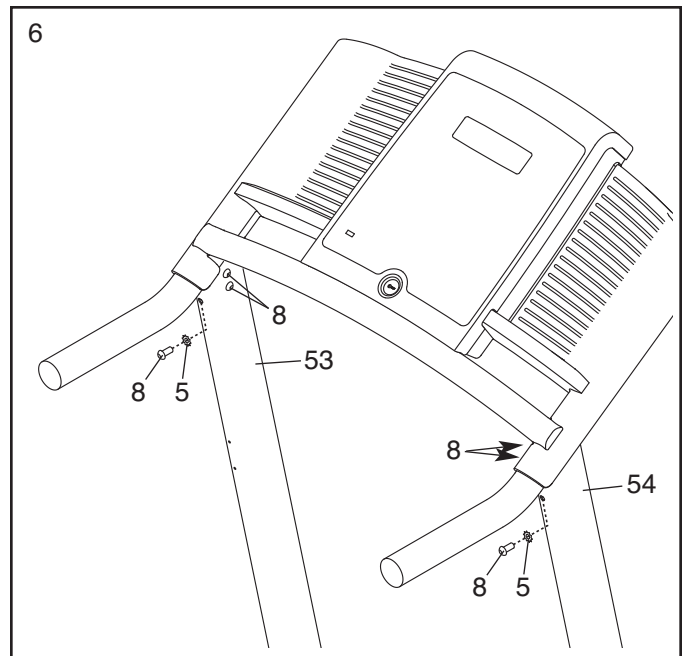

7. Attach the Latch Housing (48) to the Left Upright (53) with two M4.2 x 18mm Screws (58); **start both Screws, and then tighten them.**

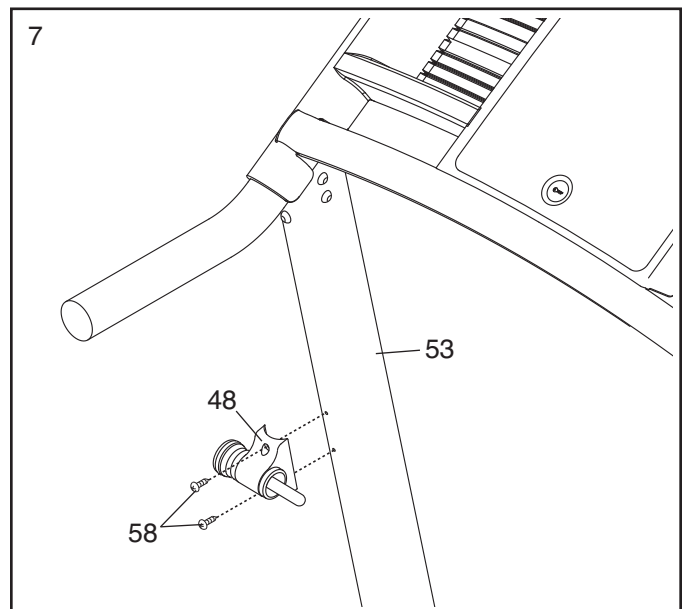

8. **Make sure that all parts are properly tightened before you use the treadmill.** Keep the included hex keys in a secure place. One of the hex keys is used to adjust the walking belt (see page 17). To protect the floor or carpet, place a mat under the treadmill.

OPERATION AND ADJUSTMENT

THE PRE-LUBRICATED WALKING BELT

Your treadmill features a walking belt coated with high-performance lubricant. **IMPORTANT: Never apply silicone spray or other substances to the walking belt or the walking platform. Such substances will cause excessive wear.**

HOW TO PLUG IN THE POWER CORD

⚠ DANGER: Improper connection of the equipment-grounding conductor increases the risk of electric shock. Check with a qualified electrician or serviceman if you are unsure whether the product is properly grounded. Do not modify the plug—if it will not fit the outlet, have a proper outlet installed by a qualified electrician.

Your treadmill, like other electronic equipment, can be damaged by sudden voltage changes in your home's power. **To decrease the risk of damaging your treadmill, always use a surge suppressor with your treadmill (see drawing 1 at the right). To purchase a surge suppressor, see precaution 12 on page 3.**

Use only a single-outlet surge suppressor that is UL 1449 listed as a transient voltage surge suppressor (TVSS). The surge suppressor must have a UL suppressed voltage rating of 400 volts or less and a minimum surge dissipation of 450 joules. The surge suppressor must be electrically rated for 120 volts AC and 15 amps. There must be a monitoring light on the surge suppressor to indicate whether it is functioning properly. Failure to use a properly functioning surge suppressor could damage the control system of the treadmill (see precaution 13 on page 3).

This product must be grounded. If it should malfunction or break down, grounding provides a path of least resistance for electric current to reduce the risk of electric shock. This product's power cord has an equipment-grounding conductor and a grounding plug. **Plug the power cord into a surge suppressor, and plug the surge suppressor into an appropriate outlet that is properly installed and grounded in accor-**

dance with all local codes and ordinances.

IMPORTANT: The treadmill is not compatible with GFCI-equipped outlets and may not be compatible with AFCI-equipped outlets.

This product is for use on a nominal 120-volt circuit (see drawing 1). A temporary adapter may be used to connect the surge suppressor to a 2-pole receptacle if a properly grounded outlet is not available (see drawing 2).

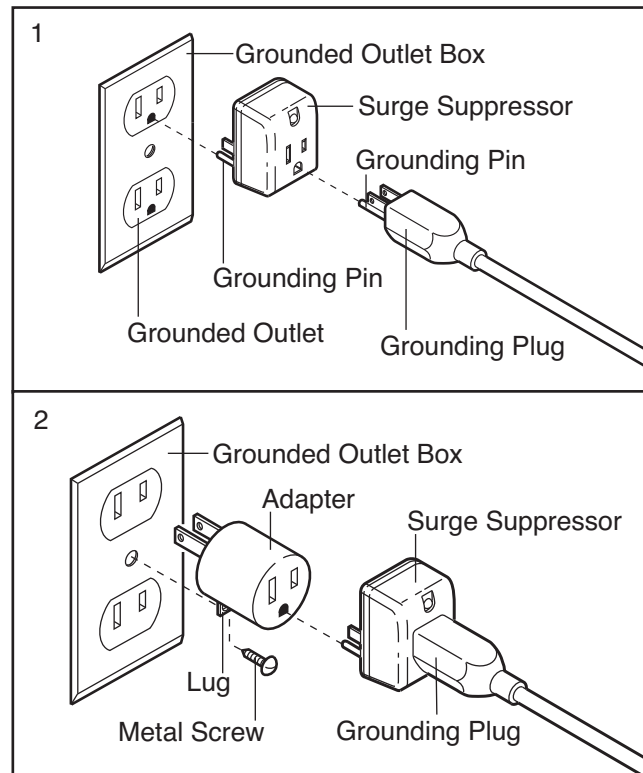

The temporary adapter should be used only until a properly grounded outlet (see drawing 1) can be installed by a qualified electrician.

The green-colored rigid ear, lug, or the like extending from the adapter must be connected to a permanent ground such as a properly grounded outlet box cover. The adapter must be held in place by a metal screw. **Some 2-pole receptacle outlet box covers are not grounded. Contact a qualified electrician to determine if the outlet box cover is grounded before using an adapter.**

CONSOLE DIAGRAM

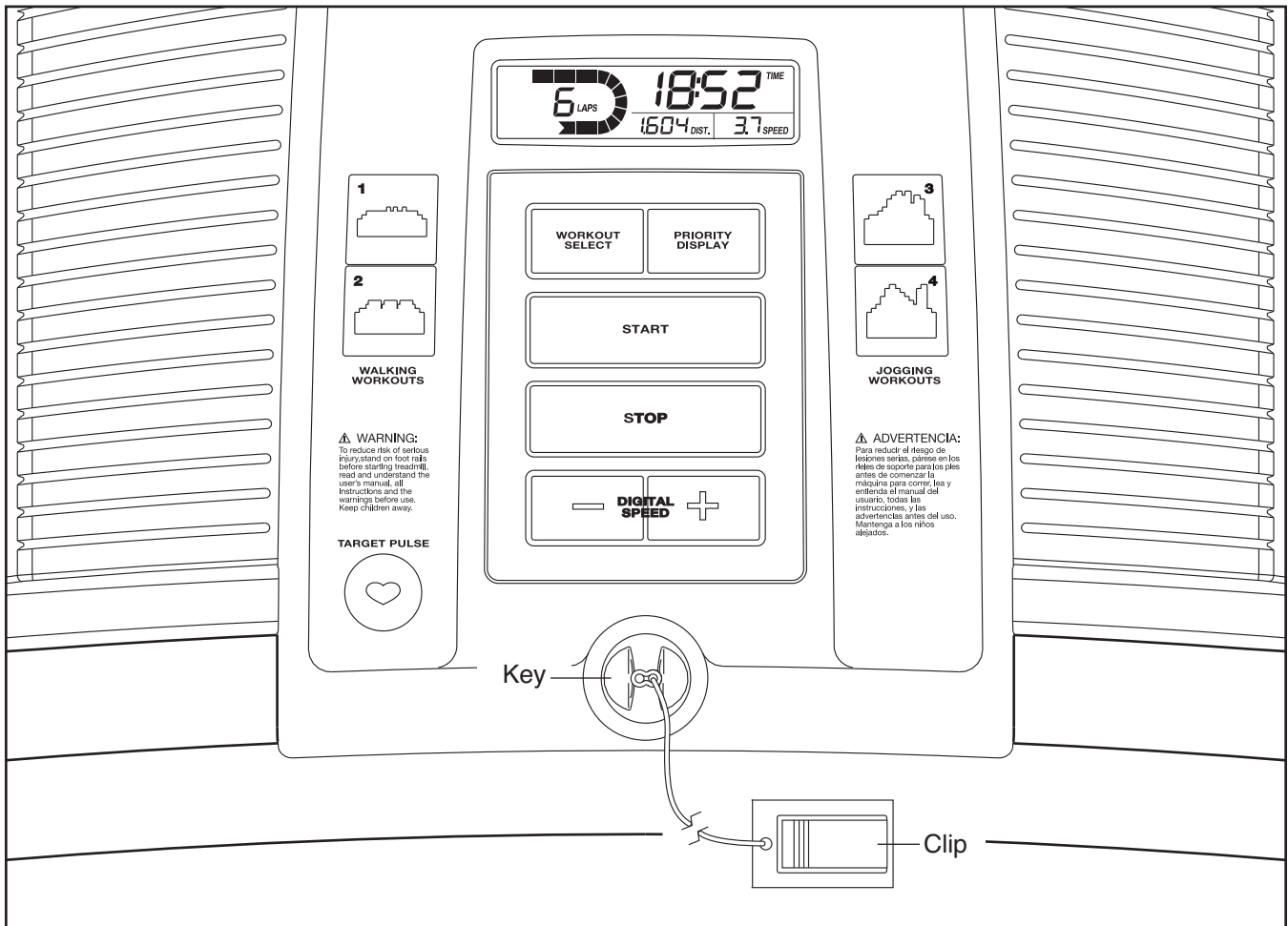

FEATURES OF THE CONSOLE

The treadmill console offers a selection of features designed to make your workouts more effective. When the manual mode of the console is selected, the speed of the treadmill can be changed with the touch of a button. As you exercise, the displays will provide continuous exercise feedback. You can even measure your heart rate using the thumb heart rate monitor.

The console also offers four preset workouts. Each workout automatically controls the speed of the treadmill as it guides you through an effective exercise session.

To turn on the power, see page 12. **To use the manual mode**, see page 12. **To use a preset workout**, see page 13. **To change the incline of the treadmill**, see page 14.

IMPORTANT: If there is a sheet of plastic on the console, remove the plastic. To prevent damage to the walking platform, wear clean athletic shoes while using the treadmill. The first time the treadmill is used, observe the alignment of the walking belt, and center the walking belt if necessary (see page 17).

HOW TO TURN ON THE POWER

IMPORTANT: If the treadmill has been exposed to cold temperatures, allow it to warm to room temperature before you turn on the power. If you do not do this, you may damage the console displays or other electrical components.

Plug in the power cord (see page 10). Next, locate the power switch on the treadmill frame near the power cord. Make sure that the switch is in the reset position.

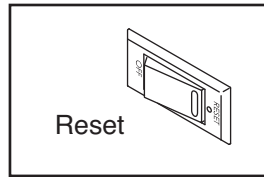

Next, stand on the foot rails of the treadmill. Locate the clip attached to the key (see the drawing on page 11), and slide the clip securely onto the waistband of your clothes. Then, insert the key into the console. After a moment, the displays will light. **IMPORTANT:** In an emergency, the key can be pulled from the console, causing the walking belt to slow to a stop. Test the clip by carefully taking a few steps backward; if the key is not pulled from the console, adjust the position of the clip.

HOW TO USE THE MANUAL MODE

1. Insert the key into the console.

See HOW TO TURN ON THE POWER above.

2. Select the manual mode.

When the key is inserted, the manual mode will be selected. If you have selected a preset workout, reselect the manual mode by pressing the Workout Select button repeatedly until only zeros appear in the displays.



3. Start the walking belt.

To start the walking belt, press the Start button or the Speed increase button. The walking belt will begin to move at 1 mph. As you exercise, change the speed of the walking belt as desired by pressing the Speed increase and decrease buttons. Each time you press one of the buttons, the speed setting will change by 0.1 mph; if you hold down the button, the speed setting will change by 0.5 mph. Note: After you press the buttons, it may take a moment for the walking belt to reach the selected speed setting.

To stop the walking belt, press the Stop button. The time will begin to flash in the display. To restart the walking belt, press the Start button or the Speed increase button.

4. Follow your progress with the displays.

The track—The track represents a distance of 1/4 mile (400 meters). As you walk or run on the treadmill, the indicators around the track will appear in succession until the entire track appears. The track will then disappear and the indicators will again begin to appear in succession. The center of the track will show the number of laps that you have completed.

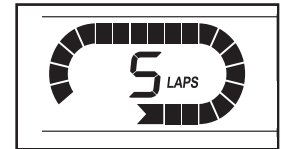

The lower left display—As you exercise, the lower left display can show the elapsed time and the distance that you have walked or run. Note: When a preset workout is selected, the lower left corner of the display will show the time remaining in the workout instead of the elapsed time.



The lower right display—The lower right display can show the speed of the walking belt and the approximate number of calories that you have burned.



The priority display—

The upper display is the priority display. The priority display can show the elapsed time, the distance that you have walked or run, the speed of the walking belt, or the approximate number of calories you have burned. Press the Priority Display button repeatedly until the priority display shows the information that you are most interested in viewing. Note: While information is shown in the priority display, the same information will not be shown in the lower left or right display.



To reset the displays, press the Stop button, remove the key, and then reinsert the key.

Note: The console can display speed and distance in either miles or kilometers. To see which unit of measurement is selected, hold down the Stop button, insert the key into the console, and then release the Stop button. An M for metric kilometers or an E for English miles will appear in the priority display. Press the Speed increase button to change the unit of measurement. When the desired unit of measurement is selected, remove the key and then reinsert it.

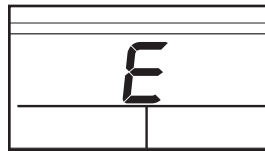

5. Measure your heart rate if desired.

To measure your heart rate, **stand on the foot rails** and place your thumb on the heart rate monitor (see the drawing on page 11). **Do not press too hard, or the circulation in your thumb will be restricted and your pulse may not be detected.** When your pulse is detected, a heart-shaped indicator in the lower right display will flash each time your heart beats, one or two dashes will appear, and then your heart rate will be shown. **For the most accurate heart rate reading, hold your thumb on the heart rate monitor for at least 15 seconds.**

If the displayed heart rate appears to be too high or too low, or if your heart rate is not displayed, lift your thumb for a few seconds, and then reposition your thumb on the heart rate monitor. Remember to stand still while measuring your heart rate.

6. When you are finished exercising, remove the key from the console.

Step onto the foot rails, press the Stop button, remove the key from the console, and put it in a secure place. When you are finished using the treadmill, press the power switch into the off position and unplug the power cord. **IMPORTANT: If you do not do this, the treadmill's electrical components may wear prematurely.**

HOW TO USE A PRESET WORKOUT

1. Insert the key into the console.

See HOW TO TURN ON THE POWER on page 12.

2. Select one of the four preset workouts.

To select a preset workout, press the Workout Select button repeatedly; "P- 1," "P- 2," "P- 3," or "P- 4" will appear in the priority display for a few seconds to show which workout is selected. The maximum speed of the workout and the duration of the workout will also appear in the display for a few seconds.

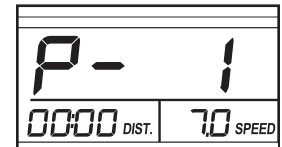

Each workout consists of 30 one-minute segments. One speed setting is programmed for each segment. Note: The same speed setting may be programmed for consecutive segments. The profiles on the console show how the speed of the walking belt will change during the workouts.

3. Start the walking belt.

Press the Start button or the Speed increase button to start the workout. When you press the button, the treadmill will automatically adjust to the speed setting that is programmed for the first segment. Hold the handrails and begin walking.

At the end of each segment, a series of tones will sound. If a different speed setting is programmed for the next segment, the speed setting will flash in the display to alert you and the treadmill will automatically adjust to the new speed setting. The workout will continue in this way until the last segment ends. The walking belt will then slow to a stop.

If the speed setting is too high or too low during the workout, you can manually override the setting by pressing the Speed buttons; **however, when the current segment of the workout ends, the treadmill will automatically adjust to the speed setting for the next segment.**

To stop the workout temporarily, press the Stop button. The time will begin to flash in the display. To restart the workout, press the Start button or the Speed increase button. The walking belt will begin to move at 1 mph. When the next segment begins, the treadmill will automatically adjust to the speed setting programmed for the next segment.

4. Follow your progress with the displays.

See step 4 on pages 12 and 13.

5. Measure your heart rate if desired.

See step 5 on page 13.

6. When you are finished exercising, remove the key from the console.

See step 6 on page 13.

HOW TO CHANGE THE INCLINE OF THE TREADMILL

To vary the intensity of your exercise, you can change the incline of the treadmill. There are two incline levels. **Before changing the incline, remove the key and unplug the power cord.** Next, fold the treadmill to the storage position (see page 15).

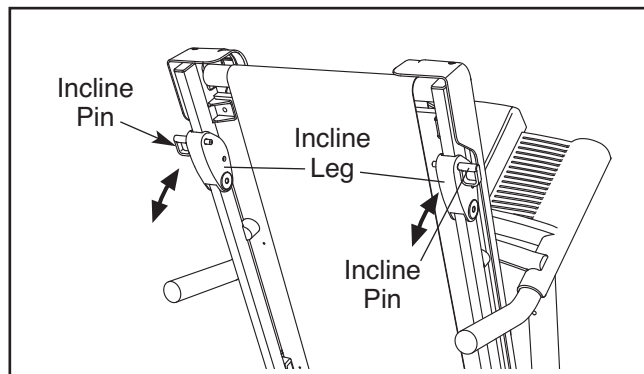

To change the incline, first remove the incline pin from one of the incline legs. Adjust the incline leg to the desired position, and then fully reinsert the incline pin. Adjust the other incline leg in the same way.

CAUTION: Before using the treadmill, make sure that both incline legs are at the same height and that both incline pins are fully inserted into the incline legs.

After you have adjusted the incline legs, lower the treadmill (see page 15).

HOW TO FOLD AND MOVE THE TREADMILL

HOW TO FOLD THE TREADMILL

Remove the key and unplug the power cord.

CAUTION: You must be able to safely lift 45 lbs. (20 kg) to raise, lower, or move the treadmill.

1. Hold the metal frame firmly in the location shown by the arrow below. **CAUTION: Do not hold the frame by the plastic foot rails. Bend your legs and keep your back straight.** Raise the frame about halfway to the vertical position.

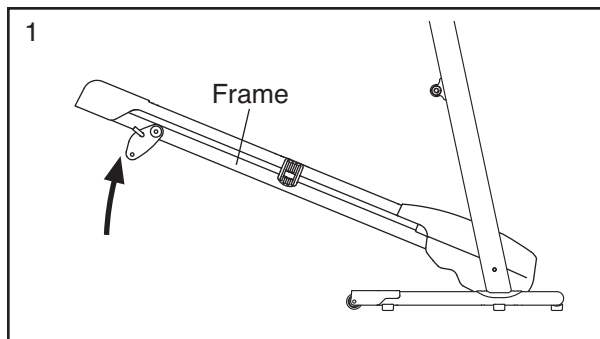

2. Hold the treadmill firmly with your right hand as shown. Pull the latch knob to the left and hold it. Raise the frame until the catch is past the latch pin. Then, slowly release the latch knob; **make sure that the catch is resting against the latch pin.**

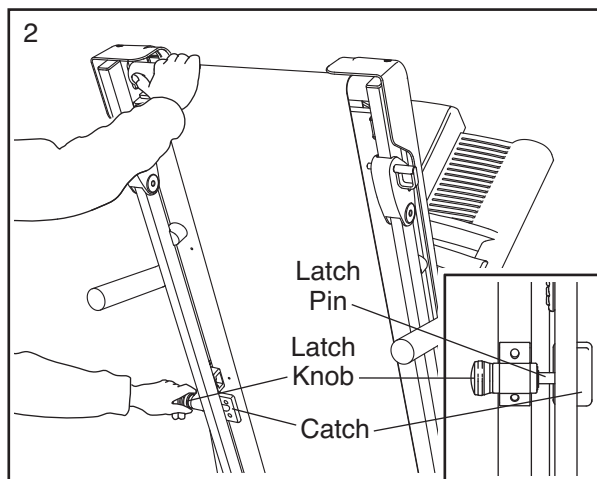

To protect the floor or carpet, place a mat under the treadmill. Keep the treadmill out of direct sunlight. Do not leave the treadmill in the storage position in temperatures above 85° F (30° C).

HOW TO MOVE THE TREADMILL

Before moving the treadmill, fold it as described at the left. **CAUTION: Make sure that the catch is resting against the latch pin. Moving the treadmill may require two people.**

1. Hold the frame and one of the handrails, and place one foot against a wheel.

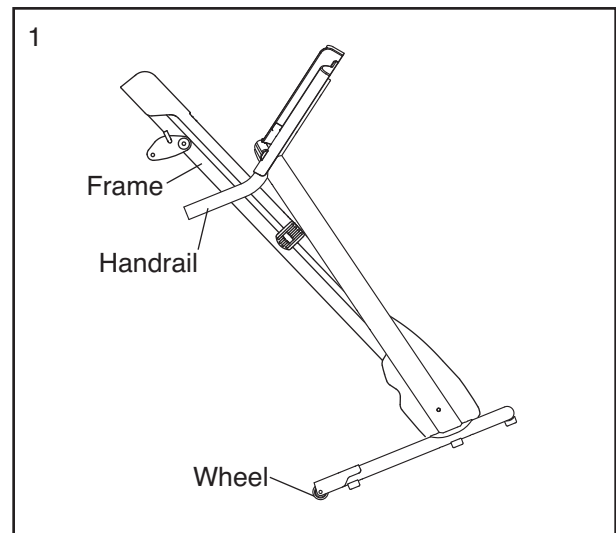

2. Pull back on the handrail until the treadmill will roll on the wheels, and carefully move it to the desired location. **CAUTION: Do not move the treadmill without tipping it back, do not pull on the frame, and do not move the treadmill over an uneven surface.**
3. Place one foot against a wheel, and carefully lower the treadmill.

HOW TO LOWER THE TREADMILL FOR USE

1. **See drawing 2.** Hold the upper end of the treadmill with your right hand as shown. Then, pull the latch knob to the left and hold it. **IMPORTANT: Do not turn the latch knob.** Next, lower the frame until it is past the latch pin. Then, release the latch knob.
2. **See drawing 1 at the left.** Hold the metal frame firmly with both hands, and lower it to the floor. **CAUTION: Do not hold the frame by the plastic foot rails, and do not drop the frame. Bend your legs and keep your back straight.**

TROUBLESHOOTING

Most treadmill problems can be solved by following the simple steps below. Find the symptom that applies, and follow the steps listed. If further assistance is needed, see the front cover of this manual.

SYMPTOM: The power does not turn on

- Make sure that the power cord is plugged into a surge suppressor and that the surge suppressor is plugged into a properly grounded outlet (see page 10). Use only a single-outlet surge suppressor that meets all of the specifications described on page 10. **IMPORTANT: The treadmill is not compatible with GFCI-equipped outlets and may not be compatible with AFCI-equipped outlets.**
- After the power cord has been plugged in, make sure that the key is inserted into the console.
- Check the power switch located on the treadmill frame near the power cord. If the switch protrudes as shown, the switch has tripped. To reset the power switch, wait for five minutes and then press the switch back in.

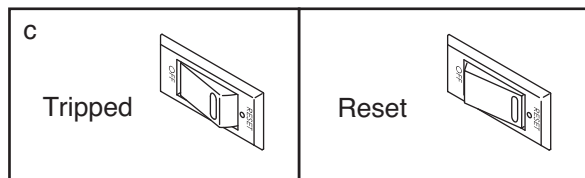

SYMPTOM: The power turns off during use

- Check the power switch (see the drawing above). If the switch has tripped, wait for five minutes and then press the switch back in.
- Make sure that the power cord is plugged in. If the power cord is plugged in, unplug it, wait for five minutes, and then plug it back in.
- Remove the key from the console, and then reinsert it.
- If the treadmill still will not run, please see the front cover of this manual.

SYMPTOM: The displays of the console do not function properly

- Remove the key from the console and **UNPLUG THE POWER CORD**. Next, remove the three M4.2 x 19mm Washer Head Screws (20) and the two indicated M5.5 x 25mm Screws (25). Then, carefully remove the Hood (65).

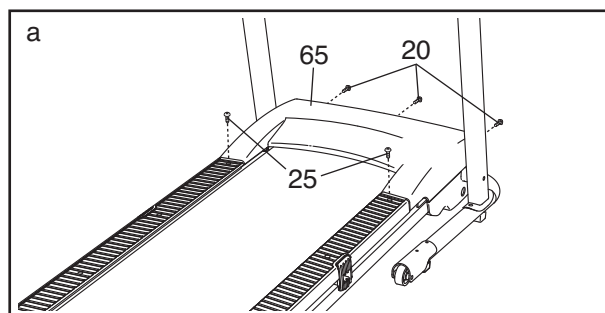

Locate the Reed Switch (89) and the Magnet (62) on the left side of the Pulley (71). Turn the Pulley until the Magnet is aligned with the Reed Switch. **Make sure that the gap between the Magnet and the Reed Switch is about 1/8 in. (3 mm).** If necessary, loosen the M4.2 x 13mm Tek Screw (3), move the Reed Switch slightly, and then retighten the Screw. Then, reattach the Hood (not shown), and run the treadmill for a few minutes to check for a correct speed reading.

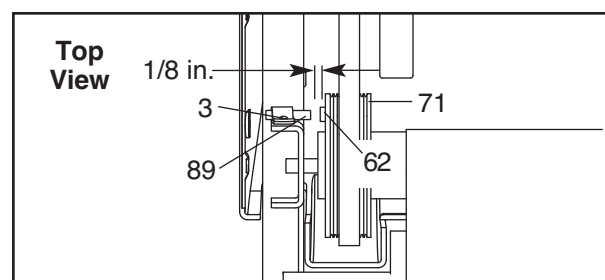

SYMPTOM: The walking belt slows when walked on

- a. Use only a single-outlet surge suppressor that meets all of the specifications described on page 10.
- b. If the walking belt is overtightened, treadmill performance may decrease and the walking belt may become damaged. Remove the key and **UNPLUG THE POWER CORD**. Using the hex key, turn both idler roller screws counterclockwise, 1/4 of a turn. When the walking belt is properly tightened, you should be able to lift each edge of the walking belt 2 to 3 in. (5 to 7 cm) off the walking platform. Be careful to keep the walking belt centered. Then, plug in the power cord, insert the key, and run the treadmill for a few minutes. Repeat until the walking belt is properly tightened.

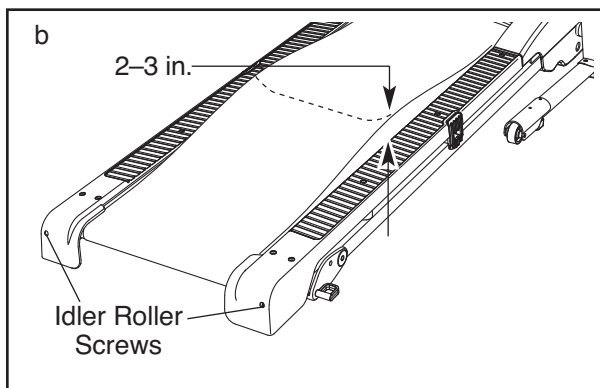

- c. If the walking belt still slows when walked on, see the front cover of this manual.

SYMPTOM: The walking belt is off-center or slips when walked on

- a. **If the walking belt is off-center**, first remove the key and **UNPLUG THE POWER CORD**. **If the walking belt has shifted to the left**, use the hex key to turn the left idler roller screw clockwise 1/2

of a turn; **if the walking belt has shifted to the right**, turn the left idler roller screw counterclockwise 1/2 of a turn. Be careful not to overtighten the walking belt. Then, plug in the power cord, insert the key, and run the treadmill for a few minutes. Repeat until the walking belt is centered.

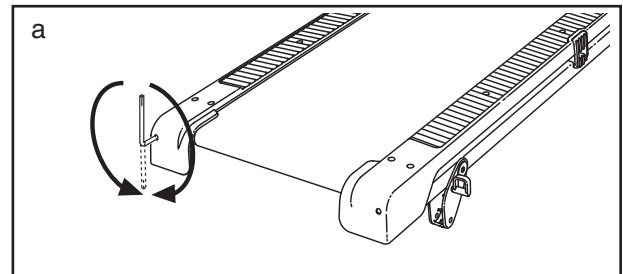

- b. **If the walking belt slips when walked on**, first remove the key and **UNPLUG THE POWER CORD**. Using the hex key, turn both idler roller screws clockwise, 1/4 of a turn. When the walking belt is correctly tightened, you should be able to lift each edge of the walking belt 2 to 3 in. (5 to 7 cm) off the walking platform. Be careful to keep the walking belt centered. Then, plug in the power cord, insert the key, and carefully walk on the treadmill for a few minutes. Repeat until the walking belt is properly tightened.

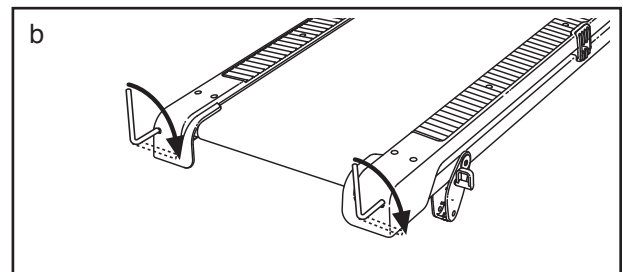

EXERCISE GUIDELINES

⚠ WARNING: Before beginning any exercise program, consult your physician. This is especially important for persons over age 35 or persons with pre-existing health problems.

The heart rate monitor is not a medical device. Various factors may affect the accuracy of heart rate readings. The heart rate monitor is intended only as an exercise aid in determining heart rate trends in general.

These guidelines will help you to plan your exercise program. For detailed exercise information, obtain a reputable book or consult your physician. Remember, proper nutrition and adequate rest are essential for successful results.

EXERCISE INTENSITY

Whether your goal is to burn fat or to strengthen your cardiovascular system, exercising at the proper intensity is the key to achieving results. You can use your heart rate as a guide to find the proper intensity level. The chart below shows recommended heart rates for fat burning and aerobic exercise.

165	155	145	140	130	125	115	♥♥
145	138	130	125	118	110	103	♥
125	120	115	110	105	95	90	♥
<hr/>							
20	30	40	50	60	70	80	

To find the proper intensity level, find your age at the bottom of the chart (ages are rounded off to the nearest ten years). The three numbers listed above your age define your “training zone.” The lowest number is the heart rate for fat burning, the middle number is the heart rate for maximum fat burning, and the highest number is the heart rate for aerobic exercise.

Burning Fat—To burn fat effectively, you must exercise at a low intensity level for a sustained period of time. During the first few minutes of exercise, your body uses *carbohydrate calories* for energy. Only after the first few minutes of exercise does your body begin to use stored *fat calories* for energy. If your goal is to burn fat, adjust the intensity of your exercise until your heart rate is near the lowest number in your training zone. For maximum fat burning, exercise with your heart rate near the middle number in your training zone.

Aerobic Exercise—If your goal is to strengthen your cardiovascular system, you must perform aerobic exercise, which is activity that requires large amounts of oxygen for prolonged periods of time. For aerobic exercise, adjust the intensity of your exercise until your heart rate is near the highest number in your training zone.

WORKOUT GUIDELINES

Warming Up—Start with 5 to 10 minutes of stretching and light exercise. A warm-up increases your body temperature, heart rate, and circulation in preparation for exercise.

Training Zone Exercise—Exercise for 20 to 30 minutes with your heart rate in your training zone. (During the first few weeks of your exercise program, do not keep your heart rate in your training zone for longer than 20 minutes.) Breathe regularly and deeply as you exercise—never hold your breath.

Cooling Down—Finish with 5 to 10 minutes of stretching. Stretching increases the flexibility of your muscles and helps to prevent post-exercise problems.

EXERCISE FREQUENCY

To maintain or improve your condition, complete three workouts each week, with at least one day of rest between workouts. After a few months of regular exercise, you may complete up to five workouts each week, if desired. Remember, the key to success is to make exercise a regular and enjoyable part of your everyday life.

PART LIST

Model No. WLTL29911.0 R0511A

Key No.	Qty.	Description	Key No.	Qty.	Description
1	2	M10 x 110mm Bolt	52	1	Base
2	4	M10 x 58mm Bolt	53	1	Left Upright
3	2	M4.2 x 13mm Tek Screw	54	1	Right Upright
4	9	M4.2 x 16mm Screw	55	1	Idler Roller
5	6	M8 Star Washer	56	1	Motor Belt
6	1	Warning Decal	57	1	Electronics Bracket
7	2	M5 Star Washer	58	2	M4.2 x 18mm Screw
8	6	M8 x 15mm Bolt	59	1	Motor Bracket
9	2	M10 Star Washer	60	1	Left Idler Roller Bracket
10	10	M4.2 x 19mm Screw	61	1	Right Idler Roller Bracket
11	2	Frame Spacer	62	1	Magnet
12	1	Console Base	63	6	Base Pad
13	4	M6 x 58mm Bolt	64	1	Catch
14	2	M10 Flat Washer	65	1	Hood
15	1	Key/Clip	66	1	Belly Pan
16	2	M10 Nut	67	1	Left Foot Rail
17	1	6mm Hex Key	68	1	Right Foot Rail
18	1	4mm Hex Key	69	4	Wheel Spacer
19	4	M8 x 30mm Bolt	70	2	Wheel
20	3	M4.2 x 19mm Washer Head Screw	71	1	Drive Roller/Pulley
21	6	M4.2 x 13mm Screw	72	4	M8 Flat Washer
22	1	Left Handrail	73	4	M10 Nut
23	1	Upright Grommet	74	2	Frame Endcap
24	1	Latch Pin Assembly	75	4	M5.5 x 30mm Screw
25	6	M5.5 x 25mm Screw	76	1	Walking Belt
26	6	M4.2 x 19mm Tek Screw	77	4	Handrail Endcap
27	2	M8 x 35mm Bolt	78	2	Platform Cushion
28	4	M4.2 x 13mm Guide Screw	79	1	Drive Motor
29	2	M6 x 70mm Screw	80	3	Wire Tie
30	2	1/4" Motor Screw	81	4	8" Tie
31	1	M8 x 102mm Bolt	82	2	M8 x 52mm Bolt
32	4	M6 Flat Washer	83	1	Reed Switch Clip
33	1	Right Handrail	84	2	M4 x 10mm Screw
34	2	M8 x 20mm Bolt	85	2	M5 x 16mm Screw
35	2	M10 x 65mm Bolt	86	1	Walking Platform
36	2	M6 Star Washer	87	1	Controller
37	1	Power Switch	88	1	Console Crossbar
38	2	Motor Star Washer	89	1	Reed Switch
39	1	Wire Harness	90	1	Power Cord
40	2	Incline Pin	91	1	Console
41	4	M4.2 x 13mm Washer Head Screw	92	1	Releasable Tie
42	4	Electronics Star Washer	93	2	Belt Guide
43	4	M6 Nut	94	1	5mm Hex Key
44	6	Motor Tension Nut/Platform Nut	95	2	Incline Leg
45	2	Wheel Housing	96	2	U-nut
46	2	M8 Nut	97	2	Drive Roller Washer
47	3	Hood Clip	98	2	Rear Cushion
48	1	Latch Housing	99	1	Power Cord Grommet
49	1	Belly Pan Grommet	100	1	M8 Nut
50	2	Cushion Fastener	101	2	Cage Nut
51	1	Frame	*	-	User's Manual

Note: Specifications are subject to change without notice. For information about ordering replacement parts, see the back cover of this manual. *These parts are not illustrated.

EXPLODED DRAWING A

Model No. WLTL29911.0 R0511A

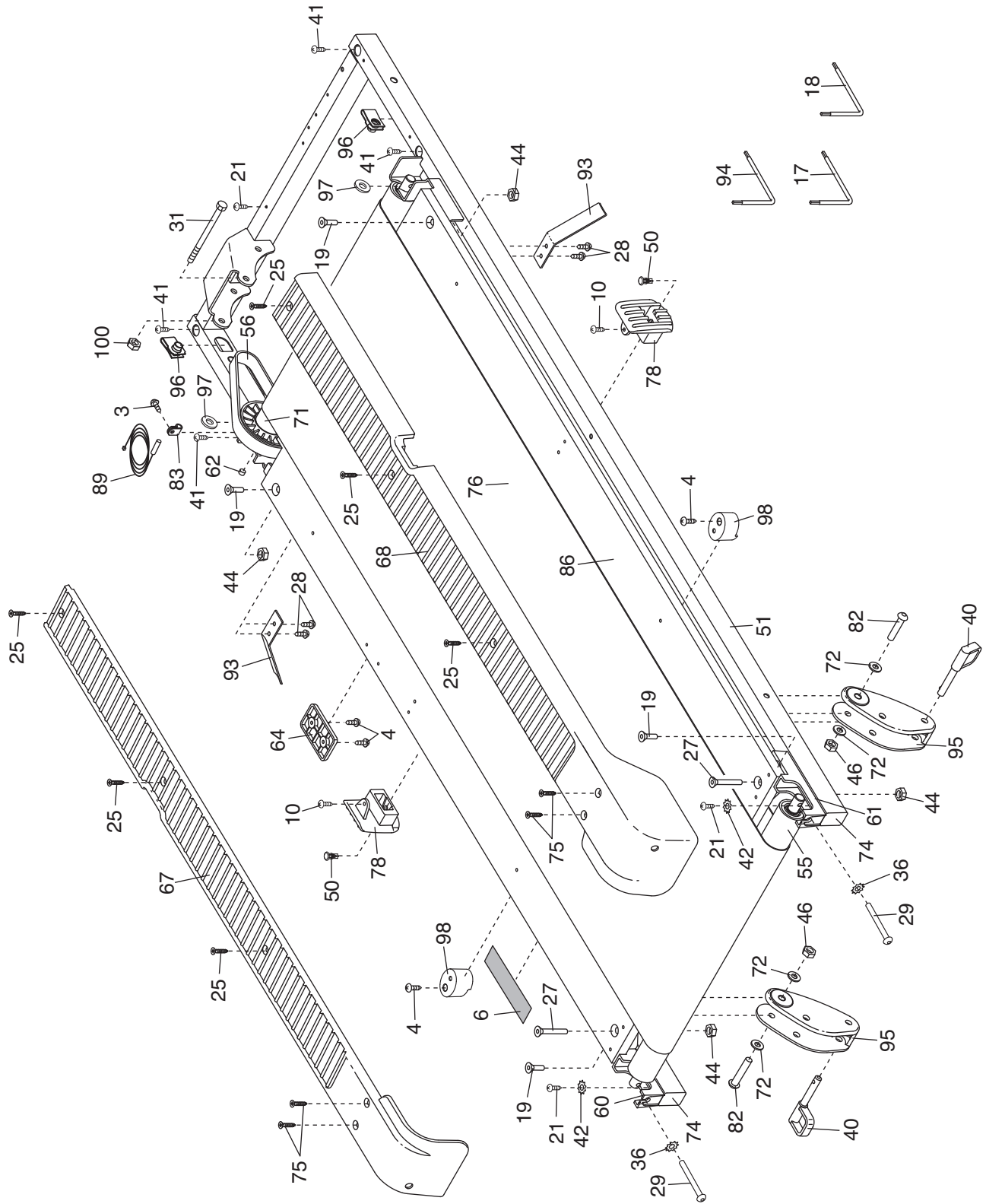

EXPLODED DRAWING B

Model No. WLTL29911.0 R0511A

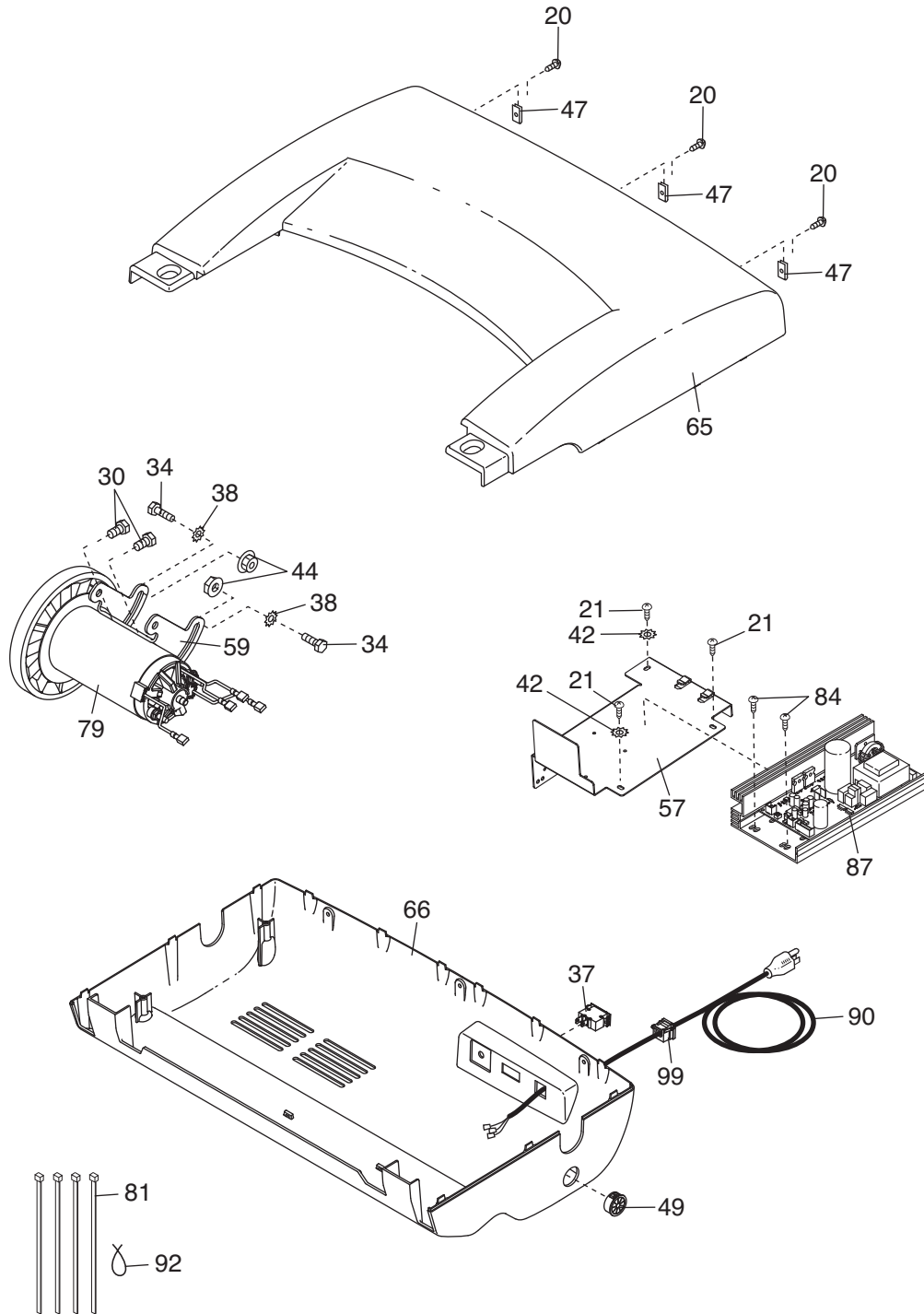

EXPLODED DRAWING C

Model No. WLTL29911.0 R0511A

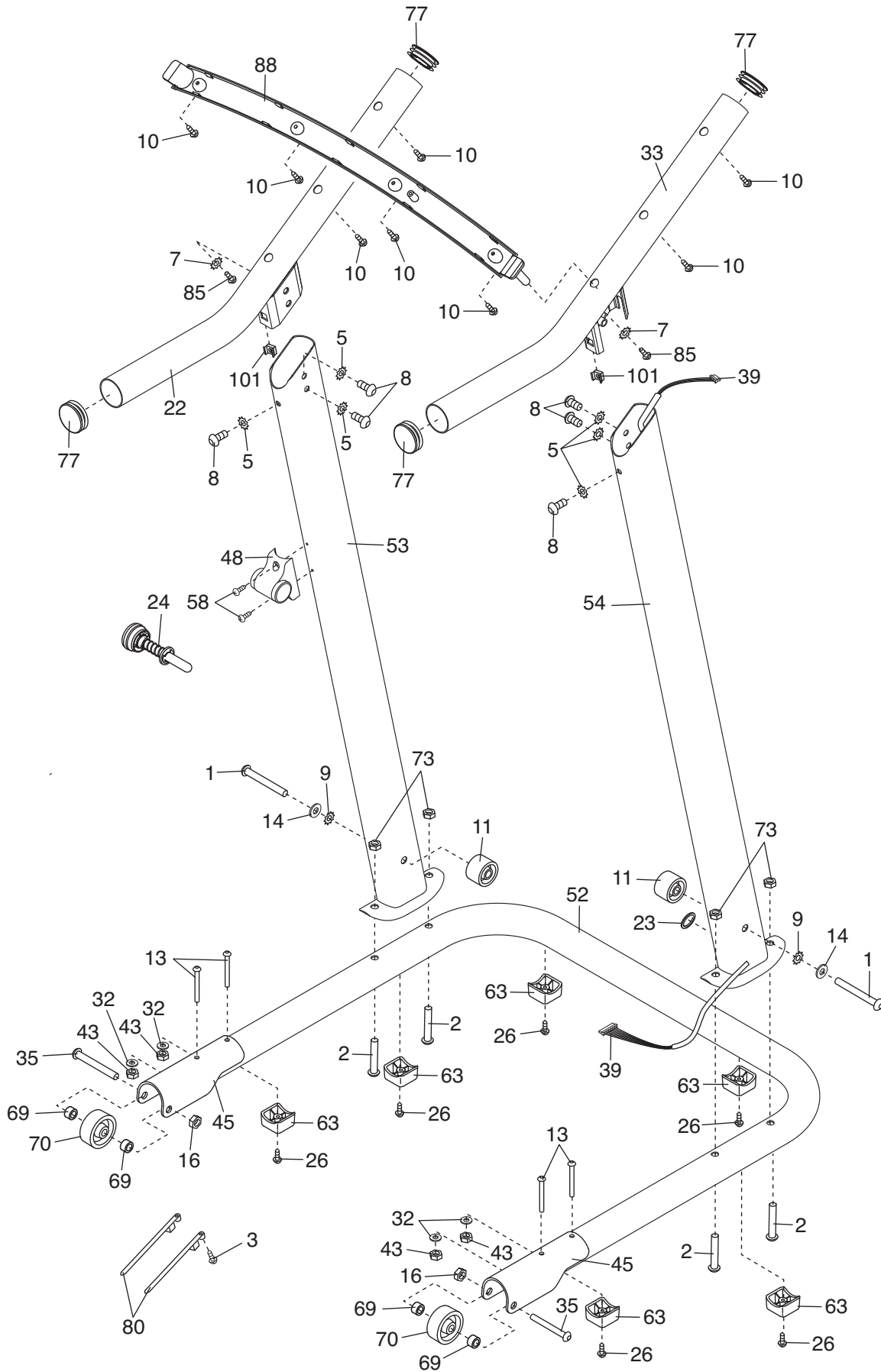

EXPLODED DRAWING D

Model No. WLTL29911.0 R0511A

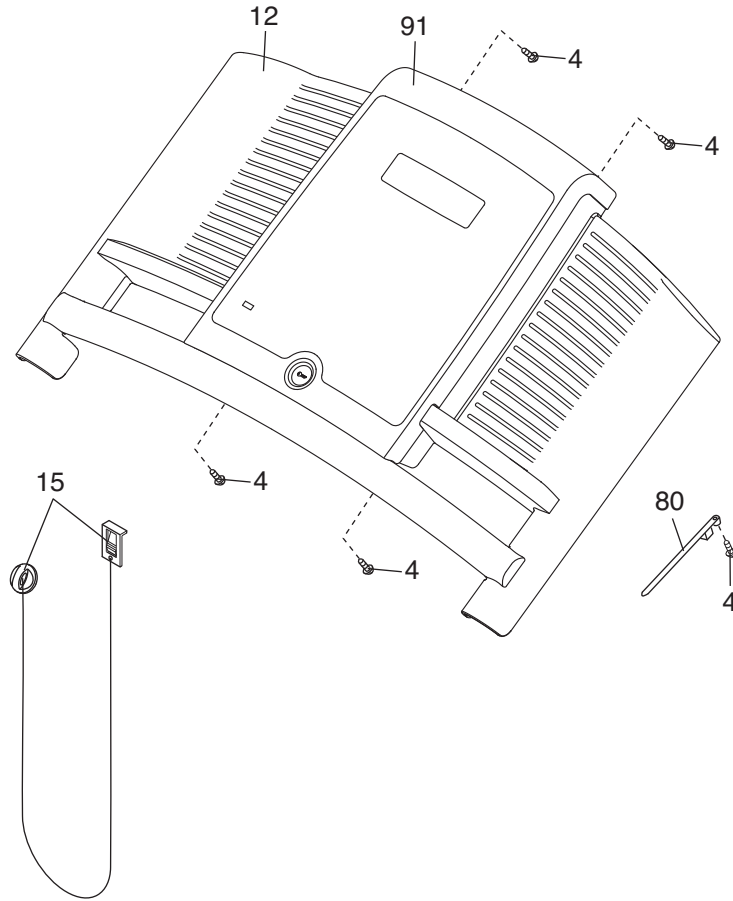

ORDERING REPLACEMENT PARTS

To order replacement parts, please see the front cover of this manual. To help us assist you, be prepared to provide the following information when contacting us:

- the model number and serial number of the product (see the front cover of this manual)
- the name of the product (see the front cover of this manual)
- the key number and description of the replacement part(s) (see the PART LIST and the EXPLODED DRAWING near the end of this manual)

LIMITED WARRANTY

IMPORTANT: You must register this product within 30 days of the purchase date to avoid added fees for service needed under warranty. Go to www.wesloservice.com/registration.

ICON Health & Fitness, Inc. (ICON) warrants this product to be free from defects in workmanship and material, under normal use and service conditions. Parts and labor are warranted for ninety (90) days from the date of purchase.

This warranty extends only to the original purchaser (customer). ICON's obligation under this warranty is limited to repairing or replacing, at ICON's option, the product through one of its authorized service centers. All repairs for which warranty claims are made must be preauthorized by ICON. If the product is shipped to a service center, freight charges to and from the service center will be the customer's responsibility. If replacement parts are shipped while the product is under warranty, the customer will be responsible for a minimal handling charge. For in-home service, the customer will be responsible for a minimal trip charge. This warranty does not extend to freight damage to the product. This warranty will automatically be voided if the product is used as a store display model, if the product is purchased or transported outside the USA, if all instructions in this manual are not followed, if the product is abused or improperly or abnormally used, or if the product is used for commercial or rental purposes. No other warranty beyond that specifically set forth above is authorized by ICON.

ICON is not responsible or liable for indirect, special, or consequential damages arising out of or in connection with the use or performance of the product; damages with respect to any economic loss, loss of property, loss of revenues or profits, loss of enjoyment or use, or costs of removal or installation; or other consequential damages of any kind. Some states do not allow the exclusion or limitation of incidental or consequential damages. Accordingly, the above limitation may not apply to the customer.

The warranty extended hereunder is in lieu of any and all other warranties, and any implied warranties of merchantability or fitness for a particular purpose are limited in their scope and duration to the terms set forth herein. Some states do not allow limitations on how long an implied warranty lasts. Accordingly, the above limitation may not apply to the customer.

This warranty provides specific legal rights; the customer may have other rights that vary from state to state.

ICON Health & Fitness, Inc., 1500 S. 1000 W., Logan, UT 84321-9813

Free Manuals Download Website

<http://myh66.com>

<http://usermanuals.us>

<http://www.somanuals.com>

<http://www.4manuals.cc>

<http://www.manual-lib.com>

<http://www.404manual.com>

<http://www.luxmanual.com>

<http://aubethermostatmanual.com>

Golf course search by state

<http://golfingnear.com>

Email search by domain

<http://emailbydomain.com>

Auto manuals search

<http://auto.somanuals.com>

TV manuals search

<http://tv.somanuals.com>