

WESLO® *CardioStride 3.0*

www.weslo.com

Model No. WLTL99312.0

Serial No. _____

Write the serial number in the space above for future reference.

Serial
Number
Decal

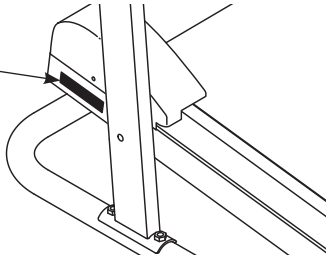

USER'S MANUAL

QUESTIONS?

If you have questions, or if parts are damaged or missing, **DO NOT CONTACT THE STORE**; please contact Customer Care.

IMPORTANT: Please register this product (see the limited warranty on the back cover of this manual) before contacting Customer Care.

CALL TOLL-FREE:

1-866-699-3756

Mon.–Fri. 6 a.m.–6 p.m. MT

Sat. 8 a.m.–4 p.m. MT

ON THE WEB:

www.wesloservice.com

Note: Some replacement parts are available. For information about replacement parts, call Customer Care.

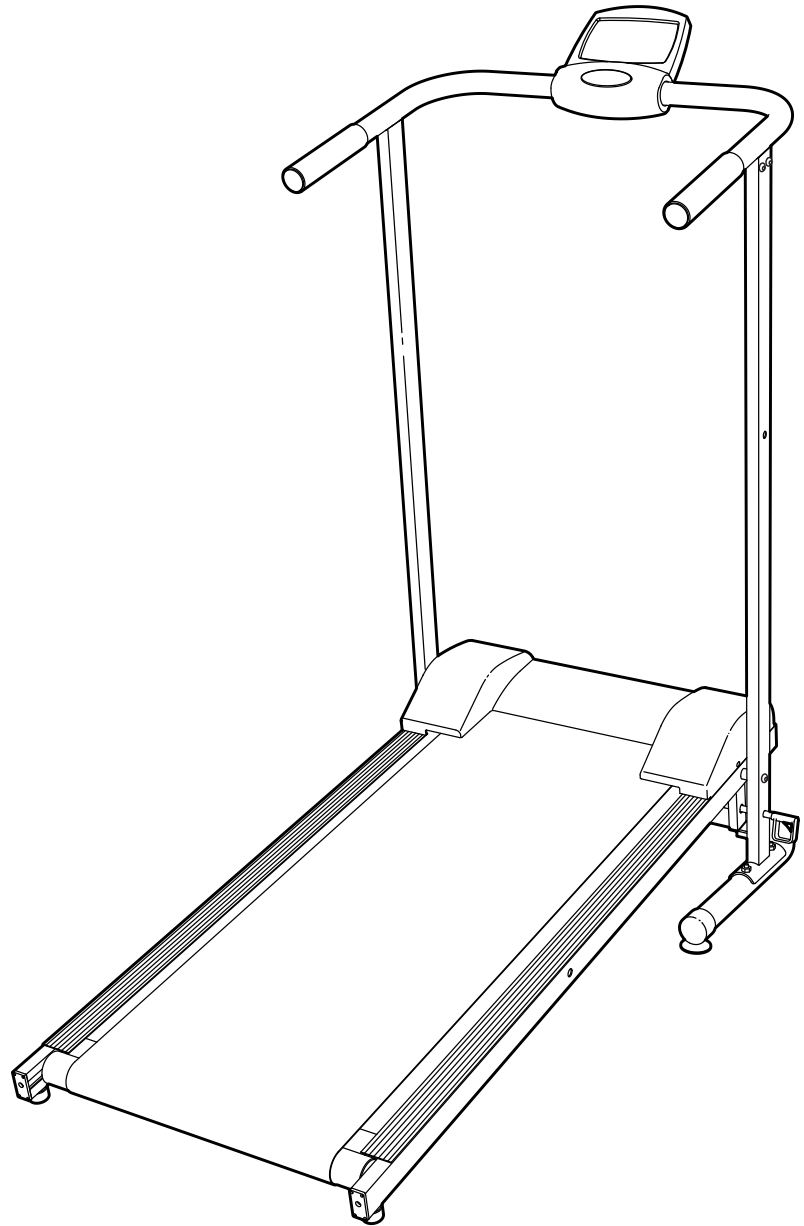

CAUTION

Read all precautions and instructions in this manual before using this equipment. Save this manual for future reference.



TABLE OF CONTENTS

WARNING DECAL PLACEMENT	2
IMPORTANT PRECAUTIONS	3
BEFORE YOU BEGIN	5
PART IDENTIFICATION CHART	6
ASSEMBLY	7
TREADMILL OPERATION	11
HOW TO FOLD THE TREADMILL	13
TROUBLESHOOTING	14
EXERCISE GUIDELINES	15
LIMITED WARRANTY	Back Cover

WARNING DECAL PLACEMENT

This drawing shows the location(s) of the warning decal(s). **If a decal is missing or illegible, call the telephone number on the front cover of this manual and request a free replacement decal. Apply the decal in the location shown.** Note: The decal(s) may not be shown at actual size.

⚠ WARNING
To reduce risk of serious injury, stand on foot rails before starting treadmill; read and understand the user's manual, all instructions, and all warnings before use. Keep children away.

⚠ ADVERTENCIA
Para reducir el riesgo de lesiones serias, párese en los rieles de soporte para los pies antes de comenzar la máquina para correr, lea y entienda el manual del usuario, todas las instrucciones, y las advertencias antes del uso. Mantenga a los niños alejados.

⚠ WARNING:
Protect yourself and others from risk of serious injury. Read the user's manual and:

- Stand only on the side rails when starting or stopping treadmill.
- Change speed in small increments.
- Hold handrails to prevent falling, and always wear the safety key while operating treadmill.
- Stop if you feel faint, dizzy, or short of breath.
- Fully engage storage latch before treadmill is moved or stored.
- Reduce incline to its lowest level before folding treadmill into storage position.

• Never allow children or pets around treadmill.

• Remove key when not in use.

• Keep clothing, fingers, and hair away from moving belt.

• Never try to adjust or fix the belt while it is moving.

• Always wear athletic shoes while operating treadmill.

⚠ ADVERTENCIA:
Protégase y proteja a otros de riesgo de lesiones serias. Lea el manual del usuario y:

- Párese sólo en los rieles de soporte para los pies al comenzar a correr y antes de parar.
- Cambie la velocidad en aumentos pequeños.
- Sostenga los barandales para prevenir caídas y siempre use el seguro mientras corre.
- Pare si se siente débil, mareado o corto de aliento.
- Enganche el seguro de almacenamiento completamente antes que la cinta se corra, se mueva o se gire.
- Reduzca la inclinación al nivel más bajo antes de colgar la cinta de correr a la posición de almacenamiento.

• Nunca permita a los niños estar o jugar a la altura de la cinta de correr.

• Quite la llave cuando no esté en uso.

• Mantenga ropa, dedos, y cabello lejos de la banda de movimiento.

• Nunca trate de ajustar o arreglar la banda mientras que se está moviendo.

• Siempre use zapatos atléticos mientras opera la cinta de correr.

IMPORTANT PRECAUTIONS

⚠️ WARNING: To reduce the risk of burns, fire, electric shock, or injury to persons, read all important precautions and instructions in this manual and all warnings on your treadmill before using your treadmill. ICON assumes no responsibility for personal injury or property damage sustained by or through the use of this product.

1. It is the responsibility of the owner to ensure that all users of this treadmill are adequately informed of all warnings and precautions.
2. Before beginning any exercise program, consult your physician. This is especially important for persons over age 35 or persons with pre-existing health problems.
3. Use the treadmill only as described in this manual.
4. The treadmill is intended for home use only. Do not use the treadmill in any commercial, rental, or institutional setting.
5. Keep the treadmill indoors, away from moisture and dust. Do not put the treadmill in a garage or covered patio, or near water.
6. Place the treadmill on a level surface, with at least 8 ft. (2.4 m) of clearance behind it and 2 ft. (0.6 m) on each side. Do not place the treadmill on any surface that blocks air openings. To protect the floor or carpet from damage, place a mat under the treadmill.
7. Do not operate the treadmill where aerosol products are used or where oxygen is being administered.
8. Keep children under age 12 and pets away from the treadmill at all times.
9. The treadmill should be used only by persons weighing 250 lbs. (113 kg) or less.
10. Never allow more than one person on the treadmill at a time.
11. Wear appropriate exercise clothes while using the treadmill. Do not wear loose clothes that could become caught in the treadmill. Athletic support clothes are recommended for both men and women. *Always wear athletic shoes. Never use the treadmill with bare feet, wearing only stockings, or in sandals.*
12. Do not operate the treadmill if the treadmill is not working properly. (See TROUBLESHOOTING on page 14 if the treadmill is not working properly.)
13. Always hold the handrails while using the treadmill.
14. Do not attempt to raise or lower the treadmill until it is properly assembled. (See ASSEMBLY on page 7 and HOW TO FOLD THE TREADMILL on page 13.) You must be able to safely lift 25 lbs. (11 kg) to raise or lower the treadmill.
15. When folding the treadmill, make sure that the storage latch is holding the frame securely in the storage position.
16. Do not change the incline of the treadmill by placing objects under the treadmill.
17. Inspect and properly tighten all parts of the treadmill regularly.

18. Never drop or insert any object into any opening on the treadmill.

19. Servicing other than the procedures in this manual should be performed by an authorized service representative only.

20. Over exercising may result in serious injury or death. If you feel faint or if you experience pain while exercising, stop immediately and cool down.

21. Do not place hands or feet under the treadmill while it is in use.

22. The roller guards must be 1/8 inch from the rear roller (see the drawing on page 5). Adjust the roller guards, if necessary.

SAVE THESE INSTRUCTIONS

BEFORE YOU BEGIN

Thank you for selecting the new WESLO® CARDIO STRIDE 3.0 treadmill. The CARDIO STRIDE 3.0 treadmill offers a selection of features designed to make your workouts at home more effective. And when you're not exercising, the unique treadmill can be folded up, requiring less than half the floor space of other treadmills.

For your benefit, read this manual carefully before using the treadmill. If you have questions after

reading this manual, please see the front cover of this manual. To help us assist you, note the product model number and serial number before contacting us. The model number and the location of the serial number decal are shown on the front cover of this manual.

Before reading further, please familiarize yourself with the parts that are labeled in the drawing below.

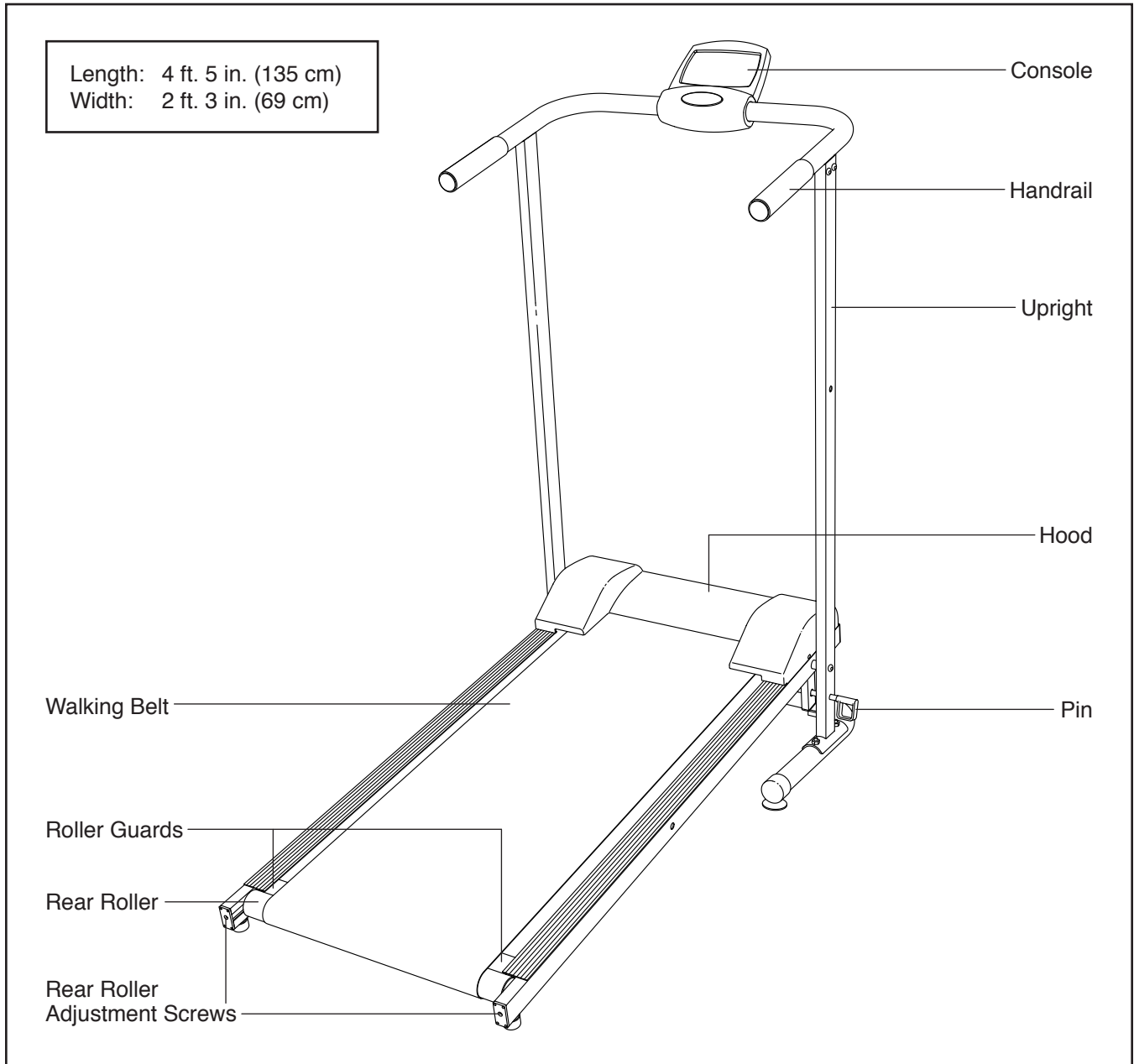

PART IDENTIFICATION CHART

Use the drawings below to identify small parts used for assembly. The number in parentheses below each drawing is the key number of the part, from the PART LIST near the end of this manual. The number following the key number is the quantity used for assembly. **Note: If a part is not in the hardware kit, check to see if it is pre-attached. Extra parts may be included.**

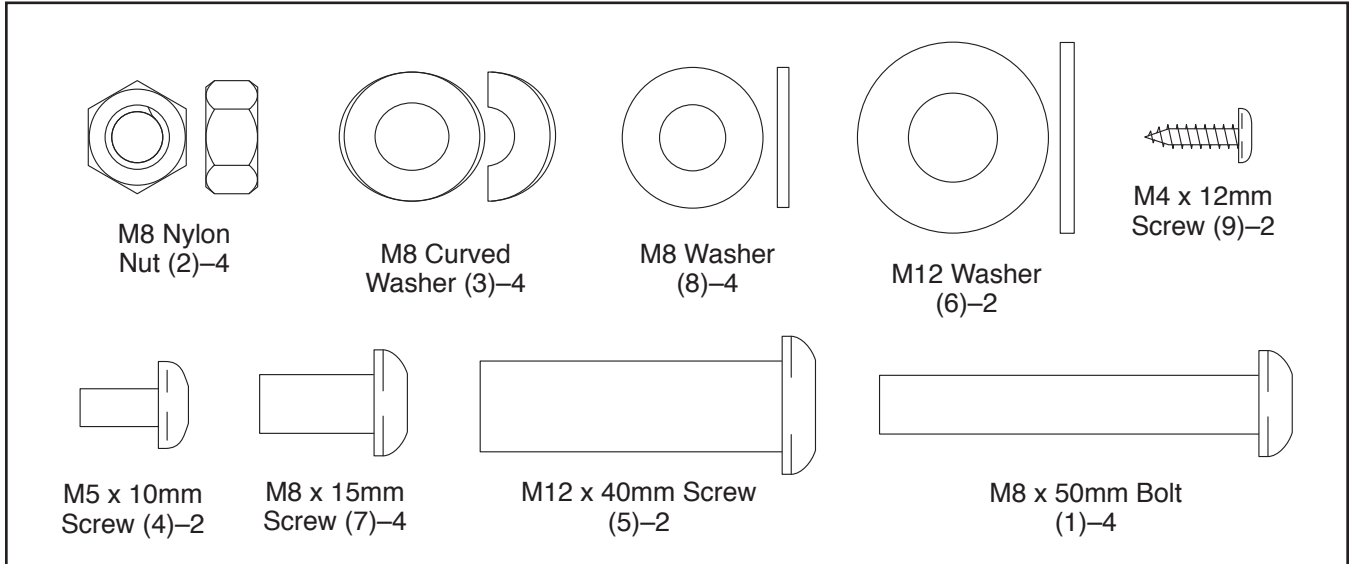

ASSEMBLY

- To watch an assembly video, go to <http://productvideo.co/assembly/kmart/weslo> or use your mobile phone or smartphone to read the QR code at the right. A reader application such as ShopSavvy must be installed on your mobile phone or smartphone.



- To hire an authorized service technician to assemble your exercise equipment, call 1-800-445-2480.
- Assembly requires two persons.
- Place all parts in a cleared area and remove the packing materials. Do not dispose of the packing materials until you finish all assembly steps.

- After shipping, there may be an oily substance on the exterior of the treadmill. This is normal. If there is an oily substance on the treadmill, wipe it off with a soft cloth and a mild, non-abrasive cleaner.
- Left parts are marked “L” or “Left” and right parts are marked “R” or “Right.”
- To identify small parts, see page 6.

- Assembly requires the following tools:

the included hex key 

one adjustable wrench 

To avoid damaging parts, do not use power tools.

1. Identify the Right Upright (10), which has a single hole in the indicated location. (Note: There is a wire inside of the Left Upright [11].) Hold the Right Upright against the Base (12) as shown, and orient the Right Upright so that the two indicated holes are on the side shown.

Attach the Right Upright (10) to the Base (12) with two M8 x 50mm Bolts (1), two M8 Curved Washers (3), and two M8 Nylon Nuts (2) as shown. Make sure that the curved sides of the Washers are against the Base. **Do not tighten the Nylon Nuts yet.**

Attach the Left Upright (11) to the Base (12) in the same way. Make sure that the Left Upright is oriented so that the two indicated holes are on the side shown. **Do not tighten the Nylon Nuts yet.**

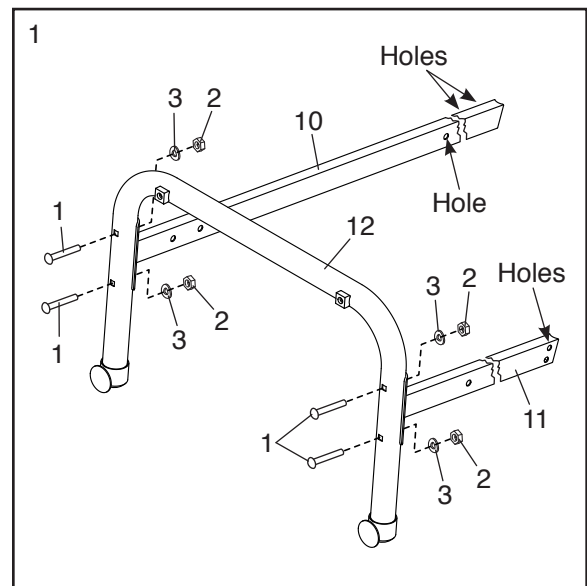

2. Raise the Left Upright (11) and the Right Upright (10) to the position shown.

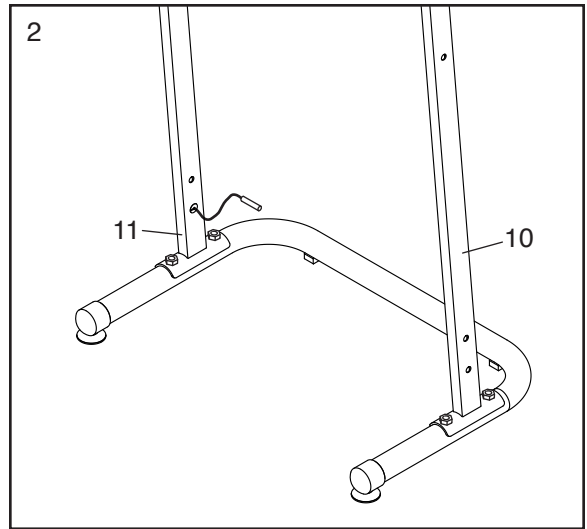

3. Attach the Hood (13) to the front of the Frame (14) with two M5 x 10mm Screws (4).

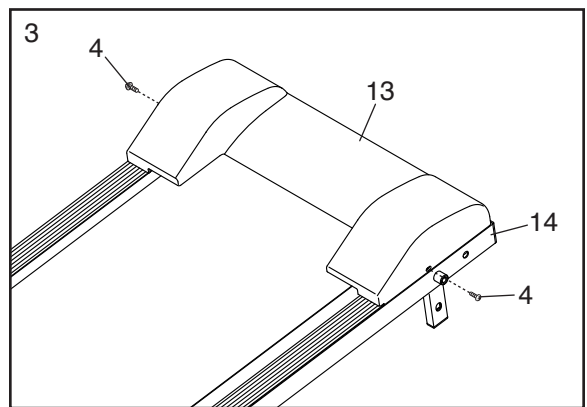

4. Hold the front of the Frame (14) between the Left Upright (11) and the Right Upright (10). Align the holes near the front of the Frame with the upper holes shown in the Uprights. Tighten an M12 x 40mm Screw (5) with an M12 Washer (6) into each Upright and into the Frame.

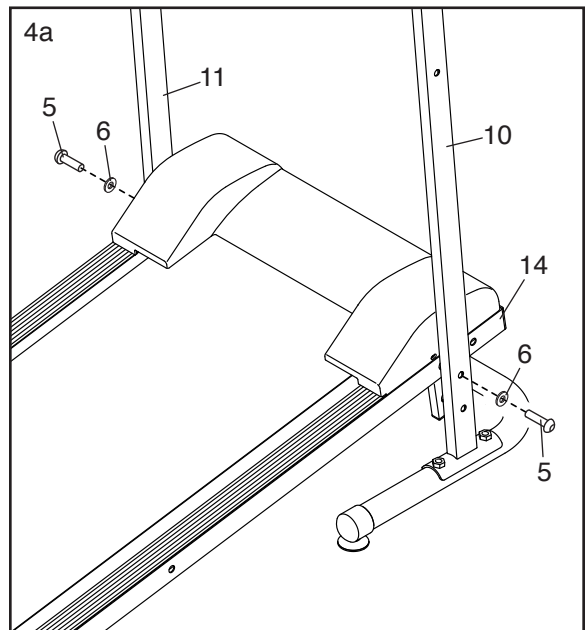

- Align the hole on the Frame (14) with the hole in the Right Upright (10). Insert the Pin (15) into the holes in the Upright and the Frame. **Make sure that the Pin is fully inserted.**

Look under the Frame (14) near the Left Upright (11). **See drawing 5b.** Locate the Reed Switch Clip (16) attached to the underside of the Frame. Insert the Reed Switch (17) into the Reed Switch Clip as shown. Next, locate the Magnet (18) on the Flywheel (19). Turn the Flywheel until the Magnet is aligned with the Reed Switch. **Move the Reed Switch so that there is a 1/8" (3 mm) gap between the Reed Switch and the Magnet.**

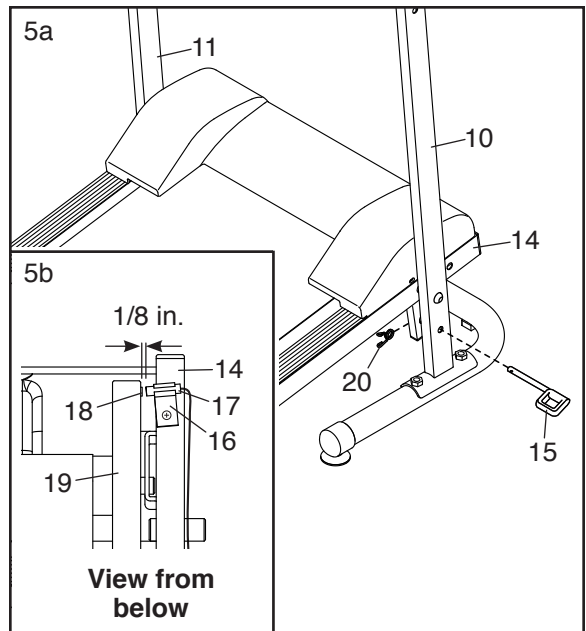

- Hold the Handrail (27) near the Left and Right Uprights (11, 10). Connect the Handrail Wire (21) to the Reed Switch Wire (22). Insert the Wires down into the Left Upright.

Attach the Handrail (27) to the Uprights (11, 10) with four M8 x 15mm Screws (7) and four M8 Washers (8). **Be careful not to pinch the Wires (21, 22). Do not fully tighten the Screws yet.**

Place the treadmill in the storage position (see page 13). Center the Frame (not shown) between the Uprights (11, 10).

See step 1. Tighten the four M8 Nylon Nuts (2). Then, tighten the M8 x 15mm Screws (7). Lower the Frame (see page 13).

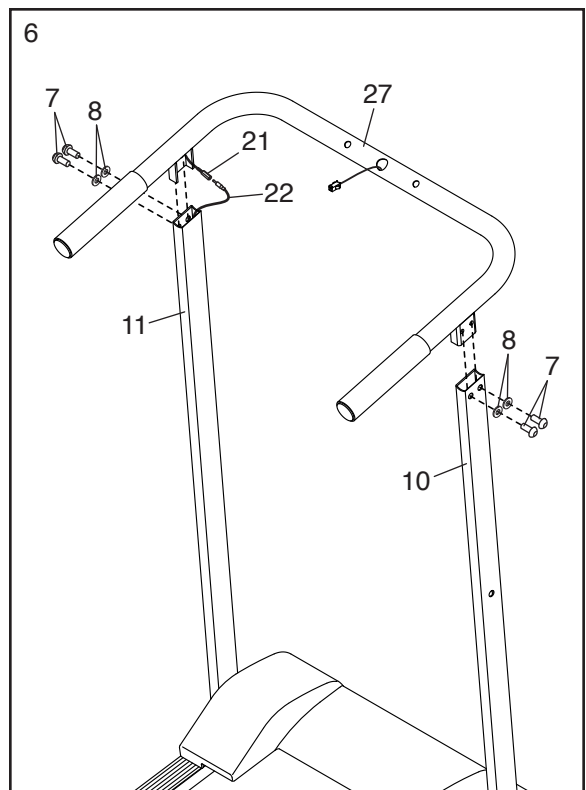

7. The Console (23) requires two “AAA” batteries. Alkaline batteries are recommended. Do not use old and new batteries together or alkaline, standard, and rechargeable batteries together.

Press the indicated tab on the Battery Cover (24), and remove the Battery Cover. Insert two batteries into the two battery clips; **make sure that the negative (-) ends of the batteries are touching the springs in the battery clips.**

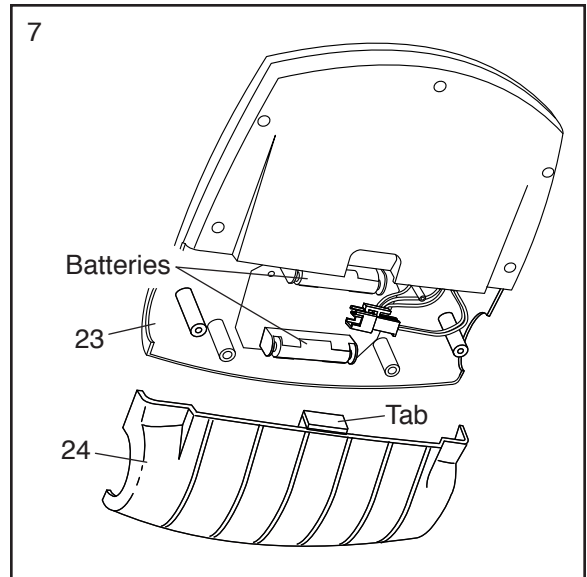

8. **See drawing 8a.** Hold the Console (23) near the Handrail (27). Connect the wire on the Console to the Handrail Wire (21).

Attach the Console (23) to the Handrail (27) with two M4 x 12mm Screws (9). **Do not overtighten the Screws. Make sure that the wires are not pinched.**

See drawing 8b. Press the Battery Cover (24) back onto the Console (23).

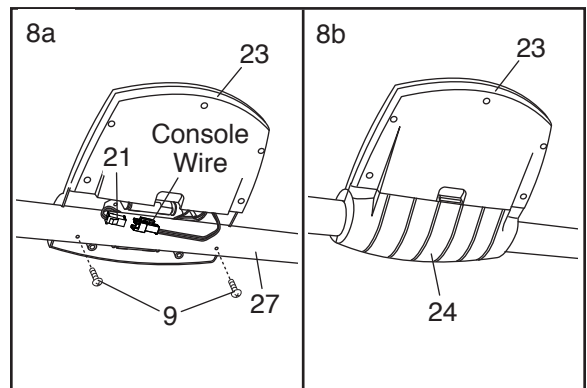

9. Remove the paper backing from the Adhesive Clip (25). Press the Adhesive Clip onto the left side of the Frame (14) in the indicated location. Press the Hex Key (26) into the Adhesive Clip.

Make sure that the walking belt is properly tightened (see SYMPTOM 3 on page 14).

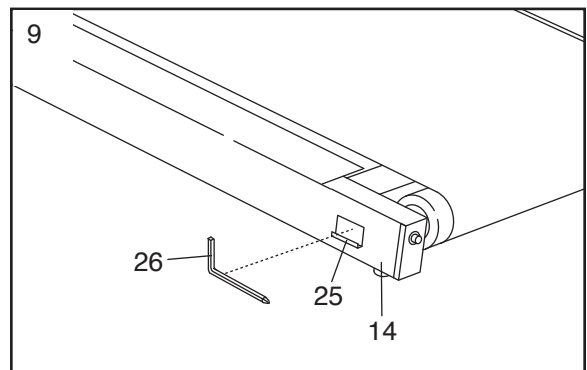

10. **Make sure that all parts are properly tightened before you use the treadmill.** To protect the floor or carpet, place a mat under the treadmill.

TREADMILL OPERATION

STEP-BY-STEP CONSOLE OPERATION

Before the console can be operated, batteries must be installed (see assembly step 7 on page 10). If there is a thin sheet of plastic on the console, remove the plastic.

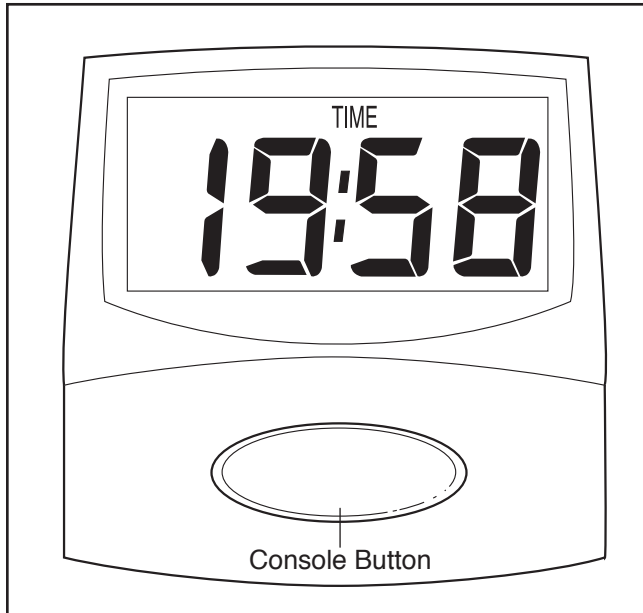

The console features six modes:

- Speed—This mode displays your speed in miles per hour.
- Distance—This mode displays the number of miles you have walked.
- Time—This mode displays the elapsed time.
- Odometer—This mode displays the distance that the walking belt has moved since the batteries were changed.
- Calorie—This mode displays the approximate number of calories you have burned.
- Scan—This mode displays the Speed, Distance, Time, Odometer, and Calorie modes in a repeating cycle.

Follow the steps below to operate the console.

1. Turn on the power.

To turn on the power, press the console button or begin walking. Note: If batteries were just installed, the power will already be on. The first time you use the treadmill, lubricate the walking platform (see page 12).

2. Track your progress with the six modes.

When the power is turned on, the Scan mode will be selected and the SCAN indicator will appear. The console will display the Speed, Distance, Time, Odometer, and Calorie modes, for about six seconds each, in a repeating cycle.

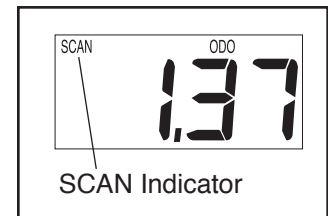

To select only the Speed, Distance, Time, Odometer, or Calorie mode, press the console button until only the SPEED, DIST, TIME, ODO, or CAL indicator appears in the display. Make sure that the SCAN indicator does not appear.

To reset all modes (except for the odometer mode), press the console button for about three seconds.

3. Turn off the power.

To turn off the power, simply wait for a few minutes. If the walking belt is not moved and the console button is not pressed for a few minutes, **the power will turn off automatically.**

LUBRICATING THE WALKING PLATFORM

Before the treadmill is used, the walking platform should be lubricated. Open the included lubricant packet. Reach under one side of the walking belt as far as you can, and apply half of the lubricant to the walking platform. Then, reach under the other side of the walking belt and apply the remaining lubricant. **After you have applied the lubricant, walk on the treadmill for a few minutes to spread the lubricant.**

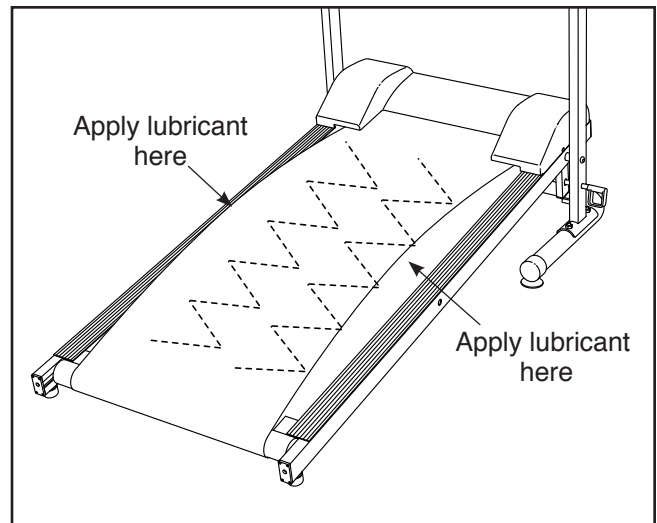

HOW TO FOLD THE TREADMILL

FOLDING THE TREADMILL FOR STORAGE

When the treadmill is not in use, it can be folded to the compact storage position. **CAUTION: You must be able to safely lift 25 pounds (11 kg) to raise or lower the treadmill.**

1. Remove the Pin (15) from the right side of the treadmill. Hold the end of the Frame (14) firmly with your hands. **CAUTION: Bend your legs and keep your back straight. As you raise the Frame, make sure to lift with your legs rather than your back.** Raise the Frame to the vertical position.

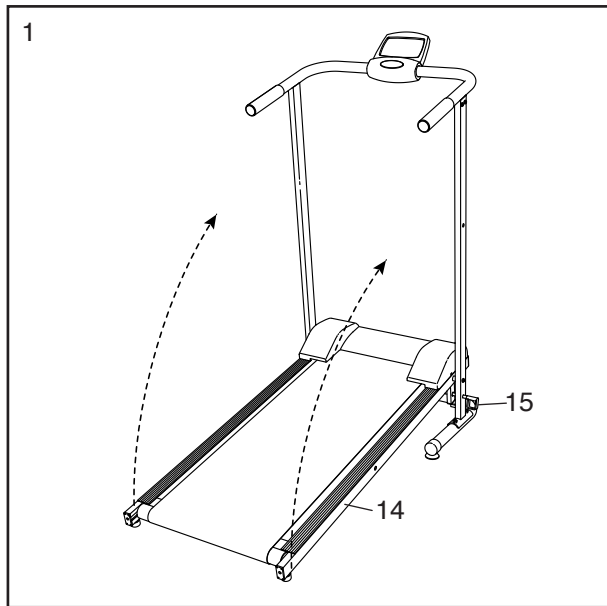

2. Hold the treadmill securely with your left hand as shown. Insert the Pin (15) into the hole in the right side of the Right Upright (10) and into the Frame (14) as far as it will go.

Press the ends of the Spring Clip (20) together and slide the Spring Clip onto the end of the Pin (15).

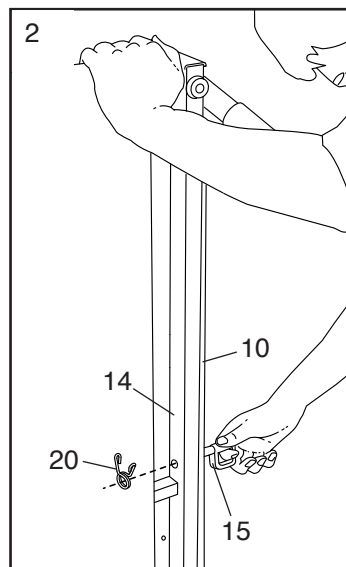

LOWERING THE TREADMILL FOR USE

1. Hold the treadmill securely with your left hand as shown in drawing 2. Press the ends of the Spring Clip (20) together and slide the Spring Clip off the end of the Pin (15). Pull out the Pin and pivot the treadmill downward a few inches.
2. Hold the treadmill firmly with both hands, and lower the treadmill to the floor. **CAUTION: Bend your legs and keep your back straight.** Then, reinsert the pin and reattach the spring clip.

TROUBLESHOOTING

Most treadmill problems can be solved by following the steps below. Find the symptom that applies, and follow the steps listed. If further assistance is needed, please see the front cover of this manual.

1. SYMPTOM: THE CONSOLE DOES NOT FUNCTION PROPERLY

- Replace the batteries in the console (see assembly step 7 on page 10).
- Make sure that the reed switch is properly adjusted (see assembly step 5 on page 9).
- Make sure that the handrail wire is plugged fully into the wire on the console (see assembly step 8 on page 10).
- The console, like most electronics, is susceptible to static electricity build-up caused by certain types of clothing or by the operation of the treadmill. If the display is blank or gives incorrect readings, apply an anti-static spray to the handrail. Anti-static spray is available where laundry supplies are sold.

2. SYMPTOM: THE WALKING BELT DOES NOT MOVE SMOOTHLY

- If the walking belt is over-tightened, performance may be reduced and the walking belt may be permanently damaged. Using the hex key, turn both

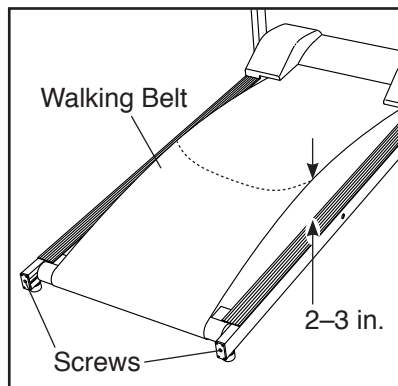

rear roller adjustment screws counterclockwise 1/4 of a turn. When the walking belt is properly tightened, you should be able to lift each edge of the walking belt 2 to 3 in. (5 to 7 cm) off the walking platform. Be careful to keep the walking belt centered. Walk on the treadmill for a few minutes. Repeat until the walking belt is properly tightened.

3. SYMPTOM: THE WALKING BELT SLIPS OR IS OFF-CENTER

- If the walking belt slips when walked on, use the hex key to turn both adjustment screws clockwise,

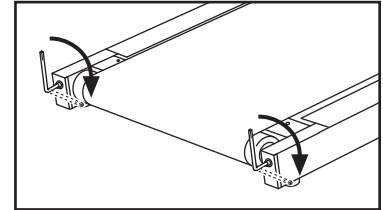

1/4 of a turn. When the walking belt is properly tightened, you should be able to lift each edge of the walking belt 2 to 3 in. (5 to 7 cm) off the walking platform. Be careful to keep the walking belt centered. Walk on the treadmill for a few minutes. Repeat until the walking belt is properly tightened.

- If the walking belt has shifted to the left side, use the hex key to turn the left adjustment screw

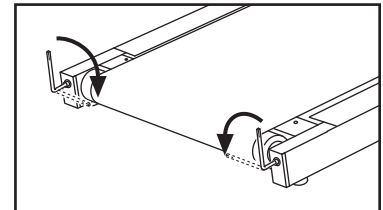

clockwise, and the right adjustment screw counterclockwise, 1/4 of a turn each. Be careful not to overtighten the walking belt. Walk on the treadmill for a few minutes. Repeat until the walking belt is centered.

- If the walking belt has shifted to the right side, use the hex key to turn the left adjustment screw

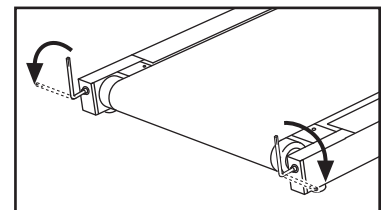

counterclockwise, and the right adjustment screw clockwise, 1/4 of a turn each. Be careful not to overtighten the walking belt. Walk on the treadmill for a few minutes. Repeat until the walking belt is centered.

EXERCISE GUIDELINES

⚠️ WARNING: Before beginning this or any exercise program, consult your physician. This is especially important for persons over age 35 or persons with pre-existing health problems.

These guidelines will help you to plan your exercise program. For detailed exercise information, obtain a reputable book or consult your physician. Remember, proper nutrition and adequate rest are essential for successful results.

EXERCISE INTENSITY

Whether your goal is to burn fat or to strengthen your cardiovascular system, exercising at the proper intensity is the key to achieving results. You can use your heart rate as a guide to find the proper intensity level. The chart below shows recommended heart rates for fat burning and aerobic exercise.

165	155	145	140	130	125	115	♥♥
145	138	130	125	118	110	103	♥
125	120	115	110	105	95	90	♥
<hr/>							
20	30	40	50	60	70	80	

To find the proper intensity level, find your age at the bottom of the chart (ages are rounded off to the nearest ten years). The three numbers listed above your age define your “training zone.” The lowest number is the heart rate for fat burning, the middle number is the heart rate for maximum fat burning, and the highest number is the heart rate for aerobic exercise.

Burning Fat—To burn fat effectively, you must exercise at a low intensity level for a sustained period of time. During the first few minutes of exercise, your body uses carbohydrate calories for energy. Only after the first few minutes of exercise does your body begin to use stored fat calories for energy. If your goal is to burn fat, adjust the intensity of your exercise until your heart rate is near the lowest number in your training zone. For maximum fat burning, exercise with your heart rate near the middle number in your training zone.

Aerobic Exercise—If your goal is to strengthen your cardiovascular system, you must perform aerobic exercise, which is activity that requires large amounts of oxygen for prolonged periods of time. For aerobic exercise, adjust the intensity of your exercise until your heart rate is near the highest number in your training zone.

HOW TO MEASURE YOUR HEART RATE

To measure your heart rate, exercise for at least four minutes. Then, stop exercising and place two fingers on your wrist as shown. Take a six-second heartbeat count, and multiply the result by 10 to find your heart rate. For example, if your six-second heartbeat count is 14, your heart rate is 140 beats per minute.

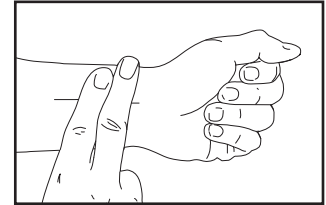

WORKOUT GUIDELINES

Warming Up—Start with 5 to 10 minutes of stretching and light exercise. A warm-up increases your body temperature, heart rate, and circulation in preparation for exercise.

Training Zone Exercise—Exercise for 20 to 30 minutes with your heart rate in your training zone. (During the first few weeks of your exercise program, do not keep your heart rate in your training zone for longer than 20 minutes.) Breathe regularly and deeply as you exercise; never hold your breath.

Cooling Down—Finish with 5 to 10 minutes of stretching. Stretching increases the flexibility of your muscles and helps to prevent post-exercise problems.

EXERCISE FREQUENCY

To maintain or improve your condition, complete three workouts each week, with at least one day of rest between workouts. After a few months of regular exercise, you may complete up to five workouts each week, if desired. Remember, the key to success is to make exercise a regular and enjoyable part of your everyday life.

LIMITED WARRANTY

IMPORTANT: You must register this product within 30 days of the purchase date to avoid added fees for service needed under warranty. Go to www.wesloservice.com/registration.

ICON Health & Fitness, Inc. (ICON) warrants this product to be free from defects in workmanship and material, under normal use and service conditions. Parts and labor are warranted for ninety (90) days from the date of purchase.

This warranty extends only to the original purchaser (customer). ICON's obligation under this warranty is limited to repairing or replacing, at ICON's option, the product through one of its authorized service centers. All repairs for which warranty claims are made must be preauthorized by ICON. If the product is shipped to a service center, freight charges to and from the service center will be the customer's responsibility. If replacement parts are shipped while the product is under warranty, the customer will be responsible for a minimal handling charge. For in-home service, the customer will be responsible for a minimal trip charge. This warranty does not extend to freight damage to the product. This warranty will automatically be voided if the product is used as a store display model, if the product is purchased or transported outside the USA, if all instructions in this manual are not followed, if the product is abused or improperly or abnormally used, or if the product is used for commercial or rental purposes. No other warranty beyond that specifically set forth above is authorized by ICON.

ICON is not responsible or liable for indirect, special, or consequential damages arising out of or in connection with the use or performance of the product; damages with respect to any economic loss, loss of property, loss of revenues or profits, loss of enjoyment or use, or costs of removal or installation; or other consequential damages of any kind. Some states do not allow the exclusion or limitation of incidental or consequential damages. Accordingly, the above limitation may not apply to the customer.

The warranty extended hereunder is in lieu of any and all other warranties, and any implied warranties of merchantability or fitness for a particular purpose are limited in their scope and duration to the terms set forth herein. Some states do not allow limitations on how long an implied warranty lasts. Accordingly, the above limitation may not apply to the customer.

This warranty provides specific legal rights; the customer may have other rights that vary from state to state.

ICON Health & Fitness, Inc., 1500 S. 1000 W., Logan, UT 84321-9813

Free Manuals Download Website

<http://myh66.com>

<http://usermanuals.us>

<http://www.somanuals.com>

<http://www.4manuals.cc>

<http://www.manual-lib.com>

<http://www.404manual.com>

<http://www.luxmanual.com>

<http://aubethermostatmanual.com>

Golf course search by state

<http://golfingnear.com>

Email search by domain

<http://emailbydomain.com>

Auto manuals search

<http://auto.somanuals.com>

TV manuals search

<http://tv.somanuals.com>