

# My Book® VelociRaptor™ Duo

## Dual-drive Storage System

### User Manual

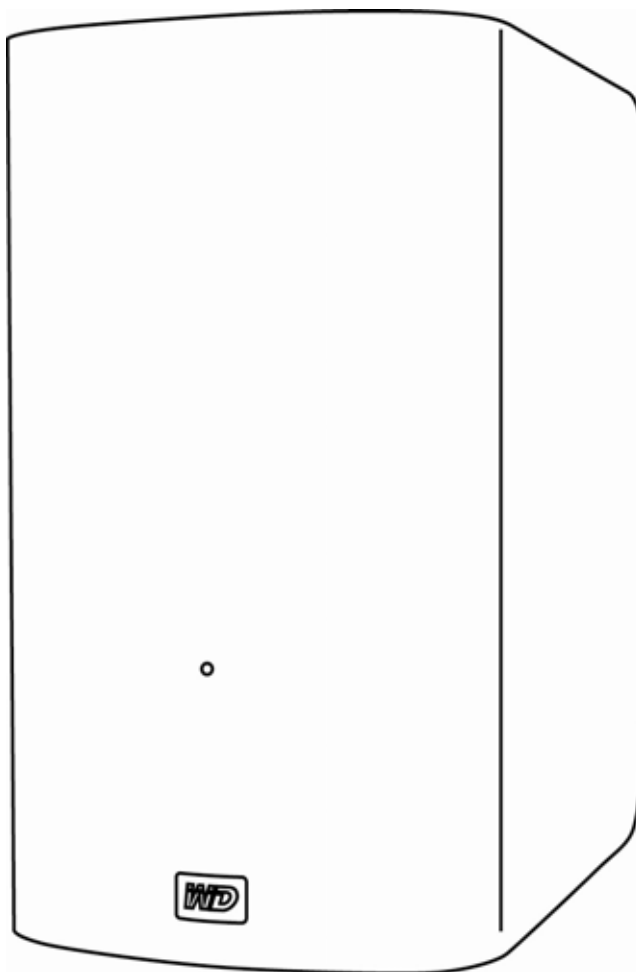

## WD Service and Support

Should you encounter any problem, please give us an opportunity to address it before returning this product. Most technical support questions can be answered through our knowledge base or email support service at <http://support.wdc.com>. If the answer is not available or if you prefer, please contact WD® at the best telephone number shown below.

Your product includes 30 days of free telephone support during the warranty period. This 30-day period starts on the date of your first telephone contact with WD Technical Support. Email support is free for the entire warranty period and our extensive knowledge base is available 24/7. To help us keep you informed of new features and services, remember to register your product online at <http://register.wdc.com>.

### Accessing Online Support

Visit our product support website at <http://support.wdc.com> and choose from these topics:

- **Downloads**—Download drivers, software, and updates for your WD product.
- **Registration**—Register your WD product to get the latest updates and special offers.
- **Warranty & RMA Services**—Get warranty, product replacement (RMA), RMA status, and data recovery information.
- **Knowledge Base**—Search by keyword, phrase, or answer ID.
- **Installation**—Get online installation help for your WD product or software.
- **WD Community**—Share your thoughts and connect with other WD users.

### Contacting WD Technical Support

When contacting WD for support, have your WD product serial number, system hardware, and system software versions available.

North America		Asia Pacific	
English	800.ASK.4WDC (800.275.4932)	Australia	1 800 42 9861
Spanish	800.832.4778	China	800 820 6682/+65 62430496
		Hong Kong	+800 6008 6008
		India	1 800 11 9393 (MNTL)/1 800 200 5789 (Reliance) 011 26384700 (Pilot Line)
<b>Europe (toll free)*</b>	00800 ASK4 WDEU (00800 27549338)	Indonesia	+803 852 9439
		Japan	0120 994 120/00531 65 0442
		Korea	02 703 6550
<b>Europe</b>	+31 880062100	Malaysia	+800 6008 6008/1 800 88 1908/+65 62430496
<b>Middle East</b>	+31 880062100	Philippines	1 800 1441 0159
<b>Africa</b>	+31 880062100	Singapore	+800 6008 6008/+800 608 6008/+65 62430496
		Taiwan	+800 6008 6008/+65 62430496

\* Toll free number is available in the following countries: Austria, Belgium, Denmark, France, Germany, Ireland, Italy, Netherlands, Norway, Spain, Sweden, Switzerland, United Kingdom.

# Table of Contents

WD Service and Support . . . . .	ii
Accessing Online Support . . . . .	ii
Contacting WD Technical Support. . . . .	ii
<b>1 About Your WD Storage Device . . . . .</b>	<b>1</b>
Features . . . . .	1
Kit Contents . . . . .	2
Optional Accessories . . . . .	3
Operating System Compatibility. . . . .	3
Disk Drive Formats . . . . .	3
Physical Description . . . . .	4
Power/Activity LED. . . . .	4
Thunderbolt Ports. . . . .	5
Kensington® Security Slot . . . . .	5
Registering Your Device . . . . .	5
Handling Precautions . . . . .	5
<b>2 Connecting the Device and Getting Started . . . . .</b>	<b>6</b>
Connecting the Device . . . . .	6
Installing the WD Drive Utilities Software . . . . .	8
<b>3 Managing and Customizing the Device . . . . .</b>	<b>10</b>
Checking Device Health . . . . .	10
Managing the RAID Configuration . . . . .	12
Checking the Device Status . . . . .	12
Changing the Device Configuration . . . . .	13
Erasing the Device Drives. . . . .	16
Registering the Device . . . . .	18
Restoring the WD Software and Disk Image . . . . .	19
Safely Dismounting the Device Drives . . . . .	20
<b>4 Replacing a Drive . . . . .</b>	<b>21</b>
Determining Which Drive Failed . . . . .	21
Contacting WD Technical Support. . . . .	22
Removing and Replacing the Drive . . . . .	22
<b>A Compliance and Warranty Information. . . . .</b>	<b>28</b>
Regulatory Compliance . . . . .	28
FCC Class B Information . . . . .	28
ICES/NMB-003 Compliance. . . . .	28
Safety Compliance . . . . .	28
CE Compliance for Europe. . . . .	28
GS Mark (Germany only) . . . . .	29
KC Notice (Republic of Korea only) . . . . .	29
Environmental Compliance (China). . . . .	29
Warranty Information (All Regions Except Australia/New Zealand) . . . . .	29
Obtaining Service. . . . .	29
Limited Warranty . . . . .	30

Warranty Information (Australia/New Zealand) . . . . . 30  
    Obtaining Service . . . . . 31  
    Warranty . . . . . 31  
GNU General Public License (“GPL”) . . . . . 32  
**Index . . . . . 33**

# About Your WD Storage Device

Welcome to your My Book® VelociRaptor™ Duo dual-drive storage device, uniting the extreme speed of two 10,000 RPM WD VelociRaptor® drives with revolutionary Thunderbolt™ technology to set new standards for data transfer speeds and workflow flexibility in high-capacity storage.

This chapter includes the following topics:

- [Features](#)
- [Kit Contents](#)
- [Optional Accessories](#)
- [Operating System Compatibility](#)
- [Disk Drive Formats](#)
- [Physical Description](#)
- [Registering Your Device](#)
- [Handling Precautions](#)

## Features

**Extreme speed, high capacity storage**—Built with two 10,000 RPM WD VelociRaptor drives inside, My Book VelociRaptor Duo delivers extreme speed and high capacity for high-end video and photo editing, 3D rendering, graphic-intensive design and more.

**Move data at unprecedented speeds**—The Thunderbolt connector provides two channels of up to 10 Gb/s transfer rate in both directions. This allows data to travel both ways without compromising bandwidth. And this means you can do more work in less time with the ground-breaking data transfer speed of the Thunderbolt technology.

**User-configurable RAID for speed or double-safe data protection**—Select the mode that is right for you:

- RAID 0 (Striped mode) for maximum capacity and accelerated performance.
- RAID 1 (Mirrored mode) for double-safe data protection by automatically creating a second copy of your data. One drive stores your data and the other saves a second copy. If either drive fails, your data is protected because it is duplicated on the other drive.
- JBOD (Individual Drives mode) for using the two drives independently, and not configured into a RAID array. In JBOD (Just a Bunch of Disks) mode, you can choose either HFS+J or exFAT format for each drive: HFS+J for Mac applications or exFAT for running Windows® operating systems on a Mac computer.

**Daisy chain more drives for more speed**—Use the two Thunderbolt ports to daisy chain more drives for more speed and higher capacity. Connect a Thunderbolt display and other Thunderbolt-enabled peripherals to achieve maximum efficiency and productivity.

**High-speed multitasking**—The revolutionary bidirectional Thunderbolt technology delivers unmatched speed for multitasking projects.

**Super-fast external boot capability**—For information about using your My Book VelociRaptor Duo as an external boot device using Mac OS X 10.6.8 or later operating system, see the Apple Support article at <http://support.apple.com/kb/HT4718> or <http://docs.info.apple.com/article.html?path=Mac/10.7/en/mchlp1034.html>.

**User serviceable**—When you need to replace a drive, just open the case and do it yourself. No tools are needed.

**WD Drive Utilities™ software**—Keep your device performing at its best by configuring the drives, running diagnostics, and more.

---

**Important:** For the latest WD product information and news, visit our website at <http://www.westerndigital.com>. For the latest software, firmware, and product documentation and information, go to <http://support.wdc.com/downloads>.

---

## Kit Contents

As shown in Figure 1, your My Book VelociRaptor Duo dual-drive storage device kit includes the following:

- My Book VelociRaptor Duo dual-drive storage device
- AC adapter (configuration varies, depending on region)
- Thunderbolt cable
- Quick Install Guide
- WD Drive Utilities software (included on the device)

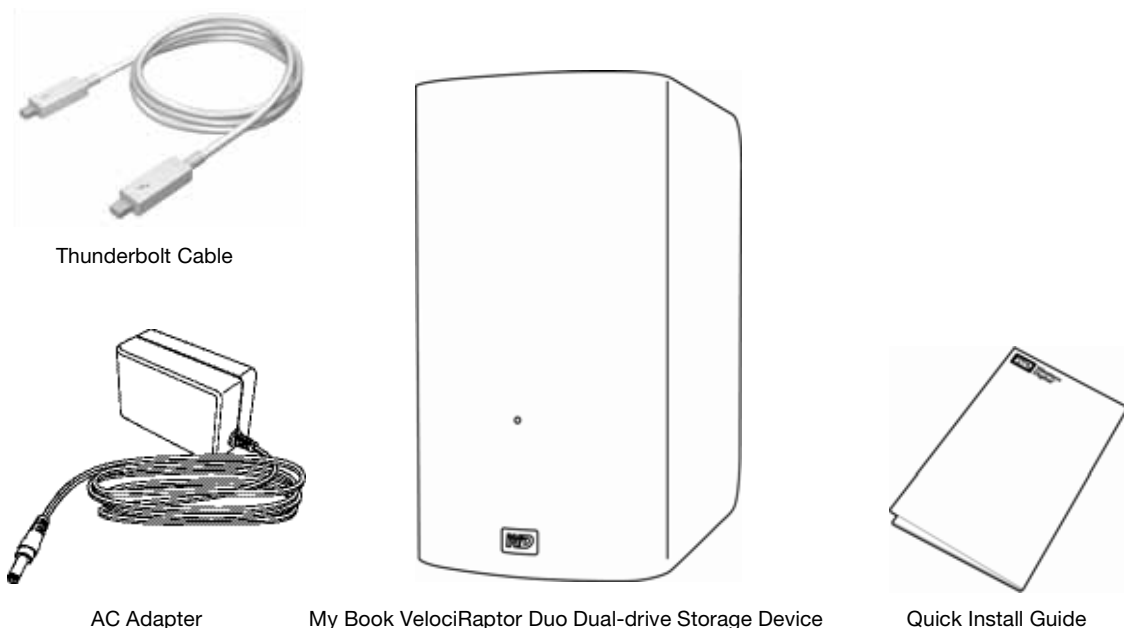

Figure 1. My Book VelociRaptor Duo Dual-drive Storage Device Kit Components

## Optional Accessories

For information about optional accessories for WD products, visit:

US	<a href="http://www.shopwd.com">http://www.shopwd.com</a> or <a href="http://www.wdstore.com">http://www.wdstore.com</a>
Canada	<a href="http://www.shopwd.ca">http://www.shopwd.ca</a> or <a href="http://www.wdstore.ca">http://www.wdstore.ca</a>
Europe	<a href="http://www.shopwd.eu">http://www.shopwd.eu</a> or <a href="http://www.wdstore.eu">http://www.wdstore.eu</a>
All others	Contact WD Technical Support in your region. For a list of Technical Support contacts, visit <a href="http://support.wdc.com">http://support.wdc.com</a> and see Knowledge Base answer ID 1048.

## Operating System Compatibility

Your My Book VelociRaptor Duo dual-drive storage device and WD Drive Utilities software are compatible with the following Mac OS X 10.6.8 or later operating systems on Thunderbolt technology-enabled computers:

- Snow Leopard
- Lion
- Mountain Lion

Compatibility can vary, depending on hardware configuration and operating system.

For highest performance and reliability, always install the latest software update. Go to the **Apple** menu and select **Software Update**.

## Disk Drive Formats

Your My Book VelociRaptor Duo dual-drive storage device is initially formatted with HFS+J partitions and configured as a striped RAID disk array (RAID 0).

In the RAID configurations, both drives are formatted with a single HFS+J partition for Mac OS X operating systems. In the JBOD configuration, each drive can be reformatted as either:

- HFS+J for Mac computers
- exFAT for running Windows operating systems on Mac computers

*Note:* Older Windows operating systems might need a patch from Microsoft to recognize the exFAT format. (See <http://support.microsoft.com/?kbid=955704>.)

## Physical Description

As shown in Figure 2, the My Book VelociRaptor Duo dual-drive storage device has:

- A power/activity LED indicator on the front
- The power connector, Thunderbolt ports, and a security slot on the back

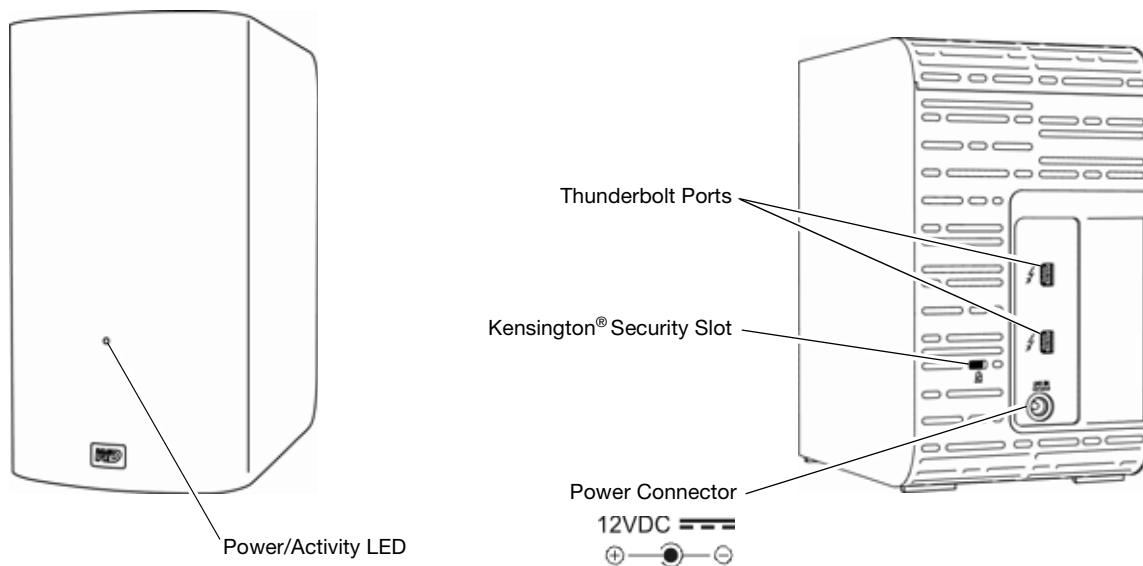

Figure 2. My Book VelociRaptor Duo Dual-drive Storage Device

## Power/Activity LED

The power/activity LED shows the device's normal power state and activity, and provides caution/warning indications as follows:

LED Appearance	Power State/Activity
<b>Normal Operating Indications</b>	
Brief fast-flash display of white-amber-white-amber-white-amber-off, less than one second in duration	Initial power-on sequence
White, on steady	Ready, interface enabled, but idle
White, continuous fast flashing, approximately four times per second	Active
Off	No power, no interface connection, or sleep status
<b>Caution/Warning Indications</b>	
Amber, on steady	Fan failure or over-/under-temperature condition
Amber, slow flashing, approximately two times per second, every other second	At or above critical temperature

*Note:* If you see an over-temperature indication, power down the device and let it cool for 60 minutes. Power it back on, and if the problem persists, contact WD Support.



## Thunderbolt Ports

As shown in Figure 2 on page 4, the My Book VelociRaptor Duo dual-drive storage device has two dual-channel Thunderbolt ports that provide a fast, flexible interface for:

- **Performance**—Thunderbolt technology delivers unprecedented data transfer rates thanks to its revolutionary bidirectional I/O throughput. Each Thunderbolt port provides two bidirectional channels, each with theoretically up to 10 Gb/s of bandwidth.
- **Simplicity**—Thunderbolt technology supports daisy chaining multiple devices through a single Thunderbolt connector so you can multitask at Thunderbolt technology speed without having to use a switch or hub. This reduces the hardware clutter and increases productivity.
- **Flexibility**—Connect additional Thunderbolt technology-enabled external hard drives, media players, HD displays, media capture and editing systems and more through a single connector.

*Note:* Your My Book VelociRaptor Duo device must be connected to a Mac computer that supports Thunderbolt technology. For information about cables that support Thunderbolt technology, visit <http://support.wdc.com>.

## Kensington® Security Slot

For physical device security, the Kensington security slot accepts a standard Kensington security cable (sold separately). For more information about the Kensington security slot and available products, visit <http://www.kensington.com>.

## Registering Your Device

Always register your My Book VelociRaptor Duo dual-drive storage device to get the latest updates and special offers. You can easily register your device using the WD Drive Utilities software, as described in “Registering the Device” on page 18. Another way is to register online at <http://register.wdc.com>.

## Handling Precautions

WD products are precision instruments and must be handled with care during unpacking and installation. Drives can be damaged by rough handling, shock, or vibration. Observe the following precautions when unpacking and using your external storage product:

- Do not drop or jolt the device.
- Do not move the device during power on state.
- Do not operate the device in any position other than the standing upright position.
- Do not use this product as a portable device.
- Do not place the device on carpeting. Make sure the device is on a clean, firm, and stable surface.
- To allow proper ventilation, do not block any of the enclosure’s air slots.

2

## Connecting the Device and Getting Started

This chapter provides instructions for:

- [Connecting the Device](#)
- [Installing the WD Drive Utilities Software](#)

### Connecting the Device

1. Depending on your region, if required, change the AC adapter as follows:

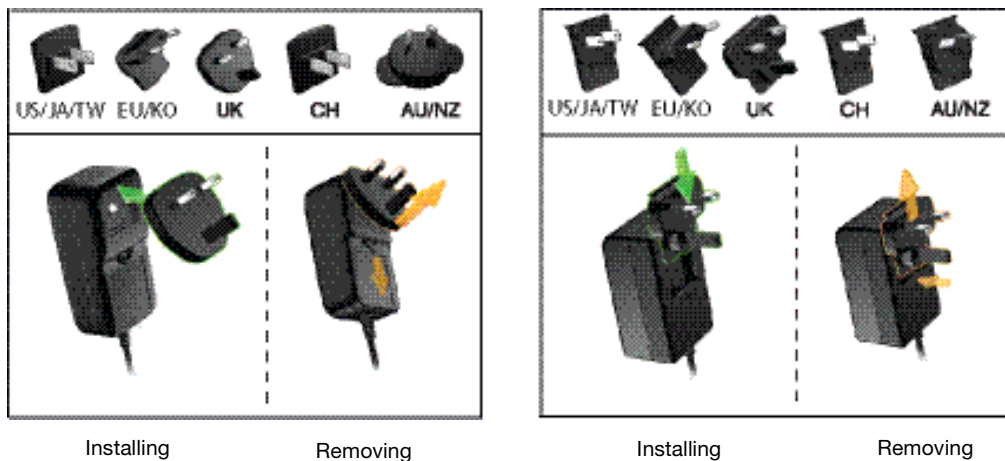

2. Turn on your computer.
3. Connect the AC adapter to a power receptacle and to the 12 VDC power connector on the device:

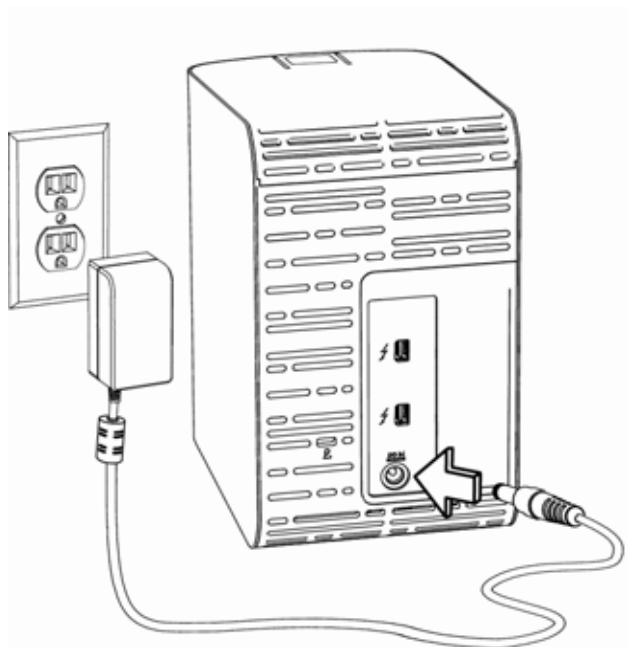

4. Use the Thunderbolt cable to connect either port on the device to your computer:

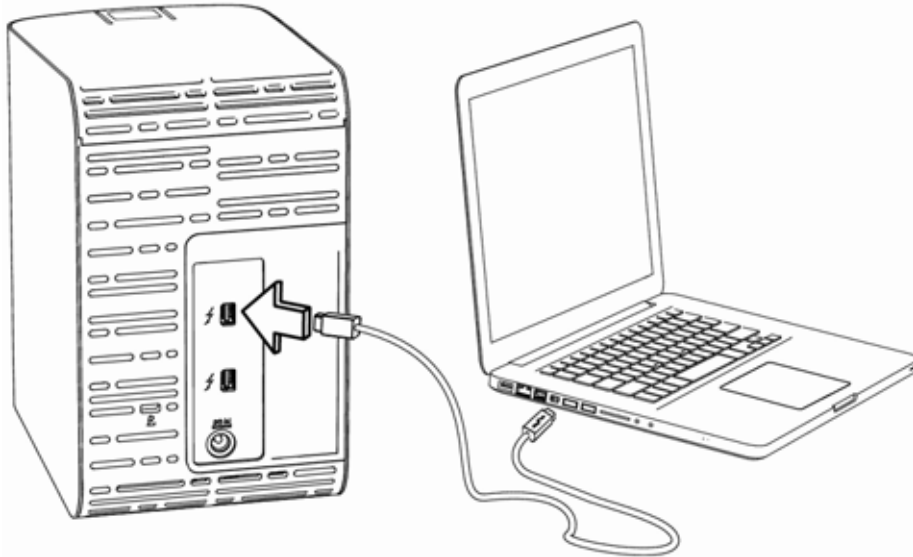

5. Use the other port on the device to connect additional Thunderbolt peripherals.

*Note:* Thunderbolt technology supports a total of seven devices—your computer and up to six external devices.

6. The device automatically powers up and mounts to your computer.
7. Verify that the My Book VelociRaptor Duo appears under DEVICES in the Sidebar area of your Finder display:

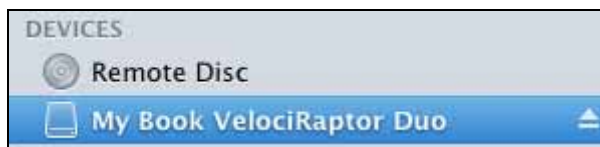

*Note:* If the **External disks** check box is selected on your Finder Preferences dialog, the My Book VelociRaptor Duo icon displays on your desktop:

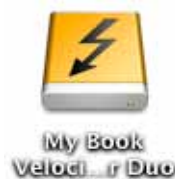

8. The first time you connect the device to your computer, a message asks if you want to use the device drives to back up with Time Machine:

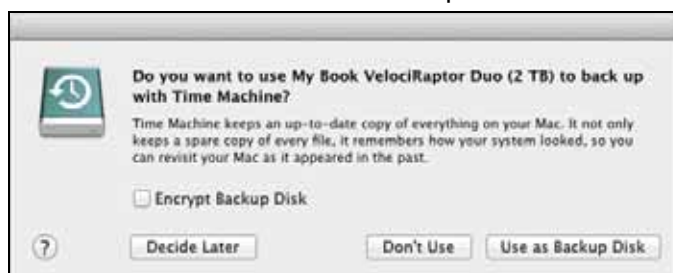

*Note:* Currently the **Encrypt Backup Disk** check box only appears on computers using the Lion or Mountain Lion operating system. DO NOT select this check box. Your My Book VelociRaptor Duo device leverages the operating system to enable

RAID configurations. The Stripe and Mirror RAID modes of your My Book VelociRaptor Duo device are software configured, and the backup disk encryption feature is not compatible with software-configured RAID devices.

If you want to use your device as a backup device with Time Machine on Lion or Mountain Lion, you can either:

- Use it in the default striped RAID configuration *without* backup encryption.
- Convert it to a mirrored RAID configuration and use it *without* backup encryption.
- Convert it to individual drives and use one of them *with* or *without* backup encryption.

(See “Changing the Device Configuration” on page 13.)

- If you *do not* want to use the Time Machine backup software, or if you want to change the drive configuration and then set up Time Machine backups, click:
  - **Don't Use** on Lion or Mountain Lion
  - **Cancel** on Snow Leopard
- If you *do* want to use the Time Machine backup software, click **Use as Backup Disk**.

Either way, your My Book VelociRaptor Duo dual-drive storage device is ready to use. To manage and customize the device for the best possible performance, install the WD Drive Utilities software.

## Installing the WD Drive Utilities Software

1. Double-click either the My Book VelociRaptor Duo Finder listing or its desktop icon, and then double-click the .dmg file on the screen that displays:

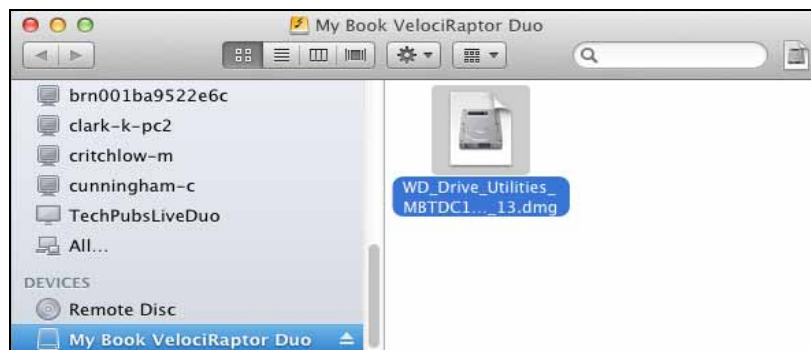

2. Drag the icon for the WD Drive Utilities software to the alias Applications folder on the screen that displays:



3. In the alias Applications folder, double-click the WD Drive Utilities application.
4. Read the license agreement and click **Accept** to continue and display the WD Drive Utilities screen (see Figure 3 below and “Managing and Customizing the Device” on page 10).

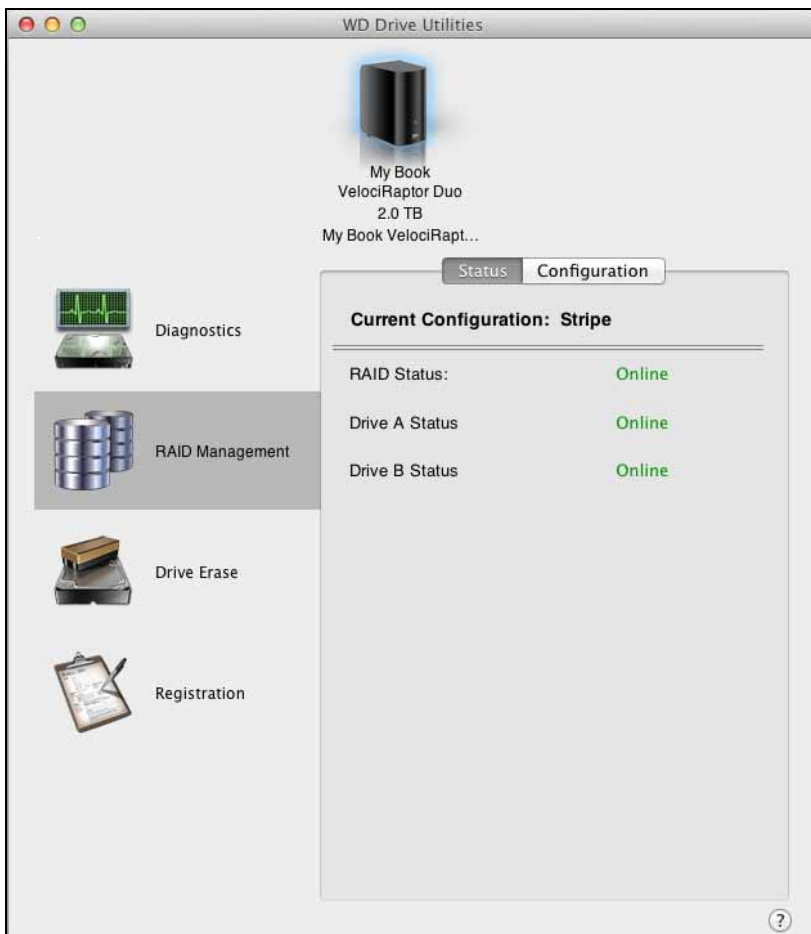

Figure 3. WD Drive Utilities Screen

## 3

## Managing and Customizing the Device

This chapter includes the following topics:

- [Checking Device Health](#)
- [Managing the RAID Configuration](#)
- [Erasing the Device Drives](#)
- [Registering the Device](#)
- [Restoring the WD Software and Disk Image](#)
- [Safely Dismounting the Device Drives](#)

The WD Drive Utilities software makes it easy for you to manage and customize your device for the best possible performance:

- **Diagnostics**—Run diagnostics and status checks to make sure your device drives are working properly.
- **RAID Management**—Check the operational status or change the device drive configuration.
- **Drive Erase**—Erase all of the data on the drives.
- **Registration**—Register your device to receive free technical support during the warranty period and find out about software updates, product enhancements, and price discount opportunities.

On the WD Drive Utilities screen Figure 3 on page 9:

IF you want to . . .	THEN click . . .	AND see . . .
Run drive diagnostics and status checks,	<b>Diagnostics</b>	“Checking Device Health” in the next section.
Check the RAID status or change the configuration of the device drives,	<b>RAID Management</b>	“Managing the RAID Configuration” on page 12
Erase the drives so you can retrieve the space and start over,	<b>Drive Erase</b>	“Erasing the Device Drives” on page 16.
Register the device to receive free technical support during the warranty period and keep up-to-date on the latest WD products,	<b>Registration</b>	“Registering the Device” on page 18.

### Checking Device Health

The WD Drive Utilities software provides three diagnostic tools to help make sure that your device is performing well. Run the following tests if you are concerned that your device is not operating properly:

- **S.M.A.R.T. Status Check**

S.M.A.R.T. is a failure-prediction function that continuously monitors key internal performance attributes of the device drives. A detected increase in drive temperature, noise, or read/write errors, for example, can provide an indication that the drive is approaching a serious failure condition. With advanced warning, you could take precautionary measures, like moving your data to another device, before a failure occurs.

The result of a S.M.A.R.T. status check is a pass or fail evaluation of the drives' condition.

- Quick Drive Test

Each device drive has a built-in Data Lifeguard™ diagnostic utility that tests the drive for error conditions. The quick drive test checks the drives for major performance problems.

The result of a quick drive test is a pass or fail evaluation of the drives' condition.

- Complete Drive Test

The most comprehensive drive diagnostic is the complete drive test. It checks every sector for error conditions, and inserts bad sector markers as required.

The best time to run the drive diagnostics and status checks is on a regular basis, before you encounter any problems with your drives. And, because they are so fast, running the S.M.A.R.T. status check and the quick drive test provides a high level of assurance with minimal inconvenience. Then, run all three whenever you encounter disk error conditions when writing or accessing files.

To run drive diagnostics and status checks:

1. Click **Go > Applications > WD Drive Utilities** to display the WD Drive Utilities screen (see Figure 3 on page 9).
2. If you have more than one supported drive or storage device connected to your computer, select the one that you want to check.
3. Click **Diagnostics** to display the Diagnostics dialog:

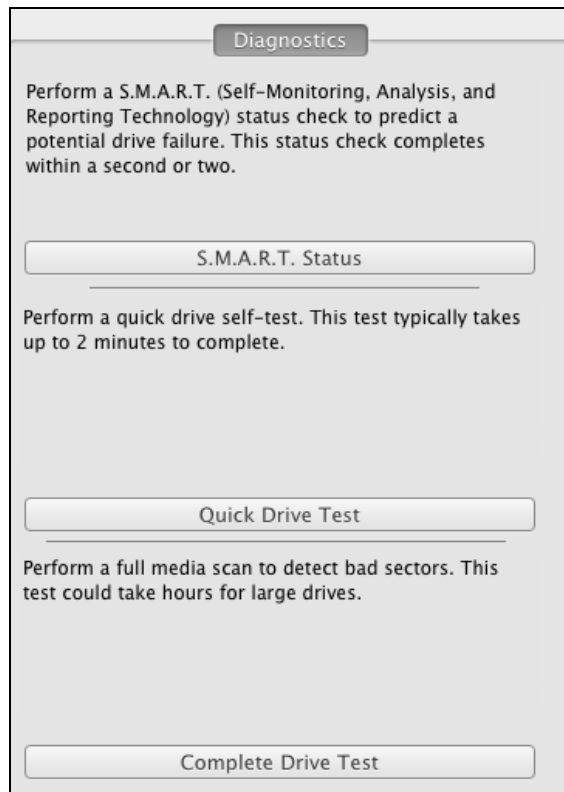

4. On the Diagnostics dialog, click the button for the test that you want to run:
  - **S.M.A.R.T. Status**
  - **Quick Drive Test**
  - **Complete Drive Test**

## Managing the RAID Configuration

The initial/default configuration of your My Book VelociRaptor Duo device is as a striped RAID 0 disk array for high-speed/maximum-storage performance. You can reconfigure the device as either:

- A mirrored RAID 1 disk array for maximum-protection/reduced-storage
- JBOD individual drives that can be formatted differently for enhanced flexibility

## Checking the Device Status

The WD Drive Utilities software provides a status indication of the device configuration and each device drive.

To check the device status:

1. Click **Go > Applications > WD Drive Utilities** to display the WD Drive Utilities screen (see Figure 3 on page 9).
2. If you have more than one supported storage device connected to your computer, select the one that you want to check.
3. Click **RAID Management > Status** to display the device status:

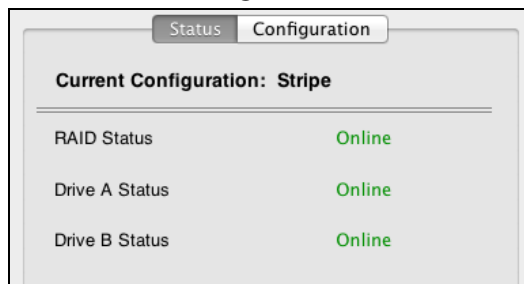

4. The status display shows:
  - Current Configuration as either:
    - Stripe
    - Mirror
    - Individual Drives
  - RAID Status as either:
    - Online
    - Offline
    - Degraded
    - Failed
  - For RAID configurations, Drive A and Drive B Status as either:
    - Online—The drive is online and available
    - Failed—The drive has failed
    - Removed—The drive has been removed
    - Standby—The drive is part of the RAID array but needs to be rebuilt
    - Rebuilding—The drive is being rebuilt
    - Unknown—The drive has some other undetermined status



## Changing the Device Configuration

**CAUTION! Changing the device configuration reformats both drives, which erases all of the data on them. If you have been using the device in one mode and then want to switch to a different mode, back up your files to another storage device before changing the configuration.**

*Note:* Changing the device configuration also deletes the WD software and all of the support files, utilities, and user manual files. You can download these to restore the device to its original configuration after the change. (See Knowledge Base answer ID 7 at <http://support.wdc.com> for information about downloading and restoring the WD software and disk image.)

To change the device configuration:

1. Click **Go > Applications > WD Drive Utilities** to display the WD Drive Utilities screen (see Figure 3 on page 9).
2. If you have more than one supported storage device connected to your computer, select the one that you want to configure.
3. Click **RAID Management > Configuration** to display the Configuration dialog:

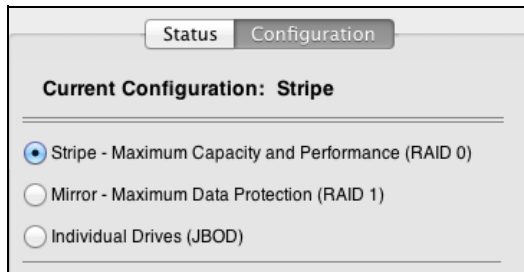

4. Select the option for the mode that you want to change to:
  - **Stripe - Maximum Capacity and Performance (RAID 0)**
  - **Mirror - Maximum Data Protection (RAID 1)**
  - **Individual Drives (JBOD)**

Selecting the . . . option	Displays a volume dialog for specifying the . . .
Stripe or Mirror  Note that the exFAT (extended File Allocation Table) format is not RAID configurable.	Volume name for the new RAID array:  
Individual Drives	Volume name and file format for each drive:  

5. On the volume dialog:
  - a. If you want to change the name of a volume, type over the name in the **Volume Name** box.
  - b. If you are converting to individual drives, select the option to specify the file format for each volume:
    - **HFS+J**
    - **ExFAT**
  - c. Read the warning about the loss of data when you change the device configuration and select the **I understand** check box to signify that you accept the risk and activate the **Configure** button:

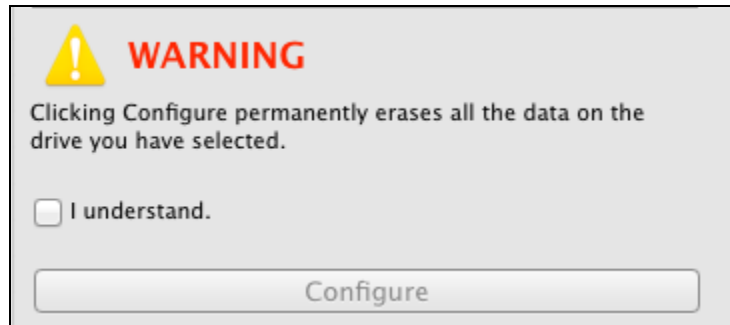

**Important:** If you want to save any of the data that is on the device drives, back it up to another storage device before continuing with the configuration change.

- d. Click **Configure** to begin the configuration change.
6. When prompted, type your password and click **OK** to continue:



7. During the configuration change, the WD Drive Utilities software:
  - Displays a status bar to show the progress of the conversion
  - Clears and then redisplayes the Finder listing and desktop icon display to support the new device mode

8. The first time you configure to a new volume, a message asks if you want to use the device drives to back up with Time Machine:

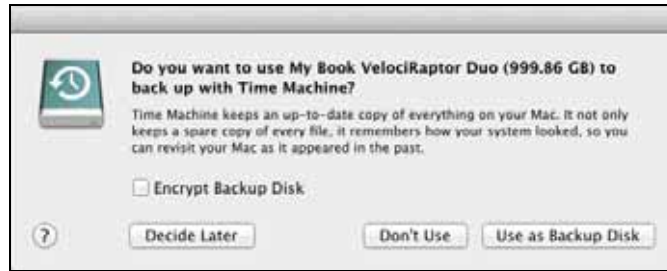

New Mirror Volume

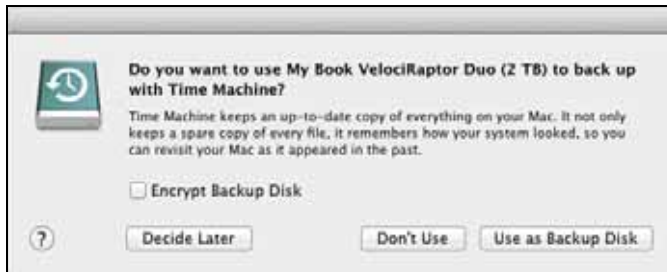

New Stripe Volume



New Individual Drives Volumes

*Note:* Currently the **Encrypt Backup Disk** check box only appears on computers using the Lion or Mountain Lion operating system. DO NOT select this check box if you have converted to a RAID volume. Your My Book VelociRaptor Duo device leverages the operating system to enable RAID configurations. The Stripe and Mirror RAID modes of your My Book VelociRaptor Duo device are software configured, and the backup disk encryption feature is not compatible with software-configured RAID devices.

- If you *do not* want to use the Time Machine backup software, click:
    - **Don't Use** on Lion or Mountain Lion
    - **Cancel** on Snow Leopard
 Skip to step 10 on page 16.
  - If you *do* want to use the Time Machine backup software, then for:
    - A stripe or mirror RAID volume, click **Use as Backup Disk** and skip to step 10 on page 16.
    - Individual drives volumes, proceed to step 9.
9. To use JBOD mode as a backup disk with Time Machine in HFS+J only:
- a. Select the volume that you want to use:
    - **My Book VelociRaptor Duo - A**
    - **My Book VelociRaptor Duo - B**

- b. Depending on your computer's operating system:
- Using Snow Leopard, click **Use as Backup Disk** and skip to step 10.
  - Using Lion or Mountain Lion:
    - If you want to create a password to secure your backup files, select the **Encrypt Backup Disk** check box and proceed to step c.
    - If you do not want to create a password to encrypt your backup files, click **Use as Backup Disk** and skip to step 10.
- c. Click **Use as Backup Disk** and complete the backup password dialog that displays:



- d. Click **Encrypt Disk** and proceed to step 10.

10. After the configuration change completes, click **OK** to close the completion message display:

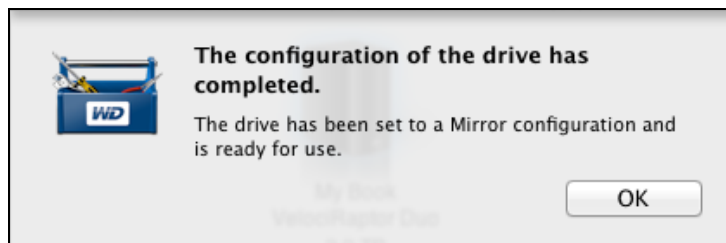

*Note:* The completion message changes to reflect the mode you have changed to.

11. Go to <http://support.wdc.com> and see Knowledge Base answer ID 7 for information about downloading and restoring the WD software and disk image.

## Erasing the Device Drives

**CAUTION! Erasing a drive permanently deletes all of the data on the drive. Always back up the data on the drive before erasing it.**

*Note:* Erasing your device drives also deletes the WD software and all of the support files, utilities, and user manual files. You can download these to restore your device to its original configuration after erasing the drives. (See Knowledge Base answer ID 7 at <http://support.wdc.com> for information about downloading and restoring the WD software and disk image.)

To erase your My Book VelociRaptor Duo device drives:

1. Click **Go > Applications > WD Drive Utilities** to display the WD Drive Utilities screen (see Figure 3 on page 9).

2. If you have more than one supported storage device or drive connected to your computer, select the one that you want to erase.
3. Click **Drive Erase** to display the Drive Erase dialog:

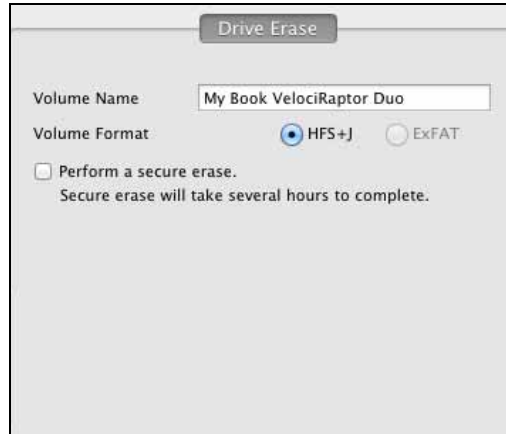

For RAID Array Configurations

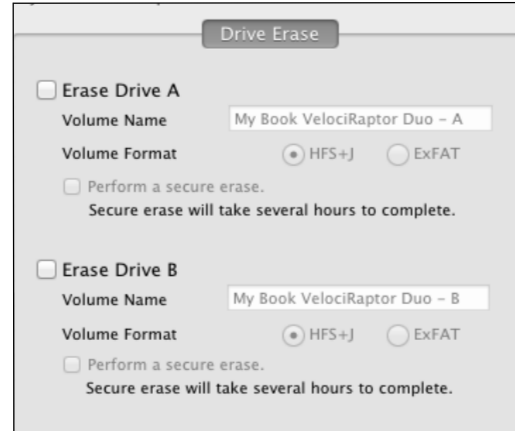

For Individual Drives

4. On the Drive Erase dialog:
  - a. For individual drives, select the check box for each drive that you want to erase:
    - **Erase Drive A**
    - **Erase Drive B**
  - b. If you want to perform a secure erase operation on a drive, select its **Perform a secure erase** check box.

*Note:* Selecting this option ensures all data on the device is erased. This will take several hours to complete. If you do not select this option, the WD Drive Utilities software performs a quick erase operation and the data might be recoverable using disk recovery software.

- c. If you want to change the name of a volume, type over the name in the **Volume Name** box.
- d. For individual drives, select the option to specify the file format for each volume:
  - **HFS+J**
  - **ExFAT**

Note that the exFAT (extended File Allocation Table) format is not RAID configurable.

- e. Read the warning about the loss of data when you erase the drive and select the **I understand** check box to signify that you accept the risk and activate the **Erase Drive** button:



**Important:** If you want to save any of the data that is on the device drives, back it up to another device before continuing with the drive erase.

- f. Click **Erase Drive** to begin the erase operation.
5. When prompted, type your password and click **OK** to continue:



6. After the drive erase operation completes, click **OK** to close the completion message display:

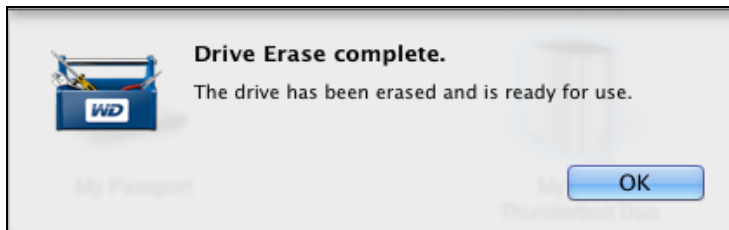

7. Go to <http://support.wdc.com> and see Knowledge Base answer ID 7 for information about downloading and restoring the WD software and disk image.

## Registering the Device

The WD Drive Utilities software uses your computer's Internet connection to register your device. Registering the device provides free technical support during the warranty period and keeps you up-to-date on the latest WD products.

To register your device:

1. Make sure that your computer is connected to the Internet.
2. Click **Go > Applications > WD Drive Utilities** to display the WD Drive Utilities screen (see Figure 3 on page 9).
3. If you have more than one supported storage device or drive connected to your computer, select the one that you want to register.

4. Click **Registration** to display the Registration dialog:

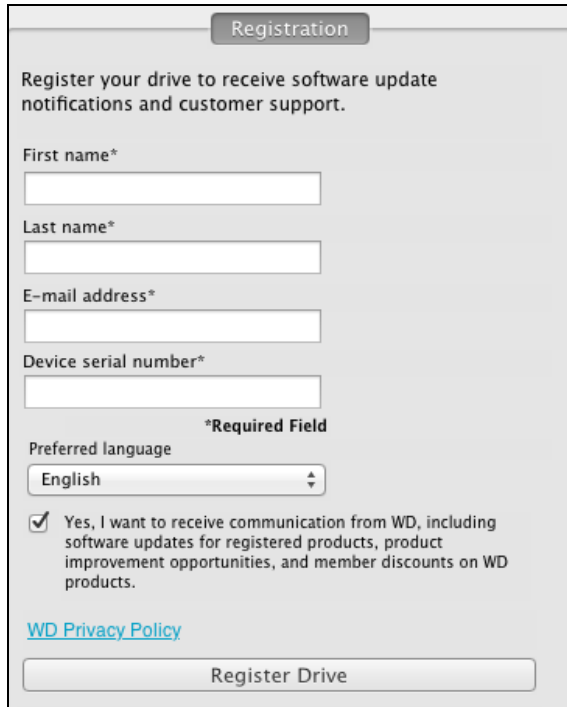

The image shows a registration dialog box with the following fields and options:

- Registration** (Title)
- Register your drive to receive software update notifications and customer support.
- First name\* (Text input field)
- Last name\* (Text input field)
- E-mail address\* (Text input field)
- Device serial number\* (Text input field)
- \*Required Field
- Preferred language (Dropdown menu showing "English")
- Yes, I want to receive communication from WD, including software updates for registered products, product improvement opportunities, and member discounts on WD products.
- [WD Privacy Policy](#)
- Register Drive (Button)

5. On the Registration dialog:
- Type your first name in the **First name** box.
  - Type your last name in the **Last name** box.
  - Type your email address in the **E-mail address** box.
  - Type the serial number of your My Book VelociRaptor Duo device in the **Device serial number** box.
  - Select your language in the **Preferred language** box.
  - Select or clear the **Yes, I want to receive communication...** check box to specify whether you want to receive notifications about software updates, product enhancements, and price discount opportunities.
  - Click **Register Drive**.

## Restoring the WD Software and Disk Image

In addition to deleting all of the data on your device, erasing or reformatting the device drives also removes the WD Drive Utilities software and all of the support files, utilities, and user manual files.

If you ever need to remove and reinstall the WD software on your computer, or move the device to another computer and install the software there, you will need to restore the WD software and disk image on your device drives. To do this, after you have erased or reformatted the drives, go to <http://support.wdc.com> and see Knowledge Base answer ID 7.

## Safely Dismounting the Device Drives

**CAUTION! To prevent data loss, close all active windows and applications before shutting down or disconnecting the device drives.**

Use the My Book VelociRaptor Duo Finder listing or desktop icon to safely dismount the device drives:

1. Right- or control-click the My Book VelociRaptor Duo Finder listing or desktop icon and select **Eject "My Book VelociRaptor Duo"**:

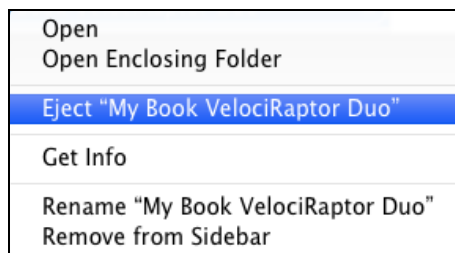

Finder Listing Display

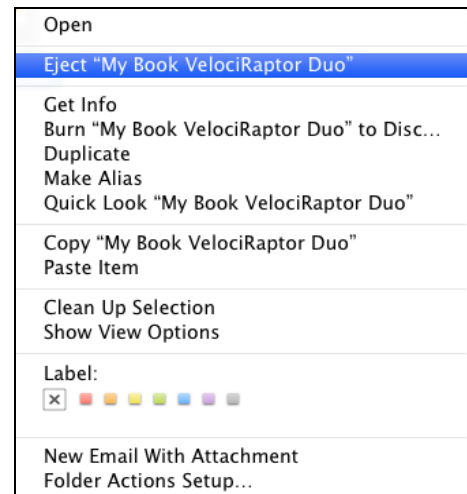

Desktop Icon Display

2. If you have converted your device to individual drives, eject both the A and B volumes.  
You might hear the drives power down.
3. Wait for the Finder listing or desktop icon to disappear before disconnecting the device.



## 4

## Replacing a Drive

This chapter includes the following topics:

- [Determining Which Drive Failed](#)
- [Contacting WD Technical Support](#)
- [Removing and Replacing the Drive](#)

### Determining Which Drive Failed

Whether the application is running or not, the WD Drive Utilities software continuously monitors the operational condition of your My Book VelociRaptor Duo drives. When a drive fails, the utility displays a warning message, depending on the configuration of your system:

For a striped RAID 0 configuration:



For a mirrored RAID 1 configuration:



For an individual drives JBOD configuration:

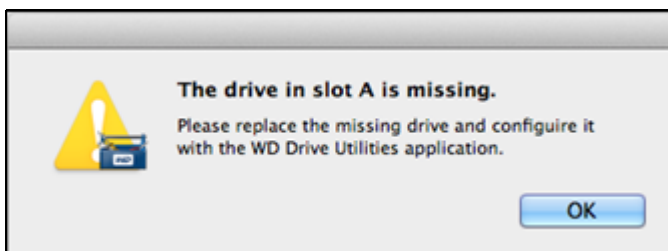

As prompted for a RAID configuration, use the WD Drive Utilities software to determine which drive has failed. (See "Checking the Device Status" on page 12.)

For a JBOD configuration, the warning message indicates the drive that failed.

## Contacting WD Technical Support

After you have determined which drive has failed, go to <http://support.wdc.com> and see Knowledge Base answer ID 8644 for information about obtaining a replacement drive. When contacting Technical Support, have the following information ready:

- The serial number of your My Book VelociRaptor Duo device
  - Date of purchase
  - The serial number of each internal hard drive you need to replace
- See steps 1 through 8 of the following procedure for removing the drive to see the serial number.

## Removing and Replacing the Drive

Your My Book VelociRaptor Duo dual-drive storage device is a limited user-serviceable device. You can easily replace the hard drives inside the enclosure.

---

**Important:** Only use WD VelociRaptor® hard drive assemblies to replace the drives in your My Book VelociRaptor Duo device enclosure. Using any other hard drive assembly voids the warranty for your My Book VelociRaptor Duo device.

---

After receiving the replacement drive, replace the failed drive as follows:

1. If the device is still operational, safely dismount the drives from your computer.
- 
2. **Important:** To avoid electrostatic discharge (ESD) damage, ground yourself by touching a grounded metal object before handling the device.
- 
3. Disconnect the Thunderbolt cables from the Thunderbolt ports on the back of the device enclosure.
  4. Disconnect the AC adapter cable from the power connector.
  5. Place the device on a clean and stable surface.
  6. Firmly push down on the top cover button to release the latch and open the top cover:

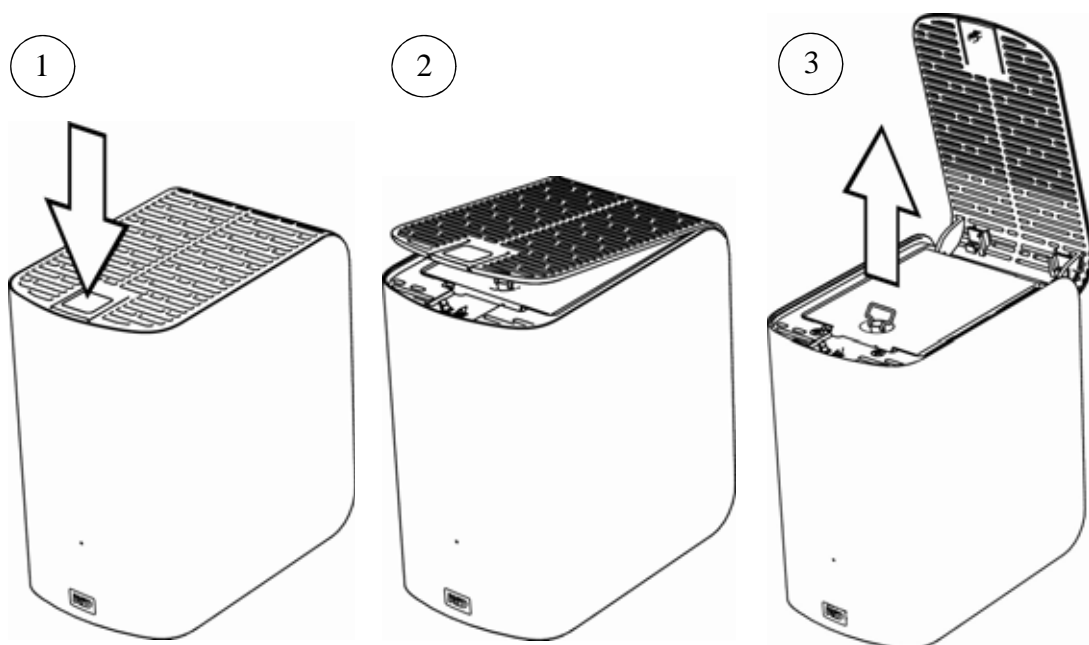

7. Lift and loosen the thumbscrew that secures the drive cover plate and remove the plate:

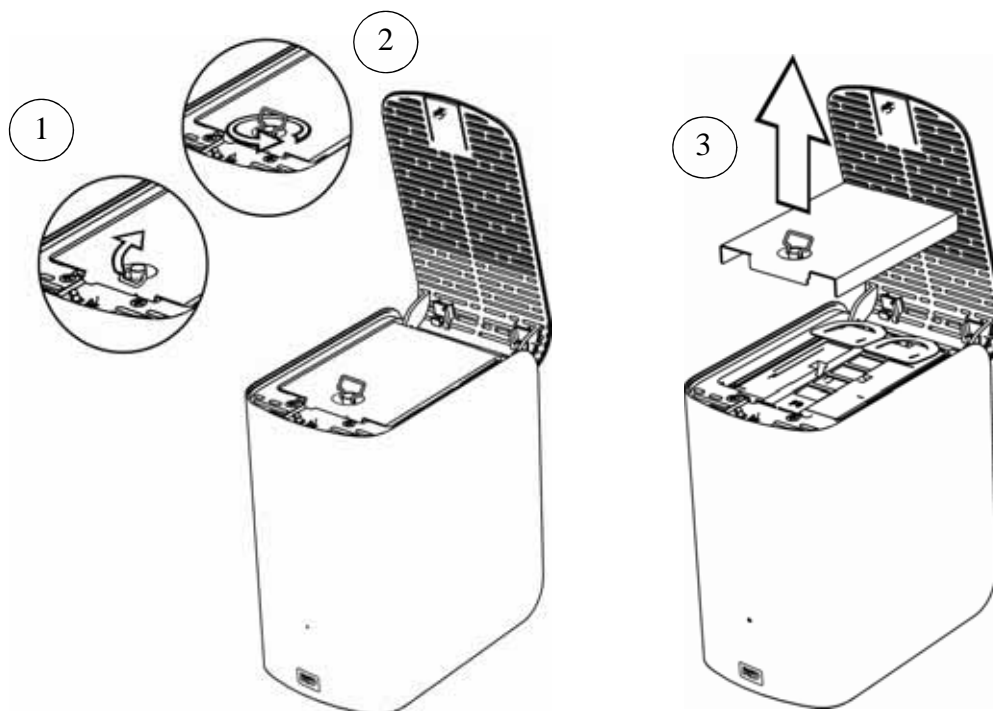

8. Using the pull tab, carefully lift the faulty drive out of the enclosure:

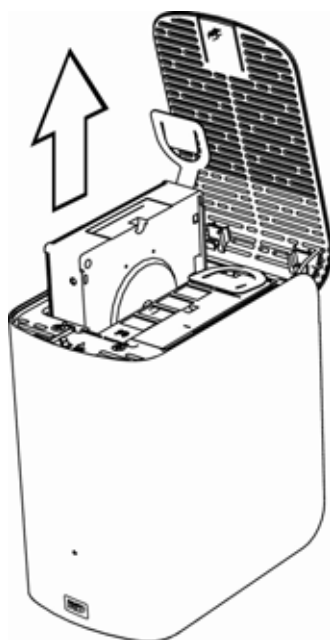

*Note:* Though the drives are labeled Drive A and Drive B, it is their enclosure locations that determine the drive designations used by the WD Drive Utilities software. As you view them from the front of the enclosure:

The drive in the . . . enclosure slot	Is drive . . .
Left	A
Right	B

Switching the drives from one enclosure slot to the other would have no impact on the operation of your My Book VelociRaptor Duo device or the WD Drive Utilities software. If you do that, just remember that regardless of the label on the drive, the status and configuration of:

- “Drive A” refers to the drive in the left enclosure slot
- “Drive B” refers to the drive in the right enclosure slot

9. Gently slide the replacement drive assembly into the enclosure until it is fully inserted:

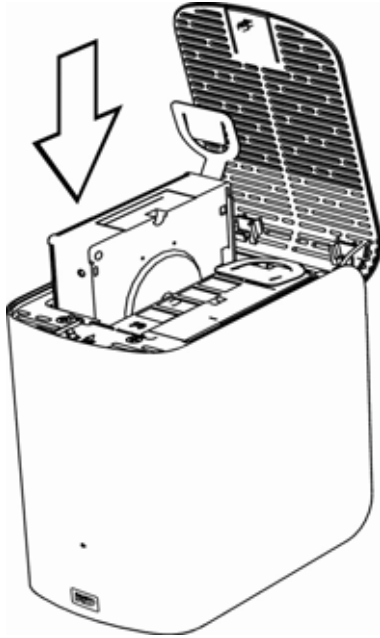

10. Replace the drive cover plate and secure it with the thumbscrew:

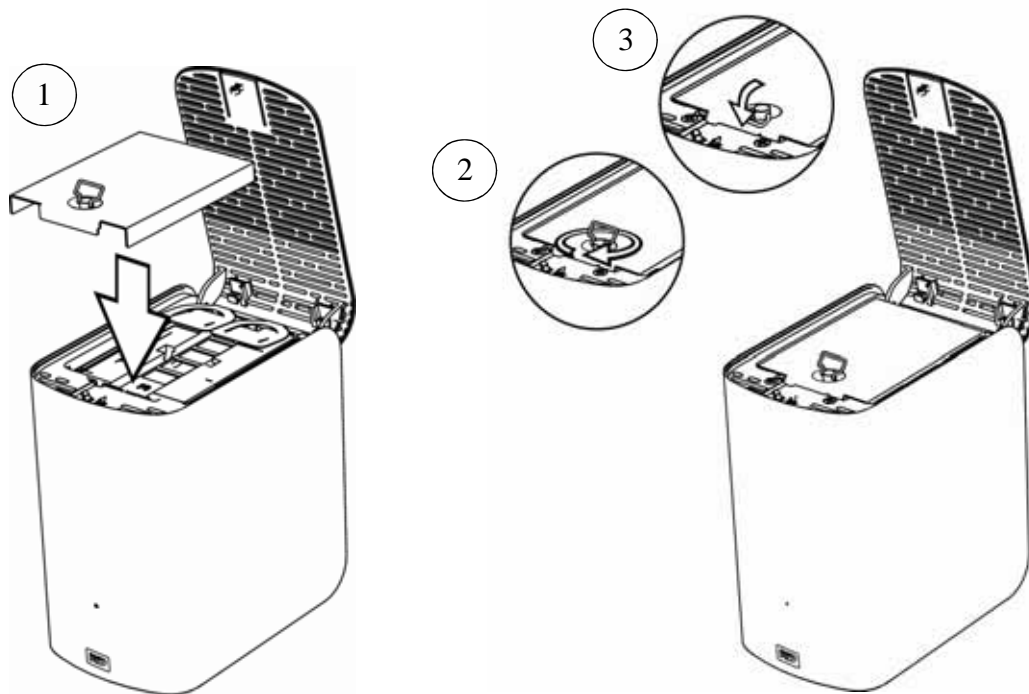

*Note:* Do not overtighten the thumbscrew.

11. Close the top cover and firmly push down on the top cover button until it snaps into place:

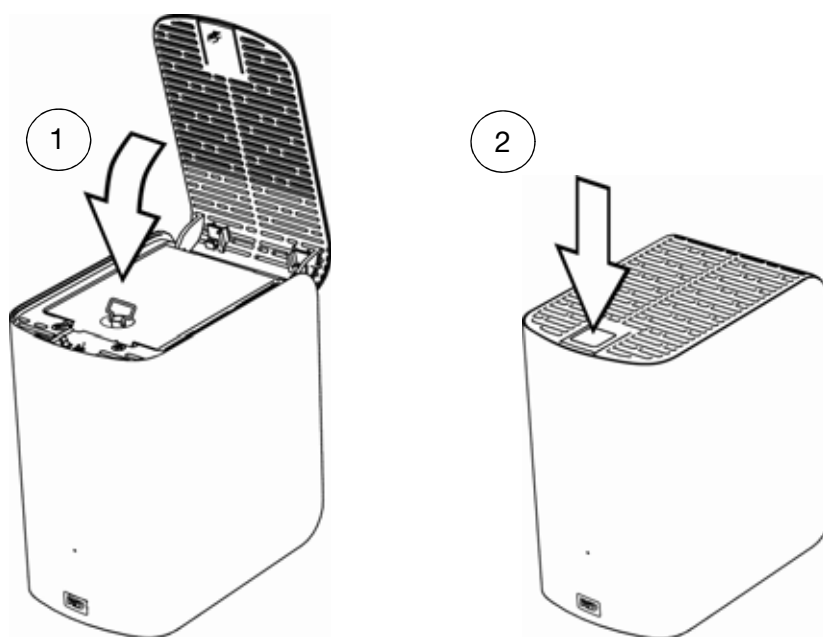

12. If the WD Drive Utilities software is not already running, click **Go > Applications > WD Drive Utilities** to display the WD Drive Utilities screen (see Figure 3 on page 9).
13. Reconnect the AC adapter cable to the power connector on the back of the device enclosure.
14. Reconnect the Thunderbolt cables.
15. Depending on the configuration of your device:

If your device is configured as . . .	THEN . . .
A striped RAID 0 disk array	<p>The Finder listing and desktop icon for your My Book VelociRaptor Duo device <i>do not</i> reappear. In this case:</p> <ol style="list-style-type: none"> <li>a. If you have more than one supported device connected to your computer, select the one with the drive you replaced on the WD Drive Utilities screen and click <b>RAID Management &gt; Status</b> to display the device status.</li> <li>b. Verify that the status display shows: <ul style="list-style-type: none"> <li>• Current Configuration - Stripe</li> <li>• RAID Status - Offline</li> <li>• Drive A Status and Drive B Status - Unknown for the drive that you replaced and Online for the other drive</li> </ul> </li> </ol> <p>This indication means that you must reconfigure your striped RAID 0 disk array.</p>

(Continued)

If your device is configured as . . .	THEN . . .
A striped RAID 0 disk array (continued)	<p>c. Click <b>Configuration</b> to display the volume dialog for reconfiguring the RAID array.</p> <p>d. Use the device configuration procedure in “Changing the Device Configuration,” starting at step 5 on page 14 to reconfigure the striped RAID 0 disk array.</p> <p>e. When the reconfiguration completes, the Finder listing and desktop icon for your My Book VelociRaptor Duo device reappear.</p> <p>f. Click <b>Status</b> and verify that the status display shows:</p> <ul style="list-style-type: none"> <li>• Current Configuration - Stripe</li> <li>• RAID Status - Online</li> <li>• Drive A Status - Online</li> <li>• Drive B Status - Online</li> </ul> <p>Your device is ready to use.</p>
A mirrored RAID 1 disk array	<p>a. Verify that the Finder listing and desktop icon for your My Book VelociRaptor Duo device reappear.</p> <p>b. If you have more than one supported device connected to your computer, select the one with the drive you replaced on the WD Drive Utilities screen and click <b>RAID Management &gt; Status</b> to display the device status.</p> <p>c. Verify that the status display shows:</p> <ul style="list-style-type: none"> <li>• Current Configuration - Mirror</li> <li>• RAID Status - Degraded</li> <li>• Drive A Status and Drive B Status - Rebuilding for the drive that you replaced and Online for the other drive</li> </ul> <p>This indication means that the WD Drive Utilities software is rebuilding your mirrored RAID 1 disk array.</p> <p>d. Wait for the rebuild operation to complete. This could take several hours.</p> <p>e. When the rebuild operation completes, the device status display shows:</p> <ul style="list-style-type: none"> <li>• Current Configuration - Mirror</li> <li>• RAID Status - Online</li> <li>• Drive A Status - Online</li> <li>• Drive B Status - Online</li> </ul> <p>Your device is ready to use.</p>

(Continued)

If your device is configured as . . .	THEN . . .
JBOD	<p>a. Verify that the Finder listing and desktop icon for the My Book VelociRaptor Duo drive that you <i>did not</i> replace reappear.</p> <p>The Finder listing and desktop icon for the new/replacement drive do not appear because you have to format it using the WD Drive Utilities Drive Erase function.</p> <p>b. If you have more than one supported device connected to your computer, select the one with the drive you replaced on the WD Drive Utilities screen and click <b>Drive Erase</b> to display the Drive Erase dialog.</p> <p>c. Use the drive erase procedure in “Erasing the Device Drives,” starting at step 4 on page 17 to erase/reformat the replacement drive.</p> <p><b>CAUTION! Make sure you select the check box for the <i>replacement</i> drive.</b></p> <p>d. When the erase/reformat operation completes, verify that the Finder listing and desktop icon for the replacement drive reappear.</p> <p>Your replacement drive is ready to use.</p>

16. Go to <http://support.wdc.com> and see Knowledge Base answer ID:

- 7 for information about downloading and restoring the WD software and disk image
- 8644 for information about returning the defective drive.

---

**Important:** Do not disassemble the internal drive and attached assembly components. Return the entire internal drive assembly intact to WD.

---

**A**

## Compliance and Warranty Information

This appendix includes the following topics:

- [Regulatory Compliance](#)
- [Environmental Compliance \(China\)](#)
- [Warranty Information \(All Regions Except Australia/New Zealand\)](#)
- [Warranty Information \(Australia/New Zealand\)](#)
- [GNU General Public License \(“GPL”\)](#)

### Regulatory Compliance

#### FCC Class B Information

This device has been tested and found to comply with the limits of a Class B digital device, pursuant to Part 15 of the FCC Rules. These limits are designed to provide reasonable protection against harmful interference in a residential installation. This unit generates, uses, and can radiate radio frequency energy and, if not installed and used in accordance with the instructions, may cause harmful interference to radio or television reception. However, there is no guarantee that interference will not occur in a particular installation. Any changes or modifications not expressly approved by WD could void the user's authority to operate this equipment.

#### ICES/NMB-003 Compliance

Cet appareil de la classe B est conforme à la norme NMB-003 du Canada.

This device complies with Canadian ICES-003 Class B.

#### Safety Compliance

Approved for US and Canada. CAN/CSA-C22.2 No. 60950-1, UL 60950-1: Safety of Information Technology Equipment.

Approuvé pour les Etats-Unis et le Canada. CAN/CSA-C22.2 No. 60950-1: Sûreté d'équipement de technologie de l'information.

This product is intended to be supplied by a listed limited power source, double insulated, or direct plug-in power unit marked “Class 2.”

#### CE Compliance for Europe

Marking by the CE symbol indicates compliance of this system to the applicable Council Directives of the European Union, including the EMC Directive (2004/108/EC) and the Low Voltage Directive (2006/95/EC). A “Declaration of Conformity” in accordance with the applicable directives has been made and is on file at Western Digital Europe.



## GS Mark (Germany only)

Machine noise - regulation 3. GPSGV: Unless declared otherwise, the highest level of sound pressure from this product is 70db(A) or less, per EN ISO 7779.

Maschinenlärminformations-Verordnung 3. GPSGV: Der höchste Schalldruckpegel beträgt 70 db(A) oder weniger gemäß EN ISO 7779, falls nicht anders gekennzeichnet oder spezifiziert.

## KC Notice (Republic of Korea only)

(가 B )	가 (B ) ,

## Environmental Compliance (China)

部件名称	有毒有害物质和元素					
	铅 (Pb)	镉 (Cd)	汞 (Hg)	六价铬 (Cr <sup>6+</sup> )	多溴联苯 (PBB)	多溴二苯醚 (PBDE)
包装页	○	○	○	○	○	○
包装外壳	○	○	○	○	○	○
光导管	○	○	○	○	○	○
电源按钮	○	○	○	○	○	○
HDD 托架	○	○	○	○	○	○
EMI 外壳	○	○	○	○	○	○
个性化板材	○	○	○	○	○	○
Kensington 锁按键	○	○	○	○	○	○
螺丝 6-32x6.35mm	○	○	○	○	○	○
螺丝 M3x5mm+5W	○	○	○	○	○	○
垂直支脚	○	○	○	○	○	○
减震架	○	○	○	○	○	○
印制板装配 (PCA)*	○	○	○	○	○	○
硬盘	X	○	○	○	○	○
电缆组件	○	○	○	○	○	○
电源适配器	○	○	○	○	○	○
电源线	○	○	○	○	○	○

\* 印制板装配包括所有印刷电路板 (PCB) 及其相应的各个组件、IC 及连接器。

○ : 表示此部件所用的所有均质材料中包含的此有毒或有害物低于 MCV 标准中的限制要求。

X : 表示此部件所用的均质材料中至少有一种材料包含的此有毒或有害物高于 MCV 标准中的限制要求。

在出现一个 “X” 的所有情况下, WD 采用容许的排除。

## Warranty Information (All Regions Except Australia/ New Zealand)

### Obtaining Service

WD values your business and always attempts to provide you the very best of service. If this Product requires maintenance, either contact the dealer from whom you originally purchased the Product or visit our product support website at <http://support.wdc.com/warranty/policy.asp> for information on how to obtain service or a Return Material Authorization (RMA). If it is determined that the Product may be defective, you will be given an RMA number and instructions for Product return. An unauthorized return (i.e., one for which an RMA number has not been issued) will be returned to you at your expense. Authorized returns must be shipped in an approved shipping container, prepaid and insured, to the address provided on your return paperwork. Your original box and packaging materials should be kept for storing or shipping your WD product. To conclusively establish the period of warranty, check the warranty expiration (serial number required) via <http://support.wdc.com/warranty/policy.asp>. WD shall have no liability for lost data regardless of the cause, recovery of lost data, or data contained in any Product placed in its possession.

## Limited Warranty

WD warrants that the Product, in the course of its normal use, will for the term defined below, be free from defects in material and workmanship and will conform to WD's specification therefor. The term of your limited warranty depends on the country in which your Product was purchased. The term of your limited warranty is for 3 years in the North, South and Central America region, 3 years in the Europe, the Middle East and Africa region, and 3 years in the Asia Pacific region, unless otherwise required by law. The term of your limited warranty period shall commence on the purchase date appearing on your purchase receipt. WD shall have no liability for any Product returned if WD determines that the Product was stolen from WD or that the asserted defect a) is not present, b) cannot reasonably be rectified because of damage occurring before WD receives the Product, or c) is attributable to misuse, improper installation, alteration (including removing or obliterating labels and opening or removing external enclosures, unless the product is on the list of limited user-serviceable products and the specific alteration is within the scope of the applicable instructions, as found at <http://support.wdc.com/warranty/policy.asp>), accident or mishandling while in the possession of someone other than WD. Subject to the limitations specified above, your sole and exclusive warranty shall be, during the period of warranty specified above and at WD's option, the repair or replacement of the Product.

The foregoing limited warranty is WD's sole warranty and is applicable only to products sold as new. The remedies provided herein are in lieu of a) any and all other remedies and warranties, whether expressed, implied or statutory, including but not limited to, any implied warranty of merchantability or fitness for a particular purpose, and b) any and all obligations and liabilities of WD for damages including, but not limited to accidental, consequential, or special damages, or any financial loss, lost profits or expenses, or lost data arising out of or in connection with the purchase, use, or performance of the Product, even if WD has been advised of the possibility of such damages. In the United States, some states do not allow exclusion or limitations of incidental or consequential damages, so the limitations above may not apply to you. This warranty gives you specific legal rights, and you may also have other rights which vary from state to state.

## Warranty Information (Australia/New Zealand)

Nothing in this warranty modifies or excludes your legal rights under the Australian Competition and Consumer Act or the New Zealand Consumer Guarantees Act. This warranty identifies WD's preferred approach to resolving warranty claims which is likely to be quick and simple for all parties.

No other warranties either express or implied by law, including but not limited to those contained in the Sale of Goods Act, are made with respect to the Product. If you purchased your Product in New Zealand for the purposes of a business, you acknowledge and agree that the New Zealand Consumer Guarantees Act does not apply. In Australia, our goods come with guarantees that cannot be excluded under the Australian Consumer Law. You are entitled to a replacement or refund for a major failure and compensation for any other reasonably foreseeable loss or damage. You are also entitled to have the goods repaired or replaced if goods fail to be of acceptable quality and the failure does not amount to a major failure. What constitutes a major failure is set out in the Australian Consumer Law.

## Obtaining Service

WD values your business and always attempts to provide you the very best of service. Should you encounter any problem, please give us an opportunity to address it before returning this Product. Most technical support questions can be answered through our knowledge base or e-mail support service at <http://support.wdc.com>. If the answer is not available or, if you prefer, please contact WD at the applicable telephone number shown in the front of this document.

If you wish to make a claim, you should initially contact the dealer from whom you originally purchased the Product. If you are unable to contact the dealer from whom you originally purchased the Product, please visit our product support Web site at <http://support.wdc.com> for information on how to obtain service or a Return Material Authorization (RMA). If it is determined that the Product may be defective, you will be given an RMA number and instructions for Product return. An unauthorized return (i.e., one for which an RMA number has not been issued) will be returned to you at your expense. Authorized returns must be shipped in an approved shipping container, prepaid and insured, to the address provided with your RMA number. If following receipt of a qualifying claim under this warranty, WD or the dealer from whom you originally purchased the Product determines that your claim is valid, WD or such dealer shall, at its discretion, either repair or replace the Product with an equivalent or better Product or refund the cost of the Product to you. You are responsible for any expenses associated with a claim under this warranty. The benefits provided to you under this warranty are in addition to other rights and remedies available to you under the Australian Competition and Consumer Act or the New Zealand Consumer Guarantees Act.

Your original box and packaging materials should be kept for storing or shipping your WD product. To conclusively establish the period of warranty, check the warranty expiration (serial number required) via <http://support.wdc.com>.

Western Digital Technologies, Inc.  
3355 Michelson Drive, Suite 100  
Irvine, California 92612  
E-mail: [support@wdc.com](mailto:support@wdc.com)

## Warranty

WD warrants that the Product, in the course of its normal use, will for the term defined below, be free from defects in material and workmanship and will conform to WD's specifications. The term of your warranty is 3 year in Australia and New Zealand, unless otherwise required by law. The term of your warranty period shall commence on the purchase date appearing on your purchase receipt from an authorized distributor or authorized reseller. Proof of purchase shall be required to be eligible for this warranty and to establish the commencement date of this warranty. Warranty service will not be provided unless the Product is returned to an authorized distributor, authorized reseller or regional WD return center where the Product was first shipped by WD. WD may at its discretion make extended warranties available for purchase. WD shall have no liability for any Product returned if WD determines that the Product was (i) not purchased from an authorized distributor or authorized reseller, (ii) not used in accordance with WD specifications and instructions, (iii) not used for its intended function, or (iv) stolen from WD, or that the asserted defect a) is not present, b) cannot reasonably be rectified because of damage occurring before WD receives the Product, or c) is attributable to misuse, improper installation, alteration (including removing or obliterating labels and opening or removing external enclosures, including the mounting frame, unless the

product is on the list of limited user-serviceable products and the specific alteration is within the scope of the applicable instructions, as found at <http://support.wdc.com>), accident or mishandling while in the possession of someone other than WD.

**PRODUCTS ARE COMPLEX AND FRAGILE ITEMS THAT MAY OCCASSIONALLY FAIL DUE TO (A) EXTERNAL CAUSES, INCLUDING WITHOUT LIMITATION, MISHANDLING, EXPOSURE TO HEAT, COLD, AND HUMIDITY, AND POWER FAILURES, OR (B) INTERNAL FAULTS. SUCH FAILURES CAN RESULT IN THE LOSS, CORRUPTION, DELETION OR ALTERATION OF DATA. NOTE THAT YOU SHALL BE RESPONSIBLE FOR THE LOSS, CORRUPTION, DELETION OR ALTERATION OF DATA HOWSOEVER CAUSED, AND FOR BACKING UP AND PROTECTING DATA AGAINST LOSS, CORRUPTION, DELETION OR ALTERATION. YOU AGREE TO CONTINUALLY BACK UP ALL DATA ON THE PRODUCT, AND TO COMPLETE A BACKUP PRIOR TO SEEKING ANY GENERAL SERVICE AND TECHNICAL SUPPORT FROM WD.**

In Australia, if the Product is not of a kind ordinarily acquired for personal, domestic or household use or consumption, provided it is fair and reasonable to do so, WD limits its liability to replacement of the Product or supply of equivalent or better Product.

This warranty shall extend to repaired or replaced Products for the balance of the applicable period of the original warranty or ninety (90) days from the date of shipment of a repaired or replaced Product, whichever is longer. This warranty is WD's sole manufacturer's warranty and is applicable only to Products sold as new.

## **GNU General Public License (“GPL”)**

Firmware incorporated into this product may include third party copyrighted software licensed under the GPL or Lesser General Public License (“LGPL”) (collectively, “GPL Software”) and not Western Digital’s End User License Agreement. In accordance with the GPL, if applicable: 1) the source code for the GPL Software may be downloaded at no charge from <http://support.wdc.com/download/gpl> or obtained on CD for a nominal charge from <http://support.wdc.com/download/gpl> or by calling Customer Support within three years of the date of purchase; 2) you may re-use, re-distribute, and modify the GPL Software; 3) with respect solely to the GPL Software, no warranty is provided, to the extent permitted by applicable law; and 4) a copy of the GPL is included herewith, may be obtained at <http://www.gnu.org>, and may also be found at <http://support.wdc.com/download/gpl>. Modification of or tampering with the Software, including but not limited to any Open Source Software, is solely at your own risk. Western Digital is not responsible for any such modification or tampering. Western Digital will not support any product in which you have or have attempted to modify the Software supplied by Western Digital.

# Index

## A

Accessories, optional 3

## B

Box contents 2

## C

### CAUTION

- about disconnecting the system 20
- about erasing the drives 16

China RoHS compliance 29

Compliance, regulatory 28

Configurations, RAID 1

Connecting the device 6

## D

### Device

- compatibility 3
- connecting 6
- disk formats 3
- drive diagnostics and status checks 11
- drive erase function 16
- features 1
- handling precautions 5
- hardware 2
- registration 10

Diagnostics dialog 11

Disconnecting the system 20

Disk drive formats 3

Disk image, downloading and restoring 19

Drive replacement procedure 21

### Drive Utilities

- device registration function 10, 18
- diagnostics function 10
- drive erase function 10, 16
- RAID management function 10, 12

## E

Ejecting the drives 20

Environmental compliance, China 29

Erasing the drives 16

- CAUTION about erasing the drives 16

## F

FCC information, class B 28

Full media scan 11

## G

GNU General Public License 32

## H

Handling precautions 5

## K

KC notice (Republic of Korea) 29

Kensington security slot 5

Kit contents 2

## L

Limited warranty information 30

## O

Obtaining service 29, 31

Online support, accessing ii

Operating system compatibility 3

Optional accessories 3

## P

Physical description 4

Power adapter, changing 6

Power/activity LED 4

Precautions for handling the system 5

Product features 1

## Q

Quick drive test 11

## R

### RAID Management

Configuration dialog 13

Status display 12

### RAID modes 1

configuration, changing 13

status, checking 12

Registering the device 18

Registration dialog 19

Regulatory compliance 28

Replacing a drive 21

Restoring the software disk image 19

RoHS compliance 29

## S

S.M.A.R.T. status check 10

Safely dismounting drives 20

Safety compliance 28

Service and support, WD ii

## T

Technical support, contacting ii

Thunderbolt cables 2

Thunderbolt ports 4

Time Machine, using with 7, 15

## W

Warranty information 29, 30, 31

WD service ii, 29, 31

WD technical support, contacting ii

---

Information furnished by WD is believed to be accurate and reliable; however, no responsibility is assumed by WD for its use nor for any infringement of patents or other rights of third parties which may result from its use. No license is granted by implication or otherwise under any patent or patent rights of WD. WD reserves the right to change specifications at any time without notice.

Western Digital, WD, the WD logo, WD VelociRaptor, and My Book are registered trademarks in the U.S. and other countries, and My Book VelociRaptor and Data Lifeguard are trademarks of Western Digital Technologies, Inc. Thunderbolt and the Thunderbolt logo are trademarks of Intel Corporation in the U.S. and/or other countries. Apple, Mac, OS X, and Time Machine are trademarks of Apple, Inc., registered in the U.S. and other countries. Other marks may be mentioned herein that belong to other companies.

© 2012 Western Digital Technologies, Inc. All rights reserved.

Western Digital  
3355 Michelson Drive, Suite 100  
Irvine, California 92612 U.S.A.

4779-705078-A00 Jul 2012

## Free Manuals Download Website

<http://myh66.com>

<http://usermanuals.us>

<http://www.somanuals.com>

<http://www.4manuals.cc>

<http://www.manual-lib.com>

<http://www.404manual.com>

<http://www.luxmanual.com>

<http://aubethermostatmanual.com>

Golf course search by state

<http://golfingnear.com>

Email search by domain

<http://emailbydomain.com>

Auto manuals search

<http://auto.somanuals.com>

TV manuals search

<http://tv.somanuals.com>