

**INSTRUCTIONS FOR INSTALLATION OF
NEW ANTI-SHOCK-OUT DEVICE
PART 310C522G01
ON
WESTINGHOUSE DBN 640 FRAME
TYPE ACB CIRCUIT BREAKERS**

CONTRACT: NObs 90386

**WESTINGHOUSE ELECTRIC CORPORATION
EAST PITTSBURGH, PENNSYLVANIA**

I.B. 44Y2026-640

BUREAU OF SHIPS

• NAVY DEPARTMENT •

SEPTEMBER, 1964

INDEX

Paragraph	Subject	Page
-	Index	2
-	List of Figures	2
1	List of Tools Required.	3
2	List of Parts Supplied.	3
3	Preliminary Instructions.	3
4	Removal of Old Parts.	4
5	Installation of New Parts	4
5.3	Adjusting of New Parts.	5
6	Temporary Displacement of Shunt Trip.	5
7	Temporary Displacement of Undervoltage Trip	5
8	Modification of Electric Lockout Mounting	6
9	Modification of Hold-in Device.	6
10	Position of Undervoltage Trip and Electric Lockout when Checking Anti-Shock-Out Device	6

LIST OF FIGURES

Figure	Title	Page
1	Identification of Main Components	4
2	Identification of Details and Hardware Locations.	5
3	Breaker with New Anti-Shock-Out Device.	6
4	New Anti-Shock-Out Device	6

INSTRUCTIONS FOR INSTALLATION OF NEW ANTI-SHOCK-OUT DEVICE PART #310C522G01 ON
WESTINGHOUSE DBN 640 AMPERE FRAME TYPE ACB CIRCUIT BREAKER

- | | | | |
|-------|---|-------|--|
| 1 | Tools Which Ship's Crew Must Provide | 2.3 | Tools |
| 1.1 | Miscellaneous socket wrenches and screw drivers | 2.3.1 | *CSK tool. Required only if breaker has an electric lockout.
*Wood block (12)
*One per ship with instructions |
| 1.2 | One screw driver which will pass through 5/16 inch diameter hole (to remove screw (1) Fig. 2) | | |
| 1.3 | A small hand grinder will be required on surface ships only for modifying hold-in lever as described in paragraph (9.1) | 3 | Preliminary Instructions - study this leaflet before proceeding with work. |
| 1.4 | A hand drill for countersink tool required in paragraph 8.2 (CSK has 3/8 diameter shank) | 3.1 | Be sure all material and tools are readily available. See paragraphs (1) and (2). |
| 2 | List of Parts Supplied in One Package for One Breaker | 3.2 | WARNING - observe the following safety rules. |
| 2.1 | Anti-shock-out device (Figure 4) | 3.2.1 | Lock remote controls so that breaker can not be remotely operated. |
| 2.2 | New mounting hardware as below: | 3.2.2 | De-energize all control busses and tag circuits so no-one energizes them. |
| 2.2.1 | Screw (11) 1/4-20 x 1/2 pansems screw (captive in box-discard nut but be careful to keep screw in place.) | 3.2.3 | De-energize all main busses to breaker, lock them out or tag circuits so that no-one energizes them. |
| 2.2.2 | Screw (22) 1/4-20 x 3/4 fil. HD screw | 3.2.4 | Manually close and trip breaker and observe that even a de-energized breaker can sever a finger. For any work done with breaker closed, insert wood block (12) in mechanism as shown in Figure (3). For removing devices, it is often safest and most convenient to block breaker part way closed. |
| 2.2.3 | Screw (33) 5/16-18 x 3/4 fil. HD screw | | |
| 2.2.4 | Screw (77) 5/16-18 x 5/8 flat HD screw. Required only if breaker has an electric lockout. | | |

- 4 Removal of Old Parts - remove operating handle, faceplate or enclosure cover, and right pole arc chute.
- 4.1 Replace operating handle.
- 4.2 If breaker has shunt trip or undervoltage as shown in Figure (1), see paragraph (6) or (7) for their temporary displacement.
- 4.3 Remove old anti-shock device by removing its cover and screws (1) and (2) (Figure 2).
- 4.4 Remove one mechanism bolt (3) (Figure 2), and discard.
- 4.5 If breaker has an electric lockout device and/or a hold-in device, modify as per paragraph (8) and/or (9).
- 5 Installation of New Parts - remove cover from new anti-shock-out device (Fig. 3).
- 5.1 Slide anti-shock-out device into position shown in Figure (3).
- 5.1.1 Be sure screw (9) (Figure 3) is not caught under trip bar.
- 5.1.2 Be sure that two little out board rollers (Fig. 4) on new anti-shock-out device are either in front of (or below) trip lever as they are inserted through hole (A) in breaker frame (Figure 2).
- 5.1.3 Start but do not tighten new screw (11). (Fig. 2)
- 5.1.4 Start newscrew (22) but do not tighten. (Fig. 2). Do not damage gears.
- 5.1.5 Start new screw (33). (Fig. 2)
- 5.1.6 Tighten newscrews (11), (22) and (33) in place. (Fig. 2). Be sure screws are compressing lockwashers and are not just tight on burrs.

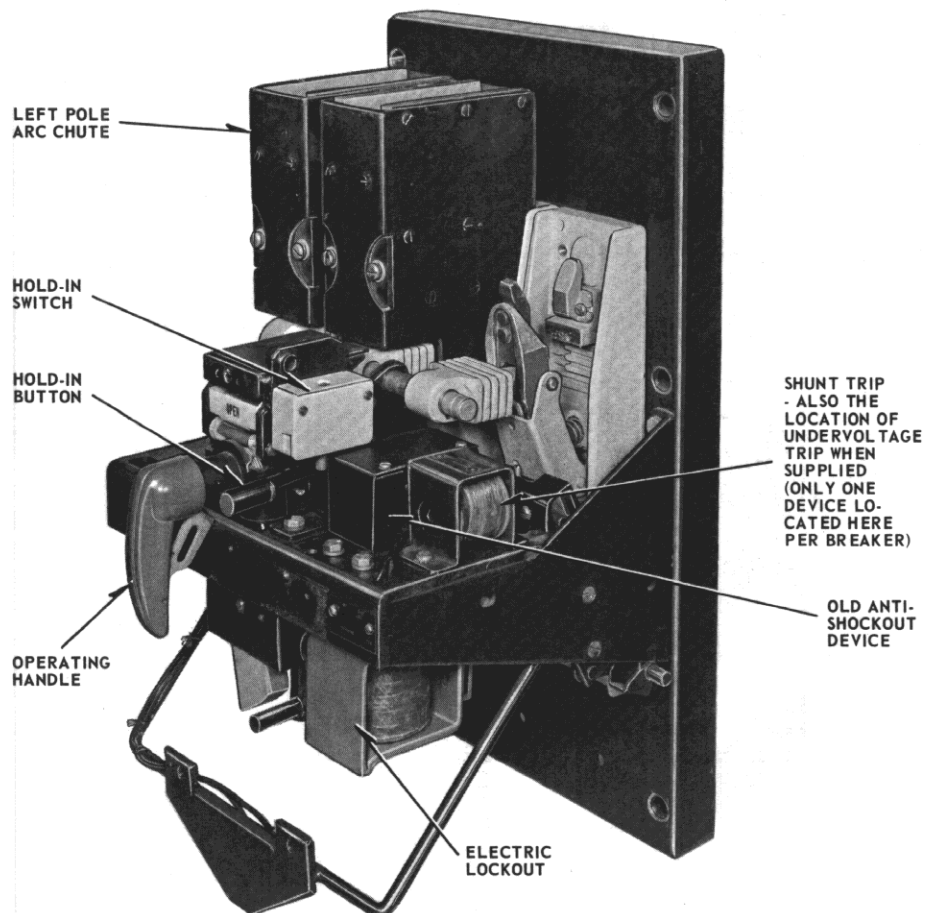

FIGURE 1. Identification of Main Components

8 Modification of Electric Lockout Mounting - replace screw (2) to hold electric lockout while performing work in paragraph (8.1) and (8.2).

8.1 Remove and discard bolt (7), but do not disturb bolt (8).

8.2 CSK hole (CSK tool provided) for new flat head screw (77) and install screw and tighten in place.

8.3 Remove screw (2) and discard.

9 Modification of Hold-in Device - if breaker has a hold-in device it must be partially removed per paragraph (9.1). If it also has a shunt trip then hold-in switch must be removed per paragraph 9.2.

9.1 With small hand grinder cut lever as

shown in Figure 2. When ground 2/3 through, it may be broken off. Remove hold-in device button and bracket to which it is fastened and discard. This can be best done with breaker closed by lifting and twisting until bracket and button unhook from pin in hold-in lever Figure 2.

9.2 Remove hold-in switch (Fig. 1) and discard. Splice the two leads which were in switch together.

10 When checking Anti-Shock-Out Device, tie arm of undervoltage trip to prevent its touching trip bar and hold up core of electric lockout to prevent its touching trip bar.

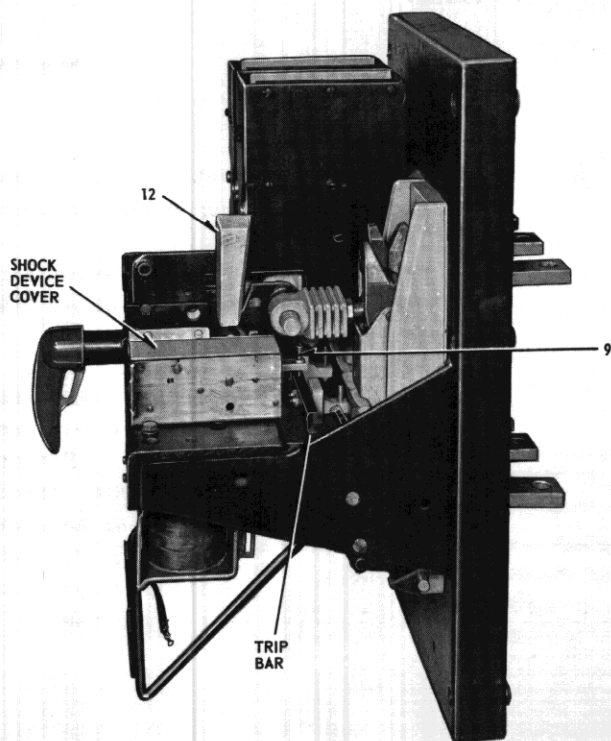

FIGURE 3. Breaker with New Anti-Shockout Device

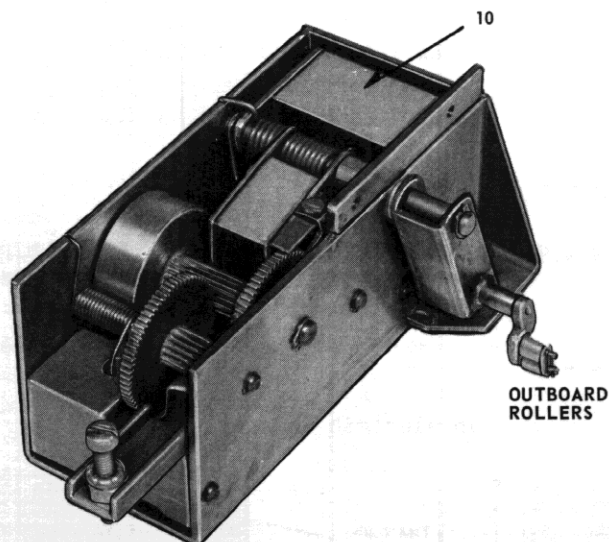

FIGURE 4. New Anti-Shockout Device

Free Manuals Download Website

<http://myh66.com>

<http://usermanuals.us>

<http://www.somanuals.com>

<http://www.4manuals.cc>

<http://www.manual-lib.com>

<http://www.404manual.com>

<http://www.luxmanual.com>

<http://aubethermostatmanual.com>

Golf course search by state

<http://golfingnear.com>

Email search by domain

<http://emailbydomain.com>

Auto manuals search

<http://auto.somanuals.com>

TV manuals search

<http://tv.somanuals.com>