

10 CUP COOL TOUCH RICE COOKER



MODEL WST3008ZE

OWNER'S MANUAL



Westinghouse

IMPORTANT SAFEGUARDS

When using electrical appliances, basic safety precautions should always be followed including the following:

1. Read all instructions.
2. Do not touch hot surfaces. Use handles or knobs.
3. To protect against electrical shock do not immerse cord, plugs, or appliance in water or other liquid.
4. Close supervision is necessary when any appliance is used by or near children.
5. Unplug from outlet when not in use and before cleaning. Allow to cool before putting on or taking off parts.
6. Do not operate any appliance with a damaged cord or plug or after the appliance malfunctions or has been damaged in any manner. Contact Consumer Service for examination, repair or adjustment.
7. The use of accessory attachments not recommended by the appliance manufacturer may cause injuries.
8. Do not use outdoors.
9. Do not let cord hang over edge of table or counter, or touch hot surfaces.
10. Do not place on or near a hot gas or electric burner, or in a heated oven.
11. Extreme caution must be used when moving an appliance containing hot oil or other hot liquids.
12. To disconnect raise Selector Lever to WARM, then remove plug from wall outlet.
13. Do not use appliance for other than intended use.

SAVE THESE INSTRUCTIONS

For Household Use Only

ADDITIONAL IMPORTANT SAFEGUARDS

CAUTION HOT SURFACES: This appliance generates heat and escaping steam during use. Proper precautions must be taken to prevent the risk of burns, fires, or other injury to persons or damage to property.

1. A person who has not read and understood all operating and safety instructions is not qualified to operate this appliance. All users of this appliance must read and understand this Owner's Manual before operating or cleaning this appliance.
- 2. Unplug from outlet when not in use and before cleaning. To avoid electric shock, never immerse or rinse this appliance in water or any other liquid.**
3. If this appliance falls or accidentally becomes immersed in water, unplug it from the wall outlet immediately. **Do not reach into the water!**
4. When using this appliance, provide adequate air space above and on all sides for air circulation. Do not operate this appliance while it is touching or near curtains, wall coverings, clothing, dishtowels or other flammable materials.
5. To reduce the risk of fire, do not leave this appliance unattended during use.
6. If this appliance begins to malfunction during use, immediately unplug the cord. Do not use or attempt to repair a malfunctioning appliance!
7. The cord to this appliance should only be plugged into a 120V AC electrical wall outlet.
8. Do not use this appliance in an unstable position.
9. Do not use the Cooking Pot or Glass Lid if cracked or damaged.
10. Do not use the WARM Mode to reheat cold rice or other foods.
11. Avoid electric shock by unplugging the Rice Cooker before washing or adding water.
12. Never plug in the Rice Cooker without the Cooking Pot inside the Main Housing.
13. To avoid burns, stay clear of the Steam Hole during cooking. Also, wait for the Rice Cooker to cool down completely before touching or cleaning the Main Housing and Glass Lid.
14. Never use the Cooking Pot on a gas or electric cooktop or on an open flame.
15. Do not leave the plastic Rice Paddle or Rice Measuring Cup in the Cooking Pot while on and in use.
16. Lift off lid carefully to avoid scalding, and allow water to drip into Rice Cooker.
17. To reduce the risk of electric shock, cook only in the removable container (Cooking Pot). Do not pour liquid directly into the Main Housing. Never put liquid into the Main Housing, only into the Cooking Pot.

POLARIZED PLUG

This appliance has a polarized plug (one blade is wider than the other). To reduce the risk of electric shock, this plug is intended to fit into a polarized outlet only one way. If the plug does not fit fully in the outlet, reverse the plug. If it still does not fit, contact a qualified electrician. Do not attempt to modify the plug in any way.

SHORT CORD INSTRUCTIONS

A short power-supply cord is provided to reduce the risk resulting from becoming entangled in or tripping over a longer cord.

The use of an extension cord is not recommended.

ELECTRIC POWER

If the electrical circuit is overloaded with other appliances, your appliance may not operate properly. It should be operated on a separate electrical circuit from other appliances.

GETTING TO KNOW YOUR WESTINGHOUSE WST3008ZE 10 CUP COOL TOUCH RICE COOKER

PRODUCT MAY VARY SLIGHTLY FROM ILLUSTRATION

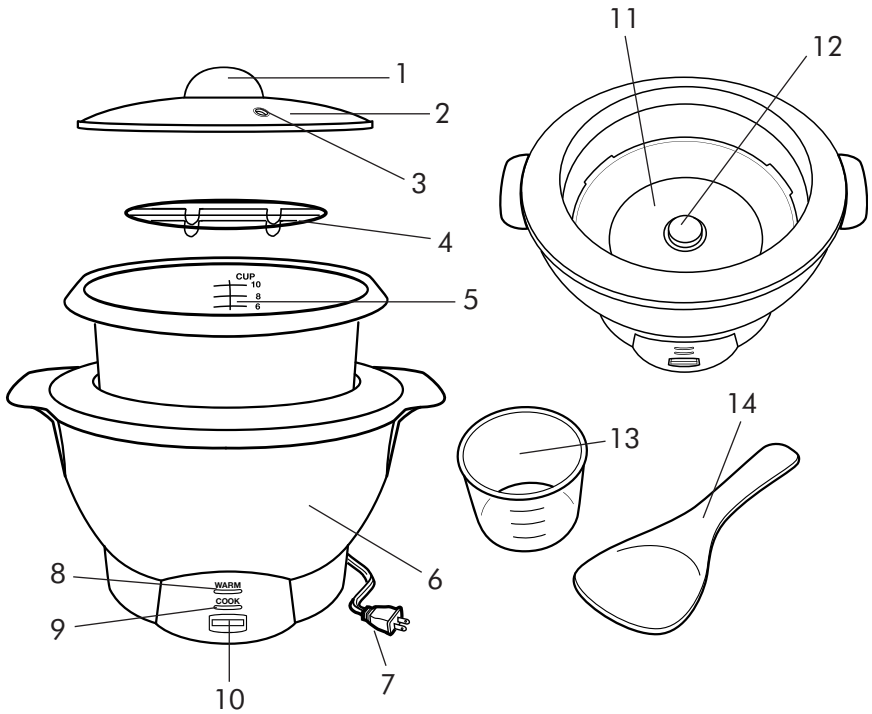

1. Lid Handle
(P/N 21762)
2. Glass Lid Assembly
(P/N 21763)
3. Steam Hole
4. Wire Cooking Rack
(P/N 21764TM)
5. Non-Stick Cooking Pot
(P/N 21765TM)
6. Cool-Touch Main Housing
7. Power Cord with Polarized Plug
8. WARM Light
9. COOK Light
10. Rice Cooking Selector Lever
11. Heating Plate
12. Thermostat
13. Rice Measuring Cup
(P/N 21774TM)
14. Rice Paddle
(P/N 21775TM)

BEFORE USING FOR THE FIRST TIME

1. Read all instructions.
2. Wash Cooking Pot, Glass Lid, Wire Cooking Rack, Rice Measuring Cup and Rice Paddle in warm, soapy water. Rinse and dry well.
3. Never immerse Main Housing in water.
4. Never place liquid in the Main Housing. Place it only in the Cooking Pot.
5. Never try to force the Rice Cooking Selector Lever to stay in the COOK Mode after it has moved up to the WARM Mode.
6. Never plug in the Cooker without first placing the Cooking Pot inside the Main Housing.
7. Always be sure Cooking Pot contains liquid when you plug in the Cooker.
8. Remember that the Rice Measuring Cup is not a standard measuring cup. When filled, it measures approximately $\frac{3}{4}$ cup.
9. Never wash any removable parts of the Cooker in the dishwasher.
10. Save these instructions and refer to them often.
11. If the outside of the Cooking Pot is wet when placed into the Cooker, this may cause a cracking noise while the unit heats up. Also, this may cause damage to the inner working of the appliance, so always wipe the outside of the Cooking Pot completely dry before use.

OPERATING INSTRUCTIONS

COOKING RICE

Many varieties of rice can be used, including basmati, wild, black rice, arborio, risotto, saffron rice, brown, and long grain. Do not use this Rice Cooker to cook instant rice.

A 180 ml ($\frac{3}{4}$ cup) Rice Measuring Cup is included with your Rice Cooker.

1. Make sure the Rice Cooker is unplugged. Take the Cooking Pot out of the Rice Cooker.
2. Using the Rice Measuring Cup provided, measure the amount of raw rice that you would like to cook.

NOTE: Make sure that the rice is leveled when the Rice Measuring Cup is filled.

3. **For Best Results...Rinse Your Rice Before Cooking.**

Pour desired amount of rice into a separate container. Wash and rinse the rice until the rinse water is clear. For information regarding rinsing rice, please refer to Cooking Rice General Information Section.

4. Place rinsed rice into the Cooking Pot.
5. When using your Rice Cooker, you may use either of 2 methods to measure the **amount of water** to use:
 - The Rice Measuring Cup provided

OR

- The Markings on the inside of the Cooking Pot.
6. When cooking long grain white rice, using the **Rice Measuring Cup**, add an equal amount of water to the Cooking Pot.

RAW RICE

2 Rice Measuring Cups
4 Rice Measuring Cups
6 Rice Measuring Cups
8 Rice Measuring Cups
10 Rice Measuring Cups

WATER TO BE ADDED

2 Rice Measuring Cups
4 Rice Measuring Cups
6 Rice Measuring Cups
8 Rice Measuring Cups
10 Rice Measuring Cups

OPERATING INSTRUCTIONS (Cont.)

COOKING RICE (Cont.)

7. Or, you may measure the water using the **markings on the inside of the Cooking Pot.**



Add rice to Cooking Pot first, then add water to the corresponding level.

Example: To prepare 6 cups of raw rice, rinse rice and add to the Cooking Pot; add water up to LEVEL INDICATOR 6.

(As you gain experience, adjust water to personal taste.)

8. Replace the Cooking Pot back into the 10 Cup Cool Touch Rice Cooker's Main Housing.

Rotate it slightly to make sure that it is well seated on the Heating Plate/Thermostat Assembly.

NOTE: Always wipe the outside of the Cooking Pot completely dry before use. If the outside of the Cooking Pot is wet when placed into the Cooker, this may cause a cracking noise while the unit heats up. Also, this may cause damage to the inner workings of the appliance.

9. Replace the Glass Lid.

CAUTION: Do not operate the 10 Cup Cool Touch Rice Cooker without replacing the Lid. Burns or other serious injury may occur.

10. Plug the 10 Cup Cool Touch Rice Cooker into a 120V AC electrical outlet.

Press the Rice Cooking Selector Lever down, the COOK Light will illuminate and the cooking process will begin.

11. When the 10 Cup Cool Touch Rice Cooker is done cooking, the Selector Lever will rise and the Rice Cooker will automatically go into the WARM Mode.

For best results, let the cooked rice sit for 15 minutes before stirring or removing. This allows the steam to finish the cooking process.

OPERATING INSTRUCTIONS (Cont.)

COOKING RICE (Cont.)

12. Mix the rice.

After rice has steamed for 15 minutes, carefully open the Lid as steam will escape. Use the Rice Paddle provided or any other non-metal long-handle utensil to scoop and mix the rice well.

Allow all steam to escape.

13. Keep Warm.

When the cooking is completed, the Selector Lever will rise and the 10 Cup Cool Touch Rice Cooker will automatically go into the **WARM** Mode.

If the **WARM** Mode is not desired, simply unplug the 10 Cup Cool Touch Rice Cooker from the wall. Do not touch the Main Housing or Cooking Pot until they have cooled completely.

14. Allow the 10 Cup Cool Touch Rice Cooker to cool completely before cleaning.

15. When the 10 Cup Cool Touch Rice Cooker is not being used, please keep it unplugged.

GENERAL INFORMATION

Rice is grown on marshy land that floods easily. It does not need to be milled or ground; only the outer husks must be removed, leaving behind what is known as brown or whole rice, the most nutritious of rices.

Information has recently been published about more healthful ways to eat, by consuming less fat, less protein and more complex carbohydrates in our diets. Because brown rice is about 8% protein, 87% carbohydrates and almost no fat, it is a perfect ingredient in a healthful diet.

Because rice is a valuable source of carbohydrates, it is starchy by nature. To obtain fluffier, less starchy rice, you can rinse the rice before cooking. But by rinsing or soaking the rice, you lose some of the vitamins, which are water soluble. Please refer to your rice package directions for specific instructions.

TYPES OF RICE

Brown Rice - Contains more vitamin B complex, iron and calcium and takes longer to cook than white rice. Its flavor is nutty and its texture is chewy. (See Cooking Chart.)

OPERATING INSTRUCTIONS (Cont.)

TYPES OF RICE (Cont.)

White Rice - Includes several kinds of white rice, most of which can be prepared in your 10 Cup Cool Touch Rice Cooker.

Long-Grain Rice - Less starchy than short-grain rice, so it separates into individual grains more than short-grain rice.

Short-Grain Rice - More moist and tender than long-grain rice. It has a softer texture and starchier flavor.

White rice will take about 20-25 minutes to cook, (brown rice approximately 50 minutes). When rice is done, the Selector Lever will rise and the 10 Cup Cool Touch Rice Cooker will automatically go into the **WARM** Mode. Allow rice to stand on **WARM** for 10 to 15 minutes to ensure fluffy rice. You can keep cooked rice on the **WARM** setting for several hours without the taste of the rice being affected. Do not remove Cover until ready to serve. **The Cooking Pot remains very hot after cooking or keeping warm. Use a pot holder when handling.**

WHY RICE?

Grains (including rice) are finally getting the attention they deserve as they move into the nutritional spotlight. The new USDA dietary recommendations highlight grains as an essential part of a healthy, whole foods diet. With their impressive fiber, complex carbohydrates and protein profiles, they are, without a doubt, some of Mother Nature's most perfect foods.

Grains are the edible portion of cereal plants. The grain or kernel is technically a complete fruit and houses most of its nutritional value. In addition to their high fiber content, grains are an excellent source of B vitamins and many minerals, including magnesium, iron, zinc, potassium and selenium. The germ oils found in the germ layers of whole grains contain vitamin E, an important antioxidant.

GRAIN GLOSSARY

Rice is a staple food in many countries. Although long-grain rice is consumed more than any other rice around the world, it is inferior to brown rice in both taste and nutrition. Brown rice is not only more complete nutritionally, it has a wonderful nutty aroma and flavor.

OPERATING INSTRUCTIONS (Cont.)

GRAIN GLOSSARY (Cont.)

Polished rice (white) has been bleached, cleaned, pearled (polished with talc), then often oiled and coated. This refining process causes the loss of its hull, bran and germ, which are removed from the grain (along with most of its nutrients) leaving only the starchy endosperm. As white rice is rather bland when eaten by itself, it is usually served under steamed or sauteed vegetables and topped with a flavorful sauce, such as curry or peanut.

Long grain brown rice contains fiber and the nutrient-rich bran and germ, as well as the starchy endosperm. In addition to being more flavorful, brown rice digests more slowly, which provides energy over a longer period of time. Brown rice is a satisfying meal companion and can even serve as the main focus for a meal. While not as high in protein as wheat and some other grains (10%), the high quality protein in brown rice is easily utilized by the body. Brown rice is also a good source of the B vitamins and several minerals, including magnesium, potassium, zinc, iron, and selenium.

LONG GRAIN BROWN RICE COOKING CHART

The 10 Cup Cool Touch Rice Cooker automatically switches from **COOK** Mode to **WARM** Mode when all the liquid evaporates from the Cooking Pot. However, for fluffy rice, allow rice to stand for approximately 10 minutes, covered, on **WARM** before serving.

NOTE: Always place rice in Cooking Pot before adding water.

AMOUNT OF RAW RICE	WATER LEVEL INDICATOR
2 Rice Measuring Cups	to 4-cup line
3 Rice Measuring Cups	to 5-cup line
4 Rice Measuring Cups	to 6-cup line
5 Rice Measuring Cups	to 7-cup line
6 Rice Measuring Cups	to 8-cup line
7 Rice Measuring Cups	to 9-cup line
8 Rice Measuring Cups	to 10-cup line

OPERATING INSTRUCTIONS (Cont.)

USING THE WIRE COOKING RACK TO STEAM FOODS

1. Using a liquid measuring cup, add 2½ cups (20 ounces) of water to the Cooking Pot.
2. Place the Wire Cooking Rack on the bottom of the Cooking Pot.
3. Larger vegetables can be placed directly on the Wire Cooking Rack. A heat-resistant steaming basket may be used to cook smaller vegetables. Place steaming basket in the bottom of the Cooking Pot and add smaller vegetables. Replace Glass Lid.
4. Replace Cooking Pot back into the 10 Cup Cool Touch Rice Cooker's Main Housing. Rotate it slightly to make sure that it is well seated on the Heating Plate/Thermostat Assembly.
5. Plug into a 120V AC electrical outlet. Press the Rice Cooking Selector Lever down to the COOK mode. The COOK Light will illuminate. The cooking process begins as soon as the Light illuminates.
6. The times in the cooking chart are approximate. Set a timer and check for doneness at the suggested cooking time; continue cooking if necessary. The size and shape as well as personal taste may call for adjustments. If you want softer vegetables, add more water if necessary, and steam for additional time. Do not allow the water in the Cooking Pot to boil dry.
7. At the end of the cooking time, raise the Selector Lever to WARM and unplug the 10 Cup Cool Touch Rice Cooker from the wall.
NOTE: Using the WARM mode for vegetables is not recommended.
8. Use the Rice Paddle provided or any other non-metallic long-handle utensil to remove the vegetables from the Rice Cooker. Allow the 10 Cup Cool Touch Rice Cooker to cool completely before cleaning.

OPERATING INSTRUCTIONS (Cont.)

FRESH VEGETABLE STEAMING CHART

Vegetable	Amount	Suggested Cooking Time
Artichoke, Whole	2 large or 4 small	44 - 46 min.
Asparagus	1 ½ lb. (36 spears)	24 - 27 min.
Baby Carrots	2 lb.	35 - 39 min.
Broccoli	1 lb. (2" florets, 1" stems)	28 - 30 min.
Brussels Sprouts	12 oz.	25 - 28 min.
Cabbage	1 large head, chunked	45 - 47 min.
Cauliflower	1 lb. (3" florets)	22 - 26 min.
Corn-On-The-Cob	5 medium ears, halved	40 - 45 min.
Green Beans, Whole	1 ½ lb. (tips removed)	30 - 40 min.
Potatoes: All-Purpose	5 average size, quartered	30 - 40 min.
New	8 average size, halved	25 - 30 min.
Sweet Potato	4 medium, 1-inch slices	30 - 35 min.
Spinach	1 ½ lb.	18 - 22 min.

FROZEN VEGETABLE STEAMING CHART

Vegetable	Amount	Suggested Cooking Time
Broccoli (Spears)	2 bags (16 oz. each)	36 - 38 min.
Brussels Sprouts	2 bags (16 oz. each)	25 - 29 min.
Cauliflower	2 bags (16 oz. each)	26 - 30 min.

USER MAINTENANCE INSTRUCTIONS

This appliance contains no user serviceable parts. Do not try to repair it yourself. Any servicing requiring disassembly other than cleaning must be performed by a qualified appliance repair technician.

Always remember to unplug the unit from the wall outlet when not in use and before cleaning.

1. Be careful not to dent the Cooking Pot, especially the bottom of it. To work properly and produce the best cooking results, the Cooking Pot must fit snugly on top of the thermostat.
2. DO NOT let loose grains of rice or other food particles fall into the bottom of the Main Housing because they might prevent the Heating Plate/Thermostat Assembly from fitting tightly against the bottom of the Cooking Pot and cause inadequate cooking.
3. Use the plastic Rice Paddle or a wooden spoon to stir and remove food from the Cooking Pot. NEVER use any metal utensils.
4. Never use abrasive cleansers or scouring pads because they can damage the finish of both the Cooking Pot and Main Housing.

CARE AND CLEANING

1. **PLEASE NOTE:** It is normal to have a brown 'rice crust' coating the bottom layer of the Cooking Pot when the rice has finished cooking and steaming.
2. This appliance should be cleaned after every use. Unplug the unit from the wall outlet. NEVER immerse Main Housing or Power Cord in water. Allow the unit to cool before cleaning.
3. Let the Rice Cooker cool. Fill Cooking Pot with warm water and allow to sit for a while. Wash in warm, soapy water with a sponge and dry thoroughly with a cloth.
4. The Glass Lid, Wire Cooking Rack, Rice Measuring Cup and Rice Paddle may also be washed in warm, soapy water.

CAUTION: Handle the Glass Lid with extreme care, as it may become slippery when wet.

5. Never wash any removable parts of the Rice Cooker in the dishwasher.
6. The Main Housing can be wiped clean with a soft, slightly damp cloth or sponge.
7. **NEVER POUR LIQUID INTO THE MAIN HOUSING OR IMMERSE IT IN WATER.**

USER MAINTENANCE INSTRUCTIONS

(Cont.)

STORAGE

1. Unplug the unit from the wall outlet and clean all parts. Be sure all parts are dry before storing. Store appliance in its box or in a clean, dry place. Never store it while it is hot, wet or still plugged in. Never wrap Power Cord around the appliance.
2. To avoid damage to the Cooking Pot or Glass Lid, wrap a soft cloth around the Lid and store it upside down over the Cooking Pot.

TROUBLE SHOOTING

Symptom	Possible Solutions
No Indicator Lights are Illuminated.	Make sure the 10 Cup Cool Touch Rice Cooker is plugged in.
Water overflows during cooking.	Before cooking, make sure you don't fill above top water level. Make sure Lid is closed before cooking.
Cooked rice is too dry or not completely cooked.	Before cooking, make sure you add enough water to the Cooking Pot for the total amount of raw rice added. After cooking, add $\frac{1}{4}$ cup water and raise Selector Lever to WARM Mode for 10 minutes. Stir. Check between the Cooking Pot and Heating Plate/Thermostat Assembly for any foreign substances. Be sure the area is clean.
Cooked rice is too watery.	Before cooking, make sure you don't add too much water to the Cooking Pot for the total amount of raw rice added. Check between the Cooking Pot and Heating Plate/Thermostat Assembly for any foreign substances. Be sure the area is clean. Make sure the cooking cycle is not interrupted. If the Power Cord is unplugged, the unit will not operate and the rice will not cook.

TROUBLE SHOOTING (Cont.)

Symptom	Possible Solutions
Rice is scorched.	<p>Check between the Cooking Pot and Heating Plate/Thermostat Assembly for any foreign substances. Be sure the area is clean.</p> <p>Be sure to wash the Cooking Pot after each use.</p> <p>Be careful not to add easily-scorched ingredients such as sugar, to the recipe before cooking.</p>
Steam escapes between Glass Lid and Cooking Pot during cooking.	<p>Check between the Glass Lid and Cooking Pot for foreign substances, including rice kernels that may prevent the Glass Lid from closing all the way. Be sure the area is clean.</p>
Warmed rice smells bad or discolored.	<p>For best results, don't use the WARM option with brown rice. The bran in unrefined grains can "break down" when kept at low heat for extended periods of time, causing an unpleasant smell and taste.</p> <p>Make sure the Glass Lid is properly centered in position over Cooking Pot when using the WARM Mode.</p> <p>Be sure to wash the Cooking Pot after each use.</p> <p>Make sure you don't leave the Rice Paddle or other plastics in the 10 Cup Cool Touch Rice Cooker while it is cooking or warming.</p>

If none of these Trouble Shooting solutions are successful, contact our Consumer Service Dept. at 800-233-9054 for further advice.

LIMITED ONE YEAR PRODUCT WARRANTY

Warranty: This product is warranted to be free from defects in materials and workmanship for a period of one (1) year from the original purchase date. This product warranty covers only the original consumer purchaser of the product.

Warranty Coverage: This warranty is void if the product has been damaged by accident in shipment, unreasonable use, misuse, neglect, improper service, commercial use, repairs by unauthorized personnel, normal wear and tear, improper assembly, installation or maintenance abuse or other causes not arising out of defects in materials or workmanship. This warranty is effective only if the product is purchased and operated in the USA or Canada, and does not extend to any units which have been used in violation of written instructions furnished with the product or to units which have been altered or modified or to damage to products or parts thereof which have had the serial number removed, altered, defaced or rendered illegible.

Implied Warranties: ANY WARRANTIES IMPLIED WHICH THE PURCHASER MAY HAVE ARE LIMITED IN DURATION TO ONE (1) YEAR FROM THE DATE OF PURCHASE. Some states and provinces do not allow limitations on how long an implied warranty lasts, so the above limitation may not apply to you.

Warranty Performance: During the above one-year warranty period, a product with a defect will be either repaired or replaced with a comparable model when the product is returned to Zellers. The repaired or replacement product will be in warranty for the balance of the one-year warranty period and an additional one-month period. No charge will be made for such repair or replacement within the warranty period.

Important Notice: If any parts are missing or defective, return this product to the place of purchase.

Any questions or comments can be directed to the Consumer Relations Department. Please write to or call:

Consumer Relations Dept.
P.O. Box 6916
Columbia, MO 65205-6916
1(800) 233-9054

Limitation of Remedies: No representative or person is authorized to assume for us any other liability in connection with the sale of our products. There shall be no claims for defects or failure of performance or product failure under any theory of tort, contract or commercial law including, but not limited to negligence, gross negligence, strict liability, breach of warranty, and breach of contract. Repair, replacement or refund shall be the sole remedy of the purchaser under this warranty. Some states and provinces do not allow the exclusion or limitation of incidental or consequential damages, so the above limitation or exclusion may not apply to you.

Legal Rights: This warranty gives you specific legal rights, and you may also have other rights which vary from state to state/province.

WESTINGHOUSE™,  and "YOU CAN BE SURE...IF IT'S WESTINGHOUSE™" are trademarks of WESTINGHOUSE ELECTRIC CORPORATION and used under license by Salton, Inc. **In no event shall Salton be liable for any incidental or consequential damages, losses or expenses.**

Made in China

"© 2003
All Rights Reserved"

P/N 61313
Printed in China

Free Manuals Download Website

<http://myh66.com>

<http://usermanuals.us>

<http://www.somanuals.com>

<http://www.4manuals.cc>

<http://www.manual-lib.com>

<http://www.404manual.com>

<http://www.luxmanual.com>

<http://aubethermostatmanual.com>

Golf course search by state

<http://golfingnear.com>

Email search by domain

<http://emailbydomain.com>

Auto manuals search

<http://auto.somanuals.com>

TV manuals search

<http://tv.somanuals.com>