



NAVSHIPS 361-1465

TECHNICAL MANUAL

PRELIMINARY

PART 3 - CHAPTER 1

NAVY TYPE ACB
1600 FRAME SIZE

AIR CIRCUIT BREAKER (GENERATOR)

WESTINGHOUSE TYPE DBN-60S

DIRECT CURRENT BREAKER
3000A - Continuous Current
335 Volts, D-C - 2 Pole

Contract NObs 62391

PART OF BUFFALO S.O. 38-S-795

SWITCHGEAR I.B. 35-270-C14

WESTINGHOUSE ELECTRIC CORPORATION
East Pittsburgh Plant, East Pittsburgh, Pa.

BUREAU OF SHIPS - NAVY DEPARTMENT - WASHINGTON, D.C.

INDEX

Description	Page
List of Illustrations	ii
GENERAL DESCRIPTION	1
Identification Data	1
General	1
Construction	1
Operation	1
Mounting	2
Control Voltage	2
Maintenance	2
COMPONENTS AND ATTACHMENTS	4
Arc Chutes	4
Contact Assembly	4
Operating Mechanism	5
Position Indicator	6
Anti-Shock-Close Device	7
Closing Magnet of Solenoid	7
Closing Relay	8
Anti-Shock-Open Device	10
Series-Overcurrent-Trip Device	11
Auxiliary Switch	12
Shunt-Trip Device	13
Undervoltage Trip	13
Reverse Current Trip	14
Mechanical Interlock	16
Repair Parts	17

LIST OF ILLUSTRATIONS

Illustrations Included After Page 17

Fig.	Title	Page
1	Front View of Breaker (TP 55-482)	
2	Rear View of Breaker (TP 55-483)	
3	General Assembly (Dwg. 47-A-6551)	
4	Pole Unit (TP 55-485)	
5	Top View of Operating Mechanism (TP 55-486)	
6	Operating Mechanism Assembly (Dwg. 46-A-8538)	
7	Closing Magnet (TP 55-488)	
8	Closing Relay (TP 55-489)	
9	Anti-Shock-Open Device (TP 55-490)	
10	Overcurrent Tripping Curve (Curve 388514)	
11	Series Overcurrent Trip Device (TP 55-492)	
12	Auxiliary Switch (TP 55-493)	
13	Shunt Trip Device (TP 55-494)	
14	Undervoltage Trip (Dwg. 63-A-5344)	
15	Reverse Current Trip (Dwg. 47-A-6550)	
16	Mechanical Interlock (Dwg. 63-A-5346)	
17	Certification Data (Dwg. 32-B-8055)	
18	Certification Data (Dwg. 32-B-8056)	
19	Master Plan (Dwg. 1-JH-220)	

GENERAL DESCRIPTION

IDENTIFICATION DATA

The circuit breakers described in this book are the generator breakers for the SSR572 and SSR573. The identifying "Shop Order" (which appears on the breaker nameplate) and the applicable "Certification Data" is as follows:

Shop Order	Certification Data Drawing	
	Westinghouse	Buships
32-Y-4763	32-B-8055	SS572-S6205-1503469
32-Y-4764	32-B-8056	SS572-S6205-1503470
* 32-Y-9069	33-B-2596	
# 32-Y-9070	33-B-2597	

* This is spare breaker for 32-Y-4763.

This is spare breaker for 32-Y-4764.

GENERAL

The Type "DBN-60S" is a modified 1600 frame type ACB air circuit breaker as appears on master drawing 1-JH-220, Buships dwg. S6202-3,102,132 and as modified by applicable "Certification Data".

CONSTRUCTION

(Figs. 1 and 2)

A typical breaker as it would look in an enclosure is shown in figures 1 and 2. The breakers covered by this book are without enclosures.

The breaker foundation structure consists of a rigid steel chassis to which are bolted the several subassemblies that make up the complete circuit breaker. The subassemblies are the operating mechanism, pole units, arc chutes, closing relay, closing magnet, anti-shock-open device, anti-shock-close device, series-overcurrent trip devices, auxiliary switch, and shunt-trip device. These parts may be removed and replaced as complete assemblies.

OPERATION

The breaker may be operated manually or electrically. It is closed manually by depressing the latch in the operating handle on the front of the breaker and turning the handle 90 degrees in a clockwise direction. It may be tripped manually by turning the handle 45 degrees in the opposite direction with the latch held down. Electric operation is accomplished through use of the closing relay, the closing magnet, and the trip device. Turning the control switch on the control board to "CLOSE" operates the closing relay, which closes the circuit of the closing magnet (solenoid) until the control switch is released. The breaker is tripped by turning the same switch to "OPEN". This operation causes the shunt-trip device to trip the breaker. Excessive currents cause the series-overcurrent device to trip the breaker automatically.

MOUNTING (Fig. 3)

Fig. 3 shows the drilling plan to stud location. There are eight 1/2-inch mounting bolts which go through the switchboard and into tapped holes in the steel panel '150'.

CONTROL VOLTAGE

The closing magnet, the closing relay, and the shunt-trip device, operate on a nominal voltage of 250 volts d-c.

CAUTION - WARNING - THE CIRCUIT BREAKER SHOULD BE IN THE OPEN POSITION AND THE SWITCHBOARD DE-ENERGIZED BEFORE INSTALLING, ADJUSTING, INSPECTING, REPLACING PARTS, OR REMOVING THE CIRCUIT BREAKER. IF THE BUS CANNOT BE DE-ENERGIZED, USE INSULATED HANDLE TOOLS, RUBBER GLOVES, AND A RUBBER FLOOR MAT.

MAINTENANCE

a. Calibration

The overcurrent trip device is calibrated at the factory to trip the circuit breaker at currents greater than the short-time-delay pickup. The calibration point is marked on the scale plate. This calibration may be changed by turning the insulated knob on the overcurrent-trip device. Moving the indicator up decreases the pickup current, and moving it down increases the pickup current. Refer to Fig. 10 which shows the time vs. current characteristic of the overcurrent trip device.

b. Inspection

The frequency of inspection for maintenance will depend upon local conditions.

A complete inspection for preventive maintenance should be made at least once a year. It is recommended that a special inspection be given any breaker that has opened a heavy short-circuit current. If excessive heating is observed, look for loose or corroded contacts or connections. When inspecting the circuit breaker, examine the contact surfaces. Rough or high spots should be removed with a clean file or sandpaper. **DO NOT USE EMERY CLOTH.**

c. Lubrication

Bearing points in the mechanism may be oiled sparingly. Use a good grade of light machine oil and wipe off excess oil.

d. Disassembly (Fig. 3)

In order to make any inspections, repairs, or replacement of parts it will be necessary to open the switchboard door. To do this, proceed as follows:

1. Open the breaker.
2. Remove the handle '166' by removing the set screw. (See Fig. 6).

3. Open the switchboard door. Certain repairs and replacements can now be made without further disassembly. To inspect contacts, remove arc chutes '135', Fig. 3. To work on parts of the breaker still inaccessible, it will be necessary to remove the bracket-and-shelf assembly '151' and '152', as follows:
4. Remove ship's wiring from the terminal block '169'.
5. Remove the arc chutes '135'.
6. Remove the locking rings from each end of the crossbar '168'.
7. Disengage the insulating links by sliding the crossbar to one side, then to the other.
8. Remove the four hex-head bolts (using an extension socket wrench) that hold the shelf brackets '151' to the panel '150'. This frees the bracket-and-shelf assembly, '151' and '152' from the steel panel '150'. The whole assembly should be lifted slightly and pulled forward.
9. The breaker is now disassembled sufficiently for most replacements or repairs. The over-current-trip units may be removed by removing four hex-head bolts at the lower stud on the back of the breaker. Two of the bolts are above and two are below the lower stud.

e. Assembly

The breaker is reassembled in the reverse order.

CAUTION

Trip-finger screws '242' must be above the tops of the overcurrent trips '400' when the bracket-and-shelf assembly is put into the housing, or the trip finger will be broken. (See Figs. 3 and 6).

COMPONENTS AND ATTACHMENTS

a. ARC CHUTES
(Fig. 4)**1. Function**

Each pole unit has one arc chute '135'. The chute, mounted so that it surrounds and extends over the contact assembly of the pole, stretches and cools the arc drawn by the separating contacts. When the arc is drawn, it moves up into the chute by magnetic and thermal action, where it is quickly de-ionized and extinguished, thus opening the circuit in the least possible time. The arc chutes are an extremely important part of the circuit breaker. The breaker should never be energized without the arc chutes being mounted in place.

2. Description

Each arc chute consists of a number of asbestos plates supported in a laminated case and held in place on the molded base '100', by a clamping plate '136', and insulating spacers '146

b. CONTACT ASSEMBLY
(Fig. 4)**1. Function**

The contact assembly closes and opens the electrical circuit through the circuit breaker. The upper stud '120', the stationary contact '121', the series-overcurrent-trip device '400', and the lower stud '105', are stationary and are mounted on the molded base '100'. The moving contact assembly is hinged on the molded base by a pin '127', and is moved in and out by a molded insulating link '116', which is pivoted on the crossbar '168', Fig. 3. The moving contact assembly is closed, and held in the closed position against the force of the accelerating springs '131', by a molded insulating link '116'. When the breaker is tripped, and the force exerted by the molded insulating link is released, the accelerating springs '131', quickly force the moving contact assembly to the open position. When the breaker interrupts high, short-circuit currents, magnetic forces play a large part in the rapid opening of the contacts. The moving contact assembly moves from the stationary contacts, separating the main contacts '109', and '121', first. As the arcing contacts open under load, an arc is drawn. The end of this arc on the stationary arcing contact then moves up to the blowout magnet contact '144', putting the blowout magnet coil '137', in series with the arc. Flux from the blowout magnet forces the arc up into the arc chute where it is extinguished. As the circuit breaker closes, first the arcing contact surfaces touch, and then the main contacts touch.

2. Description

The stationary contact assembly consists of the main contact, extruded integral with the upper stud '120', and the arcing contact '123'. The stationary arcing contact surfaces of the stud '121', and the contact '123' are special arc-resisting silver-alloy inserts. The moving contact assembly consists of a contact arm, '175', which is pivoted to the pole unit by a pin '127', and carries the main moving contact '109', and the moving arcing contact '118'. The auxiliary contact '176', serves as a connector from the main moving contact to the upper terminal of the series coil of the overcurrent tripping device. The moving contact assembly is attached to the mechanism crossbar '168', Fig. 3, by a molded insulating link '116', which is screwed on to a metal link '111', and locked by a nut '114'. When the breaker is tripped, all force is removed from the crossbar, and the accelerating springs '131', quickly force the moving contact assembly from the closed to the open position.

3. Replacements (Fig. 4)

(a) To replace the stationary arcing contact '123', or the spring '184': Remove the arc chute '135', by removing the screws '147'. Remove the two bolts holding the contact assembly and replace either it or the spring as required.

(b) To replace the moving arcing contact '118': Remove the arc chute '135', by removing the screws '147'. Remove the bolts '112', which will free the contact for replacement.

(c) To replace the blowout magnet contact '144': Remove the arc chute '135', by removing the screws '147'. Remove the two screws through the back of the arc chute which secure the contact. Replace the contact.

(d) To replace the main contact spring '182': Remove the arc chute '135', by removing the screws '147'. Release the spring in the contact arm '175', by rotating the locking clip in the spring seat with a screwdriver or with the fingers.

(e) To replace the accelerating spring '131': Remove the arc chute '135', by removing the screws '147'. Work the springs out of their sockets with a screwdriver.

(f) To replace the auxiliary contact springs '183': Remove the arc chute '135', by removing the screws '147'. Work the springs out with a screwdriver and replace. If difficulty is experienced, loosen the moving contact arm hinge loosening the bolts in vicinity of the lower stud holding the overcurrent trip and contact arm hinge.

c. OPERATING MECHANISM (Fig. 5 and 6)

1. Function

The operating mechanism opens and closes the circuit breaker contacts by moving the cross bar (168) Fig. 3 to which the moving contact assemblies are attached by insulating links. The breaker is closed manually by turning the operating handle quickly and smoothly as far as it will go (90°) in a clockwise direction. The breaker may be tripped manually by turning the handle 45° in a counterclockwise direction. Handle latch (233) must be held in while closing or tripping. The breaker is tripped automatically by one of the automatic devices described later which rotate trip lever (220) about pin (224).

The mechanism is "trip free", that is, it is not possible to close the breaker if one of the automatic tripping devices moves the trip bar up during the closing stroke or if the trip bar (157) Fig. 3 is held in the raised position.

2. Description

The operating mechanism consists of a group of toggle links, and a latch attached to the operating mechanism frame on fixed pins (214), (226), (241), (216), (224) and (245). The cross bar (168) is held by the closing lever (207). Rotating the operating handle clockwise moves the mechanism linkage from the open position shown in Fig. 6 to the closed position shown. This is accomplished when the roller (236) located off-center on the end of the operating handle shaft (232) forces the first toggle link (203) upward pushing second toggle link (204), third toggle link (206) and closing lever (207) ahead of it. The motion of the toggle linkages is directed by link (205) which is pivoted at its lower end on pin (217) in latch (208). Latch (208) in turn is restrained from moving by roller latch (210) which is pivoted

on pin (214) and engages trigger (221), on trip lever (220). The linkage is held in the closed position by pawl (209) which latches under pin (227). The handle shaft and lever are returned to the normal position after closing by gravity.

The mechanism is opened by rotating trip lever (220) counterclockwise. This is accomplished either by rotating handle counterclockwise, in which case roller (236) on the end of handle shaft lever strikes the extreme left end of trip lever (220) to move it downward; or by causing tripping attachments to strike trip finger screw (243) or trip bar (157) Fig. 3. In either case the counterclockwise rotation of the trip lever (220) moves trigger (221) out of engagement with the lower end of the roller latch (210) which in turn permits the roller latch to rotate counterclockwise out of engagement with latch (208). Latch (208) is then free to rotate in response to the pull of the latch link (205) so that the mechanism assumes the trip free position shown in Fig. 6 in which contacts are open but part of the mechanism levers are in the closed position. In this position pawl (209) is disengaged from pin (227) by a lug on link (204) which pushes it up permitting the linkage to collapse to the open position shown in Fig. 6.

Gravity returns operating handle to the normal vertical position after manual tripping.

3. Anti-Bounce Latch

The anti-bounce latch (234) prevents the breaker from bouncing closed when interrupting short circuit current. As breaker opens pin (238) strikes latch (234) pivoted on pin (237), rotating the latch until its hook is in position to hold pin (238) from bouncing to the closed position.

4. Position Indicator

Position indicator (230) is formed from sheet metal and is pivoted on pin (241). It is visible from the front of the circuit breaker through a window in the housing and mechanism frame. See Fig. 3. With the circuit breaker in the open position shown in Fig. 6, the amber face of the indicator shows through the window. The word "OPEN" is stamped on this amber face. When the breaker closes, pin (218) of the closing lever (207) pulls indicator link (228) to the right, thus rotating the other face of the indicator up into a position visible through the window. This face is painted blue and is stamped with the word "CLOSED".

5. Replacements

To replace roller latch spring (223):

- (a) Disconnect auxiliary switch links.
- (b) Rotate handle (166) clockwise until pin (227) is visible through the right side of mechanism frame. Using a small rod as a pusher, shove this pin part way through the hole until the operating rod of the closing magnet drops off. Return pin (227) to its proper location and allow the linkages to fall open. This frees the mechanism from the closing magnet.
- (c) Remove crossbar (168) Fig. 3. Remove the four bolts which hold mechanism to the shelf (152) Fig. 3. This frees mechanism from shelf but frees also the closing magnet. This should be either replaced or blocked in place during repairs to the mechanism.

- (d) Removal of pin (224) allows trip lever (220) to be removed and spring (223) may then be replaced.

To replace handle stop spring (248):

- (a) Remove handle (166) and handle latch (233) and replace spring (248).

To replace pawl spring (225):

- (a) This spring may be replaced without further ado after removing mechanism cover (239).

d. ANTI-SHOCK-CLOSE DEVICE (Fig. 7)

1. Function

This device serves to prevent the circuit breaker contacts from closing from shock when open. This is accomplished by an arrangement whereby a mechanical escapement device or "ticker" is operated by the closing of the breaker. Shock blows tending to close the breaker are of such short duration that the mechanical escapement device does not have time to operate, thereby effectively locking the circuit breaker in the open position. This mechanical escapement device is, however, easily overcome when the circuit breaker is operated normally.

2. Description

The anti-shock-close device consists of a ticker case '360', Fig. 7, which contains the ticker assembly, bolted to the closing magnet. An arm '384', is bolted to the moving core '342' of the closing magnet, and when the moving core moves up, a cam '361', is caused to rotate in a clockwise direction around a pin '370', against the torsion of the reset spring '369'. As the cam rotates in this manner, an oscillator wheel '362', is caused to rotate clockwise around a pin '372', by a pin '368', mounted in the cam '361'. The rotation of the wheel '362', is regulated by a mechanical oscillator '364', which is pivoted on a pin '365', and caused to oscillate due to the engagement of its teeth by the oscillator wheel '362'. When the circuit breaker is tripped, operating rod '343', drops unimpeded, and a reset spring '369', returns the cam '361', to the breaker "OPEN" position shown in Fig. 7. Shock blows tending to close the circuit breaker would have to act in such a way as to raise the operating rod '343'. These blows are of such short duration that the cam is restrained long enough by the oscillator wheel and the oscillator to prevent closure of the circuit breaker.

3. Replacements

To replace the reset spring '369': Remove device from the closing magnet yoke '340', by removing the bolts '374'. Remove the "Truarc" rings '367, 371, and 373' which will allow the corresponding pins to be removed. The various parts are then free to be removed, and the spring may be replaced. After reassembling, be sure that the cam operated freely and returns easily to its starting position.

e. CLOSING MAGNET OF SOLENOID (Fig. 7)

1. Function

The closing magnet is the device used to close the circuit breaker electrically from the control board. Mounted directly below the operating mechanism and under the shelf of the

circuit breaker, it is secured to the shelf with the same four bolts that hold the operating mechanism in place.

2. Description

The closing magnet consists of an iron frame or yoke '340', which is securely bolted to the circuit breaker shelf by four bolts '349', a plunger or moving core '342', an operating rod '343', a stationary core '341', and a coil '347'. The operating rod '343', connects the moving core '342', to a pin '227', Fig. 6, on the operating mechanism. It will be observed in Fig. 6 that an upward movement of this pin will cause the mechanism to close and latch the circuit breaker. When the coil '347', of the closing magnet is energized by the relay '300', Fig. 3, the moving core '342' moves upward in response to the magnetic attraction between stationary and moving cores, across an air gap. About one-tenth of a second is required for the closing magnet to close and latch the circuit breaker. When the moving core moves into the breaker "CLOSED" position, the trip bracket '359', trips the relay mechanically, thus opening its contacts and de-energizing the closing magnet. The trip bracket '359', in moving up, lifts the trip rod '357', which rotates the trip arm '356' against the force of a spring '355'. This rotation of the trip arm '356', engages the trip finger '327', Fig. 8, of the closing relay and trips the relay. The closing coil '347', is momentarily rated and serious damage will result if potential is allowed to remain on its terminals through improper adjustment of the trip finger '327', Fig. 8, of the closing relay. When the moving core and operating arm have pushed the mechanism linkages to the closed and latched position, a pin '227', Fig. 6, holds the moving core in the closed gap position. When the mechanism is tripped, this pin '227', Fig. 6 falls, allowing the operating arm and all moving core to fall with it.

3. Replacements

(a) To replace the closing coil '347': Remove the arm '348', by removing bolts '351'. Remove the plate '346', by removing four bolts '350'. Remove the coil leads and replace coil.

(b) To replace the spring '355': Remove the closing relay '300', Fig. 3, as described in the paragraph below. Remove the snap ring from pin '358', and slide the relay trip arm '356' off.

f. CLOSING RELAY (Fig. 8)

1. Function

The closing relay is mounted on the underside of the breaker shelf to the left of the closing magnet. The relay has the function of closing and opening the closing coil circuit in electrical operation. Together with the shunt trip, the closing relay enables the operator to have remote control of the circuit breaker electrically by means of a control switch, from the control board.

2. Description

(a) The relay base '300', is molded from insulating material. The contact assemblies, coil assembly, and other parts are attached to this base. The frame '305', serves as part of the magnetic circuit of the coil '338', and also serves to hold the coil in place. This frame or yoke is fastened to the molded base by three screws '318'. The coil '338', is wound on a molded spool '339', and is held in place by a guide tube '337', which extends from the top of the molded base through the bottom of the frame '305', and through the center of the spool.

At its upper end, the guide tube '337', holds the stationary core '306' firmly in place against the frame. The moving core '333', is free to slide up and down in the guide tube '337'.

(b) When moving up, in response to the magnetic pull between the stationary and moving cores when the coil is energized, it pulls the latch '336', fastened to a pin '335', up with it. When the coil '338', is energized, a spring '334', bearing against the latch '336', holds the latch in such a position that it is hooked under a latch pin '316'. This causes the moving contact arm assembly '301', to rotate counterclockwise around the contact arm pin '329', thereby compressing a spring '312'. The moving contacts '303', are thus pulled against the stationary contacts '304', completing the circuit. In Fig. 8, the moving core is shown in the upper "contacts closed" position.

(c) As soon as the contacts close, current starts flowing through the closing coil of the circuit breaker. The moving core '342', Fig. 7, of the closing magnet moves up, closing the circuit breaker. The trip bracket '359', moves up with the moving core of the closing magnet and engages a trip rod '357'. The trip rod rotates the relay trip arm '356', around a pin '358', against the force exerted by the spring '355'. The relay kicker in rotating, engages the relay trip finger '327', Fig. 8, to lift it and trip the relay as described below. The trip finger '327', is fastened to a release bracket '308', and rotates it counterclockwise around a pin '317', against the torque exerted by the torsion spring '313'. When the release bracket '308', is rotated in this manner, it strikes the bottom of a latch '336', rotating it counterclockwise around a pin '335', against the force of the spring '334'. This rotation of the latch '336', causes it to become disengaged from the latch pin '316'. Consequently the spring '312', extends, causing the moving contact assembly '301', to rotate clockwise, snapping the moving contacts '303', away from the stationary contacts '304', and interrupt the circuits.

(d) With the circuit breaker in the closed position the relay trip arm '356', Fig. 7, of the closing magnet holds the trip finger '327', Fig. 8, of the relay in the trip position. Therefore, even though the relay coil may be inadvertently energized when the circuit breaker is latched, the relay contacts will not close, and current will not flow through the circuit breaker closing coil. The moving contacts, '303', Fig. 8, are resiliently mounted by means of springs '314', around studs set into the moving contact arm '301', and are secured by elastic stop nuts '315'. This causes a slight rolling and wiping action on the spherically-shaped contact surfaces as they meet, which helps to insure a positive electrical connection.

(e) An arc chamber '310', molded from arc-resisting material, surrounds the left-hand contacts. It is held in place by means of the two iron plates of the blowout magnet assembly '302', which in turn is fastened to the molded base '300', by means of a screw '323'. The blowout magnet coil is connected in series with the left-hand contacts, so that flux is flowing through the magnetic circuit, and the air gap of the blowout magnet assembly, at the time the contacts part and draw an arc. The magnetic circuit is so arranged that its air gap is across the arc chamber and the arc. The arc is forced by magnetic action down into the arc chamber, where it is extinguished due to the stretching and cooling process.

NOTE: The right-hand contacts are not used.

DANGER

Before working on the relay, make sure that the circuit breaker is open and that the upper and lower studs are dead. Be sure that the control circuits are dead. Remember that control wiring may be "hot" even though the main circuit breaker studs are dead.

3. Replacements

(a) Before replacing parts of the relay, it is best to disconnect the wiring and remove the relay from the circuit breaker as follows: Remove screw '322', Fig. 8, and lift off the molded cover '309', of the relay thus exposing the four numbered terminals. Remove and tag the wires from the four terminals by loosening the four screws '320'. Remove the front cover of the auxiliary switch and disconnect the relay coil lead. Remove the two screws through the circuit breaker shelf '152', Fig. 3, which hold the relay to the shelf. The relay can now be removed.

(b) To replace the relay coil: Remove the three screws holding the coil frame '305', Fig. 8, to the molded base '300', and remove from base. Pull out the guide tube '337', allowing the stationary core '306', to drop out. Replace coil.

(c) To replace the latch spring '334': Remove the three screws holding the coil frame '305', to the base '300'. Pull out the guide tube '377', and stationary core '306'. Lift out the moving core assembly '333'. Rotate the latch '336', clockwise as far as it will go. A spring '334', will drop out. Be sure it is replaced.

(d) To replace the trip spring '313': Remove the snap ring from one end of the release bracket pin '317', and push the pin out. Replace the pin and a new spring.

(e) To replace the moving contact arm spring '312': Remove the snap ring from one end of the contact arm pin '329', and push pin out. Remove the moving contact arm assembly '301', and replace the spring '312'.

(f) To replace the moving contact '303', or contact spring '314': Remove the elastic stop nut '315', and replace the spring (if necessary). If a moving contact is to be replaced, disconnect its lead from under the applicable terminal screw '319'. Remove and replace it.

(g) To replace the blowout magnet assembly: Disconnect leads of the blowout coil. Remove the screw '323', and replace the blowout magnet assembly.

(h) To replace the stationary contact assembly: If left-hand contact is to be removed, it will be necessary to remove the blowout magnet assembly as outlined above. Remove the applicable screw '321', and replace the contact.

g. ANTI-SHOCK-OPEN DEVICE (Fig. 9)

1. Function

The anti-shock-open device prevents tripping of the circuit breaker from rotation of the trip lever caused by shock, but allows rotation of the trip lever by tripping devices.

2. Description

The bracket '250', Fig. 9, is mounted on the breaker shelf to the immediate right of the operating mechanism frame '200', Fig. 3, and is held to the shelf by two screws '256', Fig. 9. The plate '252', is pivoted on a pin '253', as is the lever '268'. The lever and plate are connected by a setscrew '269', in such a way that if the trip bar '157', Fig. 3, and Fig. 9, rises, the lever '268', rotates counterclockwise around the pin '253', causing the plate '252', to rotate in the same direction. Conversely, if the plate '252', is restrained

from rotating, the trip bar is held down by the lever '268'. Under shock conditions, the plate '252', is restrained from moving in the following manner: The studs '255 and 258', are suspended on pin '251'. The plate '252', contains a slot in its end, arranged so that the plate will slide down over the studs '255', and allow the circuit breaker to trip under normal tripping impulses. Under shock conditions, however, the two outboard studs are caused to rotate around the pin '251', due to the offcenter weights '257', and thus block the plate '252' preventing it from sliding down. The middle stud is actuated by a separately pivoted weight '267', which rotates about pin '264'. A spring '263', serves to hold the weight in the proper position during normal operation as shown.

3. Replacements

(a) To replace the reset spring '262': Remove the cover screws '271' and cover. Remove the device from the shelf by removing screws '256'. Remove the pin '253', and replace the spring '262'.

(b) To replace the weight spring '263': Remove the cover screws '271', and cover. Remove the device from the shelf by removing screws '256'. Remove the pin '264', which will free the weight '267', and allow the weight spring '263', to be replaced.

4. Adjustments

With the device mounted on the breaker shelf, the lever '268', should be adjusted by means of a lock nut '270', and setscrew '269', so that it bears down slightly on the trip bar '157'

h. SERIES-OVERCURRENT-TRIP DEVICE (Figs. 10 and 11)

1. Function

The series-overcurrent-trip device trips the circuit breaker automatically under two distinct conditions of overcurrent. For overcurrents greater than the short-time delay pickup settings, but less than the instantaneous pickup setting, the device will trip the breaker after a purposely introduced short time delay. For overcurrents greater than the instantaneous pickup setting, the device will trip the breaker instantaneously. Refer to Fig. 10 for the characteristic curves of the trip units.

2. Description (Fig. 11)

(a) The overcurrent trip device consists of an electromagnet connected in series between the moving contact assembly of the pole unit and the lower stud. Under overcurrent conditions, the tube assembly '440', Fig. 11, rises, picks up the trip finger '242', and trips the circuit breaker. The tube assembly '440', is non-magnetic except for the armature '455'. An iron yoke '457', carries flux from the bottom of the armature '455', back to the top of the armature. When the overcurrent becomes high enough to exceed the calibration setting, the armature '455' moves up, pulling toggle and lever assembly '459', up with it by means of pin '472'. The roller '464', bears on an end ring '467', which in turn pushes the tube '477', up and trips the circuit breaker.

(b) The calibration spring '410', is connected to the toggle and lever assembly through a system of linkages, and serves to hold the armature '455', down until an overcurrent causes a magnetic pull great enough to extend them. The lever '459', is pivoted on a pin '463', and

connected through the instantaneous spring '420', to the gear segment '460', which operates the pinion '474', and oscillator wheel '461', on the same shaft. The oscillator wheel is restrained from free rotation by the oscillator '462'. This restraining action provides a short time delay. With fault currents of greater magnitude than the instantaneous pickup setting, the instantaneous spring '420', extends, and the tube assembly '440', rises and trips the circuit breaker instantaneously, unimpeded by the mechanical escapement device.

3. Replacements

NOTE: Any field replacements on the overcurrent-trip device should be regarded as temporary, pending recalibration at the factory.

(a) To replace the calibration springs '410': Remove the bolts '451 and 478', which frees the device from the breaker. Remove the insulating cover '484', by removing the screws '475 and 495'. The calibration springs '410' are now accessible for replacement.

(b) To replace the instantaneous spring '420': Remove the bolts '451 and 478', to free the device from the breaker. Remove the insulating cover '484', by removing screws '475 and 495'. Remove the housing '458', from the yoke '475', by removing screw '273'. Loosen the adjusting screw '469', and replace the spring '420'. Center-punch the arm '456', lightly near the screw after replacement for locking purposes.

4. Adjustments

The scale plate '493', is marked for short-time-delay pickup as per contract. The adjusting knob '492' can be used to raise or lower the short-time-delay pickup point, if desired. Moving the pointer down increases the pickup current, and moving it up decreases the pickup current, by increasing or decreasing tension in the calibration spring '410'.

I. AUXILIARY SWITCH (Fig. 12)

1. Function

The auxiliary switch is used to close or open the auxiliary or control circuits. The closed or open positions of its groups of contacts, are coordinated with the closed or open positions of the main circuit breaker contacts as described under Paragraph (2).

2. Description

The four-pole, type "RC" auxiliary switch is mounted on the top of the supporting frame shelf, to the left of the operating mechanism. The switch is a shaft-operated, rotary type, having three "a" contacts and one "b" contact. An "a" contact is one that is open when the circuit breaker is open; a "b" contact is one that is closed when the circuit breaker is open. Terminals "1-2, 3-4, and 5-6" connected to type "a" contacts, and terminals "7-8", connect to type "b" contact. The contacts are designed to carry 15 amperes continuously, or 250 amperes for three seconds. The switch is operated by an arm '557', attached to a square shaft '555', extending through the rotor molds '560'. The molds serve to isolate and support the rotor contacts '562'. The rotor assembly is clamped together into a solid unit by a screw '564'. The rotor contacts are set for 90 degree rotation of the shaft '555'. Contact fingers '553', have one end hooked into the stem '551', with the spring '552', maintaining pressure between the finger contact and stem. The center of the contact finger bears against a stop surface in the casing, to position the outer end of the contact finger.

3. Replacement

To replace the auxiliary switch: Remove and tag the terminal connections. Disconnect the arm '557', from the breaker lever. Remove the two mounting bolts, and remove the switch. Remove the arm from closing lever and add to the new switch.

j. SHUNT-TRIP DEVICE (Fig. 13)

1. Function

The shunt-trip device serves as a means of tripping the circuit breaker by closing a control switch on the power control board.

2. Description

The shunt-trip device is mounted on the left side of the supporting frame shelf. See Fig 3. It consists of a frame, coil and moving core, all mounted horizontally. The energizing trip coil '513', Fig. 13, sets up a magnetic attraction between stationary core '503', and moving core '504'. This attraction causes the moving core to move to the left, rotating the trip lever '501', about the pin '502'. The lever '501', raises the trip bar '157', to trip the circuit breaker. The opening of the circuit breaker de-energizes the shunt trip coil through an "a" contact of the auxiliary switch. A spring '508', returns the moving core '504' to its normal position. The non-magnetic washer '510', prevents residual magnetism from holding the cores together when the coil is de-energized.

3. Replacements

(a) To replace the coil '513': Disconnect the shunt-trip leads from the auxiliary switch. Take out the two bolts '515' and remove the shunt-trip assembly from the supporting frame. Remove the pin '502', and screws '509', holding the plate '505' in place. Drop out the moving core '504', washer '510', stationary core '503', and sleeve '507'. The coil is then free to be replaced.

(b) To replace the spring '508': Disconnect the shunt-trip leads from the auxiliary switch. Take out two bolts '515', and remove the shunt-trip assembly from the supporting frame. Remove the pin '502', and replace the spring '508'.

k. UNDERVOLTAGE TRIP (Fig. 14)

1. Function

The undervoltage trip device mounts on top of the shelf (platform), to the right of the anti-shock open device. Its function is to trip the breaker when the voltage falls between 10 to 40 per cent of normal (25 to 100 volts d.c.).

2. Description

The moving core (804) is normally held magnetically against the stationary core (803) to hold the plunger (816) and consequently the reset lever (815) in the reset position. When the coil (801) voltage is reduced sufficiently, the reset lever spring (812) overcomes the magnetic attraction of the cores and rotates the reset lever clockwise. As the reset lever rotates, th

reset lever pin (827) pushes against the latch (805) to release it from its latch plate (819). When the latch releases, the trip spring (811) rotates the trip lever (808) counterclockwise to trip the breaker. The linkage is reset by the cross bar (168) as the breaker opens.

In order for moving core (804) to move and trip breaker as described above, lever (324), wheel (822), and ticker (823) must be moved. Rotation of wheel and oscillation of ticker introduces a small time delay which prevents shock from parting the magnetic cores.

To check the mechanical operation of the undervoltage trip device de-energize the coil and hold the trip bar down. Close the breaker manually and release the trip bar slowly, allowing the undervoltage trip lever to raise the trip bar and open the breaker.

3. Replacement

To replace voltage coil (801):

- a. Remove undervoltage trip device from breaker by disconnecting the coil leads and removing the two 5/16 mounting bolts.
- b. Remove bracket (821) by removing screws (829) and (830) and pin (831).
- c. Remove rear cover (820) by removing the two mounting screws. Moving core (804) and tube (802) can now be removed.
- d. Remove stationary core (803) by removing screw (828). Plunger (816) can now be disengaged from reset lever (815).
- e. Voltage coil is now free to be replaced.

4. Repair Parts

The repair parts shown in table below were included with the undervoltage trip devices.

To replace springs (807), (811), (812), and (814):

- a. Remove undervoltage trip as above.
- b. Remove proper pins and replace spring.

1. REVERSE CURRENT TRIP (Fig. 15)

1. Function

This device has application on direct current breakers only. It will instantaneously trip the circuit breaker when the current flows in its series coil in the reverse direction and exceeds the calibration setting. This device is set and marked in amperes at the factory, at 5 percent or more of the rated continuous current of the circuit breaker overcurrent trip coils.

2. Description

This device (600) is mounted on the center insulating base of a two pole breaker and the top terminal of its current coil is connected to the upper stud of the circuit breaker. A

copper connector connects the upper stud to the lower stud of the right hand pole. Thus the series coil (624) of the reverse current trip device is connected in series with the right hand pole overcurrent trip coil.

The potential coil (623) is connected directly across the line through an "a" contact of the auxiliary switch. This demagnetizes the armature (603) when the breaker trips on a reverse current and permits calibration spring (612) to reset it.

The main structural parts of the device consist of a yoke (600), a pole piece (601), a core (610) and an armature (603), all of magnetic steel. Bearing casting (602) of non-magnetic material is drilled for pin (621) about which armature (603) has a limited freedom of rotation. If armature (603) rotates counterclockwise, it pulls pin (619) and link (606) with it. After link (606) has traveled some distance, the slot in its end engages pin (622) of trip lever (605) and moves it to the left. This causes trip lever (605) to rotate clockwise about fixed pin (620) in bearing casting (602). This rotation causes the trip lever (605) to move breaker trip screw up thus causing the circuit breaker to trip.

Each of the coils of the device, the potential coil (623) and the series coil (624), has its own magnetic circuit. With forward current flowing in series coil (624), pole B is a south pole, say, and pole A, is a north pole. At the bottom of the magnetic circuit of series coil (624), pole D is a north pole and pole C is a south pole as far as the series coil magnetic circuit is concerned. In the potential coil magnetic circuit, pole E is a north pole and pole C is a south pole as far as the potential coil magnetic circuit is concerned. It can be seen that under the circumstance of forward current flow in the series coil, the magnetic pull between unlike poles C and D will hold armature (603) immobile since pole C is a strong south pole due to flux from both coils while pole D is a north pole due to flux of series coil.

When the current in series coil (624) reverses, poles A and B change their polarity to south and north respectively, and pole D changes to a south pole. Since pole E is still a north pole due to the potential coil, there is now an attraction between poles D and E where repulsion existed before. Pole C is still a south pole as far as the potential coil is concerned but has become a north pole with respect to the series coil. The net result is that pole C becomes very weak and as soon as the attraction between unlike poles A and B and the attraction between unlike poles D and E becomes strong enough to overcome the tension in calibration spring (612), the armature rotates counterclockwise and trips the circuit breaker as described before.

This device is set at the factory and should not be tampered with in the field. However, it may be necessary to make a field adjustment in case calibration spring (612) has been replaced.

- (a) Remove two screws in nameplate and remove nameplate from device.
- (b) Remove locking piece (609).
- (c) Calibration screw (613) has a square cross section and may be turned with a small wrench. Turning screw (613) so that arm (608) moves down increases the calibration setting of the device and turning it the other direction decreases the setting. The screw should be set so that the amount of reverse current indicated on the nameplate will just trip the circuit breaker.

By the addition of an air dashpot, a reverse current with delayed tripping can be supplied. When armature (603) attempts to move counterclockwise, pin (636) will restrict motion

until latch (635) is free, as latch (635) moves to right it rotates lever (630) counterclockwise about pin (647) moving pin (628) and compressing diaphragm (632), the amount of delay in this motion is determined by the orifice leading into filter (640). After lever (630) has rotated far enough to free latch (635); latch (635) and armature (603) move unrestricted to trip breaker.

The amount of delay is factory set by setting of screw (638) which controls the orifice and screw (645) which controls the engagement of latch (635) with lever (630). Any field adjustments should be limited to screw (638). Turning screw (638) a slight amount clockwise will increase delay.

3. Replacements

Remove wiring and then reverse current by removing bolts (642).

To replace calibration spring (612): This can be done directly without removing other parts.

To replace potential coil (623):

- (a) Remove nameplate, screw (613), and screw (611).
- (b) Loosen screws (627), tilt yoke (600) away from coil, and pull coil (623) off boss on pole piece (601) and replace.

To replace latch reset spring (637):

- (a) Remove coil (623) as above.
- (b) Remove pin (636) and replace spring (637).

To replace diaphragm (632) or diaphragm spring (648):

- (a) Remove screws (641) and slide spacers (618) and cover (631) down until lever (630) disengages pin (628).
- (b) Diaphragm (632) and diaphragm spring (648) are now accessible for replacement.

m. MECHANICAL INTERLOCK (Fig. 16)

1. Function

The mechanical interlock allows only one of two breaker to be closed at one time and when one breaker is closed renders the other breaker "trip free" so as to prevent over stressing of parts that might occur if attempts were made to close a blocked breaker.

2. Description

A cam for each breaker is rigidly fastened to a common bar forming cam assembly (842). As cross bar (168) of one breaker moves to the breaker closed position, the cam assembly rotates in bushing (849) so as the cam for the other breaker blocks the cross bar of the other breaker. A view of how each breaker blocks the other is shown in the small views above the main assembly figure.

When either breaker closes links (843) cause tripper assemblies (844) to rotate. Tripper assembly (844) of breaker being closed will rotate away from trip bar (157) while tripper assembly (844) of other breaker will lift its trip bar (157) causing the breaker to be "trip free". When both breakers are open plungers (845) which are spring loaded by springs (847) returns cam assembly to neutral position.

The neutral position of cam assembly (842) can be adjusted by moving bushing (846) up or down and tripper assembly (844) can be adjusted by screws (850).

3. Replacement

To replace spring (847); remove nuts on plunger (845) and bushing (846). Spring (847) can now be replaced by rotating cam assembly (842) and removing plunger and bushing.

n. REPAIR PARTS

Potential coils, springs, arcing contacts, and auxiliary switches are supplied as repair parts. For style number identification refer to certification data sheets listed on page 1.

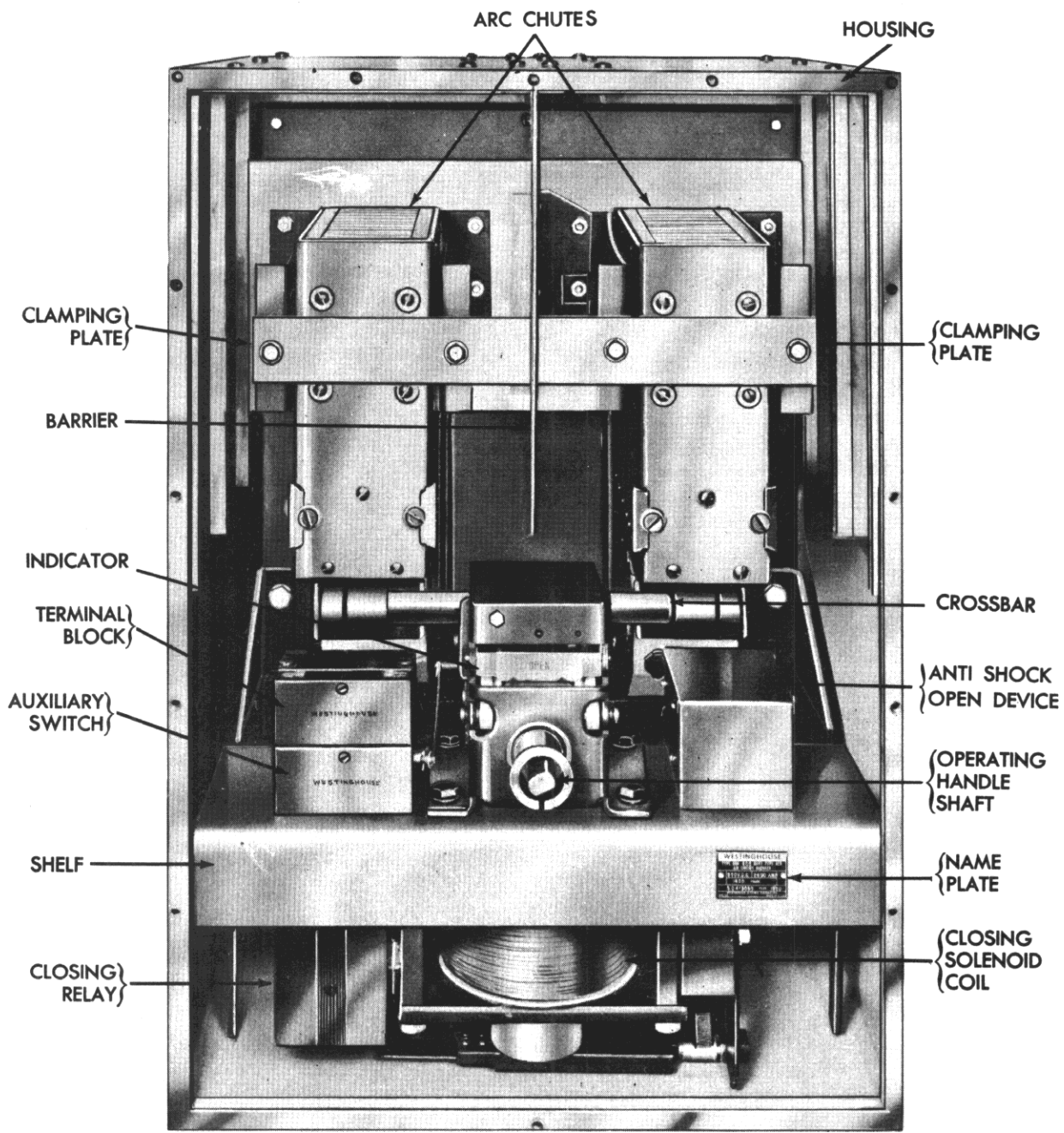

Fig. 1 - Front View of Breaker

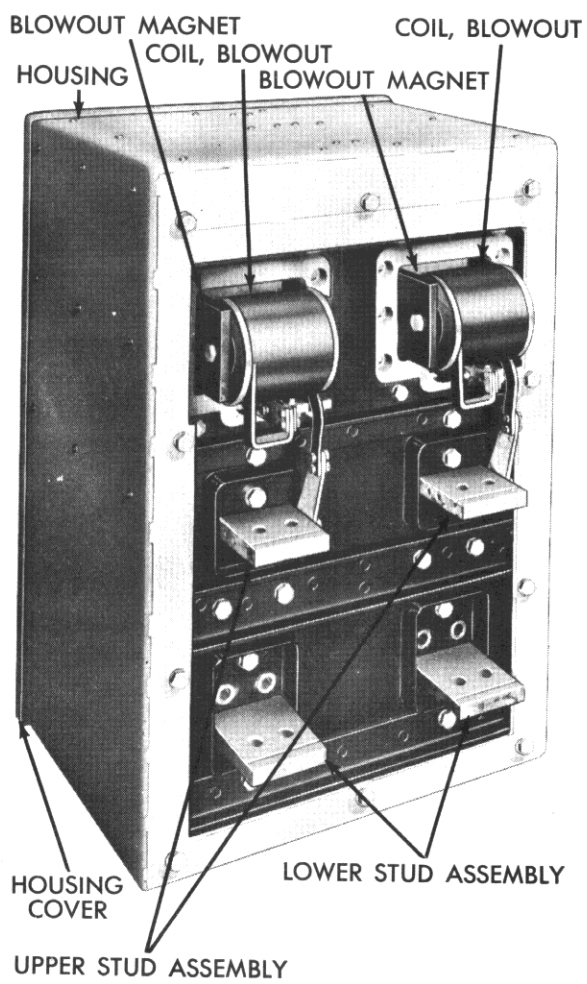
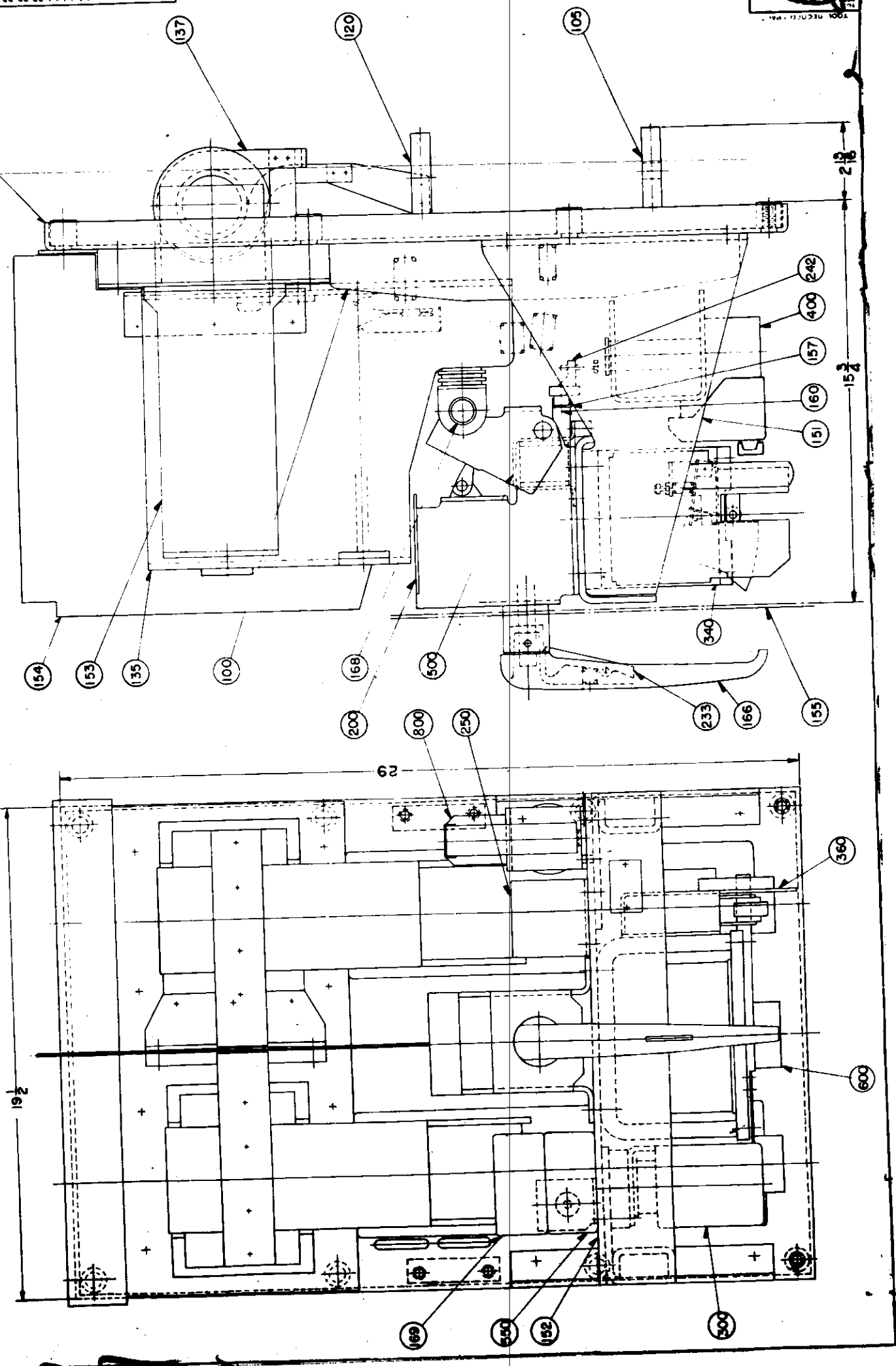
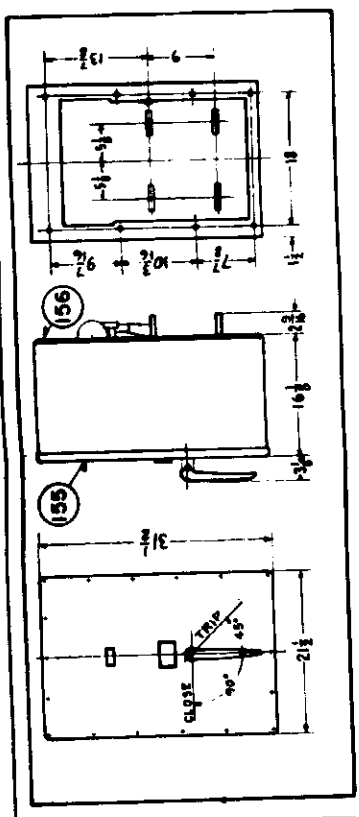

Fig. 2 - Rear View of Breaker

- 100 MOLDED BASE
- 105 LOWER STUD
- 120 UPPER STUD
- 135 ARC CHUTE
- 137 COIL, BLOWOUT MAGNET
- 150 STEEL PANEL
- 151 SUPPORTING FRAME
- 152 SHELF
- 153 POLES, BLOWOUT MAGNET
- 154 BARRIER
- 155 HOUSING COVER
- 156 HOUSING
- 157 TRIP BAR
- 160 ELASTIC STOP NUT
- 166 OPERATING HANDLE
- 168 CROSS BAR
- 169 TERMINAL BLOCK
- 200 MECHANISM
- 233 HANDLE LATCH
- 242 TRIP FINGER
- 250 ANTI-SHOCK-OPEN DEVICE
- 300 CLOSING COIL CONTACTOR
- 340 CLOSING MAGNET
- 360 ANTI-SHOCK-CLOSE DEVICE
- 400 OVERCURRENT TRIP
- 500 SHUNT TRIP DEVICE
- 550 SWITCH, AUXILIARY
- 600 REVERSE CURRENT TRIP
- 800 UNDERVOLTAGE TRIP

Fig. 3

WESTINGHOUSE ELECTRIC CORPORATION
 ACB TYPE DBN-625 (228)
 GENERAL ASSY. FOR INSTRUCTION BOOK
47A65
 PROY. DEV. 51



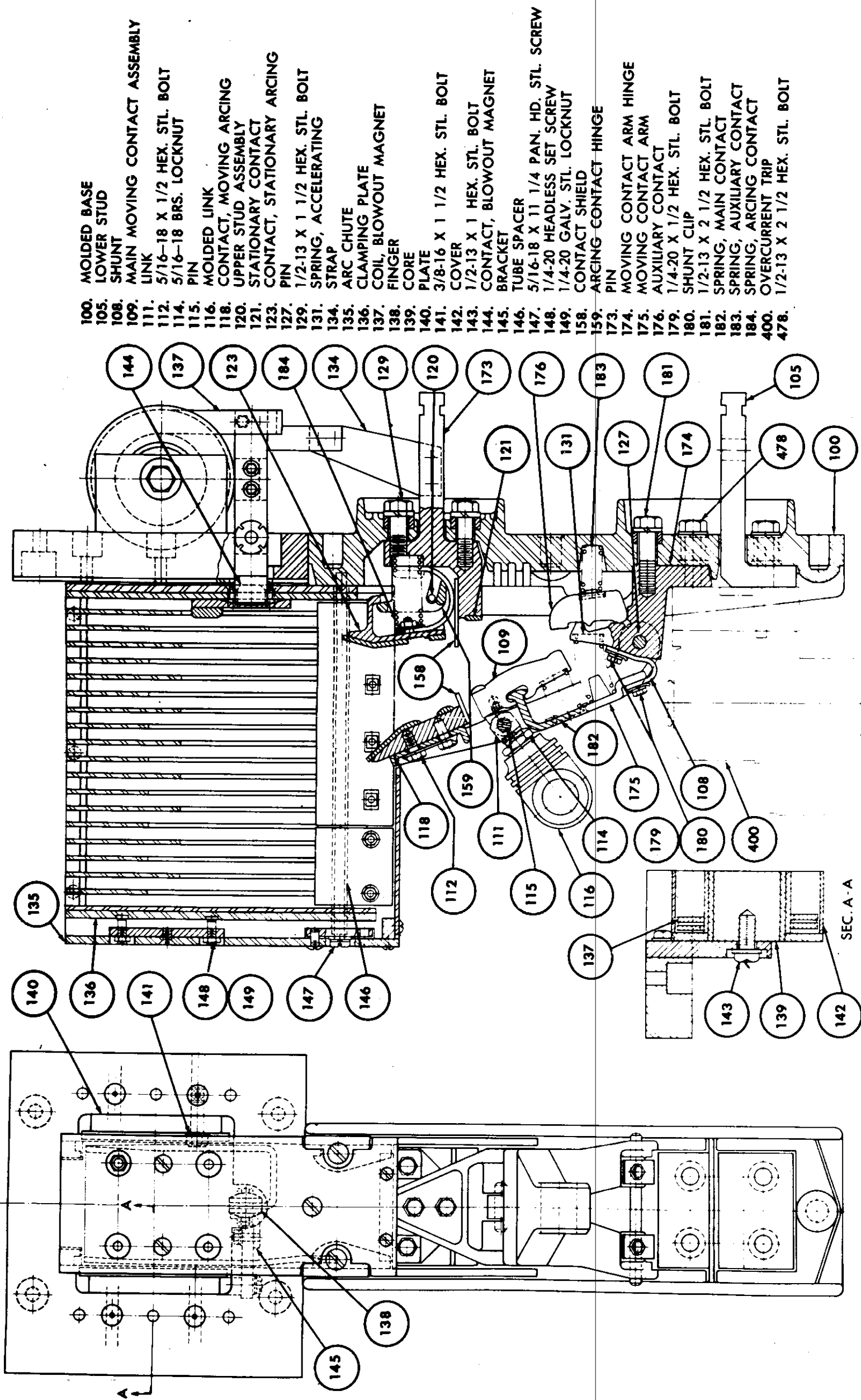

- 100. MOLDED BASE
- 105. LOWER STUD
- 108. SHUNT
- 109. MAIN MOVING CONTACT ASSEMBLY LINK
- 111. 5/16-18 X 1/2 HEX. STL. BOLT
- 112. 5/16-18 BR5. LOCKNUT
- 114. PIN
- 115. MOLDED LINK
- 116. CONTACT, MOVING ARCING
- 118. UPPER STUD ASSEMBLY
- 120. STATIONARY CONTACT
- 121. CONTACT, STATIONARY ARCING
- 123. PIN
- 127. 1/2-13 X 1 1/2 HEX. STL. BOLT
- 129. SPRING, ACCELERATING
- 131. STRAP
- 134. ARC CHUTE
- 135. CLAMPING PLATE
- 136. COIL, BLOWOUT MAGNET
- 137. FINGER
- 138. CORE
- 139. PLATE
- 140. 3/8-16 X 1 1/2 HEX. STL. BOLT
- 141. COVER
- 142. 1/2-13 X 1 HEX. STL. BOLT
- 143. CONTACT, BLOWOUT MAGNET
- 144. BRACKET
- 145. TUBE SPACER
- 146. 5/16-18 X 11 1/4 PAN. HD. STL. SCREW
- 147. 1/4-20 HEADLESS SET SCREW
- 148. 1/4-20 GALV. STL. LOCKNUT
- 149. CONTACT SHIELD
- 158. ARCING CONTACT HINGE
- 159. PIN
- 173. MOVING CONTACT ARM HINGE
- 174. MOVING CONTACT ARM
- 175. AUXILIARY CONTACT
- 176. 1/4-20 X 1/2 HEX. STL. BOLT
- 179. SHUNT CLIP
- 180. 1/2-13 X 2 1/2 HEX. STL. BOLT
- 181. SPRING, MAIN CONTACT
- 182. SPRING, AUXILIARY CONTACT
- 183. SPRING, ARCING CONTACT
- 184. OVERCURRENT TRIP
- 400. 1/2-13 X 2 1/2 HEX. STL. BOLT
- 478. 1/2-13 X 2 1/2 HEX. STL. BOLT

9-10

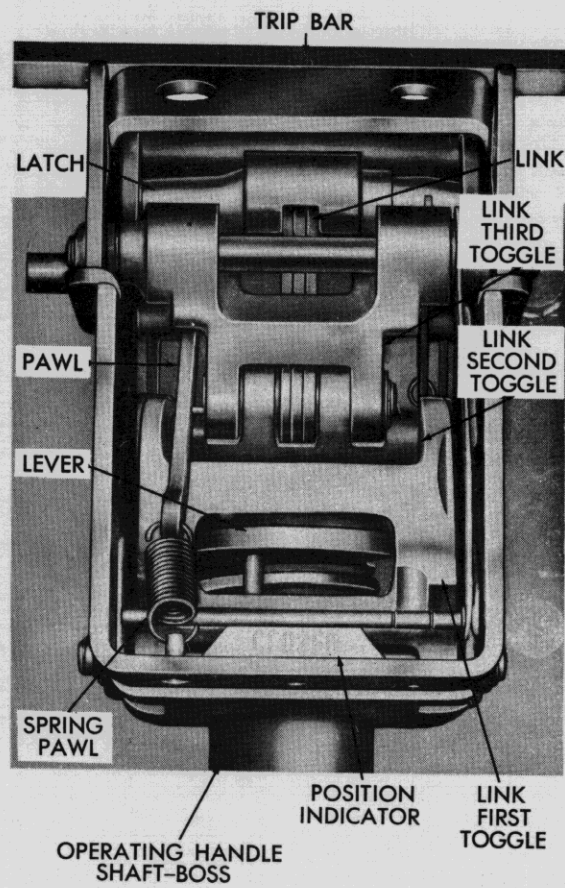
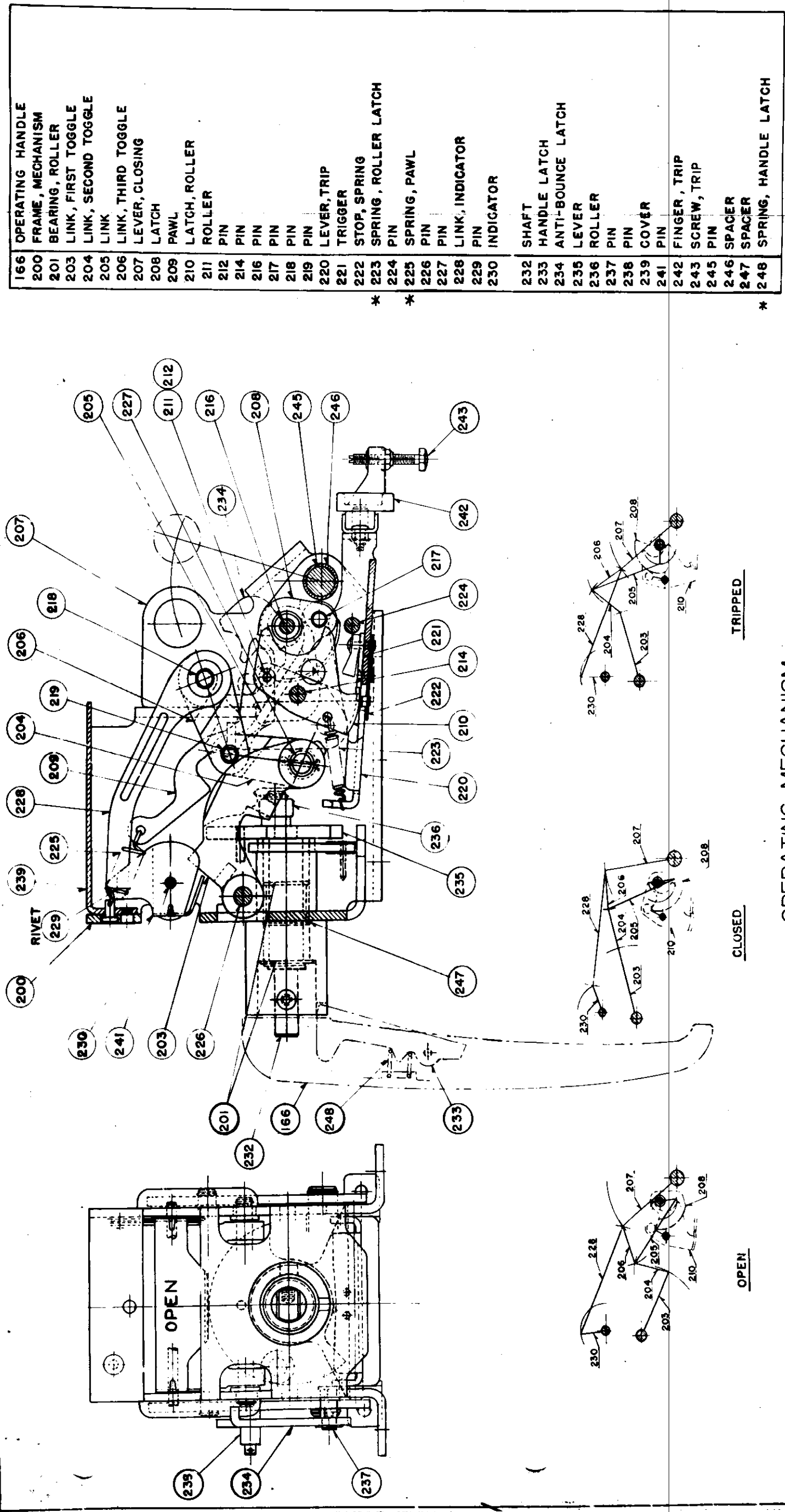

Fig. 5 - Top View of Operating Mechanism



166	OPERATING HANDLE
200	FRAME, MECHANISM
201	BEARING, ROLLER
203	LINK, FIRST TOGGLE
204	LINK, SECOND TOGGLE
205	LINK
206	LINK, THIRD TOGGLE
207	LEVER, CLOSING
208	LATCH
209	PAWL
210	LATCH, ROLLER
211	ROLLER
212	PIN
214	PIN
216	PIN
217	PIN
218	PIN
219	PIN
220	LEVER, TRIP
221	TRIGGER
222	STOP, SPRING
223	SPRING, ROLLER LATCH
224	PIN
225	SPRING, PAWL
226	PIN
227	PIN
228	LINK, INDICATOR
229	PIN
230	INDICATOR
232	SHAFT
233	HANDLE LATCH
234	ANTI-BOUNCE LATCH
235	LEVER
236	ROLLER
237	PIN
238	PIN
239	COVER
241	PIN
242	FINGER, TRIP
243	SCREW, TRIP
245	PIN
246	SPACER
247	SPACER
248	SPRING, HANDLE LATCH

*REPAIR PARTS

OPERATING MECHANISM

- 152. PLATFORM
- 200. MECHANISM
- 340. CLOSING MAGNET YOKE
- 341. STATIONARY CORE
- 342. MOVING CORE
- 343. OPERATING ROD
- 344. PIN
- 345. STOP PLATE
- 346. COIL
- 347. ARM
- 348. BOLT
- 349. BOLT
- 350. BOLT
- 351. BOLT
- 352. BOLT
- 353. ADJUSTING SCREW
- 354. BRACKET, CONTACTOR KICKER
- 355. SPRING
- 356. TRIP ARM
- 357. TRIP ROD
- 358. PIN
- 359. TRIP BRACKET
- 360. CASE OF ANTI-SHOCK--CLOSE DEVICE
- 361. CAM
- 362. WHEEL

- 363. ROLLER
- 364. OSCILLATOR
- 365. PIN
- 366. BRG. WASHER
- 367. TRUARC RING
- 368. PIN
- 369. SPRING, RESET
- 370. PIN
- 371. TRUARC RING
- 372. PIN
- 373. TRUARC RING
- 374. BOLT

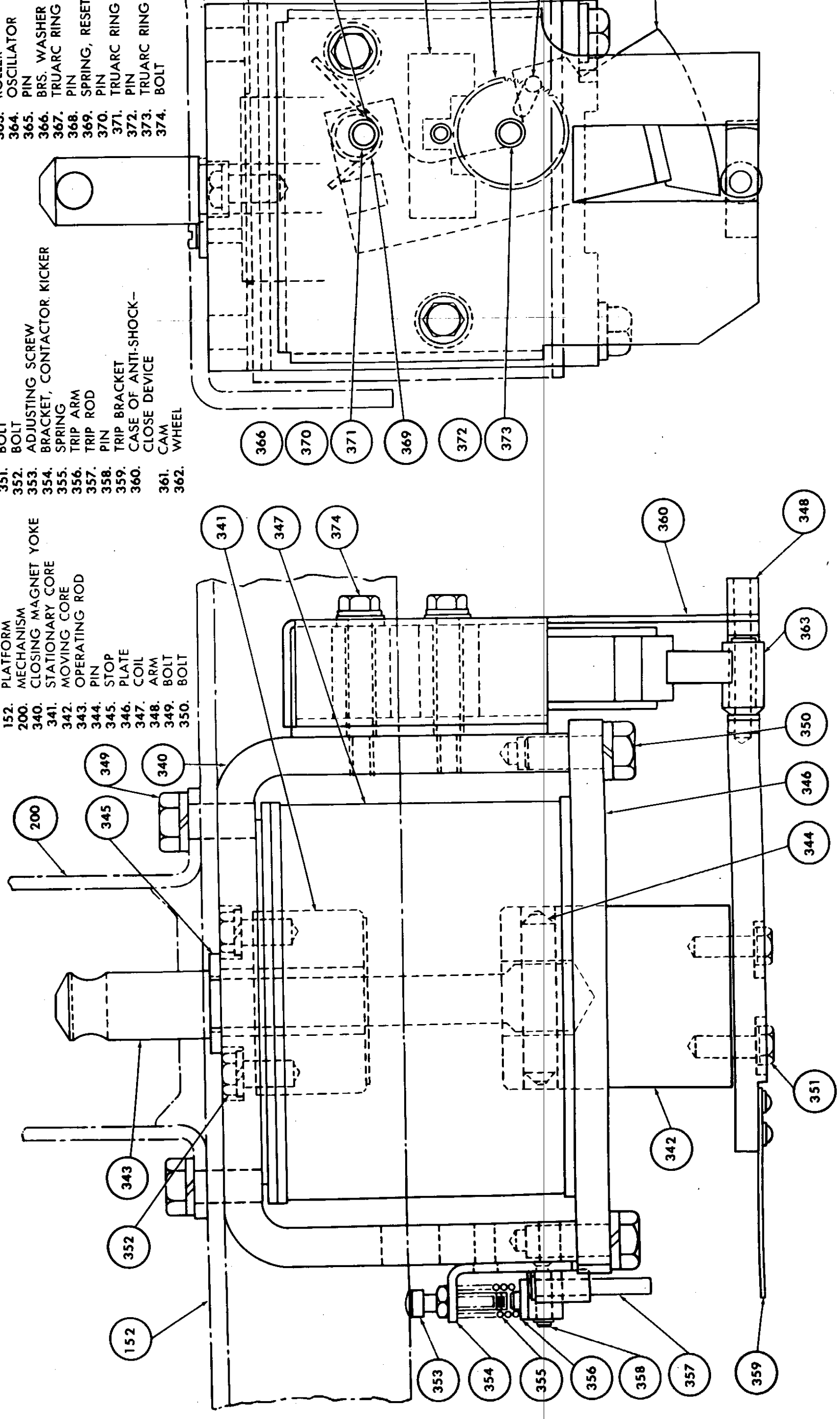

W.C.M. to J.C.



size

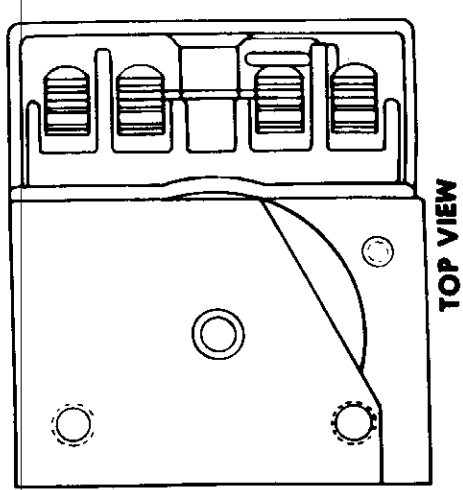
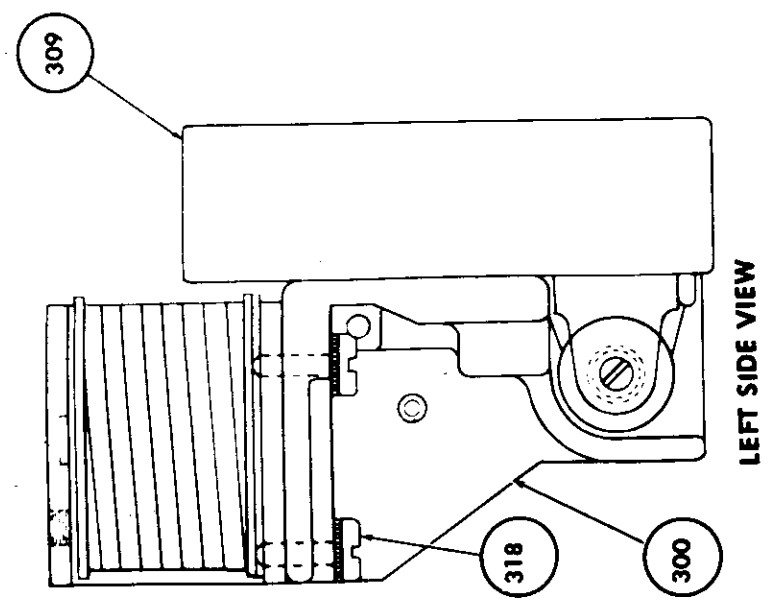
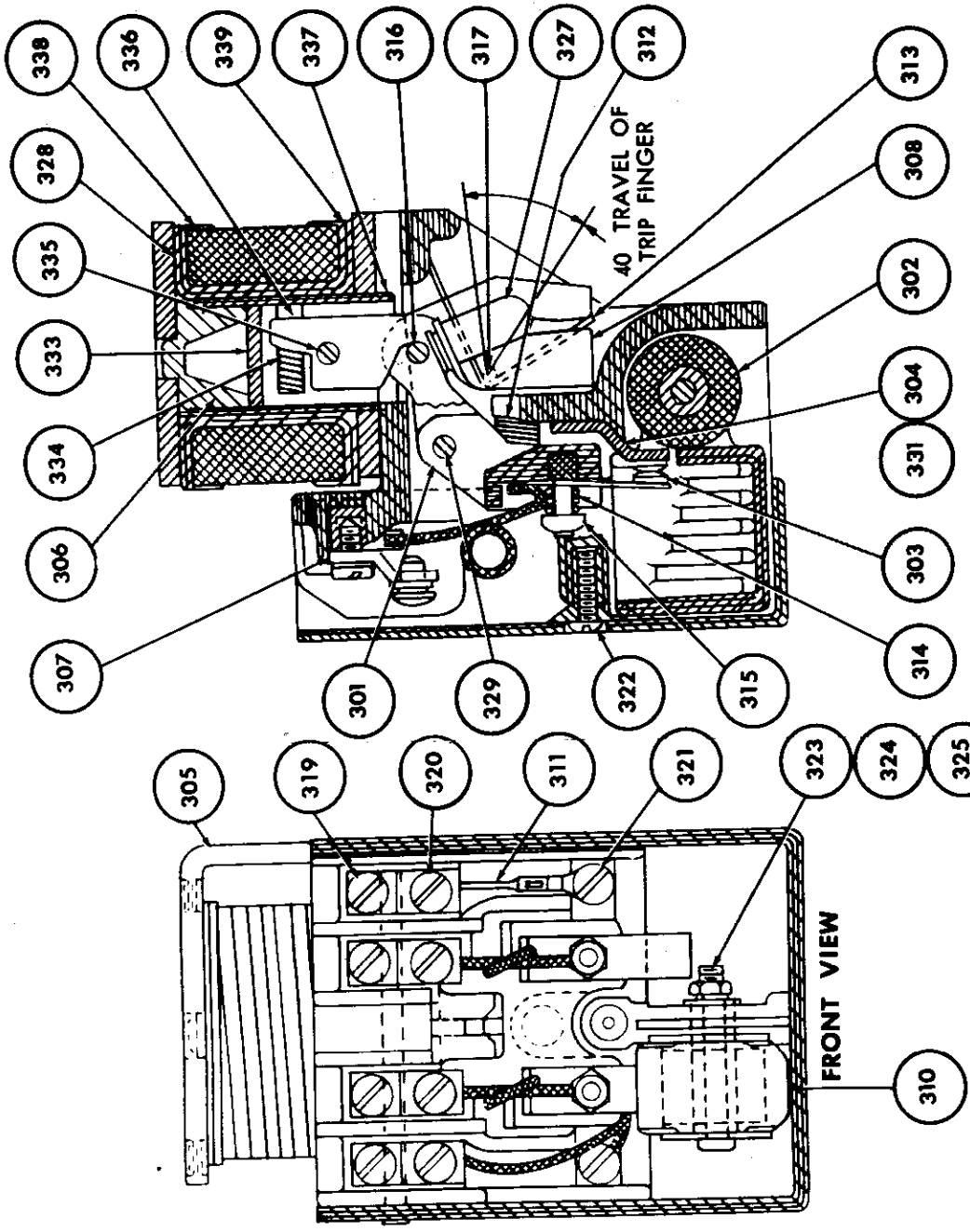

- 300. RELAY BASE
- 301. MOVING CONT. ARM ASSY.
- 302. BLOWOUT MAGNET ASSY.
- 303. MOVING CONT. ASSY.
- 304. STAT. CONT. ASSY. R.H.
- 305. FRAME
- 306. STAT. CORE
- 307. TERMINAL BRACKET
- 308. RELEASE BRACKET
- 309. COVER
- 310. ARC CHAMBER
- 311. TERM. CONN.
- 312. SPRING, CONTACT
- 313. SPRING, TRIP
- 314. SPRING, CONTACT ARM
- 315. ELASTIC STOP NUT
- 316. LATCH PIN
- 317. RELEASE BRKT PIN
- 318. 1/4-20 X 5/8 SCREW
- 319. .190-32 X 3/8 SCREW
- 320. .190 X 1/4 BINDING HD. SCR.
- 321. .164-32 X 3/8 PAN HD. SCR.
- 322. .164-32 X 3/4 PAN HD. SCR.
- 323. .190-32 X 1 3/8 PAN HD. SCR.
- 324. .190 STD. WASHER
- 325. .190 STD. LOCKWASHER
- 326. .190-32 NUT
- 327. FINGER, TRIP
- 328. SPRING WASHER
- 329. CONTACT ARM PIN
- 330. STAT. CONT. ASSY. L.H.
- 331. MOVING CORE
- 332. SPRING, LATCH
- 333. PIN
- 334. LATCH
- 335. LATCH TUBE
- 336. GUIDE TUBE
- 337. OPERATING COIL
- 338. MOLDED SPOOL
- 339.

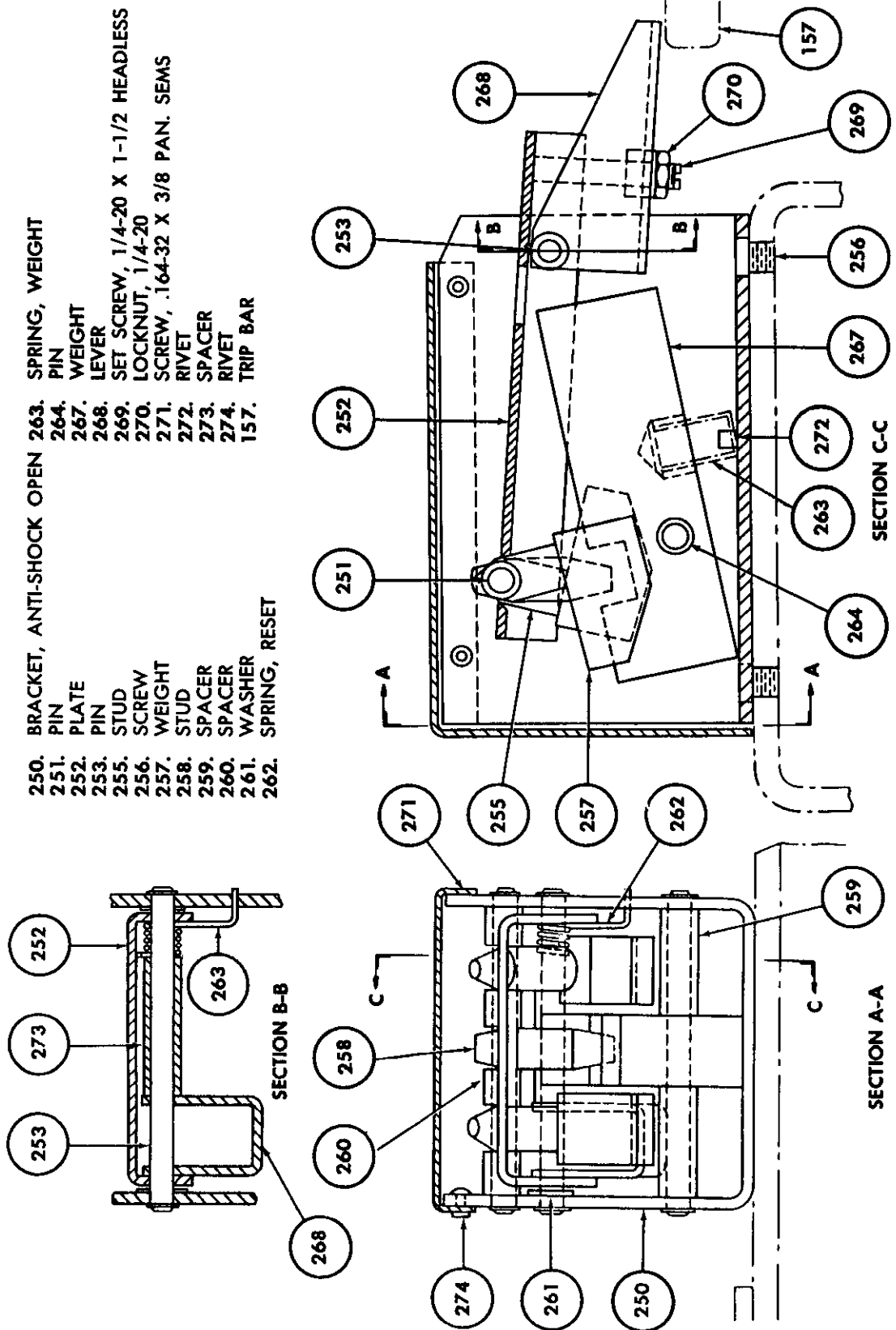
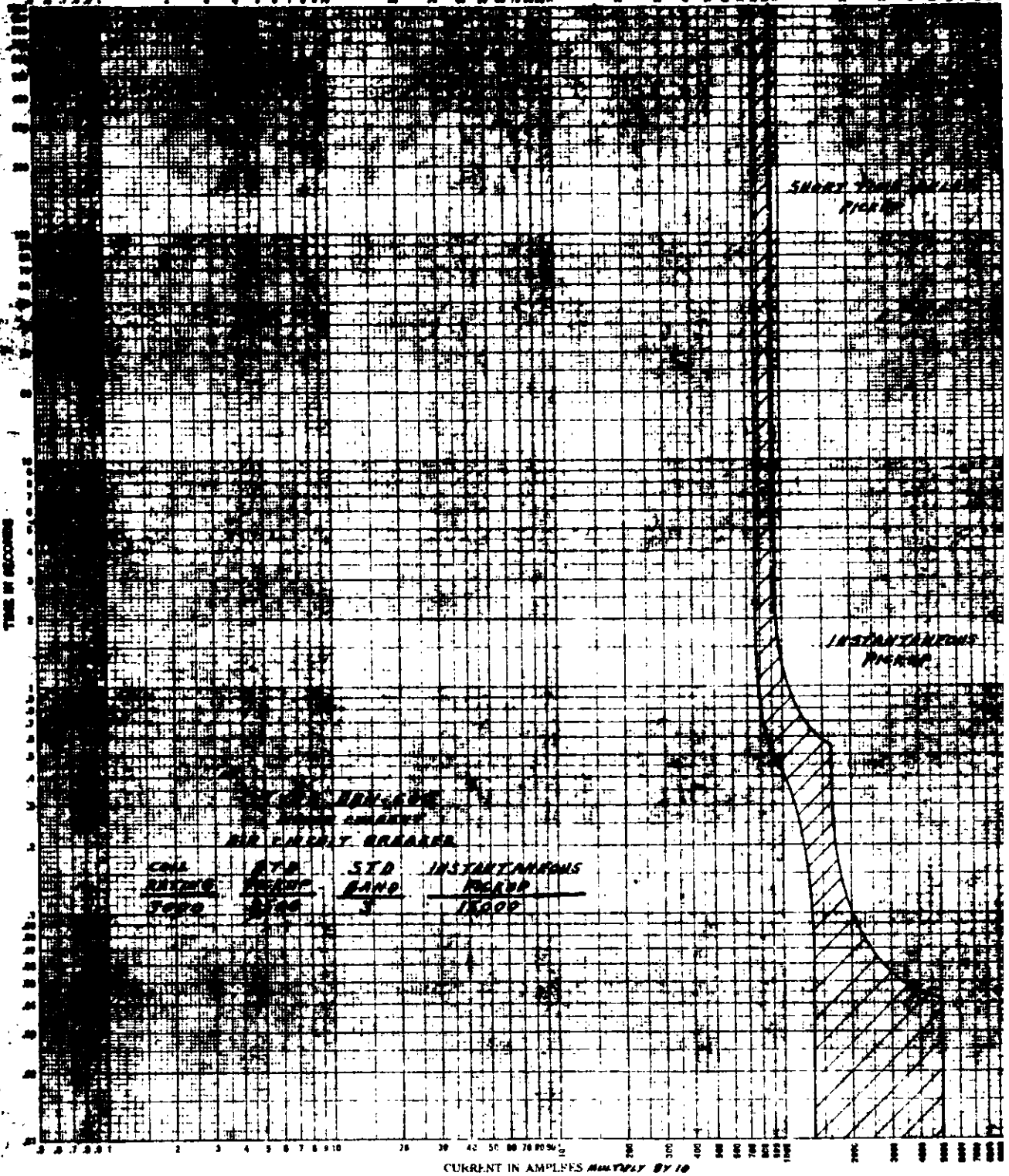

Fig. 9 - Anti-Shock-Open Device



DBN-605 OVERCURRENT TRIP TIME-CURRENT CHARACTERISTIC CURVES

For **S.O. 32-Y-4763 AND 64** Fuse Links In

DATE: **JUNE 25, 1954**

TESTER: **G.A. GILLENWATER**

NO. **388514**

1. Tests made at _____ Volts ac at _____ p.l. Starting at 25C with no initial load

2. Curves are plotted to _____ Test points no variations should be _____

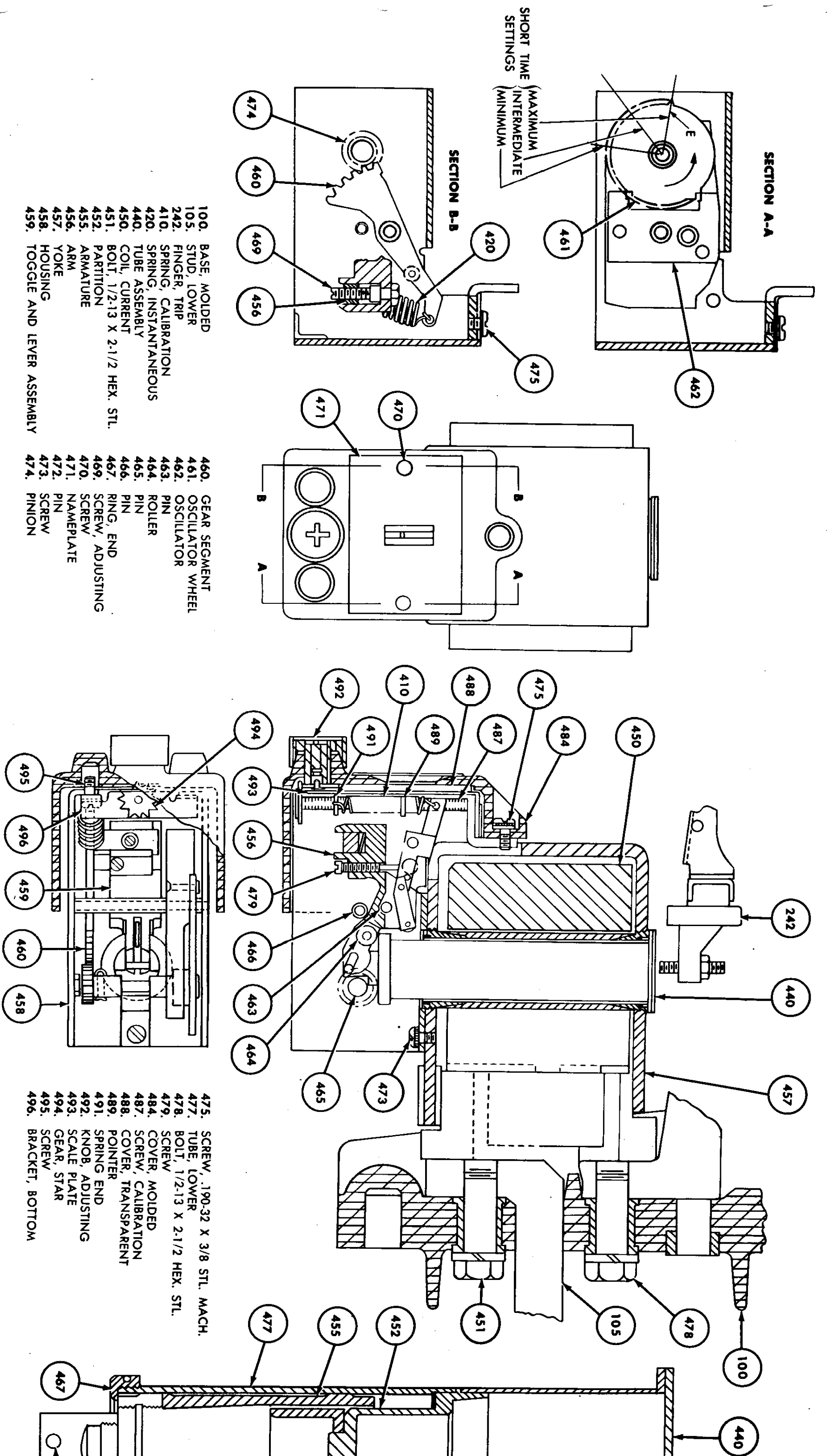

- 100. BASE, MOLDED
- 105. STUD, LOWER
- 242. FINGER, TRIP
- 410. SPRING, CALIBRATION
- 420. SPRING, INSTANTANEOUS
- 440. TUBE ASSEMBLY
- 450. COIL, CURRENT
- 451. BOLT, 1/2-13 X 2-1/2 HEX. STL.
- 452. PARTITION
- 455. ARMATURE
- 456. ARM
- 457. YOKE
- 458. HOUSING
- 459. TOGGLE AND LEVER ASSEMBLY
- 460. GEAR SEGMENT
- 461. OSCILLATOR WHEEL
- 462. OSCILLATOR
- 463. PIN
- 464. ROLLER
- 465. PIN
- 466. PIN
- 467. RING, END
- 469. SCREW, ADJUSTING
- 470. SCREW
- 471. NAMEPLATE
- 472. PIN
- 473. SCREW
- 474. PINION

- 475. SCREW, .190-32 X 3/8 STL. MACH.
- 477. TUBE, LOWER
- 478. BOLT, 1/2-13 X 2-1/2 HEX. STL.
- 479. SCREW
- 484. COVER, MOLDED
- 487. SCREW, CALIBRATION
- 488. COVER, TRANSPARENT
- 489. POINTER
- 491. SPRING END
- 492. KNOB, ADJUSTING
- 493. SCALE PLATE
- 494. GEAR, STAR
- 495. SCREW
- 496. BRACKET, BOTTOM

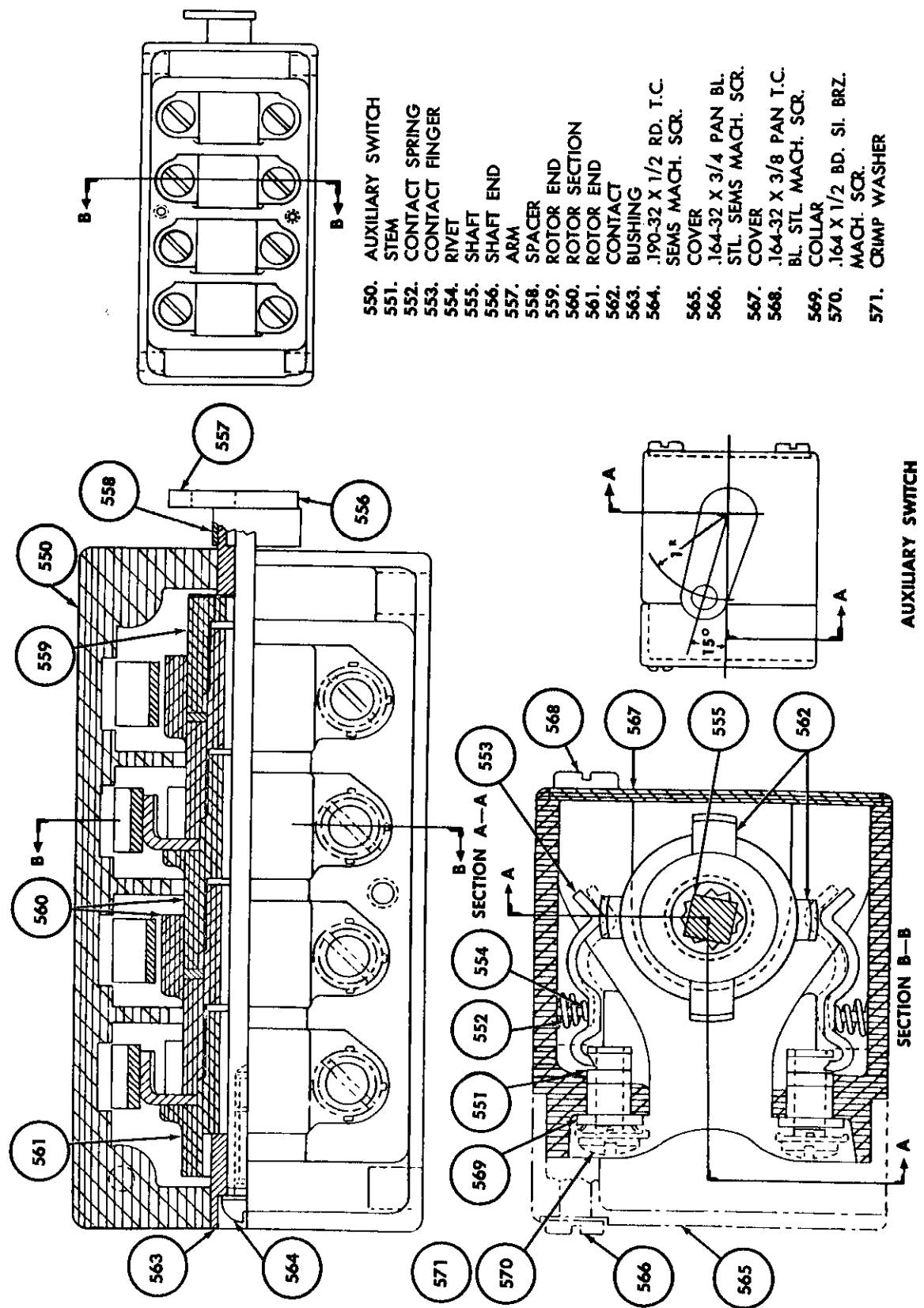

Fig. 12 - Auxilliary Switch

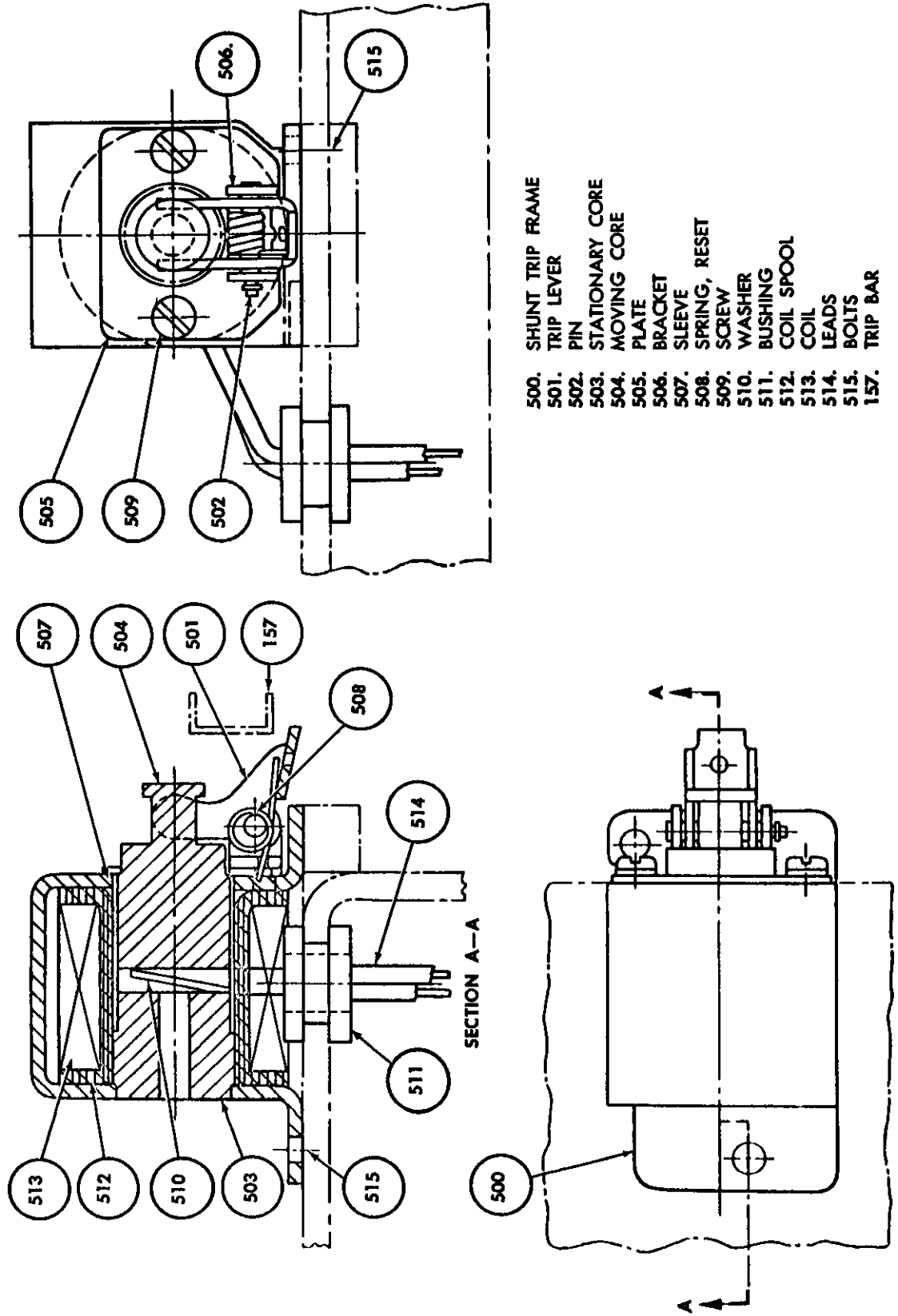

Fig. 13 - Shunt Trip Device

151	PLATFORM		
168	CROSSBAR		
800	FRAME		
* 801	COIL		
802	TUBE		
803	STATIONARY CORE		
804	MOVING CORE		
805	LATCH		
806	SPACER		
* 807	SPRING, TRIGGER RESET		
808	TRIP LEVER		
809	SPACER		
810	BUSHING		
* 811	SPRING, TRIP		
* 812	SPRING, RESET LEVER		
813	SPRING GUIDE		
* REPAIR PARTS			
814	SPRING, ANTI SHOCK		
815	RESET LEVER		
816	PLUNGER		
817	WASHER		
818	NAME PLATE		
819	LATCH PLATE		
820	COVER		
821	BRACKET ASSEM.		
822	WHEEL ASSEM.		
823	TICKER ASSEM.		
824	LEVER		
825	COVER		
826	ROD		
827	RESET LEVER PIN		
828	PAN HEAD SCREW		
829	FLAT HD. SCREW		
830	FIL. HD. SCREW		
831	PIN		

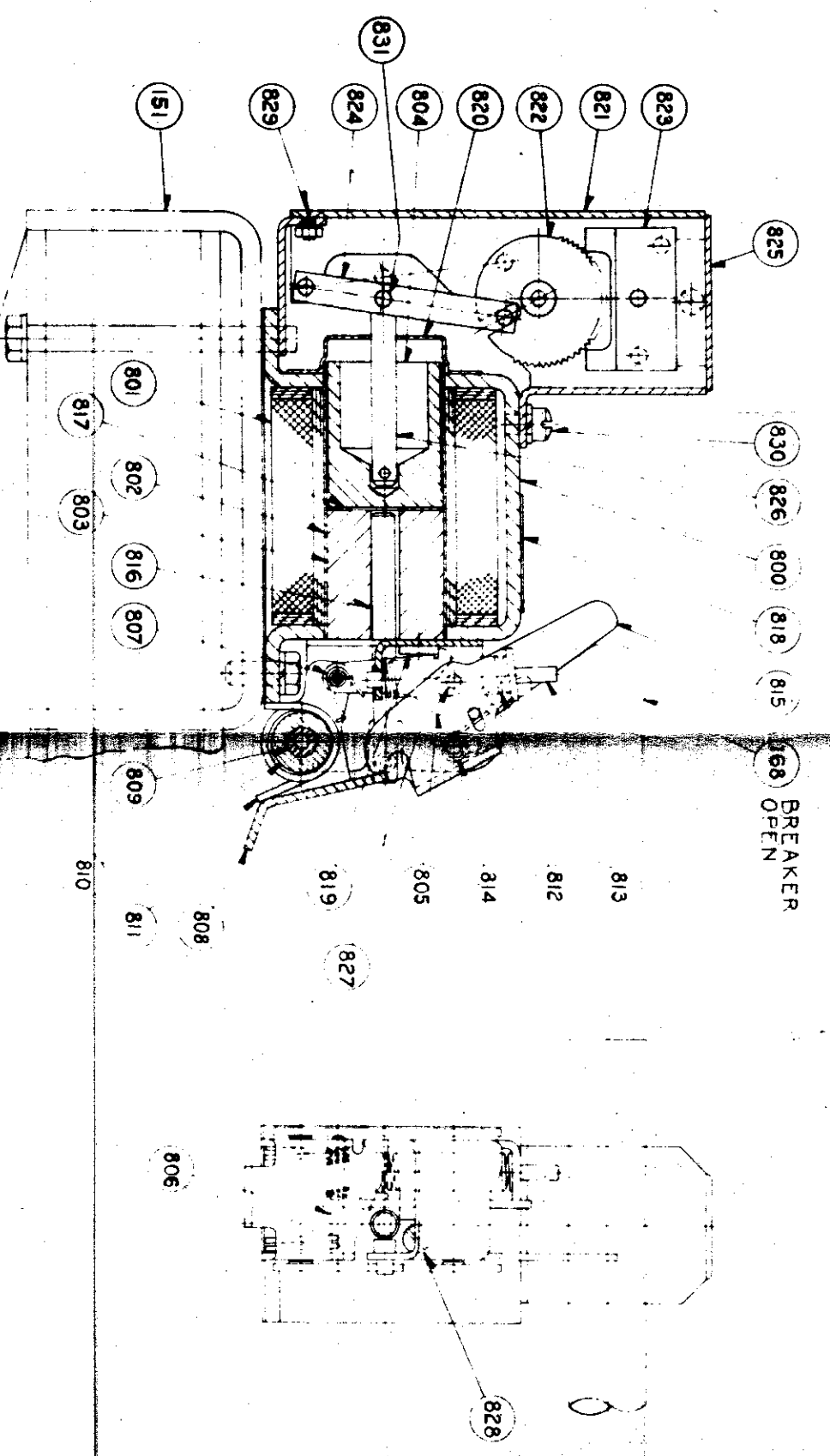

Fig. 19

- REVERSE CURRENT TRIP DEVICE -

**FIG. 2
WITH TIME DELAY**

Fig. 15

100 MOLDED BASE	617 PIN	636 PIN
600 YOKE	618 SPACER	* 637 SPRING, ROD RESET
601 POLE PIECE	619 PIN	638 ADJUSTING SCREW
602 BEARING CASTING	620 PIN	639 LOCKNUT
603 ARMATURE	621 PIN	640 FILTER
604 LUG	622 PIN	641 .190 -32 FIL. HD. MACH. SCREW
605 TRIP LEVER	* 623 COIL, POTENTIAL	642 1/2-13 X 2 1/4 HEX. STL. BOLT
606 LINK	624 COIL, SERIES	643 1/2-13 X 1 1/2 HEX. STL. BOLT
607 BAND	625 TUBE	644 3/8-16 X 1 HEX. STL. BOLT
608 ARM	626 WASHER	645 ADJUSTING SCREW
609 LOCKING PIECE	627 FLAT HD. SCREW	646 CONNECTOR
610 CORE	628 DIAPHRAGM PIN	647 PIN
* 611 5/16-18 X 3 FLAT HD. STL. MACH. SCREW	629 WASHER	* 648 SPRING, DIAPHRAGM RETURN
612 SPRING, CALIBRATION	630 LEVER	
613 CALIBRATION SCREW	631 COVER	
614 1/4-20 SET SCREW	* 632 DIAPHRAGM, SILASTIC RUBBER	
615 BRACKET		
616 SPACER	635 LATCH	

* REPAIR PARTS

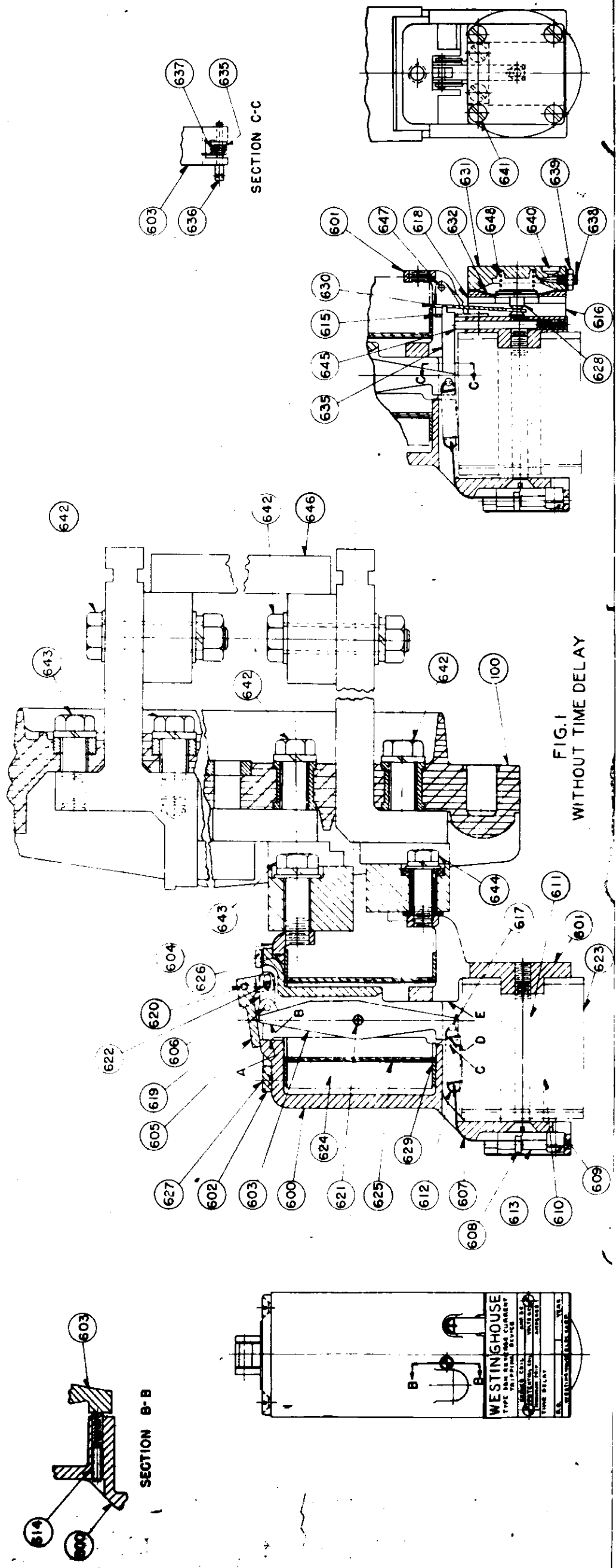
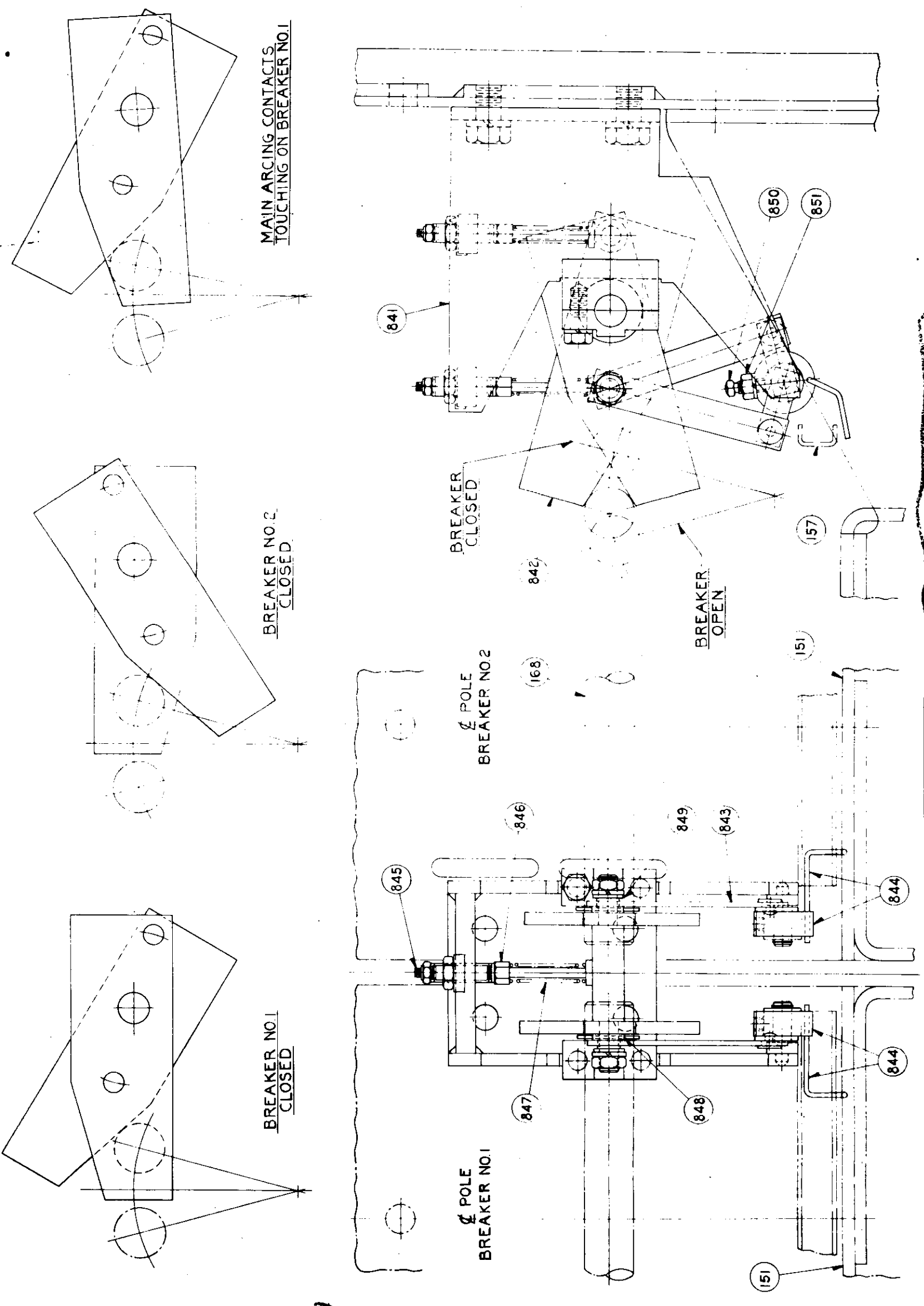

Fig. 16

151	PLATFORM
157	TRIP BAR
168	CROSS BAR
841	BRACKET & BEARING ASSEM.
842	CAM ASSEM.
843	LINK ASSEM.
844	TRIPPER ASSEM.
845	PLUNGER
846	BUSHING
847	SPRING
848	SPACER
849	BUSHING
850	ADJUSTING SCREW
851	LOCK NUT

* REPAIR PARTS

*



REPAIR PARTS LIST O 32-Y-4762
NAVY CONTRACT-NObs-62391 Δ 32-Y-4764
WESTINGHOUSE G.O. WG-70870-L3 S.O.*32-Y-4763

	ITEM NO.	NUMBER OF REPAIR PARTS	NO. INSTALLED PER VESSEL	NAME OF PART	IDENTIFICATION			STANDARD NAVY STOCK NO.
					WESTINGHOUSE			
					STYLE NO.	WT. LB.	DRAWING NO.	
O Δ *	1	9	8	CONTACT - MOVING ARCING	1584472	.8	28A1391	H17WX-12877
O Δ *	2	9	8	CONTACT - STATIONARY ARCING	1584473	.5	22B1721	H17WX-12878
O Δ *	3	4	8	SPRING - ACCELERATION	1584468	.03	18D6383	H17WX-12873
O Δ *	4	2	4	SPRING - ROLLER LATCH	1584519	.01	8D3981	H17WX-12879
O Δ *	5	5	16	SPRING - MAIN CONTACT	1584469	.05	18D6383	H17WX-12874
O Δ *	6	8	32	SPRING - BRIDGE CONTACT	1584470	.08	18D6383	H17WX-12875
O Δ *	7	3	8	SPRING - ARCING CONTACT	1584471	.08	18D6383	H17WX-12876
O Δ *	8	2	4	SPRING - WEIGHT (A.S. OUT)	1584522	.02	9D9236	H17WX-12881
O Δ *	9	2	4	SPRING - RESET (A.S. OUT)	1584521	.02	21D4345	H17WX-12880
O Δ *	10	2	4	SPRING - RESET (A.S. IN)	1611996	.02	23D5209	H17WX-12888
*	11	1	4	SPRING - CALIBRATION (REV. CURR)	1589382	.02	18D9178	H17WX-12858
*	12	2	4	COIL - (REV. CURR) 250 V.D.C.	1581705	1.8	L-484461	
O Δ *	13	2	4	SPRING - HANDLE LATCH	1589485	.02	21D7417	H17WX-12883
O Δ *	14	2	4	SPRING - PAWL	1581956	.03	8D3981	H17WX-12870
O Δ *	15	5	16	SPRING - CALIBRATION (O.C.)	1574796	.02	19D8833	H17WX-12865
Δ *	16	3	8	SPRING - INST. (O.C.)	1611891	.02	19D8833	H17WX-13173
O Δ *	17	3	4	AUXILIARY SWITCH	1581958	.9	18A3835	H17WX-12871
O Δ *	18	3	4	AUXILIARY SWITCH	1767105	.9	25B3146	
O	19	2		COIL - SOLENOID 250 V.D.C.	1802122	16	L-517533	
O Δ *	20	2	4	SPRING - ARM (RELAY)	1574332	.02	17D5806	H17WX-12859
O Δ *	21	2	4	SPRING - LATCH (RELAY)	1491484	.02	17D5806	H17WX-12856
O Δ *	22	2	4	SPRING - TRIP (RELAY)	1533822	.02	18D9176	H17WX-12857
O Δ *	23	6	4	CONTACT - L.H. STATIONARY (RELAY)	1589493	.03	23A3609	H17WX-12885
O Δ *	24	9	4	CONTACT - MOVING (RELAY)	1589495	.03	23A3609	H17WX-12886
O Δ *	25	3	4	SPRING - CONTACT (RELAY)	1491306	.01	17D5806	H17WX-12855
O Δ *	26	2	4	COIL & BKT. BLOWOUT (RELAY)	1589340	.05	13C9668	H17WX-12882
Δ *	27	2	4	COIL (RELAY) 250 V.D.C.	1581778	.66	L-484463	P17WX-1986
O	28	1		SPRING - SHUNT TRIP	1491282	.02	17D1520	H17WX-12854
O	29	1		COIL - SHUNT TRIP 250 V.D.C.	1802140	.6	L-517534	
O	30	2		CONTACT - R.H. STATIONARY (RELAY)	1491296	.03	23A3609	P17WX-1990
Δ *	31	2	4	COIL - (UNDERVOLT.) 250 V.D.C.	1611630		L-484465	P17WX-2492
Δ *	32	2	4	SPRING - (UNDERVOLT.) TRIGGER	1615408	.002	22B7919	P425-16339-9600
Δ *	33	2	4	SPRING - (UNDERVOLT.) TRIP LEVER	1615407	.076	22B7919	P425-16339-9650
Δ *	34	2	4	COIL - SOLENOID 250 V.D.C.	1589481	16	L-500022	P17WX-2106
O	35	2	4	SPRING (REMOTE MAN TRIP)	1809207	.03	18D6383	
Δ *	36	2	4	SPRING (U.V. RESET)	1615406	.02	11D8370	P425-16338-2465
Δ *	37	2	4	SPRING (U.V. OPER. LEVER)	1809109	.01	52P4743	
O	38	1		SPRING - INST. (O.C.)	1736401	.02	19D8833	

BUSHIPS APPRLTR
NObs 62391 (5600)
Ser 560-3449
DATED 23 AUG. 1954

**ACB TYPE DBN-60S
GENERATOR BREAKER**
DWG. 32 B 8055 ^{SUB.} 4

BUSHIPS DWG. NO.	REV.
SS572-56205-1503469	
SHEET 2 OF 3	

WIRING DIAGRAM-FRONT VIEW
NAVY CONTRACT- NObs- 62391
WESTINGHOUSE G.O. WG-70870-L3

S. O. 32-Y-4763

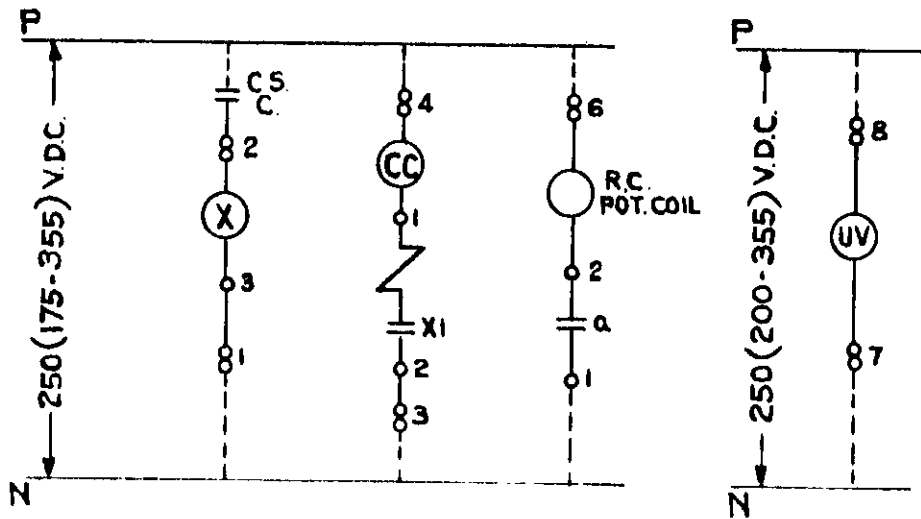
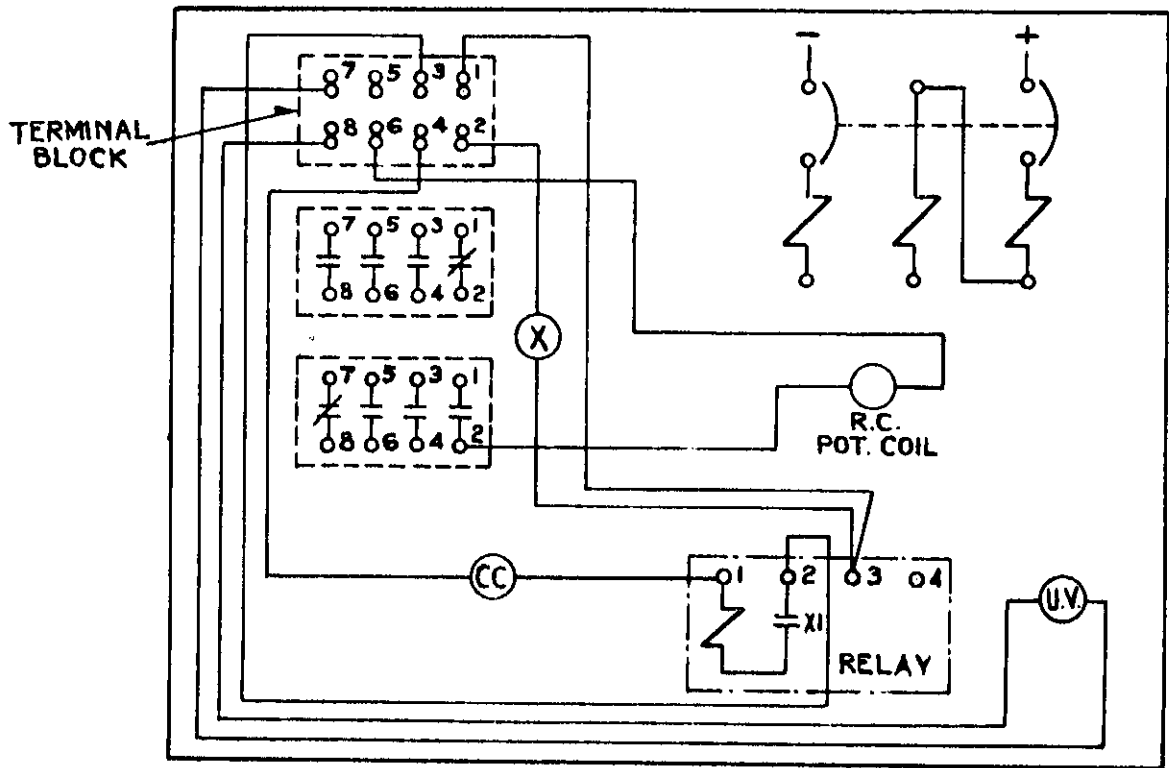

<p>DRAWSMAN THOMSON 6-22-54 CHECKER</p> <p>CERTIFIED <i>Kellenstein</i> 6/24/54</p> <p>BUSHIPS APPROVAL LETTER NObs 62391 (560J) SER 560 9449 DATE 23 AUG. 1954</p>	<p>CERTIFICATION DATA</p> <p>TYPE DBN-60S</p> <p>AIR CIRUIT BREAKER</p> <p>GENERATOR BREAKER</p>	<p>WESTINGHOUSE ELECTRIC CORPORATION EAST PITTSBURGH PA. USA.</p> <p>DWG. 32 B 8055 SUB. 4</p> <table border="1" style="width: 100%; border-collapse: collapse;"> <tr> <td style="width: 80%;">BUSHIPS DWG. NO.</td> <td style="width: 20%;">REV.</td> </tr> <tr> <td>55572-56205-1503469</td> <td></td> </tr> </table> <p style="text-align: center;">SHEET 3 OF 3</p>	BUSHIPS DWG. NO.	REV.	55572-56205-1503469	
BUSHIPS DWG. NO.	REV.					
55572-56205-1503469						

CERTIFICATION DATA FOR CIRCUIT BREAKERS

- A. MASTER DRAWING 56202-3,102,132 REVISION _____
- B. MFR'S DRAWING NO. Δ 1-JH-220 REVISION _____
- C. MASTER DRAWING FIGURES APPLICABLE TO CONTRACT 1
WIRING DIAGRAM SHEET 3
- D. APPLICABLE SPECIFICATION MIL-C-1938 & MIL-C-17409A
AND AMENDMENTS
- E. NAVY CONTRACT OR SHIPBUILDERS' ORDER NO. NObs-62391
- F. MFR'S ORDER NO. GO WG-70870-L3 SO 32-Y-4764
- G. CIRCUIT BREAKER TYPE AND FRAME SIZE-NAVY ACB-1600 FRAME
MFR'S. DBN-60S
- H. DESCRIPTION OF CIRCUIT BREAKER
VOLTAGE 600 MEANS OF CLOSING MANUAL & ELECTRIC
NO. OF POLES 2 NO. OF OVERCURRENT COILS 2
CONNECTIONS REAR MOUNTING DEAD FRONT-STATIONARY
AUXILLIARY SWITCH CIRCUITS 8 (2 N.C. & 6 N.O.) SEE SHEET 3
OVERCURRENT TRIPPING CURVE MFR'S. NO. 388514
- I. COIL RATINGS, PICKUP AND TIME SETTINGS:
1. OVERCURRENT COIL RATING-AMPERES..... 3000
2. LONG-TIME DELAY PICKUP SETTING-AMPERES NONE
3. SHORT TIME DELAY PICKUP SETTING-AMPERES 8500
4. SHORT TIME DELAY BAND SETTING 3
5. INSTANTANEOUS PICKUP SETTING 15,000
6. UNDERVOLT. TRIP RATING-VOLTS 250(200-355) D.C
7. CLOSE COIL RATING — VOLTS 250(175-355) D.C
* 8. CLOSING RELAY COIL RATING-VOLTS..... 250(175-355) D.C
9. REVERSE CURRENT TRIP SETTING- AMPERES... NONE
10. REVERSE CURRENT POTENTIAL COIL — VOLTS... NONE
- J. NUMBER OF SHIPS INVOLVED 2
- K. IDENTIFICATION NUMBERS OF SHIPS SSR-572 & 573
- L. NUMBER OF CIRCUIT BREAKERS PER SHIP 4
- M. TOTAL NO. OF CIRCUIT BREAKERS INVOLVED 8
- N. REPAIR PARTS _____ SHEET NO. 2
- O. ADDITIONAL DATA, REMARKS, NOTES:- _____
HOLD-IN OMITTED.
* CLOSING RELAY COIL HAS INTERMITTENT RATING
Δ BREAKERS MECHANICALLY INTERLOCKED AS PER DWG. 1-JH-3485

DRAFTSMAN DATE <u>THOMSON 6-22-54</u> CHECKER CERTIFIED <u>6/24/54</u> <u>Hellenwath</u> BUSHIPS APPR. <u>LTR NObs 62391</u> <u>(560U) ser. 560</u> <u>9449 OF AUG 23, 1954</u>	CERTIFICATION DATA TYPE <u>DBN-60S</u> AIR CIRCUIT BREAKER GENERATOR BREAKER	WESTINGHOUSE ELECTRIC CORPORATION EAST PITTSBURGH PA. USA DWG. <u>32 B 8056</u> SUB 2 <table border="1" style="width: 100%; border-collapse: collapse;"> <tr> <td style="width: 80%;">BUSHIPS DWG NO.</td> <td style="width: 20%;">REV.</td> </tr> <tr> <td><u>55572-56205-1503470</u></td> <td></td> </tr> </table>	BUSHIPS DWG NO.	REV.	<u>55572-56205-1503470</u>	
BUSHIPS DWG NO.	REV.					
<u>55572-56205-1503470</u>						
SHEET 1 OF 3						

REPAIR PARTS LIST
NAVY CONTRACT - NObS - 62391
WESTINGHOUSE G.O. WG-70870-L3 S.O. 32-Y-4764

ITEM NO.	NUMBER OF REPAIR PARTS NO. INSTALLED PER VESSEL	NAME OF PART	IDENTIFICATION			
			WESTINGHOUSE			STANDARD NAVY STOCK NO.
			STYLE NO.	WT. LB.	DRAWING NO.	
1	8	CONTACT - MOVING ARCING	1584472	.8	28A1391	H17WX-12877
2	8	CONTACT - STATIONARY ARCING	1584473	.5	22B1721	H17WX-12878
3	8	SPRING - ACCELERATION	1584468	.03	18D6383	H17WX-12873
4	4	SPRING - ROLLER LATCH	1584519	.01	8D3981	H17WX-12879
5	16	SPRING - MAIN CONTACT	1584469	.05	18D6383	H17WX-12874
6	32	SPRING - BRIDGE CONTACT	1584470	.08	18D6383	H17WX-12875
7	8	SPRING - ARCING CONTACT	1584471	.08	18D6383	H17WX-12876
8	4	SPRING - WEIGHT (A.S. OUT)	1584522	.02	9D9236	H17WX-12881
9	4	SPRING - RESET (A.S. OUT)	1584521	.02	21D4345	H17WX-12880
10	4	SPRING - RESET (A.S. IN)	1611996	.02	23D5209	H17WX-12888
11	4	SPRING - HANDLE LATCH	1589485	.02	21D7417	H17WX-12883
12	4	SPRING - PAWL	1581956	.03	8D3981	H17WX-12870
13	16	SPRING - CALIBRATION (O.C.)	1574796	.02	19D8833	H17WX-12865
14	8	SPRING - INST. (O.C.)	1611891	.02	19D8833	H17WX-13173
15	4	AUXILIARY SWITCH	1581958	.9	18A3835	H17WX-12871
16	4	AUXILIARY SWITCH	1767105	.9	25B3146	
17	4	COIL (SOLENOID) 250 V.D.C.	1589481	16	L-500022	P17WX-2106
18	4	SPRING - ARM (RELAY)	1574332	.02	17D5806	H17WX-12859
19	4	SPRING - LATCH (RELAY)	1491484	.02	17D5806	H17WX-12856
20	4	SPRING - TRIP (RELAY)	1533822	.02	18D9176	H17WX-12857
21	4	CONTACT - STATIONARY (RELAY)	1589493	.03	23A3609	H17WX-12885
22	4	CONTACT - MOVING (RELAY)	1589495	.03	23A3609	H17WX-12886
23	4	SPRING - CONTACT (RELAY)	1491306	.01	17D5806	H17WX-12855
24	4	COIL & BKT. BLOWOUT (RELAY)	1589340	.05	13C9668	H17WX-12882
25	4	COIL (RELAY) 250 V.D.C.	1581778	.66	L-484463	P17WX-1986
26	4	COIL -(UNDERVOLT.) 250V.D.C.	1611630		L-484465	P17WX-2492
27	4	SPRING -(UNDERVOLT.) TRIGGER	1615408	.002	22B7919	P425-16338-9600
28	4	SPRING -(UNDERVOLT.) TRIP LEVER	1615407	.07	22B7919	P425-16338-9650
29	4	SPRING -(U.V. OPER. LEVER)	1809109	.01	52D4743	
30	4	SPRING (U.V. RESET)	1615406	.02	13D8370	P425-16338-2465

DRAFTSMAN DATE THOMSON 6-22-54 CHECKER CERTIFIED <i>Killerwater 6/24/54</i> BUSHIPS APPR. LTR. NObS 62391 (560U) Ser 560- 9449 OF 400 20, 1954	CERTIFICATION DATA TYPE DBN-60S AIR CIRCUIT BREAKER		WESTINGHOUSE ELECTRIC CORPORATION EAST PITTSBURGH PA. U.S.A.		
	GENERATOR BREAKER		DWG. 32 B 8056 ^{SUB} 2	REV.	
			BUSHIPS DWG. NO.	55 572-5 6235-1503470	
	SHEET 2 OF 3				

WIRING DIAGRAM - FRONT VIEW
NAVY CONTRACT- NObS-62391
WESTINGHOUSE G.O. WG-70870-L3 **S. O. 32-Y-4764**

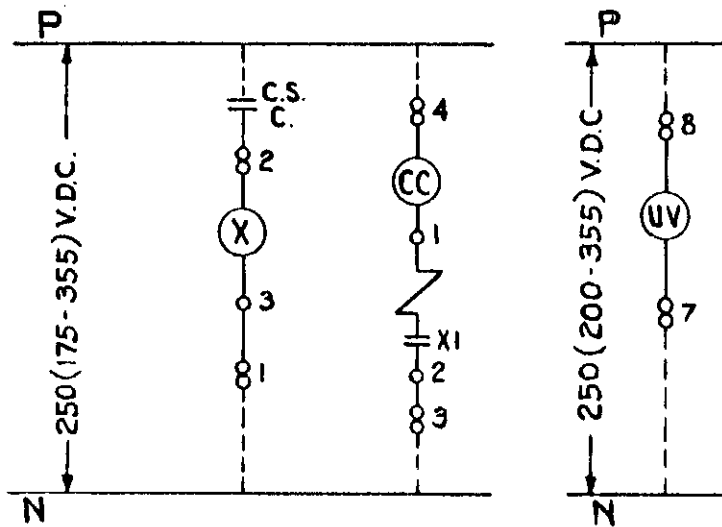
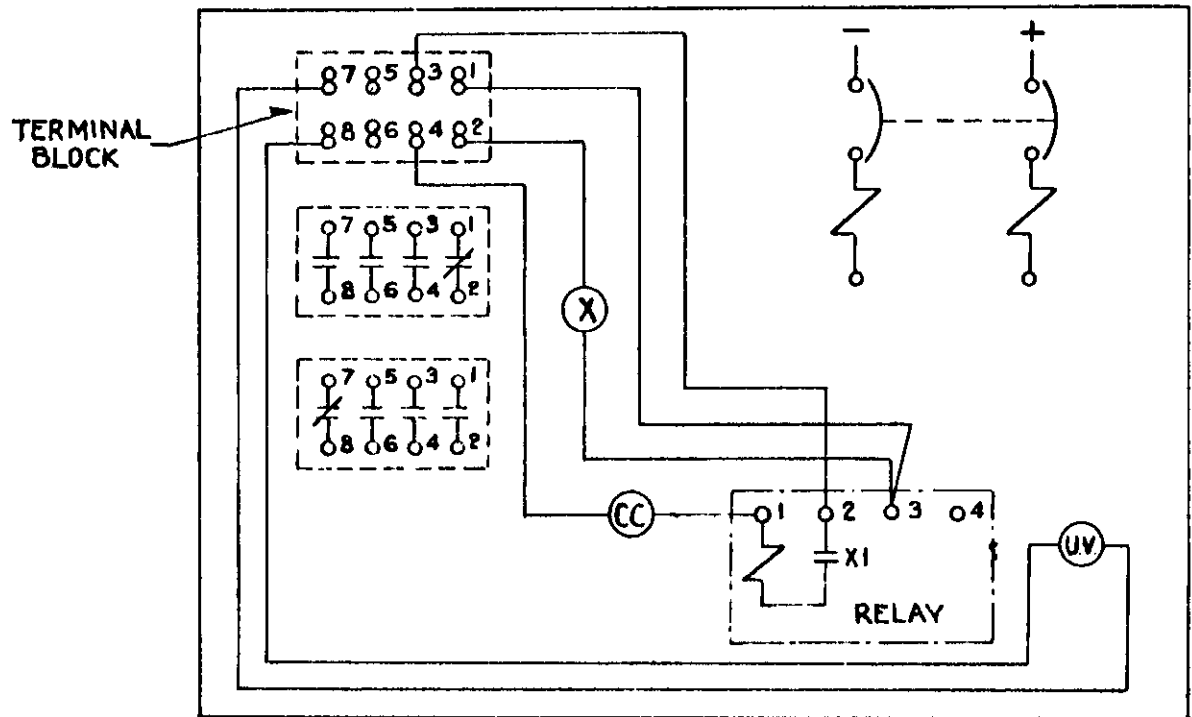

<p>DRAFTSMAN THOMPSON CHECKER 6/22/54</p> <p>CERTIFIED <i>Lillens</i> 6/24/54</p> <p>BUSHIPS APPR. LTR. NObS 62391 (560U) 527.360- 9449 OF AU 23, 1954</p>	<p>CERTIFICATION DATA</p> <p>TYPE DBN-60S</p> <p>AIR CIRCUIT BREAKER</p> <p>GENERATOR BREAKER</p>	<p>WESTINGHOUSE ELECTRIC CORPORATION EAST PITTSBURGH PA. USA.</p> <p>DWG. 32 B 8056 SUB 2</p> <table border="1" style="width: 100%; border-collapse: collapse;"> <tr> <td style="width: 80%;">BUSHIPS DWG. NO.</td> <td style="width: 20%;">REV.</td> </tr> <tr> <td>55572-56205-1503470</td> <td></td> </tr> </table> <p style="text-align: center;">SHEET 3 OF 3</p>	BUSHIPS DWG. NO.	REV.	55572-56205-1503470	
BUSHIPS DWG. NO.	REV.					
55572-56205-1503470						

Free Manuals Download Website

<http://myh66.com>

<http://usermanuals.us>

<http://www.somanuals.com>

<http://www.4manuals.cc>

<http://www.manual-lib.com>

<http://www.404manual.com>

<http://www.luxmanual.com>

<http://aubethermostatmanual.com>

Golf course search by state

<http://golfingnear.com>

Email search by domain

<http://emailbydomain.com>

Auto manuals search

<http://auto.somanuals.com>

TV manuals search

<http://tv.somanuals.com>