

**Instructions for the Selection, Application, and  
Installation of Digitrip RMS Retrofit Kits on  
Westinghouse Types DS and DSL  
Power Circuit Breakers**

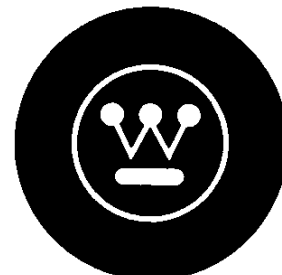

**SEE IMPORTANT DISCLAIMER OF WARRANTIES AND LIMITATION OF LIABILITY IN SECTION 1.**

**Westinghouse Electric Corporation**

Distribution and Control Business Unit  
Five Parkway Center  
Pittsburgh, Pa. 15220

Effective June, 1991

## Table of Contents

Description	Page	Description	Page
Section 1 General Information and Safety Precautions	4	Section 9 Breaker Element Retrofit Kit Installation Procedure	
Section 2 Digitrip RMS Retrofit Kits, Rating Plugs, and Accessories for DS and DSL Breakers		9-1. Breaker Preparation .....	32
2-1. Digitrip RMS Retrofit Kits .....	5	9-2. Amptector Trip Unit Removal .....	32
2-2. Retrofit Kit Installation Requirements .....	5	9-3. Wire Guide Bracket Installation .....	32
2-3. Digitrip RMS Retrofit Kit Accessories .....	5	9-4. Trip Unit Box and Trip Unit Installation .....	32
Section 3 The Digitrip RMS Trip System		9-5. Rating Plug Installation .....	32
3-1. Digitrip RMS Overcurrent Protection .....	9	9-6. Wiring Harness Connection to Breaker "Free b" Contact .....	33
3-2. Current Sensors .....	9	9-7. Potential Transformer Module (PTM) Connection to Breaker .....	33
3-3. Digitrip Trip Unit Box (and Umbilical Wiring Harness with Plug) .....	9	9-8. Direct Trip Actuator (DTA) Installation .....	33
3-4. Digitrip RMS Trip Unit .....	9	9-9. Breaker Trip Shaft Adjustment Procedure .....	34
3-5. Digitrip RMS Direct Trip Actuator (DTA) .....	9	9-10. OTS Switch Adjustment Procedure .....	34
3-6. Digitrip RMS Rating Plug and Battery .....	10	9-11. Current Sensor Connections and Installation .....	34
3-7. Cell Plug, Wiring Harness, and Terminal Block Assembly .....	10	9-12. Positive Power Flow Conventions .....	34
Section 4 Digitrip RMS 500 Basic Retrofit Kits (Without Zone Interlocking)		9-13. Breaker Faceplate Modification .....	35
4-1. Digitrip RMS 500 Basic Retrofit Kit Selection and Content .....	17	Section 10 Switchgear Cell Retrofit Kit Installation	
4-2. Digitrip RMS 500 Basic Retrofit Kit Features .....	17	10-1. Cell Terminal Block Assembly Installation .....	39
Section 5 Digitrip RMS 500 Retrofit Kits (with Zone Interlocking)		10-2. Cell Plug and Wiring Harness Installation .....	39
5-1. Digitrip RMS 500 Retrofit Kit Selection and Content .....	19	10-3. Cell Door Label Installation .....	39
5-2. Digitrip RMS 500 Retrofit Kit Features .....	19	Section 11 Testing, Checkout, and Settings	
Section 6 Digitrip RMS 600 Retrofit Kits		11-1. Dielectric and Meggar Testing .....	40
6-1. Digitrip RMS 600 Retrofit Kit Selection and Content .....	23	11-2. Testing the Digitrip RMS Trip System .....	40
6-2. Digitrip RMS 600 Retrofit Kit Features .....	23	11-3. Digitrip RMS Self-Testing .....	40
Section 7 Digitrip RMS 700 and 800 Retrofit Kits		11-4. Amptector Test Kit .....	40
7-1. Digitrip RMS 700 and 800 Retrofit Kit Selection and Content .....	27	11-5. Primary Injection Testing .....	41
7-2. Digitrip RMS 700 and 800 Retrofit Kit Features .....	27	11-6. Circuit Breaker Checkout and Bench Test .....	41
Section 8 General Preparation for Retrofit		11-7. Setting Digitrip RMS INCOM Address .....	41
8-1. Tools and Accessories Recommended for Installation .....	31	11-8. Identification of Trip Unit, Breaker, and Switchgear Cell .....	41
		Section 12 Operation	
		12-1. Breaker Insertion in Switchgear Cell and Power Up .....	42
		12-2. Information Available to Generator while Breaker is in Service .....	42
		12-3. Information Available in the Event of a Trip .....	42
		12-4. Resetting the Trip Unit After a Trip .....	42
		12-5. Removing the Breaker from the Connect Position .....	42
		Section 13 Digitrip RMS Retrofit Kit Switchgear Assembly Applications	
		13-1. Zone Interlocking .....	44
		13-2. Remote Alarm Signals and the Power Relay Module (ATR) .....	44
		13-3. Communications and INCOM .....	44
		Section 14 Warranty and Service Information	
		14-1. Preventative Maintenance Program .....	51
		14-2. Breaker Maintenance .....	51
		14-3. Warranty Procedure .....	51
		14-4. Digitrip RMS Trip Unit Warranty .....	51
		Section 15 References	~52

## List of Figures

Description	Page	Description	Page
Fig. 2-1 Digitrip RMS Retrofit Kits for DS and DSL Breakers.....	6	Fig. 6-3 Digitrip RMS 600 Retrofit Kit Breaker Interface Diagram.....	25
Fig. 2-2 Digitrip Rating Plugs (50 and 60 Hertz) and their Coordination with DS and DSL Breaker Sensors.....	7	Fig. 6-4 Digitrip RMS 600 Retrofit Kit Switchgear Cell Interface Diagram.....	26
Fig. 2-3 DS Breaker Auxiliary Switches.....	8	Fig. 7-1 DS and DSL RMS 700 Retrofit Kits.....	27
Fig. 2-4 Digitrip RMS Retrofit Kit Accessories.....	8	Fig. 7-2 DS and DSL RMS 800 Retrofit Kits.....	27
Fig. 3-1 DS-416 E.O. Breaker Equipped with Digitrip RMS 800 Retrofit Kit (Front View, Front Cover Removed).....	10	Fig. 7-3 Digitrip RMS 700 and 800 Retrofit Kit Bill of Material.....	28
Fig. 3-2 DS-416 E.O. Breaker Equipped with Digitrip RMS 800 Retrofit Kit (Rear View, Primary Disconnecting Contacts Removed).....	10	Fig. 7-4 Digitrip RMS 700 and 800 Retrofit Kit Breaker Interface Diagram.....	29
Fig. 3-3 Simplified Digitrip RMS Trip System.....	11	Fig. 7-5 Digitrip RMS 700 and 800 Retrofit Kit Switchgear Cell Interface Diagram.....	30
Fig. 3-4 Digitrip Trip Unit Box.....	12	Fig. 9-1 DS Breaker Retrofit Kit Installation.....	35
Fig. 3-5 Digitrip RMS Trip Unit Models.....	12	Fig. 9-2 Trip Unit Box Overcurrent Harness and Sensor Connection Diagrams.....	36
Fig. 3-6 Digitrip RMS Long Time/Instantaneous Time-Current Curve SC4280-87.....	13	Fig. 9-3 Direct Trip Actuator (DTA).....	37
Fig. 3-7 Digitrip RMS Long Time/Short Time Time-Current Curve SC4281-87.....	14	Fig. 9-4 Overcurrent Trip (OTS) Switch Adjustment.....	38
Fig. 3-8 Digitrip RMS Ground Fault Protection Time-Current Curve SC4279-87.....	15	Fig. 9-5 DS Breaker Faceplate Modification.....	37
Fig. 3-9 Digitrip RMS Direct Trip Actuator (DTA).....	16	Fig. 10-1 DS Breaker Connected to Cell Plug, Wiring Harness, and Terminal Block Assembly.....	39
Fig. 3-10 Digitrip RMS Rating Plug and Battery.....	16	Fig. 11-1 DS Breaker Testing with 140D481G03 Amptector Test Kit and Auxiliary Power Module (APM).....	41
Fig. 3-11 Cell Plug, Wiring Harness, and Terminal Block Assembly.....	16	Fig. 13-1 Typical Ground Fault Zone Interlocking Connections for Radial Distribution Systems.....	45
Fig. 4-1 DS and DSL RMS 500 Basic Retrofit Kits (Without Zone Interlocking).....	17	Fig. 13-2 Typical Short Delay Zone Interlocking Connections for Radial Distribution Systems.....	46
Fig. 4-2 Digitrip RMS 500 Basic Retrofit Kit (Without Zone Interlocking) Bill of Material.....	17	Fig. 13-3 Typical Remote ATR Alarm Connections for use with Digitrip RMS 600, 700, and 800 Retrofit Kits.....	47
Fig. 4-3 Digitrip RMS 500 Basic Retrofit Kit Breaker Interface Diagram (Without Zone Interlocking).....	18	Fig. 13-4 Typical INCOM Network Interconnections With Master Computer for use with Digitrip RMS 700, and 800 Retrofit Kits... ..	48
Fig. 5-1 DS and DSL RMS 500 Retrofit Kits (With Zone Interlocking).....	19	Fig. 13-5 Typical INCOM Network Interconnections with Assemblies Electronic Monitor.....	49
Fig. 5-2 Digitrip RMS 500 Retrofit Kits (With Zone Interlocking) Bill of Material.....	20	Fig. 13-6 Typical INCOM Network Interconnections with Remote Computer and Assemblies Electronic Monitor.....	49
Fig. 5-3 Digitrip RMS 500 Retrofit Kit Breaker Interface Diagram (With Zone Interlocking).....	21	Fig. 13-7(A) Typical Control Schematic without CC1/CC2 Modification.....	50
Fig. 5-4 Digitrip RMS 500 Retrofit Kit Switchgear Cell Interface Diagram (With Zone Interlocking).....	22	Fig. 13-7(B) CC1/CC2 Modification to C Typical Control Schematic (Stored Energy).....	50
Fig. 6-1 DS and DSL RMS 600 Retrofit Kits.....	23		
Fig. 6-2 Digitrip RMS 600 Retrofit Kit Bill of Material.....	24		

## Section 1

### General Information and Safety Precautions

#### 1-1. Safety Precautions

The warnings included as part of the procedural steps in this manual are for personnel safety and protection of equipment from damage. An example of a typical warning is shown below to familiarize personnel with the style of presentation. In addition, the following warning applies throughout this manual. It should be read and understood before proceeding.

#### **WARNING**

DS and DSL Circuit Breakers are equipped with high speed, high energy operating mechanisms. The built-in interlocks and safety features are intended to provide safe and proper operating sequences. To provide maximum protection for personnel associated with the installation, operation and maintenance of these breakers, the following practices must be followed:

1. Only qualified persons, as defined in the National Electrical Code, who are familiar with the installation and maintenance of power circuit breakers and switchgear should perform any work associated with these breakers.
2. Completely read and understand these instructions before attempting any installation, operation, maintenance or modification of these breakers.
3. Always turn off and lock out the power source feeding the breaker prior to performing any installation, maintenance or modification of a breaker. Failure to do so could result in electrical shock, leading to death, personal injury or property damage.
4. Do not perform any maintenance, including breaker charging, closing, tripping or any other function which could cause significant movement of the breaker, while it is on the extension rails. Doing so may cause the breaker to slip from the rails and fall, with the potential to cause severe personal injury to those in the vicinity.
5. Do not work on a closed breaker or a breaker with the closing springs charged. The breaker may trip open or the charging springs may discharge, causing crushing or cutting injuries.
6. Do not use the breaker by itself as the sole means of isolating a high voltage circuit. Remove the breaker to the disconnected position before working on the wiring or equipment

downstream from the breaker. Follow all the lockout and tagging rules of the National Electrical Code, and all other applicable codes, regulations and work rules.

7. Do not leave the breaker in an intermediate position in the cell. Always leave it in the Connected, Test, Disconnected or Withdrawn position. Failure to do so could lead to improper positioning of the breaker and flashover, causing death, serious personal injury and/or property damage.

8. Do not defeat any safety interlock. Such interlocks are intended to protect personnel and equipment from damage due to flashover and exposed contacts. Defeating an interlock could lead to death, severe personal injury or property damage.

#### 1-2. Introduction

This manual is provided as a guide, for authorized and qualified personnel only, in the selection, application and installation of Digitrip RMS Retrofit Kits on Westinghouse DS and DSL Power Circuit Breakers.

The information, recommendations, descriptions and safety notations in this document are based on Westinghouse's experience and judgment with respect to retrofitting DS and DSL Circuit Breakers. All possible contingencies which may arise during installation, operation or maintenance, and all details and variations of this equipment do not purport to be covered by these instructions. If further information is desired by the purchaser regarding a particular installation, operation or maintenance of this particular equipment, the local Westinghouse Electrical Corporation representative should be contacted.

#### 1-3. Warranty Disclaimer and Liability Limitation

**NO WARRANTIES, EXPRESS OR IMPLIED, INCLUDING WARRANTIES OF FITNESS FOR A PARTICULAR PURPOSE OR MERCHANTABILITY, OR WARRANTIES ARISING FROM COURSE OF DEALING OR USAGE OF TRADE, ARE MADE REGARDING THE INFORMATION, RECOMMENDATIONS AND DESCRIPTIONS CONTAINED HEREIN.** In no event will Westinghouse be responsible to the purchaser or user in contract, in tort (including negligence), strict liability or otherwise for any special, indirect, incidental or consequential damage or loss whatsoever, including but not limited to damage to or loss of use of equipment, plant or power system, cost of capital, loss of power, additional expenses in the use of existing power facilities, or claims against the purchaser or user by its customers resulting from the use of the information, recommendations and descriptions contained herein.

## Section 2

### Digitrip RMS Retrofit Kits, Rating Plugs, and Accessories for DS and DSL Breakers

#### 2-1. Digitrip RMS Retrofit Kits

The available Digitrip RMS Retrofit Kit style numbers for Westinghouse Type DS and DSL Power Circuit Breakers are listed in Fig. 2-1. The Digitrip RMS Retrofit Kit styles are structured according to the Digitrip RMS Trip Unit and the specific overcurrent protective features provided. Each retrofit kit is standardized for application on all ratings of DS and DSL Power Circuit Breakers.

The product line begins with the Digitrip RMS 500 Basic Retrofit Kit, which provides true RMS sensing, basic overcurrent protection, and self-testing features. The overcurrent protection provided is determined by the selected Long Time (L), Short Time (S), Instantaneous (I), and Ground Fault Time (G) Delay trip functions.

The balance of the Digitrip RMS 500, 600, 700, and 800 Retrofit Kits listed add increasing levels of features to the features of the RMS 500 Basic Retrofit Kit and to each other. The features include zone interlocking, digital alphanumeric displays, remote alarm signals, communications, and energy monitoring capability.

Additional information on the features and content of each Digitrip RMS Retrofit Kit style number is provided in the Sections 4 through 7 of this instruction leaflet.

#### 2-2. Retrofit Kit Installation Requirements

Digitrip RMS Retrofit Kits can be applied on all DS and DSL Drawout Power Circuit Breakers, provided the breakers are used on 50 or 60 hertz AC distribution systems. Fixed mounted (non-drawout) breaker applications should be referred to Westinghouse for evaluation.

The design and content of the retrofit kit is based on the following clarifications, which must be addressed by the retrofit kit purchaser, prior to installation:

1. A rating plug is required to complete the installation. A rating plug is not included in the retrofit kit content and must be ordered separately. Fig. 2-2 provides a complete listing of all rating plugs including those for 50 hertz application. Rating plugs are chosen to coordinate with the breaker sensor rating and determine the breaker  $I_N$  (continuous current) rating.

2. We assume that the existing breaker is equipped with an Amptector Trip System. The Digitrip Retrofit Kit uses the exist-

ing breaker current sensors and the Amptector/sensor wiring harness.

**Note:** Breakers without an Amptector Trip System can also be retrofitted. Select and order the required rating plugs and current sensors from Fig. 2-2. Then fabricate an overcurrent wiring harness using #16 AWG stranded switchboard class wire. Standard overcurrent wiring harness schemes are provided in Fig. 9-2.

3. The existing breaker must have current sensors with a rating of 200:5 or higher.

**Note:** Sensors with rating less than 200:5 must be replaced with 200:5 minimum rating sensors. The lowest available rating plug has a 100 ampere  $I_N$  rating, when applied with a 200:5 rating sensor. The minimum breaker Long Delay Pickup would then be adjustable to 50%  $I_N$  or 50 amperes.

4. (For Digitrip RMS 700 and 800 retrofits only) – A dedicated b (normally closed), auxiliary switch contact must be available on the breaker for use in the retrofit installation.

**Note:** If a dedicated b contact is not available on the breaker, an auxiliary switch or an extra auxiliary switch stage can be added in the field. Refer to Fig. 2-3 for the available styles.

5. Digitrip RMS 600, 700, and 800 Retrofit Kits require an external (customer supplied) 120 Vac source to power the information functions and the alphanumeric digital displays, as applicable, of the trip unit.

6. The breaker must be in good electrical and mechanical operating condition. Breakers that are not in good operating condition should be repaired, reconditioned, or refurbished in addition to retrofitted. Refer to Section 14 for general guidelines on breaker preventative maintenance.

#### 2-3. Digitrip RMS Retrofit Kit Accessories

Fig. 2-4 provides a listing of optional accessories that are useful in the installation, maintenance, and operation of your DS Breaker equipped with a Digitrip RMS Retrofit Kit.

**Fig. 2-1  
Digitrip RMS Retrofit Kits  
for All DS and DSL Power Circuit Breakers**

Digitrip RMS Retrofit Kits	Digitrip RMS Retrofit Kits Style*				
	*RMS 500 KIT (BASIC)	*RMS 500 KIT	*RMS 600 KIT	*RMS 700 KIT	*RMS 800 KIT
<b>Functions</b>					
LI	8188A20G01	8188A20G07	8188A21G01	8188A22G01	8188A23G01
LS	8188A20G02	8188A20G08	8188A21G02	8188A22G02	8188A23G02
LSI	8188A20G03	8188A20G09	8188A21G03	8188A22G03	8188A23G03
LIG	8188A20G04	8188A20G10	8188A21G04	8188A22G04	8188A23G04
LSG	8188A20G05	8188A20G11	8188A21G05	8188A22G05	8188A23G05
LSIG	8188A20G06	8188A20G12	8188A21G06	8188A22G06	8188A23G06

**\*Notes:**

1. The Digitrip RMS 500 Basic Kit includes the RMS 500 Trip Unit, Direct Trip Actuator (DTA), and mounting hardware. The other Kit styles shown also include a breaker-to-switchgear umbilical wiring harness plug with a cell terminal block assembly. Customers connect to the terminal block assembly for access to Digitrip RMS zone interlocking, remote signals, and communications, as applicable.
2. Rating plug and current sensors are not included and must be ordered separately as required.
3. Digitrip RMS 500 Basic Kit styles 8188A20G01-G06 are for replacement of Amptector overcurrent trip functions only. If exterior wiring connection to Digitrip RMS 500 zone interlocking is required, select from Digitrip RMS 500 Kit styles 8188A20G07-G12.
4. Digitrip RMS 700 and 800 require access to a free b (normally closed) contact from the breaker auxiliary switch.

Fig. 2-2 Digitrip Rating Plugs (50 and 60 Hertz) and Their Coordination with DS and DSL Breaker Sensors				
Sensor Rating	Breaker Type DS and DSL	Sensor Styles	60 Hertz Rating Plug Catalog Number and I <sub>n</sub> Rating	50 Hertz Rating Plug Catalog Number and I <sub>n</sub> Rating
50:5 100:5 150:5	DS206 DS206-416 DS206-416	436B080G01 151D995G01 151D995G15	*Note 1 *Note 1 *Note 1	*Note 1 *Note 1 *Note 1
200:5	DS206-416	151D995G02	PD6D02A010 100 Amp PD6D02A020 200 Amp	PD5D02A010 100 Amp PD5D02A020 200 Amp
300:5	DS206-416	151D995G03	PD6D03A020 200 Amp PD6D03A025 250 Amp PD6D03A030 300 Amp	PD5D03A020 200 Amp PD5D03A025 250 Amp PD5D03A030 300 Amp
400:5	DS206-416	151D995G04	PD6D04A020 200 Amp PD6D04A025 250 Amp PD6D04A030 300 Amp PD6D04A040 400 Amp	PD5D04A020 200 Amp PD5D04A025 250 Amp PD5D04A030 300 Amp PD5D04A040 400 Amp
600:5	DS206-416	151D995G06	PD6D06A030 300 Amp PD6D06A040 400 Amp PD6D06A060 600 Amp	PD5D06A030 300 Amp PD5D06A040 400 Amp PD5D06A060 600 Amp
800:5	DS206-416	151D995G08	PD6D08A040 400 Amp PD6D08A060 600 Amp PD6D08A080 800 Amp	PD5D08A040 400 Amp PD5D08A060 600 Amp PD5D08A080 800 Amp
1200:5	DS416-420	151D995G12	PD6D12A060 600 Amp PD6D12A080 800 Amp PD6D12A100 1000 Amp PD6D12A120 1200 Amp	PD5D12A060 600 Amp PD5D12A080 800 Amp PD5D12A100 1000 Amp PD5D12A120 1200 Amp
1600:5	DS416-420	151D995G16	PD6D16A080 800 Amp PD6D16A100 1000 Amp PD6D16A120 1200 Amp PD6D16A160 1600 Amp	PD5D16A080 800 Amp PD5D16A100 1000 Amp PD5D16A120 1200 Amp PD5D16A160 1600 Amp
2000:5	DS420	151D995G20	PD6D20A100 1000 Amp PD6D20A120 1200 Amp PD6D20A160 1600 Amp PD6D20A200 2000 Amp	PD5D20A100 1000 Amp PD5D20A120 1200 Amp PD5D20A160 1600 Amp PD5D20A200 2000 Amp
2400:5	DS632	151D995G24	PD6D24A160 1600 Amp PD6D24A200 2000 Amp PD6D24A240 2400 Amp	PD5D24A160 1600 Amp PD5D24A200 2000 Amp PD5D24A240 2400 Amp
3200:5	DS632	151D995G32	PD6D32A160 1600 Amp PD6D32A200 2000 Amp PD6D32A240 2400 Amp PD6D32A320 3200 Amp	PD5D32A160 1600 Amp PD5D32A200 2000 Amp PD5D32A240 2400 Amp PD5D32A320 3200 Amp
4000:5	DS840	151D995G40	PD6D40A200 2000 Amp PD6D40A240 2400 Amp PD6D40A320 3200 Amp PD6D40A400 4000 Amp	PD5D40A200 2000 Amp PD5D40A240 2400 Amp PD5D40A320 3200 Amp PD5D40A400 4000 Amp
*Note: Rating Plugs for sensors with ratings less than 200:5 are not available. Existing DS circuit breakers equipped with current sensor ratings less than 200:5 require sensor replacement with 200:5 minimum ratio sensors.				

**Fig. 2-3  
Breaker Type RC Auxiliary  
Switches and Switch Stages**

Description	Number of Switches	Style Number
Complete Auxiliary Switch	One Stage Switch	697B536G01
Complete Auxiliary Switch	Two Stage Switch	697B536G02
Complete Auxiliary Switch	Three Stage Switch	697B536G03
Auxiliary Switch Stage	Second Stage only	697B536G08
Auxiliary Switch Stage	Third Stage only	697B536G09

**Notes:**

1. These styles applicable to DS and DSL breakers equipped with type RC auxiliary switches only (See Fig. 3-1). DS and DSL breakers manufactured after 1988 may have Electros witch type auxiliary switches (see Fig. 9-1). If the breaker has Electros witch type auxiliary switches, contact Westinghouse for the correct style number to cover switch addition.
2. Complete auxiliary switch styles are for breakers without an existing auxiliary switch. Styles include mounting hardware, switch assembly, and linkage.
3. Auxiliary switch stage styles are for breakers with an existing auxiliary switch. Styles include extra switch stage and mounting hardware.

**Fig. 2-4  
Digitrip RMS Retrofit Kit Accessories**

Accessory Description	Accessory Style or Catalog Number	Function
Auxiliary Power Module (APM)	PRTAAPM 1267C16G01	Powers Digitrip RMS Trip Unit for Testing
Amp tector Test Kit	140D481G02RR or G03	Tests Digitrip RMS Trip Units equipped with test plugs
Primary Disconnect Removal Tool	591C501G01	For easy removal of breaker primary disconnecting contacts
Breaker Levering Handle	436B696G01	For levering breaker in and out of switchgear cell
Lithium Battery 3.0 Volt	Varta Batteries, Inc. Model CR 1/3N 150 Clarabrook Road Elmsford, NY 10523  Duracell Model DL 1/3N South Broadway Tangtown, NY 10591 (914)-591-7000  Union Carbide Corp. Battery Products Div. Model 2L-76BP Eveready 39 Old Ridgebury Road Danbury, CT 06817-0001 (203)-794-7548	Powers Digitrip LED Mode of Trip Indicators (Back-up Power)



## Section 3

### The Digitrip RMS Trip System

#### 3-1. Digitrip RMS Overcurrent Protection

Your Digitrip RMS Retrofit Kit is designed to replace the existing Amptector Trip System employed on the DS or DSL Breaker selected for retrofitting. Figs. 3-1 and 3-2 show a typical DS Breaker equipped with a Digitrip RMS 800 Retrofit Kit. The RMS 800 Retrofit Kit was selected to show the maximum information possible to aid in the description of all model kits.

All Digitrip retrofit kits provide basic overcurrent protection including a selected combination of Long Time (L), Short Time (S), Instantaneous (I), and Ground Fault Time (G) Delay trip functions. A simplified Digitrip RMS Trip System is shown in Fig. 3-3. Five major components comprise the Digitrip RMS Trip System; the Current Sensors, Digitrip Trip Unit Box, Digitrip Trip Unit, Rating Plug, and the Direct Trip Actuator (DTA). These components are interconnected by use of the existing overcurrent wiring harness to provide the Digitrip RMS Trip System.

#### 3-2. Current Sensors

The Digitrip RMS Trip System uses the existing current sensors and overcurrent wiring harness, originally provided with the Amptector Trip System. Fig. 3-2 shows 3 single rating current sensors (one per phase) located at the rear of the breaker, placed over the lower stud assemblies. The sensors pass intelligence to the Digitrip RMS Trip Unit on the primary current level passing through the breaker. All the energy required to power the Digitrip RMS Trip System is produced by the current sensors.

The current sensors are connected to the Digitrip Trip Unit Box terminal strip by the existing overcurrent wiring harness. The current sensor rating, in concert with the rating plug, determines the  $I_n$  (continuous current) rating of the breaker. At rated primary current, the current sensors provide 5 ampere nominal current inputs to the Digitrip Trip Unit Box.

#### 3-3. Digitrip Trip Unit Box (and Umbilical Wiring Harness with Plug)

The Digitrip Trip Unit Box, Fig. 3-4, physically replaces the Amptector Trip Unit on the breaker. The box has a terminal block strip to terminate the inputs from existing overcurrent wiring harness and provide outputs to the Direct Trip Actuator (DTA). A female edge-card type receptacle is provided in the trip unit box to receive the plug-in Digitrip RMS Trip Unit. Three 5:0.1 ratio auxiliary phase current transformers are enclosed, which reduce the 5 amp nominal inputs from the current sensors to the 100 milliampere level required for the Digitrip RMS Trip Unit electronics.

Depending on the Digitrip RMS Retrofit Kit selected, the following items are mounted on or housed within the trip unit box:

1. One 5:0.2 ratio auxiliary ground current transformer is provided when ground fault protection (G) is selected.
2. An umbilical wiring harness with plug is provided on all units except the RMS 500 Basic Kits. The umbilical harness extracts zone interlocking, remote alarm, and INCOM communications signals, as applicable, from the trip unit box. The umbilical harness plugs into a cell plug, wiring harness, and terminal block assembly, mounted in the switchgear cell.

3. Power Relay Module (ATR) is provided on Digitrip RMS 600, 700, and 800 Retrofit Kits. The ATR provides contact closures on High Load (HL), Long Delay Trip (LD), Short Circuit Trip (SC), Ground Fault Trip (GF) functions for remote alarms. The ATR requires a 120 Vac input to power up the Digitrip RMS Trip Unit alphanumeric display and INCOM signals, as applicable. The ATR contacts are rated 1 ampere at 120 Vac or 1 amperes at 28 Vdc.

4. Potential Transformer Module (PTM) with a disconnect plug is provided on Digitrip RMS 700 and 800 Retrofit Kits. The PTM provides secondary voltage inputs to the trip unit from the primary circuit breaker voltage. A disconnect plug is provided to disconnect the PTM from the breaker and protect the trip unit when dielectric testing of the breaker is performed.

#### 3-4. Digitrip RMS Trip Unit

The Digitrip RMS Trip Unit is a microprocessor based protective device that provides true RMS sensing means for proper correlation with thermal characteristics on conductors and equipment. The trip unit is equipped with a male edge-card connector, which plugs into the female edge-card receptacle in the trip unit box. The trip unit has a female type receptacle is to accept the rating plug, which determines the  $I_n$  (continuous current) rating of the breaker.

Digitrip RMS Trip Units are available in four basic models, RMS 500, 600, 700 and 800, as shown in Fig. 3-5. Each trip unit has adjustable current protective settings for the Long Time (L), Short Time (S), Instantaneous (I), and Ground Fault Time (G) Delay trip functions selected. Short Time (S) and Ground Fault (G) Delays are equipped with an adjustable setting for a flat or an  $I^2t$  response. The adjustable settings are step-type, expressed in terms of the  $I_n$  (continuous current) rating of the breaker. LEDs provide mode of trip indications for the L, S, I, and G trip functions. Additional features for each model are detailed in Sections 4 through 7 of this instruction leaflet.

Figs. 3-6 through 3-8 provide the Digitrip RMS Characteristic Curves and the available trip unit settings for all trip functions.

Digitrip RMS Trip Units are equipped with a receptacle to receive the Auxiliary Power Module (APM). The APM is an accessory item used to supply power to the trip unit self-test system.

#### 3-5. Digitrip RMS Direct Trip Actuator (DTA)

Digitrip RMS Retrofit kits include a 700 ohm (nominal impedance) Direct Trip Actuator (DTA), which replaces the existing DTA originally provided with the Amptector Trip System. The DTA, Figs. 3-1, 3-3, and 3-9, receives an electrical trip pulse from the trip unit and provides the mechanical trip force to trip the breaker.

The DTA is made up of a permanent magnet, a disc held by the magnet, a rod acted on by a spring, a trip plunger for tripping the breaker, and a reset lever for mechanically resetting the actuator. The magnet cannot pull and reset the disc against the force of the spring acting on the rod, but it can overcome the spring force when the disc is in contact with the magnet pole piece.

A tripping pulse from the Digitrip RMS Trip Unit counteracts the effect of the permanent magnet, allowing the spring to separate the disc from the magnetic pole piece and to actuate

the trip plunger. The spring fires the trip plunger downward, striking the breaker trip shaft lever, tripping the breaker. As the breaker opens, the left pole unit lever pin strikes the spring finger attached to the reset lever. This action moves the disc to close the air gap between it and the permanent magnet. The DTA is reset when the disc is held in contact against the magnet and against the spring force. If the DTA does not reset properly, the trip plunger will hold the breaker in the trip free condition and the breaker will not be able to close.

### 3-6. Digitrip RMS Rating Plug and Battery

The Digitrip RMS Rating Plug, Fig. 3-10, plugs into the Digitrip RMS Trip Unit to determine the breaker  $I_n$  (continuous current) rating. The rating plug must be matched to the installed current sensor rating and the distribution system frequency, i.e. 50 or 60 hertz. Each rating plug has fixed  $S_1$  and  $S_2$  values, which correspond to the Short Delay trip unit settings and  $M_1$  and  $M_2$  values, which correspond to the Instantaneous trip unit settings.

The rating plug is equipped with a long-life 3.0 Volt lithium type battery. This back-up battery is not used to power the Digitrip RMS overcurrent protective circuit. It maintains the trip unit mode of trip indication LEDs following a breaker tripping operation, when no external 120 Vac control power source is applied. Without the external 120 Vac source applied, a new battery will maintain the mode of trip LED for approximately 60 hours. The battery is replaceable from the front, without having to remove the rating plug from the trip unit. Replacement battery types are listed under the Accessories section of this instruction leaflet.

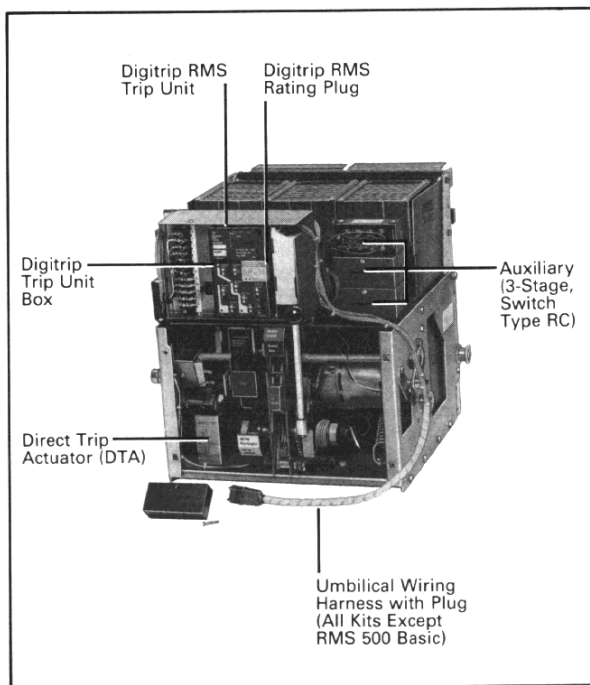

Fig. 3-1. DS-416 E.O. Breaker Equipped with Digitrip RMS 800 Retrofit Kit (Front View, Front Cover Removed)

If a rating plug is removed when the breaker is in the closed position, the breaker may trip. Therefore, the rating plug must remain securely installed in the trip unit until the breaker is in the open position.

### 3-7. Cell Plug, Wiring Harness, and Terminal Block Assembly

The cell plug, wiring harness, and terminal block assembly shown in Fig. 3-11 is provided on all retrofit kits, except the Basic RMS 500. Its function is to extract the zone interlocking, remote alarm, and communications signals from the breaker and provide terminations for external customer connections. Use of the assembly reduces the time required for retrofit. It eliminates the need to completely rewire the secondary contacts on the circuit breaker and in the switchgear to accommodate the added Digitrip RMS signals.

The assembly mounts in the breaker compartment of the switchgear on the right hand side sheet. The cell plug receives the breaker umbilical plug, providing a disconnecting means of extracting the signals from the breaker. A wiring harness brings the signals to terminal blocks for customer external connections in the switchgear. Depending on the retrofit kit selected, up to 3 terminal blocks are provided. Space also exists for the field addition of a fourth terminal block, if required.

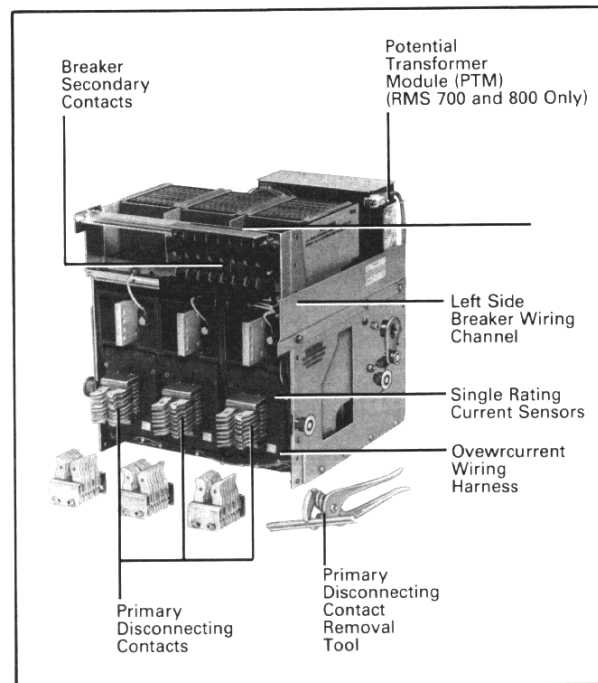

Fig. 3-2. DS-416 E.O. Breaker With Digitrip RMS 800 Retrofit Kit (Rear View, Primary Disconnecting Contact Removed)

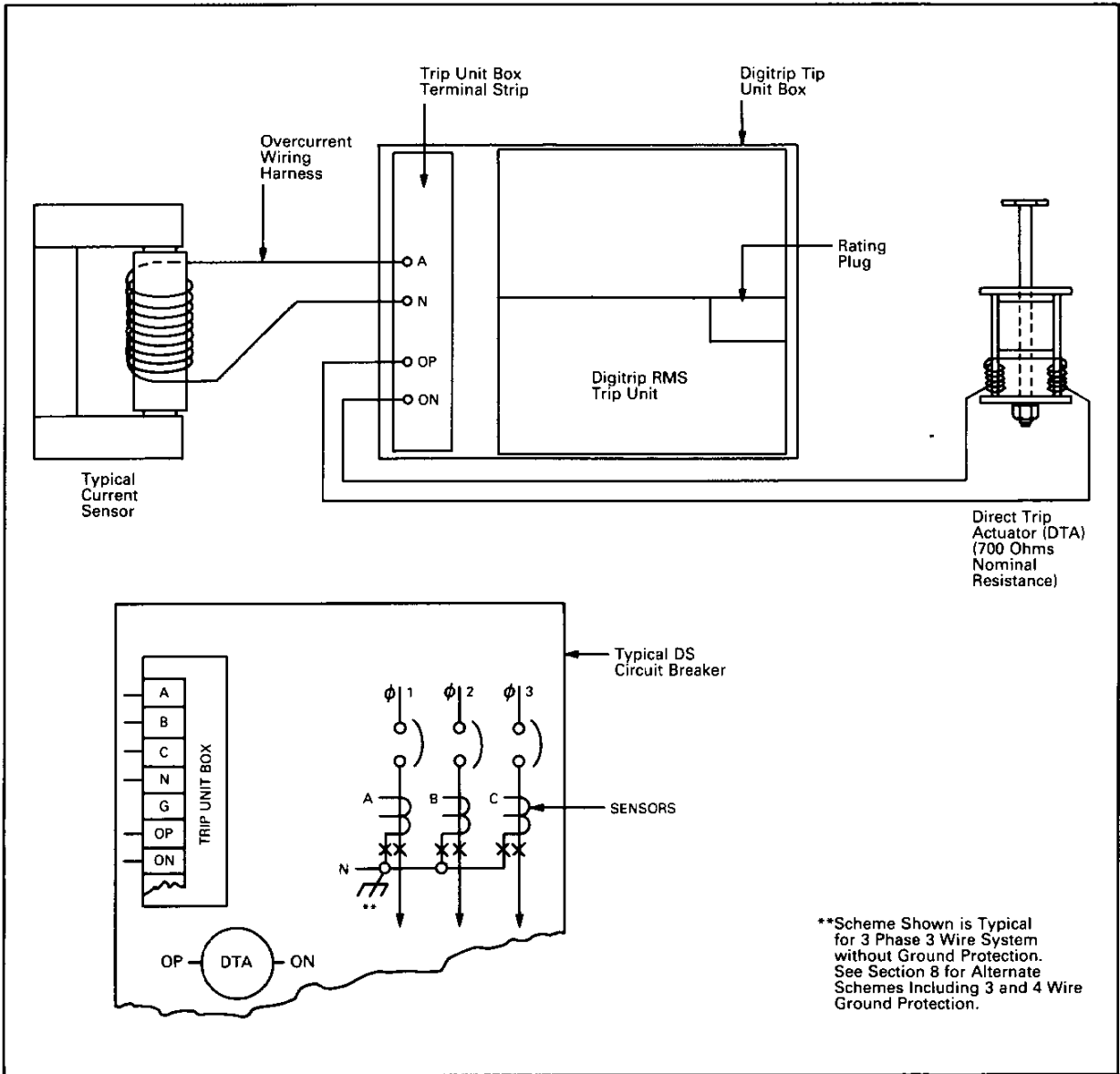

Fig. 3-3. Simplified Digitrip RMS Trip System

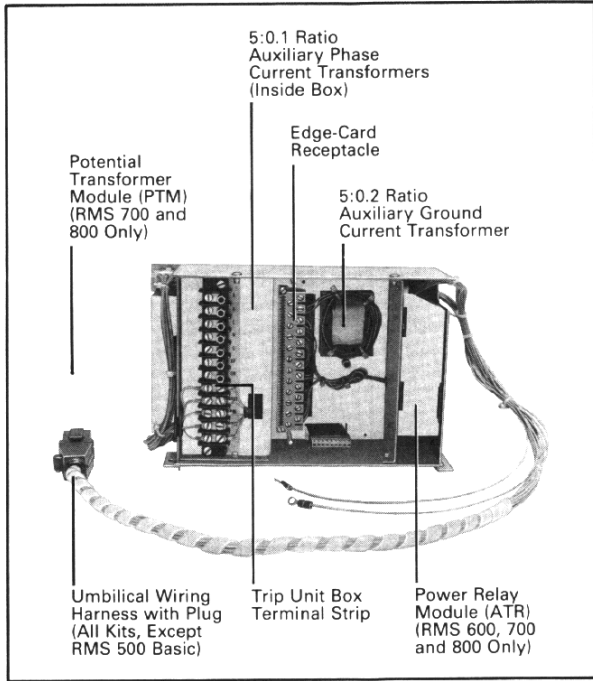

Fig. 3-4. Digitrip Trip Unit Box

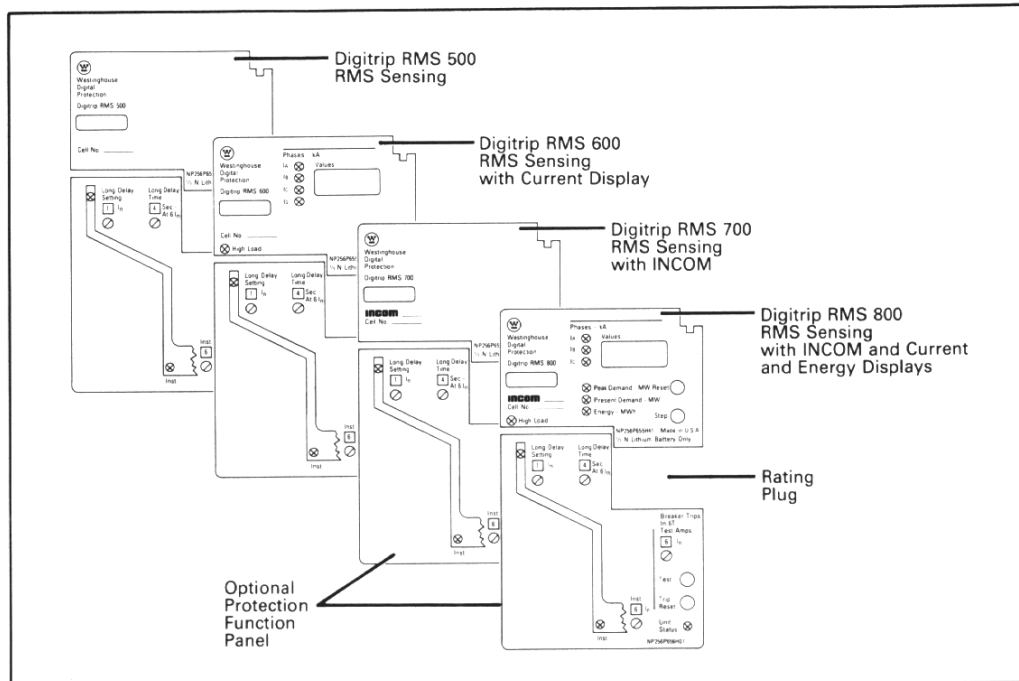

Fig. 3-5. Digitrip RMS Trip Unit Models

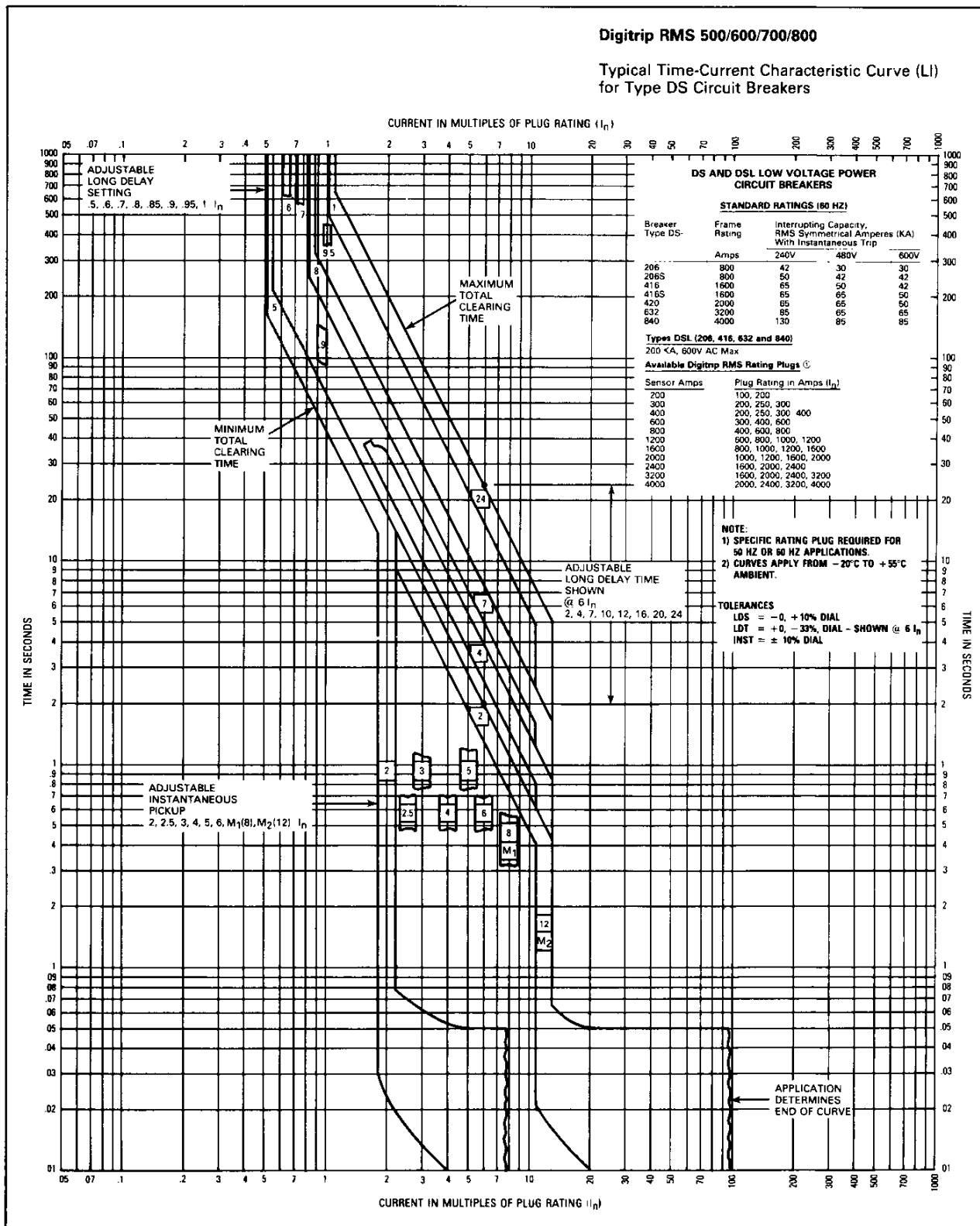

Fig. 3-6. Digitrip RMS/Instantaneous Time-Current Curve SC4280-87

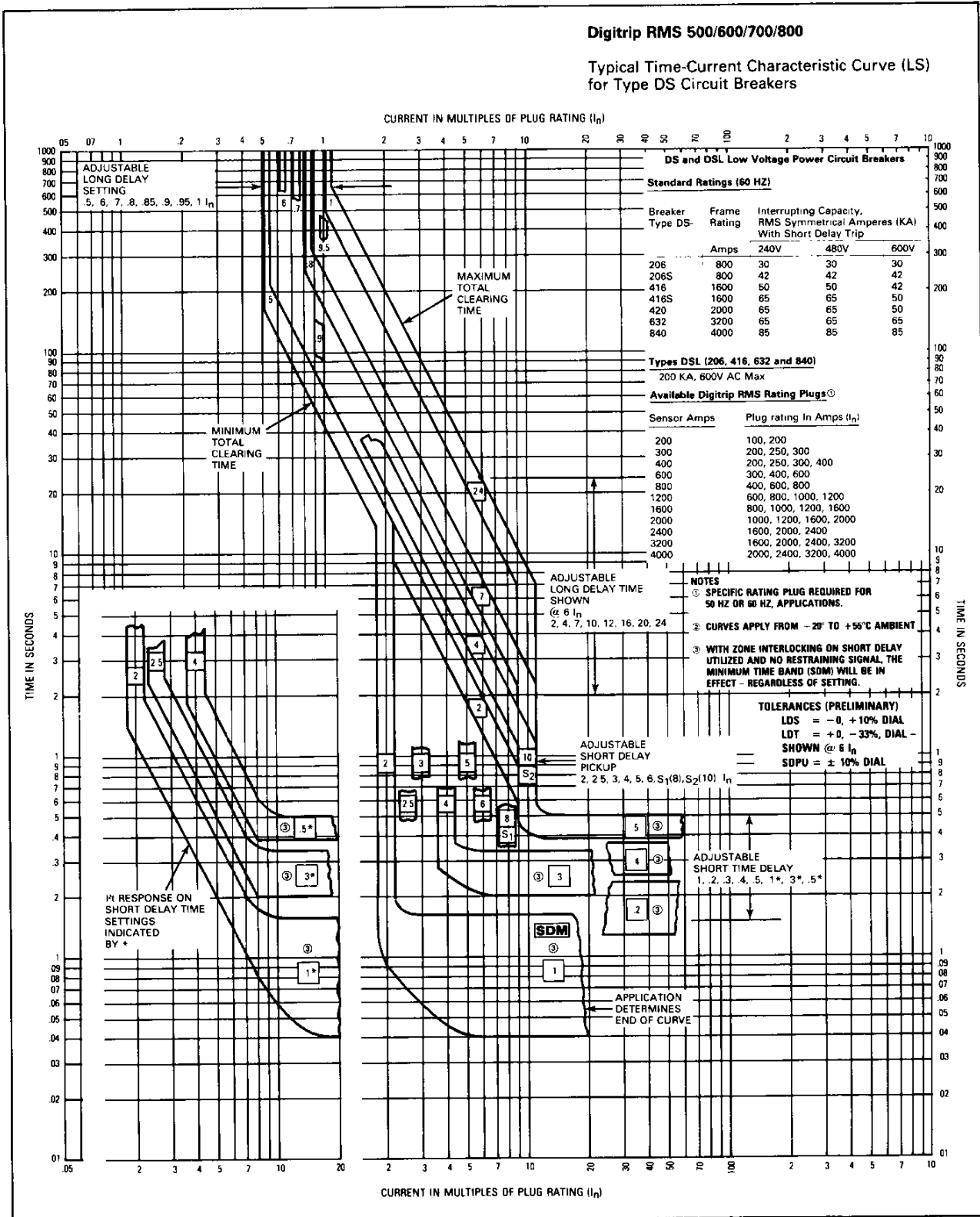

Fig. 3-7. Digitrip RMS Long Time/Short Time Time-Current Curve SC4281-87

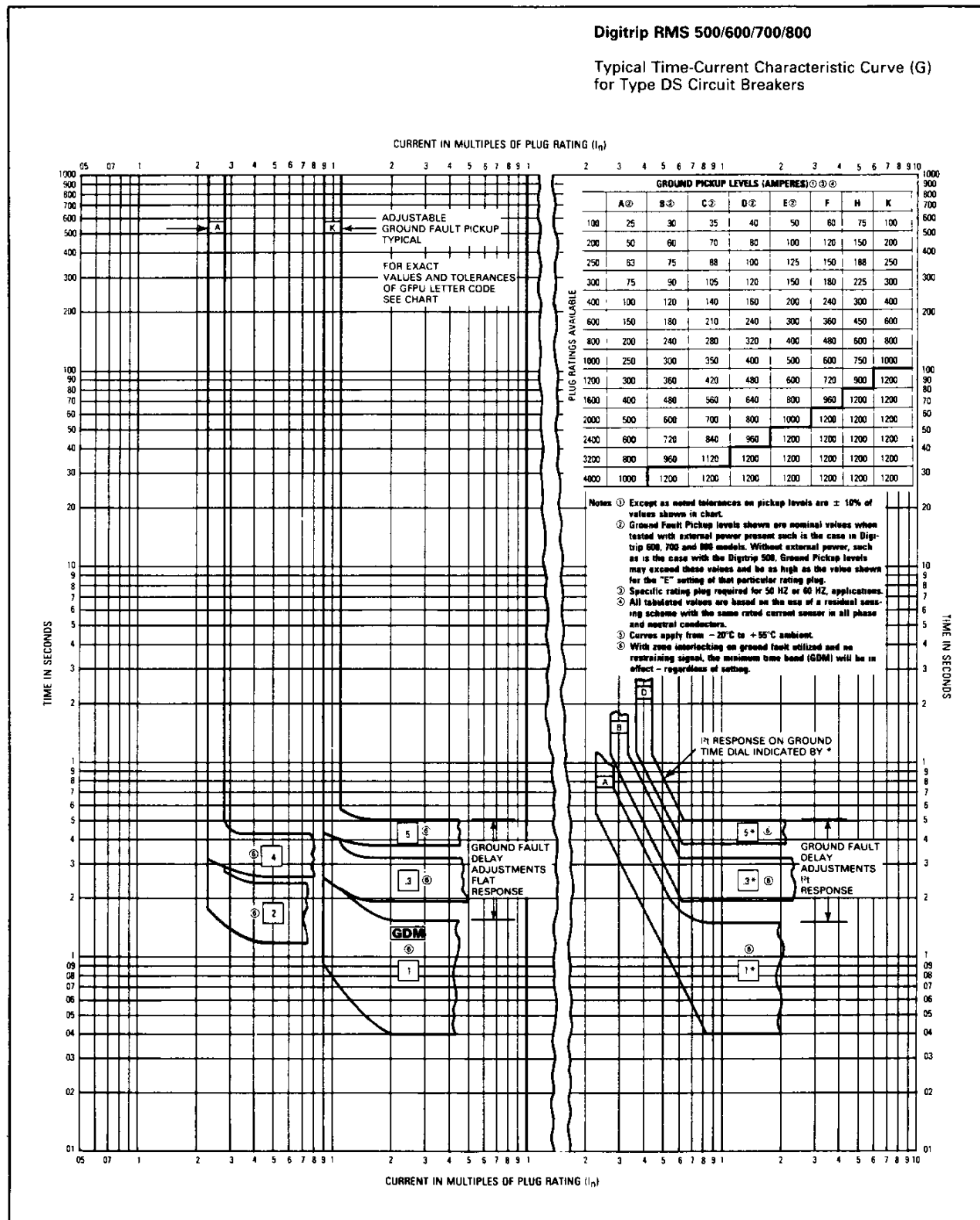

Fig. 3-8. Digitrip RMS Ground Fault Protection Time-Current Curve SC4279-87

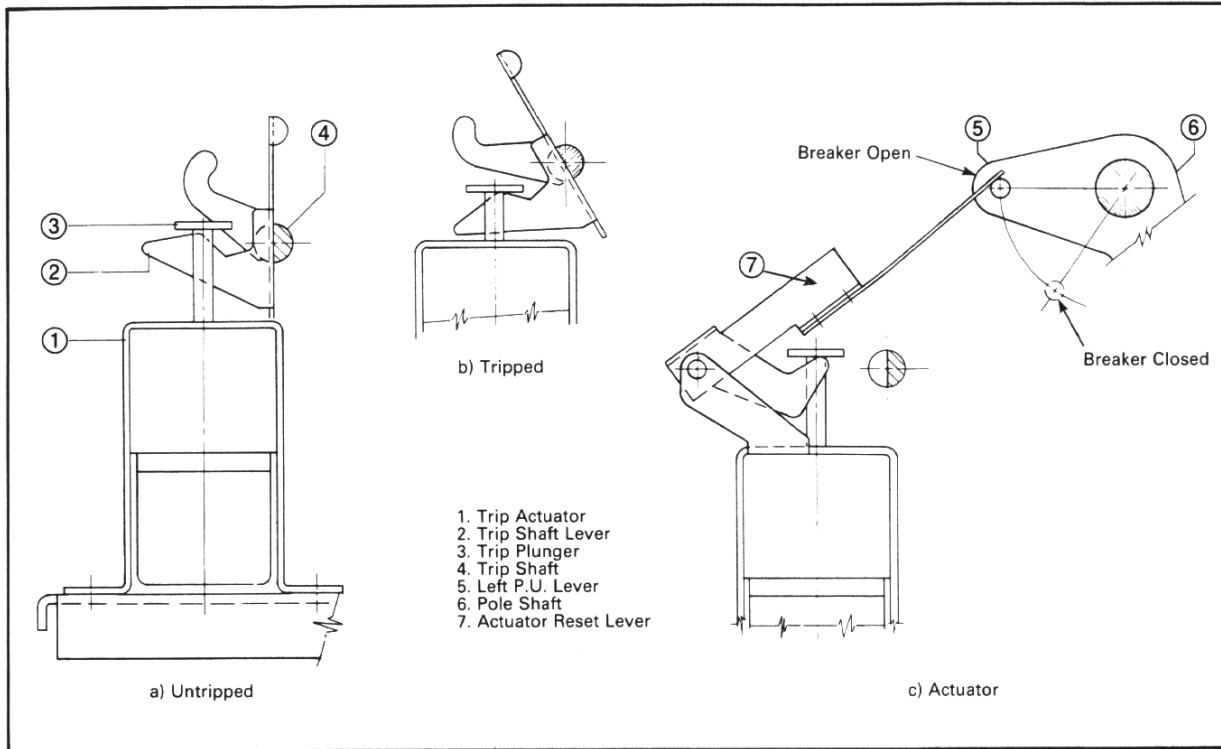

Fig. 3-9. Digitrip RMS Direct Trip Actuator (DTA)

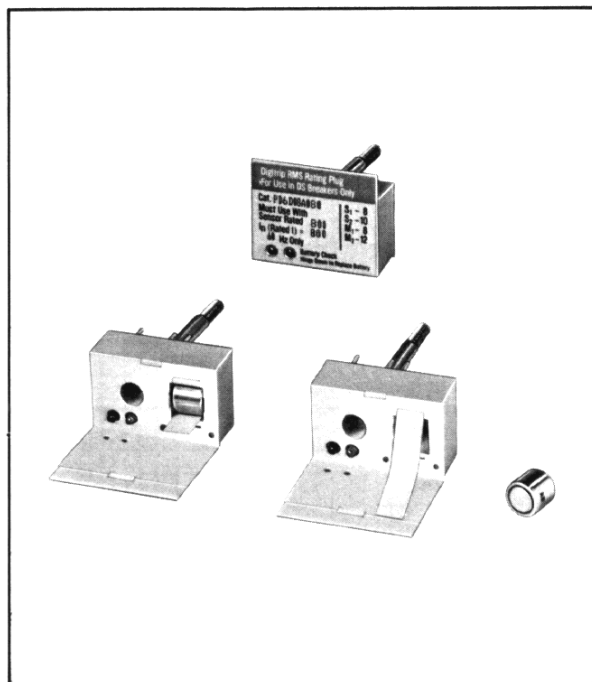

Fig. 3-10. Digitrip RMS Rating Plug and Battery

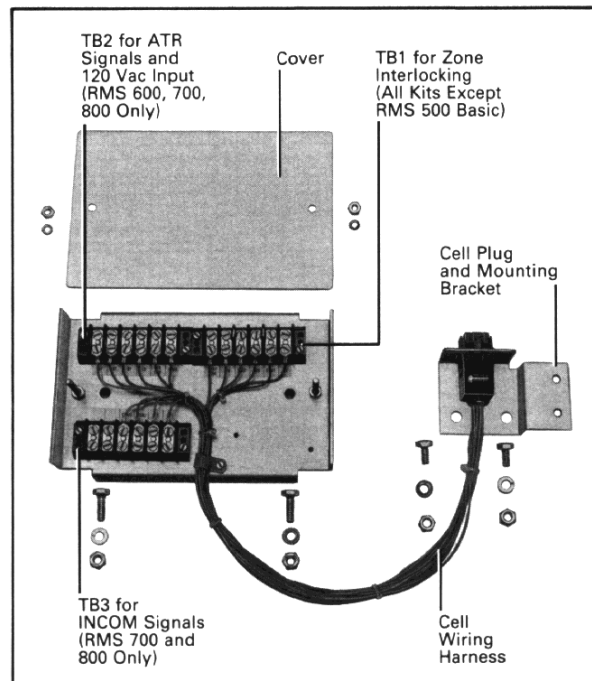

Fig. 3-11. Cell Plug, Wiring Harness, and Terminal Block Assembly



## Section 4

Digitrip RMS 500 Basic Retrofit Kits  
(without Zone Interlocking)

## 4-1. Digitrip RMS 500 Basic Retrofit Kit Selection and Content

The Digitrip RMS 500 Basic Retrofit Kit series provides basic overcurrent protection only. The available retrofit kit styles are shown in Fig. 4-1, listed with the applicable Digitrip RMS 500 Trip Unit overcurrent trip functions, i.e. Long Time (L), Short Time (S), Instantaneous (I), and Ground Fault Time (G) Delays. Select the retrofit kit style to provide simple replacement of the existing Amptector overcurrent trip functions for the DS or DSL breaker to be retrofitted.

The complete Digitrip RMS 500 Basic Retrofit Kit bill of material is listed in Fig. 4-2. Fig. 4-3 provides the retrofit kit wiring connections on the breaker. All retrofit kit components are mounted on the breaker. Zone interlocking signals from the trip unit are shorted out at the trip unit box terminal strip and are not wired out from the breaker.

## 4-2. Digitrip RMS 500 Basic Retrofit Kit Features

The Digitrip RMS 500 Trip Unit has the following features available for customer use, when applied in the Digitrip RMS 500 Basic Retrofit Kit:

1. Basic (L,S,I,G) Overcurrent Protection, as selected.
2. True RMS Sensing.
3. Integral Trip Unit Testing.
4. Unit Status LED.
5. Local Mode of Trip LEDs.
6. Selectable  $I^2t$  on Short Time and Ground Fault Time Delays when those options are selected.

The trip unit also includes provisions to accept the required rating plug. The rating plug is equipped with a battery to power the local mode of trip LEDs.

Fig. 4-1 DS and DSL RMS 500 Basic Retrofit Kits (Without Zone Interlocking)				
Digitrip RMS Retrofit Kit Style	Breaker Type DS and DSL	Digitrip RMS 500 Trip Unit Provided in Kit		Trip Unit Box Style Number Provided in Kit
		Trip Functions	Catalog No.	
8188A20G01	DS206 - DS840	LI	T51BLI	6502C70G01
8188A20G02	DS206 - DS840	LS	T53BLS	6502C70G01
8188A20G03	DS206 - DS840	LSI	T52BLSI	6502C70G01
8188A20G04	DS206 - DS840	LIG	T54BLIG	6502C70G02
8188A20G05	DS206 - DS840	LSG	T55BLSG	6502C70G02
8188A20G06	DS206 - DS840	LSIG	T56BLSIG	6502C70G02

Fig. 4-2 Digitrip RMS 500 Basic Retrofit Kit (Without Zone Interlocking) Bill of Material		
Qty	Description	Style
1	Instruction Leaflet, DS Digitrip RMS Retrofit Kits	I.L. 33-854
1	Digitrip RMS 500 Trip Unit (without Rating Plug)	Fig. 4-1
1	Trip Unit Box	Fig. 4-1
1	Set Retrofit Kit Parts Includes:	8188A26G01
1	Direct Trip Actuator (DTA), Style 6482C55G03	
1	OTS Reset Lever (Flapper)	
2	DTA/OTS Reset Lever Rivets (1.25 X 0.63-0.125)	
1	Trip Unit Cover Assembly, Style 8293A12G01, Includes:	
1	Plastic Trip Unit Cover	
4	#4-40 Thumbscrews	
4	#4 Flat Washer	
4	#4 Fiber Washer	
1	Retrofit Basic Hardware Kit, Style 8188A25G01, Includes:	
2	Digitrip RMS ID Labels (Breaker and Cell), Style 8187A63H01	
1	Warning Label, Amptector Test Kit, Style 8263A17H01	
5	DTA/OTS Nylock Hex Bolts (0.25-20 X 0.50)	
10	Nylon Wire Ties	

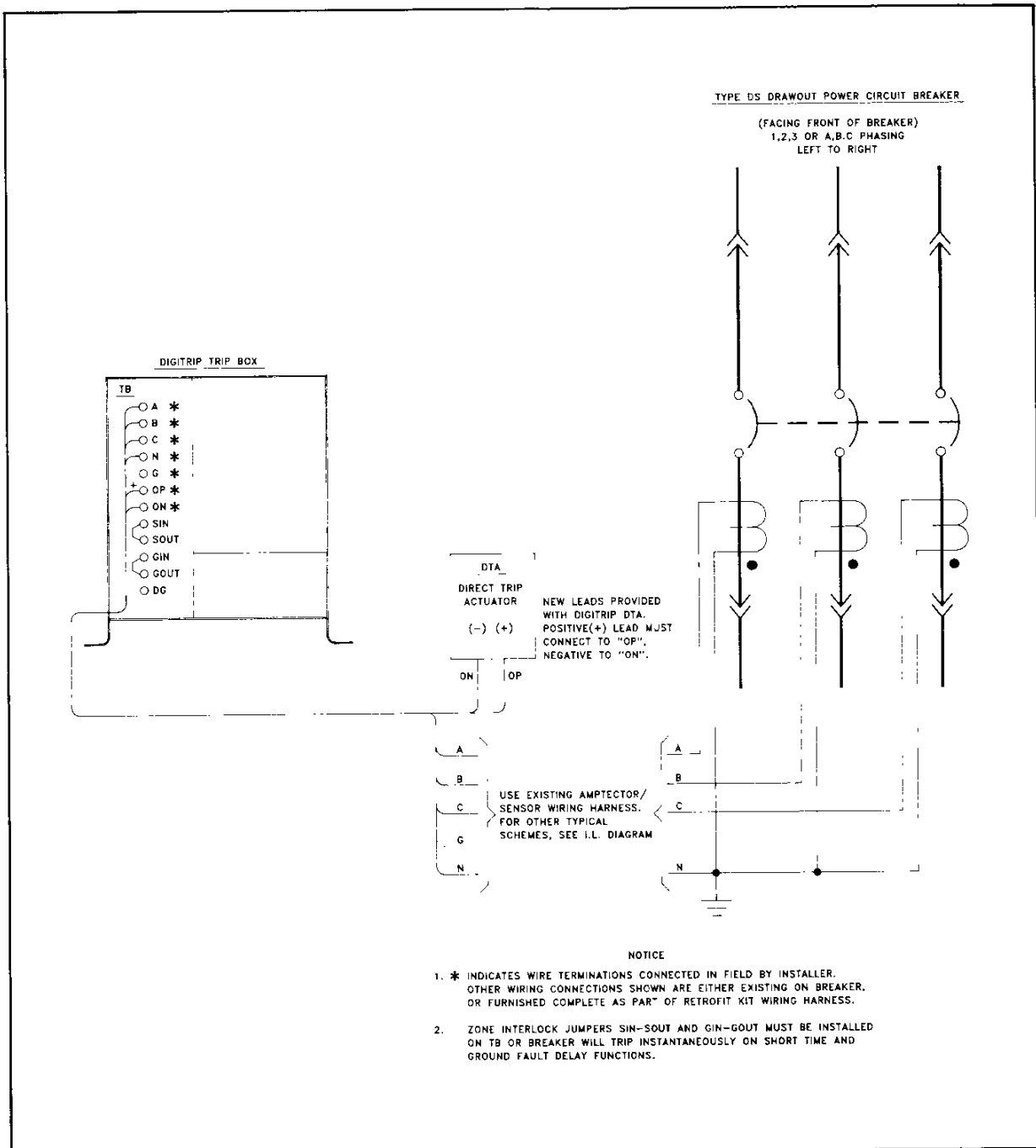

Fig. 4-3. Digitrip RMS 500 Basic Retrofit Kit Breaker Interface Diagram (without Zone Interlocking)

## Section 5

## Digitrip RMS 500 Retrofit Kits (with Zone Interlocking)

## 5-1. Digitrip RMS 500 Retrofit Kit (with Zone Interlocking) Selection and Content

The Digitrip RMS 500 Retrofit Kit series equipped with zone interlocking are shown in Fig. 5-1. The applicable Digitrip RMS 500 Trip Unit overcurrent trip functions, i.e. Long Time (L), Short Time (S), Instantaneous (I), and Ground Fault Time (G) Delays are listed. Select the retrofit kit style to provide simple replacement of the existing Amptector overcurrent trip functions for the DS or DSL breaker to be retrofitted.

The complete Digitrip RMS 500 Retrofit Kit bill of material is listed in Fig. 5-2. Figs. 5-3 and 5-4 provide the retrofit kit wiring connections on the breaker and the switchgear cell. Zone interlocking signals from the trip unit are extracted from terminals on the unit trip box by a umbilical wiring harness with plug. All retrofit kit components are mounted on the breaker, except the cell plug, wiring harness, and terminal block assembly, which is mounted in the switchgear cell. The umbilical plug connects to the cell plug, wiring harness, and terminal block assembly after the breaker is racked to the CONNECTED position.

## 5-2. Digitrip RMS 500 Retrofit Kit (with Zone Interlocking) Features

The Digitrip RMS 500 Trip Unit has the following features available for customer use, when applied in the Digitrip RMS 500 Basic Retrofit Kit:

1. Basic (L,S,I,G) Overcurrent Protection, as selected.
2. True RMS Sensing.
3. Integral Trip Unit Testing.
4. Unit Status LED.
5. Local Mode of Trip LEDs.
6. Selectable  $I^2t$  on Short Time and Ground Fault Time Delays when those options are selected.
7. Zone interlock capabilities of the breaker Short Time and Ground Fault Delay functions, when those options are selected.

The trip unit also includes provisions to accept the required rating plug. The rating plug is equipped with a battery to power the Local Mode of Trip LEDs.

Fig. 5-1  
DS and DSL RMS 500 Retrofit Kits (with Zone Interlocking)

Digitrip RMS Retrofit Kit Style	Breaker Type DS and DSL	Digitrip RMS 500 Trip Unit Provided in Kit		Trip Unit Box and Umbilical Harness Style in Kit
		Trip Functions	Catalog No.	
8188A20G07	DS206 - DS840	LI	T51BLI	6502C70G03
8188A20G08	DS206 - DS840	LS	T53BLS	6502C70G03
8188A20G09	DS206 - DS840	LSI	T52BLSI	6502C70G03
8188A20G10	DS206 - DS840	LIG	T54BLIG	6502C70G04
8188A20G11	DS206 - DS840	LSG	T55BLSG	6502C70G04
8188A20G12	DS206 - DS840	LSIG	T56BLSIG	6502C70G04

**Fig. 5-2**  
**Digitrip RMS 500 Retrofit Kit (with Zone Interlocking)**  
**Bill of Material**

Qty	Description	Style
1	Instruction Leaflet, DS Digitrip RMS Retrofit Kits	I.L. 33-854
1	Digitrip RMS 500 Trip Unit (without Rating Plug)	Fig. 5-1
1	Trip Unit Box and Umbilical Wiring Harness with Plug	Fig. 5-1
1	Set Retrofit Kit Parts Includes:	8188A26G02
	1 Direct Trip Actuator (DTA), Style 6482C55G03	
	1 OTS Reset Lever (Flapper)	
	2 DTA/OTS Reset Lever Rivets (1.25 X 0.63-0.125)	
	1 Wire Guide Bracket	
	1 Cell Plug, Wiring Harness and Terminal Block Assembly, Style 6502C71G01, including:	
	2 Hex Bolts (0.25-20 X 0.50)	<b>Note:</b> This hardware for use in mounting cell plug, wiring harness, and terminal block assembly.
	4 Lockwasher (0.25)	
	4 Flat Washer (0.25)	
	2 Hex Nut (0.25-20)	
	1 Trip Unit Cover Assembly, Style 8293A12G01, Includes:	
	1 Plastic Trip Unit Cover	
	4 #4-40 Thumbscrews	
	4 #4 Flat Washer	
	4 #4 Fiber Washer	
	1 Retrofit Hardware Kit, Style 8188A25G02, Includes:	
	2 Digitrip RMS ID Labels (Breaker and Cell), Style 8187A63H01	
	1 Warning Label, Amptector Test Kit, Style 8263A17H01	
	5 DTA/OTS Nylock Hex Bolts (0.25-20 X 0.50)	
	8 Wire Support Clip (Stick-on Type)	
	10 Nylon Wire Ties	

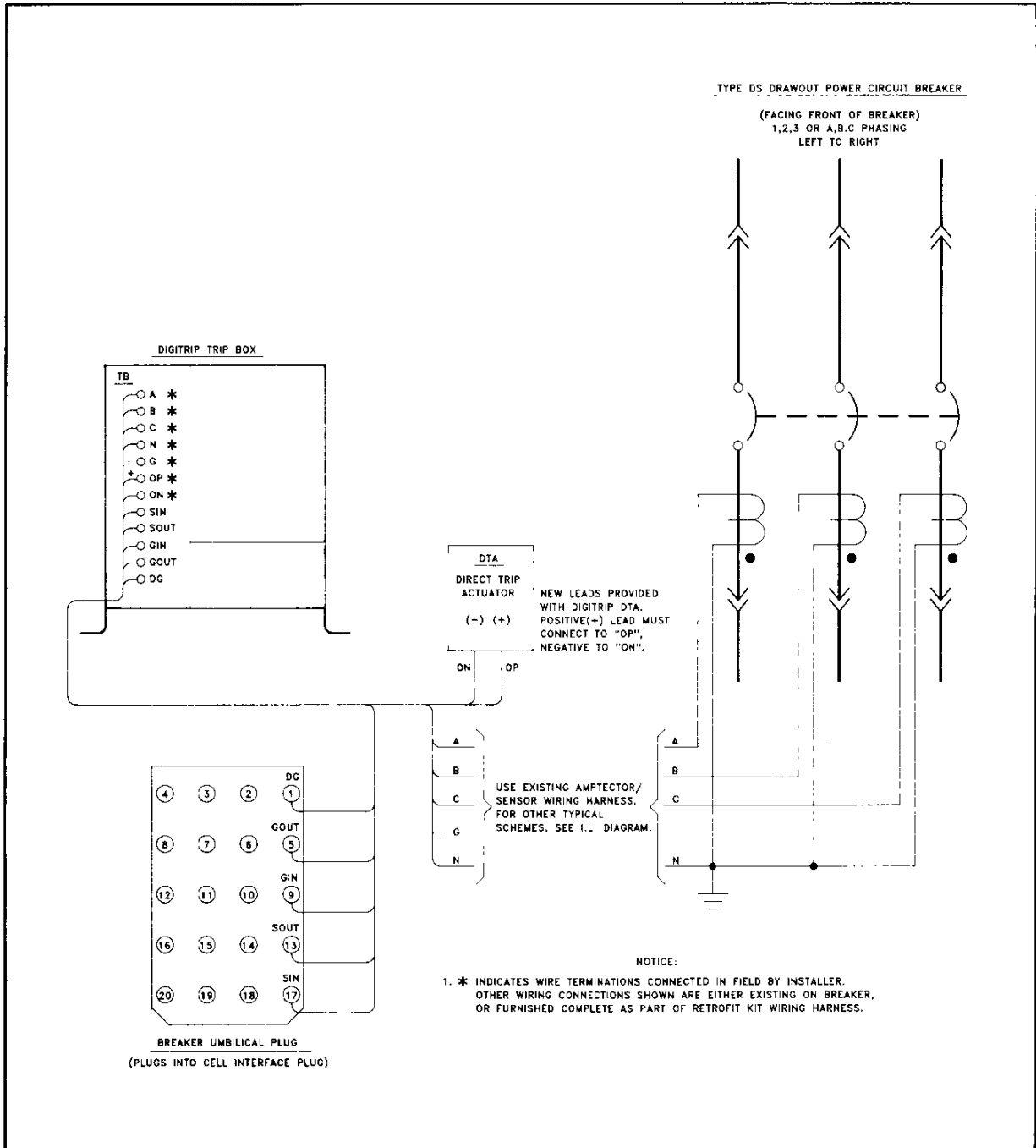

Fig. 5-3. Digitrip RMS 500 Retrofit Kit Breaker Interface Diagram (with Zone Interlocking)

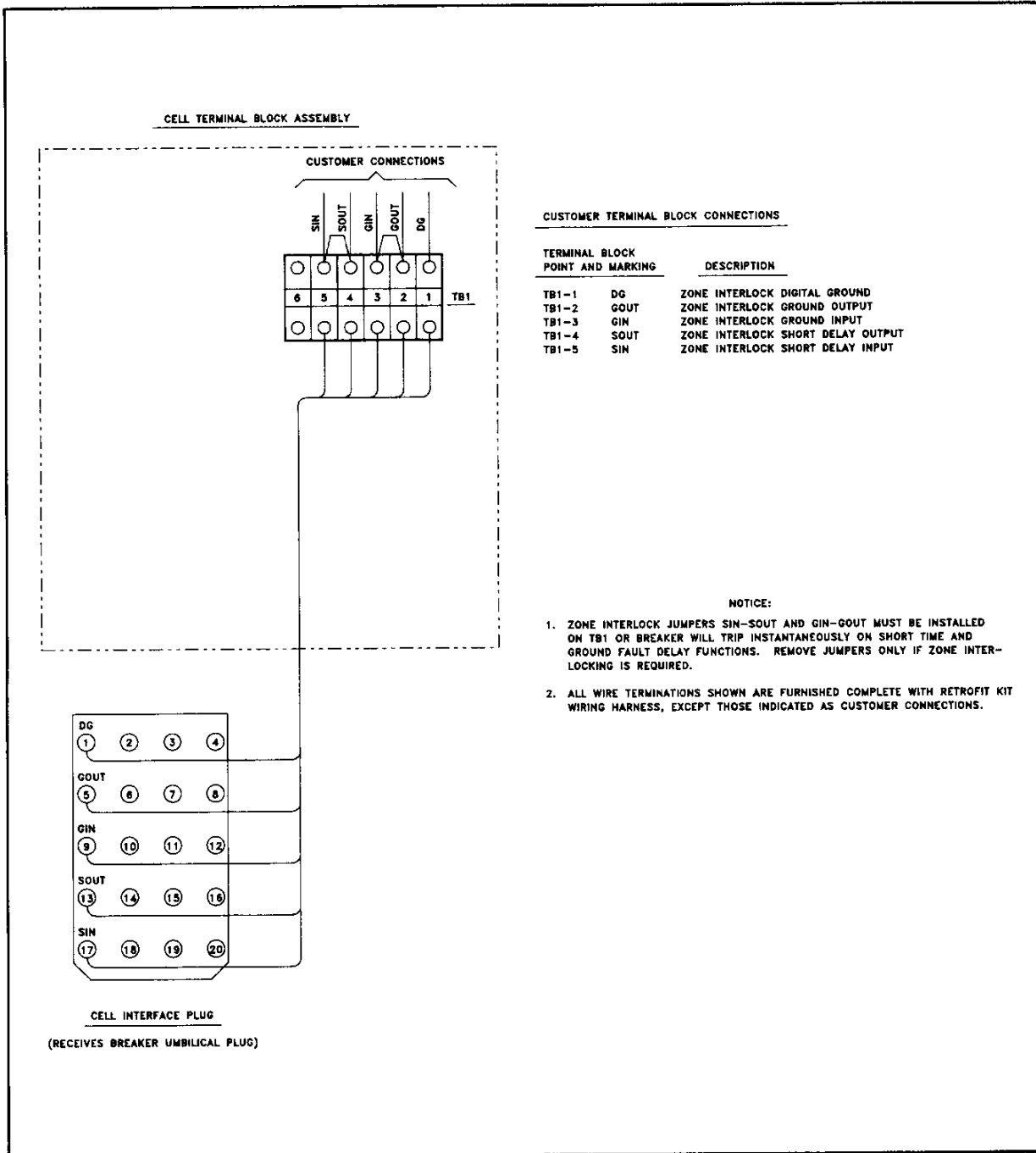

Fig. 5-4. Digitrip RMS 500 Retrofit Kit Switchgear Cell Interface Diagram (with Zone Interlocking)

## Section 6

### Digitrip RMS 600 Retrofit Kits

#### 6-1. Digitrip RMS 600 Retrofit Kit Selection and Content

The Digitrip RMS 600 Retrofit Kit series are shown in Fig. 6-1. The applicable Digitrip RMS 600 Trip Unit overcurrent trip functions, i.e. Long Time (L), Short Time (S), Instantaneous (I), and Ground Fault Time (G) Delays are listed. Select the retrofit kit style to provide simple replacement of the existing Amptector overcurrent trip functions for the DS or DSL breaker to be retrofitted.

The complete Digitrip RMS 600 Retrofit Kit bill of material is listed in Fig. 6-2. Figs. 6-3 and 6-4 provide the retrofit kit wiring connections on the breaker and in the switchgear cell. Zone interlocking signals from the trip unit are extracted from terminals on the unit trip box and remote alarm signals are extracted from the Power Relay Module (ATR) by a umbilical wiring harness with plug. The umbilical plug connects to the cell plug, wiring harness, and terminal block assembly after the breaker is racked to the CONNECTED position.

An external 120 Vac control source is required to power up the Power Relay Module (ATR) remote signals and the trip unit alphanumeric digital display. All retrofit kit components are mounted on the breaker, except the cell plug, wiring harness, and terminal block assembly, which is mounted in the switchgear cell.

#### 6-2. Digitrip RMS 600 Retrofit Kit Features

The Digitrip RMS 600 Trip Unit has the following features available for customer use, when applied in the Digitrip RMS 600 Retrofit Kit:

1. Basic (L,S,I,G) Overcurrent Protection, as selected.
2. True RMS Sensing.
3. Integral Trip Unit Testing.
4. Unit Status LED.
5. Local Mode of Trip LEDs.
6. Selectable  $I^2t$  on Short Time and Ground Fault Time Delays when those options are selected.
7. Zone Interlock capabilities of the breaker Short Time and Ground Fault Delay functions, when those options are selected.
8. Local Four Digit Alpha-Numeric Display.
9. Remote Signal Contacts for high load and mode of trip indication.

The trip unit also includes provisions to accept the required rating plug. The rating plug is equipped with a battery to back-up the external 120 Vac power source, which powers the local mode of trip LEDs through the Power Relay Module (ATR).

**Fig. 6-1**  
**DS and DSL Breaker Digitrip RMS 600 Retrofit Kits**

Digitrip RMS Retrofit Kit Style	Breaker Type DS and DSL	Digitrip RMS 600 Trip Unit Provided in Kit		Trip Unit Box and Umbilical Harness Style in Kit
		Trip Functions	Catalog No.	
8188A21G01	DS206 - DS840	LI	T61BLI	6502C70G05
8188A21G02	DS206 - DS840	LS	T63BLS	6502C70G05
8188A21G03	DS206 - DS840	LSI	T62BLSI	6502C70G05
8188A21G04	DS206 - DS840	LIG	T64BLIG	6502C70G06
8188A21G05	DS206 - DS840	LSG	T65BLSG	6502C70G06
8188A21G06	DS206 - DS840	LSIG	T66BLSIG	6502C70G06

**Fig. 6-2**  
**Digitrip RMS 600 Retrofit Kit**  
**Bill of Material**

Qty	Description	Style
1	Instruction Leaflet, DS Digitrip RMS Retrofit Kits	I.L. 33-854
1	Digitrip RMS 600 Trip Unit (without Rating Plug)	Fig. 6-1
1	Trip Unit Box and Umbilical Wiring Harness with Plug Includes:	Fig. 6-1
1	1 Power/Relay Module (ATR) Wired to Box and Harness	
1	Set Retrofit Kit Parts Includes:	8188A26G03
1	1 Direct Trip Actuator (DTA), Style 6482C55G03	
1	1 OTS Reset Lever (Flapper)	
2	2 DTA/OTS Reset Lever Rivets (1.25 X 0.63-0.125)	
1	1 Wire Guide Bracket	
1	1 Cell Plug, Wiring Harness and Terminal Block Assembly, Style 6502C71G02	
2	2 Hex Bolts (0.25-20 X 0.50)	<b>Note:</b> This hardware for use in mounting cell plug, wiring harness, and terminal block assembly.
4	4 Lockwasher (0.25)	
4	4 Flat Washer (0.25)	
2	2 Hex Nut (0.25-20)	
1	1 Trip Unit Cover Assembly, Style 8293A12G01, Includes:	
1	1 Plastic Trip Unit Cover	
4	4 #4-40 Thumbscrews	
4	4 #4 Flat Washer	
4	4 #4 Fiber Washer	
1	1 Retrofit Hardware Kit, Style 8188A25G02, Includes:	
2	2 Digitrip RMS ID Labels (Breaker and Cell), Style 8187A63H01	
1	1 Warning Label, Amptector Test Kit, Style 8263A17H01	
5	5 DTA/OTS Nylock Hex Bolts (0.25-20 X 0.50)	
8	8 Wire Support Clip (Stick-on Type)	
10	10 Nylon Wire Ties	



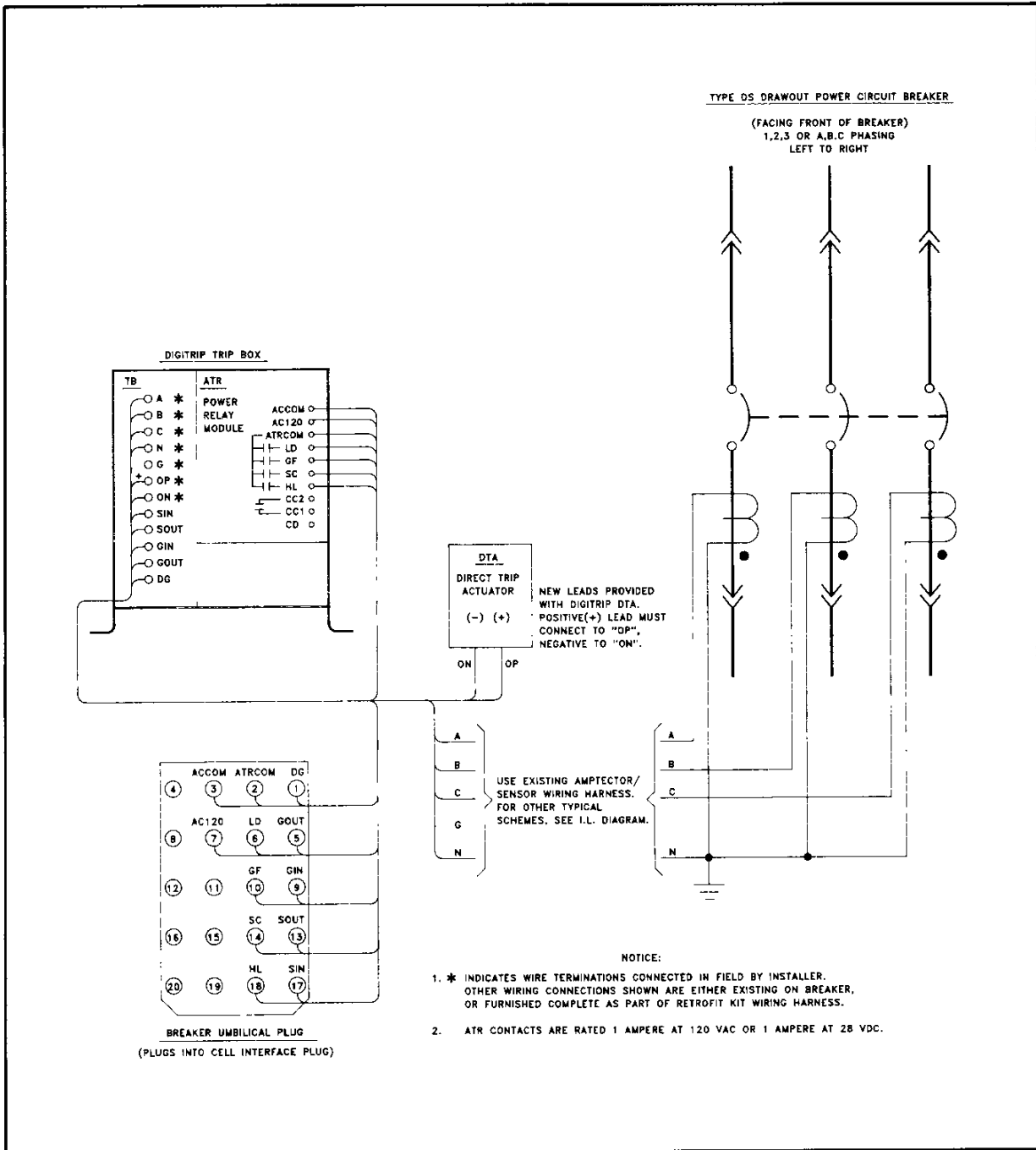
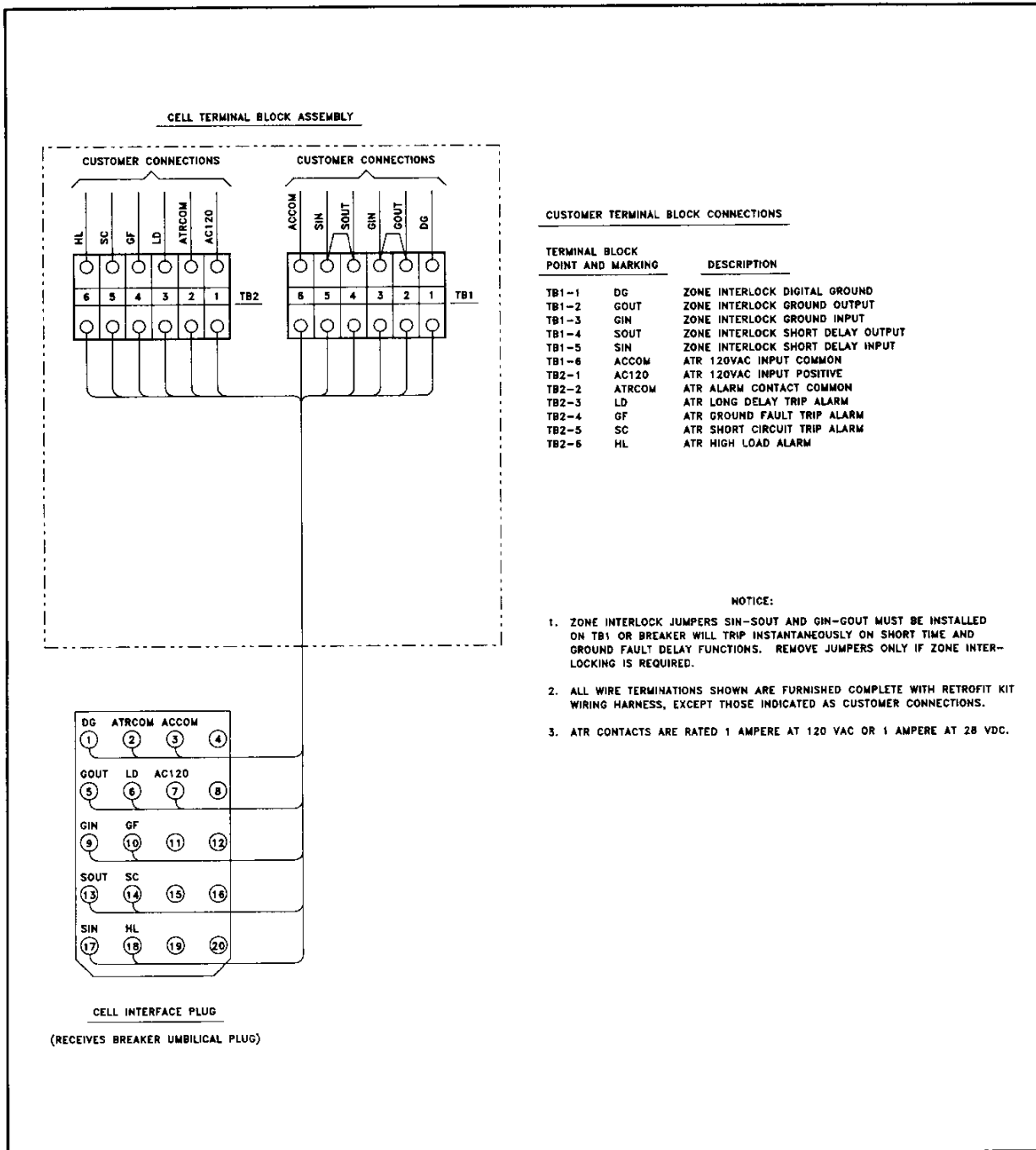

Fig. 6-3. Digitrip RMS 600 Retrofit Kit Breaker Interface Diagram



**Fig. 6-4. Digitrip RMS 600 Retrofit Kit Switchgear Cell Interface Diagram**

## Section 7

## Digitrip RMS 700 and 800 Retrofit Kits

## 7-1. Digitrip RMS 700 and 800 Retrofit Kit Selection and Content

The Digitrip RMS 700 and 800 Retrofit Kit series are shown in Figs. 7-1 and 7-2. The applicable Digitrip RMS Trip Unit overcurrent trip functions, i.e. Long Time (L), Short Time (S), Instantaneous (I), and Ground Fault Time (G) Delays are listed. Select the retrofit kit style to provide simple replacement of the existing Amptector overcurrent trip functions for the DS or DSL breaker to be retrofitted.

The complete Digitrip RMS 700 and 800 Retrofit Kit bills of material is listed in Fig. 7-3. Figs. 7-4 and 7-5 provide the retrofit kit wiring connections on the breaker and in the switchgear cell.

Digitrip RMS 700 and 800 Retrofit Kits feature INCOM Communications capability when applied with the Westinghouse Integrated Monitoring Protection and Control Communications (IMPACC) System. Digitrip RMS 700 and 800 Retrofit Kits are identical, except that the RMS 800 Trip Unit has an Alphanumeric Digital Display. INCOM Communication and zone interlocking signals from the trip unit are extracted from terminals on the unit trip box and remote alarm signals are extracted from the Power Relay Module (ATR) by a umbilical wiring harness with plug. The umbilical plug connects to the cell plug, wiring harness, and terminal block assembly, after the breaker is racked to the CONNECTED position.

An external 120 Vac control source is required to power up the Power Relay Module (ATR) remote signals, INCOM Communications, and the RMS 800 Trip Unit Alphanumeric Digital Display. A Potential Transformer Module (PTM) provides the distribution system voltage input to the trip unit. The PTM is

provided with a disconnect plug which is to be disconnected in the event of breaker dielectric testing. All retrofit kit components are mounted on the breaker, except the cell plug, wiring harness, and terminal block assembly, which is mounted in the switchgear cell.

## 7-2. Digitrip RMS 700 and 800 Retrofit Kit Features

Digitrip RMS 700 and 800 Trip Units have the following features available for customer use, when applied in Digitrip RMS Retrofit Kits:

1. Basic (L,S,I,G) overcurrent protection, as selected.
2. True RMS Sensing.
3. Integral Trip Unit Testing.
4. Unit Status LED.
5. Local Mode of Trip LEDs.
6. Selectable I<sup>2</sup>t on Short Time and Ground Fault Time delays when those options are selected.
7. Zone Interlock capabilities of the breaker Short Time and Ground Fault Delay functions, when those options are selected.
8. Local Four Digit Alpha-Numeric Display (Digitrip RMS 800 only).
9. Remote Signal Contacts for high load and mode of trip indication.
10. INCOM Communications when applied with the Westinghouse IMPACC System.
11. Energy Monitoring Capability.

The trip unit also includes provisions to accept the required rating plug. The rating plug is equipped with a battery to back-up the external 120 Vac power source, which powers the local mode of trip LEDs through the Power Relay Module (ATR).

Fig. 7-1 DS and DSL Breaker Digitrip RMS 700 Retrofit Kits				
Digitrip RMS Retrofit Kit Style	Breaker Type DS and DSL	Digitrip RMS 700 Trip Unit Provided in Kit		Trip Unit Box and Umbilical Harness Style in Kit
		Trip Functions	Catalog No.	
8188A22G01	DS206 - DS840	LI	T71BLI	6502C70G07
8188A22G02	DS206 - DS840	LS	T73BLS	6502C70G07
8188A22G03	DS206 - DS840	LSI	T72BLSI	6502C70G07
8188A22G04	DS206 - DS840	LIG	T74BLIG	6502C70G08
8188A22G05	DS206 - DS840	LSG	T75BLSG	6502C70G08
8188A22G06	DS206 - DS840	LSIG	T76BLSIG	6502C70G08

Fig. 7-2 DS and DSL Breaker Digitrip RMS 800 Retrofit Kits				
Digitrip RMS *Retrofit Kit Style	Breaker Type DS and DSL	Digitrip RMS 800 Trip Unit Provided in Kit		Trip Unit Box and Umbilical Harness Style in Kit
		Trip Functions	Catalog No.	
8188A23G01	DS206 - DS840	LI	T81BLI	6502C70G07
8188A23G02	DS206 - DS840	LS	T83BLS	6502C70G07
8188A23G03	DS206 - DS840	LSI	T82BLSI	6502C70G07
8188A23G04	DS206 - DS840	LIG	T84BLIG	6502C70G08
8188A23G05	DS206 - DS840	LSG	T85BLSG	6502C70G08
8188A23G06	DS206 - DS840	LSIG	T86BLSIG	6502C70G08

**Fig. 7-3  
Digitrip RMS 700 and 800 Retrofit Kits  
Bill of Material**

Qty	Description	Style
1	Instruction Leaflet, DS Digitrip RMS Retrofit Kits	I.L. 33-854
1	Digitrip RMS 700 or 800 Trip Unit (No Rating Plug)	Fig. 7-1
1	Trip Unit Box and Umbilical Wiring Harness with Plug Includes:	or 7-2
	<ul style="list-style-type: none"> <li>1 Power/Relay Module (ATR)</li> <li>1 Potential Transformer Module (PTM) with Disconnect Plug and 3 #16 AWG Leads</li> <li>1 60 Inch Length of Insulation Tubing</li> <li>3 Ring Tongue Terminals, Non-Insl., 0.188 ID</li> <li>3 Ring Tongue Terminals, Non-Insl., 0.25 ID</li> <li>3 Ring Tongue Terminals, Non-Insl., 0.375 ID</li> </ul>	
1	Set Retrofit Kit Parts Includes:	8188A26G04
	<ul style="list-style-type: none"> <li>1 Direct Trip Actuator (DTA), Style 6482C55G03</li> <li>1 OTS Reset Lever (Flapper)</li> <li>2 DTA/OTS Reset Lever Rivets (1.25 X 0.63-0.125)</li> <li>1 Wire Guide Bracket</li> </ul>	
	<ul style="list-style-type: none"> <li>1 Cell Plug, Wiring Harness and Terminal Block Assembly, Style 6502C71G03</li> </ul>	
	<ul style="list-style-type: none"> <li>2 Hex Bolts (0.25-20 X 0.50)</li> <li>4 Lockwasher (0.25)</li> <li>4 Flat Washer (0.25)</li> <li>2 Hex Nut (0.25-20)</li> </ul>	<p><b>Note:</b> This hardware for use in mounting cell plug, wiring harness, and terminal block assembly.</p>
	<ul style="list-style-type: none"> <li>1 Trip Unit Cover Assembly, Style 8293A12G01, Includes:</li> </ul>	
	<ul style="list-style-type: none"> <li>1 Plastic Trip Unit Cover</li> <li>4 #4-40 Thumbscrews</li> <li>4 #4 Flat Washer</li> <li>4 #4 Fiber Washer</li> </ul>	
	<ul style="list-style-type: none"> <li>1 Retrofit Hardware Kit, Style 8188A25G02, Includes:</li> </ul>	
	<ul style="list-style-type: none"> <li>2 Digitrip RMS ID Labels (Breaker and Cell), Style 8187A63H01</li> <li>1 Warning Label, Amptector Test Kit, Style 8263A17H01</li> <li>5 DTA/OTS Nylock Hex Bolts (0.25-20 X 0.50)</li> <li>8 Wire Support Clip (Stick-on Type)</li> <li>10 Nylon Wire Ties</li> </ul>	

**NOTE:** A customer-supplied relay, Westinghouse BF or equivalent, will likely be required for remote close capability via INCOM. See Section 13-2.

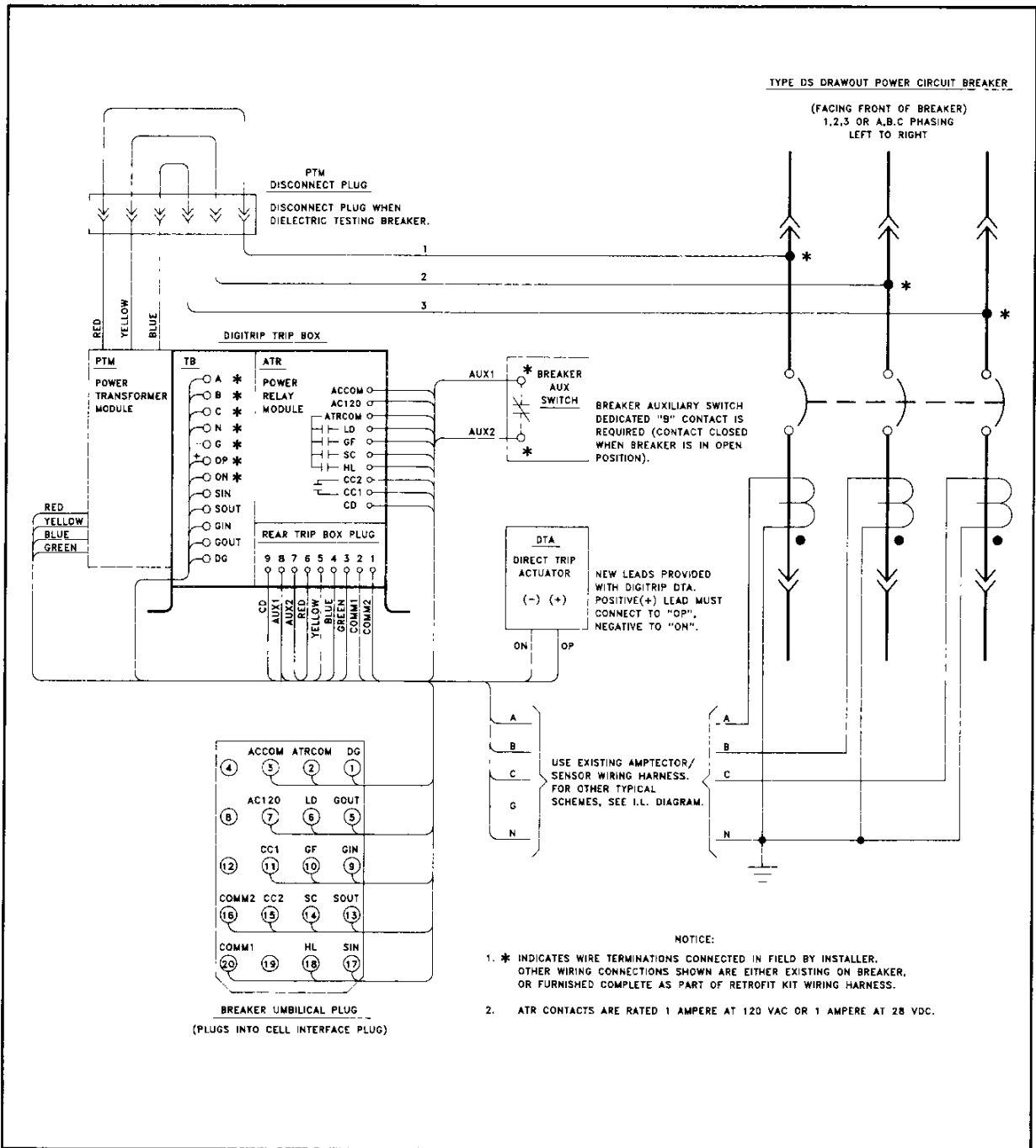
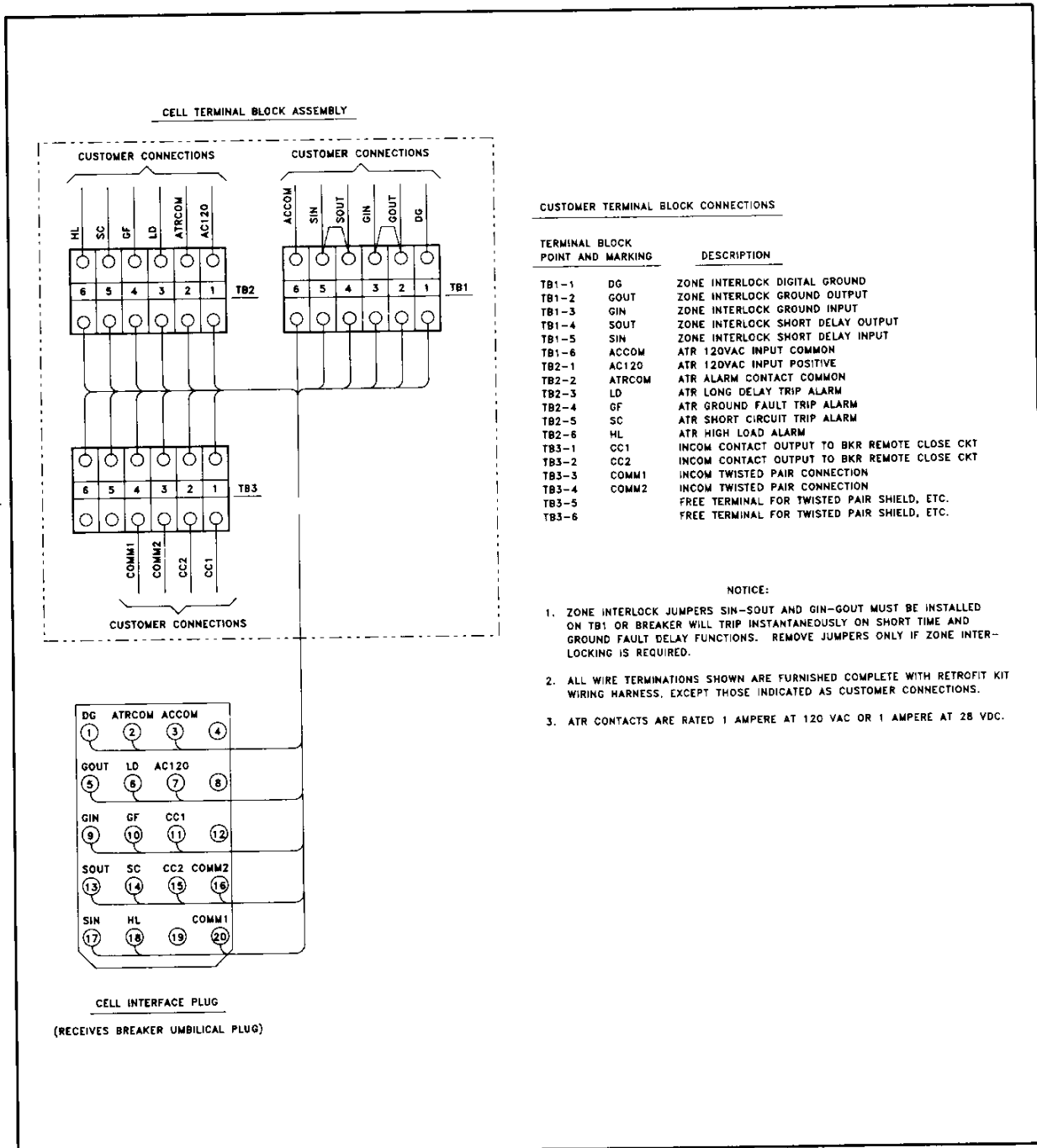

Fig. 7-4. Digitrip RMS 700 and 800 Retrofit Kit Breaker Interface Diagram



**Fig. 7-5. Digitrip RMS 700 and 800 Retrofit Kit Switchgear Cell Interface Diagram**

## Section 8

### General Preparation for Retrofit

#### 8-1. Tools and Accessories Recommended for Installation

The tools and accessories recommended for the various retrofit kit installations include the ones listed below:

##### 1. All Retrofit Kits

a. Ratchet (3/8") socket set with 7/16" to 3/4" sockets, straight edge, scribe, center punch, small (instrument size) and medium size screwdrivers, wire cutters, and hammer.

b. Electric Drill, 0.0890 (size 43) drill bit, 0.112-40" (#4-40) tap, tap holder, pliers.

c. Auxiliary Power Module (APM), Catalog Number PRTAAPM, for powering the Digitrip RMS Trip Unit during testing.

**Note:** A 120 Vac supply can be used, rather than an APM for powering Digitrip RMS 600, 700, and 800 during testing.

d. Adjustable 0-28 Vdc power supply (optional, for independent testing of the Direct Trip Actuator).

##### 2. Retrofit Kits with Cell Plug, Wiring Harness, and Terminal Block Assemblies

a. 0.257 (size F) to 0.266 (size H) drill bit for 0.25 clearance hole.

b. Metal hack saw, flat metal file, Acrylic Laquer (e.g. Krylon), pencil type paint brush.

##### 3. Digitrip RMS 600, 700, and 800 Retrofit Kits

a. Wire strippers and crimpers (suitable for use with #16 AWG wire).

b. Ohmmeter.

##### 4. Breakers Equipped with Overcurrent Trip (OTS) Switches

Pop Rivet Gun (suitable for installing 1.25 long X 0.125 steel rivets) and Feeler gage (0.030").

## Section 9

### Breaker Element Retrofit Kit Installation Procedure

#### WARNING

REFER TO SECTION 1 ENTITLED "GENERAL INFORMATION AND SAFETY PRECAUTIONS" AND REVIEW ALL THE DIRECTIONS SET FORTH IN THAT SECTION, PRIOR TO STARTING THE RETROFIT KIT INSTALLATION. FAILURE TO FOLLOW SAFE PRACTICES RECOMMENDED IN SECTION 1 COULD RESULT IN PERSONAL INJURY, DEATH AND/OR EQUIPMENT DAMAGE. THIS INSTALLATION SHOULD ONLY BE CARRIED OUT BY PERSONNEL FAMILIAR WITH THE HAZARDS ASSOCIATED WITH WORKING ON POWER CIRCUIT BREAKERS AND SWITCHGEAR ASSEMBLIES.

Read the information provided in this manual and become familiar with its contents. Check the items received in the retrofit kit against the Digitrip RMS Style Number bill of material listed in this leaflet. Some items supplied may not be required for the breaker retrofitted and will be left over after the retrofit kit installation is completed. The following steps identified herein are required to install the retrofit kit components on the breaker element.

#### 9-1. Breaker Preparation

1. Remove the breaker element from the switchgear assembly. Take it to a well lighted work area to install the retrofit kit.
2. Confirm the breaker position indicator on the breaker faceplate reads "OPEN" and the spring charged indicator reads "DISCHARGED".
3. Use the breaker levering crank to lever the breaker element levering mechanism until the indicator reads the "TEST" position. This will permit the breaker to be open and closed, as required, during the installation.
4. Take off the breaker faceplate by removing the four (4) screws (6 screws for DS-632 and 840) that hold it to the breaker. This will provide access to the breaker front, similar as shown in Fig. 9-1.
5. Familiarize yourself with the applicable breaker diagrams for your retrofit. Refer to the typical trip unit box overcurrent harness and sensor connection schemes shown in Fig. 9-2. Also refer to the applicable breaker interface diagram, Figs. 4-3, 5-3, 6-3, or 7-3.

#### 9-2. Amptector Trip Unit Removal

1. Identify, tag with masking tape, and remove the existing leads from Amptector Trip Unit terminals A through ON.
2. Refer to Fig. 9-1. Cut the ring tongue terminals off the ends of existing terminal leads OP and ON and remove them from the wire bundle going to the Direct Trip Actuator (DTA). Later, these leads will be replaced with new leads supplied with the new Digitrip RMS DTA.
3. Place the remaining overcurrent wiring harness bundle (with rubber grommet) out of the way for future connection to Digitrip RMS.

4. Remove the two 0.25-20 screws that secure the Amptector Trip Unit to the breaker platform. Remove the Amptector Trip Unit from the breaker platform.

#### 9-3. Wire Guide Bracket Installation (All Kits Except RMS 500 Basic)

If the breaker is equipped with a U shaped metal wiring guide behind the Amptector Trip Unit, the wiring guide must be removed and replaced with the wiring guide bracket provided in the kit. The new wiring guide bracket will permit the Digitrip RMS zone interlocking wire harness to be routed behind the trip unit box.

1. Take off the existing wiring guide by removal of the two (2) 0.25-20 sems screws that hold it to the breaker platform.

**Note:** The right-hand screw holding the wiring guide may be located under the wiring bundle from the auxiliary switches. If required, cut the nylon wire clamps that hold the bundle together and gently push the bundle out of the way to obtain access to this screw.

2. Install the new wiring guide to the breaker platform with the two (2) existing 0.25-20 sems screws.

#### 9-4. Trip Unit Box and Trip Unit Installation

1. Refer to Fig. 9-1. Mount the Trip Unit Box, Fig. 3-4, on the breaker in the same location as the Amptector Trip Unit using the two (2) existing screws.
2. Lay the overcurrent wiring harness into the Digitrip RMS Trip Box and slip the rubber grommet into the slot of the trip unit box. Transpose and connect all terminal leads as previously tagged (except terminals OP and ON) to the Trip Unit Box terminal strip leads per Fig. 9-2.
3. Plug the Digitrip RMS Trip Unit into the trip unit box. The trip unit edge-card must seat completely and properly in the trip unit box edge-card receptacle. For RMS 700 and 800 models, the trip unit must also plug into the rear trip unit box plug.

#### 9-5. Rating Plug Installation

Your Digitrip RMS Retrofit Kit does not include the Digitrip RMS Rating Plug. The rating plug, Fig. 3-10 is ordered and supplied separately by the retrofit kit user. Rating plugs require coordination with current sensor ratings as shown in Fig. 2-2. Once obtained, the rating plug is installed as follows:

1. Confirm that the rating plug has the correct catalog number required for the DS breaker type, sensor, and the  $I_n$  rating as shown in Fig. 2-2.
2. Install the rating plug by opening the snap down cover, pushing the plug into the Digitrip RMS Trip Unit receptacle, and tightening the screw into the trip unit box.

**Note:** The trip unit edge card-connector must seat properly in the trip unit box before the rating plug is installed.



### 9-6. Wiring Harness Connection to Breaker "Free b" Contact (RMS 700 and 800 only)

Digitrip RMS models 700 and 800 require a "free b" (normally closed when breaker open) contact from the breaker auxiliary switch.

1. Remove the cover from the associated auxiliary switch stage, like shown in Figs. 3-1 or 9-1. Examine the breaker auxiliary switch configuration and determine with an ohmmeter the available b (nc) switch contact to be used.

**Note:** The auxiliary switch contact must be free for use. It should not be used in the breaker internal wiring or employed in remote indication or relay schemes. If an auxiliary switch does not exist or if a dedicated b contact is not available, refer to Fig. 2-3 to identify, order, and obtain the correct switch parts.

2. "Free up" this contact by removing any existing leads from contact terminals that connect the contact to the breaker secondary disconnects.

3. The RMS 700 and 800 Trip Unit Box is equipped with an umbilical wiring harness as shown in Fig. 3-4. Two leads (AUX1 and AUX2) with ring-tongue terminals project from the umbilical harness for connection across the breaker auxiliary switch b contact.

a. If the breaker is equipped with an RC type auxiliary switch, Fig. 3-1, remove the screw and stab type connector on the switch terminals. Install the ring-tongue leads to the switch and the replace auxiliary switch cover.

b. If the breaker is equipped with an Electroswitch type auxiliary switch, Fig. 9-1, cut off the ring-tongue terminals from the ends of AUX1 and AUX2. Strip and crimp on 2 slip-on terminals to the leads and slide them over the switch terminals. Install the auxiliary switch cover.

### 9-7. Potential Transformer Module (PTM) Connection to Breaker (RMS 700 and 800 only)

Digitrip RMS models 700 and 800 are equipped with a Potential Transformer Module (PTM) mounted on the side of the Trip Unit Box as shown in Fig. 3-4. The PTM provides three phase voltage input to trip unit when the breaker is placed in service.

1. Refer to Fig. 3-2. Route the three #16AWG PTM leads to the rear of the breaker by placing the leads inside the left side breaker wiring channel.
2. Cut the insulated wire tubing (approximately 60 inches provided) into three equal lengths. Slip each piece of tubing over the ends of the three (3) PTM leads.
3. Remove the primary disconnecting contacts from the upper set of circuit breaker studs at the rear of the breaker.
4. Refer to Fig. 3-2. Remove one hex bolt (including flat and lock washer) that holds the upper stud assembly to the pole unit molded base on each phase. Select the proper set of three (3) ring tongue terminals from the retrofit kit to match to fit over the hex bolts removed.
5. Determine the final routing and length of the PTM leads to the hex bolt locations. Confirm proper phasing.

**Note:** The Standard breaker phasing is A, B, C or 1, 2, 3 left to right when facing the front of the breaker. The PTM phasing to the disconnect plug is Red, Yellow, Blue as A, B, C or 1, 2, 3. The phase inputs to the PTM must correspond to the sensor phase inputs to Digitrip RMS. Tagging the leads from the PTM disconnect plug to the breaker studs is recommended to assure the proper phasing connected.

6. Cut, strip, and crimp the leads using the ring tongue terminals provided. Install the lead terminals to the upper stud assembly on each phase using the existing hex bolts, flat and lockwashers. Dress the PTM leads using nylon wire ties to secure them to the rear of the breaker.

#### WARNING

WHEN INSTALLING PTM WIRES, AVOID SHARP CORNERS AND PATHS THAT COULD CAUSE INTERFERENCE BETWEEN THE WIRES, BREAKER ELEMENT AND SWITCHGEAR CELL. IMPROPER ROUTING OF THE PTM WIRES COULD RESULT IN DEATH, PERSONAL INJURY AND/OR EQUIPMENT DAMAGE.

7. Install the primary disconnecting contacts to the upper breaker stud assemblies.

### 9-8. Direct Trip Actuator (DTA) Installation

#### WARNING

USE ONLY THE PROPER DIGITRIP RMS STYLE DTA PROVIDED, OR THE CIRCUIT BREAKER MIGHT NOT TRIP, RESULTING IN DEATH, PERSONAL INJURY AND/OR EQUIPMENT DAMAGE.

1. Test by operating the Direct Trip Actuator (DTA), Fig. 9-3, several times before installing it. Alternately, pull back on the DTA reset lever to reset the DTA, then trip it by applying 24 Vdc to the DTA terminal leads. Be sure to observe the proper polarity to the positive lead.
2. Locate the existing Amptector type DTA on the breaker, Fig. 9-1. Find the trip shaft reset spring connecting the DTA frame to the breaker trip shaft (location shown in Fig. 9-3). Remove the end of the spring connected to the DTA. DO NOT LOOSE the spring.
3. If the breaker is equipped with an Overcurrent Trip (OTS) Switch, Fig. 9-4, it must be removed to provide access to the DTA. Remove the two hex bolts that secure the OTS switch to the DTA from the undercarriage of the breaker. Tag and disconnect the OTS switch wiring from the switch terminals and remove the OTS switch from the breaker.
4. Remove the three hex bolts that secure the existing DTA from the undercarriage of the breaker and remove the DTA (and leads OP and ON) from the breaker.
5. For DS breakers equipped with OTS switches, the OTS reset lever (flapper), Figs. 9-3, must be installed on the DTA reset bracket with the two pop rivets provided. Fig. 9-4 shows the flapper installed on the DTA.

6. Be sure the breaker is in the OPEN position. Reset the DTA and place it in position on the breaker as shown in Fig. 3-4. The DTA plunger should be positioned over the breaker trip shaft (View A). The spring finger of the DTA reset lever should be positioned on the left breaker pole unit lever (View B). Secure the DTA (and OTS Switch, if applicable) from the undercarriage of the breaker using the three nylock mounting bolts provided.

7. The new DTA is equipped with two 15 inch long leads (positive terminal marked) with spade type terminations. Route the DTA leads up the wire bundle located at the front left hand corner of the breaker and through the rubber grommet in the slot of the trip box. Connect the positive lead to trip unit box terminal OP and the other to ON. Dress the leads with nylon wire ties along the wire bundle length.

### WARNING

THE POSITIVE (+) DTA TERMINAL LEAD MUST BE CONNECTED TO DIGITRIP RMS TRIP BOX TERMINAL "OP" AND THE NEGATIVE (-) TERMINAL LEAD TO TRIP BOX TERMINAL "ON". FAILURE TO OBSERVE THE PROPER POLARITY WILL PROHIBIT THE DIRECT TRIP ACTUATOR FROM PROPERLY TRIPPING THE CIRCUIT BREAKER, WHICH COULD RESULT IN DEATH, PERSONAL INJURY AND/OR EQUIPMENT DAMAGE.

8. Reconnect the end of the trip shaft reset spring to the DTA frame.

### 9-9. Breaker Trip Shaft Adjustment Procedure

The trip shaft adjustment screw, Fig. 9-3, on the DTA frame must be adjusted to provide the correct breaker trip latch overlap. This procedure is as follows:

### WARNING

TO AVOID PERSONAL INJURY AND/OR EQUIPMENT DAMAGE, USE SUITABLE LENGTH TOOLS AND KEEP HANDS WELL AWAY FROM ANY CIRCUIT BREAKER MOVING PARTS, WHEN PERFORMING THIS PROCEDURE

1. Manually charge the closing spring and close the breaker.
2. Slowly rotate the trip shaft adjustment screw clockwise until the breaker trips. This is the "no overlap" position.
3. Rotate (back off) the adjustment screw 4 turns in the counterclockwise direction.

### 9-10. OTS Switch Adjustment Procedure (for Breakers Equipped with OTS Switches Only)

For DS breakers equipped with OTS switches, the OTS switch reset lever (flapper) must also be adjusted.

### WARNING

TO AVOID PERSONAL INJURY AND/OR EQUIPMENT DAMAGE, USE SUITABLE LENGTH TOOLS AND KEEP HANDS WELL AWAY FROM ANY CIRCUIT BREAKER MOVING PARTS, WHEN PERFORMING THIS PROCEDURE

1. Manually charge the closing spring and close the breaker.
2. Refer to Fig. 9-4, View A. Check with a feeler gage for a 0.030 inch gap between the OTS reset lever (flapper) and the OTS switch lever in the reset position. If necessary, adjust the flapper by slight and careful bending to achieve the 0.030 inch gap.
3. With Caution, turn the DTA reset bracket clockwise, as far as possible, to simulate an overcurrent condition without tripping the breaker. The flapper will push the OTS switch lever in the latched position as shown in View B. If the OTS switch does not latch, adjust the flapper as required. Release the latched position by lifting the OTS latch lever. Confirm the correct flapper adjustment by repeating this step at least twice.
4. Trip the breaker before proceeding to the next step.

### 9-11. Current Sensor Connections and Installation

Your Digitrip RMS Retrofit Kit is designed to use the existing current sensors and overcurrent wiring harness provided with the Amptector Trip System. The kit does not include current sensors, because in most cases, the existing current sensors on DS breakers can be used.

The current sensors require coordination with the Digitrip Rating Plugs as shown in Fig. 2-2. Sensor ratings of 150, 100, and 50:5 require replacement with 200:5 minimum rating sensors. Alternate sensor ratings can be purchased separately. If required, the sensors can be changed out according to this procedure:

1. Remove the primary disconnecting contacts from the lower set of breaker studs. The sensors may now be added or changed.

**Note:** Sensors on DS206 and DSL206 breakers have a small spacer (Style 794A965H01) inserted in the sensor inner window. Remove these spacers from the existing sensors and insert them in the inner window of the new sensors.

2. Transpose the overcurrent wiring harness from the existing sensors to the new sensor terminals per Fig. 9-2. For RMS 700 and 800 Kits, see Section 9-12 on positive power flow conventions.
3. Install the primary disconnects.

### 9-12. Positive Power Flow Conventions (RMS 700 and 800 Only)

Digitrip RMS 700 and 800 Kits have energy monitoring capability and can read both positive and negative power. Proper power flow conventions must be used to assure the trip unit reads positive power, when the power flow through the breaker is in the positive direction. The connected sensor polarity and the direction of power flow through the breaker are the determining factors, described as follows:

1. Standard Power Flow Convention (power flow top to bottom): In most cases, the breaker primary (line side) is on the upper and the secondary (load side) is on the lower stud assemblies, when the breaker is racked into its designated switchgear cell. The trip unit will read positive power when the current flows from top to bottom, provided the overcurrent wiring harness is connected to the sensor terminal polarity shown in Fig. 9-2. Power flow in the opposite direction (bottom to top) will then read as negative power.

2. Non-Standard Convention (power flow bottom to top): In some cases, the breaker primary (line side) is on the lower and the secondary (load side) is on the upper stud assemblies, when the breaker is racked into its designated switchgear cell. The trip unit will read positive power when the current flows from bottom to top, provided the sensor overcurrent wiring harness is connected to the sensor terminal polarity opposite to that shown in Fig. 9-2. Power flow in the opposite direction (top to bottom) will then read as negative power.

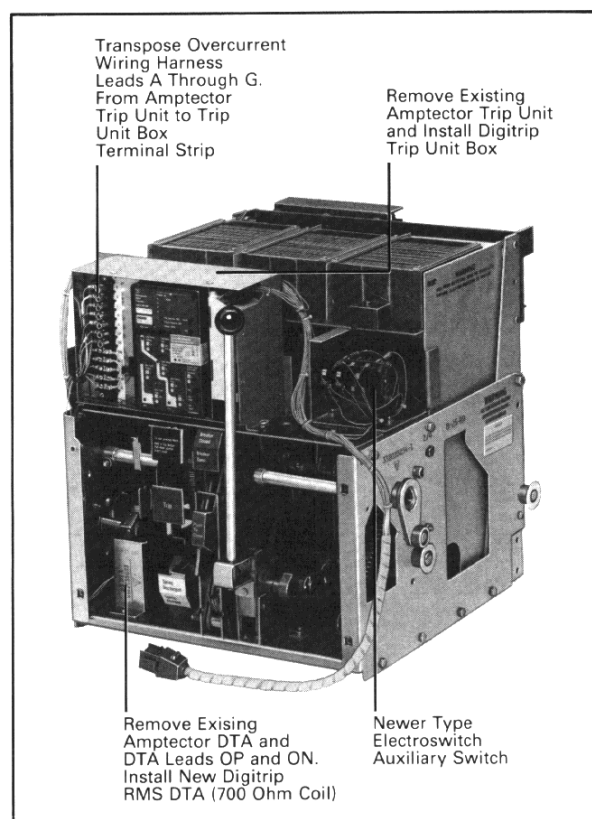

Fig. 9-1. DS Breaker Retrofit Kit Installation  
(Front Cover Removed)

### 9-13. Breaker Faceplate Modification

1. Refer to Fig. 9-5. Re-mount the breaker faceplate to the breaker using the hardware previously removed.

2. Place the clear plastic trip unit cover on the breaker faceplate over the Digitrip RMS Trip Unit cutout. Align and center the three port holes in the clear plastic cover over the trip unit "Trip Reset", "Step" (for Models 600 and 800), and Rating Plug "Battery Check" pushbuttons. Using the cover as a template, mark or scribe and then centerpunch the four corner hole center locations on the breaker faceplate.

3. Remove the breaker faceplate from the breaker and drill four (4) 0.0890 inch holes (size 43 drill) in the marked locations on the faceplate. Tap each hole with a #4-40 (0.112-40) tap.

4. For all kits, except the RMS 500 Basic, use a metal hack saw to small (1 inch X 1 inch) notch in the upper right hand corner of the faceplate. This permits the umbilical wiring harness to exit the breaker faceplate. After the notch has been cut, smooth out the rough edges and touch up the exposed metal with paint or a clear laquer.

5. Re-mount the breaker faceplate on the breaker.

6. For all kits, except the RMS 500 Basic, secure the umbilical wiring harness to the inner surface of the breaker faceplate with 2 of the stick-on wire clamps provided. Also, be sure that the nylon spiral wrap on the umbilical harness covers it where it touches the edge of the breaker faceplate.

7. Install the clear plastic trip unit cover on the breaker faceplate using the 4 sets of thumbscrews, flat washers, and captive fiber washers provided. The fiber washer goes between the plastic cover and the faceplate to hold the thumbscrews captive.

8. Install the Amptector Test Kit warning label 8263A17H01 on the breaker faceplate on a visible location next to the Digitrip RMS terminal strip.

9. Install the Digitrip RMS Retrofit Kit ID label 8187A63H01 on the breaker faceplate on a visible location.

10. Proceed to the circuit breaker checkout and bench test described in Section 11-5 before placing the breaker in service.

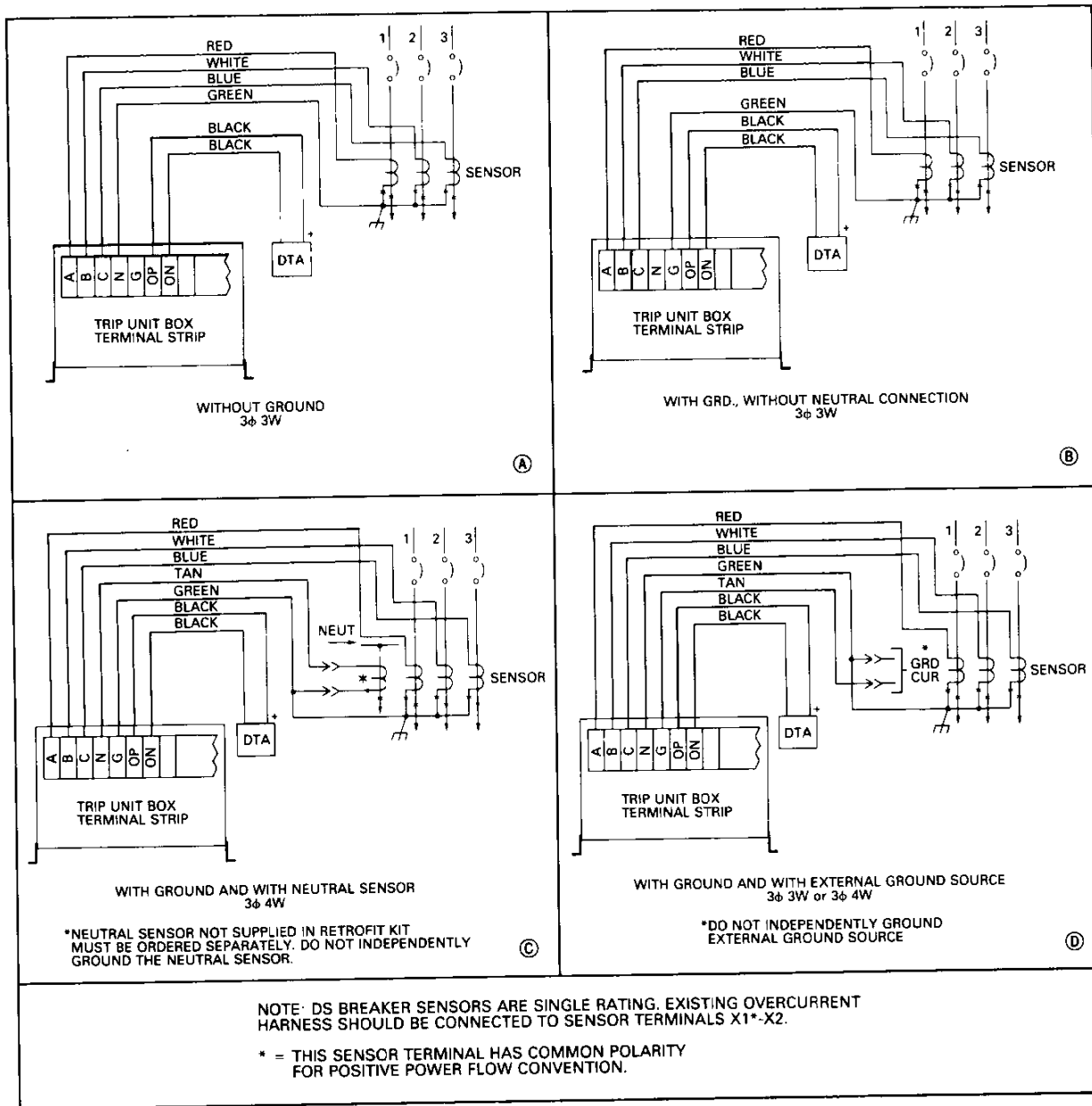

Fig. 9-2. Trip Unit Box Overcurrent Harness and Sensor Connection Diagrams

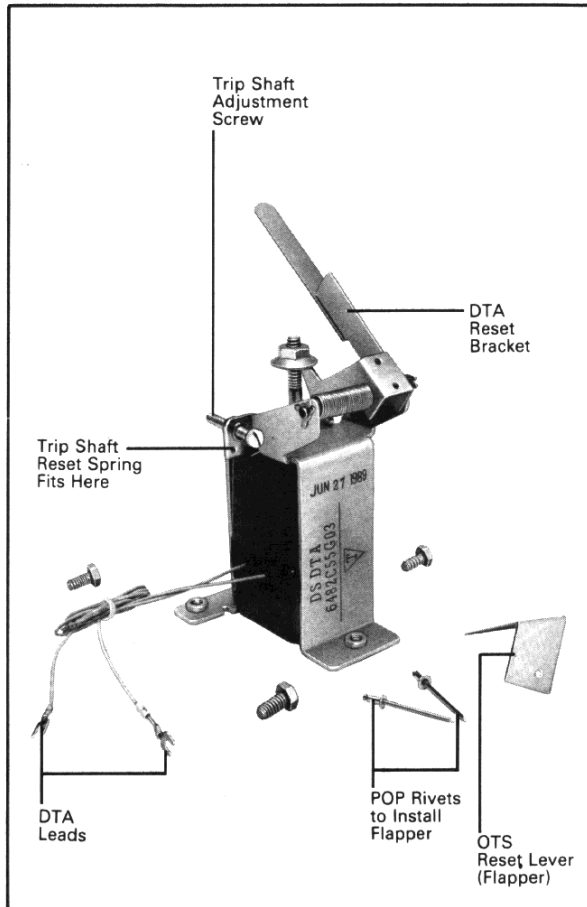

Fig. 9-3. Direct Trip Actuator (DTA)

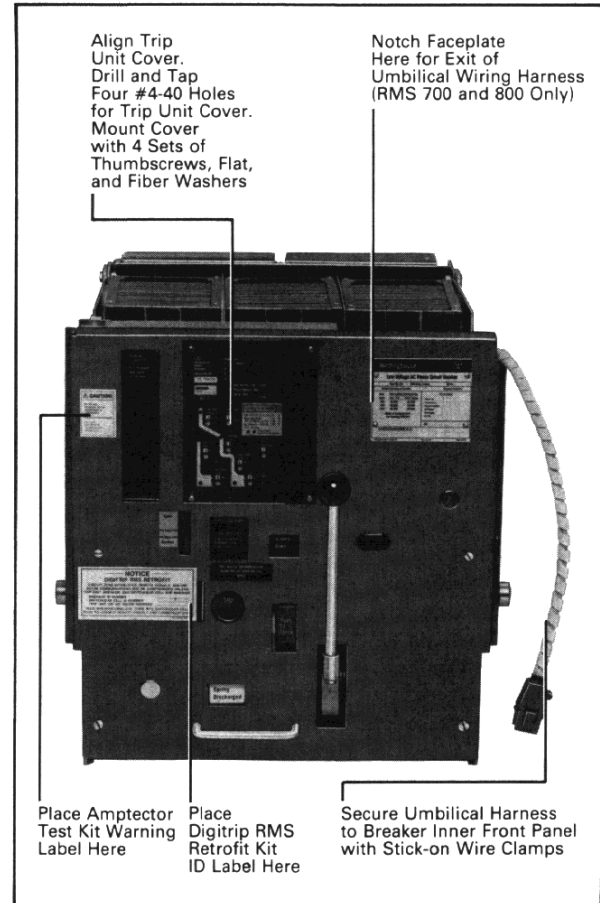
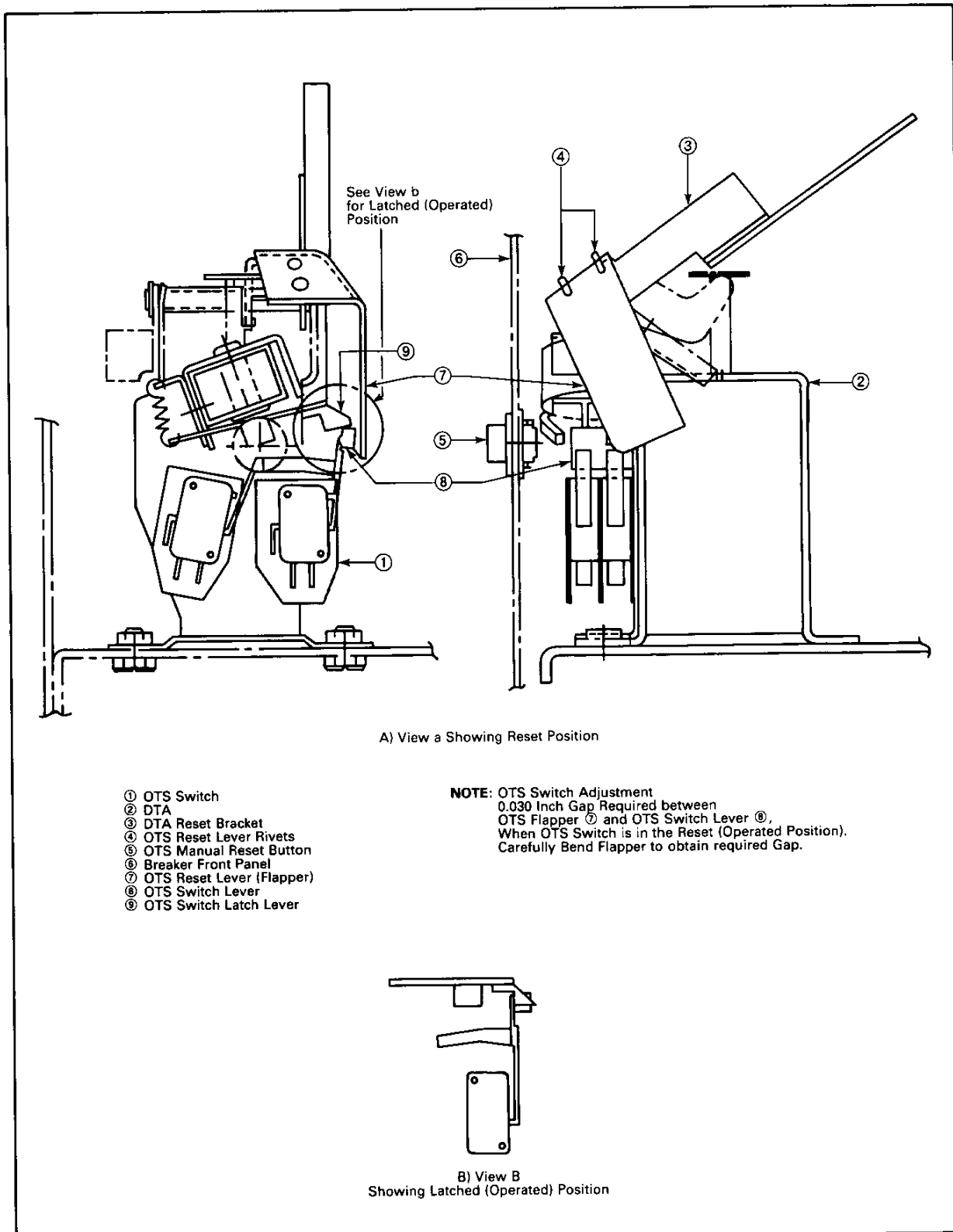

Fig. 9-5. DS Breaker Faceplate Modification



**Fig. 9-4. Overcurrent Trip (OTS) Switch Adjustment**  
(Required for DS Breakers Equipped With OTS Switches Only)

## Section 10

## Switchgear Cell Retrofit Kit Installation

**WARNING**

REFER TO SECTION 1 ENTITLED "GENERAL INFORMATION AND SAFETY PRECAUTIONS" AND REVIEW ALL THE DIRECTIONS SET FORTH IN THAT SECTION, PRIOR TO STARTING THE RETROFIT KIT INSTALLATION. DE-ENERGIZE ALL PRIMARY AND SECONDARY POWER SOURCES TO THE SWITCHGEAR ASSEMBLY, PRIOR TO WORKING ON THE SWITCHGEAR CELL. HAZARDOUS VOLTAGES EXIST IN SWITCHGEAR CELLS AND COULD RESULT IN PERSONAL INJURY, DEATH AND/OR EQUIPMENT DAMAGE.

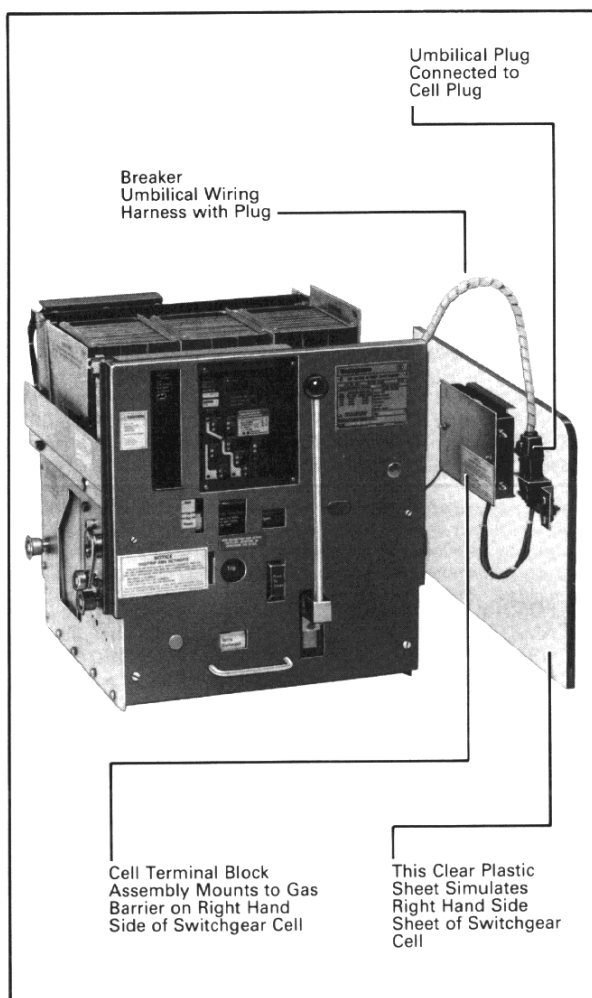

**Fig. 10-1.** DS Breaker Connected to Cell Plug, Wiring Harness, and Terminal Block Assembly (All Kits except RMS 500 Basic)

The following steps identified herein are required to install the retrofit kit components in the switchgear cell. The breaker element must be removed from the switchgear cell and the primary and secondary power sources deenergized.

### 10-1. Cell Terminal Block Assembly Installation (All Retrofit Kits Except the Basic 500 Kit)

1. Refer to Fig. 10-1. This figure simulates a breaker in the cell, plugged into a cell terminal block assembly. Locate the gas barrier on the right hand side of the DS switchgear cell to be retrofitted. Place the terminal block assembly mounting plate against the switchgear cell right hand side sheet, behind the gas barrier, so the two mounting holes center top-to-bottom on the rear of the gas barrier. Mark the hole locations on the gas barrier for drilling.

**Note:** For an alternate method of mounting to the switchgear cell side sheet, two additional mounting holes are located on the terminal block assembly mounting plate. Remove the cover assembly to obtain access to these holes. Mark and drill the side sheet as detailed below.

2. Remove the right hand side gas barrier from the switchgear cell. Center punch the drilling marks and drill two clearance holes using a 0.257 (size F) to 0.266 (size H) drill bit. Install the gas barrier. Mount the terminal block assembly mounting plate with the two sets of 0.25-20 X 0.50 inch hex bolts, lockwashers, flat washers, and hex nuts provided.

### 10-2. Cell Plug and Wiring Harness Installation (All Retrofit Kits Except the Basic 500 Kit)

1. Align the cell plug mounting bracket on the inside metal channel opposite the right hand side gas barrier. Mark and drill two clearance holes (0.257-0.266). Mount the cell plug mounting bracket with the two sets of 0.25-20 X 0.50 inch hex bolts, lockwashers, flat washers, and hex nuts provided.

2. Route the Wiring Harness underneath the gas barrier to suit and dress using the stick-on type wire clamps provided.

### 10-3. Cell Door Label Installation

Install the Digitrip RMS Retrofit Kit ID label 8187A63H01 on the inside of the switchgear cell door on a visible location.

## Section 11

### Testing, Checkout, and Settings

#### WARNING

REFER TO SECTION 1 ENTITLED "GENERAL INFORMATION AND SAFETY PRECAUTIONS" AND REVIEW ALL THE DIRECTIONS SET FORTH IN THAT SECTION, PRIOR TO STARTING THE TESTING AND CHECKOUT PROCEDURES. FAILURE TO FOLLOW SAFE PRACTICES RECOMMENDED IN SECTION 1 COULD RESULT IN PERSONAL INJURY, DEATH AND/OR EQUIPMENT DAMAGE. TESTING AND EQUIPMENT CHECKOUT SHOULD ONLY BE CARRIED OUT BY PERSONNEL FAMILIAR WITH THE HAZARDS ASSOCIATED WITH WORKING ON POWER CIRCUIT BREAKERS AND SWITCHGEAR ASSEMBLIES.

#### 11-1. Dielectric and Meggar Testing

##### CAUTION

TO AVOID POSSIBLE TRIP DAMAGE, PERFORM THE FOLLOWING TWO STEPS BEFORE APPLYING MORE THAN 635 VOLTS TO A BREAKER RETROFITTED WITH A DIGITRIP RMS TRIP SYSTEM:

1. DISCONNECT THE BREAKER UMBILICAL PLUG, WHICH CONNECTS TO THE EXTERNAL BREAKER CELL WIRING. (ALL KITS EXCEPT RMS 500 BASIC MODEL)
2. DISCONNECT POTENTIAL TRANSFORMER MODULE PLUG PTM, WHICH DISCONNECTS THE BREAKER PRIMARY VOLTAGE FROM THE TRIP UNIT. (RMS 700 AND 800 TRIP UNIT MODELS ONLY)

#### 11-2. Testing the Digitrip RMS Trip System

The Digitrip RMS overcurrent trip system may be tested by using one of three possible methods, including The Digitrip Self Test, the Amptector Test Kit, and primary injection testing (e.g. Multi-Amp).

#### WARNING

DO NOT USE THE AMPTECTOR TEST KIT TO TEST DIGITRIP RMS WHILE THE BREAKER IS IN THE "CONNECTED" POSITION IN THE SWITCHGEAR CELL COMPARTMENT.

ALSO, USE OF THE DIGITRIP RMS SELF TEST SYSTEM WHILE THE BREAKER IS IN THE "CONNECTED" POSITION IN THE SWITCHGEAR CELL COMPARTMENT IS NOT RECOMMENDED. THE TRIPPING ACTION OF THE CIRCUIT BREAKER WILL CAUSE DISRUPTION OF SERVICE FROM UNNECESSARY SWITCHING OF CONNECTED EQUIPMENT.

TESTING SHOULD ONLY BE PERFORMED WHEN THE BREAKER IS LEVERED TO THE "TEST", "DISCONNECTED", or "REMOVED" POSITIONS. FAILURE TO COMPLY WITH THESE RECOMMENDATIONS COULD RESULT IN PERSONAL INJURY, DEATH AND/OR EQUIPMENT DAMAGE.

**Note:** Digitrip RMS has a memory circuit that simulates the cool down time required of overloaded conductors. When performing repeated Long Delay Testing, the results may be erroneous as the memory circuit must discharge prior to the next test. The memory circuit can be discharged by disconnecting the power source (APM or 120 Vac input) to the trip unit between tests or by waiting several minutes between tests.

#### 11-3. Digitrip RMS Self Testing

The Digitrip RMS Self-Testing System requires one of two external power sources (discussed below) to operate. Detailed instructions for Digitrip RMS Self-Testing are provided in the appropriate Digitrip RMS Trip Unit Instruction Leaflet identified in the REFERENCES section of this document.

##### 1. Auxiliary Power Module

The Auxiliary Power Module (APM), Catalog Number PRTAAPM, is an optional accessory item used to power the Digitrip RMS Trip Unit Self-Testing System. The APM is plugged into the Digitrip Trip Unit test port and connected to a 120 Vac 50/60 Hz circuit. The Digitrip RMS Self-Test System is then enabled by pressing the "TEST" pushbutton.

##### 2. External 120 Vac Source to Power/Relay Module

Digitrip RMS Models 600, 700, and 800 Trip Units are equipped with an Power/Relay Module (ATR). The ATR has input provisions for an external 120 Vac source. When 120 Vac power is supplied to Digitrip RMS through the cell terminal block terminals "AC120" and "ACCOM," the 120 Vac power can be brought to the ATR by plugging in the breaker umbilical harness. The Digitrip RMS Self Test System is then enabled by pressing the "TEST" pushbutton.

#### 11-4. Amptector Test Kit

##### CAUTION

POSSIBLE DAMAGE TO TRIP UNIT DO NOT USE AMPTECTOR TEST KIT STYLES 140D481G01 OR G02 USE AMPTECTOR TEST KIT STYLES 140D481G02R, 140D481G02RR, OR 140D481G03 ONLY

Digitrip RMS Trip Units may be tested over a partial range using either style 140D481G02RR or 140D481G03 Amptector Test Kit as shown in Fig. 11-1. For additional instructions on testing Digitrip RMS with the Amptector test kit see the REFERENCES section of this document.

When testing Digitrip RMS with the Amptector Test Kit, an external power source to the trip unit is required. Use either the Auxiliary Power Module (APM) or the 120 Vac input to the Power/Relay Module (Models 600, 700, or 800 only) as discussed above.

**Note:** The Amptector Test Kit produces a maximum of 40 to 48 amperes when connected to Digitrip RMS. Test kit outputs are limited to 8-9 times the Rating Plug-in rating. This restricts the test range for Short Delay and Instantaneous Testing.



### 11-5. Primary Injection Testing

Primary injection testing is a useful alternative to the secondary injection methods described above. Primary injection is the true test method to verify the complete breaker overcurrent protection system including the current sensors, rating plug, and the trip unit. It involves the use of a tester, e.g. Multi-Amp Tester, to inject single phase primary current through the breaker to test the Digitrip RMS overcurrent trip system.

#### Notes on Testing

- When performing primary injection testing on breakers equipped with Ground Fault (G) protection, Trip Box Terminals G and N can be shorted together with a suitable jumper to temporarily defeat the ground fault trip function. This will enable the breaker to be tested in the Long Delay portion of the curve without tripping on ground fault. The jumper must be removed after testing to reinstate the ground fault protection on the breaker.
- When performing primary injection testing on breakers with current limiters, the current limiters should be removed and replaced with copper shorting bars prior to testing. Failure to do so could result in compromising the expected performance of the current limiters. The shorting bars must be removed and the current limiters reinstalled after testing is completed.

### 11-6. Circuit Breaker Checkout and Bench Test

Before the breaker is returned to the switchgear for placement into service, the retrofit kit installation must be checked out and tested. Check all breaker retrofit wiring paths to be sure that they are properly routed and free from potential interference with breaker moving parts. Confirm all wiring harness terminations are secure.

Perform several breaker manual close and overcurrent trip operations. This test can be performed using any of the above described test methods. An effective installation checkout and test procedure should include the following:

1. Select and set the proper user-determined overcurrent trip settings for the Digitrip RMS Trip Unit. Verify the trip unit is in calibration by selecting and testing several trip points (as applicable) on the Long Delay, Short Delay, Instantaneous, and Ground Fault Time portions of the Digitrip RMS trip curve. Record the trip unit settings for permanent record and future reference.

#### Notes on Testing

- Due to the Digitrip RMS Zone Interlocking functions, the Short Delay and Ground Fault Time trip functions will trip instantaneously, unless Digitrip RMS Terminal SIN is shorted to SOUT and GIN to GOUT.
  - Digitrip RMS has a memory circuit that simulates the time required to cool down of overloaded conductors. When performing repeated Long Delay Testing, the results may be erroneous as the memory circuit must discharge prior to the next test. The memory circuit can be discharged by disconnecting the power source (APM or 120 Vac input) to the trip unit between tests or by waiting several minutes between tests.
2. Verify the DTA properly resets. The breaker will not close unless the DTA resets.

3. For breakers equipped with OTS Switches, confirm the proper operation of the OTS switch. When the breaker trips on an overcurrent condition, the OTS switch must latch and its contacts change state. If not, adjust the OTS switch as detailed in OTS SWITCH ADJUSTMENT PROCEDURE. Manually reset the OTS switch after each trip through the pushbutton on the breaker faceplate or electrically, if applicable, by energizing the OTS reset coil.

Before returning the breaker to the switchgear after the breaker bench testing has been completed, lever the breaker element levering mechanism from the "TEST" position to the "DISCONNECT" position. Confirm the breaker position indicator reads "OPEN" and the spring charged indicator reads "DISCHARGED".

### 11-7. Setting Digitrip RMS INCOM Address (Digitrip RMS Models 700 and 800 Only)

#### NOTICE

SETTING DIGITRIP RMS INCOM ADDRESS PROVIDES THE TRIP UNIT A UNIQUE IDENTIFICATION FOR COMMUNICATIONS. INCOM COMMUNICATIONS MAY BE COMPROMISED UNLESS TRIP UNIT, BREAKER, AND SWITCHGEAR CELL ARE MATCHED

Each Digitrip RMS Model 700 and 800 Trip Unit has a three dip switches that must be set to provide the trip unit with a unique address for INCOM Communications. The rating plug must be removed from the trip unit to obtain access to the dip switches. Each dip switch can be set with a small blade screwdriver from 0-9. The three switches have a sequence convention of top to bottom for a left to right address.

### 11-8. Identification of Trip Unit, Breaker, and Switchgear Cell

Your Digitrip RMS Retrofit Kit includes identification labels for the Digitrip RMS Trip Unit, the breaker element faceplate, and the inside of the switchgear cell door. It is important to identify all three, especially when the trip unit has an INCOM address (Models 700 and 800 only). The labels for the breaker faceplate and the cell door are as follows:

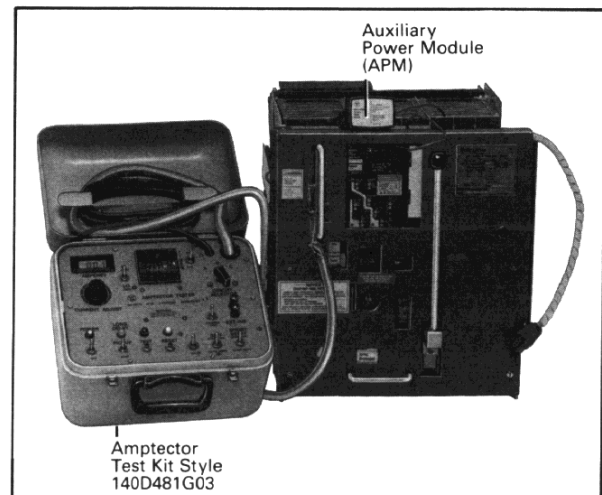

Fig. 11-1. DS Breaker Testing With 140D481G03 Amptector Test Kit and Auxiliary Power Module (APM)

## Section 12

### Operation

#### WARNING

REFER TO SECTION 1 ENTITLED "GENERAL INFORMATION AND SAFETY PRECAUTIONS" AND REVIEW ALL THE DIRECTIONS SET FORTH IN THAT SECTION, PRIOR TO OPERATING THE EQUIPMENT. FAILURE TO FOLLOW SAFE PRACTICES RECOMMENDED IN SECTION 1 COULD RESULT IN PERSONAL INJURY, DEATH AND/OR EQUIPMENT DAMAGE. OPERATION OF THE EQUIPMENT SHOULD ONLY BE CARRIED OUT BY PERSONNEL FAMILIAR WITH THE HAZARDS ASSOCIATED WITH WORKING ON POWER CIRCUIT BREAKERS AND SWITCHGEAR ASSEMBLIES.

The information presented for the operation of Digitrip RMS Retrofitted power circuit breakers and switchgear supplements the content of the original equipment instruction manuals. Further, the information described supplements any established procedures in practice at the customer location.

#### WARNING

BREAKER AND SWITCHGEAR CELL RETROFIT INSTALLATIONS MUST BE CHECKED AND TESTED PRIOR TO PLACING THE EQUIPMENT IN OPERATION. SECTION 11 PROVIDES INFORMATION ON RECOMMENDED TESTING AND CHECK-OUT PROCEDURES. FAILURE TO FOLLOW THESE PROCEDURES COULD RESULT IN PERSONAL INJURY, DEATH AND/OR EQUIPMENT DAMAGE.

#### 12-1. Breaker Insertion in Switchgear Cell and Power Up

#### WARNING

PRIOR TO INSERTING THE BREAKER INTO THE CELL, BE SURE THE BREAKER IS IN THE OPEN POSITION AND THE TRIP UNIT ADJUSTABLE SETTINGS ARE CORRECT. ADDITIONALLY, BE SURE THE TRIP UNIT, BREAKER AND SWITCHGEAR CELL MATCH, AS DESCRIBED IN SECTION 11-8. FAILURE TO DO SO COULD RESULT IN PERSONAL INJURY, DEATH AND/OR EQUIPMENT DAMAGE.

Rack the breaker to the CONNECT position in the switchgear cell. RMS 500 Basic retrofitted breakers include no umbilical harness and are ready to be closed. For RMS 500 Zone, 600, 700, and 800 retrofitted breakers, plug the umbilical harness into the cell terminal block, wiring harness, and plug assembly as shown in Fig. 10-1, and then close the breaker. The umbilical harness connects the external trip unit signals. For RMS 600, 700, and 800 retrofitted breakers, the trip unit green Status LED will begin to blink when the plug is connected, indicating the trip unit is operational and the 120 Vac external source is on. For RMS 500 Basic and RMS 500 Zone retrofitted breakers, the trip unit green Status LED will begin to blink when the breaker is closed and primary current begins to flow.

#### NOTICE

Digitrip RMS overcurrent protection is maintained, even when the breaker umbilical harness plug is not plugged into the cell plug. The Digitrip RMS overcurrent trip system is integrally powered by the primary phase currents passing through the current sensors.

#### 12-2. Information Available to Operator While Breaker is in Service

Fig. 12-2 lists the available information provided by Digitrip RMS Trip Units while the breaker is in service.

#### 12-3. Information Available in the Event of a Trip

In the event of a trip, the Digitrip RMS Trip Unit provides information as summarized in Fig. 12-2 for operator use.

#### 12-4. Resetting the Trip Unit After a Trip

Following an overcurrent trip, the trip unit should be reset by depressing the TRIP RESET pushbutton, before the breaker is closed.

The RMS 500 retrofit trip unit mode of trip LEDs are powered by the rating plug battery. The breaker can be closed without resetting the trip unit, however the LED will remain lit until the trip unit TRIP RESET pushbutton is depressed. Resetting the trip unit in a timely manner saves on battery life. In new condition the battery will power the LED for approximately 60 hours.

The RMS 600, 700, and 800 retrofits have provisions for an external 120 Vac source connected through the umbilical harness. If the 120 Vac source is on, the breaker will be held in the trip free condition (cannot be closed) by the Direct Trip Actuator (DTA) until the trip unit TRIP RESET pushbutton is depressed. The trip unit mode of trip LEDs are powered by an external 120 Vac source, and backed up by the battery in the rating plug. If the external 120 Vac source to the trip unit is lost, the trip unit acts as described for the RMS 500.

The RMS 700 and 800 retrofits have communications capability, which permit opening and (for electrically operated breakers) closing via INCOM. In the event of an overcurrent trip, the trip unit will act as described, requiring local resetting of the trip unit before the breaker can be closed. However, if the breaker is tripped remotely via INCOM (alphanumeric coded message EXTT), it can be closed via INCOM without local resetting at the trip unit.

#### 12-5. Removing the Breaker from the CONNECT Position

RMS 500 Basic retrofitted breakers include no umbilical harness and require no special procedures (other than those normally observed) for removing the breaker from the CONNECT position in the switchgear cell.

RMS 500 Zone, 600, 700, and 800 Retrofitted are equipped with the umbilical harness. Care must be observed to disconnect the umbilical harness plug from the switchgear cell terminal block, wiring harness, and plug assembly, when removing the breaker from the CONNECT position.

**Note:** If the cell terminal block, wiring harness, and plug assembly is properly positioned in the switchgear cell with respect to the breaker, the breaker can be withdrawn to the TEST position with the umbilical harness plugged in. However, to withdraw the breaker completely from the cell, the umbilical wiring harness must be disconnected.

**CAUTION**

FAILURE TO DISCONNECT THE UMBILICAL WIRING HARNESS FROM THE CELL TERMINAL BLOCK, WIRING HARNESS, AND PLUG ASSEMBLY IN THE SWITCHGEAR CELL COULD CAUSE PHYSICAL DAMAGE TO THE EQUIPMENT.

## Section 13

Digitrip RMS Retrofit Kit  
Switchgear Assembly Applications**WARNING**

REFER TO SECTION 1 ENTITLED "GENERAL INFORMATION AND SAFETY PRECAUTIONS" AND REVIEW ALL THE DIRECTIONS SET FORTH IN THAT SECTION, PRIOR TO WORKING WITH THE EQUIPMENT. FAILURE TO FOLLOW SAFE PRACTICES RECOMMENDED IN SECTION 1 COULD RESULT IN PERSONAL INJURY, DEATH AND/OR EQUIPMENT DAMAGE. OPERATION OF THE EQUIPMENT SHOULD ONLY BE CARRIED OUT BY PERSONNEL FAMILIAR WITH THE HAZARDS ASSOCIATED WITH WORKING ON POWER CIRCUIT BREAKERS AND SWITCHGEAR ASSEMBLIES.

**13-1. Zone Interlocking**

All Digitrip RMS Trip Units include provisions for zone interlock connection of the trip unit short time (S) and ground fault (G) delay protective functions. If zone interlocking is not required, it must be defeated by shorting out the appropriate terminals.

**NOTICE**

Digitrip RMS Zone Interlocking will trip the breaker instantaneously on short time (S) or ground fault (G) delay trip functions unless it is defeated as described herein.

For RMS 500 Basic Retrofit Kits, zone interlock functions are not wired out from the trip unit. Zone interlocking is defeated by the zone interlock shorting clips installed at trip unit box as shown in Fig. 4-3.

For RMS 500 Zone, 600, 700, and 800 Retrofit Kits, zone interlock functions are extracted from trip unit box by the breaker umbilical wiring harness as shown in Fig. 5-3. The breaker umbilical wiring harness plugs into the cell plug, wiring harness, and terminal block assembly. The terminal block assembly includes provisions for external wiring connections as shown in Fig. 5-4. Shorting jumpers (SIN-SOUT and GIN-GOUT) are provided at the terminal block assembly to defeat the zone interlock functions. These jumpers can be removed and selective zone interlocking schemes applied. Typical connection schemes for multiple breaker circuit breakers are shown in Figs. 13-1 and 13-2.

**13-2. The Power Relay Module (ATR)**

RMS 600, 700, and 800 Retrofit Kits include the power relay module (ATR), which is mounted integral to the trip unit box. The ATR input and output signals are extracted from the trip unit through the umbilical wiring harness as shown in Fig. 6-3. The breaker umbilical wiring harness plugs to the cell plug, wiring harness, and terminal block assembly, which includes provisions for external wiring connections as shown in Fig. 6-4. Fig. 13-3 shows typical ATR 120 Vac source input and dry contact alarm output connections for remote alarm indication.

**NOTICE**

ATR contacts are rated 1 amp at 120 Vac or 24 Vdc. Control Voltages and currents that exceed these values will require the use of an external interposing relay.

RMS 700 and 800 Retrofit Kits also include an operational contact across ATR terminals CC1 and CC2 for use in remote closing of electrically operated breakers via communications. When a close command is initiated by the communications system, the CC1-CC2 contact will close for approximately 1 second. See Fig. 13-7 for a typical application.

**13-3. Communications and INCOM**

RMS 700 and 800 Retrofit Kits include communications capability when used with the Westinghouse Integrated Monitoring Protection and Control Communications (IMPACC) System. Each RMS/R trip unit includes an Integrated Communications (INCOM) Chip that permits the extraction of trip unit data and the implementation of breaker close and trip commands from a remote master computer. Communications is accomplished from the trip unit to the master computer via radio frequency signal over a twisted pair communications network. The communication signals (COMM1 and COMM2) are extracted from trip unit through the umbilical wiring harness as shown in Fig. 7-4. The breaker umbilical wiring harness plugs to the cell plug, wiring harness, and terminal block assembly, which includes provisions for external wiring connections as shown in Fig. 7-5.

Typical INCOM network communication schemes are shown in Fig. 13-4 through 13-6. For a simple pre-engineered network system, the following rules apply:

**Rule 1:**

Up to 5 "main runs" may be connected to the system master computer. Each run may be a maximum of 7500 feet in length to the farthest addressable device.

**Rule 2:**

A 150 ohm, 0.50 watt "end-of-line" resistor must be placed at the end of each main run at the farthest addressable device. This resistor properly balances the network impedance to reduce the potential for standing waves.

**Rule 3:**

An unlimited number of "tees" (maximum length 200 feet) can be added to each "main run". No "end-of-line" resistor is required at the end of the "tee". "Tees" must be connected in parallel to the "main run".

**Rule 4:**

If a "main run" or "tee" terminates at its end to an Assemblies Electronic Monitor (AEM) equipped with a Time Stamp Filter (TSF), the communications network can be extended another 7500 feet. The AEM can accommodate a maximum of 40 Digitrip RMS 700 or 800 Trip Units and 8 IQ Data Plus II devices. An "end-of-line" resistor is required at the farthest device on the extended line.

**Rule 5:**

Use of #18 AWG shielded cable is recommended where EMF interference of INCOM with other circuits is possible. The cable shielding serves to prevent the INCOM signals from such interference.

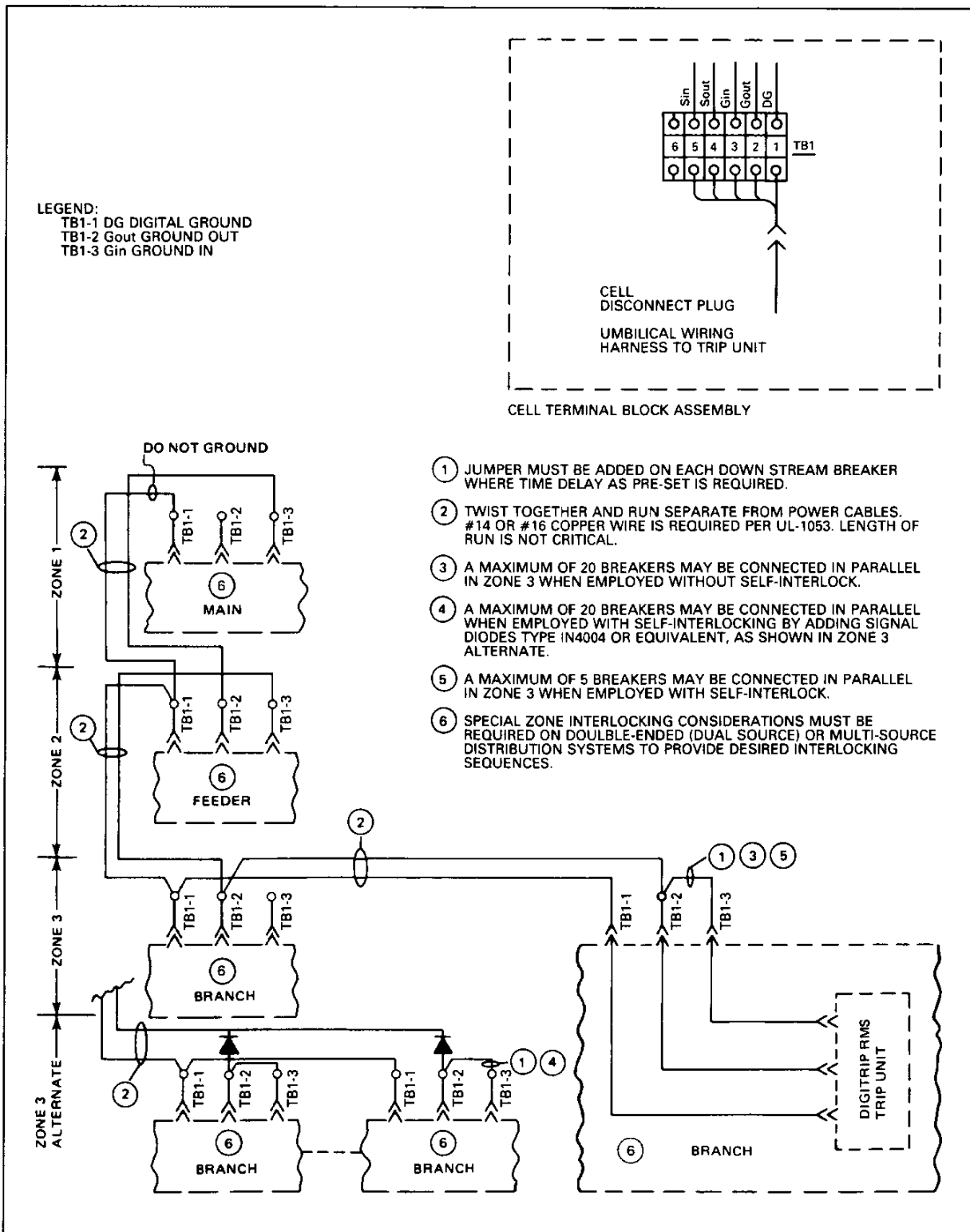

Fig. 13-1. Typical Ground Fault Zone Interlocking Connections for Radial Distribution Systems

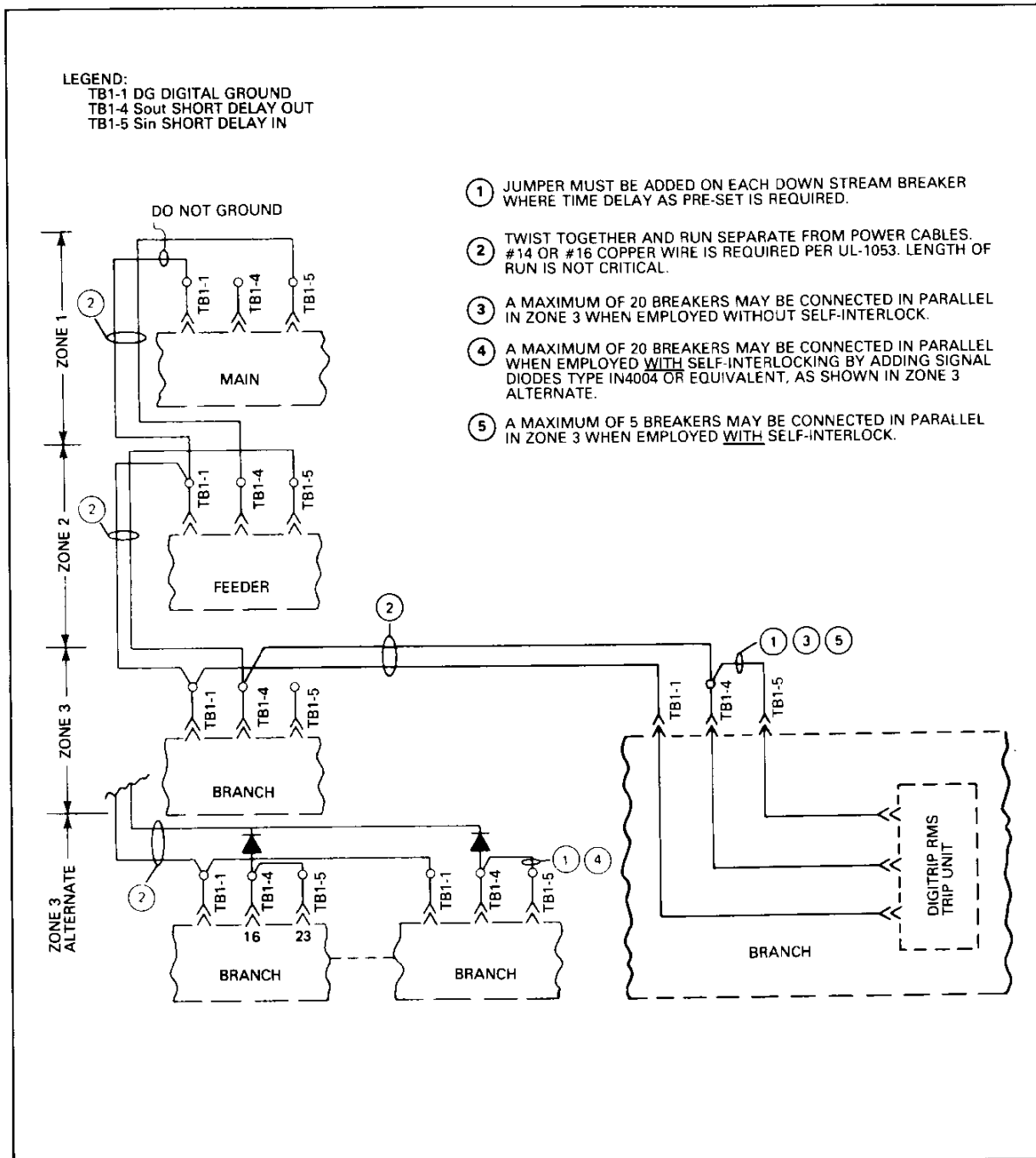

Fig. 13-2. Typical Short Delay Zone Interlocking Connections for Radial Distribution Systems

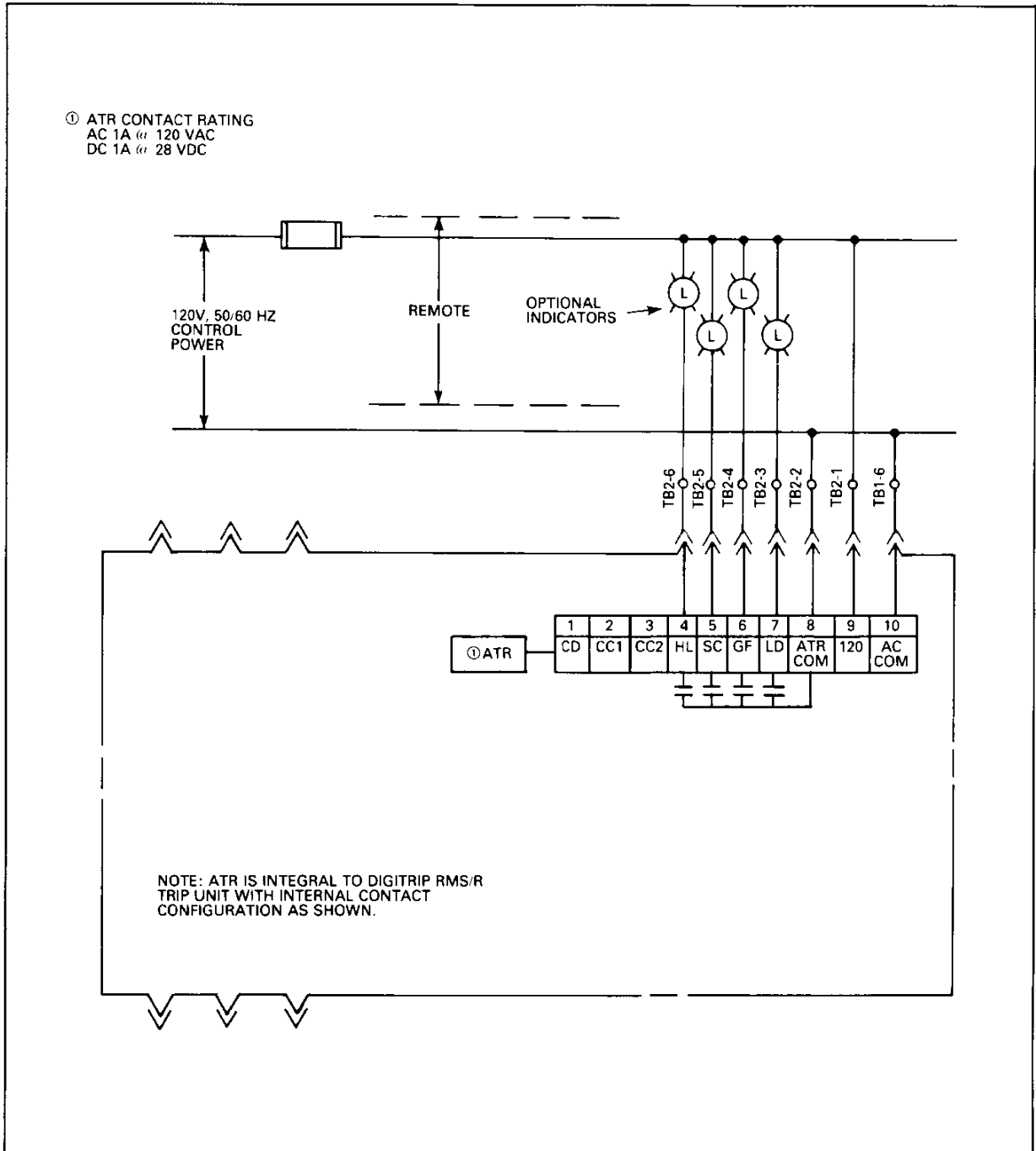

Fig. 13-3. Typical Remote ATR Alarm Connections for Use With Digitrip RMS 600, 700, and 800 Retrofit Kits

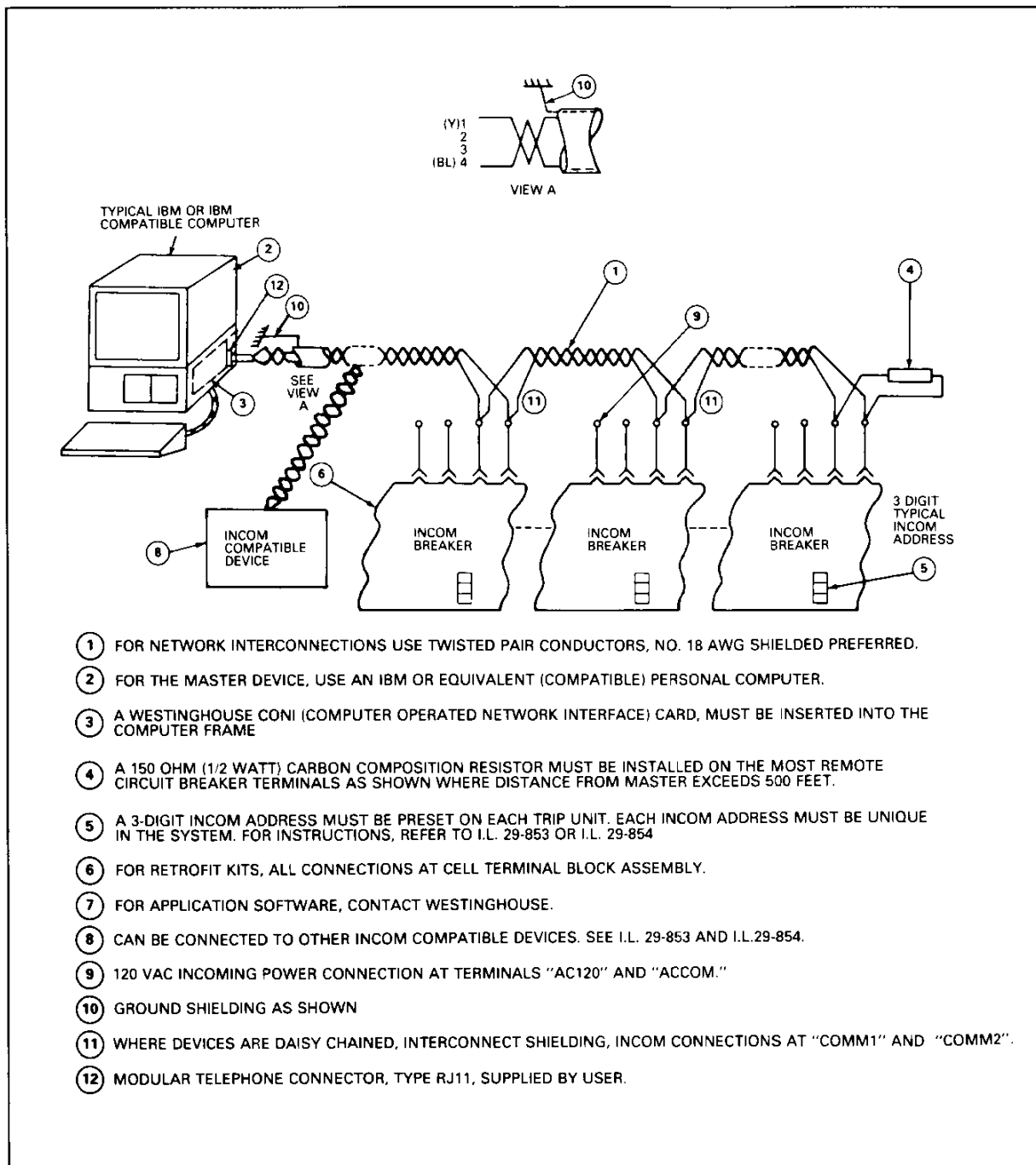

Fig. 13-4. Typical INCOM Network Interconnections With Master Computer for Use With Digtrip RMS 700 and 800 Retrofit Kits



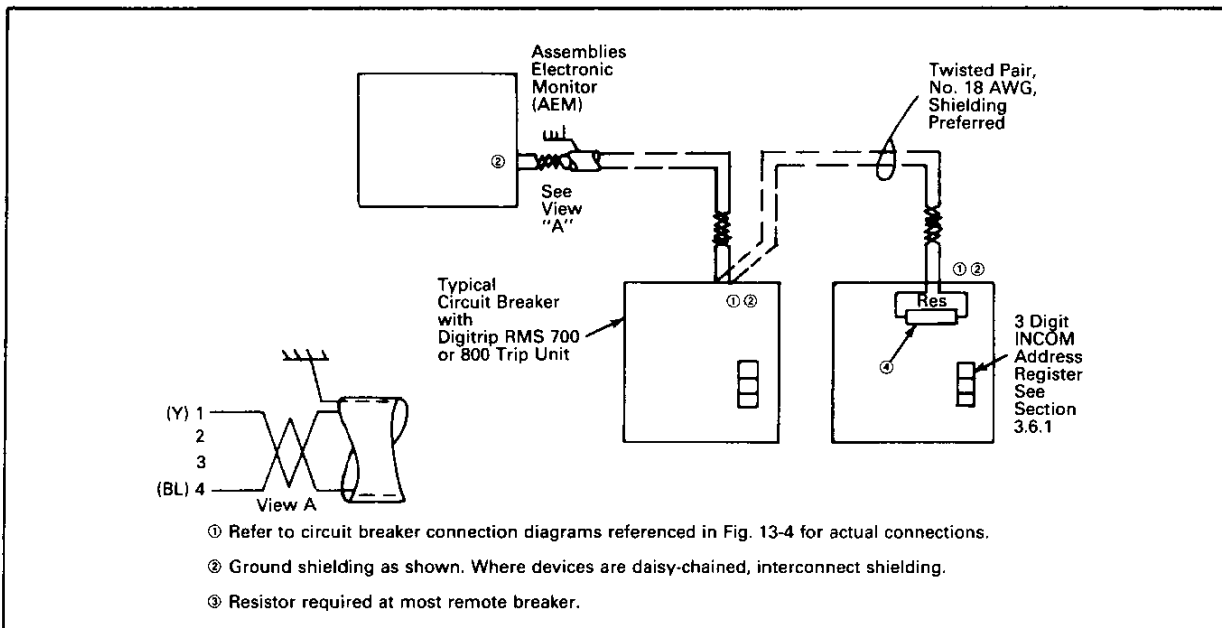

Fig. 13-5. Typical INCOM Network Interconnections with Assemblies Electronic Monitor

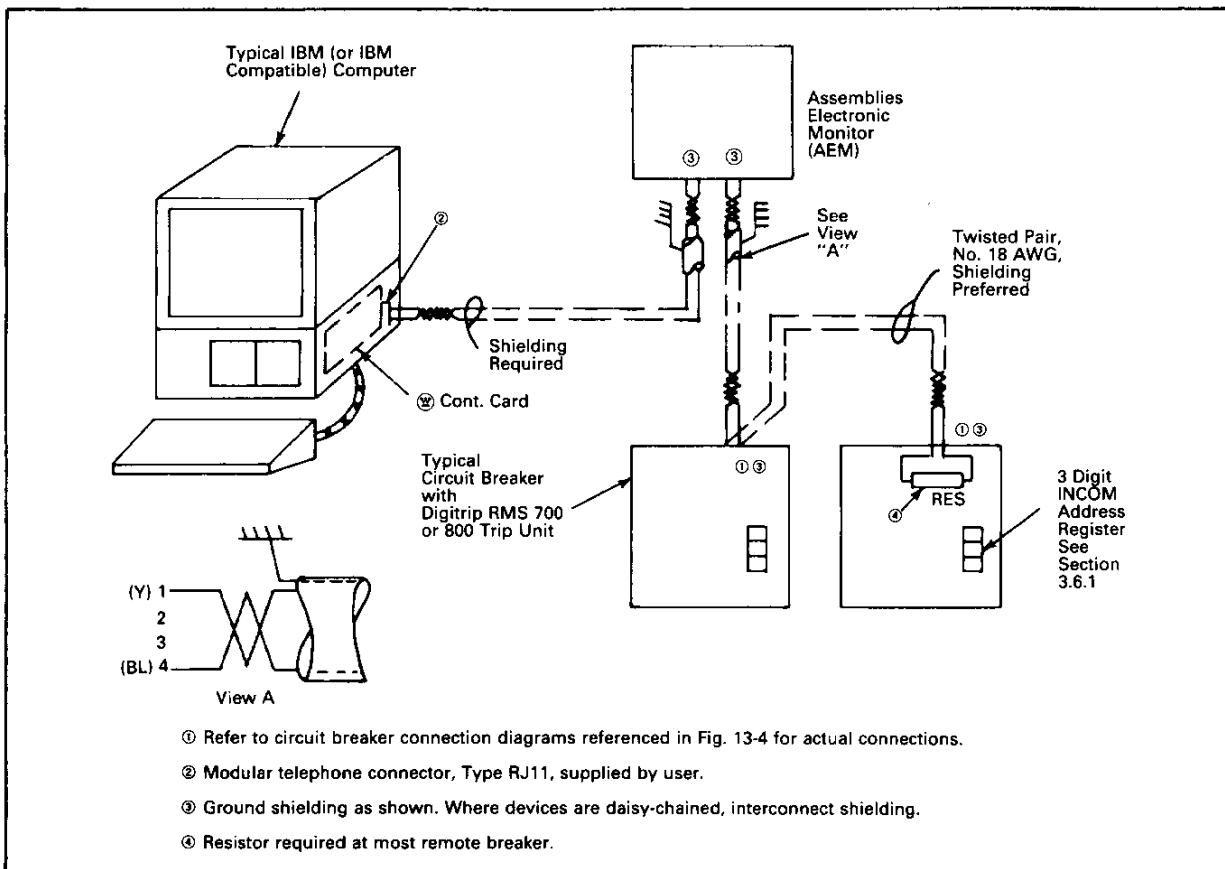

Fig. 13-6. Typical INCOM Network Interconnections with Remote Computer and Assemblies Electronic Monitor

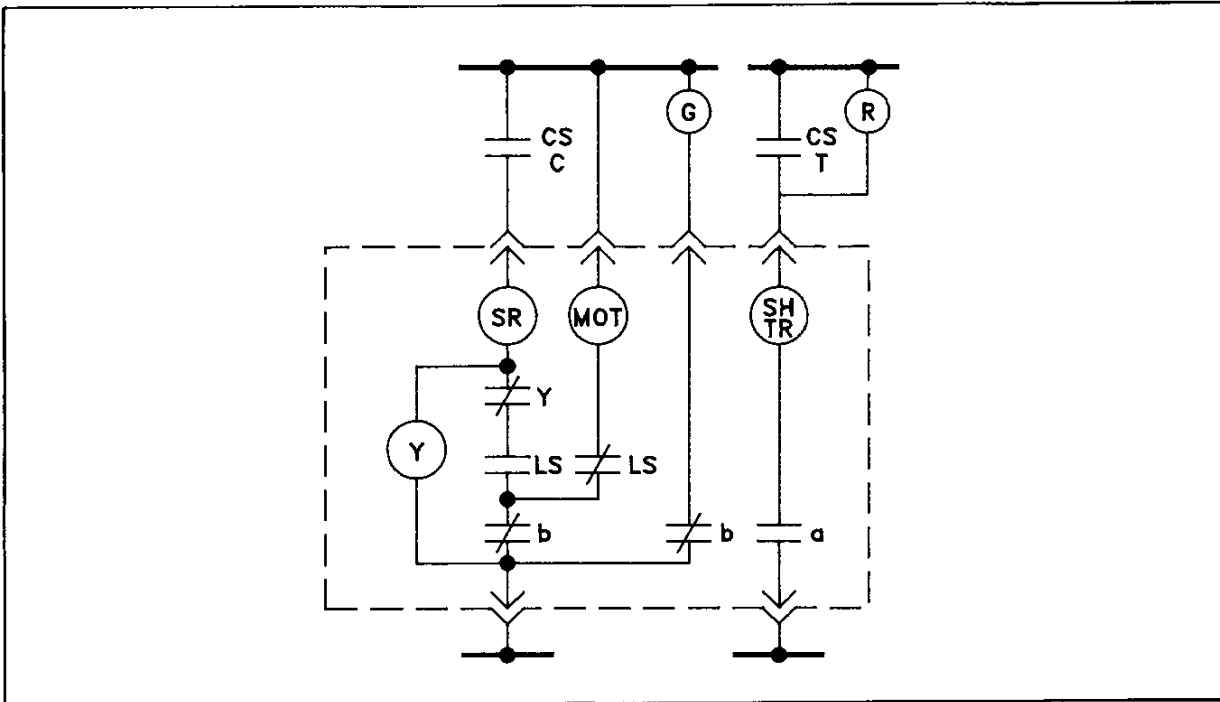

Fig. 13-7. (A) Typical Breaker Control Schematic

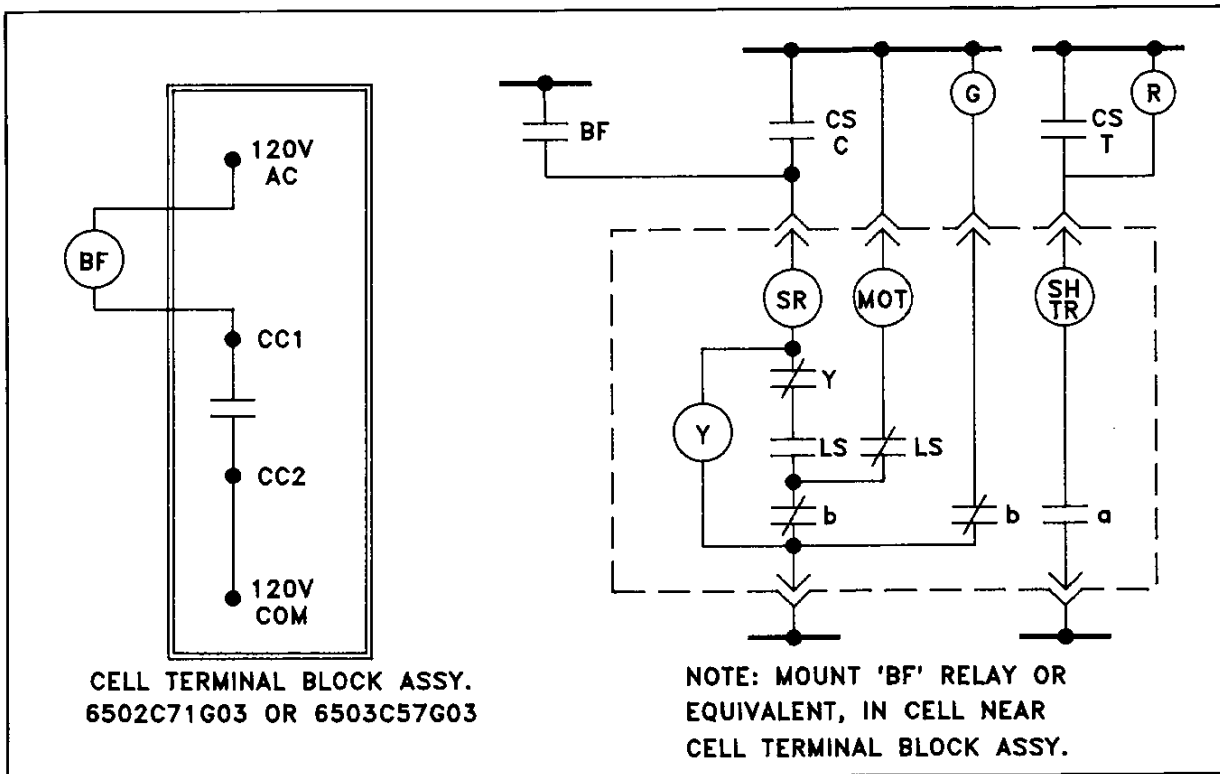

Fig. 13-7. (B) Control Schematic with CC1/CC2 and Interposing Relay.

## Section 14

### Warranty and Service Information

#### WARNING

REFER TO SECTION 1 ENTITLED "GENERAL INFORMATION AND SAFETY PRECAUTIONS" AND REVIEW ALL THE DIRECTIONS SET FORTH IN THAT SECTION, PRIOR TO WORKING WITH OR PERFORMING PREVENTATIVE MAINTENANCE ON THE EQUIPMENT. FAILURE TO FOLLOW SAFE PRACTICES RECOMMENDED IN SECTION 1, OR FAILURE TO PROPERLY MAINTAIN THE EQUIPMENT, AS OUTLINED IN THIS SECTION, COULD RESULT IN PERSONAL INJURY, DEATH, EQUIPMENT DAMAGE AND/OR VOIDING OF THE WARRANTY.

The contents of this section provide important information on the retrofitted power circuit breaker maintenance, warranty, and service.

#### 14-1. Preventative Maintenance Program

Establishment of a periodic preventative maintenance program is essential to assure breaker and switchgear reliability and integrity. Periodic maintenance, including testing, inspection, adjustment, and repair should be performed on the both the circuit breaker and the switchgear assembly. For normal operating conditions, a minimum periodic interval of 12 months is recommended. However, additional factors, such as equipment age, state of repair, general condition, local operating environment, number of annual cycles, etc. must be considered in determining an effective maintenance interval.

#### 14-2. Breaker Maintenance

Installation of a Digitrip RMS Retrofit Kit on an existing circuit breaker does not alleviate the user from maintaining the circuit breaker in good operating condition. The Digitrip RMS Trip System will greatly enhance the capability of the circuit breaker to reliably and accurately detect and initiate a trip in the event of an overcurrent condition or fault. However, the ability of the breaker to trip and clear the fault is directly dependent on the operating condition of the breaker.

The user should continue to follow the applicable instructions and procedures provided by the breaker manufacturer and incorporate them into a periodic preventative maintenance program. The following items are not all inclusive, but should be an integral part of such a program:

1. **Cleanliness:** Breaker moving parts, insulation, and current carrying parts should be kept clean from dust, dirt, and sludge.
2. **Lubrication:** The breaker operating mechanism should open (trip) and close properly and not stick, bind, or jam. The breaker should be lubricated as required according to the manufacturers recommendations.
3. **Contact Condition and Adjustment:** Breaker moving and stationary arcing and main contacts should be in proper adjustment, in good condition, and free from burning and pitting. Breaker primary and secondary disconnecting contacts should be in good condition.
4. **General Condition and Repair:** Breaker hardware should be tight and retaining rings in tact. Worn out parts should be replaced or repaired. Electrical connections and wire insulation should be sound and free from evidence of overheating.
5. **Digitrip RMS Trip System:** Section 10 provides recommended testing procedures for the Digitrip RMS Trip System.

#### 14-3. Warranty Procedure

Digitrip RMS Retrofit Kits include a limited warranty for components for 1 year from the date of shipment. In the event of a warranty problem with a retrofit kit component, contact Westinghouse by the channel through which the retrofit kit was purchased. Contact the Westinghouse retrofit kit distributor, representative, or installer (as applicable) and provide the following information:

1. Original order number by which the kit component was purchased.
2. Part description.
3. Part catalog and/or style number.
4. Complete description of the problem.

If the problem is covered under warranty, instructions will be provided for obtaining a component replacement or for returning the component for repair.

#### 14-4. Digitrip RMS Trip Unit Warranty

Digitrip RMS Trip Units are factory sealed and are not field serviceable. Breaking the factory seal, opening the trip unit, and tampering with it's internal components will void any warranty. In the event of a problem with the trip unit, contact your local Westinghouse representative per the instructions provided in section 14-2 above.

## Section 15

### References

The listed documents are available references applicable to your Digitrip RMS Retrofit Kit Installation on DS Breakers.

I.B. 33-790-1G  
Instructions for Low Voltage Power Circuit Breakers Types DS and DSL.

I.B. 33-790-1G  
Supplement A  
Instructions for Low Voltage Power Circuit Breakers Types DS and DSL.

A.D. 32-860A  
Characteristic Curves for Types DS and DSL Circuit Breakers With Digitrip RMS 500/600/700/800 Trip Units, includes curves:

SC-4280-87 Typical Time-Current Characteristic Curve (Long Time/Instantaneous Time) for DS Breakers.

SC-4281-87 Typical Time-Current Characteristic Curve (Long Time/Short Time) for DS Breakers.

SC-4282-87 Typical Time-Current Characteristic Curve (Ground Fault Protection) for DS Breakers.

I.L. 29-851	Instructions for Digitrip RMS 500 Trip Units
I.L. 29-852	Instructions for Digitrip RMS 600 Trip Units
I.L. 29-853	Instructions for Digitrip RMS 700 Trip Units
I.L. 29-854	Instructions for Digitrip RMS 800 Trip Units

I.B. 33-pending  
Instructions for Use of Amptector Test Kit on Digitrip RMS Trip Units.

RPD 33-790-1G  
Renewal Parts Data Low-Voltage Power Circuit breakers and Cell Parts Types DS and DSL.

## Free Manuals Download Website

<http://myh66.com>

<http://usermanuals.us>

<http://www.somanuals.com>

<http://www.4manuals.cc>

<http://www.manual-lib.com>

<http://www.404manual.com>

<http://www.luxmanual.com>

<http://aubethermostatmanual.com>

Golf course search by state

<http://golfingnear.com>

Email search by domain

<http://emailbydomain.com>

Auto manuals search

<http://auto.somanuals.com>

TV manuals search

<http://tv.somanuals.com>