

September, 1984  
New Information

## Robonic II Automatic Transfer Switches Operation and Maintenance Manual

# ROBONIC II

## AUTOMATIC TRANSFER SWITCH

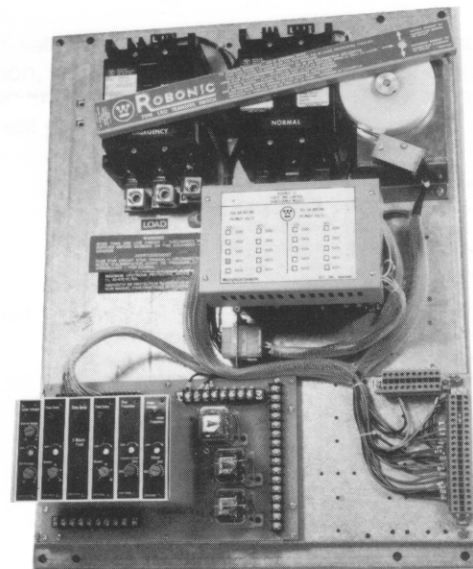

### Index

Warranty .....	2
Westinghouse Offices .....	3
General Description .....	4
Component Identification .....	7
LRO Description .....	5
RO Description .....	6
PRO Description .....	6
Application Information .....	7
Logic Control .....	7
Replacing Parts .....	13
Trouble Shooting Guide .....	14
Recommended Maintenance .....	14

#### Warranty

The company warrants the apparatus to be supplied hereunder to be of the kind designated or specified. The company shall repair or replace any defective part or parts, f.o.b. the company's factory, repair shop or warehouse, which prove to be defective under normal and proper use within one year from the date of shipment, provided that the purchaser gives the Company immediate written notice of any such defect or defects. In no event (including, but not limited to the negligence of the Company, it's employees or agents) shall the Company be liable for special or consequential damages or damages for loss of use and on expiration of the Warranty period, any liability of the Company shall terminate. This constitutes the only warranty of the Company and no other warranty or condition, statutory or otherwise, shall be implied.

#### **IMPORTANT**

**Check equipment for shipping damage immediately on receipt. In case of damage call the carriers concerned at once for inspection, and request an inspection report. Do not write to us first - notify the carrier instead. If this precaution is not taken we cannot assist you in recovering the amount of the claim against the carrier.**

## For Supply

Westinghouse industrial products, and a complete line of electrical construction products, are distributed across Canada by WESCO (Westinghouse Sales & Distribution Company). For product application, delivery or pricing information, call the WESCO office nearest you.

### WESCO Sales Office

St. John's	726-9073	95 O'Leary Ave,	Regina	525-5841	1625-8th Avenue
Halifax	454-5851	3377 Kempt Rd.	Saskatoon	242-1296	509-44th St E.
Moncton	854-8600	400 Edinburgh Dr.	Calgary	253-7561	810-59th AveSE
Chicoutimi	549-0368	1533, boul. Talbot	Calgary	253-756	11316-11th Ave SW
Montreal	631-9471	2125, 23 ave.	Edmonton	452-7920	14760-116th Ave NW
Quebec	656-1025	2385, rue Watt	Edmonton	437-3660	4484-97 St NW
Rimouski	724-9224	170 rue industrielle	Red Deer	343-2113	1-7743 - 50th Avenue
Sept-Iles	962-6552	253, avenue Joliette	Abbotsford	859-3111	34446 S. Fraser Way
Hamilton	528-8811	1910 Barton St. E.	Kamloops	374-2112	961A Laval Crescent
Kitchener	893-6630	10 Goodrich Drive	Kelowna	860-3918	1936 Kent Road
London	1-800-265-8241		Nanaimo	758-1777	1809 Freemont Road
Ottawa	733-2500	1800 Bank St.	Prince George	562-3306	2223 Nicholson St N.
Sarnia	336-0722	1127 N. McGregor St.	Surrey	588-6501	13811-103rd Avenue
Sudbury	673-8413	48 Pacific Ave.	Trail	368-6474	1050 Eldorado St.
Thunder Bay	622-0638	700 Norah Crescent	Vancouver	688-0277	1000 Beach Avenue
Toronto	445-0550	840 York Mills Rd.	Victoria	382-7265	481 Cecelia Road
Windsor	966-2300	59 Eugenie St. E.	Burnaby	299-5566	6000 Lougheed Hwy.
Winnipeg	772-9401	1460 Ellice Avenue			

Westinghouse products for electrical utilities are available through the listed Utility Sales offices. Call the office nearest you.

### Utility Sales Offices

Fredericton	454-6952	460-440King St.	Winnipeg	772-9906	1460 Ellice Acve.
Halifax	422-4441	720 Barrington St Tower	Calgary	265-1204	707-324 8th Ave SW
Montreal	842-2566	2723-1, Complexe Desjardins	Edmonton	428-7540	516-10303 Jasper Ave
Toronto	595-9551	1012-790 Bay St.	Burnaby	299-5566	6000 Lougheed Hwy.

## For Service

Westinghouse Service Centres provide after-sales service, installation and start-up supervision, also testing and inspection, system verification, field repairs, alignment and balancing, rewind of all types of motors and generators, modification and rebuilding for all makes of electrical and mechanical equipment. Call the centre nearest you for service at all hrs.

### Service Centres

St. John's	722-7282	89 O'Leary Ave,	Sudbury	674-3356	48 Pacific Avenue
Dartmouth	469-8400	71 Wright Avenue	Swastika	642-3252	Westinghouse Ave.
Sydney	562-2242	RR2 Marion Bridge	Thunder Bay	577-4267	635 Mountdale Avenue
Moncton	382-4457	80 Enterprise St.	Toronto	255-8551	55 Goldthorne Ave.
Campbellton	753-3590	144 Water Street	Windsor	944-0121	4080 E.C. Row Ave. E.
Saint John	542-7708	71 Crown Street	Winnipeg	775-8643	1460 Ellice Avenue
Montreal	748-8811	180, rue Authier	Regina	352-5606	545 Dewdney Ave. E.
Quebec	656-1026	2385, rue Watt	Saskatoon	934-5251	800-47th Street E.
Sept-Iles	962-9803	180, rue Maltais	Calgary	273-0991	1856 Centre Ave. S.E.
Chicoutimi	549-6968	1533 Boul. Talbot	Edmonton	465-7541	8011 Davies Rd., NW
Hamilton	545-1151	717 Woodward Ave.	Ft. McMurray	743-8123	8204 Fraser Avenue
Kingston	389-8565	637 Justus Drive	Nanaimo	758-9171	2311 McCullough Road
Kitchener	744-1161	20 Alpine Court	Prince George	562-5571	2235 Nicholson St N.
London	453-0470	45 Pacific Court	Vancouver	278-9841	13300 Vulcan Way
St. Catharines	277-1020	475 Glendale Avenue			
Sarnia	337-3285	348 Queen Street S.			

**You can be sure...if it's Westinghouse**

## General Description

CSA Standard C22.2 No. 178-1978 defines an automatic transfer switch as, "self acting equipment for transferring one or more load conductor connections from one power source to another." The same Standard also gives definitions for type A and type B automatic transfer switches. "Transfer" switch type A means an automatic transfer switch that does not employ integral overcurrent devices." "Transfer switch, type B means an automatic transfer switch that (does) employ integral overcurrent protection". Westinghouse Robonics in type A are equipped with special instantaneous magnetic only interrupter. The trip settings of these special interrupter are set (and fixed) at higher than standard values. They are intended to trip only if the upstream protective device fails to clear a fault. Incorporating these special magnetic only interrupter, a type A Robonic operates in exactly the same way as a transfer switch not having this feature. In the event that both devices trip, the Robonics control circuitry will automatically initiate transfer to the alternate source. The transfer operation will reset the "tripped" magnetic only interrupter. Information on instantaneous trip value, interrupting, closing and withstand ratings, and recommendations for maximum upstream protective devices for type A Robonics, are given in tables 1, 2, 3 on page 7. The information given in these tables is necessary for proper application. Type B "Robonics" are equipped with standard thermal-magnetic breakers which will provide the required overload and short circuit protection. Type B Robonics can also be built using Seltronic or SCB breakers which could include ground fault tripping as well as overload and short circuit protection. For application information or assistance with type B Robonics, refer to Westinghouse.

The Robonic II provides automatic transfer of an electrical load to a stand-by power supply in the event of drop or loss of voltage of any or all phases of the normal power supply. Upon the restoration of the normal supply, the electrical load is automatically re-transferred to the normal power supply.

The transfer motor utilizes the power from the source to which the electrical load is being transferred. The mechanism is also designed to leave both breakers trip free in the closed position, permitting incorporation of the thermal and short-circuit protection in either or both breakers. In the higher ampacity models, type RO and PRO, an alarm switch contact is supplied. This contact is connected in the transfer motor circuit to lock the motor circuit out of operation when the breaker(s) trip on an overload or short-circuit condition. Then the breaker has to be manually reset. Instructions for the reset procedure are located on the front of the operating mechanism.

All of the control modules are plug-in units which are easily replaced.

## Mechanical Component Identification

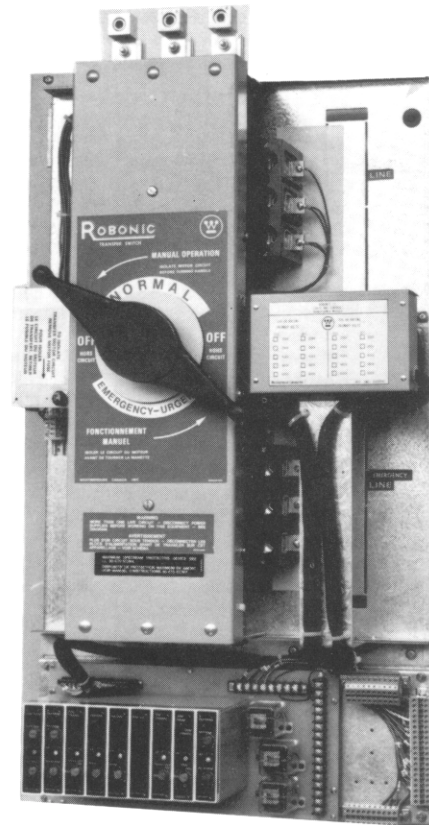

Type RO

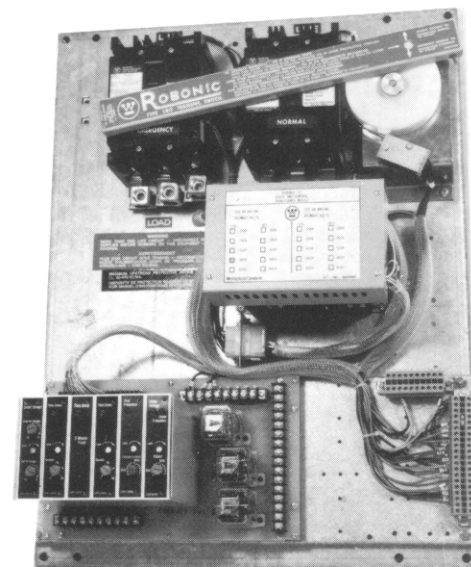

Type LRO

### Solid State Logic Control Panel

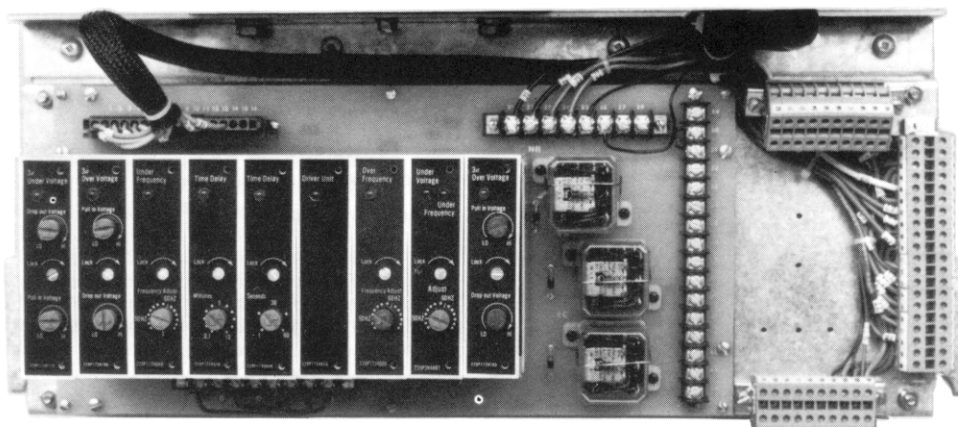

### Type LRO Robonic II Automatic Transfer Switch

Rated 30 amperes through 100 amperes at 600 volts Ac maximum 50 or 60 Hertz.

The mechanism is a lever operated device controlled by a 120 volt unidirectional motor.

The transfer motor drives a nylon cam which in turn operates a steel lever by sliding a pin along a slot in the back of the lever. The lever, in turn, operates the two breaker handles. The distance travelled is determined by two projections on the cam. These projections operate two micro switches (NLS, ELS) which in turn disconnect the power to the transfer motor causing a brake to operate.

The type LRO has three operating positions. They are the normal breaker closed and the emergency breaker open, the emergency breaker closed and the normal breaker open or both the normal and emergency breakers open but never both normal and emergency breakers closed.

The type LRO can also be easily manually operated. Open the lever cover, remove the slide pin and place it in the hole supplied in the lever cover and close the cover. Then the lever can be manually operated for what ever position desired without interference by the automatic control. For automatic control again, simply align the lever slot with the hole in the operating cam and replace the slide pin.

The various automatic control components are described under the section titled "Logic Control".

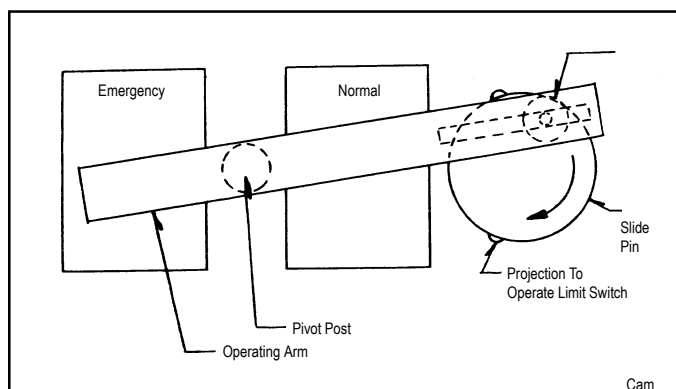

### Type "RO" Robonic II Automatic Transfer Switch

A complete line rated from 150 amperes through 1000 amperes at 600 volts Ac or at 250 volts Dc.

The transfer mechanism consists of the transfer motor, a gear train and two breaker operating cams.

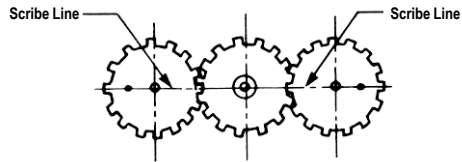

#### Spur Gear Meshing Relationship (bottom view of top cover)

The transfer motor drives the centre gear which in turn operates the two secondary gears. There is a projection in the secondary gears which slides in a groove in the operating cams moving the cams from side to side. The breaker handles are set inside two outer guides of the cam and are also moved from side to side. There are two micro switches (NLS, ELS) inside the breakers which are operated by the breaker's main contacts to disconnect the transfer motor power supply and allow the brake to operate.

The type "RO" transfer switch has three operating positions, the normal breaker closed and the emergency breaker open, the emergency breaker closed and the normal breaker open or both the normal and the emergency breakers open but never both the normal and emergency breakers closed at the same time.

The type "RO" Robonic II Transfer Switch is also easy to operate manually. Simply remove the transfer motor fuse and turn the black handle on the front of the transfer mechanism in a counter clockwise direction until you hear the breakers operated and the indicator is in the desired position. There will be no interference from the solid state control. For automatic control again, replace the transfer motor fuse and the Robonic II transfer switch will seek the power available.

The various control components are described under the section titled Logic Control.

### Type "PRO" Robonic II Automatic Transfer Switch

Rated 1200 amperes through 3000 amperes at 600 volts Ac or 250 volts Dc.

The transfer mechanism consists of a transfer motor, a gear train and two breaker operating cams.

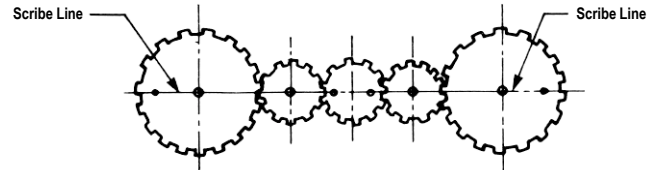

#### Spur Gear Meshing Relationship (bottom view of top cover)

The transfer motor drives a centre gear which in turn drives two inner secondary gears. These two inner gears then drive larger, outer secondary gears. There are projections from these outer secondary gears which slide in a groove at the back of each operating cam moving the cam up and down. The breaker handles are set inside two outer guides on the cams, moving up and down with the cams. There are two micro switches (NLS, ELS) inside the breakers which are operated by the breaker's main contacts to disconnect the transfer motor power supply and allow the brake to operate.

The type "PRO" transfer switch has three operating positions, the normal breaker closed and the emergency breaker open, the emergency breaker closed and the normal breaker open or both the normal and emergency breakers closed at the same time.

The type "PRO" Robonic II Automatic Transfer Switch is also easy to operate manually. Simply remove the transfer motor fuse and turn the black handle on the front of the transfer mechanism in a counter-clockwise direction until you hear the breakers operated and the colour indicator shows the desired position. For automatic control again, replace the transfer motor fuse and the Robonic II Transfer switch will seek the power available.

The various control components are described under the section titled Logic Control



**Table 1 — Interrupting, Closing and Withstand Rating — Robonic Type A**

Robonic Continuous Rating	Type	rms symmetrical amperes		
		600 Vac	480 Vac	120,208,240 Vac
30 to 100 amps	LRO	14,000	14,000	18,000
150 to 225 amps	RO	22,000	22,000	25,000
300 to 1000 amps	RO	22,000	30,000	42,000
1200 to 3000 amps	PRO	65,000	65,000	125,000

Since type A Robonics employ magnetic only breakers, their interrupting, closing and withstand ratings are the same value. Under fault conditions, with it's "normal" breaker closed, a Robonic is required to withstand the energy let through of the normal service protective device while the fault is being cleared. At the same time, should the normal voltage fall below the voltage sensing relay's selected value, - and if the alternate source were available, the Robonic could transfer before the normal service protective device cleared the fault.

This would require that the Robonic be capable of interrupting the protective device's let through current. In addition, the Robonic could be required to close in on a fault. Thus can be seen the need for Robonics to have, interrupting, closing and withstand ratings.

The interrupting, closing and withstand ratings shown in Table 1 are those for standard type A Robonics. For higher values, consideration can be given to use of Robonics built with Mark 75, Tri-Pac or SCB breakers.

**Table 2 — Maximum Upstream Circuit Protective Devices for Type A Robonics, All Classes of Loads**

Robonic		Maximum Upstream Breaker Frame Size	Maximum Upstream Fuse-Rating <sup>†</sup>	
Type	Continuous Rating (amps)		Class J or L	Class K5 or R
LRO	30	EB, EHB, FB, HFB, FB-P	100	100
LRO	70	EB, EHB, FB, HFB, FB-P	100	100
LRO	100	FB, HFB	100	100
RO	150	CA, CAH, JA, KA, HKA, LC, HLC, LA-P	225	225
RO	200	DA, LBB, LB, HLB, LC, HLC, LA-P	225	225
RO	225	DA, LBB, LB, HLB, LC, HLC, LA-P	225	225
RO	300	DA, LBB, LB, HLB, LC, HLC, LA-P	400	400
RO	400	LA, HLA, LC, HLC, NB-P	400	400
RO	600	MA, HMA, MC, HMC, NB-P	600	600
RO	800	NB, HNB, NC, HMC, PB, PC, PB-P	800	...
RO	1000	PB, PC, PB-P	1200	...
PRO	1200	PB, PC, PB-P	1200	...
PRO	1400	PB, PC	2000	...
PRO	2000	PB, PC	2000	...

<sup>†</sup> Fuse ratings given are as allowed by C.E.C. If other ratings are desired, refer to C.E.C.

**Table 3 — Maximum Upstream Circuit Protective Devices for Type A Robonics, 90% or Larger Motor Load**

Robonic		Maximum Upstream Breaker Frame Size	Maximum Upstream Fuse-Rating <sup>†</sup>	
Type	Continuous Rating (amps)		Class J or L	Class K5 or R
LRO	30, 70, 100	EB, EHB, FB, HFB, FB-P LA-P c/w 400LAP10	300	100
RO	150,200,225	CA, CAH, JA, KA, HKA, LA, HLL, LB, HLB, MA, NB, HLC, MC, HMC, NC, HNC, LA-P, NB-P c/w 500 NAB12	400	225
RO	400	LB, HLB, LC, HLC, LA, HLA, LA-P MA, HMA, MC, HMC, NB, HNP, NC, MNC, NB-P	600	400
RO	600, 800	MA, HMA, MC, HMC, NB, MNB, NC, MNC, NB-P	1200	600
RO	1000	NB, HNB, NC, HNC, PB-P	1200	...
PRO	1200	NB, HNB, NC, HNC, PB-P	1200	...
PRO	1400, 2000	PB, PC, PB-P	2000	...

<sup>†</sup> Fuse ratings given are as allowed by C.E.C. If other ratings are desired, refer to C.E.C.

**Logic Control**

**Voltage Sensing Modules**

- 1Ø Undervoltage S# 1266C79G04 Option#5C, 26B
- 3Ø Undervoltage S# 1266C79G03 Option#5C, 26A

These cards are normally set at 70% dropout and 90% pickup.

- 1Ø Overvoltage S# 1266C79G02 Option#5B, 26C
- 3Ø Overvoltage S#12266C79G01 Option#5B, 26C

These cards are normally set at 105% pickup and 115% dropout. All styles are applicable to both emergency and normal source monitoring.

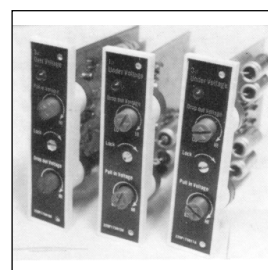

**Frequency Sensing Modules**

- 1Ø Underfrequency S#1275C74G04 Option#5D, 26D
- 1Ø Overfrequency S#1275C74G06 Option#5E, 26E

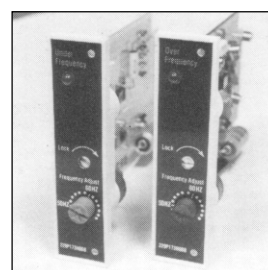

Both under and overfrequency cards are factory calibrated at 60 Hz. The actual values of pickup and dropout are as follows:

Type	Dial Setting Hz	Pickup Hz	Dropout Hz
Underfrequency	60	57	55
Underfrequency	50	47	45
Overfrequency	60	63	65
Overfrequency	50	53	55

**Undervoltage / Underfrequency Module**

S#1288C58G01 Option# 5A, 26F  
Monitors one phase of power source.

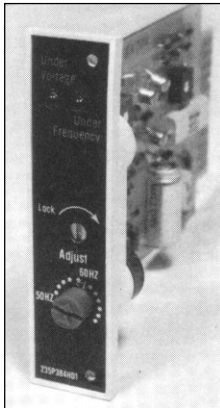

**Time Delay Modules**

1-60 sec. timer S#1275C74G01 Option#1A, 3A, 4A  
 0.1-10 min. timer S#1275C74G02 Option#1B, 3B, 4B  
 0.2-30 min. timer S#1275C74G03 Option#1C, 3C, 4C  
 5 min fixed S#1275C74G08 Option#4D

All can be used to accomplish TDEC, and TDNE functions.

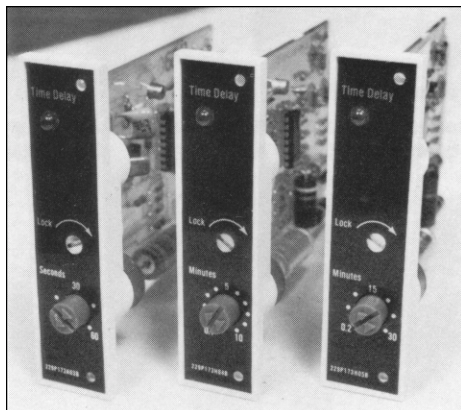

**Relay Driver**

S#1266C77G02 Option#1A, 1B, 1C, 3A, 3B, 3C, 4A, 4B, 4C, 4D

This card is used in place of any of the timing modules when instantaneous operation is required.

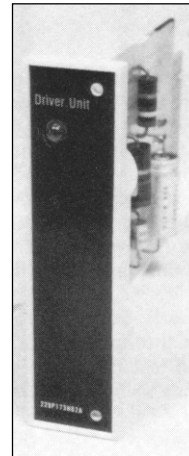

**Blank**

S#1266C77G01

Used to cover any unused card slots.

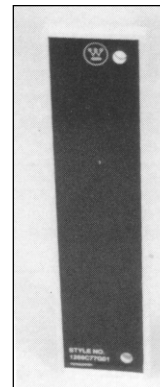

**All Cards Mechanically Interlocked**

All cards are interlocked mechanically to prevent insertion into the wrong function slot. All cards have a repeat accuracy over a 20 to +60°C temperature change of (+ or -) 3%. Dial settings are (+ or -) 10% of indication.

After making adjustments, tighten locking screw to secure setting. Tighten mounting screws (screws are not captive).



## Adjustments

Timer and frequency modules can be adjusted as per module front plate. Voltage sensing modules can be adjusted as follows:

### Undervoltage Module

Set	Description
1	Set Dropout knob maximum Counter-clockwise
2	Set pick-up knob maximum Counter-clockwise
3	Increase line volts to desired Dropout value (normally 70%) LED should be "ON"
4	Rotate Dropout Clockwise until LED goes "OFF"
5	Rotate Pick-up to maximum Clockwise LED is "OFF"
6	Increase line volts to desired Pick-up value (normally 90%) LED is "OFF"
7	Rotate Pick-up knob Counter-clockwise until LED comes "ON"
8	Re-check Pick-up and Drop-out by running voltage up and down check by LED indication.

### Overvoltage Module

Step	Description
1	Set Dropout to maximum Counterclockwise
2	Set Pick-up to maximum Counterclockwise
3	Set line voltage to pull in value desired (normally 105%) LED is "OFF"
4	Rotate Pick-up Clockwise until LED comes "ON"
5	Rotate Dropout maximum Clockwise
6	Set line voltage to Dropout value desired (normally 15%)
7	Rotate Dropout Counterclockwise until LED is "OFF"
8	Drop line voltage to pull-in desired value. LED should come "ON"
9	Increase line voltage to desired Dropout value. LED should go "OFF"

### DT and DTM Time Delay Relays Option #32A, 32B

Ratings - 6 Watts Power Consumption  
 Input coil Voltage - 120 volts  
 Contact Rating - 3 amperes at 220 volts Ac 50/60 Hertz  
 Operating Temperature Rating - -10°C to +50°C  
 Time Ratings - Various available

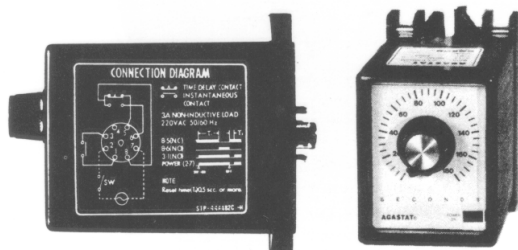

The relay is incorporated in the control scheme to stop the transfer switch with both breakers open. This is to allow residual load voltage to decay prior to closing on another supply which could be out of phase. When the timing cycle is complete, the relay re-initiates transfer to the available source.

### Time Delay Engine Starting Relay

#### Solid State Type Option #2A

Ratings - 1.2 Watts Power Consumption  
 Input coil voltage - 120 volts at 50/60 Hertz.  
 Contact Rating - 10 amperes resistive at 120 volts  
 Time Range - 2 to 3 seconds - nonadjustable.  
 Operating Temperature Range - -10°C to +55°C.

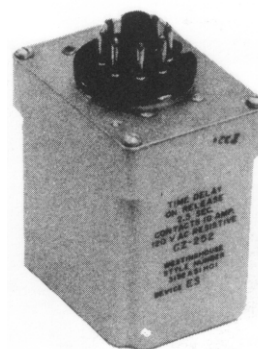

#### Pneumatic Type Option #2B

Rating - 8 Watts Power Consumption  
 Input Coil Voltage - 120 volts 50/60 Hertz.  
 Contact Rating - 10 amperes resistive at 120 volts Ac.  
 Time Ranges - Various available.  
 Operating Temperature Range - -30°C to +75°C.



This time delay relay is an actual plug-in, synchronous motor type. It is complete with clutch and mechanical load switch giving one instantaneously operated normally open contact and a timed single pole double throw contact in a dust-tight grey capsule. The mechanism is constructed to operate for the time set on the indicating dial and then disconnect itself when the timing cycle is complete. A red pilot light on the face plate indicates that the relay is timing to operate its contacts. When de-energized, the relay requires a reset time of at least 0.5 seconds. Time delay begins immediately upon energizing the coil.

When the timing cycle is complete, a mechanical latch holds the contacts in position and the coil is de-energized.

**Transformer Modules**

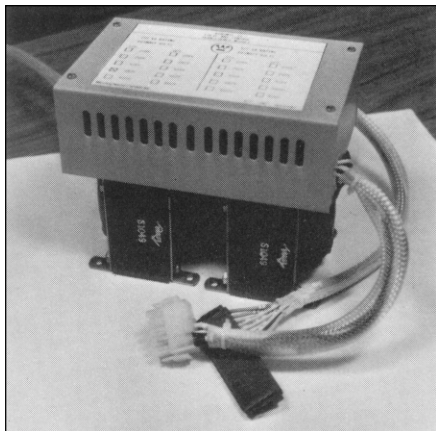

Modules include all necessary control, voltage sensing and logic transformers.

Two versions are available. The standard module has three phase monitoring of the normal source and one phase monitoring of the emergency source. The optimal module has three phase monitoring on both the normal and emergency sources.

**Plant Exerciser Option# 23A, 23B, 23C**

Ratings - Input voltage 120 volts  
 Contact rating 20 Amps at 120 volts resistive S.P.D.T.

**Description**

Dial A is divided into a 24 hour day and night scale, and has tabs around the periphery which may be adjusted to operate the micro switch within intervals each 24 hours. Each tab represents a 15 minute interval. Dial B has 7 spokes and advances one position for each revolution of Dial A. Each spoke has provision to add a pin to operate the micro switch. These pins represent days of the week and their function is to prevent operation of the micro switches on selected days.

**Application**

The plant Exerciser is a Program Time Switch which functions to start and stop the engine-generator set and transfer switch automatically at pre-selected intervals or times. It consists of a synchronous electric motor and a gear assembly to rotate a dial 360° each day for a week (168 hours). On the periphery of the dial there are levers or tabs which can be set to operate a mechanical load switch as dial rotates. These levers can be selected to operate the switch at specific times of the day daily or specific days of the week. The cycle repeats weekly. The Plant Exerciser may be used in two different ways as an accessory for transfer switches.

1. It may to simulate an interruption in the normal source of supply at selected intervals, at least once per week, causing the transfer switch components to function, including start-up of the engine-generator set and transfer of load to the generator supply. At the end of the interval it will initiate the transfer back to normal supply and shut down the engine-generator.

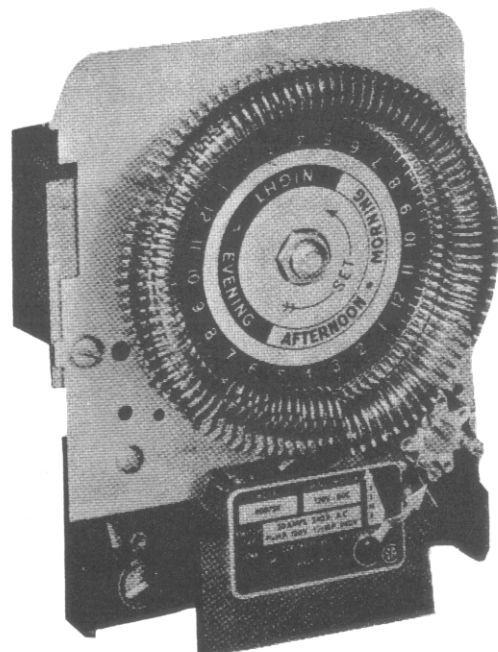

or

- It may be used to start an engine-generator set at selected intervals, at least once per week, but without causing the transfer switch to operate and transfer the load to the generator supply. At the end of the interval it will cause the engine-generator to shutdown.

**INSTRUCTIONS — TO OPERATE THE ENGINE FOR AN INTERVAL ONCE EACH WEEK, WITH OR WITHOUT OPERATION OF THE TRANSFER SWITCH.**

- Extend the tabs of Dial A outwards, except those representing the time of day for the running of the engine or operation of the transfer switch.
- Determine the day of the week for this testing. Install the six brass pins (called skip pins) in the spokes of Dial B representing the other six days of the week.
- Turn Dial A counterclockwise until the special tab at 12:00 midnight advances Dial B. Turn Dial B until present day of the week is opposite the copper arrow. Turn Dial A counterclockwise until the correct time of day (or night) is opposite the arrow on the nameplate.
- If the interval of running the engine is desired more than one day per week but at the same time of day, remove the skip pin from the appropriate spoke of Dial B.

**Caution**

DO NOT insert skip pins in any spoke when that spoke is pointing towards the copper arrow



**Portable Test Kit #50**

An inexpensive, portable test kit, #1278C67G01, is available for convenient field testing and calibration of all plug-in cards and output relays. The only power source required is a 120V convenience outlet. A selector switch allows the operator to test individual cards or to simulate ATS operation by having the source monitoring cards drive the time delay cards which in turn drive the output relays, exactly as in actual use. Calibration checks or changes can thus be accomplished without necessity of energizing the alternate power source.

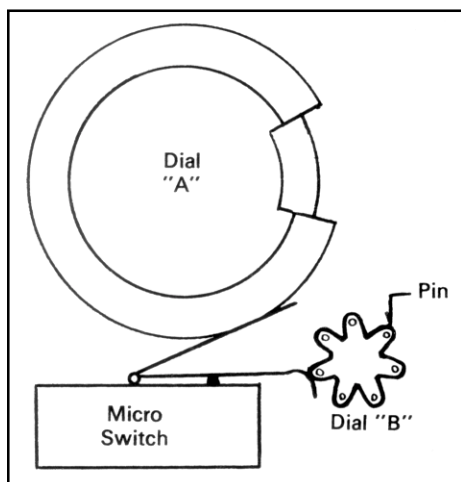

**Schematic of Robonic II Transfer Switch**

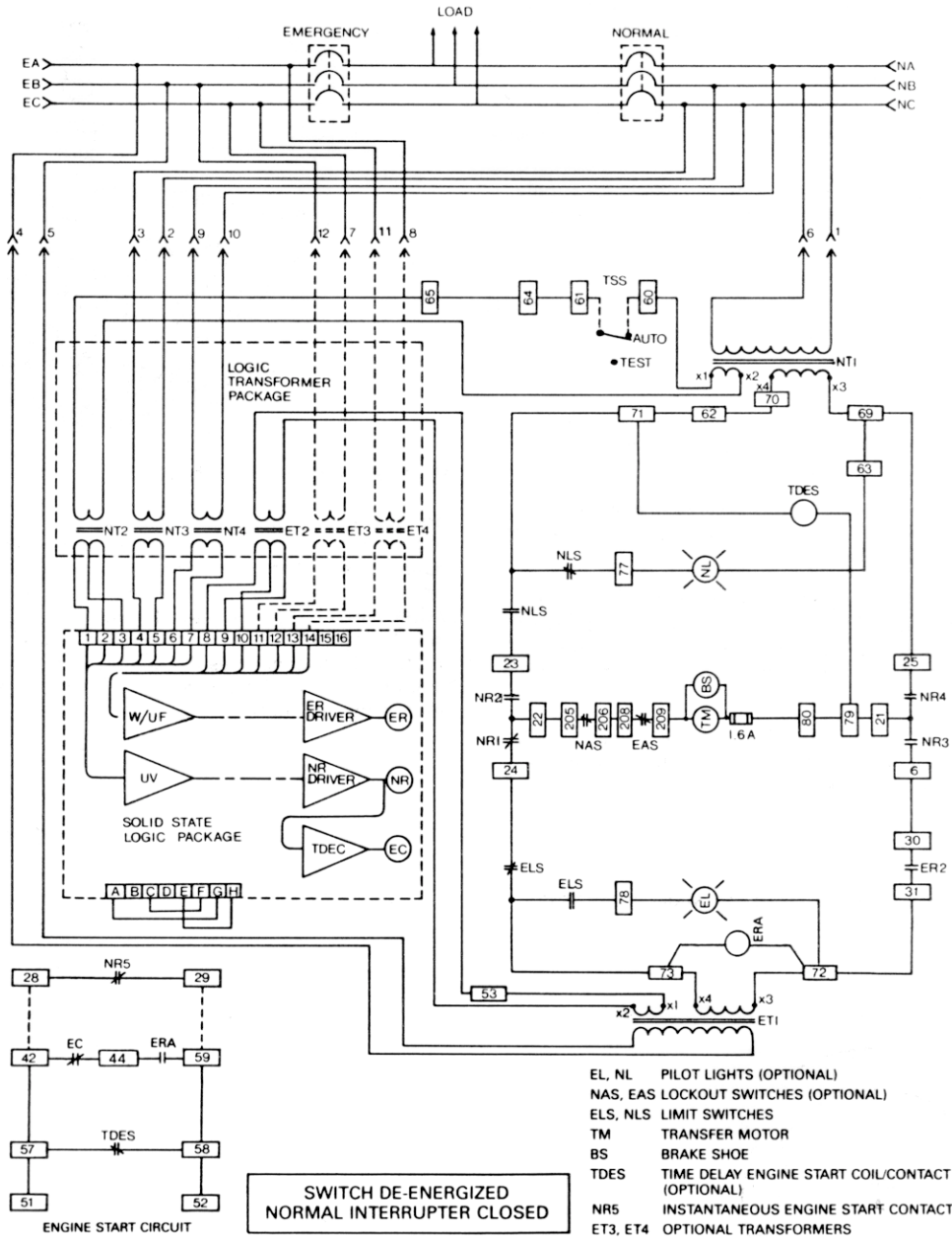

Consider the Robonic II in the normal operating position, with normal power available and the normal interrupter closed. The following are energized: U.V. (undervoltage module), TDES (time delay engine start), and NR (normal relay).

The U.V. monitoring all 3 phases of the normal power, senses a dip or loss of voltage which instantly causes NR to deenergize. Contacts NR2 and NR4 open, and contacts NR1 and NR3 close. TDES times out, closing its contacts and initiating the emergency system start up. When the emergency system reaches correct levels of voltage and frequency, ER is energized and contact ER2 closes. This completes the emergency control circuit, and TM (transfer motor) begins to operate.

First, the normal interrupter is opened, and then the emergency interrupter is closed. At this point, the ELS (emergency limit switch) contacts change state, and the BS (motor brake) closes, preventing TM over travel. The NLS (normal limit switch) contacts change state in preparation for re-transfer to the normal power source.

Upon return of stabilized normal power, NR is re-energized disabling the emergency control circuit, and enabling normal control circuit. The TM operates, opening the emergency interrupter and closing the normal interrupter. When the re-transfer is completed, the NLS contacts change state isolating TM, and BS closes. TDES becomes energized opening its contacts. TDEC times out to allow the emergency generator to run unloaded and cool off before shutting down. The Robonic II is now ready to react to another normal power failure.

**Replacing Parts**

The Robonic Automatic Transfer Switch has been designed to have all components accessible and readily removable from the front of the panels. The Robonic Transfer Switch is divided into two basic sections. The upper section consists of the main contacts and transfer mechanism, the lower section consisting of all the automatic control devices.

**Caution**

When replacing any parts of the mechanism, control transformers or breakers, isolate the Robonic Transfer Switch from any possible source of power.

To remove the transfer mechanism of the LRO transfer switch, first open the cover and remove the slide pin from the operating cam, then remove the centre bolt, the mechanism will lift straight off. The breakers and transfer motor bracket are held by four screws for ease of removal and replacement. When replacing the mechanism, first set it on the Robonic with the breaker handles in the holes provided and then fasten the centre bolt reasonably tight with the mechanism fully movable with an equivalent swing distance up and down.

To remove the transfer mechanism of the RO transfer switch, remove the four bolts holding it, taking note of which holes the bolts were in, then lift the mechanism straight off. The breakers are held by two bolts at one end and the bus connectors on the other end. The transfer motor is mounted to the transfer mechanism cover and centre drive gear. When replacing any part of the transfer mechanism, be sure that the scribe lines of the gears are in a straight row (example shown on page 6).

To prevent operation of the transfer switch while replacing mechanism or components, disconnect all sources of power.

When replacing the mechanism move it about until the breaker toggles fit between the mechanism fingers and then fasten the bolts tightly. To test for proper operation first operate manually and then connect 120 volt, 60 Hertz supply to motor leads and observe operation for free movement and proper breaker operation.

The PRO transfer switch mechanism is similar to the RO with the exception that the PRO mechanism has five gears and is mounted horizontally. The breakers are fastened to the panel by six bolts.

All Robonic transfer switch breakers and mechanisms have allowed some adjustments for mounting to assure proper operation without slipping or binding. Be sure all hardware is tightened sufficiently before re-energizing any transfer switch.

To replace any of the octal plug-ins relays, pull old units straight out and insert the replacement unit. Due to the tight fit of the receptacle and pins, you may have to move the relay about a little to pull it out. **DO NOT INTERCHANGE ANY RELAY WITH ANY OTHERS.**

To replace any solid state logic modules, pull straight out and insert the replacement unit.

**Parts List**

Part Name	Style No.	
<b>Parts Common to Robonic II</b>		
<b>Plug-in Modules</b>		
Timer,1-60 sec. adjustable, for TDEN,TDEC,TDNE	1275C74G01	
Timer,0.1-10 min. adjustable, for TDEN,TDEC,TDNE	1275C74G01	
Timer,0.2-30 min. adjustable, for TDEN,TDEC,TDNE	1275C74G03	
Timer, 5 min. adjustable, for TDEN,TDEC,TDNE	1275C74G08	
Relay driver — used in place of timers, for instantaneous operation	1266C77G02	
Instantaneous relay, used for NR,ER and EC 1Ø under frequency module, for “normal” or “emergency”	1275C74G04	
1Ø over frequency module, for “normal” or “emergency”	1275C74G06	
3Ø over voltage module, for “normal” or “emergency”	1266C79G01	
1Ø over voltage module, for “normal” or “emergency”	1266C79G02	
3Ø under voltage module, for “normal” or “emergency”	1266C79G03	
1Ø under voltage module, for “normal” or “emergency”	1266C79G04	
Blank cover, for unused module space	1266C77G01	
Time delay relay for engine starting, 2.5s fixed	3152A51H01	
Time delay relay for engine starting, adjustable 1-300s	688A886H11	
<b>Options</b>		
Plant Exerciser	688A888G01	
Battery Charger 12V	1259C26G01	
Battery Charger 24V	1259C26G03	
4 Position s/s fixed	7070A56H01	
4 Position s/s keyed	7070A56H02	
<b>Transformer Modules</b>		
600V, for LRO, RO	160D997G05	160D997G15
480V, for LRO, RO	160D997G04	160D997G14
416V, for LRO, RO	160D997G03	160D997G13
240V, for LRO, RO	160D997G02	160D997G12
208V, for LRO, RO	160D997G01	160D997G11
600V, for PRO	160D997G10	160D997G20
480V, for PRO	160D997G09	160D997G19
416V, for PRO	160D997G08	160D997G18
240V, for PRO	160D997G07	160D997G17
208V, for PRO	160D997G06	160D997G16
<b>For Type LRO Robonic II</b>		
Mechanism	833C222G02	
Motor Assembly	833C223G01	
Motor	688A732H02	
Operating Cam	688A458G01	
Slide Pin	688A731H01	
Limit Switch	688A747H01	
<b>For Type RO Robonic II</b>		
Mechanism 150 to 400A	833C226G01	
Mechanism 600 to 1000A	833C226G01	
Motor	688A749H01	
Solenoid	688A740H01	
Brake Shoe Assembly	688A738G01	
Operating Cam	572B774H01	
Auxiliary & Limit Switch	688A747H01	
<b>For Type PRO Robonic II</b>		
Mechanism	688A109G01	
Motor	688A749H02	
Solenoid	688A740H01	
Auxiliary & Limit Switch	688A747H01	



**Trouble Shooting Guide**

Symptoms	Possible Causes
<ul style="list-style-type: none"> <li>refusal to re-transfer to normal source upon restoration</li> </ul>	<ul style="list-style-type: none"> <li>a voltage sensing relay did not energize</li> <li>emergency to normal time delay relay has failed</li> <li>a loose control connection</li> </ul>
<ul style="list-style-type: none"> <li>will not transfer to emergency source upon failure of normal source</li> </ul>	<ul style="list-style-type: none"> <li>engine-generator did not start</li> <li>generator not producing enough voltage at a high enough frequency</li> <li>a loose control connection</li> <li>normal to emergency time delay, if supplied, has failed</li> <li>if voltage sensing modules supplied in emergency, there may be a failure of one</li> </ul>
<ul style="list-style-type: none"> <li>transfer without a power failure in the normal source</li> </ul>	<ul style="list-style-type: none"> <li>a voltage sensing module has failed</li> <li>emergency to normal time delay has failed</li> </ul>
<ul style="list-style-type: none"> <li>no time delay when there should be</li> </ul>	<ul style="list-style-type: none"> <li>that particular time delay has failed</li> </ul>
<ul style="list-style-type: none"> <li>engine-generator starts when the normal source has not failed</li> </ul>	<ul style="list-style-type: none"> <li>the engine start time delay has failed</li> <li>a plant exerciser has been built into the system</li> <li>a voltage sensing module has failed</li> </ul>
<ul style="list-style-type: none"> <li>normal source has failed and the transfer switch cycles without stopping in emergency</li> </ul>	<ul style="list-style-type: none"> <li>the operating cam in the mechanism has either broken or come out of the breaker handle</li> <li>ELS has failed to operate</li> </ul>
<ul style="list-style-type: none"> <li>if the power is not available on the load terminals with either the normal or emergency sources available and the transfer switch will not operate</li> </ul>	<ul style="list-style-type: none"> <li>the breakers may be complete with trip units and if there has been a fault on the system, the motor circuit has been opened by either EAS and NAS. Correct and manually reset the breakers in the transfer switch</li> </ul>

**Recommended Maintenance**

- DO NOT perform dielectric tests on the equipment with the control components in the circuit.
- DO NOT use loctite.
- Check lubricant in high speed bearings of the motor and the low speed bearings of the gear box. For lubrication use Dow Corning Silicon DC44 or equivalent on the high speed bearings and Aero Shell No. 6 grease or equivalent in gear box after 5000 operations.
- Check if control components are tight in sockets.
- Periodically inspect all terminals (load, line and control) for tightness. Retighten all bolts, nuts and accessible hardware. Clean or replace any contact surfaces which are dirty, corroded or pitted.
- Robonics should be in clean, dry and moderately warm locations. If signs of moisture are present, dry and clean transfer switch. If there is corrosion try to clean off, if cleaning is unsuitable replace the corroded parts. Should dust and/or debris gather on the transfer switch, brush, vacuum or wipe clean. DO NOT blow dirt into breaker or terminals.
- Test the transfer switch operation. While the Robonic is exercising, check for freedom of movement, hidden dirt or corrosion and any excessive wear on the mechanical operating parts. Clean, lubricate or replace parts where necessary.
- Check all adjustable control components (time delay and voltage sensing relays) for correct settings.
- If the type "RO" mechanism is removed be sure that the scribe lines on the gears are in line. When reassembling the drive mechanisms be sure that they are fastened to the correct holes in the frame and that the breaker handles are between the cam fingers (one breaker has to be on and the other off).

Note: When servicing logic control, or transformer module, disable the motor circuit

**Type LRO Robonics**

**CAUTION**

DO NOT overtighten the pivot screw inside the operating arm. This screw was correctly adjusted at the factory to provide low friction movement of the operating arm without excessive play.

DO NOT overtighten the set screw holding the operating cam on the motor shaft.

## Free Manuals Download Website

<http://myh66.com>

<http://usermanuals.us>

<http://www.somanuals.com>

<http://www.4manuals.cc>

<http://www.manual-lib.com>

<http://www.404manual.com>

<http://www.luxmanual.com>

<http://aubethermostatmanual.com>

Golf course search by state

<http://golfingnear.com>

Email search by domain

<http://emailbydomain.com>

Auto manuals search

<http://auto.somanuals.com>

TV manuals search

<http://tv.somanuals.com>