



Westinghouse

wired™



WST1500-1509 Special Edition Series Upright Vacuum

You can be sure...if it's Westinghouse™

IMPORTANT SAFETY INSTRUCTIONS

This electrical appliance must always be used according to the following safety instructions:

READ ALL INSTRUCTIONS CAREFULLY BEFORE USING THIS APPLIANCE

WARNING: To reduce the risk of fire, electric shock or injury:

1. Always turn the appliance off before unplugging it.
2. Always unplug the appliance before cleaning or servicing it. Do not unplug by pulling the cord; to unplug, grasp the plug, not the cord.
3. Do not leave the appliance plugged in or running while unattended.
4. Do not pull or carry the appliance by the cord. Do not run the appliance over the cord, close a door on the cord, or pull the cord around sharp edges or corners. Keep the cord away from heated surfaces.
5. Do not use the appliance if the cord or plug is damaged.
6. Avoid the use of extension cords.
7. Do not handle the plug or appliance with wet hands.
8. Do not use appliance outdoors, or on wet surfaces.
9. Do not use appliance to vacuum up water or damp materials such as mud, tile grout, plaster filler, or caulking.
10. Do not use appliance to vacuum up flammable or combustible liquids, such as gasoline. Do not use in areas where these liquids may be present.
11. Do not use this appliance to vacuum up burning or smoking materials, such as cigarettes, matches or hot ashes.
12. Keep hair, loose clothing, and all parts of the body, especially fingers, away from openings and moving parts.
13. Do not put any objects into appliance openings, or use with any openings blocked or plugged.
14. Do not use this appliance to pick up hard or sharp objects or other large surface litter. Pick these up by hand before vacuuming.
15. Do not operate without the Collection Bin properly in place.
16. Always vacuum stairs with the appliance below you.
17. Do not allow the appliance to be used as a toy. Do not use or leave appliance plugged in near small children or infants.
18. Always use the Cleaning Wand / Hose (and attachments) to clean upholstery.
19. Use the appliance only for normal household use, as described in this Use and Care Guide. Use only with manufacturer's recommended attachments and accessories.
20. Turn appliance off before removing or replacing the Collection Bin or Filter Cartridges.
21. Unplug appliance before cleaning or maintenance, such as cleaning the Rotating Brush, removing a blockage, or replacing a light bulb.
22. This appliance is protected from overheating by an automatic reset thermal limiter. If the appliance shuts itself off, unplug it and check for blockages. Allow it to cool for 30 minutes before restarting.
23. If the appliance is not working as it should, or if it has been dropped, damaged, left outdoors or dropped into water, return it to an authorized Service Center for inspection or repair. Do not repair the appliance yourself, as this will invalidate your warranty. Contact Consumer Service for return authorization, examination, repair or adjustment.

SAVE THESE INSTRUCTIONS

FOR HOUSEHOLD USE ONLY

Westinghouse Wired™ WST1500 Special Edition Series Vacuum Cleaner Features

Product may vary slightly from illustrations

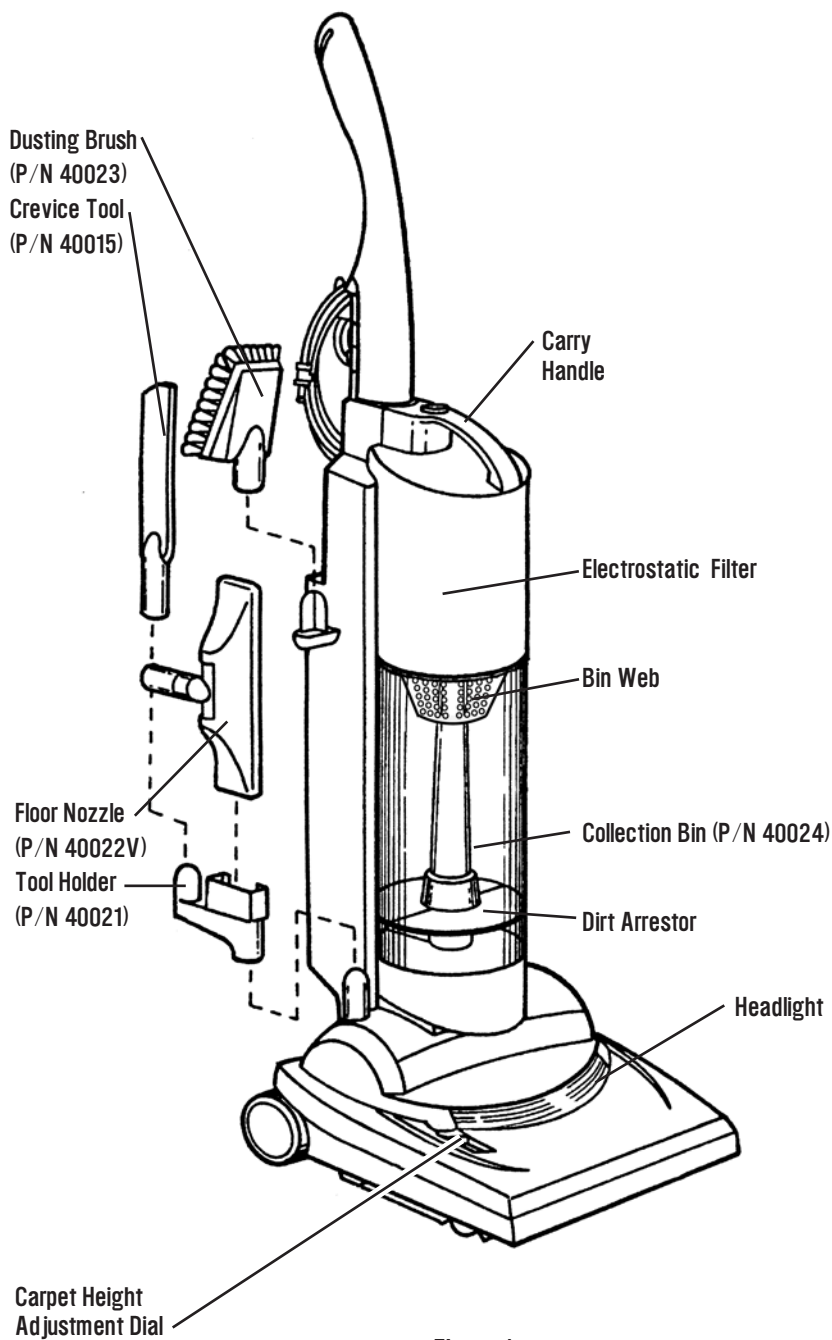

Figure 1a

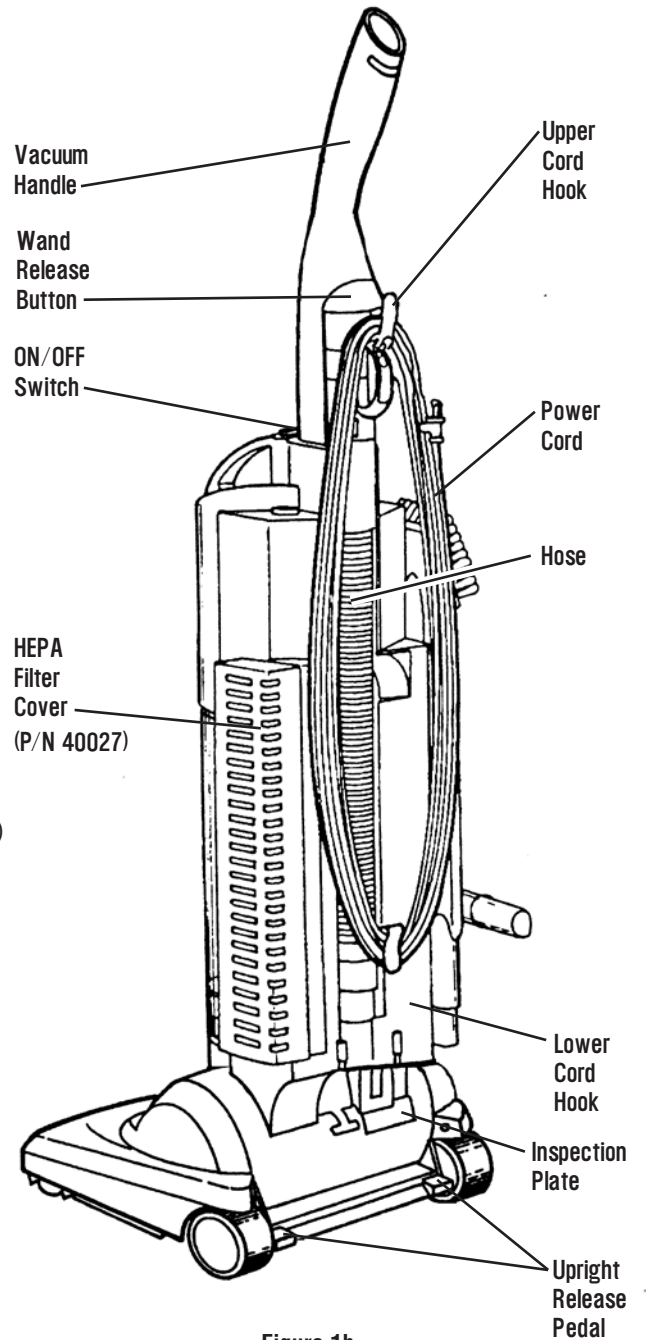

Figure 1b

NOTE: UNIT SHOWN WITH HANDLE IN UPRIGHT STORAGE POSITION.

Polarized Plug

This appliance has a polarized plug (one blade is wider than the other.) To reduce the risk of electric shock, this plug is intended to fit into a polarized outlet only one way. If the plug does not fit fully in the outlet, reverse the plug. If it still does not fit, contact a qualified electrician. Do not attempt to modify the plug in any way.

OPERATING INSTRUCTIONS

In order to get the most out of your Westinghouse WST1500 Series Vacuum Cleaner, we suggest you read the easy step-by-step instructions thoroughly before starting to vacuum.

ASSEMBLING YOUR VACUUM

1. Remove the Westinghouse WST1500 Vacuum Cleaner from its box.
2. Carefully remove all plastic packing materials from the Vacuum Cleaner. Check to make sure you remove all the Tools and Accessories before throwing out the packing materials.

ACCESSORY/PARTS LIST

- Upper Handle
- Vacuum Cleaner Body
- Telescopic Cleaning Wand
- Tool Holder
- 10 Foot Hose Extension (optional accessory)
- Spare Replacement Belt

Cleaning Tools

- Crevice Tool
- Floor Nozzle
- Dusting Brush

Using the Telescopic Cleaning Wand and Hose

The Cleaning Wand is stored inside the Hose.

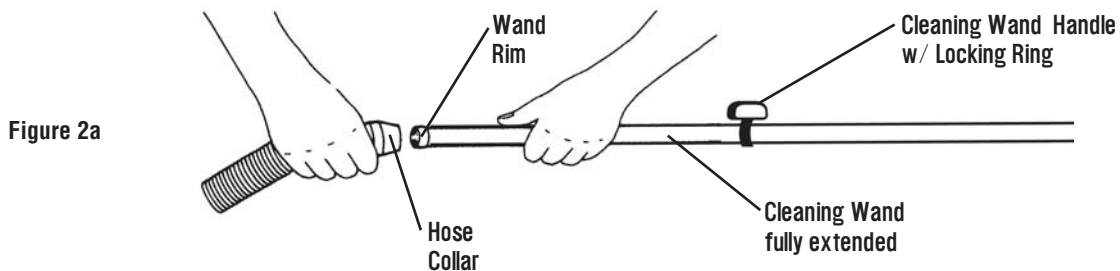

1. The Cleaning Wand comes assembled inside into the Hose. (See Figure 2a.)
2. Press the Wand Release Button. Slide the Telescopic Cleaning Wand out of the Hose Collar by gripping the Collar in one hand and the Cleaning Wand Handle in the other. Pull to extend, then grasp the end of the Wand to extend the Wand to its full length. The Wand should slide out easily. Once the Wand is at the desired length, lock the Wand into place by turning the Handle w/ Locking Ring clockwise. (See Figure 10b.)
3. When you are finished using the Telescopic Cleaning Wand, turn the Locking Ring counterclockwise to unlock. Slide it back into itself and into the Hose. Compress the Hose just like you would an accordion so all of the retaining rings fit close together.
4. Grasping the Cleaning Wand Handle, guide it up into its storage position. (See Figure 1b.)
5. Push up on the Handle until it snaps and locks into place in the channel at the back of the Vacuum Cleaner, under the Wand Release Button.

CLEANING TOOLS

The Westinghouse WST1500 Vacuum Cleaner comes with 3 On-Board Cleaning Tools and a Tool Holder.

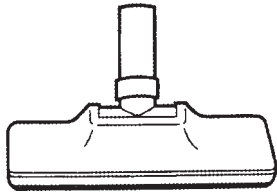

Figure 3a
Floor Nozzle
(P/N 40022V)



Figure 3b
Dusting Brush
(P/N 40023)

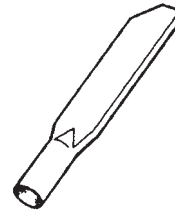

Figure 3c
Crevice Tool
(P/N 40015)

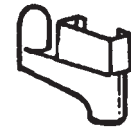

Figure 3d
Tool Holder
(P/N 40021)

Floor Nozzle

Use the Floor Nozzle to clean low, hard-to-reach spaces, under furniture, where dust and dirt accumulate. It's also a great way to clean stairs. Good for bare floor surfaces.

Dusting Brush

The Dusting Brush has short, soft bristles to remove pet hair, lint and fine dust particles. Use it to clean drapes, blinds and upholstered furniture.

Crevice Tool

The Crevice Tool is a long narrow tool with a rounded larger end and a flat tapered end. Use to reach and clean difficult nooks and crannies between furniture and appliances, along baseboards or under cabinets where cobwebs, lint and dust like to hide.

Cleaning Tools Storage

Each Tool has its own special storage spot on board the Vacuum Cleaner. The Floor Nozzle and the Crevice Tool fit in the Tool Holder. The Dusting Brush has its own Mounting Peg. (See Figure 1a.)

1. Locate the Tool Holder Mounting Post on the bottom left side of the Vacuum Cleaner.
2. Position the Tool Holder so that the dome-shaped cylinder fits right on top of the Mounting Post. (See Figure 4a.)
3. Slide and press the Tool Holder down to secure it into place.

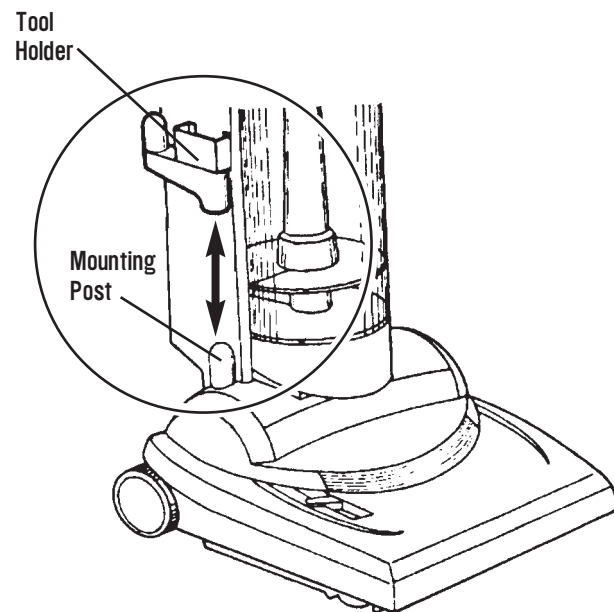

Figure 4a

Storing The Floor Nozzle

1. Turn the Floor Nozzle on its side.
2. Grasping the round extension, slide the flat end of the Nozzle front into the Tool Holder Cup. (See Figure 4b.)

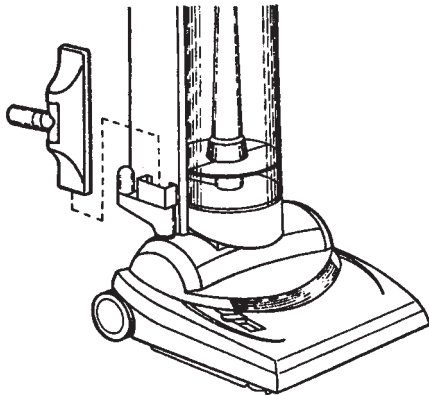

Figure 4b

Storing The Crevice Tool

1. Fit the wide end of the Crevice Tool onto the dome-headed cylinder of the Tool Holder. (See Figure 4c.)
2. Make sure it fits snugly so it won't fall off.

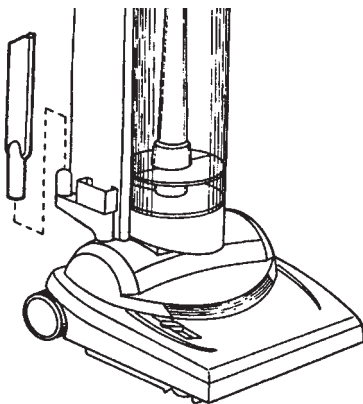

Figure 4c

Storing the Dusting Brush

1. Locate the Dusting Brush Mounting Peg. It's the small crossed post on the top left side of the Vacuum Cleaner. (See Figure 4d.)
2. Slide the Dusting Brush onto the Peg and secure it into place.

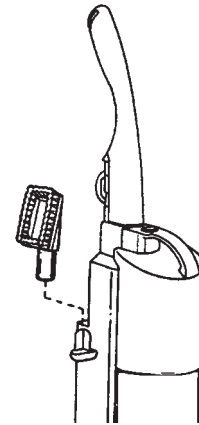

Figure 4d

Using the Power Cord

The Westinghouse WST1500 Vacuum Cleaner comes with a 25 foot Power Cord so you can move easily from room to room without plugging and unplugging your Vacuum Cleaner.

1. Uncoil the Power Cord which is coiled tightly for shipping.
2. The top of the Hose Handle splits as you rotate the top portion upwards, creating the Upper Cord Hook.
3. Wind the Cord around the Upper and Lower Cord Hooks on the side of the Vacuum Cleaner to store. (See Figure 5a.)

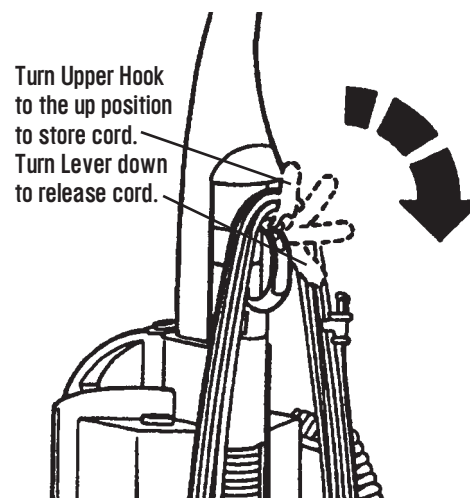

Figure 5a

4. When you are ready to release the cord, simply rotate the Upper Cord Hook down over the top of the Hose Handle. The cord slips easily off the machine, with no tangles or twists.
5. Plug the Cord into a 120V AC electrical outlet.

Power Cord Storage

The Power Cord stores easily on the side of the Vacuum Cleaner.

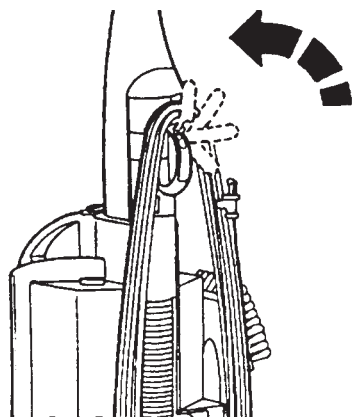

Figure 6a

1. Position the Upper Cord Hook so it points up. (See Figure 6a.)
2. Wind the Cord first around the Upper Hook and, then, around the Lower Hook.
3. Continue to wind until the cord is completely coiled.
4. Secure the plug to the cord so it doesn't unravel. The rubber grip built onto the plug will fit around the cord and keep it in place. (See Figure 6b.)

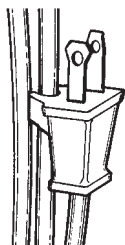

Figure 6b

Transporting Your Vacuum Cleaner

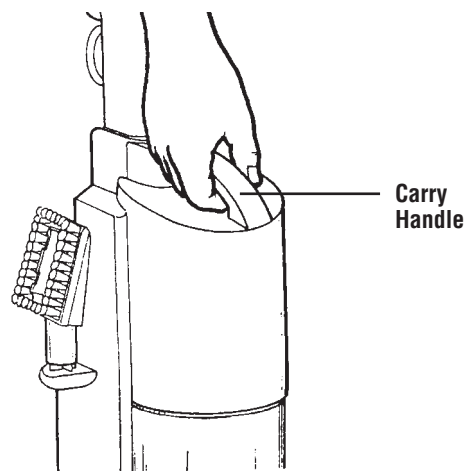

Figure 7

Use the convenient, easy-to-grip Carry Handle to transport your Vacuum Cleaner up and down the stairs.

1. Return the Westinghouse WST1500 Vacuum Cleaner to its upright position.
2. Locate the Carry Handle on the top of the Vacuum Cleaner. (See Figure 7.)
3. Secure your hand firmly under the Carry Handle.
4. Lift the Vacuum Cleaner up or down stairs.

Tools and Tips

Always use the Upper Handle or Carry Handle to pull your Vacuum Cleaner from room to room. Never pull your Vacuum Cleaner by the Hose. Doing so may damage the Vacuum Cleaner Hose.

Preparing To Vacuum

Your Westinghouse WST1500 Vacuum Cleaner is designed to clean a variety of surfaces: Carpets, Bare Floors and Above Floors.

Vacuum Cleaner Controls: ON/OFF Button

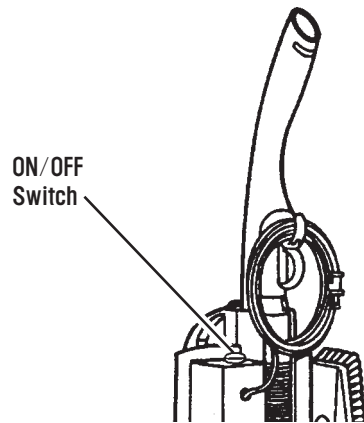

Figure 8

1. The ON/OFF Button is located at the base of the Upper Handle. It is marked with "O" and "-". (See Figure 8.)
2. To turn the Vacuum Cleaner ON, depress the ON/OFF Button to its down position.
3. Press the Button again to turn the Vacuum Cleaner OFF. The Button will raise to the upper position.

Cleaning Carpets

Your Westinghouse WST1500 Vacuum Cleaner can be adjusted to any height of carpet. The 3-Way Carpet-Height Adjustment Slide lets you adjust the Rotary Brush to the proper brush height for your carpets.

1. The Carpet Height Adjustment Slide is located on the top of the Base Cover, next to the Headlight. (See Figure 9a.)
2. With the Vacuum Cleaner OFF and in the upright locked position, push the Slide to the top for Low Pile, to the center for Medium Pile or to the bottom for High Pile.

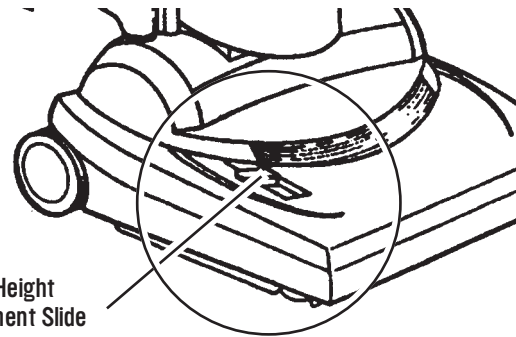

Figure 9a

4. Locate the Upright Release Pedal on the bottom back side of your Vacuum Cleaner between the 2 wheels. (See Figure 9b.)

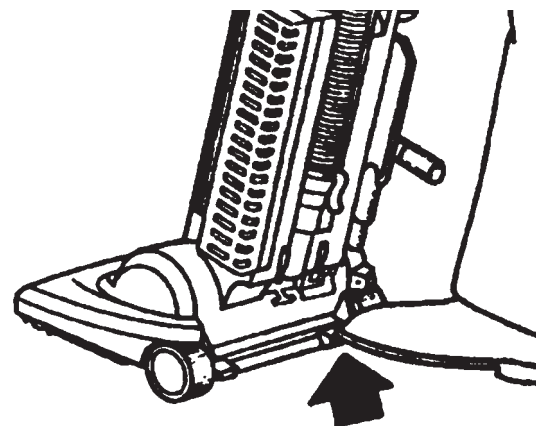

Figure 9b

5. Grip the Upper Handle with 1 hand and press down on the Pedal with either foot.
6. Tilt the Vacuum Cleaner back into a comfortable position.
7. Push the Vacuum Cleaner onto the carpet and begin vacuuming.

Safety Tip

Make sure you turn your Vacuum Cleaner OFF whenever you make any adjustments or lift the Vacuum Cleaner up or remove any part.

CAUTION: Be sure to keep fingers and toes away from the moving Rotary Brush.

Cleaning Bare Floors

1. Steer the Westinghouse WST1500 Vacuum Cleaner onto the bare floor you want to clean. Return your Vacuum Cleaner to its upright, locked position.
2. Attach the Floor Nozzle to the Telescopic Cleaning Wand or Hose. (See "Using Your Telescopic Cleaning Wand" section of this manual.)
3. Use the Floor Nozzle to clean tiles or hardwood floors.

Tools and Tips

The Westinghouse WST1500 Vacuum Cleaner Hose is made with reinforced steel. Its coils will stay flexible and in good shape for the life of your Vacuum Cleaner.

Cleaning Above Floors

The 10 Foot Telescopic Cleaning Wand, gives you makes easy work to vacuum hard-to-reach, above-floor areas.

1. Return your Vacuum Cleaner to its upright position. (You may assemble while Vacuum Cleaner is either ON or OFF.)
2. Rotate the Upper Cord Hook down so that it fits snugly on top of the Hose Handle. Grab the Hose Handle and press down firmly on the colored Wand Release Button. (See Figure 10a.)
3. The Telescopic Cleaning Wand will release easily from the back of the Vacuum Cleaner.

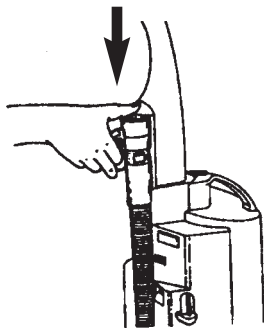

Figure 10a

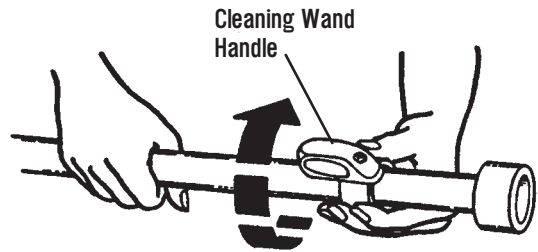

Figure 10b

Lock the Wand into place by turning the Locking Ring clockwise.

4. Slide the Telescopic Cleaning Wand out of the Hose Collar by gripping the Collar in one hand and the Cleaning Wand Handle in the other. Pull to extend.
5. Grasp the Wand Rim in one hand, and use your other hand to extend the Wand to its full length. (See Figure 10b.) Keep pulling it until it reaches the length you want. With the Hose and Cleaning Wand fully extended, there are 10 feet to work with.
6. If the Wand won't pull out easily, twist the Locking Ring counter-clockwise and loosen slightly.
7. Once the Wand is at the desired length, lock the Wand into place by turning the Handle w/ Locking Ring clockwise.
8. Notice that the airflow is automatically redirected from the Power Head to the Telescopic Cleaning Wand.
9. All On-Board Cleaning Tools will attach onto the end of the Telescopic Cleaning Wand.
10. To return the Cleaning Wand to its locked position inside the Hose, grasp the Hose handle to place it into the channel at the back of the Vacuum. Push the Handle upwards until the Wand locks into place with a click.

Tools and Tips

When using the Cleaning Wand, do not leave the appliance in one place for an extended period of time as the Rotary Brush continues to turn. Tilt the Vacuum Cleaner back using the Upper Handle to protect more delicate surfaces.

Attaching Cleaning Tools To The Wand

1. Select the appropriate Cleaning Tool for the vacuuming job.
2. Release the Cleaning Wand.
3. Slide the Tool into the top of the Cleaning Wand.
4. Firmly press the Tool in place. It should fit snugly.

Attaching Cleaning Tools To The Hose

You can also attach your Cleaning Tools directly onto the Hose. This will give you the flexibility to clean delicate china or fine collectibles that must be dusted carefully.

1. Remove the Wand from the Hose. Extend the Cleaning Wand as far as it will reach out of the Hose.
2. Hold the Hose Collar in one hand and, using your thumb and forefinger, press in both of the Hose Collar Latches. (See Figure 11a.)

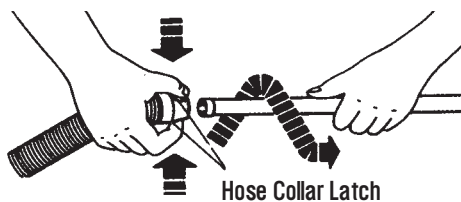

Figure 11a

3. With your other hand, pull the Wand all of the way out of the Hose Collar. (See Figure 11a.)
4. Insert any Attachment directly into the Hose Collar. (See Figure 11b.)

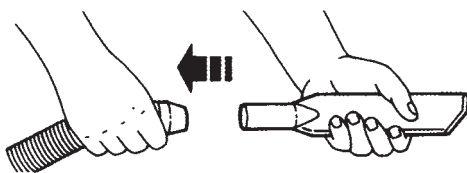

Figure 11b

Tools and Tips

If you're having difficulty removing the Cleaning Wand from the Hose Collar, rotate the Wand as you pull it out. With continued use, the rubber Hose Collar will soften and the Cleaning Wand will pull out more easily.

Using the Hose Extension (Optional Accessory)

If you have extra high ceilings or staircases, you may want to purchase a Hose Extension. It will give you additional cleaning reach. To purchase a Hose Extension or any of the other cleaning accessories, turn to the "Accessory/Parts List" in this manual.

Using The Hose Extension

1. Remove the Cleaning Wand from the Hose following the instructions outlined in the "Attaching Cleaning Tools to the Hose" section of this manual.
2. Push the Tabs around the rim of the Hose Collar.
3. At the same time, twist the Nozzle of the Optional Hose Extension into the Hose Collar. Make sure it slides in all the way.
4. If extra reach is needed, insert the Cleaning Wand into the Hose Extension Collar.
5. Select the appropriate Cleaning Tool and attach to either the Wand or directly to the Hose Extension.
6. Vacuum as usual.

Removing The Hose Extension

Always remove the Optional Hose Extension after you've finished your cleaning task.

1. Push in the Tabs of the Extension Hose Collar. This will release the Wand from the Collar.
2. Pull out the Cleaning Wand.
3. Remove the Optional Extension Hose by pushing in the Tabs of the Vacuum Cleaner Hose Collar and pulling out the Hose Extension Nozzle.
4. Slide the Cleaning Wand back into the Hose Collar.

Proper cleaning and maintenance will ensure the highest operating performance of your Westinghouse WST1500 Vacuum Cleaner.

USER MAINTENANCE INSTRUCTIONS

Emptying the Collection Bin

The Westinghouse WST1500 Vacuum Cleaner's see-through Collection Bin fits inside a Storage Compartment. It will fill up quickly, so it's a good idea to empty it after every use.

1. Return your Vacuum Cleaner to its upright position.
2. **Always press the ON/OFF Button to turn the Vacuum Cleaner OFF before you empty the Collection Bin.**
3. Unplug the Vacuum Cleaner.
4. Make sure that the swirling action inside your Collection Bin has come to a complete stop.
5. Make sure the Rotary Brush has stopped moving.
6. Locate the Release Button on top of the Carry Handle.
7. Press down on the Release Button and tilt away the Collection Bin. (See Figure 12a.)
8. Holding the Carry Handle, grasp the bottom of the Collection Bin. (See Figure 12b.)

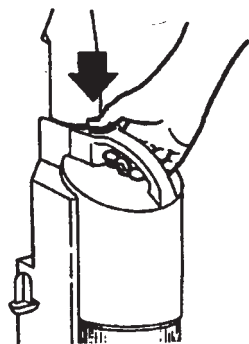

Figure 12a

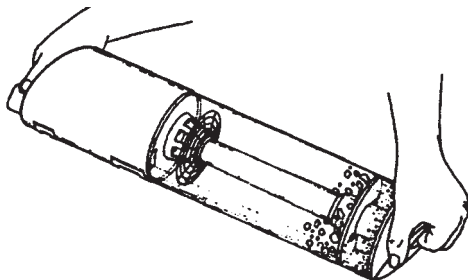

Figure 12b

9. Turn the Carry Handle a quarter turn counter-clockwise to its "unlocked" position and remove Collection Bin Cover. (See Figure 13c.)

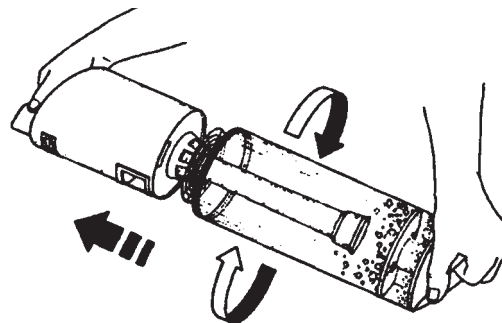

Figure 12c

10. Turn the Collection Bin upside down over a trash can. Make sure you empty all dirt and debris from above and below the Dirt Arrestor. To ensure that all the dirt spills out, tap the side of the Collection Bin gently against the edge of the trash can. (See Figure 12d.)

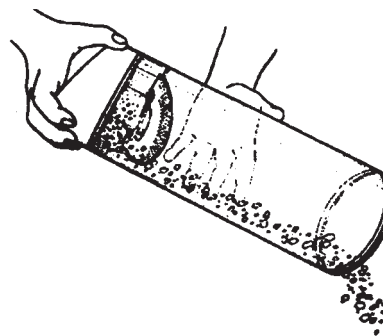

Figure 12d

Health Tip

If you suffer from allergies or asthma, take the Collection Bin outdoors to empty. As you empty the dirt into the trash can, gently tap the Collection Bin against the side of the can to remove loose debris.

Cleaning The Collection Bin

The Collection Bin should be washed periodically.

1. Wash the Bin in warm water using a mild soap. Avoid harsh or abrasive cleaners or sponges. Rinse thoroughly.
2. Let it air dry. **Make sure the Collection Bin is completely dry before putting it back into the Vacuum Cleaner.**

WARNING: THIS BIN IS NOT DISHWASHER SAFE.

Replacing The Collection Bin

After cleaning, the Collection Bin Cover and Collection Bin must be reassembled.

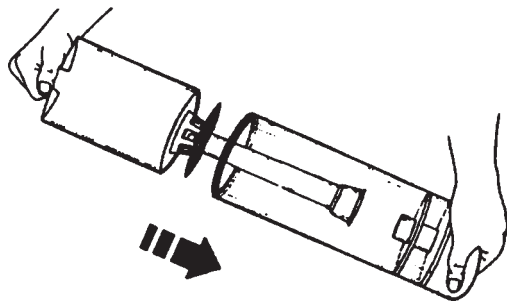

Figure 13a

1. Align the arrow on the Collection Bin Cover with the UNLOCK icon on the Collection Bin. (See Figures 13a and 13b.)

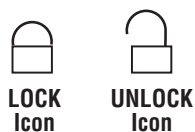

Figure 13b

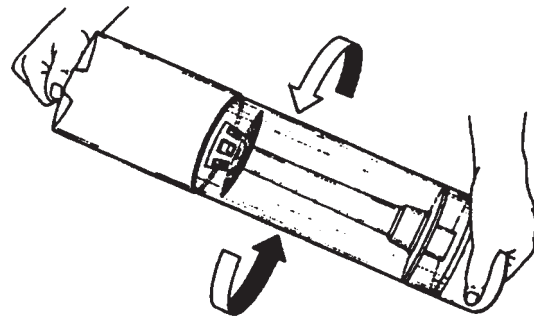

Figure 13c

2. Insert the Inner Tube back into the Collection Bin. (See Figure 13c.)
3. Rotate the Collection Bin Handle clockwise so that you line up the arrow on the Bin Cover with the LOCK icon on the Collection Bin.
4. Insert the reassembled Collection Bin bottom-first into the Storage Compartment. (See Figure 13d.)
5. Line up the recessed area on the bottom of Collection Bin with the Bin Mount at the base of the Storage Compartment. Make sure the Bin Catch snaps back into place on the Vacuum Cleaner. You should hear an audible "click."

WARNING: If the Collection Bin is not secured in place, a loss of suction while vacuuming could result.

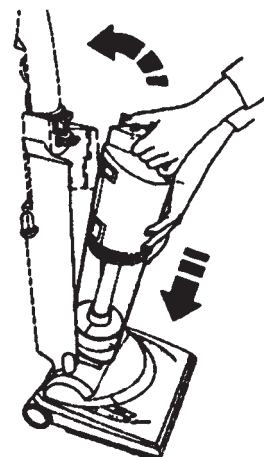

Figure 13d

Cleaning The Collection Bin Filter

To get the best possible performance from your Vacuum Cleaner you should clean the Collection Bin Filter after every use and wash once a month.

1. Remove the Collection Bin.
2. Pull out the Collection Bin Filter from its nest in the Collection Bin Cover. (See Figure 14.)

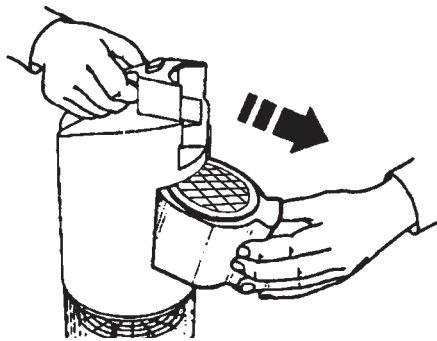

Figure 14

The Foam Filter is nested in the bottom of the Collection Bin Filter.

3. Remove the Foam Filter from the underside of the Filter Assembly by grasping the Plastic Post in the middle. Rinse in warm water and dry completely.
4. Wash the Collection Bin Filter with warm water and soap.
*For best results, immerse in soapy water for 30 minutes.
5. Hold the Filter under running tap water until water running out the bottom is clean and there is no remaining soap.
6. Shake out excess water.
7. **Air-dry the Collection Bin Filter thoroughly for at least 24 hours.**
8. Place the dry Foam Filter, with the larger round end of the Foam Filter's Plastic Post into the bottom (the smaller end of the Post remains visible) of the Collection Bin Filter. Then insert the Collection Bin Filter back into its storage nest inside the Collection Bin Cover with the Foam Filter on the bottom.

Cleaning The HEPA Filter

The HEPA Filter will need cleaning once every 3 months to maintain optimal performance.

1. Locate the HEPA Filter. It's inside the long, narrow Housing on the side of the Vacuum Cleaner.

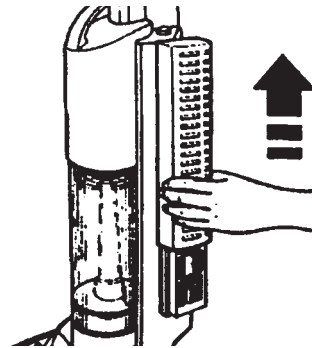

Figure 15a

2. Slide the Louvered Cover of the Housing up and off its Guide Rails. (See Figure 15a.)
3. The HEPA Filter fits snugly into the Filter Housing. Pull the tabs at the top and the bottom of the Filter to pull it away from the machine. Gently pull the Filter out of the Filter Housing. (See Figure 15b.)

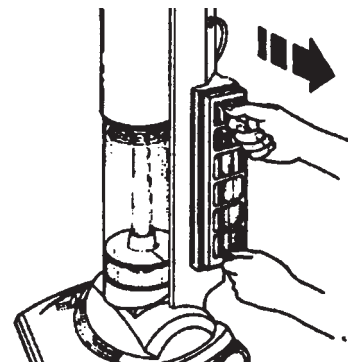

Figure 15b

4. Tap Filter gently against trash container to free and eliminate excess dirt and debris.

IMPORTANT! (DO NOT WASH HEPA FILTER)

We recommend that the HEPA Filter be checked every 3 months to maintain performance. Under normal circumstances, this Filter will seldom need to be replaced.

5. Replace the HEPA Filter into its Housing. Slide the Louvered Cover down into its locked position.

Cleaning The Rotary Brush

Hair, string and other debris can gather around the bristles and slow the Rotary Brush down.

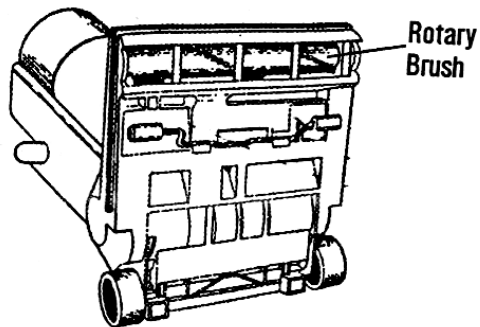

Figure 16a

1. Return the Westinghouse WST1500 Vacuum Cleaner to its upright position.
2. Press the ON/OFF Button making sure the Vacuum Cleaner is OFF, and unplug it from the electrical outlet.
3. Lay the Vacuum Cleaner on its back so that the Rotary Brush faces up. Remove the Base Cover. See section entitled: "How to Remove the Base Cover."
4. Clean out threads, pet hair and other debris that have gathered between the bristles of the Rotary Brush. (See Figure 16a.)
5. Remove any large objects that may have jammed in the Brush.

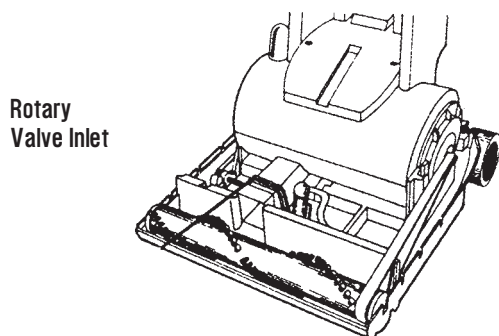

Figure 16b

6. Check the Rotary Valve Inlet to make sure it is not clogged with dirt or objects. (See Figure 16b.)
7. Replace and re-attach the Base Cover.

Replacing A Broken Belt

If your Vacuum Cleaner is not working properly, you may have a damaged Belt. Check to see that the Belt is not stretched or broken. If it is, you'll need to put on a Replacement Belt.

1. Unplug the Vacuum Cleaner.
2. Remove the Base Cover. (See the section entitled: Removing the Base Cover.)
3. Remove the Rotary Brush by pulling it straight up using both hands. (See Figure 17.)
4. Clean out the dirt and debris that may have accumulated between the metal plates and the ends of the Rotary Brush Assembly.
5. Remove the old Belt and discard it.

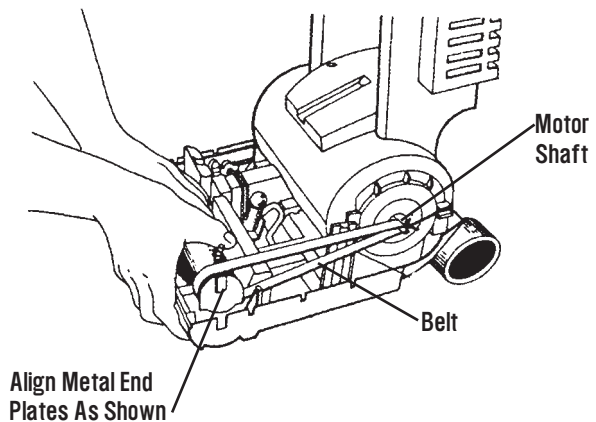

Figure 17

6. Fit the Replacement Belt around the Rotary Brush Assembly. **Make sure it is not twisted.**
7. Replace the Brush Assembly by aligning the metal ends so the points face down. (See Figure 17.)
8. Pull the Belt tightly over the Motor Shaft.
9. Rotate the Brush by hand to make sure that it rolls easily and the Belt stays in place.
10. Replace the Base Cover.

Replacing A Headlight Bulb

1. Unplug the Vacuum Cleaner.
2. Remove the Base Cover. See section entitled: "How to Remove the Base Cover."
3. Remove the burned out Bulb.
4. Press a new Bulb into the Bulb Socket.
5. Twist the Bulb into place.
6. Replace the Base Cover.

Replacement Bulbs

Additional replacement bulbs can be purchased using the "Accessory/Parts List" in this manual or by calling your nearest authorized Service Center toll free: 1-800-616-8689.

Removing A Blockage

The Westinghouse WST1500 Vacuum Cleaner may incur a loss of suction if there is a blockage.

1. Press the ON/OFF Button to turn the Vacuum Cleaner OFF.
2. **Unplug the Vacuum Cleaner.**
3. Turn the Vacuum Cleaner to rest the Base on its front. (See Figure 18.) Find the Inspection Plate located at the back of the Vacuum Cleaner.

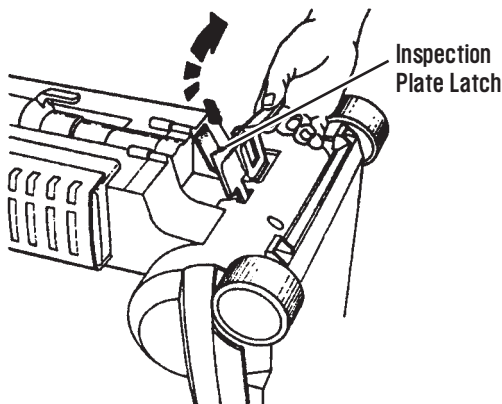

Figure 18

4. Turn the Latch on the Inspection Plate clockwise until it unlocks. (See Figure 18.)
5. Let the Inspection Plate drop down.
6. Look up into the Air Passageway for any fluff or debris.

7. Gently remove all debris using a long, straight tool such as a screwdriver.
8. Close the Inspection Plate Door.
9. Turn the Inspection Plate Latch counter-clockwise until the Plate is securely locked in position.
10. Return the Vacuum Cleaner to its normal upright position.
11. Plug in the Vacuum Cleaner and depress the ON/OFF Switch to turn it ON.

Checking for Additional Debris

Before returning the Collection Bin to its Storage Compartment, it's a good idea to check the following areas for any accumulation of dirt or lint.

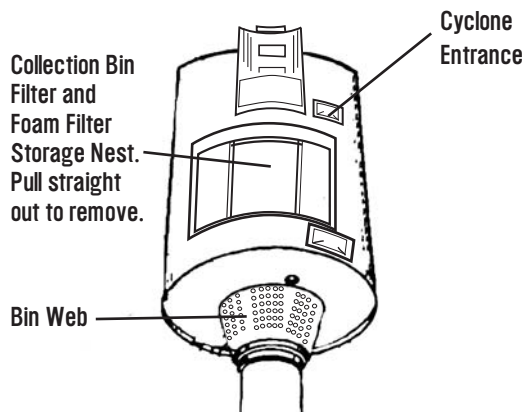

Figure 19a

1. Pull out any lint or debris clogging the Cyclone Entrance. (See Figure 19a.)
2. Wipe away any dirt or lint clinging to the Bin Web or to the surface of the inside of the container.
3. Make sure there is not a buildup of dirt or debris above or below the Dirt Arrestor. (See Figure 19b.)

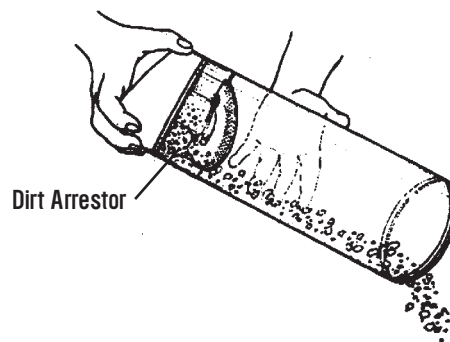

Figure 19b

Removing The Base Cover

You will need to remove the Base Cover from time to time to clean the Rotary Brush, check the Vacuum Belt, change a Headlight, or remove a blockage.

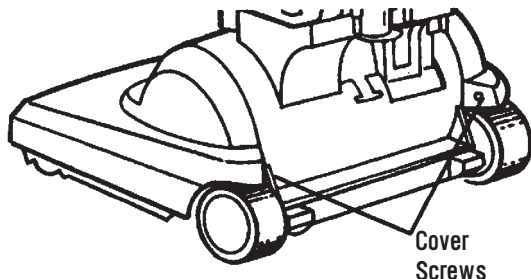

Figure 20a

1. Unscrew the screws located on the rear of the Base Cover. (See Figure 20a.)
2. Lay the Vacuum Cleaner on its back so that the Rotary Brush faces up.

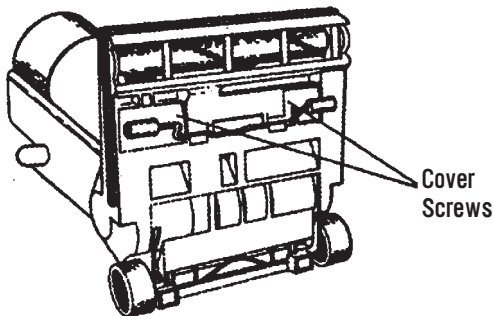

Figure 20b

3. Unscrew the screws located under the Rotary Brush. (See Figure 20b.)
4. Remove the Base Cover by placing your thumbs in the rear screw holes and pushing forward and up. This will disengage the 3 Cover Locking Tabs.
5. Pull the Base Cover away from the Vacuum Cleaner head.
6. When finished cleaning or removing a blockage, you must replace the Base Cover and refasten the screws. Be sure you don't over-tighten the screws.

Giving Your Vacuum Cleaner A Detailed Inspection

If you don't find a blockage, the Vacuum Cleaner shuts itself off or a loss of suction persists, you will need to give it a more detailed inspection.

1. Return the Vacuum Cleaner to its upright position.
2. Turn the Vacuum Cleaner OFF and unplug it.
3. Remove and clean the Collection Bin and Collection Bin Filter, Dirt Arrestor, and Foam Filter following the detailed instructions in the User Maintenance Instructions section in this manual.
5. Remove and clean the HEPA Filter following the detailed instructions in the section entitled: "Cleaning The HEPA Filter" section in this manual.
4. Remove any dirt or debris that may have accumulated in the Air Passageway or in the Cyclone Entrance.
5. Check the Rotary Brush and Rotary Valve Inlet. (See "Cleaning the Rotary Brush" section of this manual.)
6. Check the Belt to make sure it is in good condition. If it is broken or damaged, replace it. (See section entitled: Replacing a Broken Belt.)
7. Replace Collection Bin.

Safety Tip

Make sure you turn your Vacuum Cleaner OFF whenever you make any adjustments or lift the Vacuum Cleaner up or remove any part.

CAUTION: Be sure to keep fingers and toes away from the moving Rotary Brush.

TIP NO. 1 - MOVING THE HEIGHT ADJUSTMENT

You may find it difficult to adjust the carpet height button when the machine is resting on the floor. A simple method is to raise the head off the floor as shown below and slide the button to your preferred carpet height position.



TIP NO. 2 – BUMPER GUARD

If the bumper guard is pulled away from the base during use it may result in a loss of suction performance. To place the bumper back in position, remove the base cover (hood) and lock the bumper on the base in the slots provided. Then replace the base cover (hood) to resume cleaning. (see page 15 of the owner's manual for base cover removal and replacement steps)

Overload Protection

Your Westinghouse WST1500 Vacuum Cleaner has an Overload Protection System that automatically monitors the machine's temperature at all times and may shut off the Vacuum Cleaner to protect the motor from overheating. Here's what to do when this happens:

1. Turn your Vacuum OFF and unplug it.
2. Let the Vacuum sit for 30 minutes before turning it back ON.
3. Follow the detailed instructions in the section entitled: "Removing A Blockage" in this manual.
4. The Self-Resetting Overload Protector will automatically correct itself.
5. After 30 minutes, turn the Vacuum Cleaner back on.

Tools and Tips

If the Vacuum Cleaner still does not start, or if you are experiencing a sudden loss of suction power, phone toll free: 1-800-616-8689 for assistance.

Tools and Tips

If you are vacuuming in a very hot room, the cooling time could take longer.

QUESTIONS AND ANSWERS

The Westinghouse WST1500 Vacuum Cleaner is easy to use. Even so, you may have some questions about how it works. Here are answers to some of the most common questions. If you still have a question and can't find the answer here, please call Consumer Service toll free at: 1-800-616-8689 or e-mail Salton, Inc. at: salton@saltonusa.com.

Can I use the Westinghouse WST1500 Vacuum Cleaner outside?

No. The Westinghouse WST1500 Vacuum Cleaner is designed for indoor use only. Do not use the Vacuum Cleaner outdoors, or on wet indoor surfaces.

Are there any types of materials that should not be vacuumed up with the Westinghouse WST1500?

Yes. Do not vacuum up damp materials such as mud, tile grout, plaster-filler or caulking since these materials could harden inside the Vacuum Cleaner and cause damage. Also, do not pick up large surface litter, cellophane, twine or solid objects such as coins, paper clips, safety pins, etc. These types of objects can easily lodge in the rotating brush and will decrease suction and cleaning ability.

Will the Westinghouse WST1500 Vacuum Cleaner's wheels get stuck in my high pile carpets?

No. The Westinghouse WST1500 Vacuum Cleaner has extra wide wheels so you can push it easily over high pile carpets, uneven tile or wood floors.

How difficult is it to empty the Collection Bin?

We've designed the Westinghouse WST1500 Vacuum Cleaner's Collection Bin so that it's easy to handle and carry. The Lid firmly locks into place until it's time to empty the Bin. It's easy to see when the Bin is full because it's made of clear plastic that reveals all the dirt you've collected. What's more, you can easily find objects that you've accidentally vacuumed up without having to tear open a dirty bag.

What should I do if the suction in my Vacuum Cleaner starts to decrease or shut off altogether?

Check the Dirt Arrestor. Before doing so, remember to turn OFF and unplug the Vacuum Cleaner. The Dirt Arrestor is located below the main dirt collection area in the Collection Bin. Look to see that this area is not full. Tip the Collection Bin upside down over a trash can. The two hinged doors of the Dirt Arrestor compartment will swing open and allow any accumulated particles to empty.

What if there is still no suction when I turn on my Vacuum Cleaner?

Once you have fully examined your Dirt Arrestor, check the Cyclone Entrance Hole, and the Inner Tube and wipe away any dirt or lint clinging to the surface. Then open the Inspection Plate and remove any debris that may be plugging up the Air Passageway.

How often will I need to replace the belt?

Not often at all. The Westinghouse WST1500 Vacuum Cleaner uses a special break-free belt. It rarely breaks or needs replacing.

How can I order a Hose Extension or other accessories for my Westinghouse WST1500 Vacuum Cleaner?

Just call our toll free number:
1-800-616-8689 and refer to the
"Accessory/Parts List" in this manual.

What are some of the other accessories I can order for my Westinghouse WST1500 Vacuum Cleaner?

There is a wide range of replacement accessories available. Simply refer to the "Accessory/Parts List" at the back of this manual for a complete list and ordering instructions.

CALL US AT:

1-800-616-8689

or email us at: salton@saltonusa.com

WST1500-1509 SPECIAL EDITION SERIES

ACCESSORY / PARTS LIST

Replacement parts are available, and may be purchased through our Consumer Service Department by calling 1-800-616-8689, Monday through Friday, 9am - 5pm Central Time. You can pay for these parts by using either Visa, Mastercard, Discover, or American Express. Please be ready to give the part number(s) when you call.

Or log into our website to order at: www.eSalton.com

<u>PART #</u>	<u>DESCRIPTION</u>
40018V	Hose Extension
40021	Tool Holder
40015	Crevice Tool
40022V	Floor Nozzle
40023	Dusting Brush
40024	Collection Bin
40032	Collection Bin Cover
40025	Collection Bin Filter
40026	Foam Filter w/ Plastic Post
40027	HEPA Filter Housing Cover
40028	HEPA Air Filter
40029V	Headlight Bulbs (Set of 2)
40030	Belts (Set of 2)



Westinghouse

Wired™

WST1500 SPECIAL EDITION SERIES ACCESSORY ORDER FORM

Please contact us tollfree at: 1-800-616-8689 for All Pricing Information.

To use as a self-mailer, please fold order form as shown on backside, seal with tape and add postage.

PART #	DESCRIPTION		QUANTITY	PRICE EACH	AMOUNT (\$)
40018V	Hose Extension				
40021	Tool Holder				
40015	Crevice Tool				
40022V	Floor Nozzle				
40023	Dusting Brush				
40024	Collection Bin				
40032	Collection Bin Cover				
40025	Collection Bin Filter				
40026	Foam Filter w/ Plastic Post				
40027	Louvered Cover to HEPA Filter Housing				
40028	HEPA Air Filter				
40029V	Headlight Bulbs (Set of 2)				
40030	Belts (Set of 2)				

MAILING LABEL: Please Print

Name _____
 Street: _____
 City: _____ State: _____
 Zip Code _____ Tel: () _____

SUBTOTAL

TAX
(if applicable)

TOTAL

METHOD OF PAYMENT:

- Check / Money Order
- Visa
- American Express
C.I.D.#
- Master Card
- Discover

Credit Card Number:

Expiration Date:

Signature:

CARDHOLDER ADDRESS (if different from mailing address indicated above): Please Print

Name _____
 Street: _____
 City: _____ State: _____
 Zip Code _____ Tel: () _____

Satisfaction guaranteed or full refund price of Accessory within 30 days from date of receipt (less shipping and handling).
 Please contact us at: 1-800-616-8689 for RETURN AUTHORIZATION.
 Enclose Check or Money Order payable to: Salton, Inc.

*Accessories described are subject to availability. Please allow 2 to 4 weeks for processing and delivery.

™ and "You can be sure...if it's Westinghouse" are trademarks of Westinghouse Electric Corporation and used under license by Salton, Inc.
 Wired™ is a trademark of Salton, Inc.

You can be sure...if it's Westinghouse™

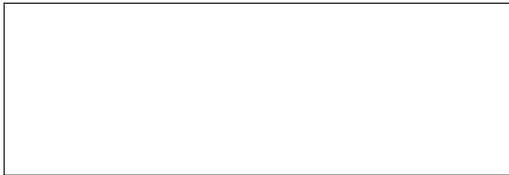

PLACE
STAMP
HERE

Salton, Inc.
1801 North Stadium Blvd.
Columbia, MO 65202

ATTN: WESTINGHOUSE VACUUMS
ORDER PROCESSING DEPARTMENT

LIMITED WARRANTY

One Year Vacuum Cleaner Warranty: This Westinghouse Vacuum Cleaner is warranted to be free from defects in materials and workmanship for a period of (1) year from the original purchase date.

Seven Year Filter Warranty: The HEPA filter in your Westinghouse Vacuum Cleaner is warranted not to become so clogged that it starts to significantly retard air flow for a period of seven (7) years from the original purchase date.

Original Purchaser: This warranty covers only the original consumer purchaser for as long as he or she owns the Westinghouse Vacuum Cleaner.

Warranty Coverage: This warranty is valid only if the purchaser uses the Vacuum Cleaner in accordance with Salton's Operating Instructions. This warranty is void if the Westinghouse Vacuum Cleaner is used for commercial or rental use. This warranty does not apply (i) to normal wear parts that require replacement under normal use. Including but not limited to: rubber parts, hoses, slip belts, bulbs, bumpers and attachments; (ii) to ordinary wear and tear and blockages which occur during use; (iii) if the machine is used to vacuum excessive amounts of plaster dust, sawdust, or fireplace ash; (iv) to Vacuum Cleaners which have been subject to abuse, misuse, negligence or accident; or (v) to damage or defects which were caused by unauthorized or improper use, modification, alteration, service or repair.

This warranty is effective only if the Westinghouse Vacuum Cleaner is purchased and operated in the USA, and does not extend to any units which have been altered or modified

Implied Warranties: ANY IMPLIED WARRANTIES WHICH THE PURCHASER MAY HAVE WITH RESPECT TO THE Westinghouse Vacuum CLEANER ARE LIMITED IN DURATION TO ONE (1) YEAR FROM THE ORIGINAL PURCHASE DATE. ANY IMPLIED WARRANTIES WHICH THE PURCHASER MAY HAVE WITH RESPECT TO THE HEPA FILTER ARE LIMITED IN DURATION TO SEVEN (7) YEARS FROM THE ORIGINAL PURCHASE DATE. Some states do not allow limitations on how long an implied warranty lasts, so the above limitation may not apply to you.

Vacuum Cleaner Warranty Performance: If the Westinghouse Vacuum Cleaner is found to be defective during the warranty period, Salton will, at its option, either repair or replace the Vacuum Cleaner with a reconditioned comparable model, without charge, or refund the purchase price. To get warranty service:

1. Call Salton Consumer Service, toll-free at: 1-800-616-8689 to report the problem.
2. You will be given the name of an Authorized Salton Service Center.
3. Take the Vacuum Cleaner and proof-of-purchase to the designated Authorized Salton Service Center for warranty repairs deemed appropriate by the designated Service Center.
4. If there is no local Authorized Service Center, you may be requested to ship your Vacuum Cleaner (postage prepaid) to a designated Authorized Salton Service Center for warranty repairs. Care must be exercised when the Vacuum Cleaner is shipped, as Salton will not be responsible for warranty repairs to products damaged during transit.

HEPA Filter Warranty Service: If the HEPA Filter becomes so clogged during the warranty period that it starts to significantly retard air flow while you still own the Vacuum Cleaner in which it was installed, Salton will send you a replacement HEPA Filter at no cost. To get warranty service, send the defective Filter postage pre-paid to the Repair Center listed below together with a proof-of-purchase.

Risk During Shipment: We cannot assume responsibility for loss or damage for products shipped for warranty repair. For your protection, carefully package the product for shipment and insure it with the carrier. Be sure to enclose the following items with your appliance: any accessories related to your problem, your full return address and daytime phone number, a note describing the problem you experienced, a copy of your sales receipt or other proof-of-purchase to determine warranty status. C.O.D. shipments cannot be accepted.

To return the product, ship to:
ATTN: Repair Center
Salton, Inc.
708 South Missouri Street
Macon, MO 63552

To contact us, please write to, call, or email:
Consumer Relations Dept.
Salton, Inc.
1801 North Stadium Blvd.
Columbia, MO 65202
1-800-616-8689
E-mail: Salton@Saltonusa.com

Limitation of Remedies: No representative or other person is authorized to assume for Salton any other liability in connection with the sale of our products. There shall be no claims for defects or failure of performance or product failure under any theory of tort, contract or commercial law including, but not limited to negligence, gross negligence, strict liability, breach of warranty and breach of contract. Repair, replacement or refund shall be the sole remedy of the purchaser under this warranty, and in no event shall Salton be liable for any incidental or consequential damages, losses or expenses. Some states do not allow the exclusion or limitation of incidental or consequential damages, so the above limitation or exclusion may not apply to you.

Legal Rights: This warranty gives you specific legal rights, and you may also have other rights which vary from state to state.

™ and "You Can Be Sure...If It's Westinghouse" are trademarks of Westinghouse Electric Corporation and used under license by Salton, Inc. Wired™ is a trademark of Salton, Inc.

For more information on Salton products: visit our website: www.eSalton.com

Free Manuals Download Website

<http://myh66.com>

<http://usermanuals.us>

<http://www.somanuals.com>

<http://www.4manuals.cc>

<http://www.manual-lib.com>

<http://www.404manual.com>

<http://www.luxmanual.com>

<http://aubethermostatmanual.com>

Golf course search by state

<http://golfingnear.com>

Email search by domain

<http://emailbydomain.com>

Auto manuals search

<http://auto.somanuals.com>

TV manuals search

<http://tv.somanuals.com>