

VENTED KITCHEN RANGE HOOD FOR 120 V. OPERATION



KITCHEN
RANGE HOOD
MODEL

RH8930XLS

INSTALLATION INSTRUCTIONS

READ AND SAVE THESE INSTRUCTIONS

Before you begin, read the following instructions completely and carefully. If followed, they will simplify the installation job.

IMPORTANT: OBSERVE ALL GOVERNING CODES AND ORDINANCES

SAVE THESE INSTRUCTIONS FOR THE LOCAL ELECTRICAL INSPECTOR'S USE

This unit can be vented vertically through upper cabinets or horizontally through an outside wall. A typical vertical installation is shown in Figure 1. A typical horizontal installation is shown in Figure 2. For proper ventilation when used with an indoor electric grill, see page 4 for guidelines for proper duct sizing. **Improper duct sizing or installation of restrictive roof jacks can reduce air moving capacity and provide inadequate ventilation for an indoor electric grill.**

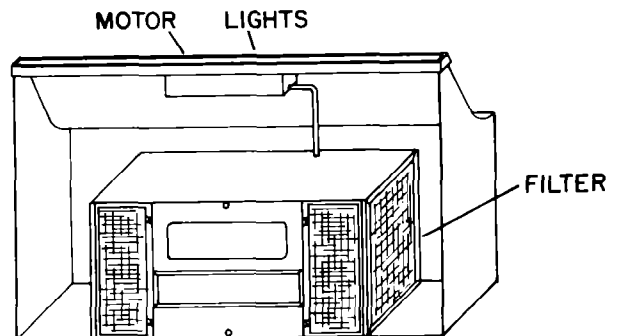

For most efficient smoke removal, the top of the hood should be approximately 66 inches (167.6 cm) from the floor.

TOOLS AND MATERIALS REQUIRED

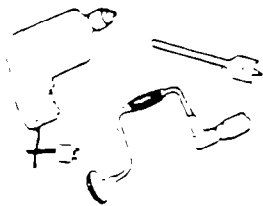

- Drill, electric or ratchet drive, with 1-1/4" wood bit (to drill an access hole in the cabinet or kitchen wall for the electric power line.)



- One common head screwdriver (to secure hood mounting screws to the cabinet and hood sheet metal parts).

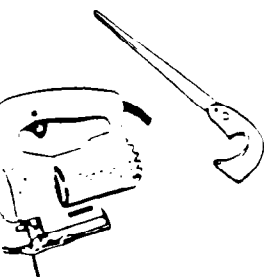

- Pliers (for opening knockouts).
- Pencil, ruler and level for marking cabinet locations.
- Saber saw or keyhole saw for cutting the wall or cabinet openings.

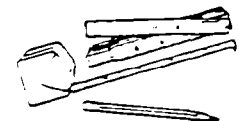
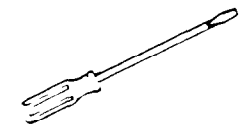

- Caulking, metal snips, duct tape, ducts (with elbow and transition, if necessary) and wall cap or roof cap, as required.

RANGE HOOD BLOWER ORIENTATION

NOTE: Before reinstalling the blower Assembly, check the damper for free operation. Open the damper blade and check for any restrictions in the duct system. Check installation instructions for proper duct sizing.

Correct Blower orientation is imperative. Incorrect installation will drastically cut air flow and cause Blower to run at maximum RPM regardless of motor speed control setting.

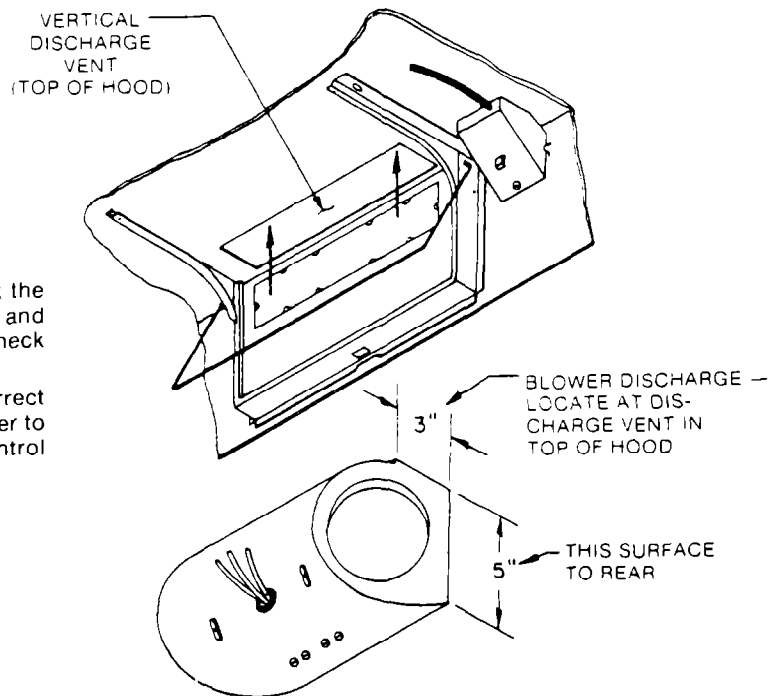

FIGURE 7
VERTICAL DISCHARGE

VERTICAL DISCHARGE:

1. Figure 7 shows the proper Blower Assembly orientation for vertical discharge.
2. From the blower position shown in Figure 7, lift the Blower Assembly vertically into mounting position.
3. The 3" blower discharge surface should now be flush against top of hood. This will allow proper air flow from the blower through the top vent. (The wider 5" surface will be to the rear.)

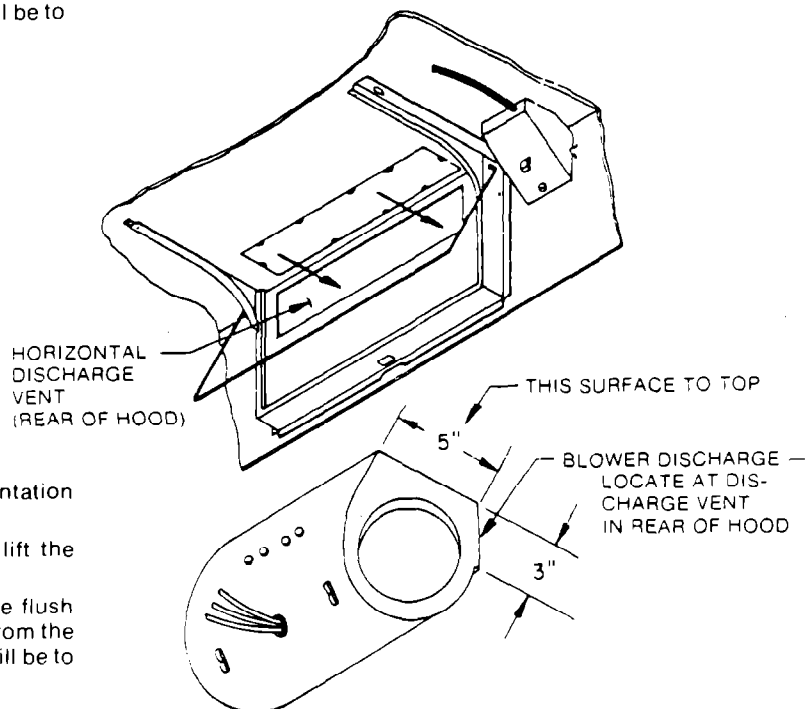

FIGURE 8
HORIZONTAL DISCHARGE

HORIZONTAL DISCHARGE:

1. Figure 8 shows the proper Blower Assembly orientation for horizontal discharge.
2. From the Blower position shown in Figure 8, lift the blower Assembly vertically into position.
3. The 3" Blower discharge surface should now be flush against rear of hood. This will allow proper air flow from the Blower through the rear vent. (the wider 5" surface will be to the top.)

Guideline to Proper Duct Sizing for Ventilating An Indoor Electric Grill

These Guidelines are to insure adequate ventilation for an indoor Electric Grill. Indoor electric grills produce more smoke than normal cooking and requires at least 410 CFM to provide adequate ventilation. Less stringent ventilating requirements can deviate from these recommendations.

HORIZONTAL VENTING

Figure two on page two shows a direct discharge to the outside through a wall rain cap. Due to the lower CFM rating in this venting position, duct must be limited to a maximum of 2 feet of 3/4 x 10 inch duct capped with a wall rain cap with a free discharge area of at least 66 inches square. There should be no bends in the connecting duct between the hood and the wall rain cap.

Figure 9 shows an installation requiring more duct length. A transition to round is used as close to the hood as possible to eliminate the restriction caused by the 3/4 x 10 duct. 45° bends should be used instead of 90° bends wherever possible.

VERTICAL VENTING:

Figure one on page two shows an installation using 3 feet of 3/4 x 10 inch duct terminating in a roof rain cap. In table one we see that 3 feet of 3/4 x 10 inch duct is the maximum length of 3/4 x 10 inch duct recommended.

For example, if the straight lengths of duct in Fig 9 total 9 ft. the elbow is 45° and the roof rain cap has 113 in² free area, choose the duct size required. The 45° elbow can be approximated by dividing the equivalent duct lengths in Table 2 by two.

Since we already have 9 ft. of straight duct, Table 1 tells us that 7" dia. is too small. So we try 8" dia.

- 9 ft. Straight Duct
- 6 ft. Equivalent straight length of 45° elbow (8" Dia.)
- 15 ft.

Fifteen feet is over the maximum of 13 ft. for 8" dia. duct, so 8" duct is too small.

Move to 9" dia. duct and run through the calculations again.

- 9 ft. Straight Duct.
- 7 ft. Equivalent straight length of 9" dia. duct for 45° elbow.
- 16 ft.

Sixteen feet is under the maximum of 25 ft. for 9" dia. duct, so 9" duct is a good choice.

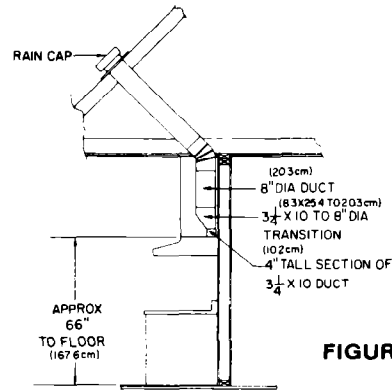



FIGURE 9

TABLE 1
Vertical Venting

Duct Size	3/4 x 10"	7" dia.	8" dia.	9" dia.	10" dia.
Max. Duct Length (Feet)	3	7	13	25	40

Table 1 shows the maximum length of duct to be used in conjunction with a roof rain cap having a free area of 113 in².

TABLE 2

	Duct Size	Equivalent length of straight duct of same dia.
 90° Elbow	7" dia.	11 ft.
	8" dia.	12 ft.
	9" dia.	14 ft.
	10" dia.	16 ft.

CFM vs. DUCT LENGTH
Equivalent Duct Length (ft.)

Static Pressure	CFM	3-1/4 x 10 Rect.	7" dia.	8" dia.	9" dia.
.06	460	4	8.5	17	30
.10	440	7	16.0	31	55.5
.15	417	12	25.0	50	88
.20	390	18	40	77	142
.25	355	26	61	104	
.275	330	34	73	145	
.30	250	65	136		
.35	180	140			

NOTE: The above table is based on vertical discharge. The values in this table are for duct length only and do not account for static pressure loss through roof mounted rain caps.

OPERATION AND CARE OF UNIT

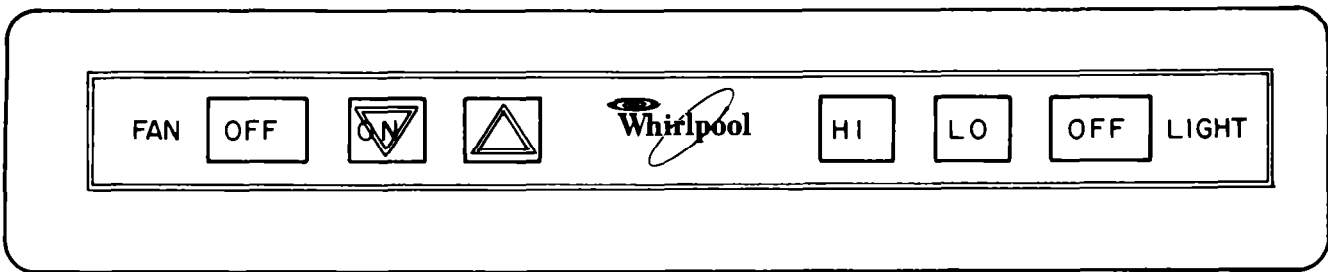

FAN AND LIGHT CONTROL PANEL

FAN:

For best results, turn the fan on at the beginning of cooking and allow it to run until all smoke and odors are removed from the room.

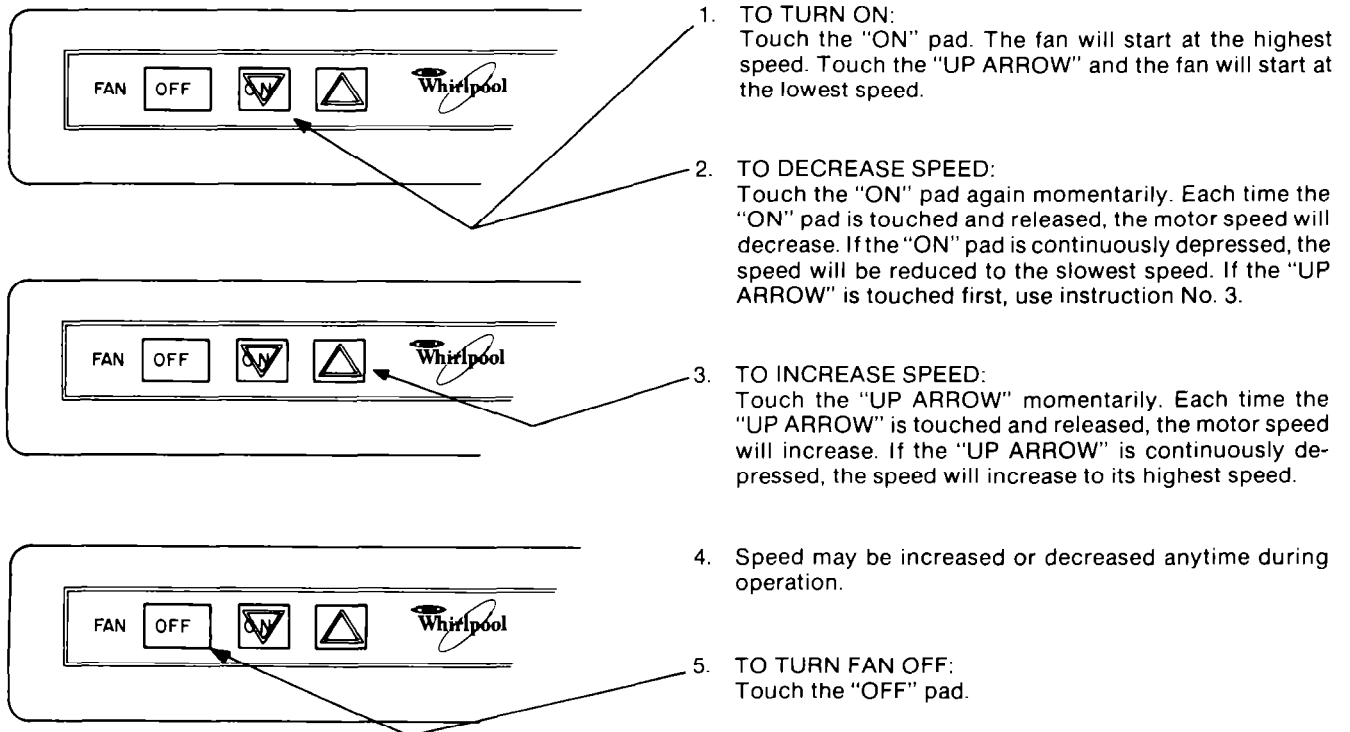

LIGHT:

Do not use bulb larger than 60 Watts.

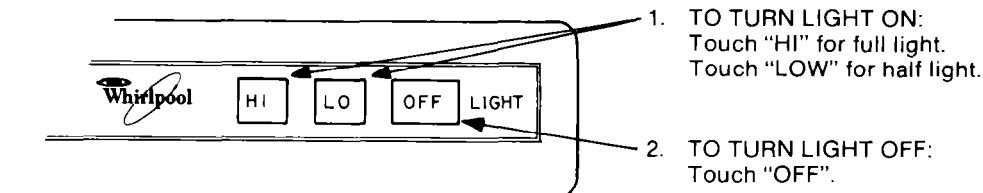

FILTER:

For best results, remove and clean often. The filter may be placed in the dishwasher or washed in hot sudsy water.

EXTERIOR SURFACES:

Clean the range hood with a mild detergent and soft cloth. Do not use abrasive cleansers or soapy steel wool pads.

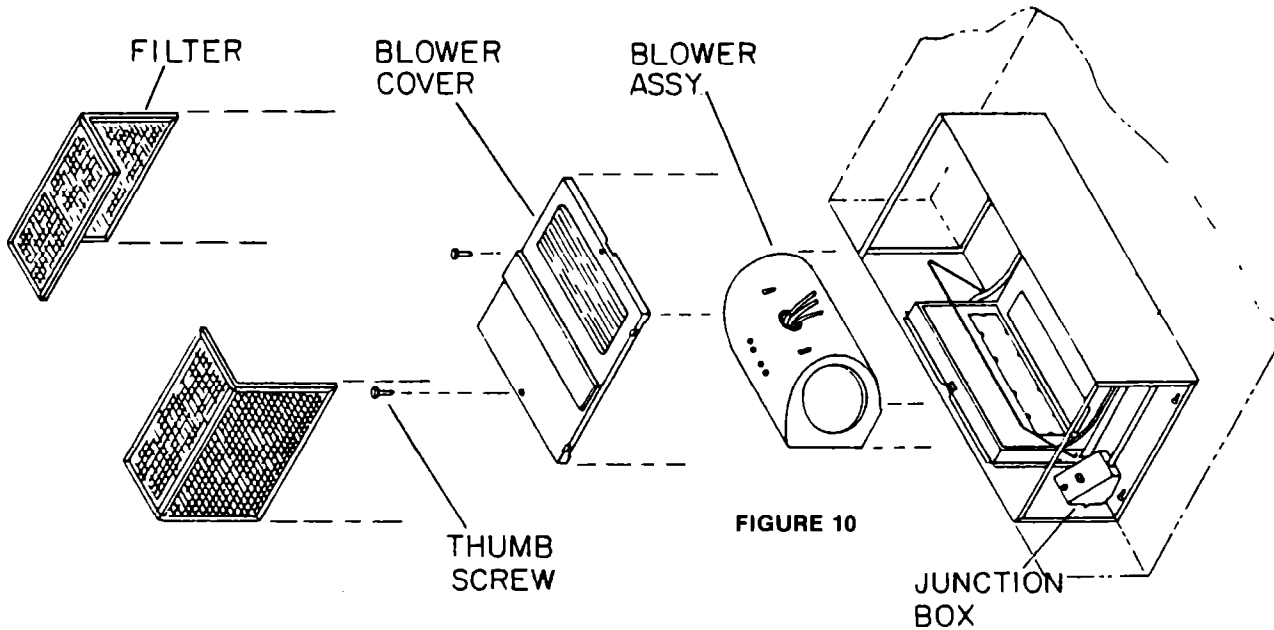

FIGURE 10

EXHAUST UNIT ASSEMBLY

If you need service or assistance, we suggest you follow these four steps:

1. Before calling for assistance...

Performance problems often result from little things you can find and fix yourself without tools of any kind.

If nothing operates:

- Have you checked the main fuse or circuit breaker box?

2. If you need assistance...

Call the Whirlpool COOL-LINE® service assistance telephone number. Dial free from:

Continental U.S. (800) 253-1301
 Michigan (800) 632-2243
 Alaska & Hawaii (800) 253-1121

and talk with one of our trained Consultants. The Consultant can instruct you in how to obtain satisfactory operation from your appliance or, if service is necessary, recommend a qualified service company in your area.



3. If you need service...



Whirlpool has a nationwide network of franchised TECH-CARE® Service Companies. TECH-CARE service technicians are trained to fulfill the product warranty and provide after-

warranty service anywhere in the United States. To locate TECH-CARE service in your area, call our COOL-LINE service assistance telephone number (see Step 2) or look in your telephone directory Yellow Pages under:

APPLIANCES—HOUSEHOLD
 MAJOR—SERVICE & REPAIR

WHIRLPOOL APPLIANCES
 FRANCHISED TECH-CARE SERVICE
 SERVICE COMPANIES
 XYZ SERVICE CO.
 123 Maple 999-9999

OR

ELECTRICAL APPLIANCES—
 MAJOR—REPAIRING & PARTS

WHIRLPOOL APPLIANCES
 FRANCHISED TECH-CARE SERVICE
 SERVICE COMPANIES
 XYZ SERVICE CO.
 123 Maple 999-9999

OR

WASHING MACHINES, DRYERS
 & IRONERS—SERVICING

WHIRLPOOL APPLIANCES
 FRANCHISED TECH-CARE SERVICE
 SERVICE COMPANIES
 XYZ SERVICE CO.
 123 Maple 999-9999

4. If you have a problem...

Call our COOL-LINE service assistance telephone number (see Step 2) and talk with one of our Consultants, or if you prefer, write to:

Mr. Guy Turner, Vice President
 Whirlpool Corporation
 Administrative Center
 2000 US-33 North
 Benton Harbor, MI 49022

If you must call or write, please provide model number, serial number, date of purchase, and a complete description of the problem. This information is needed in order to better respond to your request for assistance.

TROUBLE SHOOTING PROCEDURE

If entire unit is not working, proceed as follows:

1. Check circuit breaker box to insure that breaker for hood is not tripped.
2. Remove printed circuit board enclosure cover by removing two screws securing the cover. (See Figure 1.)

CAUTION: SHOCK HAZARD

SOME CIRCUIT BOARD COMPONENTS (INCLUDING HEAT SINKS) ARE NOT ISOLATED FROM THE AC POWER LINE.

3. Disengage five pin connector from P. C. board and check for 115VAC (nominal) AC line voltage between the black wire socket (end socket) and white wire socket (center socket) by inserting VOM probes into sockets.
4. If voltage is not present, proceed as follows:
 - a. Turn off power at breaker box.
 - b. Check connections in rear power entry box. (See Fig. 1.)
 - (1) Push in filter retaining tabs and remove filter from wiring compartment.
 - (2) Remove cover retaining screws and cover.
 - (3) Remove wiring box covers (2).
 - c. Check continuity of wires from wire nut connections to P. C. board sockets by inserting one meter probe in wire nut connection and the other probe in respective socket connector.
 - d. Repair or replace as required, restore power to unit and again check for voltage at P. C. board connector.
5. If the fan or light still does not operate, proceed as follows:
 - a. With five pin connector plugged into board and light and/or fan turned on, check output of the red (light) and blue (fan) wires in the five pin connector by inserting one probe of the meter in the back of the socket at the respective wire connection (red or blue) and the other probe in the back of the socket at the black wire connection.
 - (1) Reading for red wire output should be 50-65 VAC if the light is on "Lo" or 100-125 VAC if the light is on "Hi".
 - (2) Reading for blue wire output should be between 72 VAC and the line voltage reading, depending upon fan speed setting.
 - b. If output readings are correct, problem is in the wiring from plug to devices (fan and light) or in the devices themselves. (Bad socket or bulb and/or defective fan motor.)
 - c. If outputs are not correct, problem is in the circuit board or membrane switch. (See Page 2.)

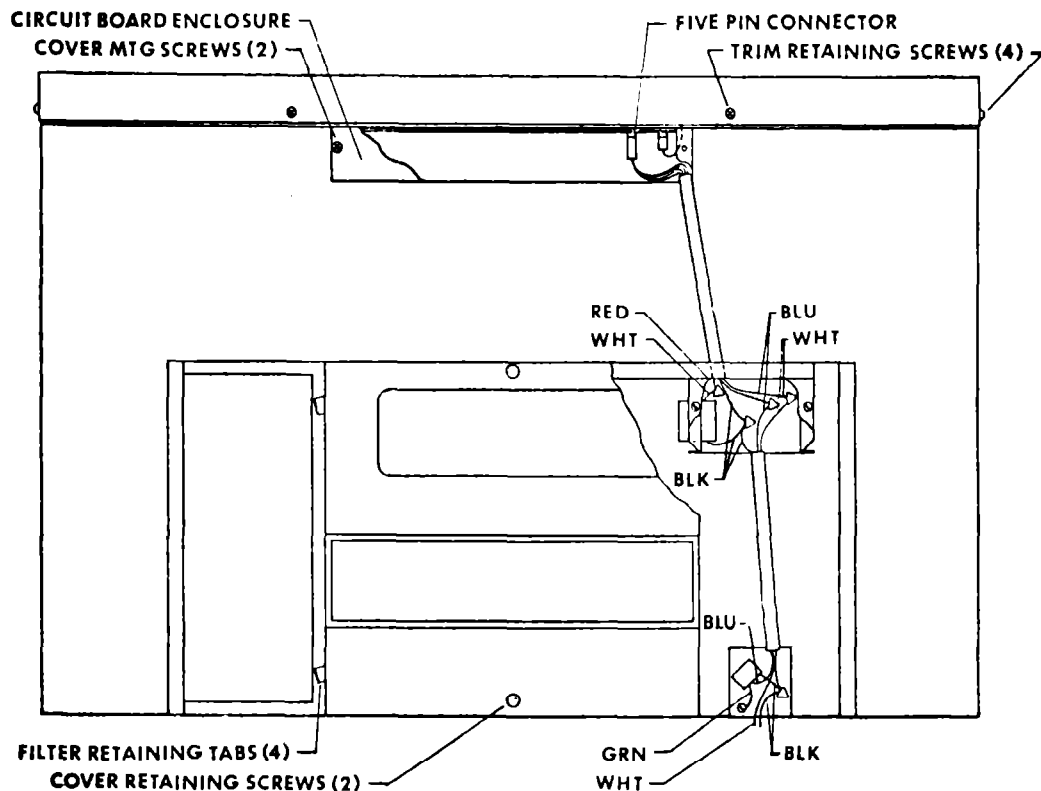

FIG. 1 INSIDE OF HOOD

(1)

6. Replace the control circuit board (See Figure 2):
 - a. Remove five pin cable connector.
 - b. Flip up tab on switch flex tail connector and remove tail from connector.
 - c. Remove three screws securing board to the enclosure and remove board.
 - d. Replace with new circuit board and re-assemble by reversing above procedure. Be sure that the switch flex tail is inserted far enough into its connector that the locking teeth on the connector tab engage the slots in the switch tail.
7. If unit still does not operate, check membrane switch by removing switch tail from connector and inserting tail of a new unattached membrane switch in connector from P. C. board side of hood and secure with tab. Insure that tail is oriented same as tail on attached switch. Operate switch and if unit operates, replace attached switch with new switch. To replace membrane switch, proceed as follows:
 - a. Release switch flex tail from P. C. board connector.
 - b. Remove front trim by removing screws securing trim to hood. Be careful not to scratch or otherwise damage trim.
 - c. Remove switch by carefully running a sharp thin knife or razor blade under edge of switch to break adhesive loose at one end of switch. Pull switch with steady outward pressure.
 - d. Replace switch by removing paper backing, inserting flex tail in hood front slot and CAREFULLY aligning switch before allowing adhesive to secure switch to front panel. Remove switch front protective coating by carefully peeling off of switch.
 - e. Insert flex tail into circuit board connector and secure with locking tab.
 - f. Operate unit and if it works properly, replace trim, original circuit board, and circuit board enclosure cover.

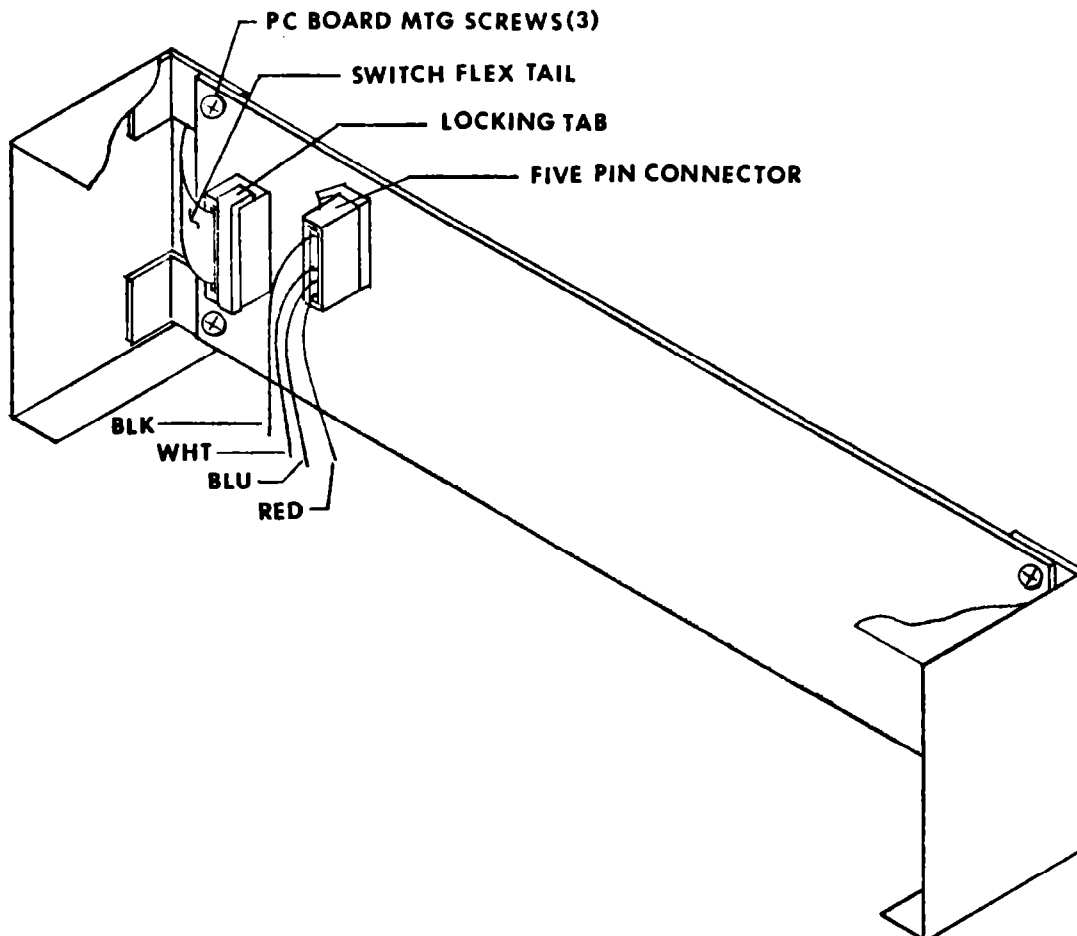

FIG. 2 P C BOARD REMOVAL

Free Manuals Download Website

<http://myh66.com>

<http://usermanuals.us>

<http://www.somanuals.com>

<http://www.4manuals.cc>

<http://www.manual-lib.com>

<http://www.404manual.com>

<http://www.luxmanual.com>

<http://aubethermostatmanual.com>

Golf course search by state

<http://golfingnear.com>

Email search by domain

<http://emailbydomain.com>

Auto manuals search

<http://auto.somanuals.com>

TV manuals search

<http://tv.somanuals.com>