

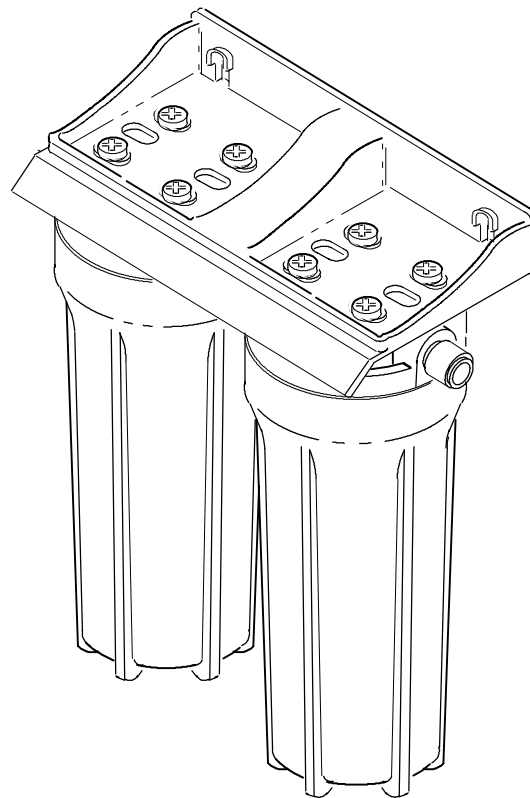

Model WHED10

How to install, operate and maintain your Undersink Drinking Water Filter System



Do not return unit to store

If you have questions or concerns when installing, operating or maintaining your Undersink Drinking Water Filter System call our toll free number:

1-866-986-3223

Monday - Friday, 8 am - 9 pm EST

System tested and certified by NSF International against NSF/ANSI Standards 42 & 53. See performance data sheet for details.



7279066 (Rev. B 9/21/05)
Product No. 8578160

Installation and Operation Manual

Table of Contents

Parts of the System / Typical Installation Drawing / Tools and Materials Needed	4
Drinking Water Filter System Installation	5
Installing Supply Fitting	5
Installing Faucet	5
Installing Filter Cartridge	7
Filter Cartridge Life / Replacement	7
Repair Parts	10

Before You Start

▼ Read all steps and guides carefully before installing and using your undersink drinking water filter system. Follow all steps exactly to correctly install. Reading this manual will also help you to get all the benefits from the undersink drinking water filter system.

▼ **Do not use with water that is microbiologically unsafe or of unknown quality without adequate disinfection before or after the system. This system is certified for cyst reduction and may be used on disinfected waters that may contain filterable cysts.**

▼ **All plumbing should be done in accordance with local codes and requirements. In Massachusetts, plumbing code 248 CMR 3.00 and 10.00 shall be adhered to. Consult with your licensed plumber.**

▼ The undersink drinking water filter system works on water pressures of 30 psi (minimum) to 125 psi (maximum). If your house water pressure is over the maximum, install a pressure reducing valve in the water supply pipe to the filter system.

▼ Do not install the undersink drinking water filter system outside, or in extreme hot or cold temperatures. Temperature of the water supply to the undersink drinking water filter system must be between 40°F and 100°F. Do not install on hot water.

Min. - Max. Supply Water Pressure	30 - 125 psi (207 - 862 kPa)
Min. - Max. Supply Water Temperature	40 - 100 °F (4 - 38 °C)
Inlet - Outlet	3/8" quick connect fittings and tubing included

Parts of the System

- filter system assembly including mounting bracket and screws
- water supply fitting
- filtered water faucet for sink or countertop mounting
- 3/8" tube benders
- 3/8" tubing to make all needed connections

Materials and Tools Needed

NOTE: Gather the required tools before starting installation. Read and follow the instructions provided with any tools listed here.

IMPORTANT: To avoid damaging the sink, consult a qualified plumber or installer for drilling procedures in porcelain or stainless steel.

- slotted and Phillips screwdrivers
- pliers and adjustable jaw wrench
- tubing cutter
- electric drill and 1-3/8" drill bit if mounting hole is needed for the faucet

Typical Undersink Installation

Locate the water filter housing on the cold water supply pipe, under the kitchen and/or bathroom sink, to filter the cold drinking water. Refer to the following drawing.

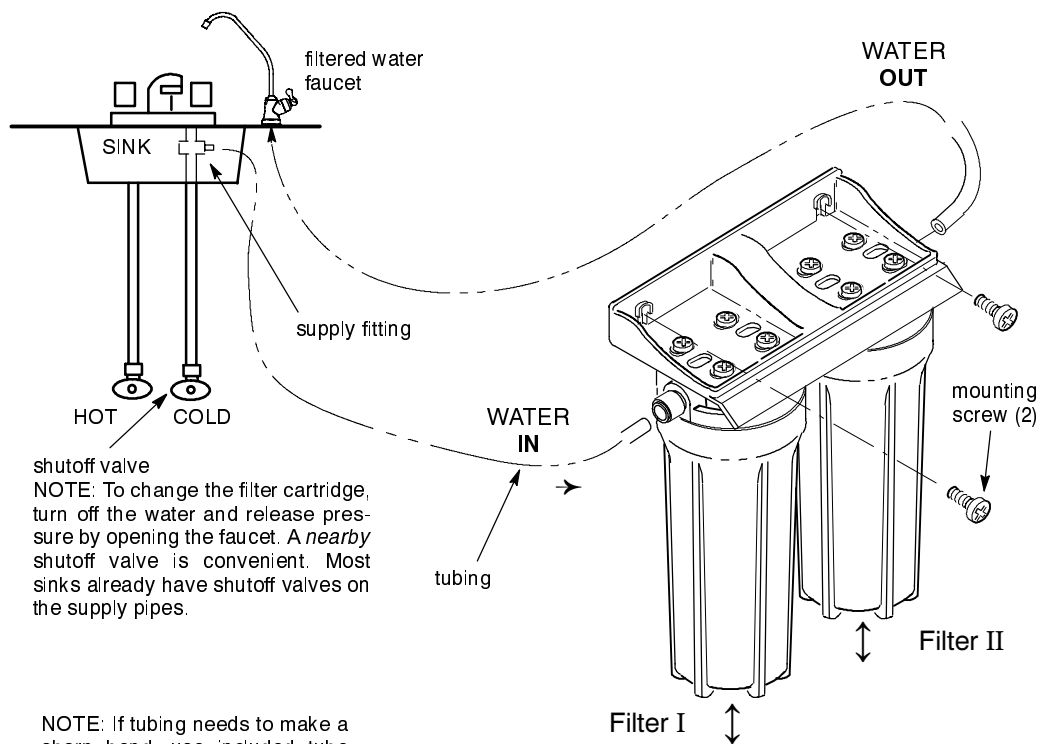

NOTE: If tubing needs to make a sharp bend, use included tube benders to prevent kinking.

NOTE: Allow a minimum space of 1-1/2" under the system for removing the housings (to change the cartridges).

Figure 1

Installation Steps

Step 1 – Cold Water Supply Fitting

Check and comply with local plumbing codes as you plan, then install a cold feed (supply) water fitting. The fitting must provide a leak-tight connection to the water filter 3/8" tubing. A typical connection using the included water supply fitting is shown in Figure 2A. An optional connection using standard plumbing fittings (not included) is shown in Figure 2B.

Cold Water Supply Fitting

1. Close the house main water shutoff valve and open faucets to drain water from the sink cold water pipe.
2. Remove nut that connects the cold water faucet to cold water plumbing.
3. Thread water supply fitting onto pipe and reconnect nut to bottom of fitting.

Optional Pipe Fittings (compression type shown)

NOTE: Be sure to turn off the water supply and open a faucet to drain the pipe.

Install a fitting on the cold water pipe to adapt 3/8" OD tubing. A typical connection is shown in Figure 2B. If threaded fittings are used, be sure to use pipe joint compound or Teflon tape on outside threads.

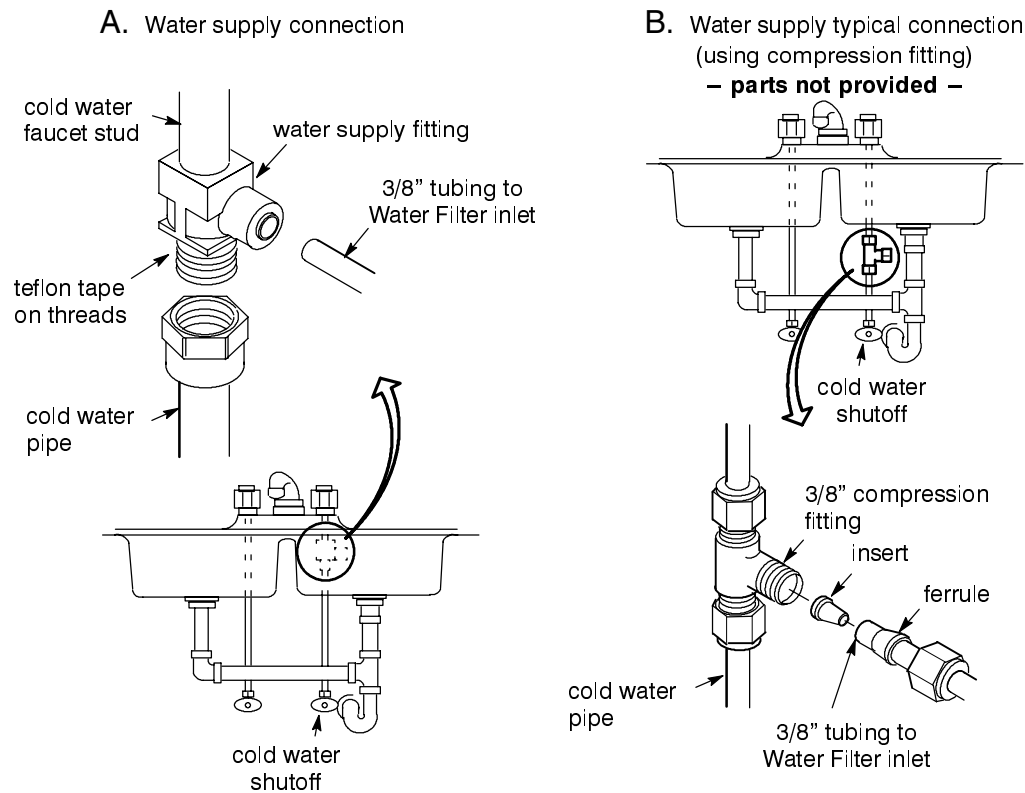

Figure 2

Step 2 – Make Hole For Filtered Water Faucet

IMPORTANT: To avoid damaging the sink, consult a qualified plumber or installer for drilling procedures in porcelain or stainless steel. Special drill bits are made for this.

Select one of the following places to install the faucet. Be sure there's room underneath so you can make the needed connections.

- In an existing sink spray attachment hole
 - Drill a hole in the sink top.
 - Drill a hole in the countertop next to the sink.
1. If drilling is needed make a 1-3/8" dia. (minimum) hole for the faucet.

Step 3 – Install Faucet

1. Slide the toggle bolts through the mounting hole. Tighten the screws to secure the base flat on the mounting surface.
2. Feed a length of 3/8" tubing through the hole and connect to the quick connect fitting on the bottom of the faucet.
3. Move the faucet down onto the base. Turn 1/4 clockwise to attach the faucet to the base.

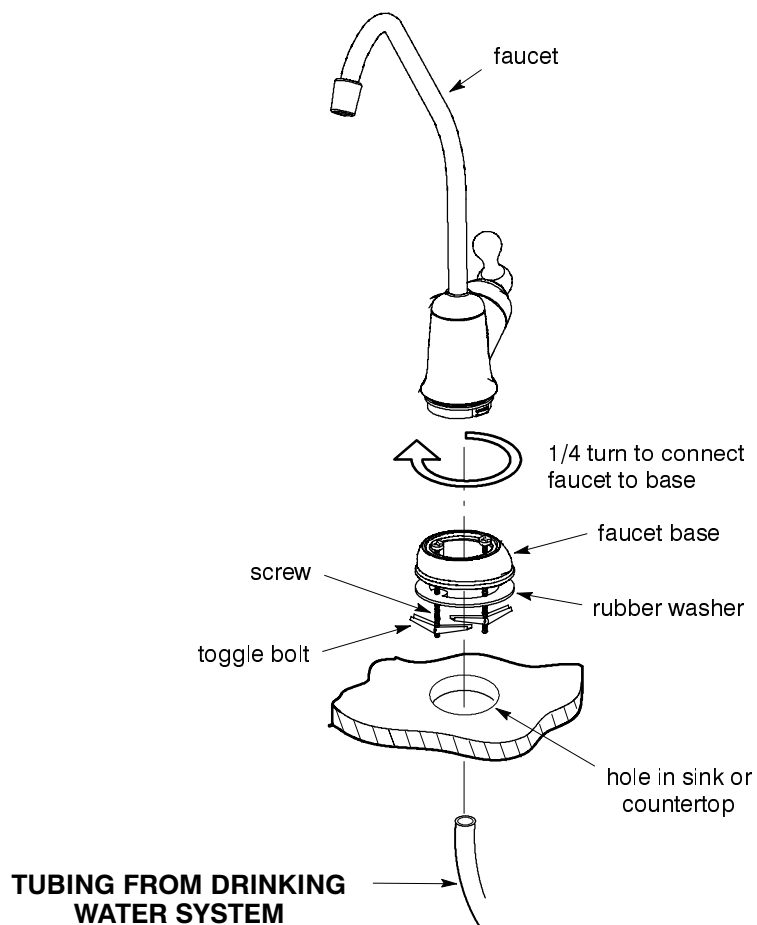

Figure 3

Step 4 – Make Tubing Connections

1. Allowing some slack, measure and cut a length of 3/8" tubing to connect between the supply fitting and the filter system inlet. Cut the ends of the tubing square.
2. Insert tubing all the way into the supply fitting and inlet fitting. Pull on the tubing to be sure that it's held firmly in the fittings.
3. Repeat steps 1 and 2 to connect tubing from the faucet to the filter system outlet.

Tubing Connection (all push-in fitting locations):

This system includes push-in fittings for quick tubing connections. If working with the fittings, do the following.

Connect Tubing:

1. Use a sharp cutter or knife to cut the end of tubing square.
2. Inspect the end (about 1") of the tubing to be sure there are no nicks, scratches or other rough spots. If needed cut the tubing again until tubing is round and smooth with no cuts, nicks or flat spots.
3. Push tubing through the collet and all the way into the fitting. Full engagement is 3/4" length of tube into the fitting.

If tubing other than supplied with the system is used, be sure it is of exact size and roundness with a smooth surface.

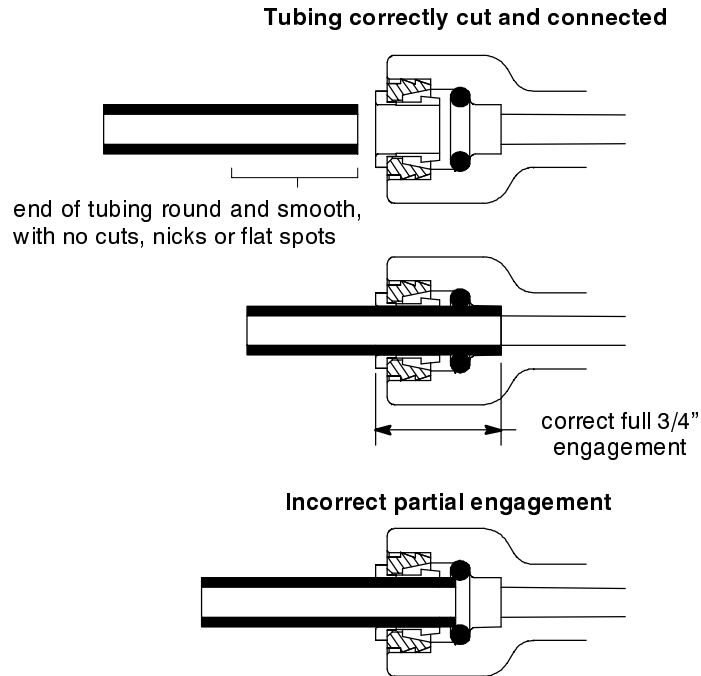

Figure 4

Disconnect Tubing (if needed):

1. Push the collet inward and hold with a finger while pulling the tubing out.

collet (depress to remove tubing)

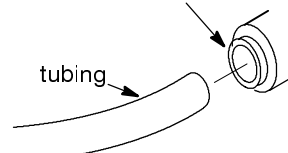

Figure 5

Filter Cartridges

Filter Cartridge Life

Several variables determine how long a cartridge will last. These include:

1. How much water you use, and
2. How much sediment, taste and/or odor, or other unwanted substance, is in the water.

Use the following information as a guide. However, no matter which type of cartridge you are using, you will know it is time to replace it when you *first* notice the return of the unwanted substance in your water. As a rule of thumb, an average family of four will use 1000 gallons of filtered water every 6 months.

Whirlpool Undersink Drinking Water Filter system model WHED10 with replacement elements WHCF-GD05 and WHCF-DB1 has been tested and certified by NSF International for the reduction of protozoan cysts and chlorine. The rated capacity for this system is 1000 gallons (3785 liters) at a rated service flow of 0.6 gpm (gallons per minute).

NOTE: A taste and odor cartridge contains activated carbon, a black powder. When new, open the filtered water faucet and allow fine, carbon particles to purge from the cartridge. Close the faucet when you no longer see the “fines” (carbon particulates) in the filtered water, or approximately 30 minutes.

Filter Cartridge Replacement

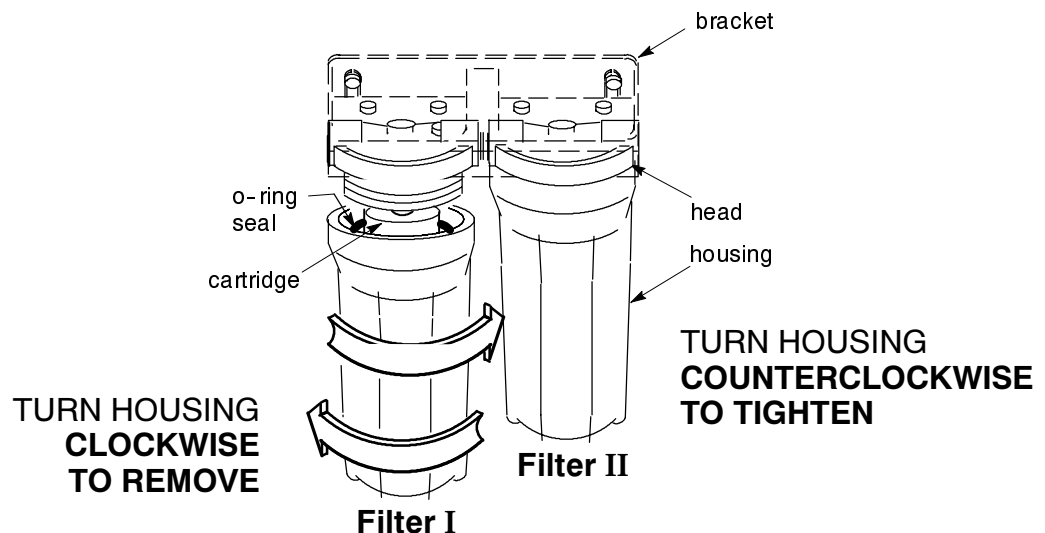

Figure 6

IMPORTANT: Do not remove housings with water pressure in the filter system.

1. Close the water supply shut-off valve to the filter. Open the filtered water faucet to relieve pressure in the system.
2. Turn the housing off of the filter head, to the left, or clockwise. Be careful, the housing is full of water. Do not lose the large o-ring seal.

NOTE: Filter wrenches are sold separately, if needed.

3. Be sure the inside of the housing is clean. Use hot, soapy water and rinse thoroughly.

NOTE: Always use soap and water to clean the Undersink Drinking Water Filter System. Do not use vinegar or other acid based cleaners on this system as they will degrade some of the system parts.

-
4. Remove the wrapper from the new filter cartridge and insert the filter cartridge in the housing. Observe markings on the cartridge, or on the wrapper for proper installation of the replacement filter.
 5. Lightly lubricate the o-ring seal in the housing with silicone grease or petroleum jelly. Be sure it is fully seated in its groove.
 6. Hold the housing up to the filter head aligning the center hole in the cartridge with the protrusion on the bottom of the head.

NOTE: If the housing will not tighten up to the head you may have the cartridge in upside down. Take the cartridge out and check for correct orientation.

7. Being careful not to cross-thread, turn (counterclockwise) the housing onto the filter head and tighten securely.
8. Repeat steps 2 through 7 at the other filter.
9. Open the filtered water faucet. Then slowly open the water supply valve and allow the filter housing to fill.
10. Close the filtered water faucet. Check for leaks between the housing and the head.
11. If leaks occur, turn off the water supply and open the filtered water faucet to depressurize the filter. Then disassemble the filter and check the o-ring for cuts, flat spots, etc., and sealing surfaces for foreign material. Clean the o-ring and lubricate with silicone grease or Vaseline. Carefully press into the groove in the housing.
12. Flush system for 30 minutes.

Warranty

ONE YEAR LIMITED WARRANTY ON UNDERSINK DRINKING WATER FILTER SYSTEM (except filter cartridges)

Warrantor: Ecodyne Water Systems Inc., 1890 Woodlane Drive, Woodbury, MN 55125

Warrantor guarantees, to the original owner, that the Undersink Drinking Water Filter System, when installed and maintained in accordance with the instructions, will be free from defects in materials and workmanship for a period of one year from date of installation.

If, within the first year, a part proves, after inspection, to be defective, Warrantor will, at its sole option, either replace or repair the part without charge except normal shipping and installation charges. Labor to maintain the equipment is not part of the warranty. Filters, which are expendable, are not covered by the warranty.

TO OBTAIN WARRANTY PARTS, SIMPLY CALL 1-866-986-3223, Monday - Friday, 8 am - 9 pm EST, for assistance. This warranty applies only while this product is in use in the United States.

General Provisions

The above warranties are effective provided the Undersink Drinking Water Filter System is operated at water pressures not exceeding 125 psi, and at water temperatures not exceeding 100°F; provided further that the Undersink Drinking Water Filter System is not subject to abuse, misuse, alteration, neglect, freezing, accident or negligence; and provided further that the Undersink Drinking Water Filter System is not damaged as the result of any unusual force of nature such as, but not limited to, flood, hurricane, tornado or earthquake.

Warrantor is excused if failure to perform its warranty obligations is the result of strikes, government regulation, materials shortages, or other circumstances beyond its control.

*THERE ARE NO WARRANTIES ON THE UNDERSINK DRINKING WATER FILTER SYSTEM BEYOND THOSE SPECIFICALLY DESCRIBED ABOVE. ALL IMPLIED WARRANTIES, INCLUDING ANY IMPLIED WARRANTY OF MERCHANTABILITY OR OF FITNESS FOR A PARTICULAR PURPOSE, ARE DISCLAIMED TO THE EXTENT THEY MIGHT EXTEND BEYOND THE ABOVE PERIODS. THE SOLE OBLIGATION OF WARRANTOR UNDER THESE WARRANTIES IS TO REPLACE OR REPAIR THE COMPONENT OR PART WHICH PROVES TO BE DEFECTIVE WITHIN THE SPECIFIED TIME PERIOD, AND WARRANTOR IS NOT LIABLE FOR CONSEQUENTIAL OR INCIDENTAL DAMAGES. NO WARRANTOR DEALER, AGENT, REPRESENTATIVE, OR OTHER PERSON IS AUTHORIZED TO EXTEND OR EXPAND THE WARRANTIES EXPRESSLY DESCRIBED ABOVE.

Some states do not allow limitations on how long an implied warranty lasts or exclusions or limitations of incidental or consequential damage, so the limitations and exclusions in this warranty may not apply to you. This warranty gives you specific legal rights, and you may have other rights which vary from state to state. This warranty applies to consumer-owned installations only.

® Registered trademark/TM Trademark of Whirlpool, USA, used under license.

© 2004 Whirlpool Corporation. All rights reserved.

REPAIR PARTS

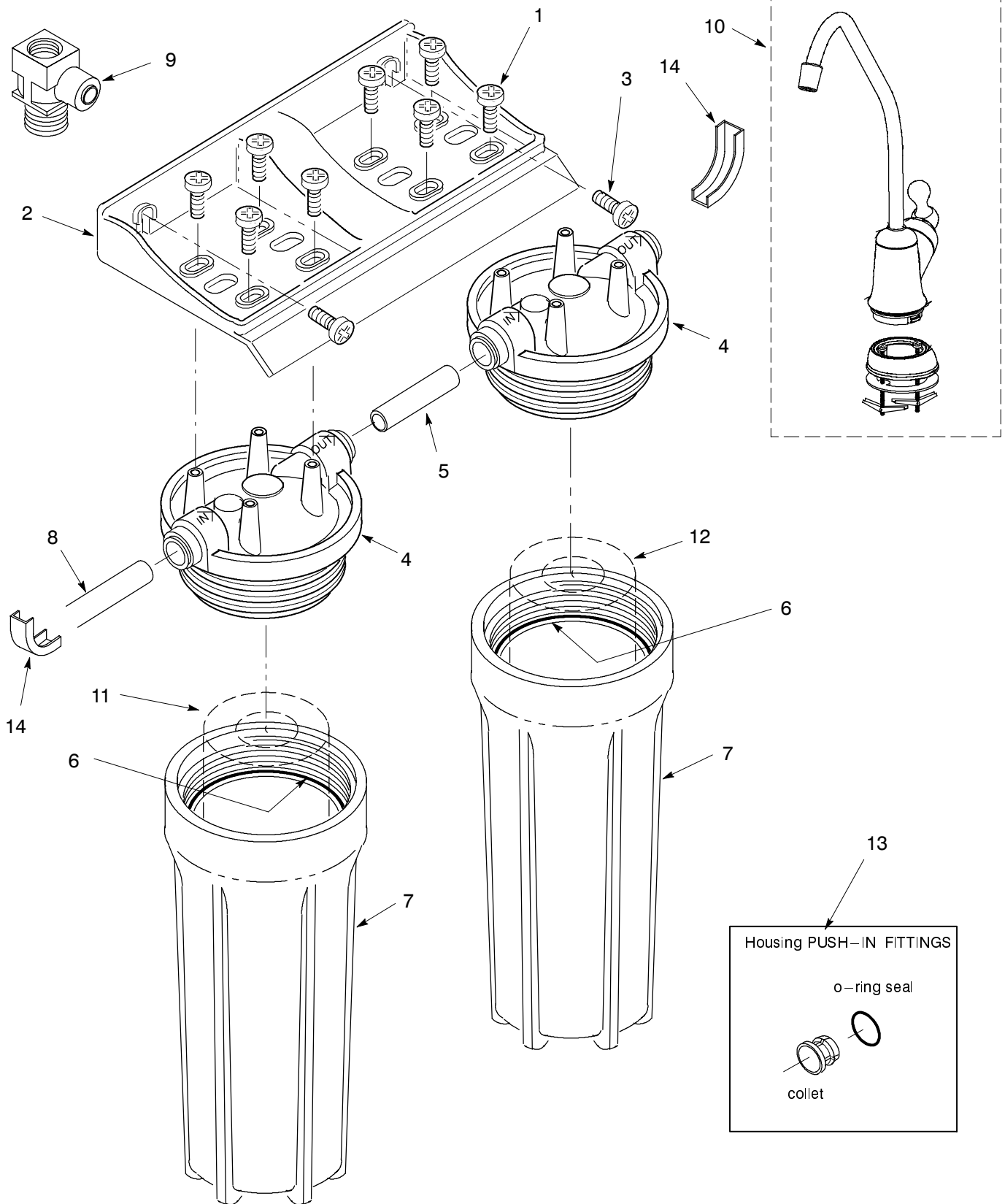

REPAIR PARTS LIST

KEY NO.	PART NO.	DESCRIPTION
1	7160453	Screw, #10 - 14 x 3/4" (8 req'd)
2	7279032	Mounting Bracket
3	9006053	Screw, #10 - 14 x 1-1/4" (2 req'd)
4	7256864	Head (2 req.)
5	7279040	Tubing, cut
6	7170246	O-ring, 3-3/8" I.D. x 3-5/8" O.D. (2 req'd)
7	7205596	Housing (2 req'd)
8	7168435	Tubing, 3/8" x 72"
9	7228536	Tee, Feed Adaptor
10	7278840	Faucet
11	WHCF-GD05	Replacement Element, Sediment
12	WHCF-DB1	Replacement Element, Cyst, Taste & Odor
13	7209574	Push-In Fitting Kit, 3/8"
14	7273565	Flow Bend, 3/8" (2 req'd)
◆	7279066	Owners Manual

◆ not illustrated

For repair parts call 1-866-986-3223

Manufactured and warranted by
Ecodyne Water Systems LLC
1890 Woodlane Drive
Woodbury, MN 55125

Free Manuals Download Website

<http://myh66.com>

<http://usermanuals.us>

<http://www.somanuals.com>

<http://www.4manuals.cc>

<http://www.manual-lib.com>

<http://www.404manual.com>

<http://www.luxmanual.com>

<http://aubethermostatmanual.com>

Golf course search by state

<http://golfingnear.com>

Email search by domain

<http://emailbydomain.com>

Auto manuals search

<http://auto.somanuals.com>

TV manuals search

<http://tv.somanuals.com>