

OWNER'S MANUAL 1610/1630 RADAR•LASER DETECTORS



INTRODUCTION

1

Dear Whistler Owner,
Congratulations on your purchase of a Whistler radar•laser detector.

Reflecting our continued commitment of providing innovative detection products, your Whistler detector integrates radar and laser detection in a high quality design. In addition to providing complete coverage of all radar and laser speed monitoring guns, your Whistler includes many preferred features. It also detects the new Safety Warning System™. This provides advanced warning of various highway hazards, enabling you to respond more appropriately to potentially dangerous conditions. The Whistler 1630 also offers the benefit of nondetectability by alerting you to the presence of the VG-2 (a "radar detector detector").

To fully acquaint yourself with the operation of your unit and to better understand the differences between detecting radar and laser signals, we recommend reading this entire manual.

Enjoy your Whistler detector and please drive safely.

Sincerely,

WHISTLER CORPORATION

MODEL FEATURES

2

Whistler's ergonomic and user-friendly design provides a new level of operating convenience. Special features include:

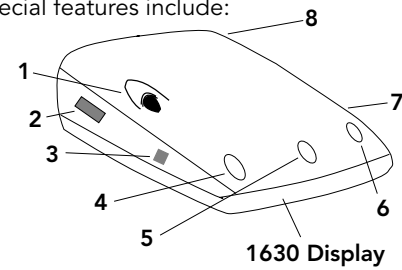

- 1. Rear Laser Antenna (1630)** - An integrated optical waveguide provides superior detection of laser signals transmitted from behind.
- 2. Bracket Release Button** - Provides quick and easy release of the mounting bracket.
- 3. Power/Volume Control (PWR/VOL)** - A single control turns the unit on/off and adjusts audio level.
- 4. QUIET Button** - Pressing QUIET before a signal is detected replaces the continuous audio alert with an auto-mute audio pattern (1630 only). Pressing QUIET during a radar/laser encounter silences audio alerts, while allowing visual alerts to keep you informed.
- 5. VG-2 Button (1630 only)** - Engages (one beep) or disengages (2 beeps) VG-2 Cloaking Technology™ for nondetectability.

MODEL FEATURES

3

- 6. CITY Button** - Reduces the annoyance of false alerts typically encountered in urban driving areas.
- 7. Speaker** - Provides distinct audio warnings for X, K, Ka band, instant-on (pulse) radar, safety radar and laser.
- 8. Power Jack** - Provides connection for the power cord.
- 9. Radar Antenna** - Compact, high-efficiency antenna receives radar signals.
- 10. Laser Antenna** - Provides long range laser detection. Both antennas must have an unobstructed view of the road.
- 11. Mounting Bracket Location** - Slot holds mounting bracket firmly.

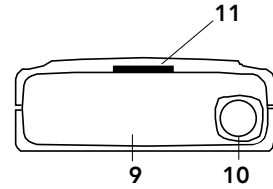

Accessories included are highly functional and easy to use.

- Power Cord** - Connects to the unit's power jack and your vehicle's lighter socket.
- Windshield Bracket** - For installing the unit on your vehicle's windshield.
- Hook & Loop Fasteners** - Designed to secure the unit on a level dashboard.

LED DISPLAYS

4

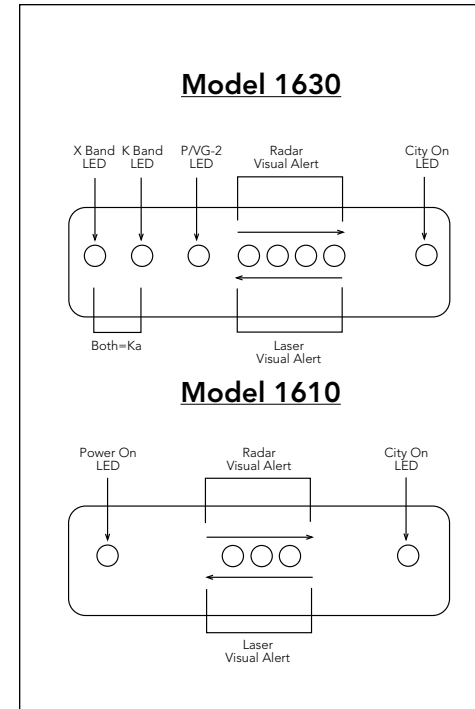

OPERATION

5

Power On And Self-Test - Each time your Whistler detector is turned on, an automatic self-test sequence confirms that the speaker and visual displays are functional. During Power Up, all the LEDs illuminate, while the X, K, and Ka alerts are sounded in sequence. Immediately after the radar alerts, the red LEDs are momentarily cancelled, then illuminate from right to left while the laser alert is sounded. After the laser alert the 1st and 4th (3rd on 1610) alert LEDs flash and the Safety Radar alert is sounded. At the end of the self-test sequence the unit is in highway mode.

Feature Engaged Confirmation
Your Whistler detector provides audible confirmation each time a feature is engaged or canceled. When a button is pressed, one beep confirms feature "on", two beeps confirm feature "off". With Feature Engaged Confirmation, you receive immediate feedback concerning the status of your unit.

Quiet Mode The QUIET Button accesses one of two muting options.

1. Manual Quiet When an audio alert is sounded, you can silence the alarm by pressing QUIET. The only time you can engage Manual Quiet is during an audio alert.

OPERATION

6

2. Pre-set Audio Quiet (1630 only) Pressing QUIET before a radar signal is detected provides an alternate alert pattern, consisting of four beeps (indicating X, K, Ka or Safety radar) followed by clicking. The clicking will continue for as long as the detected signal is present or any new signal is detected within 20 seconds, becoming more rapid as the strength of the signal increases. If Pre-set Audio Quiet is engaged, pressing QUIET while the unit is alarming will cancel the beeps or clicking. Pressing QUIET a second time when the unit is not alarming will cancel Pre-set Audio Quiet mode and restore the continuous audio alert pattern.

City Mode Automatic door openers, intrusion alarms, and other devices which share frequencies with police radar can be the source of misleading alerts, especially in urban and suburban areas. Driving in City mode will reduce these unwanted audio alerts while keeping you quietly informed of signal activity with visual alerts. Pressing the CITY Button engages City mode. Pressing the CITY Button a second time cancels City mode.

In City mode, the unit responds to X, K, Ka, or Safety radar signals by alerting you with an initial alarm (2 beeps), and then remains quiet unless the strength of the detected signal becomes very strong. Two additional beeps are provided when a weak signal becomes strong.

RADAR ALERTS

7

Highway Mode Highway mode provides full audio warnings any time radar (X, K, Ka, Safety) or laser signals are detected, and is recommended for open road driving. Highway mode is automatically engaged after the unit is turned on and completes the self-test.

Radar Audio And Visual Alerts When your Whistler detector encounters traffic radar, it provides a distinctive audio tone for the specific radar band detected: X, K, or Ka. At the same time, LEDs illuminate sequentially from left to right (see page 4). The green and amber LEDs are cancelled during an alert. The audio alerts are continuous, but have a Geiger counter-like pattern to help you determine your distance from the radar source; the faster the beeping, the closer you are to the transmitting source.

At the same time, illumination of multiple LEDs indicates relative signal strength.

Pulse Protection® Pulse (or instant-on) radar is more difficult to detect than conventional radar because it remains "off" until activated to measure the speed of a targeted vehicle.

When a pulse type transmission is detected, your Whistler detector sounds an urgent 3-second audio warning and flashes the red LEDs at their fastest rate. After the 3-second pulse alert, the standard alert pattern continues for as long

RADAR ALERTS

8

as the signal is present. It is important to respond promptly to a pulse alert, since warning time may be minimal.

Safety Radar Audio/Visual Alerts
Your Whistler detector detects the new Safety Warning System™. This provides advanced warning of various road hazards including accident sites, highway construction, emergency vehicles, etc. and enables you to respond more appropriately to potentially dangerous conditions. When your Whistler detector detects a safety radar signal, it provides a distinctive audio tone and illuminates the first LED and the last LED in the signal strength display.

Model 1630

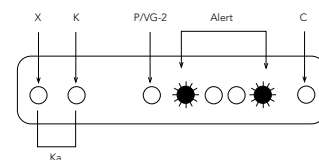

The first and last LED in the Signal Strength display flash to indicate detection of a Safety radar signal.

Model 1610

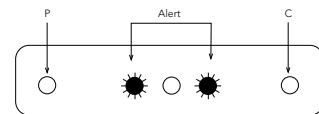

The first and last LED in the Signal Strength display flash to indicate detection of a Safety radar signal.

RADAR • LASER ALERTS

9

The Safety radar alert is displayed for as long as the signal is present and the audio alert is continuous, but has a Geiger counter like pattern to help you determine your distance from the Safety radar source; the faster the beeping, the closer you are to the source.

Radar Band Identification (1630)
When the Whistler 1630 encounters traffic radar, the Radar Band Indicators confirm the band detected by illuminating one or both of the LEDs as follows:

- X Band — Amber LED Only
- K Band — Red LED Only
- Ka Band — Amber And Red LEDs Illuminate

Laser Audio And Visual Alerts
If you are the targeted vehicle, a laser gun can often determine your speed within a few seconds after you receive an alert. In this situation there is generally no time to safely adjust your speed. However, if you are traveling near or behind the targeted vehicle and receive an alert, response time should be sufficient. Any laser alert, regardless of duration, requires immediate action! When your Whistler detects a laser signal, the laser audio alert is sounded and the four red LEDs (three red LEDs on 1610) illuminate from right to left for as long as the signal is present, or for a minimum of three seconds.

LASER • VG-2 ALERTS

10

When the laser signal is no longer detected, the audio warning ends, but the LEDs continue to flash slowly for three seconds, indicating a laser encounter has just occurred.

VG-2 Detection Mode (1630 only) The VG-2, also known as a "radar detector detector," is a special receiver used by police to detect signals radiated by a radar detector. Because of your Whistler detector's superior sensitivity and low radiated signal level, you will be able to detect the VG-2 before the VG-2 is able to detect you.

Press the VG-2 button once to engage, unit beeps once. Pressing a second time cancels VG-2 detection mode, unit beeps twice and the VG-2 LED is disengaged.

When a VG-2 signal is detected the P/VG-2 LED flashes rapidly for 3 seconds and the VG-2 alert is sounded. After the 3 seconds the audio is canceled and the P/VG-2 alert LED flashes at a slower rate. This cycle is repeated if the VG-2 signal is again detected.

During the period a VG-2 signal is detected, a radar signal cannot be detected. However, because the VG-2 alert has confirmed that a patrol car is nearby, you are already aware of the potential for speed monitoring and can adjust your speed accordingly. Laser detection is not affected while a VG-2 signal is detected.

VEHICLE BATTERY SAVER

11

Vehicle Battery Saver Mode (1630 only)
The Vehicle Battery Saver mode automatically shuts off your detector within 3 hours if you forget to turn it off. The timer is reset if the detector is turned off, unplugged or any button is pressed before the 3 hours has expired. The detector will alert you with an audible and visual warning before it shuts off. Display shows:

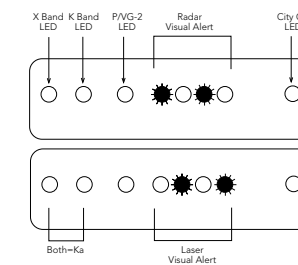

The Red LED's flash in an alternating pattern

During this warning you can momentarily reset the unit by pressing any button. This will reset the timer.

If the unit has automatically turned itself off, press any button to turn the unit back on. You can manually engage the Vehicle Battery Saver mode by pressing and holding the City button until one beep is heard.

INSTALLATION

12

Mounting Guidelines
For effective detection of radar and laser signals, it is important to mount your unit properly. Performance will be best if you position the detector with a level, through-the-windshield view of the road ahead. (Remember, your unit's "eyes" are at the end opposite from the LED's and controls.)

- Here are some additional points to keep in mind.
- Do not mount your detector behind wipers, ornaments, mirrored sunscreens, etc. These obstructions have metal surfaces which can block radar and laser signals and reduce critical warning time. (Regular tinted glass does not affect reception.)
- Some newer windshields have an Instaclear™ or Electriclear™ type coating, which block radar and laser signals. Consult your dealer or the owner's manual supplied with your vehicle to determine if your windshield has this coating.
- To reduce the possibility of theft, conceal your unit when not in use.
- Do not use windshield mount on vehicles with a plastic safety coating on the inside of the windshield. Bracket may leave permanent marks on this type of windshield. See vehicle's owner's manual.

Model Specifications

- Dimensions:** 1.25"H x 2.7" W x 3.9" L
- Weight:** 5.5 ozs.
- Laser Frequencies:** 905±50 nanometers (nm)
- Radar Frequencies:** 10.500 - 10.550 GHz (X band)
24.050 - 24.250 GHz (K band)
33.400 - 36.000 GHz (Superwideband Ka)
- Operating Temperature Range:** -20°C to +80°C (-4°F to +176°F)
- Power Requirements:** Operational 12 to 15 volts DC, 200 mA nominal

Specifications are subject to change without notice.

Whistler P/N 203139
16 Elizabeth Drive Whistler 1999
Chelmsford, MA 01824 Patents Pending

Consumer Relations: (800) 531-0004

INSTALLATION

13

Dash Mounting

Make sure the mounting location you have chosen is clean and dry. Clean with isopropyl alcohol if necessary to remove any waxes or polishes.

Separate the hook & loop fastener strips. Peel the backing off each strip, adhere one piece to the dash and the other piece to the bottom of the unit, taking care not to cover the serial number.

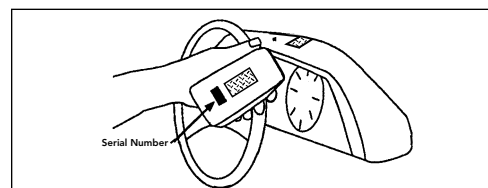

Be careful not to place the strip over the unit's serial number. If the strip is removed, the serial number may be pulled off the unit. Units without serial numbers are not covered under warranty.

When joined, the two strips provide a secure mount, yet the unit can be easily removed for safekeeping when not in use. Once mounted, your unit is ready to be connected to the power cord.

Visor Mounting (optional accessory)

Place the bracket into the bracket mounting slot of the detector. To install your detector on the visor, slide bracket clip over the rear edge of the visor as shown in the illustration.

INSTALLATION

14

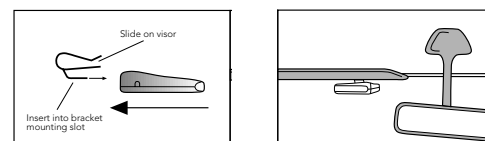

When visor mounting, make sure your unit is relatively level and has a clear view of the road ahead.

Power Connection

Plug the small end of the power cord into the unit's power jack, then plug the large end of the cord into your vehicle's lighter socket. Make sure the plug fits snugly, and be sure to keep the socket and contacts free of ashes and dirt.

Windshield Mounting

With the windshield mounting kit your Whistler detector can be mounted to your vehicle's windshield. First, install the two suction cups and rubber bumper onto the bracket by fitting them into their holes. Now, press the suction cups onto the windshield glass at the location you have chosen. Slide the detector onto the bracket until it locks into place. If necessary, you may adjust the bracket to the proper angle by bending it. Remove detector before bending bracket. To remove the bracket, pull the tab on each suction cup.

INSTALLATION

15

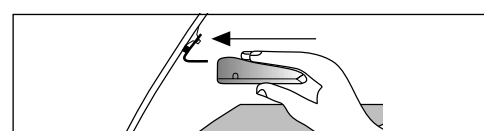

To make the unit level, you can easily adjust the angle of the windshield bracket by bending it.

Fuse Replacement

The lighter socket plug is equipped with a replaceable 2 amp 3AG fuse located behind the silver tip. To replace the fuse, carefully unscrew the tip of the plug. (**Important note:** Unscrew slowly. The tip contains a spring which may fly out when disassembling.) Insert the new fuse with spring and screw the tip on. With use, screwcap on plug may loosen. **Retighten occasionally.**

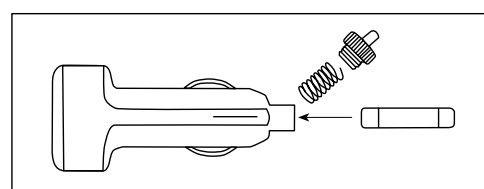

Unscrew the tip of the lighter socket plug carefully when replacing the 2 amp fuse.

TROUBLESHOOTING GUIDE

16

If your unit has been correctly installed following the guidelines in this manual, but is not operating optimally, please refer to this chart:

Problem	Action
No display or audio.	<ul style="list-style-type: none"> • Check fuse in Whistler plug; replace if necessary. • Check fuse for lighter socket; replace if necessary. • Make sure lighter socket is clean and fully operational.
Unit alarms when vehicle hits bumps.	<ul style="list-style-type: none"> • Check for loose lighter socket; tighten and clean socket. • Check connections at both ends of power cord. Substitute another cord to determine if cord is defective. Return defective cord to factory.

TROUBLESHOOTING GUIDE

17

Problem	Action
Unit alarms when using vehicle equipment or electrical accessories (brakes, power mirrors/windows, directionals, horn, etc.).	<ul style="list-style-type: none"> • Check vehicle's electrical system, including battery and alternator. • Install a filter capacitor (470µfd. 25 volt or larger capacitance value) on the back of the lighter socket.
Audio alerts are not loud enough.	<ul style="list-style-type: none"> • Cancel Pre-set Audio-Quiet. (see pg. 6). • Check PWR/VOL control setting.

Your Whistler detector is expertly engineered and designed to exacting quality standards to provide you with reliable, trouble-free operation. If difficulties occur which cannot be solved by information provided in this Troubleshooting Guide, please call Whistler Consumer Relations at 1-800-531-0004 before returning your unit for service or contact us via e-mail: info@whistlercorp.com.

SPEED MONITORING TECHNOLOGIES

18

Radar Facts

Very simply, a radar gun operates by transmitting radio waves at certain frequencies which reflect off objects and are then picked up by the radar gun's receiving section.

When a radar beam reflects off a moving target, such as your vehicle, a measurable frequency shift occurs. The radar unit converts this shift into miles per hour to determine your vehicle's speed. Currently, the FCC (Federal Communications Commission) permits operation of traffic radar guns at these frequencies:

- X band (10.500 GHz - 10.550 GHz)
- K band (24.050 GHz - 24.250 GHz)
- Ka band (33.400 GHz - 36.000 GHz)

Laser Facts

It's well documented that many radar guns cannot reliably provide the speed of a targeted vehicle that is traveling in a group of vehicles. In contrast, a laser gun can target a specific vehicle out of a line of traffic and determine its speed.

The advantage of laser over radar in terms of target identification is the result of the laser gun's narrow beam. A radar transmission can cover more than a four-lane highway at a distance of 1,000 feet, compared with a laser transmission which covers about 6 feet at the same distance. This is one reason why laser is more difficult to detect than radar.

SPEED MONITORING TECHNOLOGIES

19

For best protection keep these additional suggestions in mind:

- Because your vehicle's license plate or headlights are the laser gun's primary targets, mounting your Whistler detector on the dash can improve laser detection at short range.
- Do not follow closely behind any vehicle you cannot see through. If you can't see past a vehicle ahead of you, chances are your detector won't either.
- The receiving range of your laser detector will not be the same as a radar detector. Laser guns are most often used at short range.

Other Speed Detection Systems

Several techniques other than radar or laser are used to measure vehicle speeds. When these methods are being used, no detector can provide a warning. These techniques include:

- Pacing - A patrol car drives behind you and matches your driving speed.
- Vascar/Aircraft - The time it takes a vehicle to travel a known distance is measured.

SPEED MONITORING TECHNOLOGIES

20

Radar Detector Detectors

The Interceptor VG-2, or simply VG-2, is a microwave receiver used by police to detect signals radiated by the local oscillator of a radar detector. Because its purpose is to identify persons driving with radar detectors, the VG-2 is known as a "radar detector detector". The VG-2 is the primary tool used by the police to identify radar detector equipped vehicles. If caught, drivers in Virginia, Washington D.C. and Western Canada and all truck drivers risk losing their radar detector and receiving a fine. In addition, instant-on radar is almost always used in combination with the VG-2, leaving unsuspecting motorists vulnerable to receiving two tickets—one potentially for speeding, the other for possession of a detector.

Having a radar detector capable of detecting the VG-2 alerts you to the presence of a speed trap and preserves your radar detector investment.

ARE DETECTORS LEGAL?

21

Are Detectors Legal?

Laser detectors are completely legal in every state when used in automobiles or light trucks (under 10,000 lbs.). Similarly, when used in automobiles or light trucks, radar detectors are legal in almost every state. Exceptions are Virginia and Washington D.C., which have local regulations restricting the use of radar receivers in any vehicle.

Concerning trucks over 10,000 lbs., the Federal Highway Administration (FHWA) issued a regulation, effective January, 1994 which prohibits radar and laser detector use in these types of vehicles nationally.

Prior to the FHWA regulation, laws existed in the state of New York restricting the use of radar detectors in trucks over 18,000 lbs. and in Illinois in trucks over 26,000 lbs.

WARRANTY INFORMATION

22

Consumer Warranty

Your Whistler detector is warranted to the original purchaser for a period of one year from the date of original purchase against all defects in materials and workmanship. This limited warranty is void if the unit is abused, modified, installed improperly, if the housing has been removed, or if the serial number is missing. There are no express warranties covering this product other than those set forth in this warranty. All express or implied warranties for this product are limited to one year. Whistler is not liable for damages of any type arising from the use, misuse, or operation of this product.

Service Under Warranty

During the warranty period, defective units will be repaired or replaced (with the same or a comparable model), at Whistler's option, without charge to the purchaser when returned prepaid, with dated proof of purchase to the address on pg. 23. Units returned without dated proof of purchase will be handled as described in the section "Service Out Of Warranty." Due to the specialized equipment necessary for testing a radar/laser receiver, there are no authorized service stations for Whistler brand detectors other than the factory.

WARRANTY INFORMATION

23

When returning a unit for service under warranty, please follow these instructions:

1. Ship the unit in original carton or in a suitable sturdy equivalent, fully insured, with return receipt requested, and shipping charges prepaid to:

Whistler Repair Dept.
16 Elizabeth Drive
Chelmsford, MA 01824

IMPORTANT: Whistler will not assume responsibility for loss or damage incurred in shipping. Therefore, please ship your unit insured with return receipt requested.

2. Include with your unit the following information, clearly printed:

Your name and street address (for shipping via UPS), and a daytime telephone number. (No P.O. Box please.)

A detailed description of the problem (e.g., "Unit performs self-test but does not respond to radar").

A copy of your dated proof of purchase or bill of sale.

3. Be certain your unit is returned with its serial number. For reference, we recommend keeping a record of your unit's serial number. Units without serial numbers are not covered under warranty.

WARRANTY INFORMATION

24

IMPORTANT: To validate that your unit is within the warranty period, make sure you keep a copy of your dated proof of purchase.

Service Out Of Warranty

Units will be repaired at "out of warranty" service rates when:

- The unit's original warranty has expired.
- Dated proof of purchase is not supplied.
- The unit has been returned without its serial number.
- The unit has been abused, modified, installed improperly, or had its housing removed.

The minimum out of warranty service fee for your Whistler detector is \$45.00 (U.S.). If you require out of warranty service, please return your unit as outlined in the section "Service Under Warranty" along with a certified check or money order for \$45.00. (Payment may also be made by MasterCard or Visa; personal checks are not accepted.) In the event repairs cannot be covered by the minimum \$45.00 service fee, you will be contacted by a Whistler technical service specialist who will outline options available to you. If you elect not to have your unit repaired/replaced, it will be returned to you and your money refunded.

IMPORTANT: When returning your unit for service, be certain to include a daytime telephone number.

WARRANTY INFORMATION

25

Consumer Relations

If you have questions concerning the operation of your Whistler detector, or service during or after the warranty period, please call Consumer Relations at 1-800-531-0004. Representatives are available to answer your questions Monday- Friday from 9:00 a.m. to 5:00 p.m. (EST), or you may e-mail questions to us at info@whistlercorp.com. Please allow 3-5 days for e-mail response.

ACCESSORIES

26

The following accessories are available through Whistler retailers or can be ordered directly from Whistler by calling 1-800-531-0004.

Order Code	Description	Price
202138	Visor Bracket	\$6.95
202139	Windshield Bracket	\$9.95
206552	Straight Power Cord (5')	\$14.95
206553	Coiled Power Cord (7')	\$15.95
206879	Hook & Loop	\$ 1.95
206880	Hardwire Kit (10')	\$ 9.95

Shipping and Handling (Per Order) \$ 3.00

Massachusetts residents please add applicable sales tax. Prices are subject to change without notice.

Free Manuals Download Website

<http://myh66.com>

<http://usermanuals.us>

<http://www.somanuals.com>

<http://www.4manuals.cc>

<http://www.manual-lib.com>

<http://www.404manual.com>

<http://www.luxmanual.com>

<http://aubethermostatmanual.com>

Golf course search by state

<http://golfingnear.com>

Email search by domain

<http://emailbydomain.com>

Auto manuals search

<http://auto.somanuals.com>

TV manuals search

<http://tv.somanuals.com>