



Operating Instructions and Parts Manual
16-Inch Woodworking Band Saw
Model JWBS-16B



WMH TOOL GROUP, Inc.
2420 Vantage Drive
Elgin, Illinois 60124
Ph.: 800-274-6848
www.wmhtoolgroup.com

Part No. M-708749B
Revision A 03/08
Copyright © 2008 WMH Tool Group, Inc.

Warranty and Service

WMH Tool Group, Inc., warrants every product it sells. If one of our tools needs service or repair, one of our Authorized Service Centers located throughout the United States can give you quick service. In most cases, any of these WMH Tool Group Authorized Service Centers can authorize warranty repair, assist you in obtaining parts, or perform routine maintenance and major repair on your JET® tools. For the name of an Authorized Service Center in your area call 1-800-274-6848.

MORE INFORMATION

WMH Tool Group is consistently adding new products to the line. For complete, up-to-date product information, check with your local WMH Tool Group distributor, or visit jettools.com.

WARRANTY

JET products carry a limited warranty which varies in duration based upon the product. (MW = Metalworking, WW = Woodworking)

| | | | | | | |
|---|--|--|--|---|---|--|
| 90 DAY WARRANTY | 1 YEAR WARRANTY | 2 YEAR WARRANTY | 5 YEAR WARRANTY | LIFE LIFETIME WARRANTY | | |
| Lathe Accessories Machine Accessories Mobile Bases Safety Equipment Specialty Items Vise Accessories | Air Tools- Contractor Air Tools-Industrial Air Tools-Light Industrial Lubrication | Body Repair Kits Bottle Jacks Cable Pullers Cold Saws Hoists-Air Hoists-Electric Metalforming Mill/Drills Milling Machines | MW Bandsaws MW Drill Presses MW Finishing Equipment MW Lathes MW Precision Vises Pallet Trucks | Rigging Equip. Service Jacks Stackers Surface Grinders Tapping Trolleys-Air Trolleys-Electric Web Slings Winches-Electric | <i>Warranty reverts to 1 Year Warranty if woodworking (WW) products listed below are used for commercial, industrial or educational purposes.</i> Trolleys-Geared Trolleys-Plain Winches-Manual Manual WW Air Filtration WW Bandsaws Pullers-JCH Models Scissor Lift Tables Screw Jacks WW Dust Filters WW Dust Fittings WW Joints WW Lathes WW Planers WW Sanders WW Shapers WW Tablesaws | Fastening Tools Mechanics Hand Tools Striking Tools Vises (non-precision) Clamps |

WHAT IS COVERED?

This warranty covers any defects in workmanship or materials subject to the exceptions stated below. Cutting tools, abrasives and other consumables are excluded from warranty coverage.

WHO IS COVERED?

This warranty covers only the initial purchaser of the product.

WHAT IS THE PERIOD OF COVERAGE?

The general JET warranty lasts for the time period specified in the product literature of each product.

WHAT IS NOT COVERED?

Five Year Warranties do not cover woodworking (WW) products used for commercial, industrial or educational purposes. Woodworking products with Five Year Warranties that are used for commercial, industrial or education purposes revert to a One Year Warranty. This warranty does not cover defects due directly or indirectly to misuse, abuse, negligence or accidents, normal wear-and-tear, improper repair or alterations, or lack of maintenance.

HOW TO GET SERVICE

The product or part must be returned for examination, postage prepaid, to a location designated by us. For the name of the location nearest you, please call 1-800-274-6848.

You must provide proof of initial purchase date and an explanation of the complaint must accompany the merchandise. If our inspection discloses a defect, we will repair or replace the product, or refund the purchase price, at our option.

We will return the repaired product or replacement at our expense unless it is determined by us that there is no defect, or that the defect resulted from causes not within the scope of our warranty in which case we will, at your direction, dispose of or return the product. In the event you choose to have the product returned, you will be responsible for the shipping and handling costs of the return.

HOW STATE LAW APPLIES

This warranty gives you specific legal rights; you may also have other rights which vary from state to state.

LIMITATIONS ON THIS WARRANTY

WMH TOOL GROUP LIMITS ALL IMPLIED WARRANTIES TO THE PERIOD OF THE LIMITED WARRANTY FOR EACH PRODUCT. EXCEPT AS STATED HEREIN, ANY IMPLIED WARRANTIES OR MERCHANTABILITY AND FITNESS ARE EXCLUDED. SOME STATES DO NOT ALLOW LIMITATIONS ON HOW LONG THE IMPLIED WARRANTY LASTS, SO THE ABOVE LIMITATION MAY NOT APPLY TO YOU.

WMH TOOL GROUP SHALL IN NO EVENT BE LIABLE FOR DEATH, INJURIES TO PERSONS OR PROPERTY, OR FOR INCIDENTAL, CONTINGENT, SPECIAL, OR CONSEQUENTIAL DAMAGES ARISING FROM THE USE OF OUR PRODUCTS. SOME STATES DO NOT ALLOW THE EXCLUSION OR LIMITATION OF INCIDENTAL OR CONSEQUENTIAL DAMAGES, SO THE ABOVE LIMITATION OR EXCLUSION MAY NOT APPLY TO YOU.

WMH Tool Group sells through distributors only. The specifications in WMH catalogs are given as general information and are not binding. Members of WMH Tool Group reserve the right to effect at any time, without prior notice, those alterations to parts, fittings, and accessory equipment which they may deem necessary for any reason whatsoever. JET® branded products are not sold in Canada by WMH Tool Group.

Table of Contents

| | |
|--|----|
| Warranty and Service..... | 2 |
| Table of Contents | 3 |
| Warning | 4 |
| Introduction | 6 |
| Specifications | 6 |
| Grounding Instructions..... | 7 |
| Unpacking | 8 |
| Contents of Shipping Container | 8 |
| Assembly and Setup | 9 |
| Base Support Extension..... | 9 |
| Adjusting Blade Tension..... | 10 |
| Adjusting Blade Tracking..... | 10 |
| Lower Blade Guide Adjustment..... | 11 |
| Mounting the Table..... | 12 |
| Rail Assembly (optional accessory) | 13 |
| Fence Assembly and Adjustment (optional accessory) | 13 |
| Resaw Guide (optional accessory)..... | 14 |
| Miter Gauge (optional accessory) | 14 |
| Tilting the Table | 15 |
| Height Scale Adjustment | 15 |
| Changing Blades | 16 |
| Replacing V-Belt..... | 17 |
| Adjusting Belt Tension..... | 17 |
| Electrical Connections | 18 |
| Maintenance | 18 |
| Upper Blade Guide Adjustment..... | 10 |
| Troubleshooting | 19 |
| Parts | 19 |
| Replacement Parts..... | 19 |
| Upper Wheel Assembly | 20 |
| Lower Wheel and Motor Assembly..... | 22 |
| Blade Guides Assembly | 24 |
| Table Assembly | 26 |
| Fence & Miter Assembly (optional accessory) | 28 |
| Wiring Diagram | 30 |

Warnings

1. Read and understand the entire owner's manual before attempting assembly or operation.
2. Read and understand the warnings posted on the machine and in this manual. Failure to comply with all of these warnings may cause serious injury.
3. Replace the warning labels if they become obscured or removed.
4. This band saw is designed and intended for use by properly trained and experienced personnel only. If you are not familiar with the proper and safe operation of a band saw, do not use until proper training and knowledge have been obtained.
5. Do not use this band saw for other than its intended use. If used for other purposes, WMH Tool Group disclaims any real or implied warranty and holds itself harmless from any injury that may result from that use.
6. Always wear approved safety glasses/face shields while using this band saw. Everyday eyeglasses only have impact resistant lenses; they are not safety glasses.
7. Before operating this band saw, remove tie, rings, watches and other jewelry, and roll sleeves up past the elbows. Remove all loose clothing and confine long hair. Non-slip footwear or anti-skid floor strips are recommended. Do not wear gloves.
8. Wear ear protectors (plugs or muffs) during extended periods of operation.
9. Some dust created by power sanding, sawing, grinding, drilling and other construction activities contain chemicals known to cause cancer, birth defects or other reproductive harm. Some examples of these chemicals are:
 - Lead from lead based paint.
 - Crystalline silica from bricks, cement and other masonry products.
 - Arsenic and chromium from chemically treated lumber.Your risk of exposure varies, depending on how often you do this type of work. To reduce your exposure to these chemicals, work in a well-ventilated area and work with approved safety equipment, such as face or dust masks that are specifically designed to filter out microscopic particles.
10. Do not operate this machine while tired or under the influence of drugs, alcohol or any medication.
11. Make certain the switch is in the OFF position before connecting the machine to the power supply.
12. Make certain the machine is properly grounded.
13. Make all machine adjustments or maintenance with the machine unplugged from the power source.
14. Remove adjusting keys and wrenches. Form a habit of checking to see that keys and adjusting wrenches are removed from the machine before turning it on.
15. Keep safety guards in place at all times when the machine is in use. If removed for maintenance purposes, use extreme caution and replace the guards immediately.
16. Check damaged parts. Before further use of the machine, a guard or other part that is damaged should be carefully checked to determine that it will operate properly and perform its intended function. Check for alignment of moving parts, binding of moving parts, breakage of parts, mounting and any other conditions that may affect its operation. A guard or other part that is damaged should be properly repaired or replaced.
17. Provide for adequate space surrounding work area and non-glare, overhead lighting.
18. Keep the floor around the machine clean and free of scrap material, oil and grease.
19. Keep visitors a safe distance from the work area. **Keep children away.**



Warnings

20. Make your workshop child proof with padlocks, master switches or by removing starter keys.
21. Give your work undivided attention. Looking around, carrying on a conversation and “horse-play” are careless acts that can result in serious injury.
22. Maintain a balanced stance at all times so that you do not fall or lean against the blade or other moving parts. Do not overreach or use excessive force to perform any machine operation.
23. Use the right tool at the correct speed and feed rate. Do not force a tool or attachment to do a job for which it was not designed. The right tool will do the job better and safer.
24. Use recommended accessories; improper accessories may be hazardous.
25. Maintain tools with care. Keep blades sharp and clean for the best and safest performance. Follow instructions for lubricating and changing accessories.
26. Turn off the machine before cleaning. Use a brush or compressed air to remove chips or debris — do not use your hands.
27. Do not stand on the machine. Serious injury could occur if the machine tips over.
28. Never leave the machine running unattended. Turn the power off and do not leave the machine until it comes to a complete stop.
29. Remove loose items and unnecessary work pieces from the area before starting the machine.

Familiarize yourself with the following safety notices used in this manual:

CAUTION This means that if precautions are not heeded, it may result in minor injury and/or possible machine damage.

WARNING This means that if precautions are not heeded, it may result in serious injury or possibly even death.

- - SAVE THESE INSTRUCTIONS - -

Introduction

This manual is provided by Jet covering the safe operation and maintenance procedures for model JWBS-16B Band Saw. This manual contains instructions on installation, safety precautions, general operating procedures, maintenance instructions and parts breakdown. This machine has been designed and constructed to provide years of trouble free operation if used in accordance with instructions set forth in this manual. If there are any questions or comments, please contact either your local supplier or WMH Tool Group. WMH Tool Group can also be reached at our web site: www.wmhtoolgroup.com.

Specifications

| | |
|---|--------------------------------|
| Stock Number | 708749B |
| Cutting Capacity (height)..... | 10" |
| Cutting Capacity (width)..... | 16" |
| Maximum Rip Left of Blade w/Fence | 14-1/4" |
| Blade Length | 123" |
| Blade Speed..... | 3000 SFPM |
| Minimum Blade Width | 1/8" |
| Maximum Blade Width | 1-1/2" |
| Table Size | 17" x 17" |
| Table Tilt..... | 45°R to 10°L |
| Table Height from Floor | 35" |
| Wheel Diameter | 16-5/8" |
| Dust Chute Diameter..... | 4" |
| Overall Dimensions | 68" H x 31-1/2" W x 26-3/8" D |
| Motor | 1-1/2 HP, 1Ph |
| | 115/230V, prewired 115V |
| Net Weight (approx.)..... | 317 lbs. |
| Shipping Weight (approx.)..... | 340 lbs. |

The specifications in this manual are given as general information and are not binding. The WMH Tool Group reserves the right to effect, at any time and without prior notice, changes or alterations to parts, fittings, and accessory equipment deemed necessary for any reason whatsoever.

Grounding Instructions

⚠ WARNING This machine must be grounded while in use to protect the operator from electric shock.

In the event of a malfunction or breakdown, grounding provides a path of least resistance for electric current to reduce the risk of electric shock. This machine is equipped with an electric cord having an equipment-grounding conductor and a grounding plug. The plug must be plugged into a matching outlet that is properly installed and grounded in accordance with all local codes and ordinances.

Do not modify the plug provided. If it will not fit the outlet, have the proper outlet installed by a qualified electrician.

Improper connection of the equipment-grounding conductor can result in a risk of electric shock. The conductor, with insulation having an outer surface that is green with or without yellow stripes, is the equipment-grounding conductor. If repair or replacement of the electric cord or plug is necessary, do not connect the equipment-grounding conductor to a live terminal.

Check with a qualified electrician or service personnel if the grounding instructions are not completely understood, or if in doubt as to whether the tool is properly grounded. Use only three wire extension cords that have three-prong grounding plugs and three-pole receptacles that accept the tool's plug.

Repair or replace a damaged or worn cord immediately.

Model JWBS-16B

Model JWBS-16B Band Saw has a 1-3/4 HP 1 phase motor and is wired from the factory for 115 volt operation, but can be rewired for 220 volts.

115 Volt Operation

The JWBS-16B Band Saw comes equipped with a *plug* that looks like A, Fig. 1. and is used in an *outlet* that looks like B, Fig. 1. A *temporary adapter* with a *grounding ear* secured with a *screw* (C, Fig. 1) may be used to connect this plug to a two-pole receptacle if a properly grounded outlet is not available. The temporary adapter should only be used until a properly grounded outlet can be installed by a qualified electrician. **This adapter is not applicable in**

Canada. The green colored *grounding ear*, lug, or tab, extending from the adapter, must be connected to a permanent ground such as a properly grounded outlet box, as shown in C, Fig. 1.

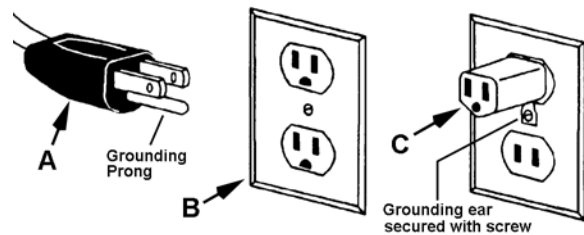

Figure 1

230 Volt Operation

To convert the JWBS-16B from 120V to 230V, single phase operation, the following is strongly recommended:

Contact your local Authorized JET Service Center or qualified electrician for proper procedures to install the plug. The band saw must comply with all local and national codes after the 230V plug is installed.

The 115V attachment plug supplied with the band saw (C, Fig. 2) must be replaced with a UL/CSA listed plug suitable for 230V operation (D, Fig. 2).

The band saw with a 230V plug should only be connected to an outlet having the same configuration (D, Fig. 2). No adapter is available or should be used with the 230V plug.

Important: In all cases (115 or 230 volts), make certain the receptacle in question is properly grounded. If you are not sure, have a registered electrician check the receptacle.

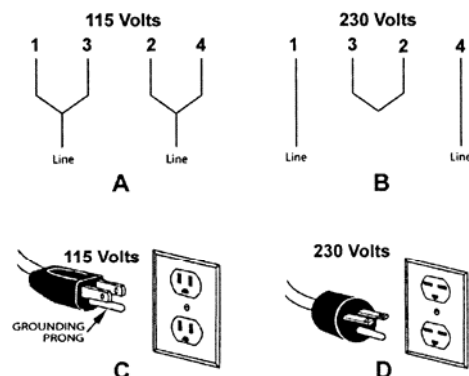

Figure 2

Unpacking

Remove the packing material from the band saw.

Note: Remove the plywood and bolts from the base. Inspect the machine for damage. Report any damage to your distributor and shipping agent.

Move the saw to its permanent working location. The site should be dry, well lit, and have enough room to handle long stock and the service and/or adjustment of the machine from any side.

Move the band saw off the skid. Clean all rust protected surfaces with a mild solvent or diesel fuel and a soft cloth. Do not use lacquer thinner, paint thinner, or gasoline. These will damage painted surfaces.

Contents of Shipping Container

- 1 - Band Saw
- 1 - Table
- 1 - Owner's Manual
- 1 - Warranty Card
- 1 - Accessory Package Contains:
 - 2 - Extension Straps
 - 1 - Extension Base
 - Accessory Packeg Include
 - 2 - Knobs
 - 1 - 5mm Hex Wrench
 - 1 - 4mm Hex Wrench
 - 1 - Handle
 - 1 - 10/12mm Wrench
 - 1 - 12/14mm Wrench
 - 1 - Trunnion Support Bracket
 - 4 - Hex Cap Bolts 5/16"-18x1-1/2"
 - 4 - Lock Washers 5/16"
 - 8 - 5/16-18 x 3/8 Button Hd. Cap Screws
 - 8 - 5/16 Flat Washers

Tools Included for Assembly

- 1 - 10/12mm Open End Wrench
- 1 - 12/14mm Open End Wrench
- 1 - 5mm Hex Wrench

Tools Required for Assembly & Adjustments

- 1 - Combination Square
- 1 - Cross Point Screw Driver



Assembly and Setup

Base Support Extension

1. Attach straps (A, Fig. 1A) to extension base (B, Fig. 1A) with (2) 5/16-18 button head cap screws (C, Fig. 1A) and with (2) 5/16 flat washers (D, Fig. 1A). If needed punch holes through striping decal. NOTE: Leave screws slightly loose.
2. Repeat for opposite end of extension base.
3. Insert straps through slits in base of machine lining up holes in machine base with tapped holes in strap (Fig 1B)
4. Attach straps to machine base using (2) 5/16-18 button head Cap screw (E, Fig. 1C) and (2) 5/16 flat washers (F, Fig. 1C).
5. Repeat for opposite end of extension base.
6. Tighten all (8) button head cap screws with the 5 MM hex wrench provided.
7. Attach the handle (C, Fig. 2) to the hand wheel (D, Fig. 2).

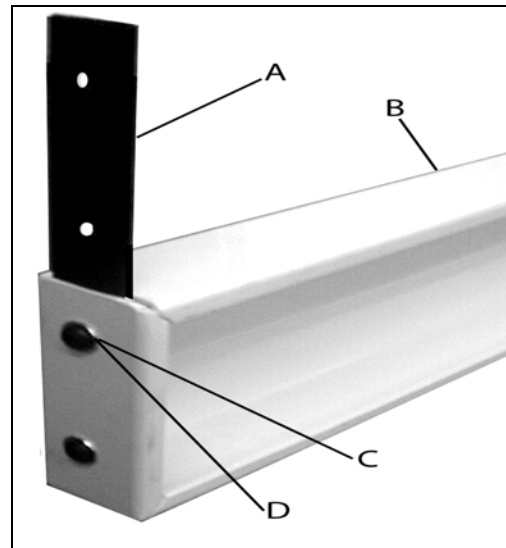

Figure 1A



Figure 1B

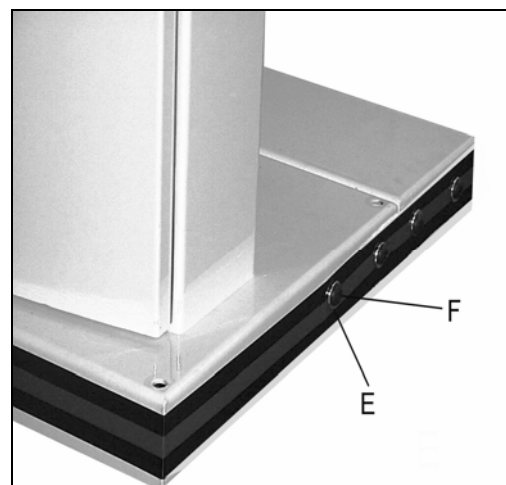

Figure 1C

Adjusting Blade Tension

1. Disconnect machine from the power source, unplug.
2. Turn blade tension hand wheel (E, Fig. 2) counter-clockwise to tension blade, and clockwise to loosen the tension. A gauge on the upper wheel slide bracket (F, Fig. 2) indicates the approximate tension according to the width of the blade. The JWBS-16B comes with a 3/4" blade so the tension should be set at 3/4" when using this blade.

As you become familiar with the saw, you may find it necessary to change the blade tension from the initial setting. Changes in blade width, and the type of material being cut will have an effect on blade tension.

Keep in mind that too little, or too much blade tension can cause blade breakage and/or poor cutting performance.

Adjusting Blade Tracking

WARNING Disconnect machine from the power source! Never adjust blade tracking with the machine running! Failure to comply may cause serious injury!

Note: Blade tracking has been adjusted at the factory. If, however, it is determined that blade tracking needs adjustment:

1. Blade must be properly tensioned before adjusting blade tracking. Make sure upper and, lower blade guides do not interfere with the blade while adjusting the tracking.
2. Open the upper wheel door. Rotate the wheel forward, and observe the position of the blade on the wheel. The blade should rest in approximately the center of the wheel.
3. If adjustment is necessary, loosen the wing nut (G, Fig. 2) at the top rear of the saw.
4. Adjust tracking by turning the knob (H, Fig. 2) in 1/4 turn increments. Rotate the wheel forward, and observe the position of the blade on the wheel. Rotating knob (H, Fig. 2) counter-clockwise should move the blade towards the front of the wheel. Rotating the knob clockwise should move the blade towards the back of the wheel.
5. Continue with adjustments until the blade is tracking properly.
6. Tighten the wing nut (G, Fig. 2).

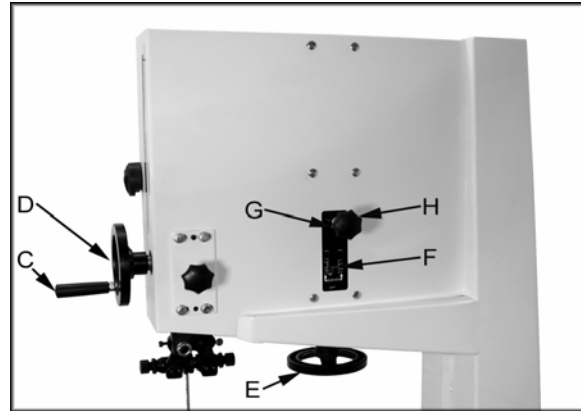

Figure 2

Upper Blade Guide Adjustment

WARNING Disconnect machine from the power source, unplug before making any adjustments! Blade teeth are sharp! Use care when working near the saw blade. Failure to comply may cause serious injury!

1. Blade tension and tracking must be properly adjusted prior to blade guide setup.
2. The blade guard has been removed in Figure 3 for photo purposes only.
3. Loosen the socket head cap screw (A, Fig. 3) and position the blade guide assembly (B, Fig. 3) so that the guides rest just behind the gullet of the blade teeth. Tighten the socket head cap screw.
4. Loosen lock nuts (D, Fig. 3).
5. Adjust guide knobs (E, Fig. 3) so guides (C, Fig. 3) rest lightly against the blade. Do not force the guides against the side of the blade. Tighten both lock nuts.
6. Adjust the blade support bearing so that it is 0.003" away from the back of the blade, about the thickness of a piece of paper. To make this adjustment loosen wing nut (F, Fig. 3) and slide the bearing and bearing post into position. Tighten wing nut.

Note: Blade support bearing should be adjusted so that the back edge of the blade overlaps the front face of the ball bearing by approximately 1/8". If adjustment is needed loosen wing nut (F, Fig. 3) and turn the bearing shaft. Tighten wing nut.

Lower Blade Guide Adjustment

⚠WARNING Disconnect machine from the power source, unplug before making any adjustments! Blade teeth are sharp! Use care when working near the saw blade. Failure to comply may cause serious injury!

1. Blade tension and tracking must be properly adjusted prior to blade guide setup.
2. The blade guard has been removed in Figure 4 for photo purposes only.
3. Loosen the socket head cap screws (G, Fig. 4) and position the blade guide assembly (H, Fig. 4) so that the guides rest just behind the gullet of the blade teeth. Tighten the socket head cap screws.
4. Loosen thumb screw (I, Fig. 4). Adjust guides (J, Fig. 4) so they rest lightly against the blade. Do not force the guide against the side of the blade. Tighten thumb screw.
5. Adjust the blade support bearing so that it is 0.003" away from the back of the blade, about the thickness of a piece of paper. To make this adjustment loosen wing nut (K, Fig. 4) and slide the bearing and bearing post into position. Tighten wing nut.

Note: Blade support bearing should be adjusted so that the back edge of the blade overlaps the front face of the ball bearing by approximately 1/8". If adjustment is needed loosen wing nut (K, Fig. 4) and turn the bearing shaft. Tighten wing nut.

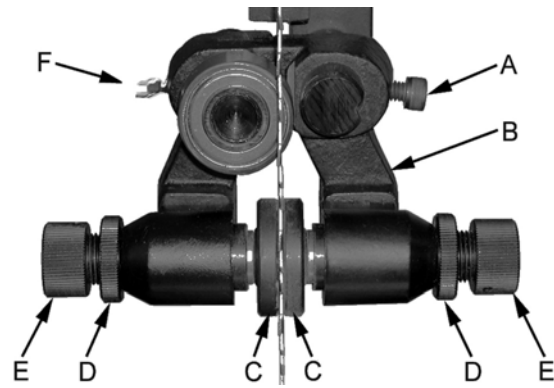

Figure 3

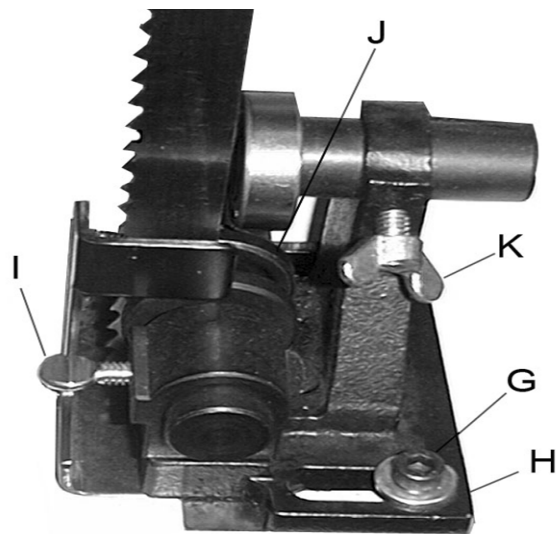

Figure 4

Mounting the Table

1. Mount the trunnion support bracket (A, Fig. 5) to the bandsaw with four 5/16" x 1-1/2" hex cap bolts, and four 5/16" lock washers (B, Fig. 5).
2. Remove the round table insert (C, Fig. 5) found where the blade goes through the table. Also, remove the table pin (D, Fig. 5) found on the side of the table.
3. Slide saw blade through slot in table where the table pin was located. Rotate the table 90 degrees so that the miter slot is parallel to the blade, and to the right of the blade when facing the bandsaw.
4. Line up the trunnions so that the bolts feed through the trunnion support bracket. Secure the table with two lock knobs (C, Fig. 6). Reinstall the table insert and table pin.
5. Place a square (E, Fig. 5) on the table and against the back edge of the blade. If the table needs adjusted, on the low side, loosen two bolts (B, Fig. 5) and turn the setscrew (F, Fig. 5) until the table is approximately square to the back edge of the blade.

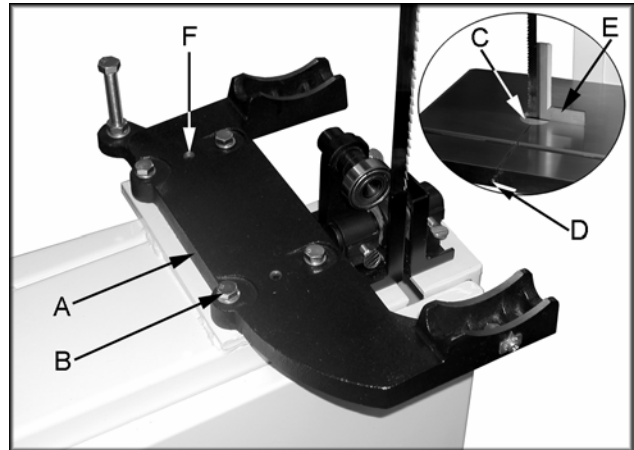

Figure 5

Adjusting 90 Degree Table Stop

1. Blade tension and tracking must be properly adjusted prior to table stop setup.
2. Loosen lock knobs (C, Fig. 6) and tilt table until it rests against table stop bolt (D, Fig. 6). Tighten knobs.
3. Use a square (G, Fig. 7) placed on the table and against the blade to see if the table is 90 degrees to the blade.
4. If an adjustment is necessary, loosen the lock knobs. Tilt the table until it is square to the blade, and tighten the lock knobs.
5. Loosen lock nut (E, Fig. 6) and turn table stop bolt (D, Fig. 6) until it contacts the table. Tighten the nut (E, Fig. 6) to hold table stop in place. When tightening the nut hold the table stop bolt in place with a wrench to prevent movement.
6. If necessary, adjust pointer (F, Fig. 6) to zero.

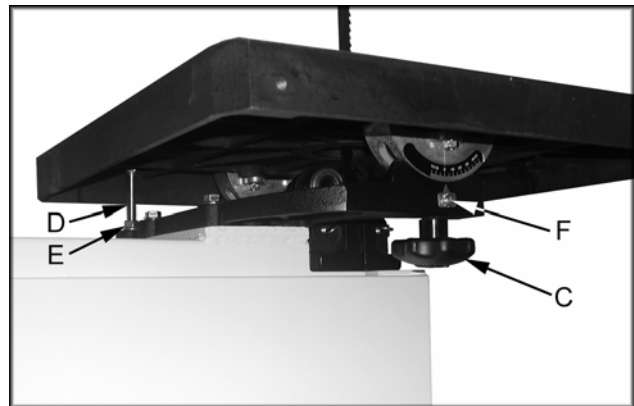

Figure 6

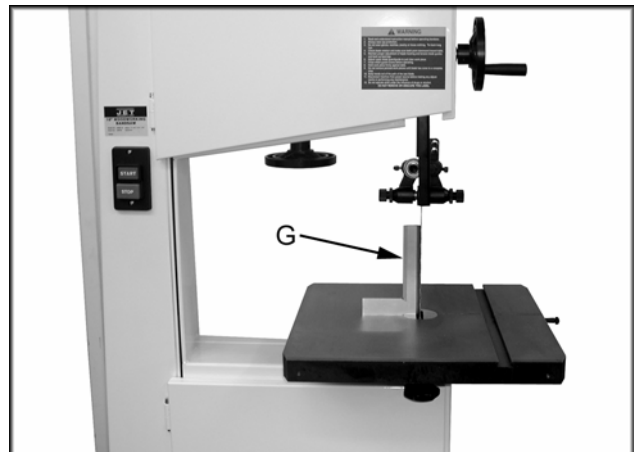

Figure 7

Rail Assembly (optional accessory)

1. Attach the front rail (A, Fig. 8) to the cast iron table with two 1/4" x 5/8" hex cap bolts, two 1/4" lock washers, and two 1/4" flat washers. Bolts should be in approximately the center of the slot. Hand tighten only at this time.
2. Attach the rear rail (B, Fig. 8) to the table with two 1/4" x 5/8" hex cap bolts, two 1/4" lock washers, and two 1/4" flat washers. Bolts should be in approximately the center of the slot. Hand tighten only at this time.
3. Push the front, and rear rails up as far as they will go.
4. Tighten the four hex cap bolts holding the front, and rear rails to the table. Do not over tighten the bolts.
5. Attach the guide tube (C, Fig. 8) to the front rail with five 1/4" x 5/8" hex cap bolts, five 1/4" lock washers, and five 1/4" flat washers. Bolts should be in approximately the center of the slot.

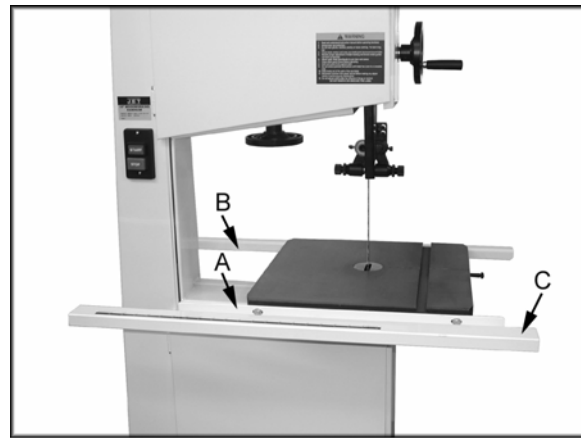

Figure 8

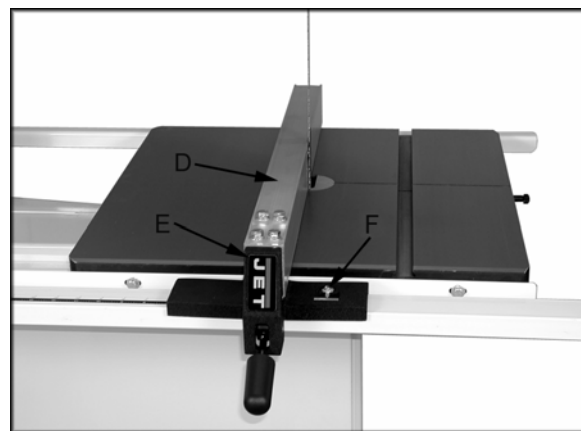

Figure 9

Fence Assembly and Adjustment (optional accessory)

1. Attach the fence (D, Fig. 9) to the fence body (E, Fig. 9) with four 5/16" x 3/4" hex cap bolts, four 5/16" lock washers, and four 5/16" flat washers.
2. Thread a hex nut (G, Fig. 10) onto the pad's threaded stud (H, Fig. 10) and insert through the fence and rear hook (I, Fig. 10). Secure in place using a hex nut, lock washer and flat washer (J, Fig. 10).

Note: The hook should be adjusted so that it overlaps the rear rail by approximately 1/8".

3. Place fence assembly onto the guide tube. The rear hook should engage the rear rail.

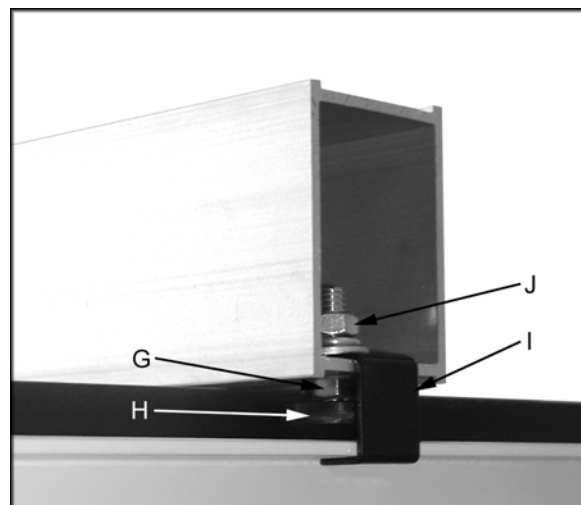

Figure 10

4. Check the clearance between the table and the fence. The gap should be the same at the front of the table as it is at the rear. If the gap width is different, adjust the foot at the rear of the fence until the gap width is the same, Figure 11.

Note: You can also adjust the front rail, or rear rail up, or down to achieve the proper clearance.

5. With a square verify the fence face is perpendicular to the table top. If it is not the front rail will need to be adjusted parallel to the table top. This can be accomplished by measuring from the top of the table to the top of the front rail. The measurement should be the same at both ends of the table.
6. Move the fence assembly so that it aligns parallel to the blade, and lock the fence by pushing the lock handle down.
7. Loosen the four hex cap bolts that hold the fence, to the fence body, and align the fence to the blade. Tighten the four hex cap bolts.
8. Check to see that the pointer (F, Fig. 9) is aligned with the zero marking on the guide rail. If adjustment is necessary loosen the screw that holds the pointer in place and line up to the zero mark. Tighten the screw.

Note: If you cannot get the pointer lined up with the zero mark you can slide the guide tube and front rail left, or right to achieve the proper setting.

Resaw Guide (optional accessory)

For resawing attach the post (A, Fig. 12) to fence with the lock knob (B, Fig. 12). There is a slotted hole in the fence that will accommodate the resaw kit. Position the post so that it is centered with the front edge of the blade. The resaw guide will give you a taller, single point contact surface during resawing.

Miter Gauge (optional accessory)

1. Place the miter gauge in the table slot.
2. With a square verify the miter gauge face is square to the blade.
3. If the miter gauge is not square to the blade loosen the lock knob (C, Fig. 12) and adjust to the proper setting. Tighten the lock knob.
4. If the pointer is not at 90 degrees, loosen the screw (D, Fig. 12) holding the pointer and move the pointer to 90 degrees.

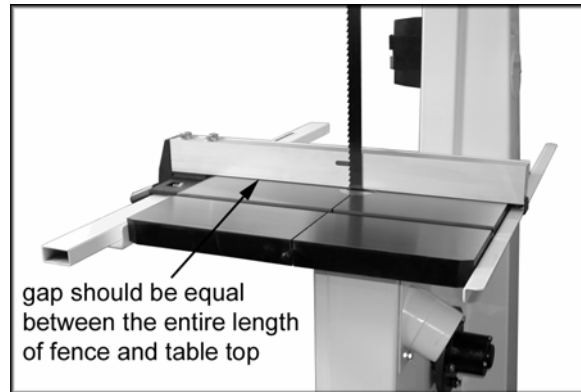

Figure 11

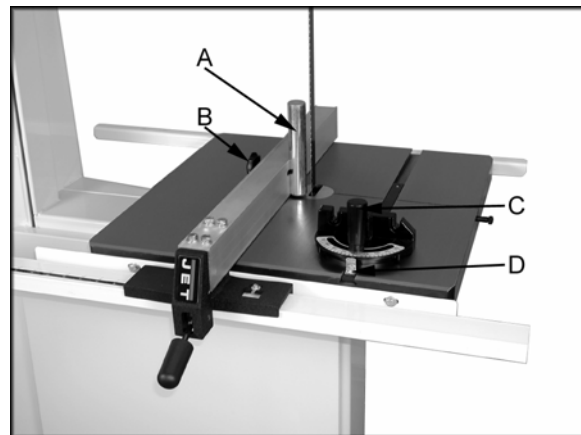

Figure 12

Tilting the Table

1. Disconnect the machine from the power source, unplug.
2. Loosen the lock knobs (A, Fig. 13).
3. Tilt table up to 45 degrees to the right, or up to 10 degrees to the left.
4. Tighten the lock knobs.

Note: Table stop bolt (B, Fig. 13) must be removed to tilt table to the left.

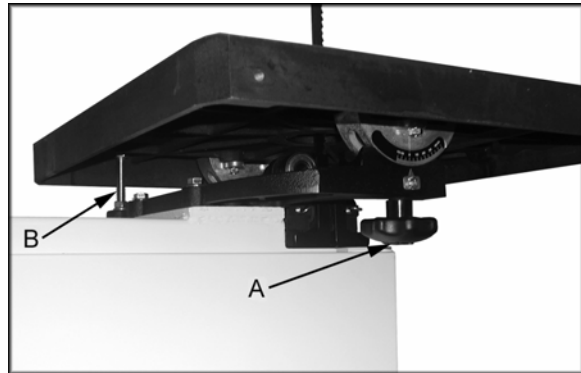

Figure 13

Height Scale Adjustment

1. Disconnect the machine from the power source, unplug.
2. The upper blade guide should be set about 1/8" above the material to be cut.
3. Measure from the table top to the bottom of the blade guides, Figure 14.
4. Set the indicator to this measurement on the height scale. Grasp the end of the indicator (C, Fig. 15) between your finger, and thumb. Move the indicator into position.

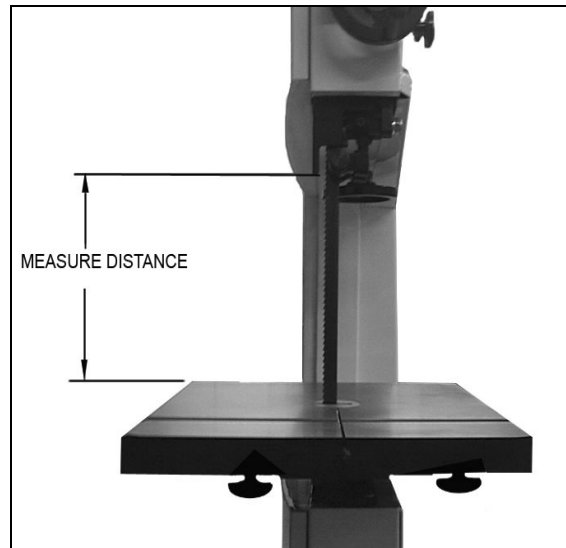

Figure 14

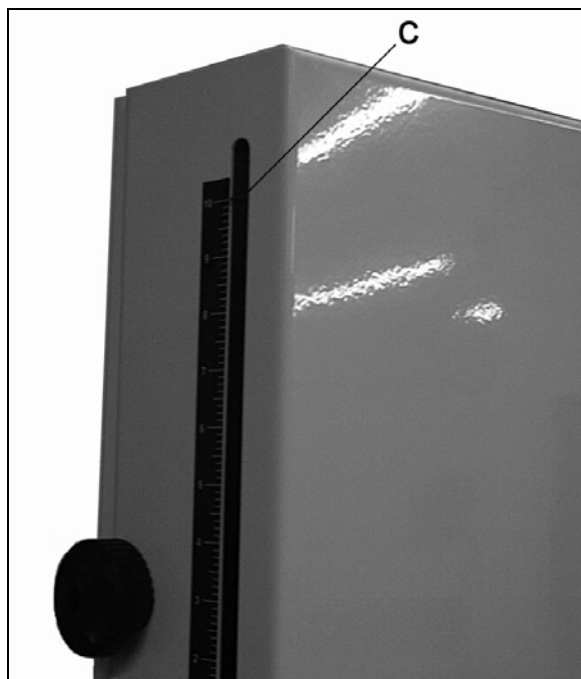

Figure 15

Changing Blades

⚠WARNING Disconnect machine from the power source, unplug! Blade teeth are sharp! Use care when handling the saw blade. Failure to comply may cause serious injury!

1. Remove the table insert (A, Fig. 16), and table pin (B, Fig. 16).
2. Lower the upper blade guide assembly about half way by loosening the lock knob (F, Fig. 17) and turning the hand wheel (G, Fig. 17).
3. Loosen socket head cap screw (C, Fig. 16) and slide the blade guide assembly back as far as it will go.
4. Open both wheel covers (D, Fig. 16).
5. Loosen blade tension by turning blade tension hand wheel (E, Fig. 17) clockwise until it stops.

Note: You may want to wear leather work gloves while removing and handling the blade.

6. Carefully remove blade from upper and lower wheels. Remove the blade from between upper, and lower blade guides. Turn blade and direct through slot in table.
7. Make sure blade teeth point down toward table and guide the new blade through table slot. Place blade in upper, and lower blade guides.
8. Place blade in the middle of the upper and lower wheels.
9. Tension and track blade before operating saw. Find instructions for tensioning and tracking the blade on page 10 under "Adjusting Blade Tension" and "Adjusting Blade Tracking".
10. Replace table insert and table pin.

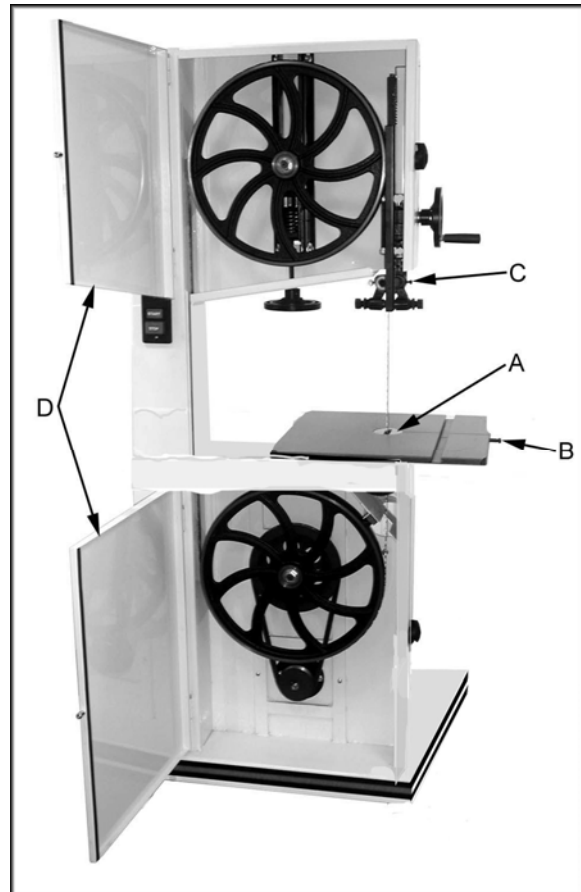

Figure 16

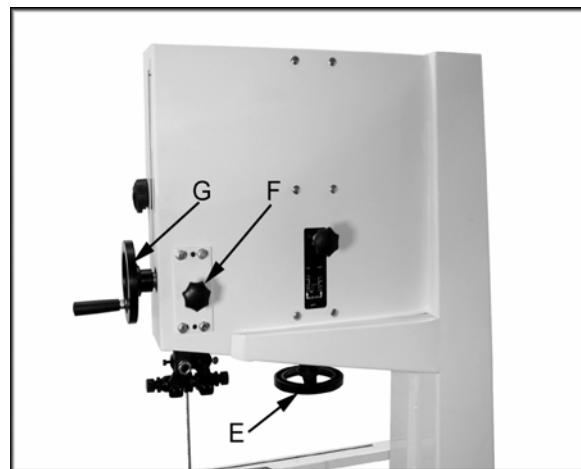

Figure 17

Replacing V-Belt

1. Disconnect the machine from the power source.
2. Release blade tension by turning blade tension hand wheel clockwise.
3. Release belt tension by loosening the two hex cap bolts (A, Fig. 19). Raise the motor and tighten hex cap bolts to take the tension off the belt.
4. Open the lower wheel door and remove hex nut, and washer (B, Fig. 20).
5. Remove the wheel (C, Fig. 21). If the lower wheel does not come off easily you may need to use a pulley puller to remove the lower wheel.
6. Remove the old belt (D, Fig. 21) and replace the belt.
7. Reinstall the lower wheel and tighten the hex nut.
8. Loosen hex cap bolts and adjust the belt tension. See "Adjusting the Belt Tension."
9. Set the blade tension. See "Adjusting Blade Tension" on page 10.
10. Check the blade tracking. See "Adjusting Blade Tracking" on page 10.



Figure 19

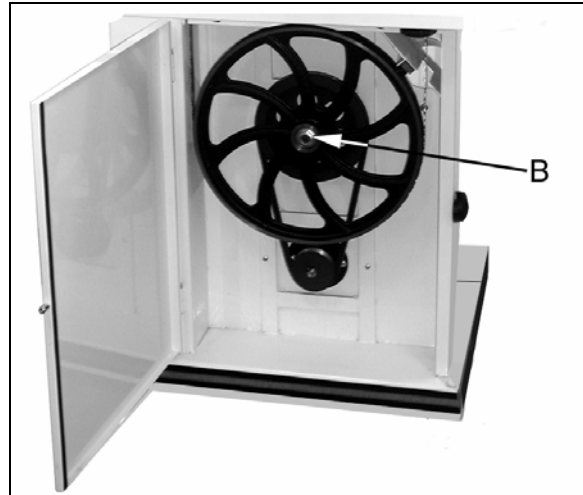

Figure 20

Adjusting Belt Tension

The belt comes adjusted from the factory. If adjustment is needed:

1. Disconnect the machine from the power source.
2. Loosen hex cap bolts (A, Fig. 19).
3. Set the belt tension by lightly pressing down on the motor and tightening the hex cap bolts (A, Fig. 19).

Note: The weight of the motor should put enough tension on the belt. You just want to push down lightly to take up any slack.

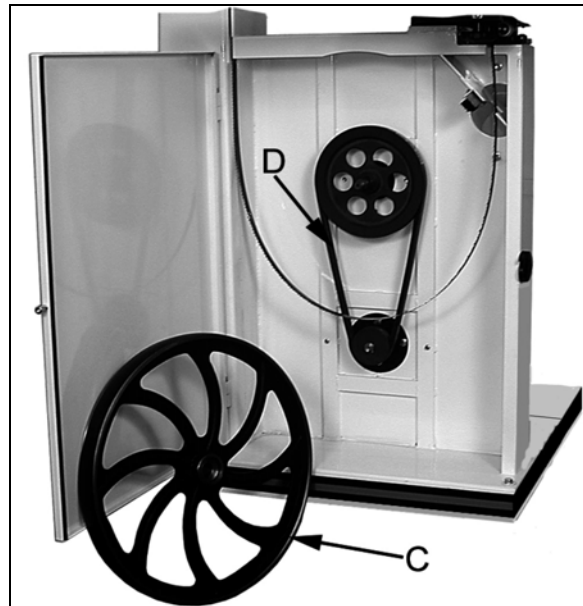

Figure 21

Electrical Connections

⚠WARNING All electrical connections must be done by a qualified electrician! Failure to comply may result in loss of property and/or serious injury!

The JWBS-16B is rated at 1-1/2 HP, 1Ph, 115V/230V, prewired 115V.

The bandsaw comes with a 115V plug (A, Fig. 22). If you switch the motor to 230V a plug needs to be purchased for the bandsaw that matches the 230V outlet you intend to use.

Confirm power at the site is the same as the saw before making any electrical connections. Review the wiring diagram on page 30.

Review the *Grounding Instructions, 115 Volt Operation*, and *230 Volt Operation* sections on page 7.

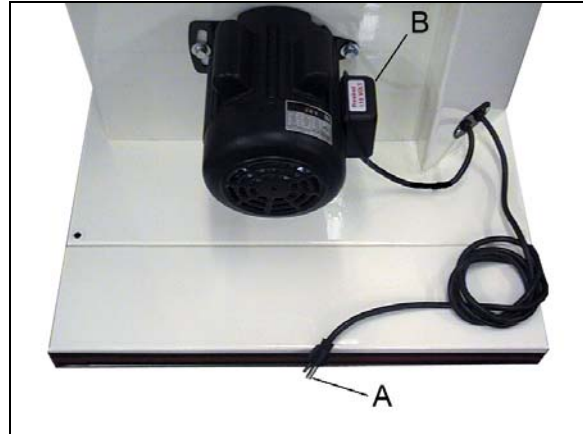

Figure 22

Maintenance

Keep blade guides clean and free of build up.

Do not let saw dust build up in the upper and lower wheel housings. Vacuum out frequently.

Connect the bandsaw to a JET dust collection system.

Clean and grease the raising/lowering rack for the upper blade guides if it becomes difficult to raise, or lower.

Clean, and oil the tensioning mechanism if it becomes difficult to adjust.

Vacuum out the motor fan cover.

Troubleshooting

| Trouble | Possible Cause | Solution |
|--|--|---|
| Saw stops or will not start | <ol style="list-style-type: none"> 1. Saw unplugged 2. Fuse blown or circuit breaker tripped 3. Cord damaged | <ol style="list-style-type: none"> 1. Check plug connections 2. Replace fuse or reset circuit breaker 3. Replace cord |
| Does not make accurate 45° or 90° cuts | <ol style="list-style-type: none"> 1. Stop not adjusted correctly 2. Angle pointer not set accurately 3. Miter gauge out of adjustment | <ol style="list-style-type: none"> 1. Check blade with square and adjust stop 2. Check blade with square and adjust pointer 3. Adjust miter gauge |
| Blade wanders during cut | <ol style="list-style-type: none"> 1. Fence not aligned with blade 2. Warped wood 3. Excessive feed rate 4. Incorrect blade for cut 5. Blade tension not set properly 6. Guides not set properly | <ol style="list-style-type: none"> 1. Check and adjust fence 2. Select another piece of wood 3. Reduce feed rate 4. Change blade to correct type 5. Set blade tension according to blade size 6. Review guide adjustment on pages 8 |
| Saw makes unsatisfactory cuts | <ol style="list-style-type: none"> 1. Dull blade 2. Blade mounted wrong 3. Gum or pitch on blade 4. Incorrect blade for cut 5. Gum or pitch on table | <ol style="list-style-type: none"> 1. Replace blade 2. Teeth should point down 3. Remove blade and clean 4. Change blade to correct type 5. Clean table |
| Blade does not come up to speed | <ol style="list-style-type: none"> 1. Extension cord too light or too long 2. Low shop voltage | <ol style="list-style-type: none"> 1. Replace with adequate size and length cord 2. Contact your local electric company |
| Saw vibrates excessively | <ol style="list-style-type: none"> 1. Base on uneven floor 2. Bad V-belt 3. Motor mount is loose 4. Loose hardware | <ol style="list-style-type: none"> 1. Reposition on flat, level surface 2. Replace V-belt 3. Tighten motor mount hardware 4. Tighten hardware |

Parts

Replacement Parts

Replacement parts are listed on the following pages. To order parts or reach our service department, call 800-274-6848 between 7:30 a.m. and 5:30 p.m. (CST), Monday through Friday. Having the Model Number and Serial Number of your machine available when you call will allow us to serve you quickly and accurately.

Upper Wheel Assembly

| Index No. | Part No. | Description | Size | Qty |
|-----------|---------------|-------------------------|-------------------------------|-----|
| 1 | JWBS16B-101 | Saw Body | | 1 |
| 2 | TS-0152011 | Carriage Bolt | 5/16-18x1 | 6 |
| 3 | JWBS18-103 | Upper Wheel Bracket | | 2 |
| 4 | TS-0680031 | Flat Washer | 5/16 | 6 |
| 5 | TS-0720081 | Lock Washer | 5/16 | 6 |
| 6 | TS-0561021 | Hex Nut | 5/16-18 | 6 |
| 7 | 994542 | Switch | | 1 |
| 8 | JWBS18-108 | Hex Cap Bolt | M8x65 | 1 |
| 9 | TS-0680021 | Flat Washer | 1/4 | 4 |
| 10 | JWBS18-110 | Sliding Bracket | | 1 |
| 11 | JWBS18-111 | Blade Tension Indicator | | 1 |
| 12 | JWBS18-112 | Adjustment Bracket | | 1 |
| 13 | JWBS18-113 | Shaft Bracket | | 1 |
| 14 | TS-1541031 | Nylon Insert Lock Nut | M8 | 1 |
| 15 | JWBS18-115 | Spring | | 1 |
| 16 | JWBS18-116 | Square Nut | | 1 |
| 17 | JWBS18-117 | Pointer | | 1 |
| 18 | JWBS18-118 | Screw | M5x8 | 1 |
| 19 | JWBS18-119 | Set Block | | 1 |
| 20 | TS-0267021 | Set Screw | 1/4-20x1/4 | 1 |
| 21 | JWBS18-121 | Bracket | | 1 |
| 22 | TS-0050021 | Hex Cap Screw | 1/4-20x5/8 | 4 |
| 23 | JWBS16-123 | Blade Adjusting Screw | | 1 |
| 24 | JWBS18-124 | E-Ring | E-9 | 1 |
| 25 | JWBS18-125 | Hand Wheel | | 1 |
| 26 | TS-0267041 | Socket Set Screw | 1/4-20x3/8 | 3 |
| 27 | TS-0209021 | Socket Head Cap Screw | 3/8-16x5/8 | 1 |
| 28 | TS-0720091 | Lock Washer | 3/8 | 1 |
| 29 | JWBS18-129 | Upper Wheel Shaft | | 1 |
| 30 | BB-6203ZZ | Ball Bearing | 6203ZZ | 2 |
| 31 | JWBS18-131 | Retaining Ring | R40 | 2 |
| 32 | JWBS16-132 | Upper Wheel | | 1 |
| 33 | JWBS16-133 | Tire | | 1 |
| 34 | JWBS18-134 | Flat Washer | | 1 |
| 35 | JWBS18-135 | Hex Nut | 5/8-18UNF L.H. | 1 |
| 36 | JWBS16B-136 | Blade | 3/4"W x 123"L x .026"T x 4TPI | 1 |
| 37 | TS-0590061 | Wing Nut | 5/16-18 | 1 |
| 38 | JWBS18-138 | Lock Knob | 5/16 | 1 |
| 39 | JWBS16B-139 | Upper Front Door | | 1 |
| 40 | JWBS18-140 | JET Plaque | | 1 |
| 41 | JWBS18-141 | Warning Label | | 1 |
| 42 | JWBS18-142 | Bolt | | 1 |
| 43 | TS-0561011 | Hex Nut | 1/4-20 | 1 |
| 44 | TS-081C022 | Pan Head Machine Screw | #10-24x3/8 | 2 |
| 45 | JWBS18-39A | Door Hinge Pin | | 1 |
| 46 | JWBS18DXA-163 | Blade Warning Label | | 1 |
| 47 | TS-1550061 | Flat Washer | M8 | 2 |

Upper Wheel Assembly

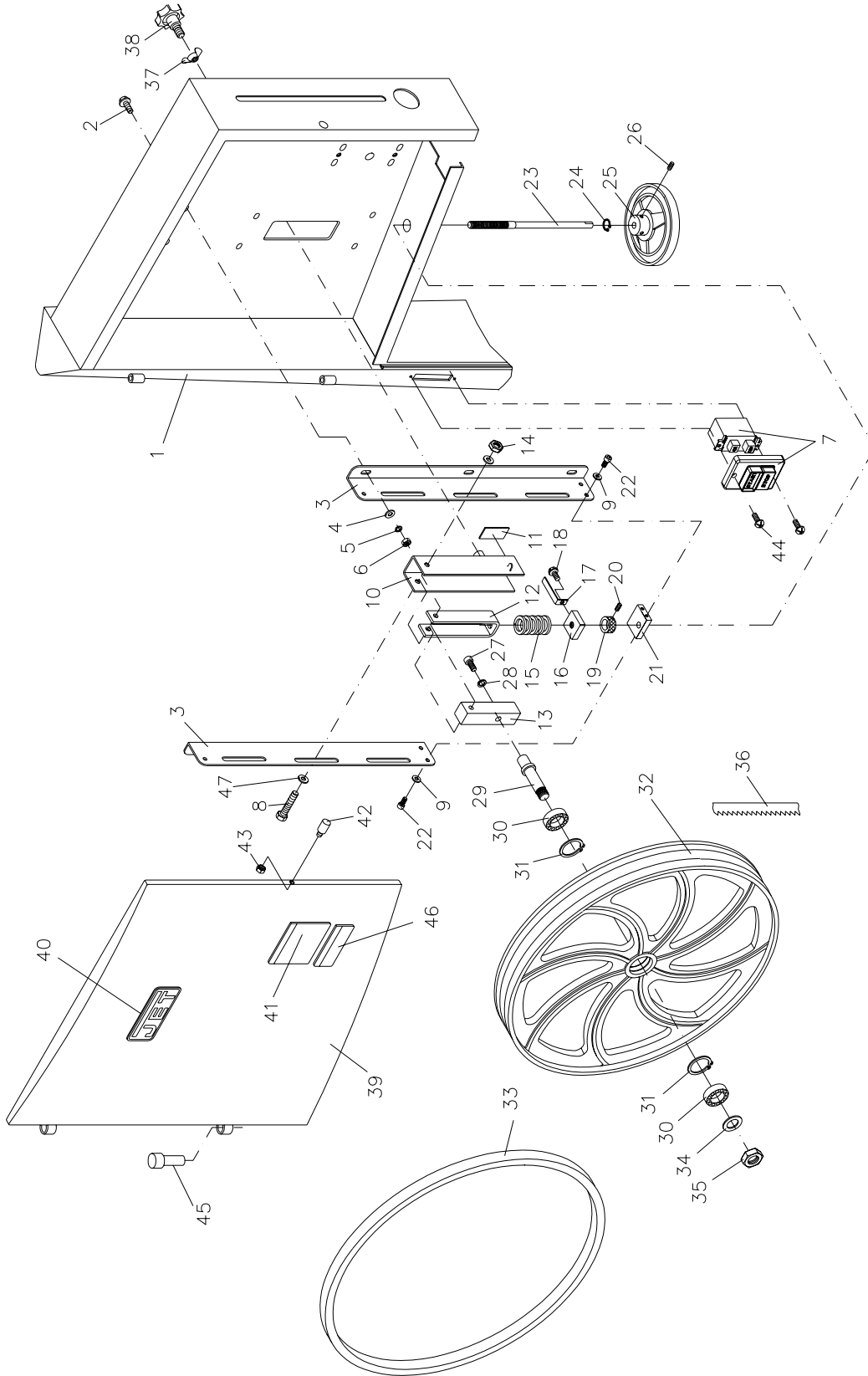

Lower Wheel and Motor Assembly

| Index No. | Part No. | Description | Size | Qty |
|-----------|-------------|--------------------------------------|----------------|-----|
| 1 | JWBS18-201N | Bearing Base | | 1 |
| 2 | JWBS20-62 | Adjusting Bolt | | 4 |
| 3 | TS-0720091 | Lock Washer | 3/8 | 4 |
| 4 | TS-0060081 | Hex Cap Screw | 3/8-16x1-3/4 | 4 |
| 5 | BB-6204ZZ | Ball Bearing | 6204ZZ | 1 |
| 6 | JWBS18-206N | Spindle | | 1 |
| 7 | JWBS18-207 | Key | 7x7x40 | 1 |
| 8 | JWBS18-208N | Spindle Pulley | | 1 |
| 9 | VB-B40 | V-Belt | B-40 | 1 |
| 10 | JWBS16-210 | Lower Wheel | | 1 |
| 11 | JWBS16-133 | Tire | | 1 |
| 12 | TS-0680081 | Flat Washer | 5/8 | 1 |
| 13 | JWBS18-135 | Hex Nut | 5/8-18UNF L.H. | 1 |
| 14 | JWBS18-214 | Hex Nut | 5/8-18UNF R.H. | 1 |
| 15 | JWBS18-215 | Bearing Cover | | 1 |
| 16 | TS-0720051 | Lock Washer | #10 | 3 |
| 17 | TS-081C022 | Pan Head Machine Screw | #10-24x3/8 | 3 |
| 18 | JWBS16-218 | Motor | | 1 |
| | JWBS16-SC | Starting Capacitor (not shown) | 200MFD, 125VAC | 1 |
| | JWBS16-RC | Running Capacitor (not shown) | 16µF, 250V | 1 |
| | JWBS16-SCC | Starting Capacitor Cover (not shown) | | 1 |
| | JWBS16-RCC | Running Capacitor Cover (not shown) | | 1 |
| | JWBS18-FAN | Fan | | 1 |
| | JWBS18-CS | Centrifugal Switch (not shown) | | 1 |
| | JWBS16-MFC | Motor Fan Cover (not shown) | | 1 |
| 19 | JWBS18-219 | Motor Bracket | | 1 |
| 20 | TS-0081031 | Hex Cap Screw | 5/16-18x3/4 | 4 |
| 21 | TS-0680031 | Flat Washer | 5/16 | 4 |
| 22 | TS-0060051 | Hex Cap Screw | 3/8-16x1 | 2 |
| 23 | TS-0720091 | Lock Washer | 3/8 | 2 |
| 24 | TS-0680041 | Flat Washer | 3/8 | 2 |
| 25 | JWBS16-225 | Motor Pulley | | 1 |
| 26 | TS-0270031 | Socket Set Screw | 5/16-18x3/8 | 2 |
| 27 | JWBS16B-227 | Lower Front Door | | 1 |
| 28 | JWBS18-142 | Bolt | | 1 |
| 29 | TS-0561011 | Hex Nut | 1/4-20 | 1 |
| 30 | JWBS20-2 | Lock Knob | | 1 |
| 31 | TS-081F052 | Pan Head Machine Screw | 1/4-20x3/4 | 1 |
| 32 | JWBS20-8W | Dust Chute | | 1 |
| 33 | TS-0680031 | Flat Washer | 5/16 | 2 |
| 34 | TS-0051051 | Hex Cap Screw | 5/16-18x1 | 2 |
| 35 | JWBS18-235 | Plate | | 1 |
| 36 | TS-081C032 | Pan Head Machine Screw | #10-24x1/2 | 2 |
| 37 | JWBS18-237 | Strain Relief Bushing | | 2 |
| 38 | TS-081C082 | Pan Head Machine Screw | #10-24x1-1/2 | 2 |
| 39 | TS-069204 | Flat Washer | #10 | 2 |
| 40 | JWBS18-240 | Brush | | 1 |
| 41 | TS-0720051 | Lock Washer | #10 | 2 |
| 42 | TS-0560071 | Hex Nut | #10-24 | 2 |
| 43 | JWBS18-243 | Motor Cord | | 1 |
| 44 | JWBS18-244 | Power Cord | | 1 |
| 45 | BB-6205ZZ | Ball Bearing | 6205ZZ | 1 |
| 46 | JWBS16B-246 | I.D. Label | | 1 |
| 48 | JWBS18-39A | Door Hinge Pin | | 2 |
| 49 | JWBS16B-249 | Base Support Foot | | 1 |
| 50 | JWBS16B-250 | Support Plate | | 2 |
| 51 | TS-0255011 | Button Head Socket Screw | 5/16-18x3/8 | 8 |

Lower Wheel and Motor Assembly

| Index No. | Part No. | Description | Size | Qty |
|-----------|------------|-------------|---------|-----|
| 52 | TS-0680031 | Flat Washer | 5/16 | 8 |
| 53 | TS-0720081 | Lock Washer | 5/16 | 2 |
| 54 | TS-0561021 | Hex Nut | 5/16-18 | 2 |

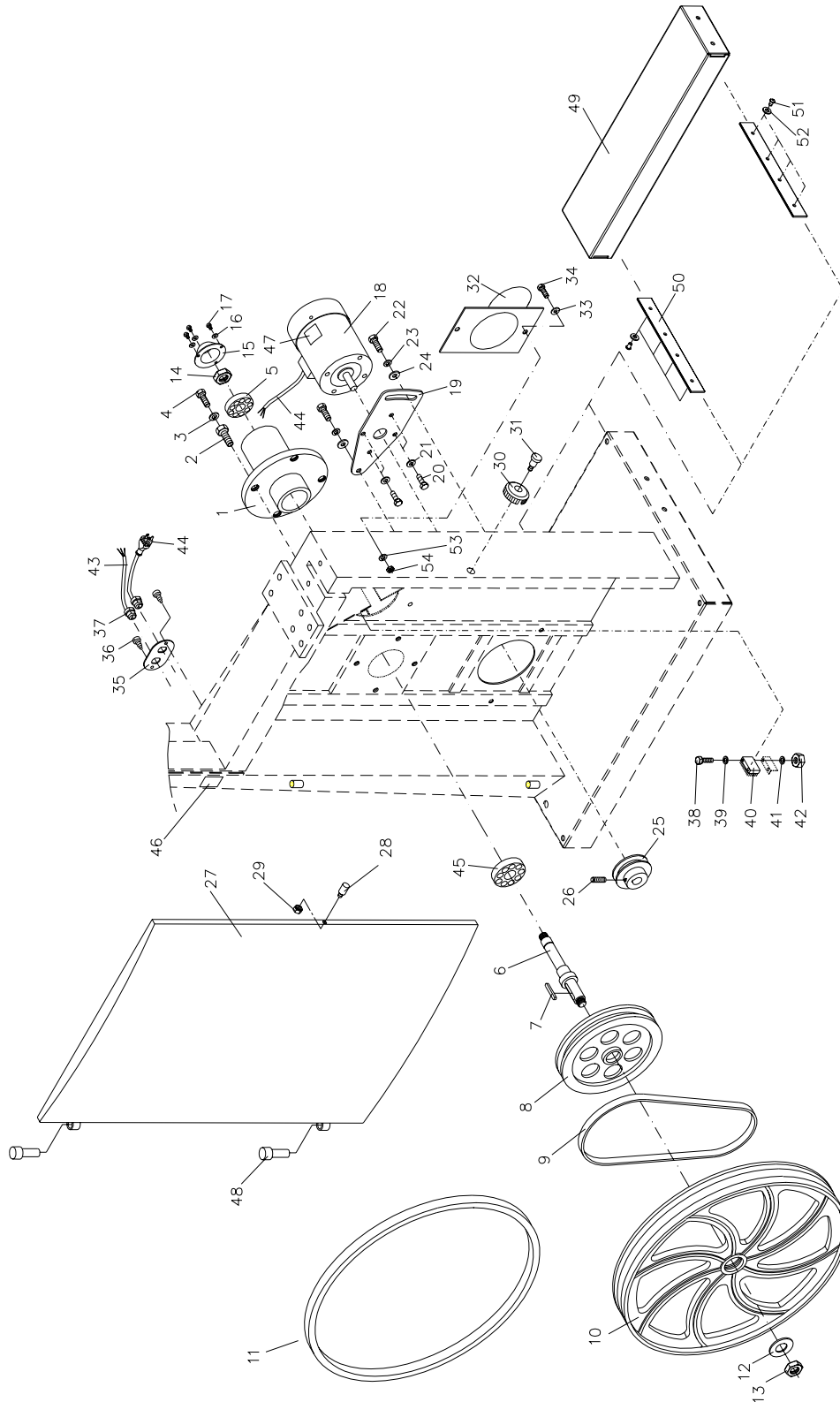

Blade Guides Assembly

| Index No. | Part No. | Description | Size | Qty |
|-----------|---------------|--------------------------------|---------------|-----|
| 1 | TS-0051051 | Hex Cap Screw | 5/16-18x1 | 4 |
| 2 | TS-0720081 | Lock Washer | 5/16 | 4 |
| 3 | TS-0680031 | Flat Washer | 5/16 | 8 |
| 4 | JWBS18-304 | Guide Bar Bracket | | 1 |
| 5 | JWBS18-305 | Worm | | 1 |
| 6 | JWBS18-306 | E-Ring | E-8 | 2 |
| 7 | JWBS18-307 | Gear Base | | 1 |
| 8 | JWBS18-308 | Bushing | | 1 |
| 9 | JWBS18-309 | C-Ring | S-12 | 2 |
| 10 | JWBS18-310 | Shaft | | 1 |
| 11 | JWBS18-311 | Gear | | 1 |
| 12 | TS-0208071 | Socket Head Cap Screw | 5/16-18x1-1/4 | 2 |
| 13 | JWBS18-313 | Lock Knob | 5/16 | 1 |
| 14 | JWBS18-314 | Plate | | 1 |
| 15 | TS-0051011 | Hex Cap Screw | 5/16-18x1/2 | 4 |
| 16 | JWBS18-316 | Guide Bar | | 1 |
| 17 | JWBS16B-317 | Pointer | | 1 |
| 18 | TS-0720071 | Lock Washer | 1/4 | 5 |
| 19 | TS-0050011 | Hex Cap Screw | 1/4-20x1/2 | 1 |
| 20 | JWBS18-320 | Guide Bracket | | 1 |
| 21 | TS-0207021 | Socket Head Cap Screw | 1/4-20x1/2 | 11 |
| 22 | JWBS18-322 | Blade Guard | | 1 |
| 23 | TS-0720111 | Lock Washer | 1/2 | 1 |
| 24 | TS-0561051 | Hex Nut | 1/2-13 | 1 |
| 25 | JWBS20-110 | Locking Shaft | | 1 |
| 26 | JWBS20-115 | Upper Guide Bracket | | 1 |
| 27 | JWBS20-114 | Guide Wheel Assembly | | 2 |
| 28 | JWBS20-113 | Blade Support Shaft w/ Bearing | | 2 |
| 29 | JWBS18DXA-353 | Wing Screw | 1/4-20x1/2 | 4 |
| 30 | TS-0270031 | Socket Set Screw | 5/16-18x3/8 | 2 |
| 31 | JWBS20-2 | Lock Knob | | 1 |
| 32 | TS-081F052 | Pan Head Machine Screw | 1/4-20x3/4 | 1 |
| 33 | JWBS18-333 | Hand Wheel | | 1 |
| 34 | TS-0267041 | Socket Set Screw | 1/4-20x3/8 | 1 |
| 35 | JWBS20-103A | Handle | | 1 |
| 36 | JWBS16B-336 | Cutting Height Scale | | 1 |
| 37 | JWBS20-120 | Lower Guide Bracket | | 1 |
| 38 | JWBS18-338 | Lower Guide Wheel Housing | | 2 |
| 39 | JWBS18-339 | Lower Guide Wheel Assembly | | 2 |
| 40 | TS-0207031 | Socket Head Cap Screw | 1/4-20x5/8 | 2 |
| 41 | TS-0680021 | Flat Washer | 1/4 | 4 |
| 42 | JWBS18-342 | Lower Blade Guard | | 1 |
| 43 | TS-0254021 | Button Head Socket Screw | 1/4-20x1/2 | 2 |

Blade Guides Assembly

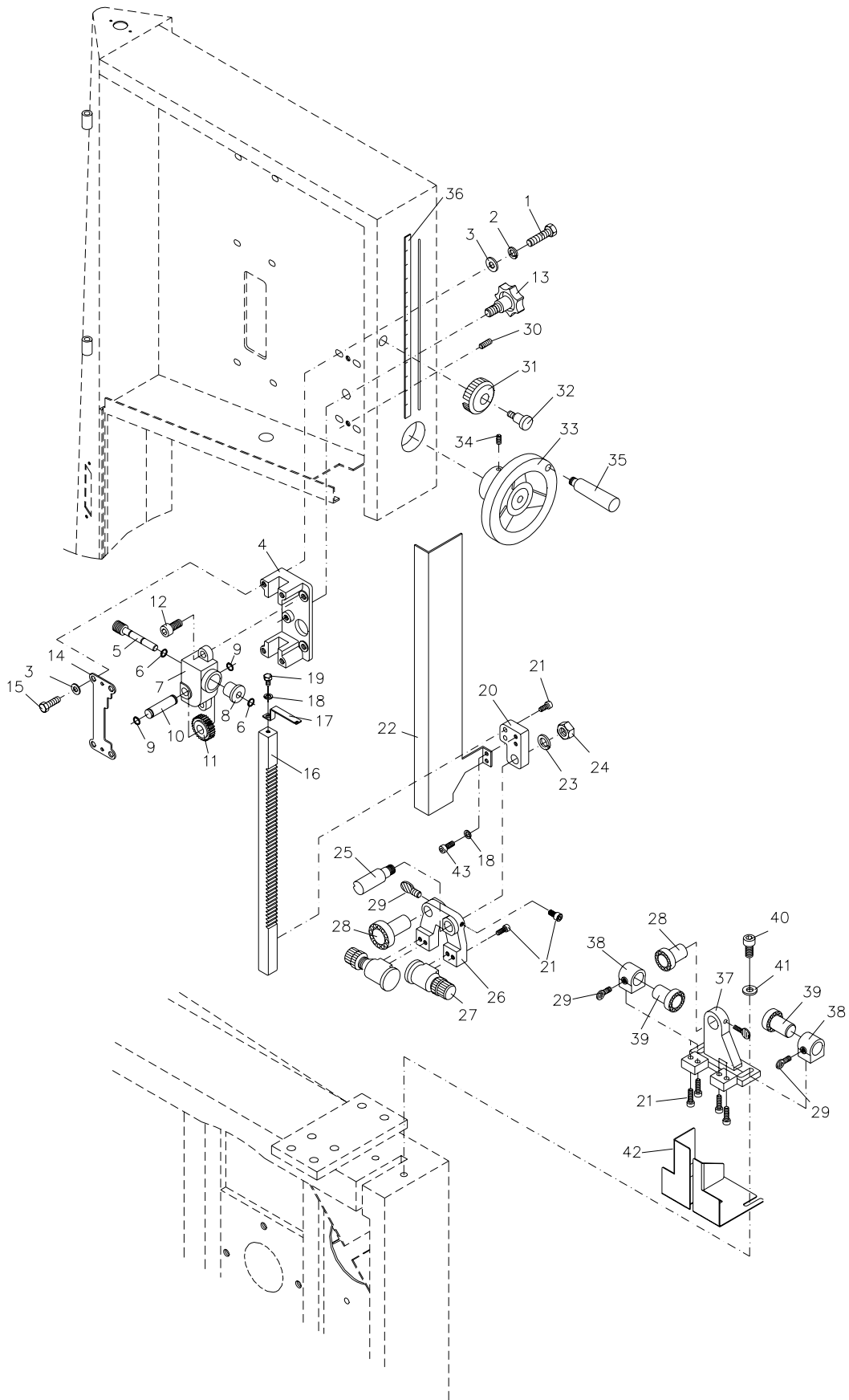
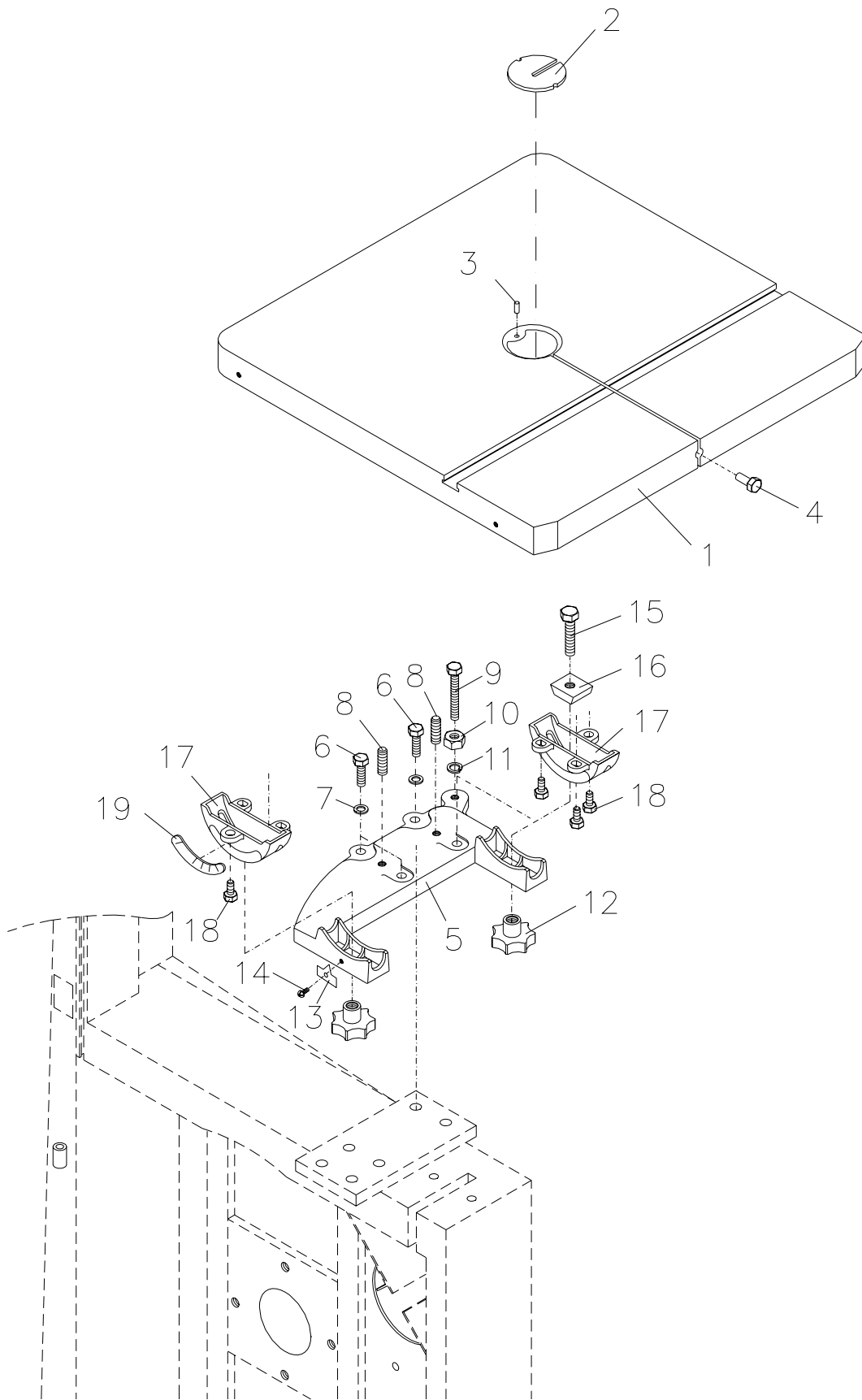

Table Assembly

| Index No. | Part No. | Description | Size | Qty |
|-----------|-------------|--------------------------|---------------|-----|
| 1 | JWBS16-401 | Table | | 1 |
| 2 | JWBS20-144 | Table Insert | | 1 |
| 3 | JWBS20-145 | Roll Pin | Ø3x10 | 1 |
| 4 | JWBS18-448 | Table Pin | | 1 |
| 5 | JWBS18-408N | Trunnion Support Bracket | | 1 |
| 6 | TS-0051071 | Hex Cap Screw | 5/16-18x1-1/2 | 4 |
| 7 | TS-0720081 | Lock Washer | 5/16 | 4 |
| 8 | TS-0270061 | Set Screw | 5/16-18x5/8 | 2 |
| 9 | TS-0060111 | Hex Cap Screw | 3/8-16x2-1/2 | 1 |
| 10 | TS-0561031 | Hex Nut | 3/8 | 1 |
| 11 | TS-0720091 | Lock Washer | 3/8 | 1 |
| 12 | JWBS18-415 | Lock Knob | | 2 |
| 13 | JWBS18-446 | Pointer | | 1 |
| 14 | JWBS18-447 | Screw | M5x8 | 1 |
| 15 | TS-1491081 | Hex Cap Screw | M10x50 | 2 |
| 16 | JWBS18-417 | Trunnion Clamp Shoe | | 2 |
| 17 | JWBS18-416 | Trunnion | | 2 |
| 18 | TS-1482021 | Hex Cap Screw | M6x12 | 6 |
| 19 | JWBS18-420 | Scale | | 1 |

Table Assembly



Fence & Miter Assembly (optional accessory)

| Index No. | Part No. | Description | Size | Qty |
|-----------|-------------|----------------------------|-------------|-----|
| 1 | JWBS18-401 | Lock Knob | | 1 |
| 2 | TS-0680021 | Flat Washer | 1/4 | 11 |
| 3 | JWBS18-403 | Miter Gauge Body | | 1 |
| 4 | 200156 | Guide Disc | | 1 |
| 5 | JWBS18-405 | Screw | M6x8 | 1 |
| 6 | JWBS18-406 | Pointer | | 1 |
| 7 | JWBS18-407 | Guide Bar | | 1 |
| 10 | TS-0720081 | Lock Washer | 5/16 | 4 |
| 22 | JWBS18-422W | Front Rail | | 1 |
| 23 | TS-0050021 | Hex Cap Screw | 1/4-20x5/8 | 9 |
| 24 | TS-0720071 | Lock Washer | 1/4 | 10 |
| 25 | JWBS18-425 | Scale | | 1 |
| 26 | JWBS18-426W | Guide Rail | | 1 |
| 27 | JWBS18-427W | Rear Rail | | 1 |
| 30 | JWBS18-430 | Fence Body | | 1 |
| 31 | JWBS18-431 | Knob | | 1 |
| 32 | JWBS18-432 | Lock Handle | | 1 |
| 33 | JWBS18-433W | Lock Plate | | 1 |
| 34 | JWBS18-434 | Pad | | 5 |
| 35 | JWBS18-435 | Pin | | 1 |
| 36 | JWBS18-436 | Pin | | 1 |
| 37 | JWBS16-437 | Fence | | 1 |
| 38 | TS-0081031 | Hex Cap Screw | 5/16-18x3/4 | 4 |
| 39 | TS-0680031 | Flat Washer | 5/16 | 4 |
| 40 | TS-0810012 | Screw | #10-24x1/4 | 2 |
| 41 | TS-0733031 | External Tooth Lock Washer | #10 | 1 |
| 42 | JWBS18-442 | Pointer | | 1 |
| 43 | TS-0561011 | Hex Nut | 1/4-20 | 2 |
| 44 | JWBS18-444 | Sliding Pad | | 1 |
| 45 | JWBS18-445 | Rear Hook | | 1 |
| 49 | JWBS18-449 | Resaw Post | | 1 |
| 50 | JWBS18-450 | Knob | | 1 |
| 51 | JWBS18-451 | JET Fence Label | | 1 |
| 52 | JWBS20-455 | End Cover | | 2 |
| | JWBS18-MGCP | Miter Gauge Assembly | | |
| | JWBS16-FCP | Fence Assembly Complete | | |

Fence & Miter Assembly (optional accessory)

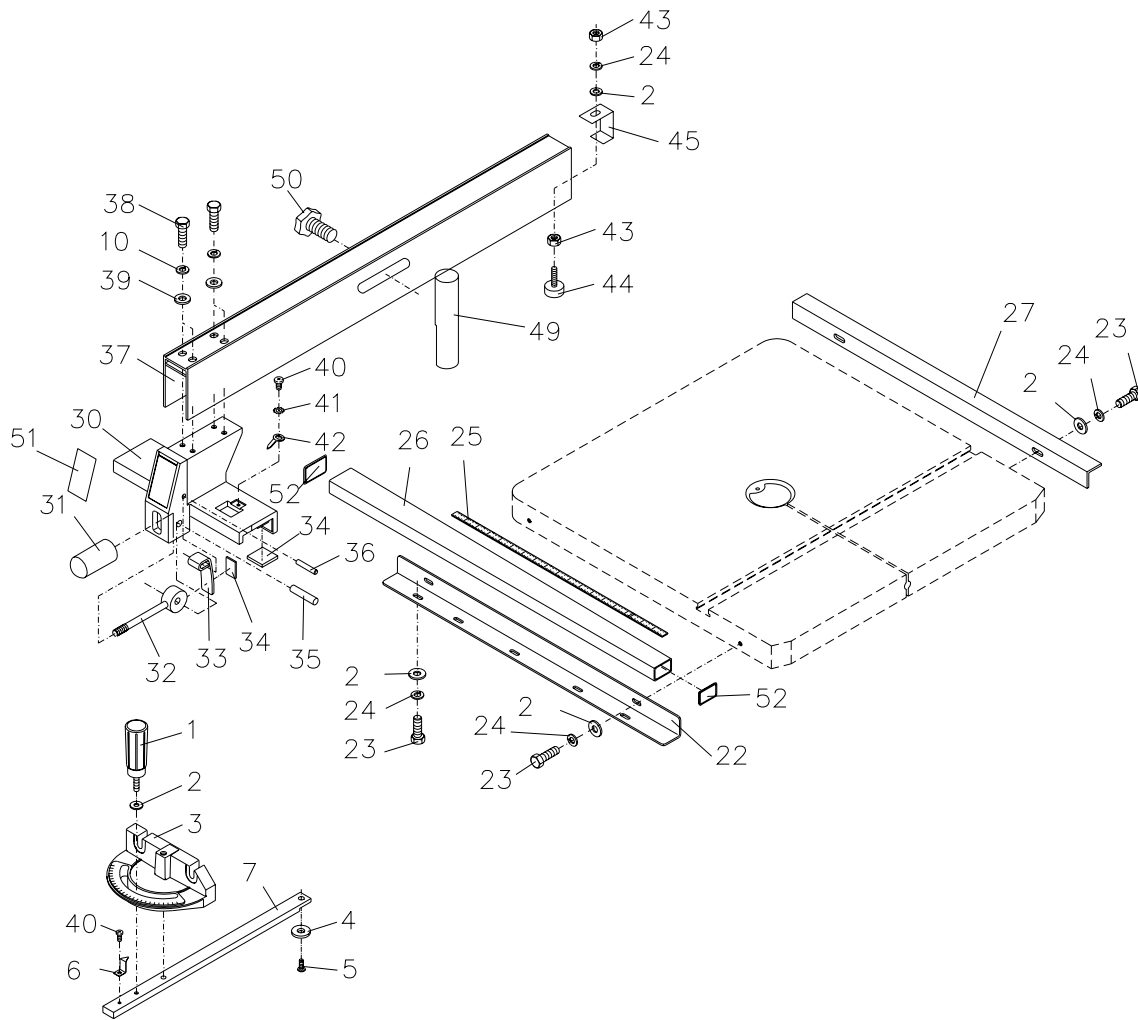

Wiring Diagram

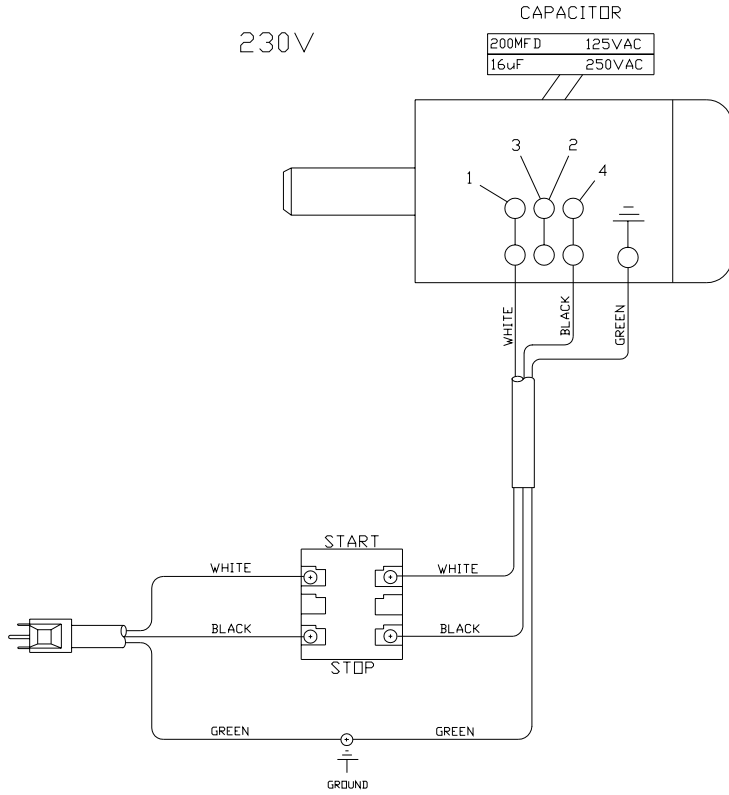
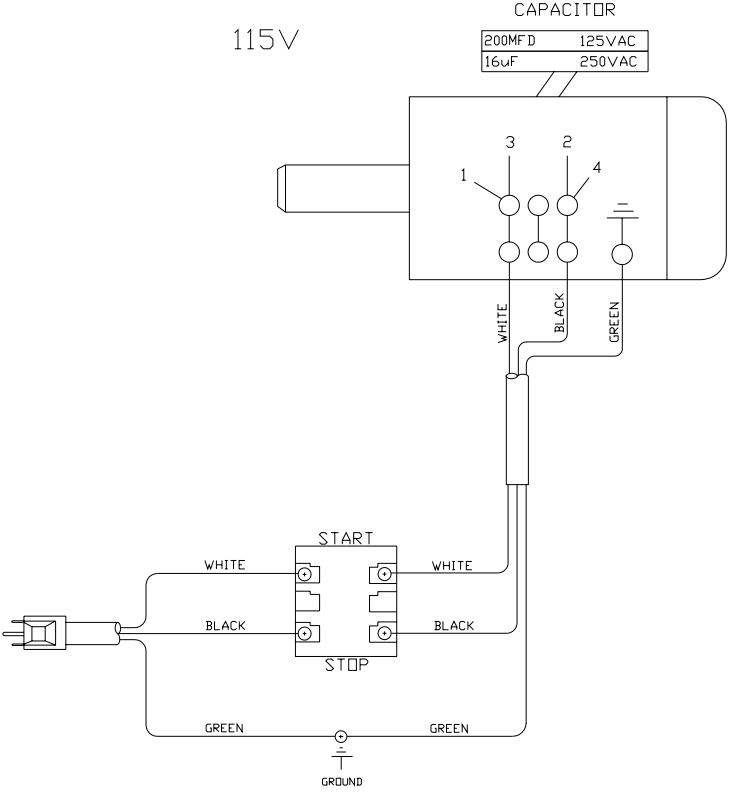

Notes

J E T[®]
WMH Tool Group, Inc.
2420 Vantage Drive
Elgin, Illinois 60124
Phone: 800-274-6848
www.wmhtoolgroup.com

Free Manuals Download Website

<http://myh66.com>

<http://usermanuals.us>

<http://www.somanuals.com>

<http://www.4manuals.cc>

<http://www.manual-lib.com>

<http://www.404manual.com>

<http://www.luxmanual.com>

<http://aubethermostatmanual.com>

Golf course search by state

<http://golfingnear.com>

Email search by domain

<http://emailbydomain.com>

Auto manuals search

<http://auto.somanuals.com>

TV manuals search

<http://tv.somanuals.com>