

POWERMATIC®

Operating Instructions and Parts Manual Powered Stock Feeder for Table Saws Model PF3-EZ

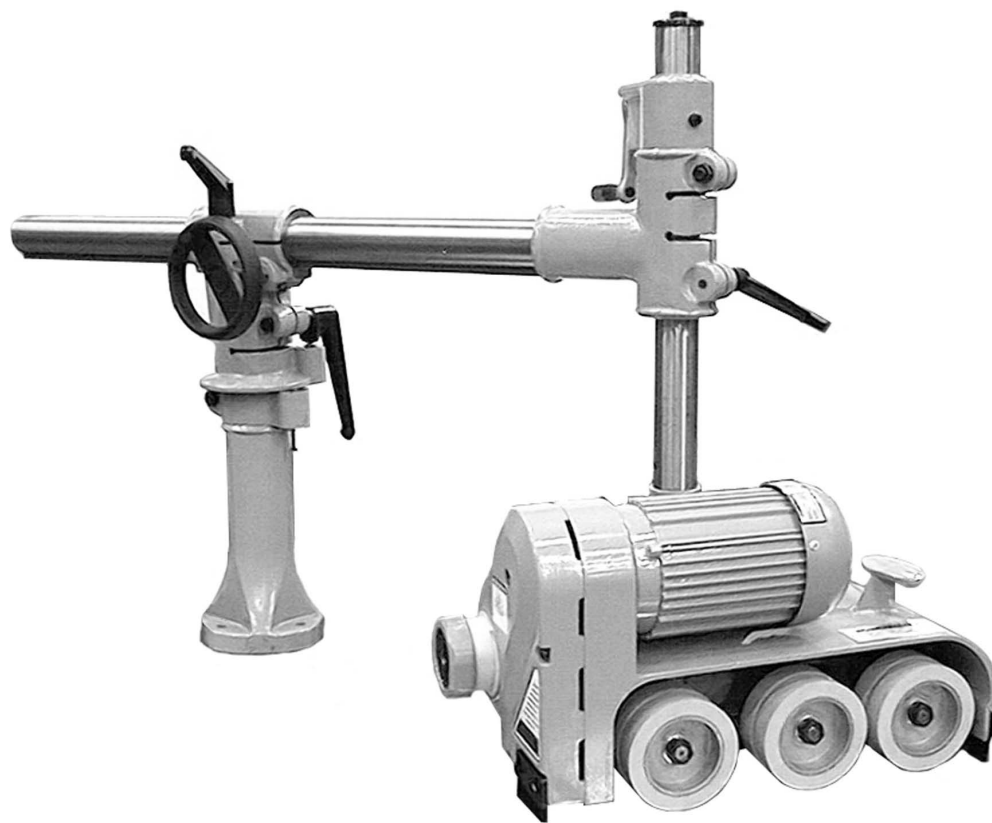

WMH TOOL GROUP, Inc.

2420 Vantage Drive
Elgin, Illinois 60123
Ph.: 800-274-6848
www.powermatic.com

Part No. M-1790814

Revision B 3/08

Copyright © 2008 WMH Tool Group

Warranty and Service



WMH Tool Group, Inc., warrants every product it sells. If one of our tools needs service or repair, one of our Authorized Service Centers located throughout the United States can give you quick service. In most cases, any of these WMH Tool Group Authorized Service Centers can authorize warranty repair, assist you in obtaining parts, or perform routine maintenance and major repair on your POWERMATIC® tools. For the name of an Authorized Service Center in your area call 1-800-274-6848.

MORE INFORMATION

WMH Tool Group is consistently adding new products to the line. For complete, up-to-date product information, check with your local WMH Tool Group distributor, or visit powermatic.com.

WARRANTY

POWERMATIC products carry a limited warranty which varies in duration based upon the product.

	Industrial Products Horizontal Panel Saws Cut Off Saws Rip Saws Bandsaws Jointers Planers Oscillating Edge Sanders Belt Sanders Shapers Power Feeders Mortisers Dovetailers		Non-Industrial Products Tablesaws Vertical Panel Saws Bandsaws Jointers Planers Planer/Molder Dust Collection Disc Sanders Edge Sanders Drum Sanders Shapers Drill Press's Mortisers Dovetailers
---	--	--	---

Warranty reverts to 1 Year if above products are used for commercial, industrial or educational purposes

WHAT IS COVERED?

This warranty covers any defects in workmanship or materials subject to the exceptions stated below. Cutting tools, abrasives and other consumables are excluded from warranty coverage.

WHO IS COVERED?

This warranty covers only the initial purchaser of the product.

WHAT IS THE PERIOD OF COVERAGE?

The general POWERMATIC warranty lasts for the time period specified in the product literature of each product.

WHAT IS NOT COVERED?

The Five Year Warranty does not cover products used for commercial, industrial or educational purposes. Products with a Five Year Warranty that are used for commercial, industrial or education purposes revert to a One Year Warranty. This warranty does not cover defects due directly or indirectly to misuse, abuse, negligence or accidents, normal wear-and-tear, improper repair or alterations, or lack of maintenance.

HOW TO GET SERVICE

The product or part must be returned for examination, postage prepaid, to a location designated by us. For the name of the location nearest you, please call 1-800-274-6848.

You must provide proof of initial purchase date and an explanation of the complaint must accompany the merchandise. If our inspection discloses a defect, we will repair or replace the product, or refund the purchase price, at our option.

We will return the repaired product or replacement at our expense unless it is determined by us that there is no defect, or that the defect resulted from causes not within the scope of our warranty in which case we will, at your direction, dispose of or return the product. In the event you choose to have the product returned, you will be responsible for the handling and shipping costs of the return.

HOW STATE LAW APPLIES

This warranty gives you specific legal rights; you may also have other rights which vary from state to state.

LIMITATIONS ON THIS WARRANTY

WMH TOOL GROUP LIMITS ALL IMPLIED WARRANTIES TO THE PERIOD OF THE LIMITED WARRANTY FOR EACH PRODUCT. EXCEPT AS STATED HEREIN, ANY IMPLIED WARRANTIES OR MERCHANTABILITY AND FITNESS ARE EXCLUDED. SOME STATES DO NOT ALLOW LIMITATIONS ON HOW LONG THE IMPLIED WARRANTY LASTS, SO THE ABOVE LIMITATION MAY NOT APPLY TO YOU.

WMH TOOL GROUP SHALL IN NO EVENT BE LIABLE FOR DEATH, INJURIES TO PERSONS OR PROPERTY, OR FOR INCIDENTAL, CONTINGENT, SPECIAL, OR CONSEQUENTIAL DAMAGES ARISING FROM THE USE OF OUR PRODUCTS. SOME STATES DO NOT ALLOW THE EXCLUSION OR LIMITATION OF INCIDENTAL OR CONSEQUENTIAL DAMAGES, SO THE ABOVE LIMITATION OR EXCLUSION MAY NOT APPLY TO YOU.

WMH Tool Group sells through distributors only. The specifications in WMH catalogs are given as general information and are not binding. Members of WMH Tool Group reserve the right to effect at any time, without prior notice, those alterations to parts, fittings, and accessory equipment which they may deem necessary for any reason whatsoever.

Table of Contents

Warranty and Service	2
Table of Contents	3
Warning.....	4
Introduction	6
Description	6
Specifications	6
Features.....	7
Unpacking	8
Contents of Shipping Containers	8
Assembly	9
Grounding Instructions.....	11
Extension Cords.....	12
Adjustments	12
Swing.....	12
Raise/Lower.....	12
Forward/Back.....	12
Rotate.....	12
Pivot	13
Operating Controls	13
Switch.....	13
Speed Selection.....	13
Operation	13
General Operating Instructions.....	14
Spacers	14
Rollers	15
Drive Belt Replacement.....	15
Lubrication	15
Troubleshooting.....	17
Replacement Parts	18
Parts List: Stand Assembly.....	19
Stand Assembly	21
Parts List: PF3-EZ Feeder.....	22
PF3-EZ Feeder	24
Electrical Connections	25
Boring Template	27



Warnings

1. Read and understand the entire owners manual before attempting assembly or operation.
2. Read and understand the warnings posted on the machine and in this manual. Failure to comply with all of these warnings may cause serious injury.
3. Replace the warning labels if they become obscured or removed.
4. This stock feeder is designed and intended for use by properly trained and experienced personnel only. If you are not familiar with the proper and safe operation of a stock feeder, do not use until proper training and knowledge have been obtained.
5. Do not use this stock feeder for other than its intended use. If used for other purposes, WMH Tool Group disclaims any real or implied warranty and holds itself harmless from any injury that may result from that use.
6. Always wear approved safety glasses/face shield while using this stock feeder. Everyday eyeglasses only have impact resistant lenses; they are not safety glasses.
7. Before operating this stock feeder, remove tie, rings, watches and other jewelry, and roll sleeves up past the elbows. Remove all loose clothing and confine long hair. Non-slip footwear or anti-skid floor strips are recommended. Do **not** wear gloves.
8. Wear ear protectors (plugs or muffs) during extended periods of operation.
9. Some dust created by power sanding, sawing, grinding, drilling and other construction activities contain chemicals known to cause cancer, birth defects or other reproductive harm. Some examples of these chemicals are:
 - Lead from lead based paint.
 - Crystalline silica from bricks, cement and other masonry products.
 - Arsenic and chromium from chemically treated lumber.Your risk of exposure varies, depending on how often you do this type of work. To reduce your exposure to these chemicals, work in a well-ventilated area and work with approved safety equipment, such as face or dust masks that are specifically designed to filter out microscopic particles.
10. Do not operate this machine while tired or under the influence of drugs, alcohol or any medication.
11. Make certain the switch is in the **OFF** position before connecting the machine to the power supply.
12. Make certain the machine is properly grounded.
13. Make all machine adjustments or maintenance with the machine unplugged from the power source.
14. Remove adjusting keys and wrenches. Form a habit of checking to see that keys and adjusting wrenches are removed from the machine before turning it on.
15. Keep safety guards in place at all times when the machine is in use. If removed for maintenance purposes, use extreme caution and replace the guards immediately.
16. Make sure the stock feeder is firmly secured to the table saw before use.
17. Check damaged parts. Before further use of the machine, a guard or other part that is damaged should be carefully checked to determine that it will operate properly and perform its intended function. Check for alignment of moving parts, binding of moving parts, breakage of parts, mounting and any other conditions that may affect its operation. A guard or other part that is damaged should be properly repaired or replaced.
18. Provide for adequate space surrounding work area and non-glare, overhead lighting.
19. Keep the floor around the machine clean and free of scrap material, oil and grease.
20. Keep visitors a safe distance from the work area. **Keep children away.**



Warnings

21. Make your workshop child proof with padlocks, master switches or by removing starter keys.
22. Give your work undivided attention. Looking around, carrying on a conversation and “horse-play” are careless acts that can result in serious injury.
23. Maintain a balanced stance at all times so that you do not fall or lean against moving parts. Do not overreach or use excessive force to perform any machine operation.
24. Use the right tool at the correct speed and feed rate. Do not force a tool or attachment to do a job for which it was not designed. The right tool will do the job better and safer.
25. Use recommended accessories; improper accessories may be hazardous.
26. Maintain tools with care. Keep tools sharp and clean for the best and safest performance. Follow instructions for lubricating and changing accessories.
27. Turn off the stock feeder and the table saw before cleaning. Use a brush or compressed air to remove chips or debris — do not use your hands.
28. Do not stand on the machine. Serious injury could occur if the machine tips over.
29. Never leave the machine running unattended. Turn the power off and do not leave the machine until it comes to a complete stop.
30. Remove loose items and unnecessary work pieces from the area before starting the machine.

Familiarize yourself with the following safety notices used in this manual:

CAUTION

This means that if precautions are not heeded, it may result in minor injury and/or possible machine damage.

WARNING

This means that if precautions are not heeded, it may result in serious injury or possibly even death.

- - SAVE THESE INSTRUCTIONS - -

Introduction

This manual is provided by WMH Tool Group, Inc. covering the safe operation and maintenance procedures for a Model PF3-EZ Stock Feeder. This manual contains instructions on installation, safety precautions, general operating procedures, maintenance instructions and parts breakdown. This machine has been designed and constructed to provide years of trouble free operation if used in accordance with instructions set forth in this manual. If there are any questions or comments, please contact either your local supplier or WMH Tool Group. WMH Tool Group can also be reached at our web site: www.wmhtoolgroup.com.

Description

The PF3-EZ Stock Feeder can be mounted to a table saw to safely and effectively feed workpieces into the blade. The Stock Feeder has a continuous duty motor and lubricated gearbox that transmit power through roller chain and sprockets to the feed rollers, providing superior positive feeding for all types of materials. Heavy-duty locking mechanisms secure the feeder in position. The roller system is “maintenance-friendly” allowing you to replace a single roller if necessary, instead of a complete set.

Specifications

Model number	PF3-EZ
Stock number (230V).....	1790814K
Stock number (460V).....	1790815K
Motor.....	TEFC, 3/4HP, 3Ph
Height with handle (in.).....	31.5
Width (in.).....	21.85
Length with handle and arm fully extended (in.)	51.5
Elevating Column diameter (in.).....	2
Horizontal Arm diameter (in.)	2.3
Rollers (dia. x w) (in.).....	4-3/4 x 1, polyurethane
Rotation.....	forward/reverse
Number of speeds	variable
Range of speeds (FPM).....	6.5 to 66
Distance between rollers, center-to-center (in.)	5.93 to 5.31
Swing (deg.).....	360
Vertical movement (in.).....	8.33
Horizontal movement (in.).....	29.33
Maximum height of rollers parallel to table top (in.).....	7.47
Approximate shipping weight (lbs.)	180
Approximate net weight (lbs.).....	170

The above specifications were current at the time this manual was published, but because of our policy of continuous improvement, WMH Tool Group reserves the right to change specifications at any time and without prior notice, without incurring obligations.

Features

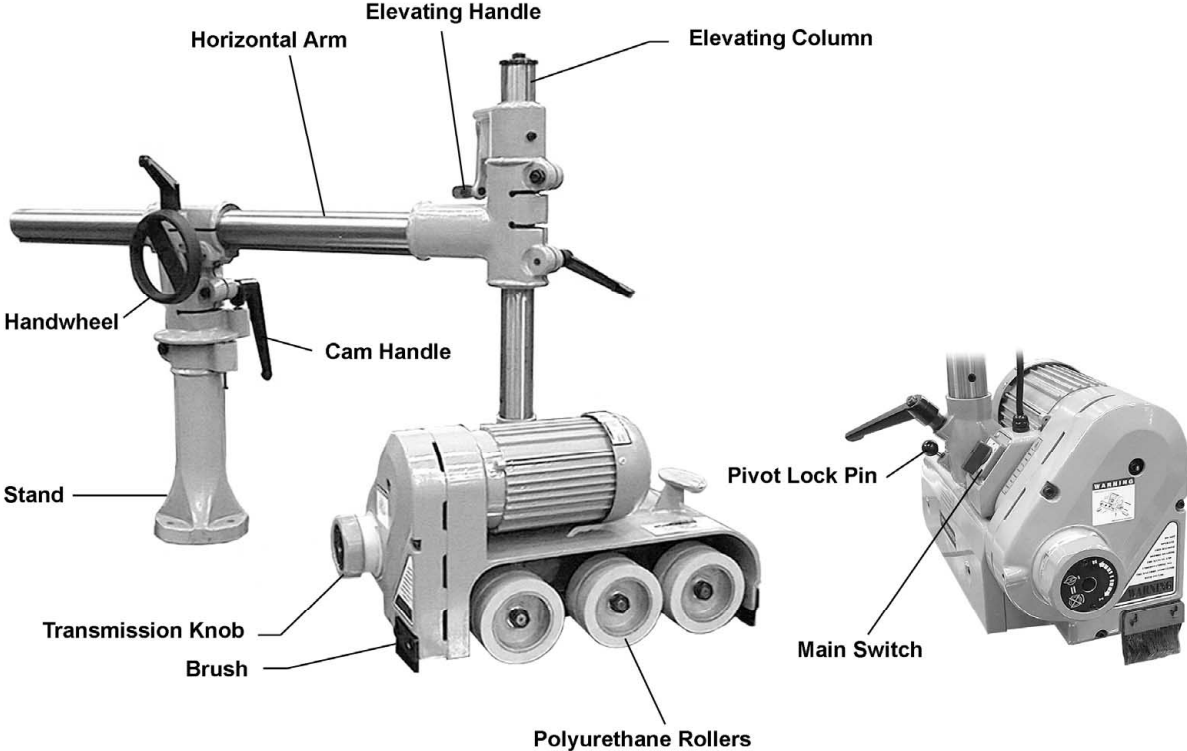

Unpacking

Open shipping containers and check for shipping damage. Report any damage immediately to your distributor and shipping agent. Do not discard any shipping material until the Stock Feeder is mounted and running properly.

Compare the contents of the containers with the following parts list to make sure all parts are intact. Missing parts, if any, should be reported to your distributor. Read the instruction manual thoroughly for assembly, maintenance and safety instructions.

Contents of Shipping Containers

Box 1:

- 1 Stock Feeder
- 1 Grease Gun (grease not included)

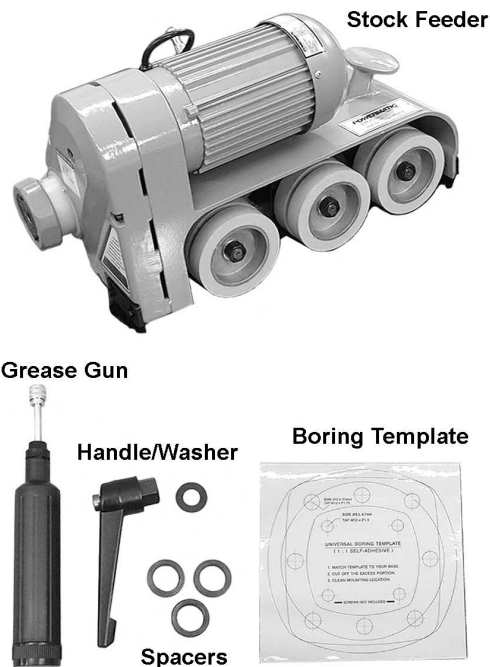

BOX 1

- 1 Handle with Flat Washer
- 3 Spacers
- 1 Boring Template
- 1 Owner's Manual
- 1 Warranty Card

Box 2:

- 1 Elevating Column
- 1 Stand
- 1 Handwheel
- 1 Cast Iron Cam Handle
- 1 Pin Assembly
- 1 Cast Iron Handle with Flat Washer
- 1 Handle with Flat Washer

Box 3:

- 1 Horizontal Arm

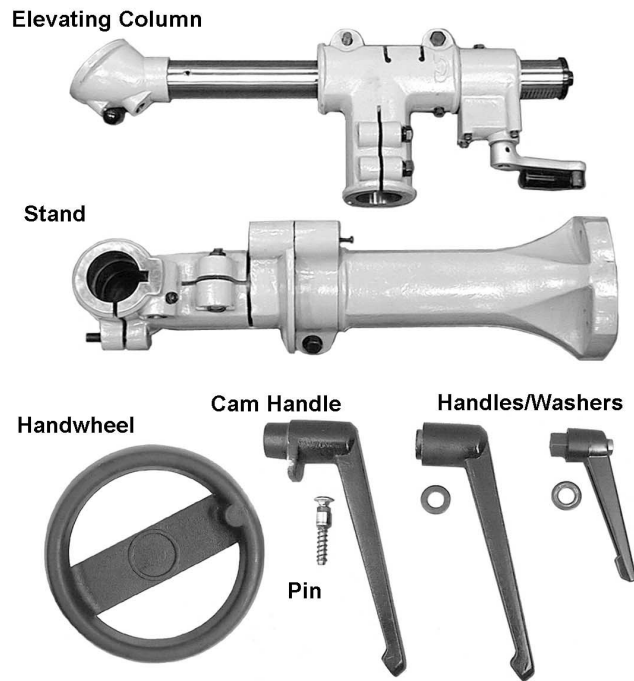

BOX 2

Horizontal Arm



BOX 3

WARNING

Read and understand the entire contents of this manual before attempting set-up or operation! Failure to comply may cause serious injury.

Assembly

Tools needed for assembly (not provided):

Electric drill
center punch and hammer
10.5mm drill bit
M12 x P1.75 tap
12mm and 19mm wrenches
4mm hex wrench

Hardware needed for assembly (not provided):

4 M12 flat washers
4 M12 x P1.75 hex cap screws (length will depend upon thickness of saw table)

Exposed metal areas of the Stock Feeder have been factory coated with a protectant. This should be removed with a soft cloth dampened with kerosene or mineral spirits. Do not use gasoline, acetone or lacquer thinner for this purpose. Do not get solvents near plastic or rubber parts, and do not use an abrasive pad because it may scratch metal surfaces.

The Stock Feeder should be mounted securely to a table saw in a well-lit area. Leave enough space around the work area for loading and off-loading stock and general maintenance.

⚠WARNING The stock feeder and the table saw to which you are mounting it should both be disconnected from power during installation.

1. Determine the mounting location for the stand. Keep in mind the overall length of the horizontal arm, so that after it is mounted to the stand it will have enough adjustment for positioning the Stock Feeder.
2. Use the provided boring template to find the centerline spacing for the holes in the base of the stand. Clean the table surface, then remove the backing from the boring template and carefully stick the boring template into place on the mounting surface. (NOTE: This template is also on page 27.)
3. Center punch and drill four 10.5 mm diameter holes in the surface, then tap the holes with M12 x P1.75 threads.
4. Peel off the boring template and discard.
5. Place the stand in position, align the four holes in the stand with the holes in the table, and insert four M12 hex cap screws with four M12 flat washers (not provided). See Figure 1.

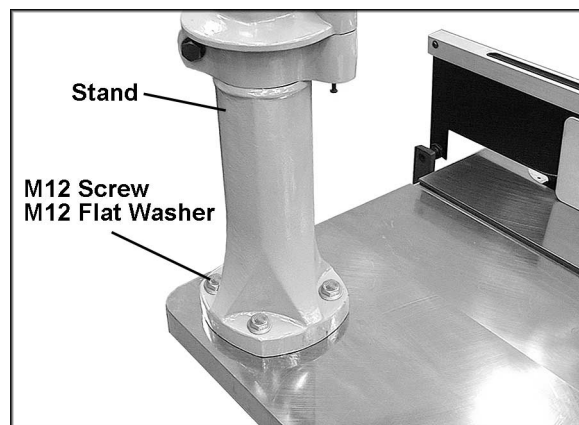

Figure 1

6. Tighten the screws firmly with a 19mm wrench.
7. Insert the pin assembly into the hole (Figure 2). You may need to rotate it until it seats properly in the hole.

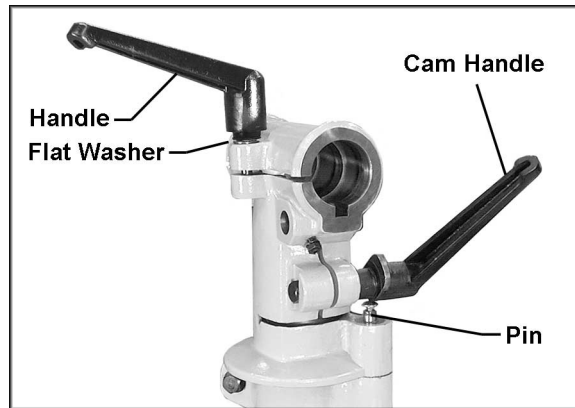

Figure 2

8. Install a flat washer and cast iron handle (Figure 2) to the threads of the top screw as shown, by screwing the handle down clockwise onto the screw threads.
9. In the area above the pin, remove the hex nut from the screw with a 19mm wrench, but leave the flat washer in place. In place of the hex nut, install the cam handle (Figure 2). Screw the cam handle clockwise onto the threads (the cam handle will contact the pin on each rotation and push the pin downward.) Tighten the cam handle.

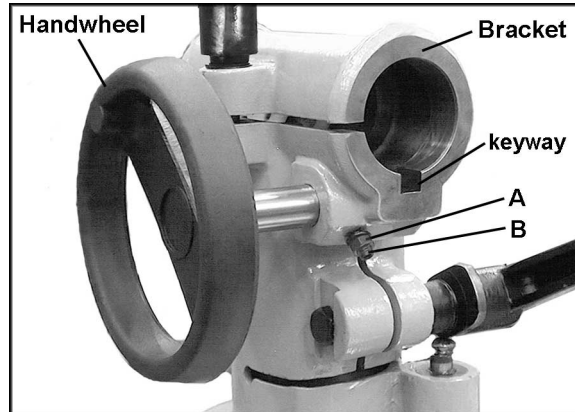

Figure 3

10. Loosen the hex nut (A, Figure 3) with a 12mm wrench, and back off the set screw (B, Figure 3) with a 4mm hex wrench, until the shaft of the handwheel can be inserted freely into the hole in the bracket (Figure 3). The handwheel should be positioned so that the pinion on its shaft is approximately centered with the keyway of the bracket.
11. Turn the set screw (B, Figure 3) clockwise into the shaft just enough to prevent the handwheel from slipping out. Do not overtighten the set screw. Tighten the hex nut (A, Figure 3).

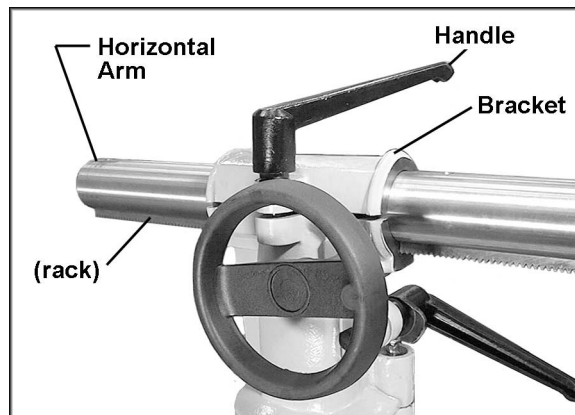

Figure 4

12. Loosen the handle above the bracket (Figure 4).
13. The end of the horizontal arm that has the rack extending to the end will be inserted into the bracket. Insert the horizontal arm, with the rack pointed downward, into the bracket. The rack will fit through the keyway in the bracket. See Figure 4. Continue to push the horizontal arm into the bracket while slightly rotating the handwheel counterclockwise, until the rack and pinion mesh. The horizontal arm can now be moved into the bracket by rotating the handwheel.

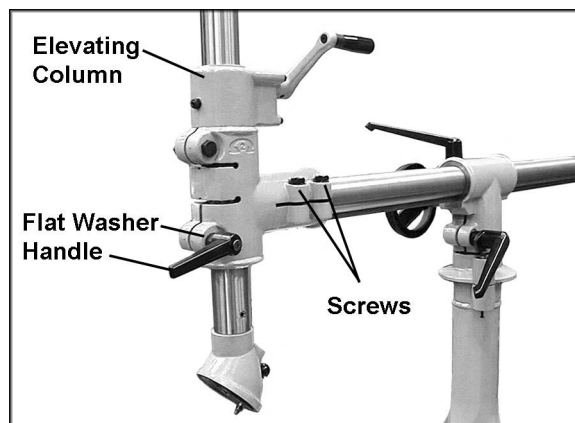

Figure 5

14. Install the elevating column onto the horizontal arm (Figure 5). Make sure the horizontal arm slides all the way into the sleeve of the elevating column (The end of the rack on the horizontal arm will almost touch the sleeve). Check that the elevating column assembly is in the vertical position. Tighten the two screws on the sleeve (Figure 5) with a 19mm wrench.
15. Install a flat washer and handle on the screw of the elevating column (Figure 5).

NOTE: The handle can be pivoted out of the way if necessary. Lift up on the handle, rotate the handle on its pin, then release the handle, making sure it fully seats itself on the pin.

16. Mount the stock feeder to the elevating column by sliding the stud of the stock feeder into the hole of the pivot joint (Figure 6). Install the remaining flat washer and handle onto the stud, and tighten the handle.

Grounding Instructions

⚠WARNING Electrical connections must be made by a qualified electrician in compliance with all relevant codes. This machine must be properly grounded to help prevent electrical shock and possible fatal injury.

As received from the factory, the PF3-EZ Stock Feeder will run on either 230 volt or 460 volt, depending upon your particular model. Make sure the voltage of your power supply matches the specifications on the motor plate of the Stock Feeder.

You may either connect an appropriate UL/CSA listed plug or “hard-wire” the machine directly to a control panel. If hard-wired to a panel, make sure a disconnect is available for the operator. The Stock Feeder must comply with all local and national codes after being wired. If it is to be hard-wired, make sure the fuses have been removed or the breakers have been tripped in the circuit to which the Stock Feeder will be connected. Place a warning placard on the fuse holder or circuit breaker to prevent it being turned on while the machine is being wired.

Refer to “Electrical Connections” on page 25 for connecting the motor leads.

This machine must be grounded. In the event of a malfunction or breakdown, grounding provides a path of least resistance for electric current, to reduce the risk of electric shock to the operator. Improper connection of the equipment-grounding conductor can result in a risk of electric shock. The conductor, with insulation having an outer surface that is green with or without yellow stripes, is the equipment-grounding conductor. If repair or replacement of the electric cord or plug is necessary, do not connect the equipment-grounding conductor to a live terminal.

Repair or replace a damaged or worn cord immediately.

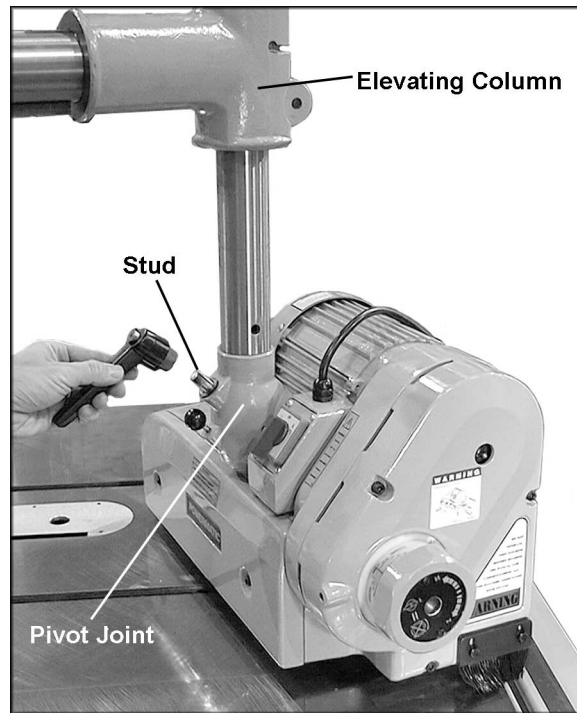

Figure 6

Extension Cords

If an extension cord is necessary make sure the cord rating is suitable for the amperage listed on the machine's motor plate. An undersize cord will cause a drop in line voltage resulting in loss of power and overheating.

The chart in Figure 7 shows the correct size cord to use based on cord length and motor plate amp rating. If in doubt, use the next heavier gauge. The smaller the gauge number the heavier the cord.

Recommended Gauges (AWG) of Extension Cords

Amps	Extension Cord Length *					
	25 feet	50 feet	75 feet	100 feet	150 feet	200 feet
< 5	16	16	16	14	12	12
5 to 8	16	16	14	12	10	NR
8 to 12	14	14	12	10	NR	NR
12 to 15	12	12	10	10	NR	NR
15 to 20	10	10	10	NR	NR	NR
21 to 30	10	NR	NR	NR	NR	NR

*based on limiting the line voltage drop to 5V at 150% of the rated amperes.

NR: Not Recommended.

Adjustments

Swing

To swing the Stock Feeder laterally, loosen the cam handle counterclockwise so that it pushes down the pin, as shown in Figure 8. Swing the horizontal arm and feeder into desired position (the top part of the stand will rotate). When the Stock Feeder is properly positioned, tighten cam handle.

To rotate the top of the stand back to original position, loosen the cam handle and rotate the top section of the stand, allowing the pin to snap back into the hole. Tighten the cam handle.

Figure 7

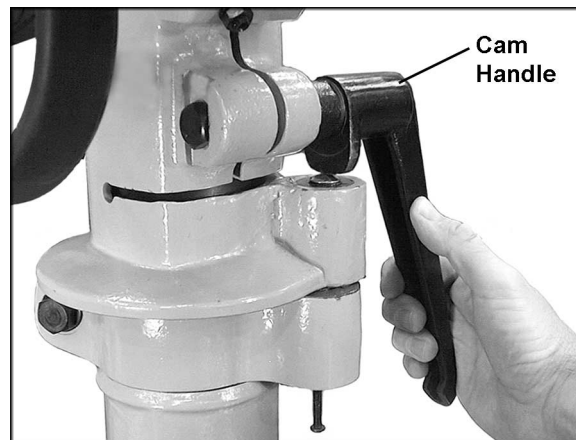

Figure 8

Raise/Lower

To raise or lower the Stock Feeder, loosen the handle (A, Figure 9) and rotate the elevating handle (B, Figure 9). When finished, tighten the handle (A, Figure 9).

Forward/Back

To move the horizontal arm forward or back, loosen the handle (C, Figure 9) and rotate the handwheel (D, Figure 9). When finished, tighten the handle (C, Figure 9).

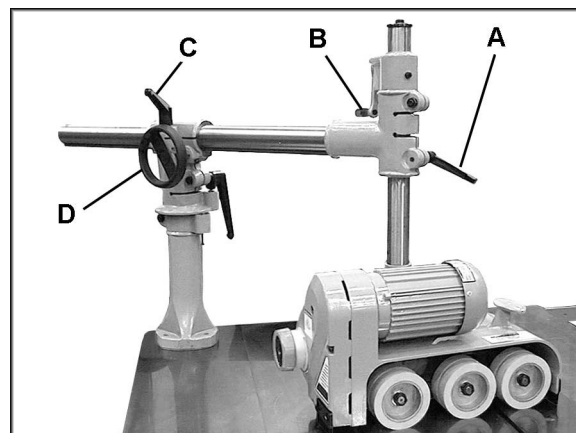

Figure 9

Rotate

To rotate the Stock Feeder (up to 360 degrees), loosen the handle on the vertical arm (A, Figure 9). When finished rotating the Stock Feeder, tighten the handle (A, Figure 9).

Pivot

To pivot the Stock Feeder (for maintenance, oil filling, etc.):

1. Loosen the handle (E, Figure 10) and pull up on the pin (F, Figure 10).
2. Pivot the Stock Feeder into position. (NOTE: At 90 degrees of pivot, as shown in Figure 10, the pin will lock into place.)
3. Re-tighten the handle (E, Figure 10).

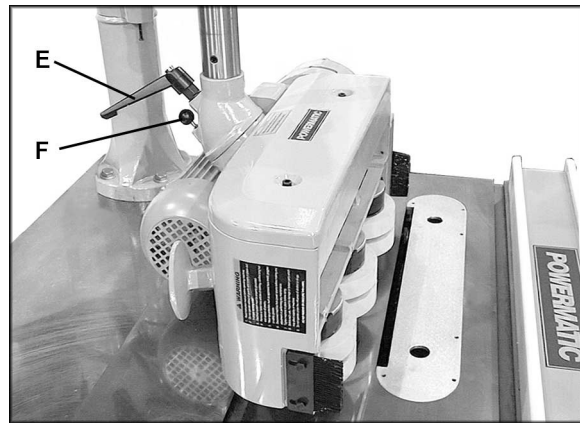

Figure 10

Operating Controls

Switch

The control switch is shown in Figure 11. The switch can be set to either Forward or Reverse (the arrows on the switch label reflect the direction of roller rotation).

⚠ WARNING Never put the stock feeder into reverse while the table saw blade is still rotating. Failure to comply may cause stock kickback and personal injury.

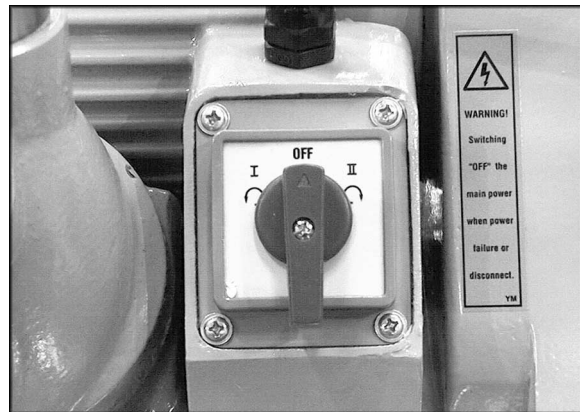

Figure 11

Speed Selection

The speed, or feed rate of the Stock Feeder is variable, ranging from 6.5 to 66 feet per minute. The speed is adjusted by setting the control switch (Figure 11) and rotating the transmission knob, shown in Figure 12. Rotating the transmission knob clockwise decreases the speed, counterclockwise increases it.

The speed is established when the edge of the transmission knob lines up with the appropriate line on the speed scale. See Figure 12. The speed scale is graduated in feet per minute, and meters per minute.

The transmission knob should only be adjusted when the Stock Feeder is operating; that is, when the control switch is in either forward or reverse.

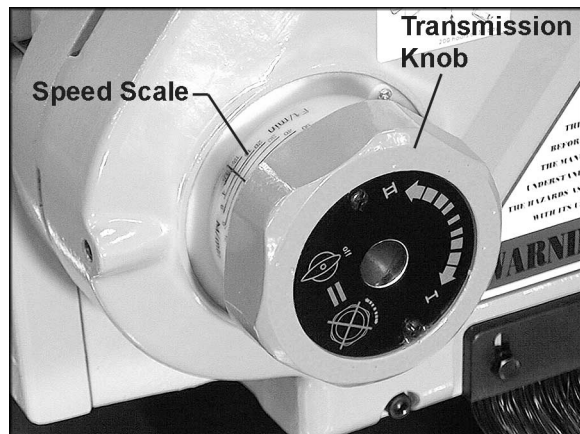

Figure 12

Operation

IMPORTANT: Before operating the Stock Feeder, you should be thoroughly familiar with the safety and operating instructions that accompanied your table saw.

⚠ WARNING Keep hands away from rollers and blade area during operation. Failure to comply may cause injury.

General Operating Instructions

1. Make sure all locking handles are tight before operating the Stock Feeder.
2. The Stock Feeder should be used in conjunction with a fence on the table saw.
3. The rollers must grip the offcut as well as the part of the workpiece being fed.
4. Position the Stock Feeder so that the axis of the saw blade lines up between the infeed roller and center roller. See Figure 13. This will allow the Stock Feeder to grip the near part of the workpiece as it enters the blade, as well as the offcut of the workpiece as it leaves the blade.
5. Rotate the Stock Feeder so that the direction of feed is angled slightly toward the fence by approximately $3/16"$ (5mm); that is, the outfeed roller should be slightly closer to the fence than the infeed roller. See Figure 13.

IMPORTANT: Do not position the stock feeder in such a way that the rollers will interfere with, or be damaged by, the blade.

6. The Stock Feeder should be adjusted for height so that the distance between the table and the feed rollers is approximately $1/8"$ (3mm) less than the thickness of the workpiece. See Figure 14.
7. The feed rollers have a spring suspension, which will exert the necessary pressure against the workpiece. This pressure increases automatically with feed resistance, so that a workpiece of varying thickness can be fed through the Stock Feeder without adjustments.
8. If a workpiece becomes jammed during cutting operation, shut off the table saw and the Stock Feeder. Then raise the Stock Feeder, remove workpiece, re-position the Stock Feeder and begin the cutting operation again.
9. Using hardwood with the Stock Feeder may increase the friction between workpiece and saw table. Keep the saw table rust-free and smooth by using paste wax or other necessary means.

Spacers

Three spacers are included with the Stock Feeder. These are used to increase the kerf spacing between inner and outer rollers. See Figure 15.

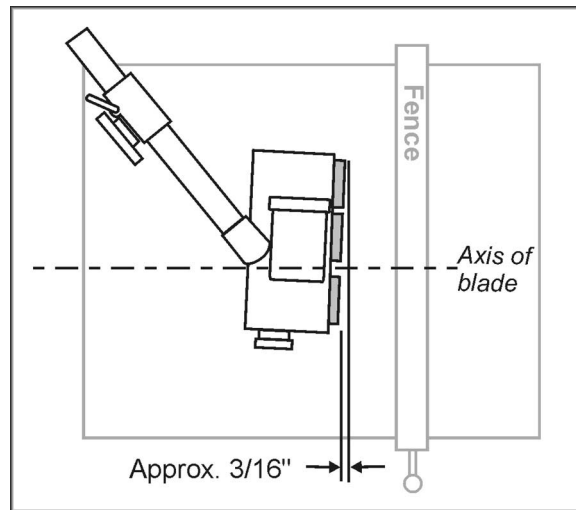

Figure 13
(guard removed for clarity)

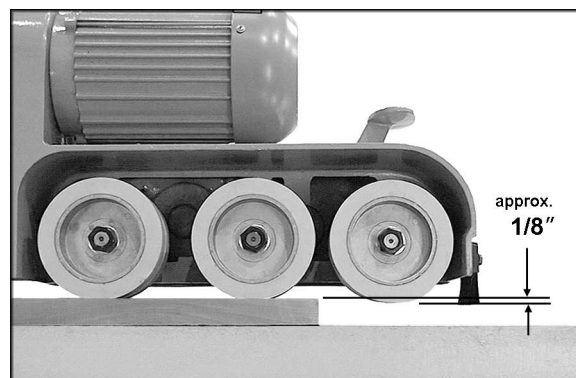

Figure 14



Figure 15

1. Loosen and remove the hex nut and flat washer on the roller shaft with a 24mm wrench.
2. Remove the outer roller.
3. Install a spacer on the shaft and flush against the inner roller as shown in Figure 15.
4. Re-install the outer roller.
5. Install the flat washer and hex nut and tighten with wrench.
6. Repeat for the other rollers if needed.

Maintenance

⚠WARNING Before performing any maintenance on the Stock Feeder, disconnect it from the electrical supply by pulling out the plug or switching off the breaker. Also make sure the table saw is disconnected from power.

If the power cord is worn, cut, or damaged in any way, have it replaced immediately.

Rollers

The polyurethane rollers should be kept clean of grease, sawdust and other debris. Use a soft cloth with soap and water to wipe down the rollers. DO NOT use a solvent on the rollers.

The rollers can be removed from the Stock Feeder for replacement or maintenance purposes. To remove a roller, loosen and remove the hex nut and flat washer (Figure 15) with a 24mm wrench and pull the roller(s) off the shaft.

Drive Belt Replacement

1. Remove the guard cover (Figure 16) by loosening and removing the three socket head cap screws with a 5mm hex wrench.
2. Remove the old belt from around the pulley and install the new belt.
3. Re-install the guard cover, making sure the keyway on the shaft pulley aligns with the key on the shaft.

Lubrication

Every 200 hours, or 30 days, insert grease into the two grease fittings on the end of the Stock Feeder (Figure 17), and the grease fittings on the tip of each sprocket shaft located inside the housing (Figure 18).

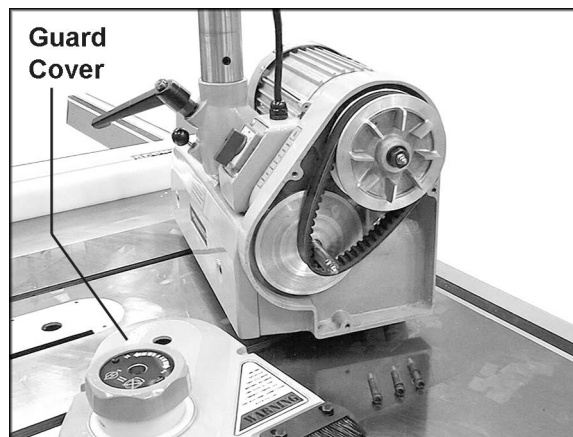

Figure 16

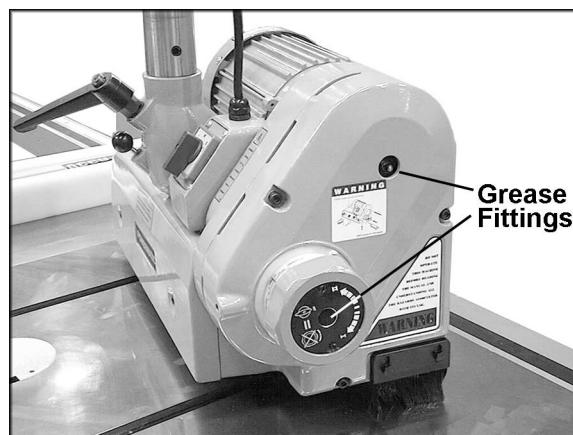

Figure 17

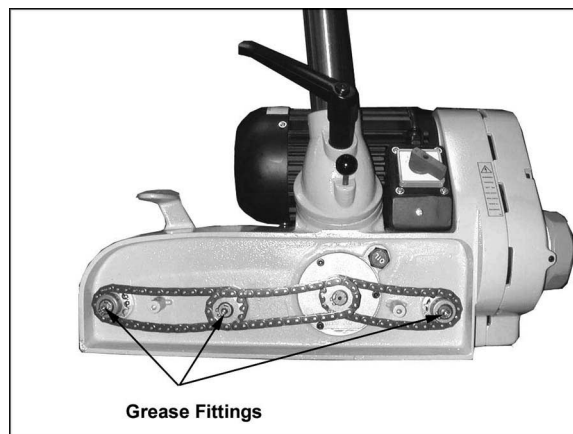

Figure 18

Fill the oil reservoir about every 1,000 hours or six months, or sooner if needed. To fill with oil:

1. Pivot the Stock Feeder so that the rollers are facing down. See Figure 19.
2. Unscrew and remove the two socket head cap screws on the back cover with a 5mm hex wrench, and remove the back cover (Figure 19).
3. Unscrew the oil cap (Figure 19) and pour a good quality general purpose oil into the hole. Do not overfill.
4. When finished, install and tighten the oil cap, and install the back cover.

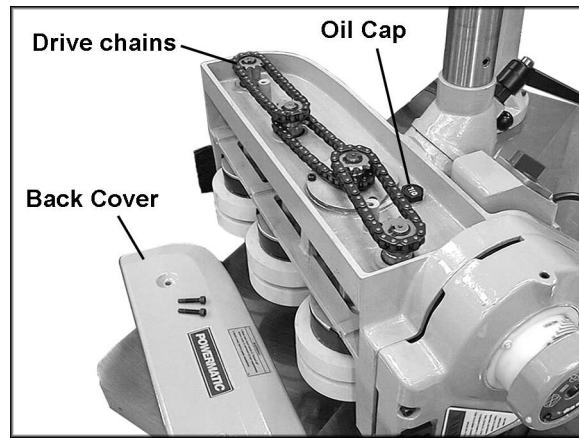

Figure 19

Lubricate the drive chains (Figure 19) with good quality all-purpose grease every 3 months, or more frequently if needed.

The exposed metal of the horizontal arm and elevating column should be kept clean and free of rust. Occasionally wipe them down with a soft cloth and apply a light coat of oil to these areas.

Apply a light amount of grease to the rack on the horizontal arm.

Troubleshooting

Trouble	Probable Cause	Remedy
Feeder will not start.	Not connected to power source.	Check plug connection.
	Fuse blown, or circuit breaker tripped.	Replace fuse, or reset circuit breaker.
	Cord damaged.	Replace cord.
Feed speed is not sufficient; machine has low power.	Extension cord too light or too long.	Replace with adequate size and length cord. [page 12]
	Low current from electrical supply.	Contact a qualified electrician.
Workpiece jams while feeding it beneath rollers.	Rollers too low.	Raise feeder.
Workpiece slips while passing under rollers.	Rollers too high, no traction.	Lower feeder.
	Grease or debris on rollers.	Clean rollers.

Replacement Parts

Replacement parts are listed on the following pages. To order parts or reach our service department, call 1-800-274-6848, Monday through Friday (see our website for business hours, www.powermatic.com). Having the Model Number and Serial Number of your machine available when you call will allow us to serve you quickly and accurately.

Parts List: Stand Assembly

Index No.	Part No.	Description	Size	Qty
1	PF3EZ-101	Column Base		1
2	PF3EZ-102	Memo-Lock Collar		1
3	TS-2360121	Flat Washer	M12	1
4	TS-1492051	Hex Cap Screw	M12x50	1
5	PF3EZ-105	Memo-Lock Tube		1
6	PF3EZ-106	Memo-Lock Support		1
7	PF3EZ-107	Spring		1
8	TS-2285502	Machine Screw, Pan Head	M5x50	1
9	PF3EZ-109	Extension Bracket		1
10	PF3EZ-110	Memo-Handle		1
11	TS-2360121	Flat Washer	M12	1
12	TS-2211651	Hex Cap Screw	M12x65	1
13	PF3EZ-113	Handle		1
14	PF3EZ-114	Stud		1
15	TS-0680061	Flat Washer	1/2"	1
16	PF3EZ-116	Pinion		1
17	TS-1524061	Socket Set Screw	M8X25	1
18	TS-2361081	Lock Washer	M8	1
19	TS-1540061	Hex Nut	M8	1
20	PF3EZ-120	Carriage Bolt	M6x25	1
21	TS-1540041	Hex Nut	M6	1
22	PF3EZ-122	Lock Pin		1
23	PF3EZ-123	Spring		1
24	PF3EZ-124	Elevating Bracket		1
25	TS-1492051	Hex Cap Screw	M12x50	2
26	TS-2361121	Lock Washer	M12	2
27	TS-1524061	Socket Set Screw	M8x25	1
28	TS-2361081	Lock Washer	M8	1
29	TS-1540061	Hex Nut	M8	1
30	TS-2211651	Hex Cap Screw	M12x65	1
31	TS-2361121	Lock Washer	M12	1
32	TS-1540081	Hex Nut	M12	1
33	PF3EZ-133	Handle		1
34	TS-0680061	Flat Washer	1/2"	1
35	PF3EZ-135	Stud		1
36	PF3EZ-136	Elevating Column		1
37	PF3EZ-137	Column Cap		1
38	PF3EZ-138	Elevating Support		1
39	TS-1524061	Socket Set Screw	M8x25	1
40	TS-2361081	Lock Washer	M8	1
41	TS-1540061	Hex Nut	M8	1
42	PF3EZ-142	Bevel Gear		1
43	PF3EZ-143	Spacer		2
44	PF3EZ-144	Shaft		1
45	PF3EZ-145	Elevating Support Cover		1
46	PF3EZ-146	Thrust Bushing		1
47	TS-1551041	Lock Washer	M6	4
48	TS-1503051	Socket Head Cap Screw	M6x20	4
49	PF3EZ-149	Elevating Screw		1
50	PF3EZ-150	Elevating Handle		1
51	PF3EZ-151	Lock Pin	6x30	1
52	PF3EZ-152	Pivot Joint		1
53	PF3EZ-153	Lock Pin		1
54	PF3EZ-154	Pivot Lock Pin		1
55	PF3EZ-155	Spring		1
56	PF3EZ-156	Knob		1
57	PF3EZ-157	Horizontal Arm		1

Index No.	Part No.	Description	Size	Qty
58.....	PF3EZ-158	Rack		1
59.....	TS-1502021	Socket Head Cap Screw.....	M5x10	5
60.....	PF3EZ-160	Hand Wheel		1
61.....	PF3EZ-161	Lock Pin	6x36.....	1

Stand Assembly

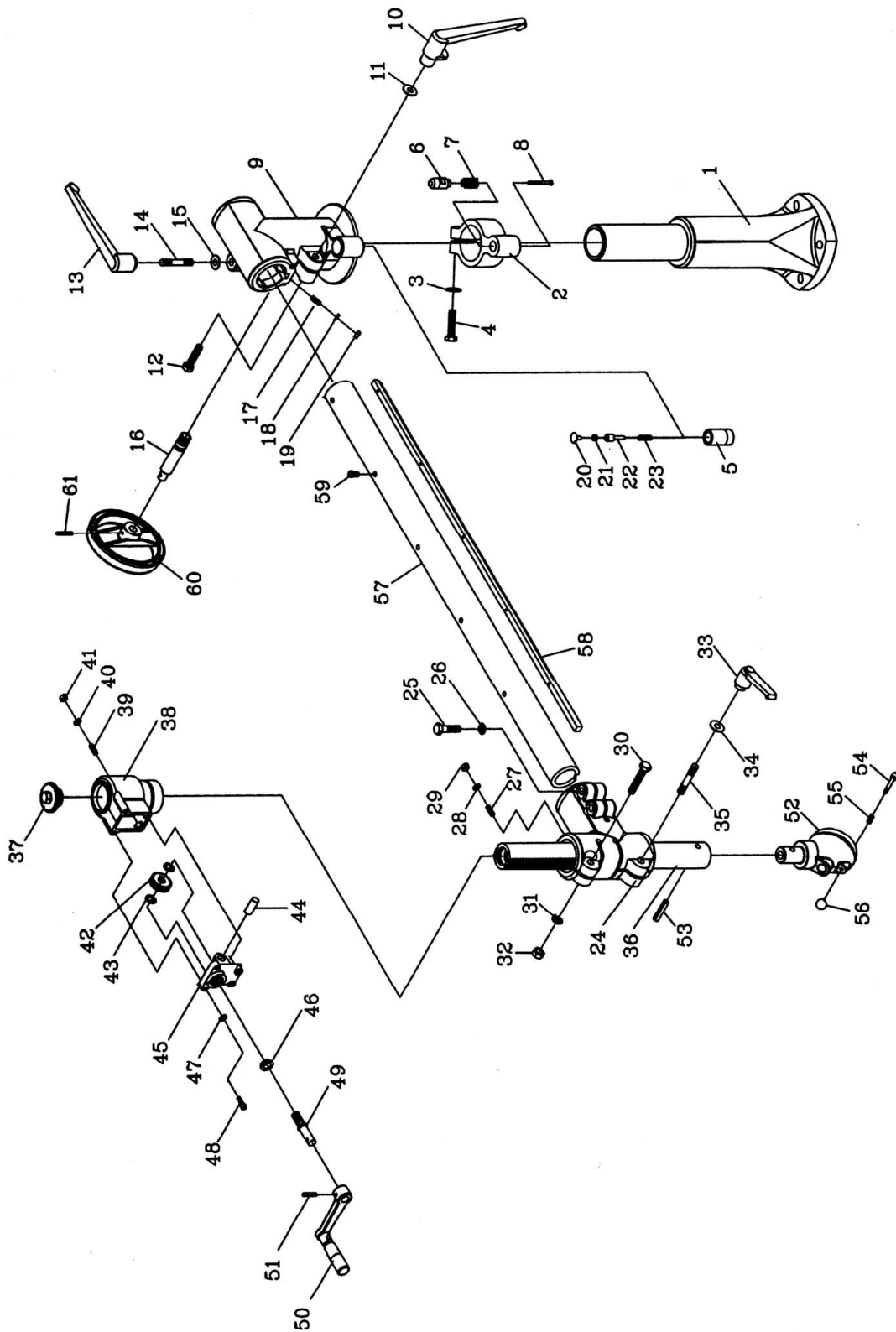

Parts List: PF3-EZ Feeder

Index No.	Part No.	Description	Size	Qty
1	BB-6003	Bearing (#6003)	6003	1
2	BB-6004	Bearing (#6004)	6004	1
3	BB-6006ZZ	Bearing (#6006ZZ)	6006ZZ	1
4	PF3EZ-204	Chain (26S)	26S	3
6	6288938A	Tube		3
7	PF3EZ-207	Snap Ring	26#	3
8	6289125A	Sprocket Shaft		3
9	PF3EZ-209	Snap Ring	15#	3
10	PF3EZ-210	Frame		1
11	PF3EZ-211	Bushing		1
12	PF3EZ-212	Bushing		1
13	PF3EZ-213	Bushing		2
14	TS-1523031	Socket Set Screw	M6x10	3
15	PF3EZ-215	Oil Cap		1
16	PF3EZ-216	"O" Ring		1
17	PF3EZ-217	Worm Gear Shaft		1
18	PF3EZ-218	Key	6x6x18	1
19	PF3EZ-219	Worm Gear		1
20	PF3EZ-209	Snap Ring	15#	1
21	PF3EZ-221	Worm		1
22	PF3EZ-222	Key	5x5x35	1
23	PF3EZ-223	Key	5x5x20	1
24	PF3EZ-224	Grease Fitting		1
25	PF3EZ-225	Snap Ring	20#	1
26	PF3EZ-226	Chain (36S)	36S	1
27	PF3EZ-227	Sprocket		2
28	PF3EZ-228	Chain (38S)	38S	1
29	PF3EZ-229	Sprocket		4
30	PF3EZ-230	Chain (40S)	40S	1
31	PF3EZ-231	Back Cover		1
32	TS-1503071	Socket Cap Head Screw	M6x30	2
33	PF3EZ-233	Spring Stopper		1
34	PF3EZ-234	Compression Spring		1
35	TS-2360121	Flat Washer	M12	1
36	TS-1540081	Hex Nut	M12	1
37	PF3EZ-237	Grease Fitting		4
38	PF3EZ-238	Fanned Pulley		1
39	PF3EZ-239	Motor Pulley		1
40	PF3EZ-223	Key	5x5x20	1
41	PF3EZ-222	Key	5x5x35	1
42	PF3EZ-242	Shaft Pulley		1
43	PF3EZ-243	Transmission Pulley		1
44	PF3EZ-244	Snap Ring	30#	1
45	PF3EZ-245	Belt		1
46	PF3EZ-246	Transmission Guard Cover		1
47	PF3EZ-247	Screw Thruster		1
48	PF3EZ-248	Spring		1
49	PF3EZ-249	Pointed Screw	M8x12	1
50	TS-1551041	Lock Washer	M6	3
51	TS-1503101	Socket Head Cap Screw	M6x45	3
52	PF3EZ-252	Stud		1
53	PF3EZ-253	Handle		1
54	TS-0680061	Flat Washer	1/2"	1
55	PF3EZ-255A	Sprocket Case		3
56	PF3EZ-256	Case Cap		1
57	PF3EZ-257	Spring		1

Index No.	Part No.	Description	Size	Qty
59	PF3EZ-259	Case Cap		2
60	PF3EZ-260	Spring		2
61	PF3EZ-261	Roller Spindle		3
62	TS-2360121	Flat Washer	M12	3
63	TS-1540081	Hex Nut	M12	3
64	TS-155010	Flat Washer	M16	3
65	TS-154010	Hex Nut	M16	3
66	PF3EZ-266	Sprocket		3
67	PF3EZ-267	Anti-Dust Plate		3
68	PF3EZ-268	Internal Tooth Lock Washer	M6	6
69	TS-1503051	Socket Head Cap Screw	M6x20	6
70	PF3EZ-270	Grease Gun		1
71	PF3EZ-271	Motor	3/4 HP, 230V, 3Ph	1
	PF3EZ-271A	Motor	3/4 HP, 460V, 3Ph	1
72	PF3EZ-272	Brush		2
73	PF3EZ-268	Internal Tooth Lock Washer	M6	4
74	TS-1482021	Hex Cap Screw	M6x12	4
75	PF3EZ-275	Switch Kit		1
76	PF3EZ-276	Power Cord		1
77	PF3EZ-277	Cord Socket		1
78	TS-1532032	Machine Screw, Pan Head	M4x10	2
79	PF3EZ-279	Speed Plate		1
80	PF3EZ-280	Transmission Knob		1
81	PF3EZ-281	Snap Ring	55#	1
82	PF3EZ-282	Snap Ring	65#	1
83	PF3EZ-283	"O" Ring		1
84	PF3EZ-284	Worm Gear Cover		1
85	PF3EZ-285	Oil Seal		1
86	TS-1502031	Socket Head Cap Screw	M5x12	3
87	PF3EZ-287	Oil Seal		1
88	PF3EZ-288	"O" Ring		1
89	PF3EZ-289	Worm Shaft Cap		1
90	TS-1502031	Socket Head Cap Screw	M5x12	3
91	TS-2283102	Machine Screw, Pan Head	M3x10	2
92	PF3EZ-292	Speed Indicator		1
93	PF3EZ-293	Roller (φ120x25W)		6
94	TS-1551061	Lock Washer	M8	4
95	TS-1504061	Socket Head Cap Screw	M8x30	4
96	PF3EZ-296	Spacer		3

PF3-EZ Feeder

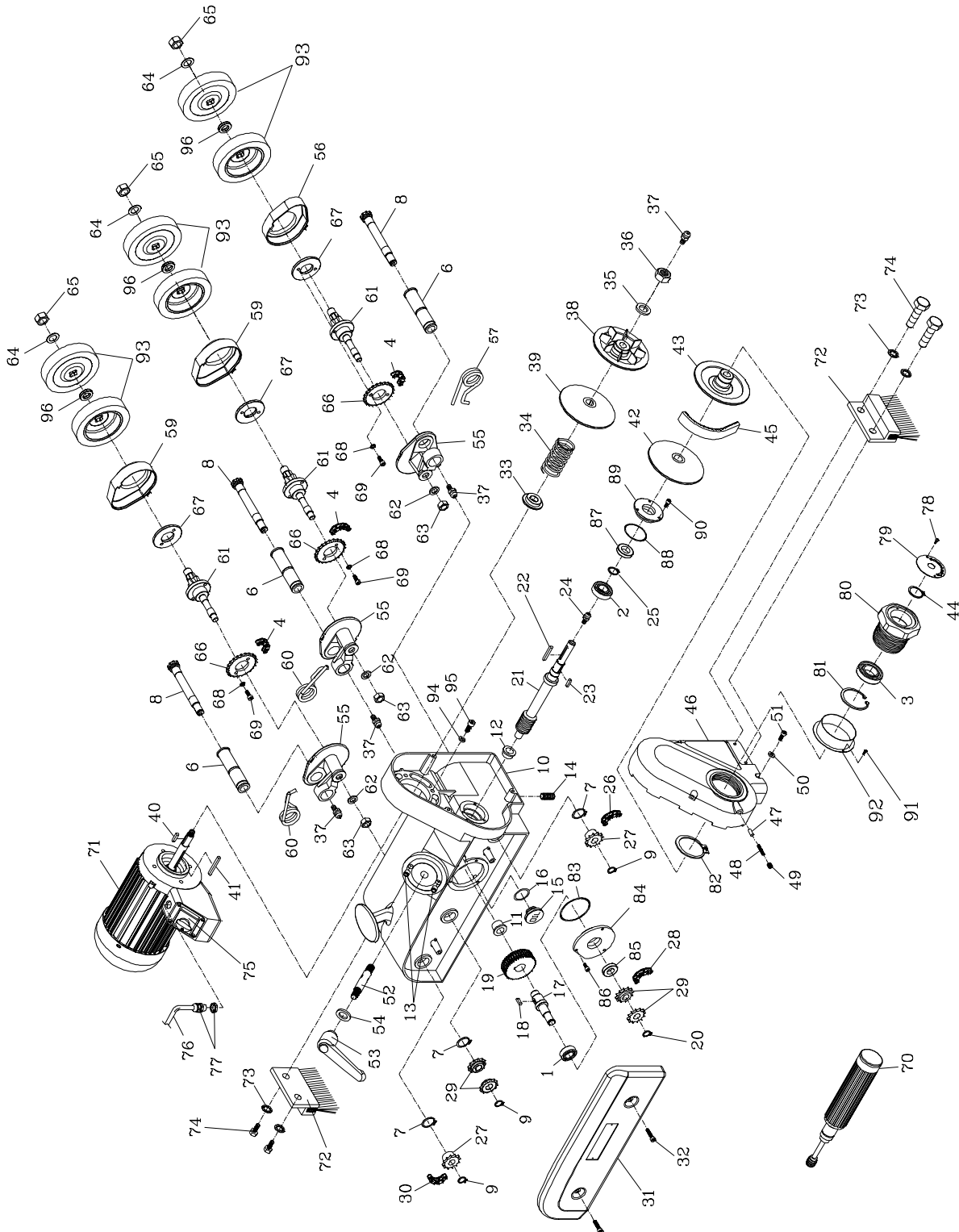

Electrical Connections

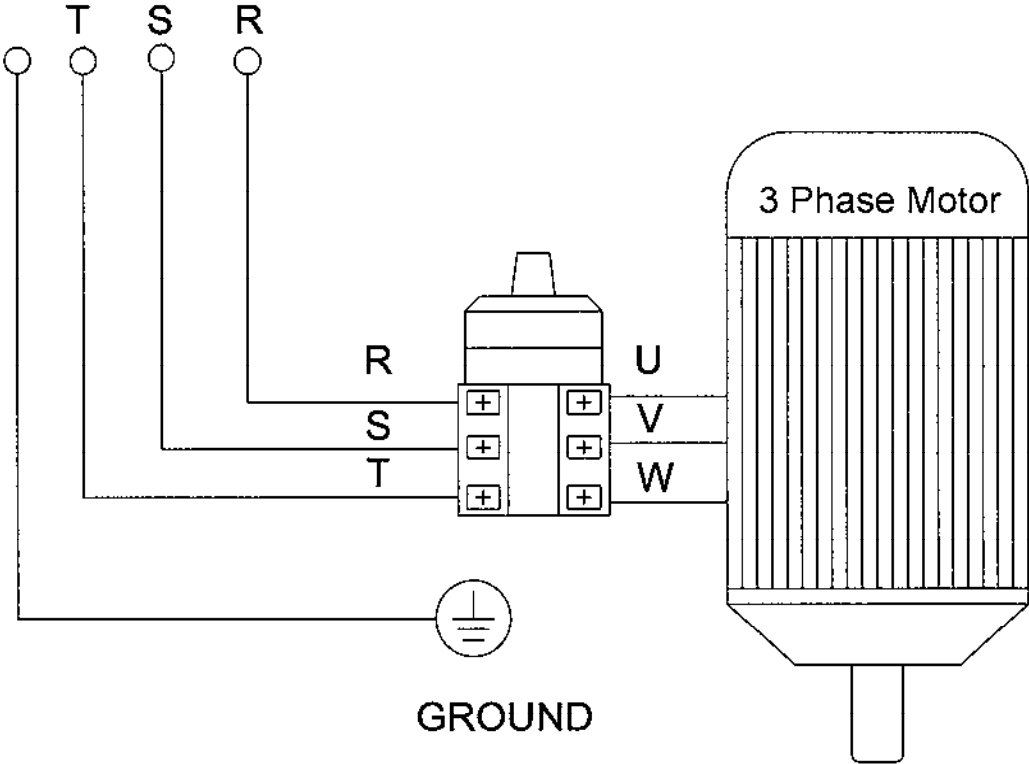

Boring Template

SCALE 1:1

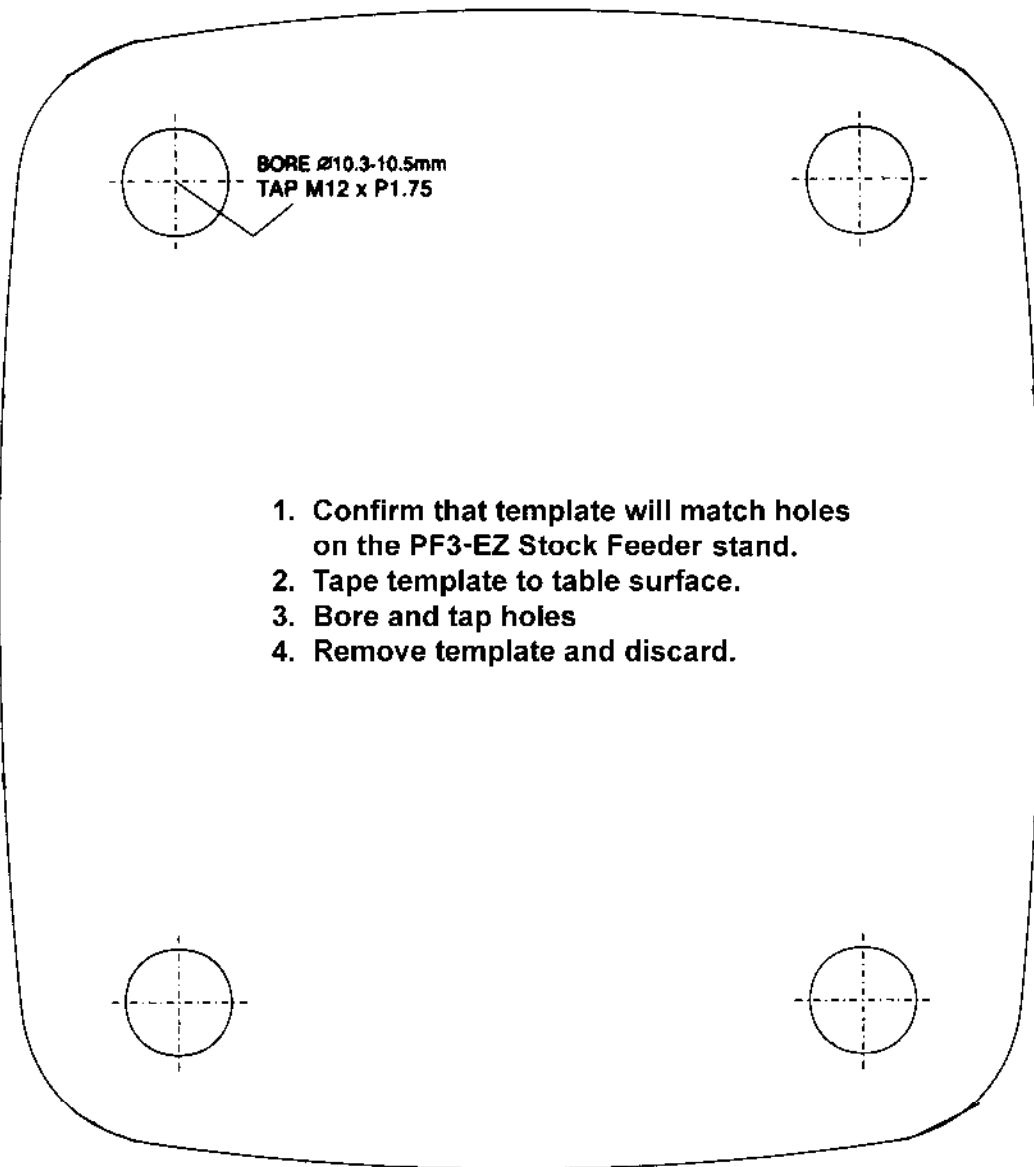



WMH Tool Group, Inc.
2420 Vantage Drive
Elgin, Illinois 60124
Phone: 800-274-6848
www.powermatic.com
www.wmhtoolgroup.com

Free Manuals Download Website

<http://myh66.com>

<http://usermanuals.us>

<http://www.somanuals.com>

<http://www.4manuals.cc>

<http://www.manual-lib.com>

<http://www.404manual.com>

<http://www.luxmanual.com>

<http://aubethermostatmanual.com>

Golf course search by state

<http://golfingnear.com>

Email search by domain

<http://emailbydomain.com>

Auto manuals search

<http://auto.somanuals.com>

TV manuals search

<http://tv.somanuals.com>