

PowerTec20



INSTRUCTION MANUAL

- OPERATION

- CARE

- SERVICE

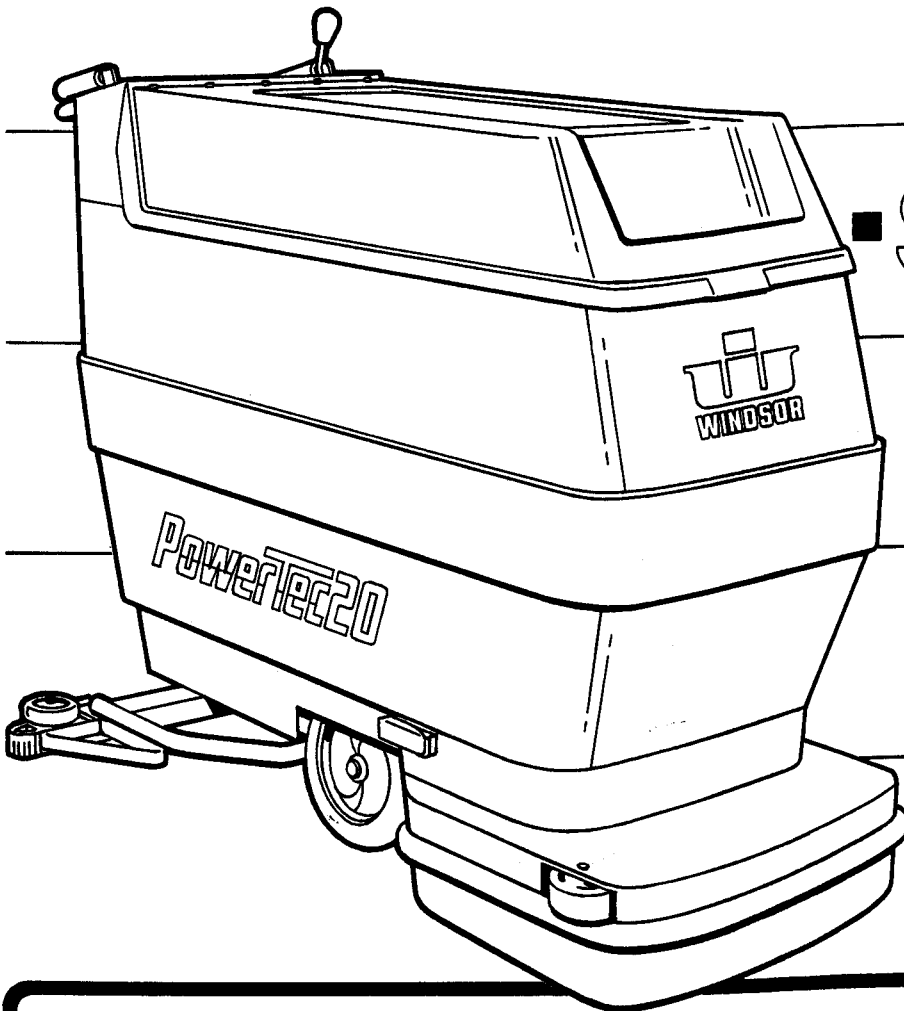

**Model PT-20
Battery Powered
Floor Scrubber**



WINDSOR INDUSTRIES, INC., 1351 W. Stanford Ave., Englewood, CO 80110 USA • 303/762-1800 • FAX 303/762-0817

Operator Safety Instructions



WARNING:

Read the instruction manual before operating this machine.

Operate this machine only from the rear of machine.

Use caution when operating the machine on a ramp or incline. Do not turn or leave this machine unattended on a ramp or incline.

Machine can cause an explosion when operated near flammable vapors and materials.

Store machine inside. Keep the electrical components of the machine dry.

Lead acid batteries generate gases which can cause an explosion. Keep sparks and flames away from the batteries. Charge the batteries only in a well ventilated area.

Wear eye protection when working near batteries. Do not put any type of metal objects across the battery terminals or on top of the batteries.

Maintenance and repairs must be done by qualified personnel only. Maintain adjustments on machine as per specifications noted in the service manual.

Make sure all warning and caution labels are legible and properly attached to the machine.

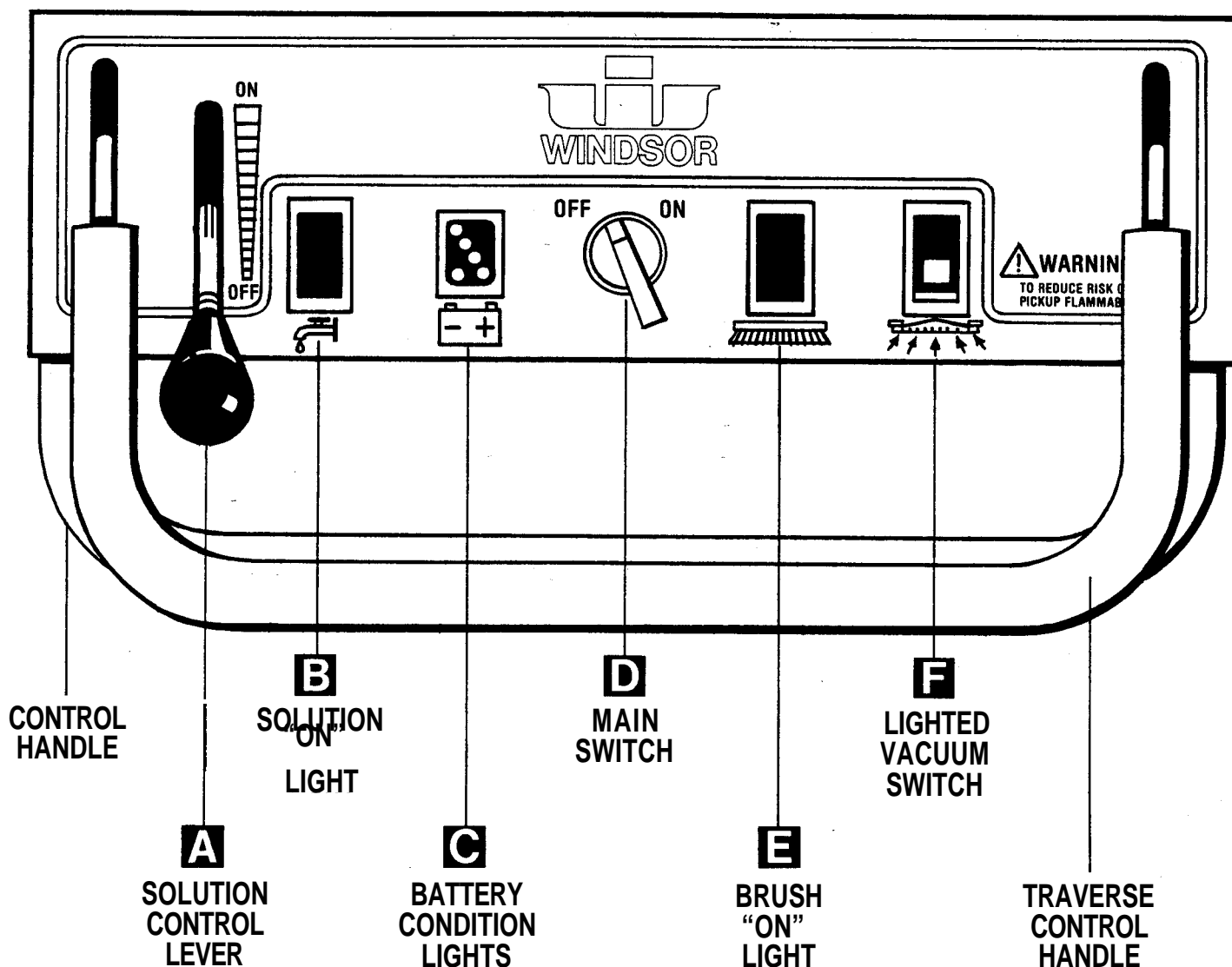

- A** Controls flow of cleaning solution to floor.
- Light "ON" indicates solution valve is open.
- C** Indicates charge condition of batteries —
 - 4 green lights — full charge — approximately 4 1/2 hours run time.
 - 1 green light — approximately 1/2 hour run time left.
- D** Switches on main drive motor and brush.
- E** Light "ON" indicates brush is turning.
- F** Lighted switch indicates vac motor is on.

MACHINE PREPARATION

BATTERIES

1. Install batteries and connect battery cables as shown.

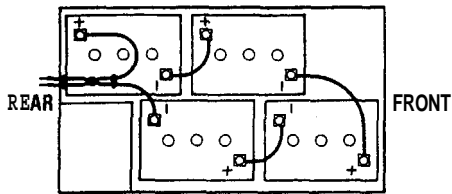

WARNING: Provide proper ventilation and leave cover open when charging batteries.

2. Charge the batteries before using the machine. (See Battery Charging Procedure)

BRUSH/DRIVE PAD ASSEMBLY

1. Remove brush cover.
2. Position brush under drive plate and lift brush to engage drive lugs in recesses in plate. A quick clockwise motion will lock brush to drive plate.

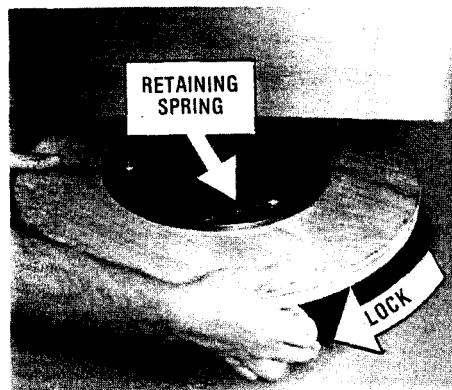

CLEANING SOLUTION

1. Fill machine with hot water and add cleaning chemical at the proportion noted on the container.

CAUTION: Always use a low sudsing cleaning chemical designed for use in automatic hard surface floor scrubbers.

OPERATING THE MACHINE

BRUSH/DRIVE PAD CONTROL

1. Push down and slightly to the left on brush lift arm to lower brush to floor (right hand pedal).

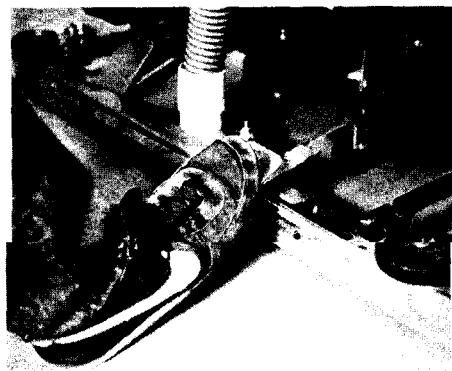

NOTE This pedal can also be used to increase brush pressure to the floor. This can be done by pulling up on the pedal and locking it in one of the positions on the brush adjustment bracket.

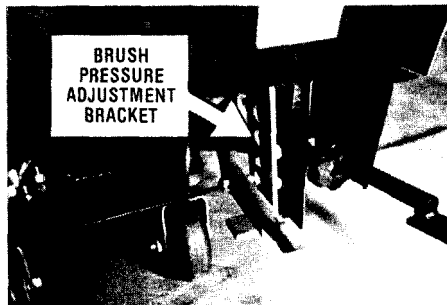

2. Switch on brush motor by turning the main switch clockwise.

CAUTION: Do not leave brush running on floor while machine is stationary.

3. Switch on vacuum switch.
4. Push solution lever forward. **NOTE:** The amount of solution can be regulated during operation depending on the type of floor and the traverse speed of the machine.

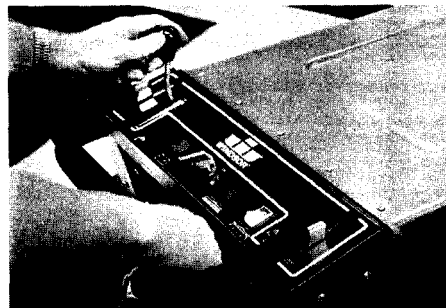

5. Push down on front of squeegee pedal to release the latch arm and lower squeegee assembly to floor.

CAUTION: Always lift squeegee before moving the machine in REVERSE to prevent damage to squeegee blades.



8. To go FORWARD press down on the traverse handle.
To STOP release the traverse handle and pull back on the control handle.
To REVERSE machine lift up on traverse handle.

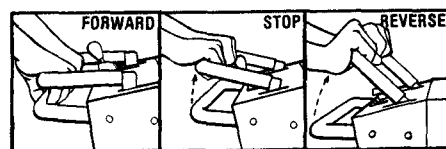

REGULAR MAINTENANCE

BEFORE STARTING WORK PERIOD

1. Disconnect battery charger. **NOTE** Disconnect the "AC" power cord from the wall receptacle before removing the "DC" charger plug from machine.
2. Check water level in batteries. Add distilled water as needed.
3. Attach brush or drive pad to drive plate.
4. Check vac motor and float for proper seal.
5. Check vac hose connection at squeegee shoe.
8. Check squeegee blades for wear.
7. Fill machine with hot water and add cleaning chemical at the proportions noted on the container. **NOTE** Use a low sudsing cleaner designed for use in automatic hard surface floor scrubbers.

BEFORE STORING MACHINE AT THE END OF WORK PERIOD:

1. Drain both solution and recovery tanks and rinse clean.
2. Lift out vac motor and float assembly to allow recovery tank to air dry.
3. Remove brush or drive pad from drive plate and store upside down or hang on wall.
4. Wipe down exterior of machine with damp cloth.
5. Raise squeegee assembly to "store" position.
8. Charge batteries. (See Battery Charging Procedure)

BATTERIES — CHARGING AND MAINTENANCE

BATTERY CHARGING PROCEDURE

WARNING: Lead acid batteries generate gases which can cause an explosion. Keep sparks and flames away from batteries. **NO SMOKING.** Always wear eye protection when working near batteries. Charge the batteries only in a well ventilated area.

1. Set the charger on a flat level surface.
2. Lift up battery compartment cover. Leave cover up during charging cycle.
3. Connect the "DC" charger plug to the connector on the machine. **NOTE** A safety override switch is activated when the "DC" charge plug is connected. This prevents all panel circuits on the machine from accidentally being switched on during charging cycle.
4. Connect charger "AC" plug to properly grounded outlet that has correct voltage for the charger.
5. The charger supplied by Windsor is totally automatic and shuts off when the batteries are fully charged.
8. After charging check electrolyte level of the batteries. Add distilled water to the level as shown in diagram. (upper right)

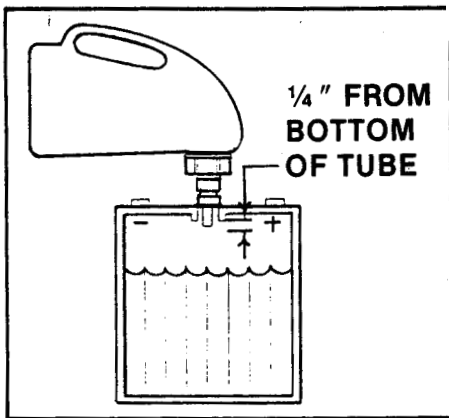

BATTERY MAINTENANCE

1. Keep tops of batteries clean and dry. Use a damp cloth with a weak solution of baking soda or ammonia and water. Use a clean dry cloth to wipe battery tops dry after cleaning.
2. If corrosion (white deposits) appears on the battery terminals and cable clamps, remove and clean. Use a battery terminal and connector cleaning tool.

BATTERY TERMINAL CLEANER

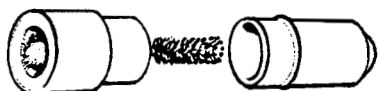

3. Keep the battery electrolyte at the correct level — approximately 1/4" below bottom of filler tube of each cell. Distilled water should be added, as needed, AFTER charging cycle.

WARNING: Do not allow electrolyte level to drop below the tops of the plates.

SERVICING THE PT-20 SCRUBBER

CAUTION: Before making any adjustments or repairs to the machine...

1. Only qualified maintenance personnel are to perform repairs.
2. Make sure battery charger is disconnected.
3. Make sure all switches are "OFF"
4. Remove batteries as required or disconnect main battery leads from batteries when making repairs to electrical system.

VACUUM MOTOR

1. Disconnect motor leads from connector and lift out vac motor.



2. Check motor brushes — when worn to 3/8" length replace both brushes.



DRIVE CHAIN

1. Remove left side skirt and side panel.
2. To remove chain, remove retaining clip and pull out master link.



3. To adjust chain tension...

A. Remove traverse drive pulley.

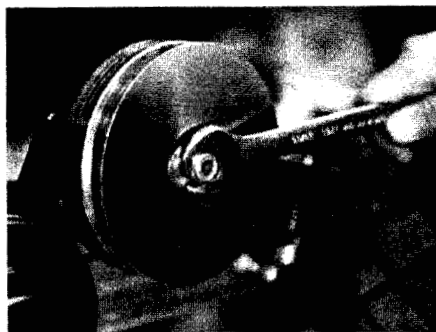

B. Loosen lock nut and back out screw (1) turn.

C. Use a hammer and punch to rotate the eccentric bushing to tighten or loosen the drive chain.

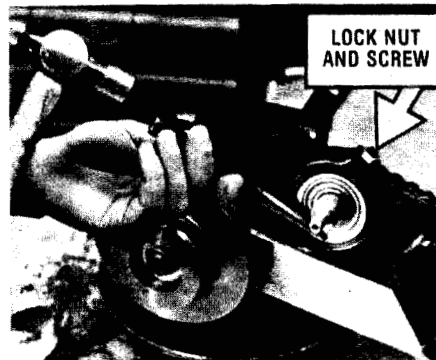

GEAR UNIT

1. Loosen belt tension screw and remove belts.

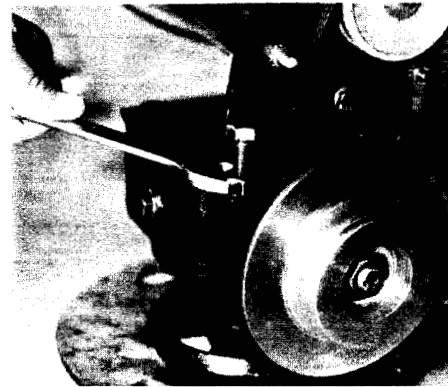

2. Remove pulley to allow removal of left hand lift arm.
3. Remove right hand pivot bolt, bushing and lift arm.

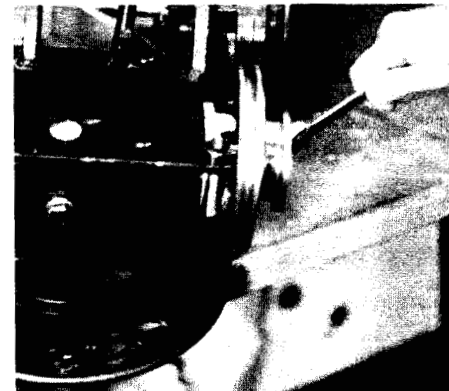

4. To check gear unit oil level — remove inspection plug; oil should be at the bottom of hole. To add oil, remove fill plug and add 90 weight oil as needed.

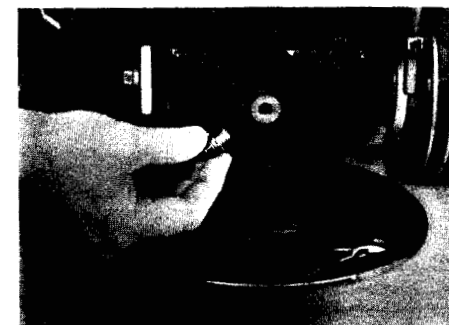

TRAVERSE DRIVE MOTOR

1. Remove lower right hand side skirt.
2. Disconnect motor leads from terminal block.
3. Remove snap ring from end of motor pivot shaft.

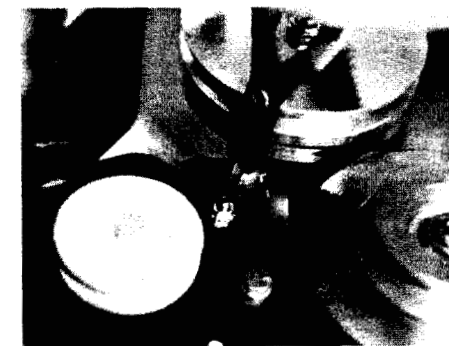

- Lift out motor — check motor brushes. When worn to $3/8$ " replace brushes.

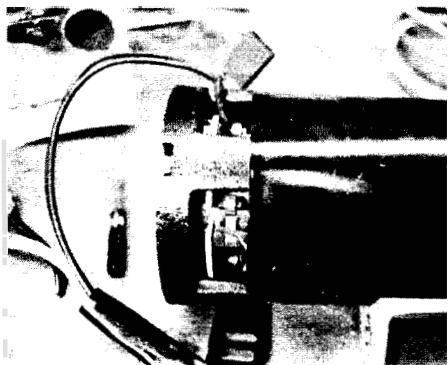

DIFFERENTIAL ASSEMBLY

NOTE: The differential assembly, traverse drive motor and brush gear unit can be removed as a total unit for servicing, if required.

- Lay machine on side or build tripod supports for each side of machine to hold unit upright as shown.

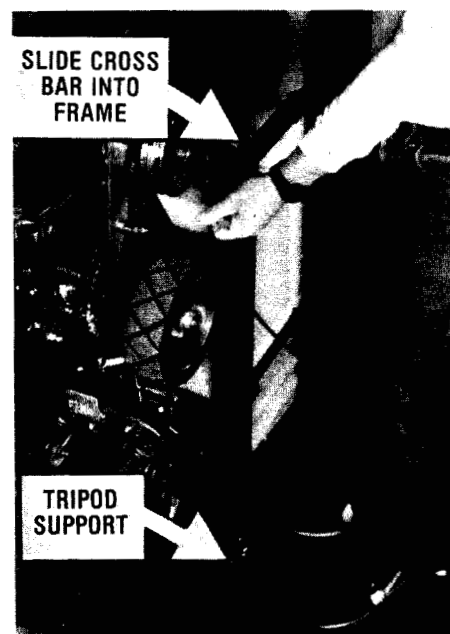

- Remove bolts from brush lift arm bracket and traverse drive connecting arm.

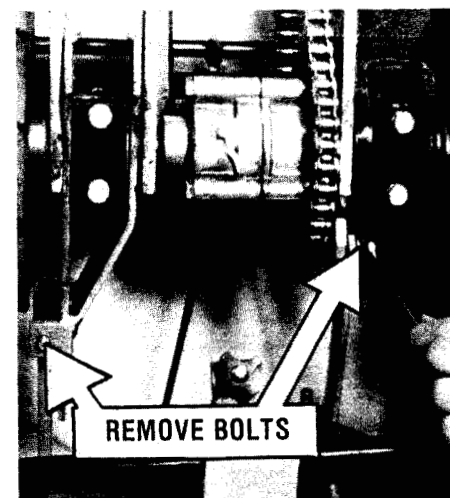

- Remove axle hub clamps. Lift off assembly and lay on bench to service.

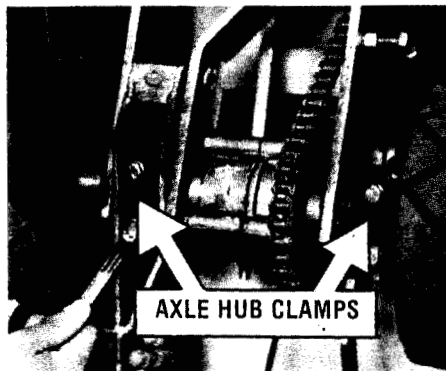

WHEEL/DIFFERENTIAL AXLE ASSEMBLY

- Remove bolt holding wheel to axle.
- Remove wheel from axle. Use wheel puller, if needed, being careful not to damage threads in center hole of axle.

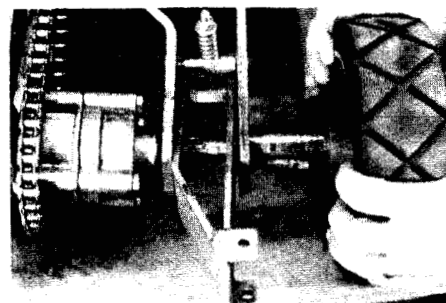

- To remove axle and bearings from hub...

- Remove snap ring from hub.
- Use an arbor press or hammer and block of wood to remove bearing and axle.

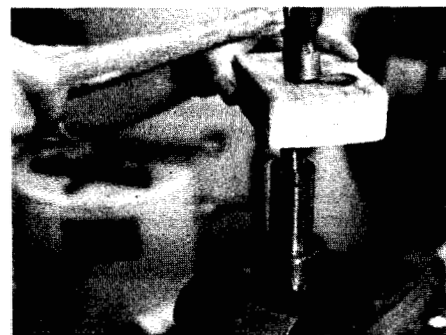

- To remove roller bearing from hub, use a piece of $3/4$ " dia. tube to drive out bearing.



SQUEEGEE ASSEMBLY

To remove squeegee assembly...

- Depress pedal to raise squeegee.
- Pull retaining pin from locator stud.
- Push down on squeegee to remove from drag arm and slide squeegee to the right to disengage right hand stud from arm.

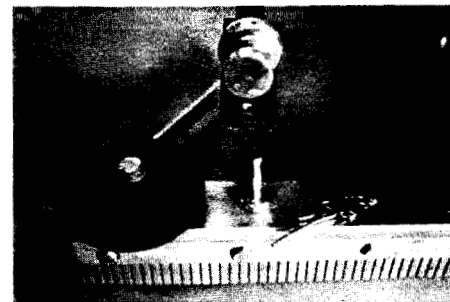

- When installing or replacing squeegee blades make sure the smooth side of the blade is next to the squeegee casting.
- Squeegee support caster — with squeegee assembly setting perpendicular to the floor surface, adjust caster to a clearance of approximately $1/8$ " between bottom of caster and the floor. As the squeegee blades wear, adjust caster to maintain this dimension.

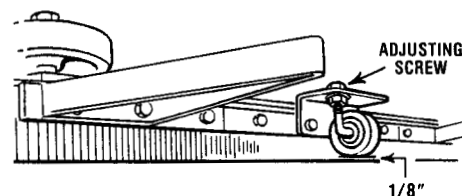

- The angle of the squeegee can be changed with the adjusting screw. Turn screw clockwise to tilt squeegee forward and counterclockwise to tilt rearward. Tighten lock nut after making adjustment.

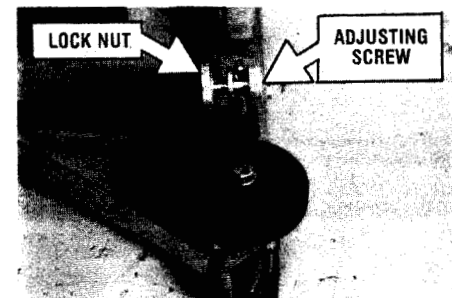

- Squeegee pressure can be changed with the adjusting screw. To increase pressure turn counterclockwise, to decrease pressure turn clockwise.

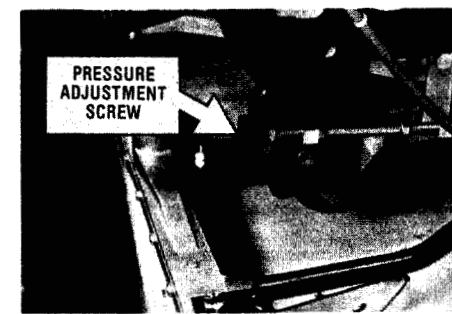

CAUTION: Operating the machine with excessive pressure on the squeegee will cause abnormal wear on the squeegee blades.

BRUSH DRIVE BELT

1. Remove traverse drive belt by rolling belt off pulley.
2. Loosen belt tension adjusting screw and remove brush drive belt. After readjusting belt tension, make sure lock nut on adjusting screw is tight.

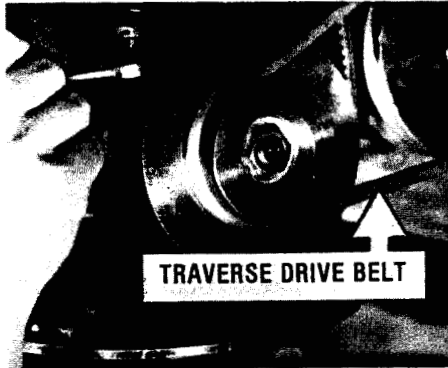

TRAVERSE DRIVE BELT

1. With operating handle in neutral position, roll belt off pulley. Replace as required.

2. After installing new belt check for clearance between traverse pulley and brush drive belt. The pulley should not be in contact with the belt when the traverse handle is in the neutral position.

To adjust clearance:

- A. Remove left side panel.
- B. Loosen lock nuts on link rod. Adjust bracket on link rod so pulley does not contact belt. Retighten lock nuts on link rod.

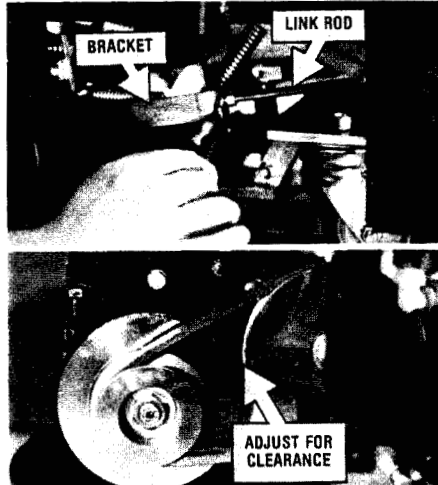

BRUSH ANGLE

ADJUSTMENT

1. Start the brush motor and lower the brush slowly to the floor. When the rear of the brush "A" touches the floor, the front of the brush "B" should be about 3/16" from the floor.
2. By releasing the foot lift pedal the springs will allow the brush to rest completely on the floor.
 - A. If the brush vibrates while in operation **Increase dirtanu "B"**.
 - B. If the machine pulls to the left during operation **decrease dirtanu "B"**.
3. The springs (C) should be adjusted so as to maintain the distances as shown.
4. To change brush inclination, **loosen** nut (D) and turn tie-rod (E) until the correct angle is reached.

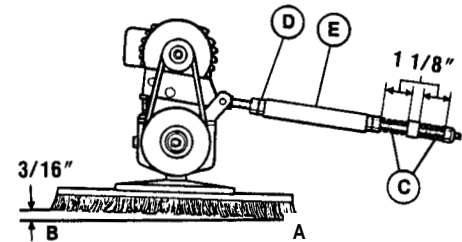

WIRING DIAGRAM

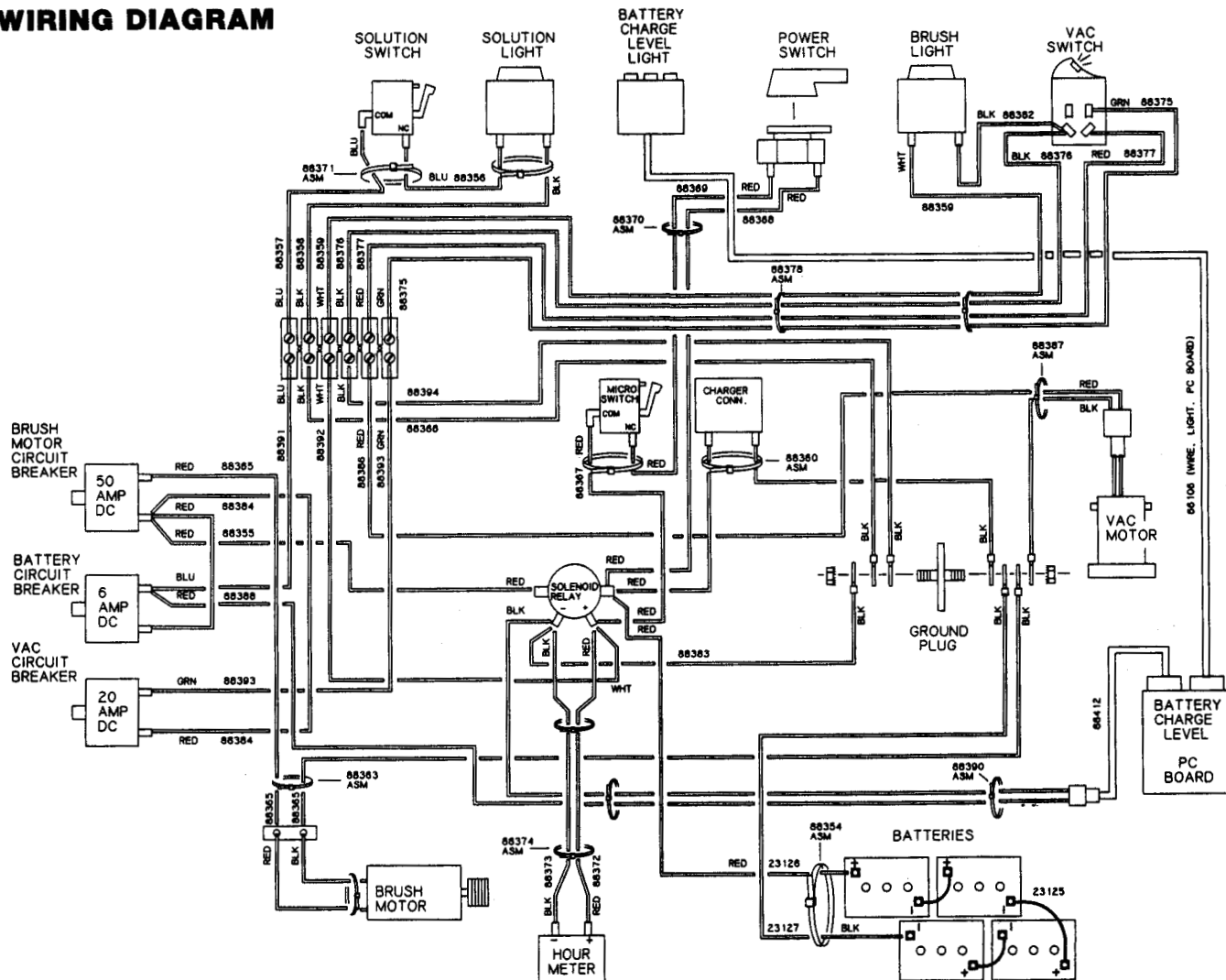

VAC, BATTERY, TANK

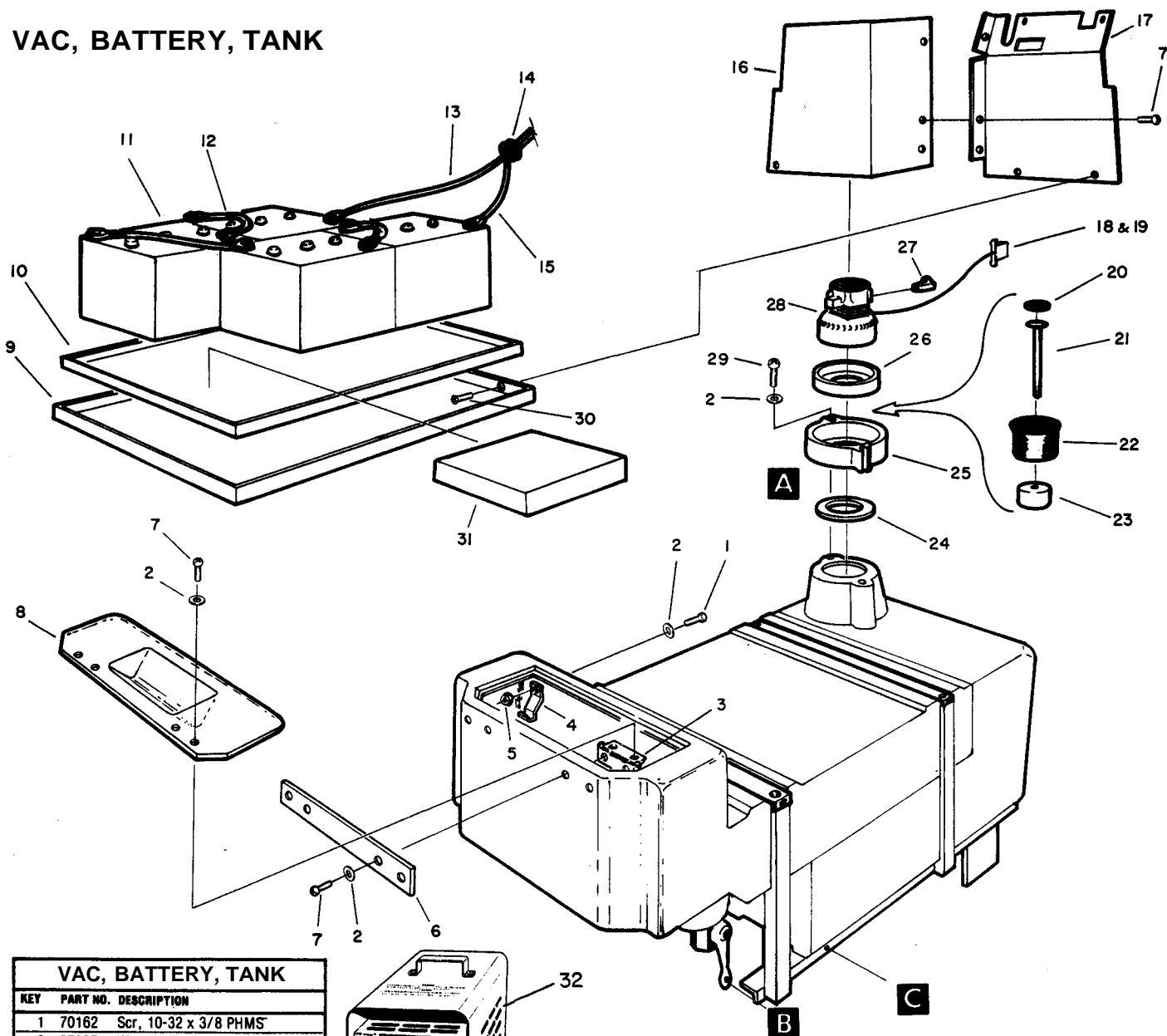

VAC, BATTERY, TANK

KEY	PART NO.	DESCRIPTION
1	70162	Scr, 10-32 x 3/8 PHMS
2	87095	Washer, #10 Flat
3	41139	Hinge, PT-20 Solution Door
4	73302	Spring, Solution Door Latch
5	57104	Nut, 10-32 w/Star Washer
6	71058	Stiffener, Solution Door Strip
7	70279	Scr, 10B x 1/2 PHSM
8	29137	Door, Solution Fill
9	78182	Tray, PT-20 Battery
10	78183	Liner, PT-20 Battery Tray
11	02090	Battery, 6VDC 220 Amp Hour
12	23125	Cable, Battery Jumper (12")
13	23127	Cable, 4 GA Black (24")
14	36020	Grommet, 5/8 ID x 1.12 OD
15	23126	Cable, 4 GA Red (24")
16	32021	Enclosure, PT-20 Vac Motor
17	61109	Panel, PT-20 Electrical
18	76014	Terminal Pin, M-Molex
19	76004	Terminal, 2 Prong M-Molex
20	73248	Seal, PT-20 Vac Shut-Off
21	67127	Rod, PT-20 Vac Float
22	73271	Screen, PT-20 Float Filter
23	34145	Float, PT-20 Vac Shut-Off
24	35089	Gasket, Vac Base Seal
25	08040	Base, Vac Motor Mounting
26	35087	Gasket, 5.7 Vac Motor
27	14548	Brush Set, PT-20 Vac Motor
28	53159	Motor, PT-20 24VDC Vac
29	70313	Scr, 10-32 x 3/4 PHMS
30	70308	Scr, 10B x 1/2 FHST
31	14549	Block, PT-20 Battery Tray
32	02093	Battery Charger 24VDC

BODYWORK

KEY	PART NO.	DESCRIPTION	KEY	PART NO.	DESCRIPTION
1	51071	Latch, Brush Shroud	28	70279	Scr, #10B PHSM
2	70088	Scr, 10-32 x 1/2 PHMS	29	41135	Hinge, PT-20 Main Cover
3	73293	Strap, Bumper Retainer	30	87018	Washer, #10 x 9/16 OD
4	73254	Shroud, PT-20 Brush	31	70011	Scr, 1/4-20 x 5/8 HHMS
5	14531	Bumper, PT-20 Brush Shroud	32	87090	Washer, 1/4 ID x 3/4 OD
6	57104	Nut, 10-32 w/Star Washer	33	71048	Support, PT-20 Cover
7	70282	Ring, 1/4 Turn Fastener Snap	34	14493	Bushing, .25 ID x .37 OD Flange
8	70281	Washer, 1/4 Turn Fastener	35	70300	Scr, 1/4-20 x 1/2 THMS
9	70280	Stud, 1/4 Turn Fastener	36	62221	Plate, Cover Support
10	70076	Scr, 10-32 x 1 FHMS	37	14533	Bracket, Cover Support
11	51074	Lug, Shroud Mounting	38	70213	Scr, 10-32 x 7/16 PHMS
12	48012	Knob, 5/16-18	39	61105	Panel, PT-20 LH Upper
13	14536	Bracket, Bumper Retainer	40	57120	Nut, 10-32 Self Retaining
14	87003	Washer, 3/8 ID x 7/8 OD	41	61111	Panel, PT-20 Rear
15	70255	Scr, 3/8-16 x 1.5 HHMS	42	14520	Bracket, Drain Hose
16	57022	Nut, 3/8-16 Lock	43	14497	Bumper, PT-20 Left
17	89059	Wheel, PT-20 Squeegee Bumper	44	34144	Frame, PT-20
18	61123	Panel Assembly, PT-20 Front Lower	45	61106	Panel, PT-20 LH Lower
19	73296	Skirt Asm, PT-20 Lower Right	46	73297	Skirt Assembly, PT-20 Lower Left
20	70111	Scr, 10-32 x 1/2 PHST	47	51073	Latch Bracket, Brush Shroud
21	87016	Washer, #10 Star	48	70283	Receptacle, 1/4 Turn Fastener
22	61104	Panel, PT-20 RH Lower	49	73294	Shield, Motor
23	14498	Bumper, PT-20 Front	50	67102	Rivet, 1/8 OD x 1/4 L AL
24	14496	Bumper, PT-20 Right	51	73353	Spacer, PT-20 Shroud Stop
25	61103	Panel, PT-20 RH Upper	52	70066	Scr, 10-32 x 3/4 PHMS
26	61107	Panel, PT-20 Front Upper	53	87029	Washer, 5/16 ID x 3/4 OD
27	27292	Cover, PT-20 Top Hood			

BODYWORK

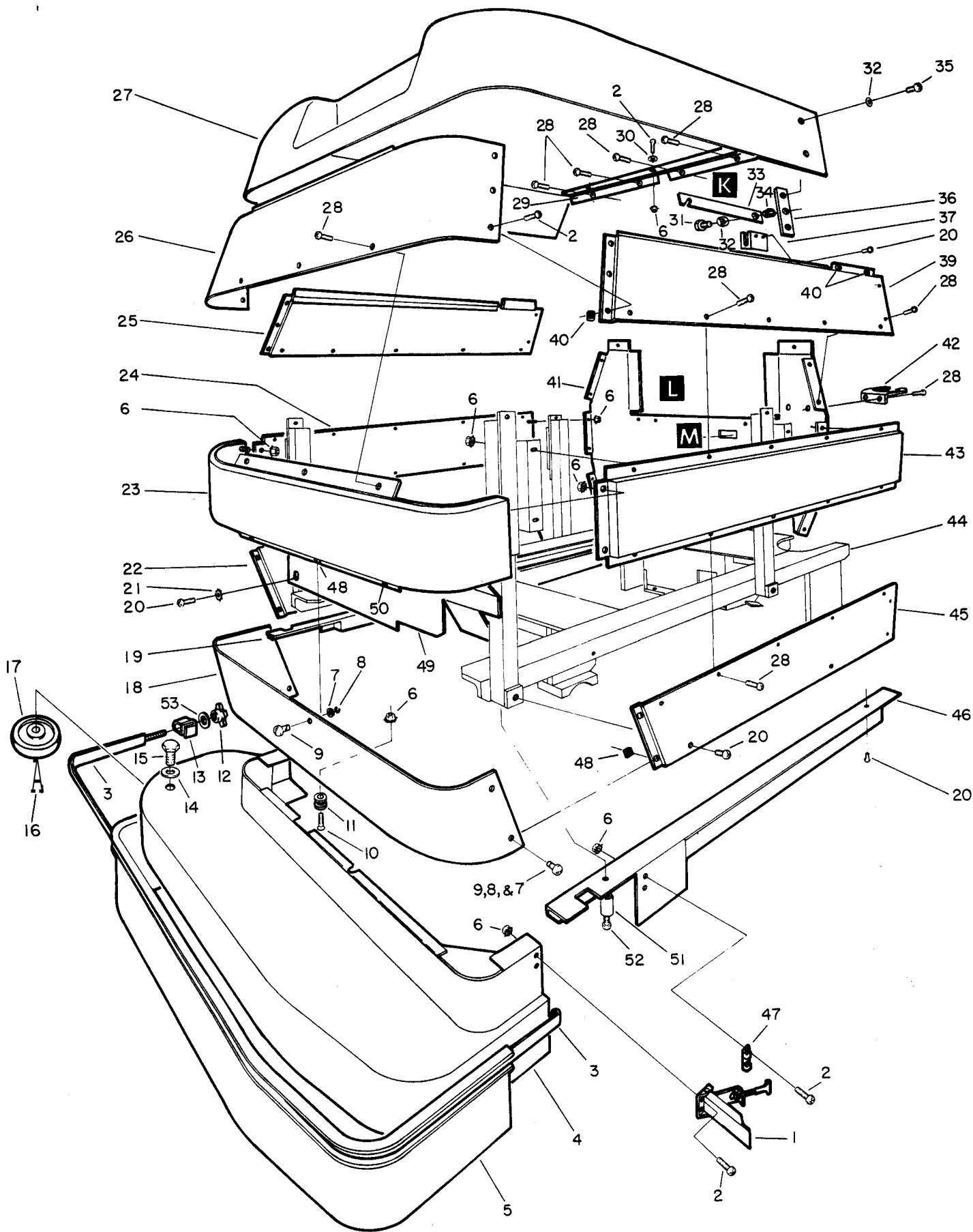

MAINFRAME/TANKS

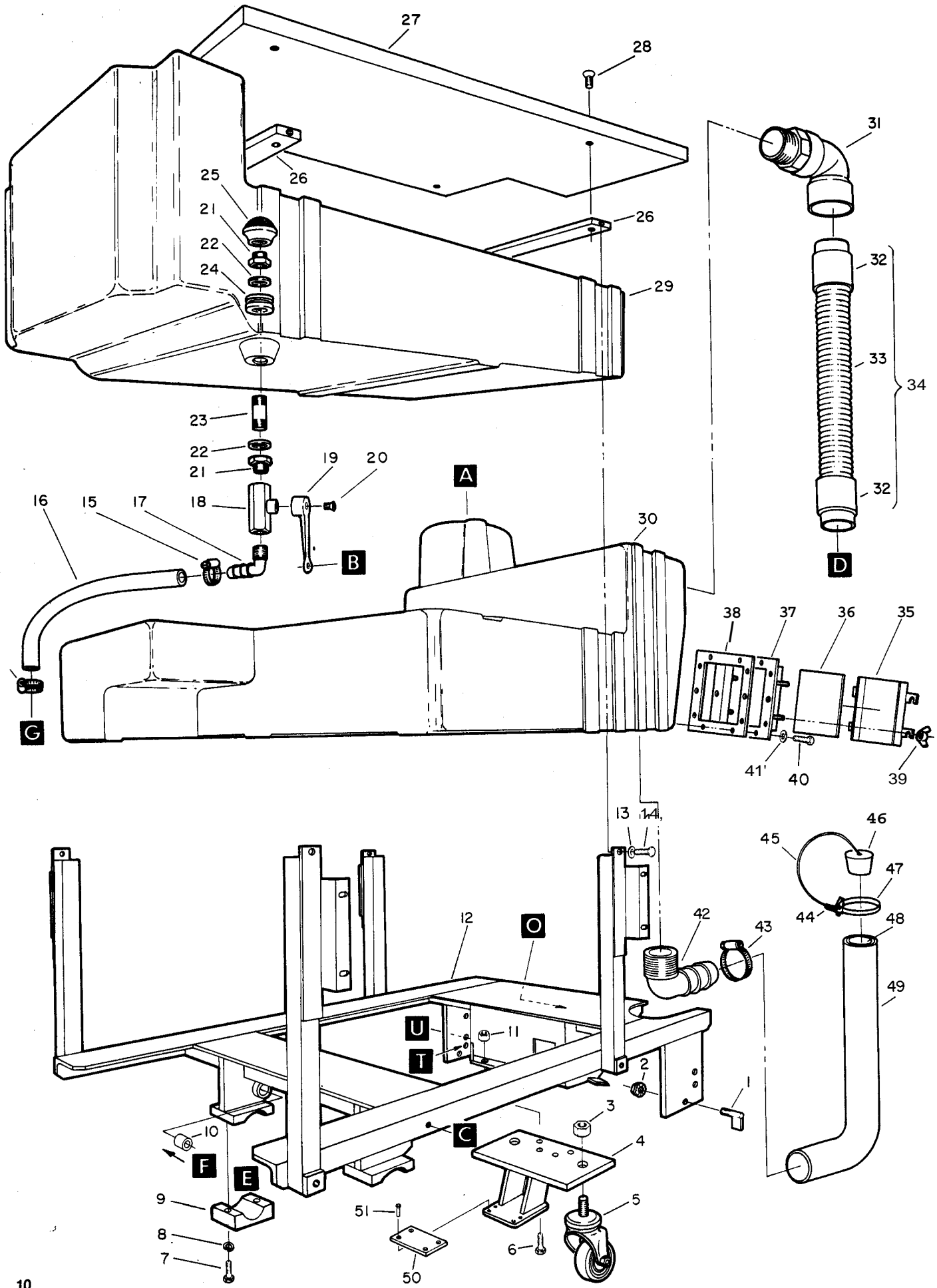

SQUEEGEE w/ARM

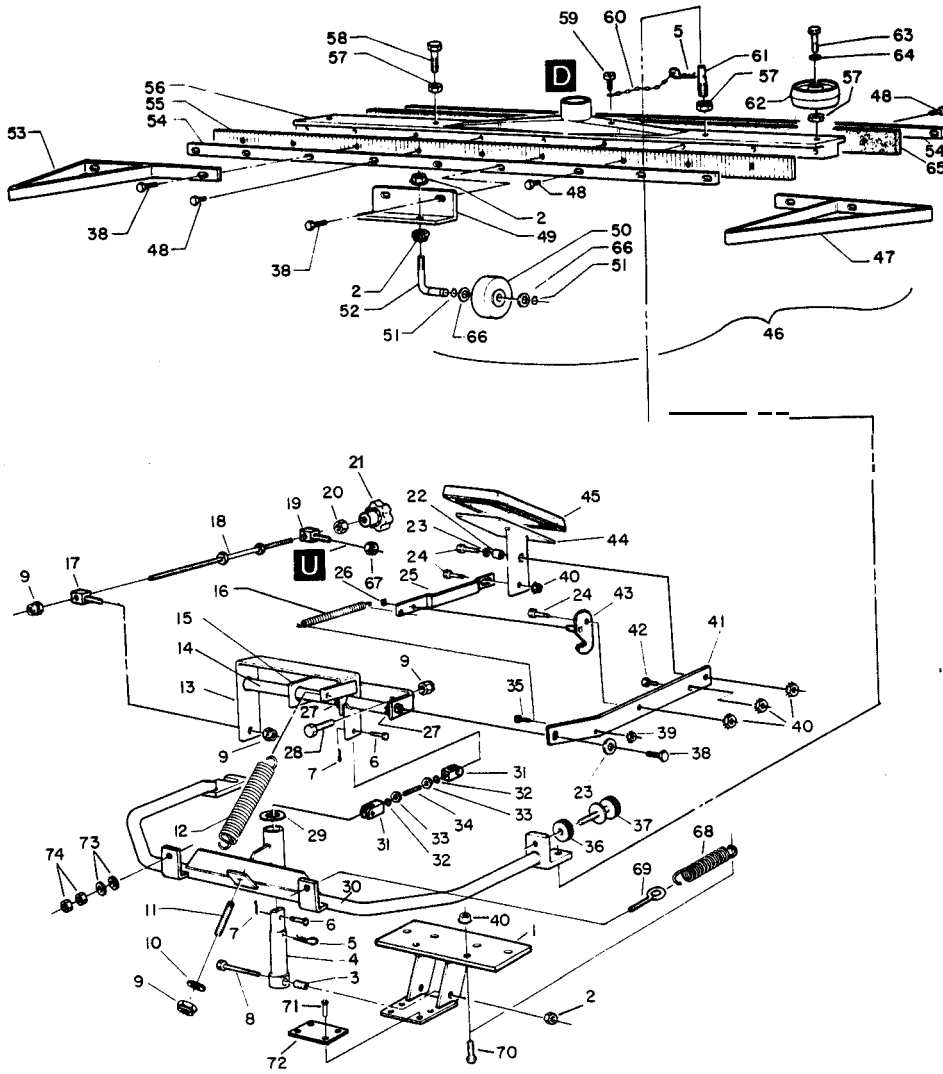

SQUEEGEE w/ARM

KEY	PART NO.	DESCRIPTION
1	71044	Support, Caster and Squeegie
2	57112	Nut, 5/16-18 Flange PLTD
3	14485	Bushing, Squeegie Support
4	66107	Pin, Squeegie Arm Mounting
5	66092	Pin, Hair Spring Cotter
6	66116	Pin, Clevis
7	66121	Pin, 3/32 x 1/2 Cotter
8	70259	Scr, 5/16-18 x 1.75 HHCS
9	57113	Nut, 5/16-18 Lock
10	87090	Washer, 1/4 ID x 3/4 OD
11	67119	Rod, Squeegie Arm Tension
12	73265	Spring, Squeegie Arm Tension
13	14478	Brkt, Squeegie Linkage Support
14	51065	Linkage, Squeegie Lift Arm
15	14480	Brkt, Squeegie Linkage Mtg
16	73266	Spring, Squeegie Pedal Lock
17	14475	Block, Camber Adj Threaded
18	67116	Rod, Camber Adj
19	14476	Block, Camber Adj Support
20	57031	Nut, 5/16-18 Hex
21	48012	Knob, 5/16-18
22	14492	Bushing, .25 ID x .375 OD x .25
23	87090	Washer, 1/4 ID x 3/4 OD
24	70270	Scr, 1/4-20 x 3/4 HHCS
25	05027	Arm, Squeegie Pedal Lock
26	67105	Ring, 1/4 Ext Snap
27	67104	Ring, 5/8 Ext Snap H-D
28	70083	Scr, 5/16-18 x 1.00 HHMS
29	87088	Washer, 5/8 ID x 1.00 OD
30	05045	Arm, PT-20 Squeegie
31	27277	Clevis, 5/16-24 UNF Rod
32	87096	Washer, 5/16 Int Lock-Lite
33	57127	Nut, 5/16-24 Hex Jam
34	70301	Stud, 5/16-24 x 1.25
35	70066	Scr, 10-32 x 3/4 PHMS
36	57124	Nut, Squeegie Camber Lock
37	48032	Knob, Squeegie Camber Adj
38	70011	Scr, 1/4-20 x 5/8 HHMS
39	57104	Nut, 10-32 w/Star Washer
40	57105	Nut, 1/4-20 w/Star Washer
41	05032	Arm, Squeegie Lift
42	70271	Scr, 1/4-20 x 1/2 HHMS
43	51063	Latch, Squeegie Pedal
44	66104	Pedal, Squeegie
45	66109	Pad, Pedal
46	73257	Squeegie Assembly, PT-20
47	14488	Bumper, Squeegie Left
48	70020	Scr, 1/4-20 x 1/2 HHMS
49	14482	Bracket, Squeegie Wheel
50	89058	Wheel, PT-20 Roller
51	67103	Ring, 5/16 Ext Snap
52	66108	Pin, Squeegie Wheel
53	14487	Bumper, Squeegie Right
54	67120	Retainer, Squeegie Blade
55	73273	Squeegie Blade, PT-20 Front
56	73259	Shoe, PT-20 Squeegie
57	57085	Nut, 3/8-16 Hex Jam
58	70257	Scr, 3/8-16 x 1.0 HHCS
59	70098	Scr, 8-32 x 3/8 PHST F
60	27295	Chain, PT-20 Squeegie
61	14483	Bolt, Squeegie Stud
62	89059	Wheel, PT-20 Bumper
63	70255	Scr, 3/8-16 x 1.5 HHMS
64	87003	Washer, 3/8 ID x 7/8 OD
65	73274	Squeegie Blade, PT-20 Rear
66	87029	Washer, 5/16 ID x 3/4 OD
67	57138	Nut, 5/16-18 Hex Jam
68	73358	Spring, PT-20 Squeegie Align
69	70263	Bolt, 8-32 x 1.0, 1/4 Eye
70	70057	Scr, 1/4-20 x 1 RHMS
71	70177	Scr, 10-32 x 1/2 FHMS
72	66128	Pad, Squeegie Support
73	87095	Washer, #10 Flat
74	57026	Nut, 8-32 Lock

MAIN FRAME w/TANKS

KEY	PART NO.	DESCRIPTION	KEY	PART NO.	DESCRIPTION
1	73298	Stop, Squeegie	27	78182	Tray, PT-20 Battery
2	57112	Nut, 5/16-18 Flange Hex	28	70166	Scr, 1/4-20 x 1/2 FHMS
3	57118	Nut, 1/2-13 UNC Nylock	29	75126	Tank, PT-20 Solution
4	71044	Support, Caster and Squeegie	30	75127	Tank, PT-20 Recovery
5	18023	Caster, PT-20	31	78192	Tube, Vac Inlet
6	70257	Scr, 3/8-16 x 1.0 HHCS PLTD	32	27282	Cuff, 1.5 Slip x 1.5 Hose
7	70259	Scr, 5/16-18 x 1.75 HHCS	33	39306	Hose, 1.5 Vac x 17"
8	87083	Washer, 5/16 Split Lock	34	39307	Hose Assembly, PT-20 Vac
9	14468	Block, PT-20 Axle Mount	35	29138	Door, Cleanout
10	14494	Bushing, Drive Linkage Arm	36	35088	Gasket, Cleanout Door
11	57119	Nut, 3/8-16 Lock	37	34151	Frame, Cleanout
12	34144	Frame, PT-20	38	35091	Gasket, Cleanout Door Frame
13	87090	Washer, 1/4 ID x 3/4 OD	39	57037	Nut, 1/4-20 Wing
14	70271	Scr, 1/4-20 x 1/2 HHMS	40	70088	Scr, 10-32 x 1/2 PHMS
15	20042	Clamp, 1/2 Hose D-Slot	41	87095	Washer, #10 Flat
16	39301	Hose, 1/2 ID Clear x 1/2 x 12"	42	40036	Hosebarb, 1.5 MPT x 1.5 OD
17	40027	Hosebarb, 3/8 MPT x 1/2 90D Nyl	43	20046	Clamp, 2.25 Wormgear
18	84075	Valve, 3/8 FPT Ball	44	34017	Ferrule, #1700 Rope
19	38135	Handle, Valve	45	99807	Cord, 1/8" x 12"
20	70091	Scr, 10-24 x 1/2 FHMS	46	66051	Plug, Drain Hose
21	14076	Bushing, 3/8 MPT x 1/4 FPT	47	20002	Clamp, 2" Nyl Ratchet
22	87010	Washer, 9/16 x 1.25 OD x .06	48	40019	Hosebarb, 1.5 Drain
23	56014	Nipple, 1/4 Close	49	39037	Hose, 1.5 Drain x 20"
24	36055	Grommet, 1/2 ID x 1/4 Groove	50	66128	Pad, Squeegie Support
25	73063	Strainer, 40 Mesh	51	70177	Scr, 10-32 x 1/2 FHMS
26	71039	Support, Battery Tray			

CONTROLS (MECHANICAL)

CONTROLS (MECHANICAL)

KEY	PART NO.	DESCRIPTION
1	05029	Arm, Drive Linkage Adj
2	70015	Scr. 1/4-20 x 3/4 HHMS
3	87090	Washer, 1/4 ID x 3/4 OD
4	14492	Bushing, .25 ID x .37 OD x .25
5	70270	Scr. 1/4-20 x 3/4 HHCS
6	05030	Arm, Drive Linkage
7	70260	Scr., M6 x 16 HHMS
8	87087	Washer, M6 x 25
9	14493	Bushing, .25 ID x .37 OD
10	57105	Nut, 1/4-20 Hex w/Star Washer
11	05033	Arm, Linkage Transfer
12	14491	Bushing, .25 ID x .62 OD
13	70265	Scr. 1/4-20 x 3/4 SHCS
14	73268	Spring, Drive Linkage
15	57117	Nut, 5/16-24 Hex
16	67114	Rod, Drive Linkage
17	87096	Washer, 5/16 Int Lock-Lite
18	27277	Clevis, 5/16-24 UNF Rod
19	66116	Pin Clevis, 1/4 x 3/4
20	66121	Pin, 3/32 x 1/2 Cotter
21	70273	Shoulder Bolt, 3/8 x 1.00
22	87003	Washer, 3/8 ID x 7/8 OD
23	90002	Yoke, PT-20 Drive Linkage
24	57112	Nut, 5/16-18 Flange
25	57104	Nut, 10-32 w/Star Washer
26	67122	Rod, Drive Linkage
27	14509	Bracket, RH Drive Handle Mtg
28	62190	Plate, PT-20 Support
29	62211	Plate, Drive Handle Arm
30	70085	Scr. 1/4-20 x 1/2 PHMS
31	57047	Nut, 1/4-20 Lock
32	61102	Panel, PT-20 Control
33	70054	Scr. 8-32 x 3/8 FHMS
34	38131	Handle, PT-20 Drive
35	36084	Grip, PT-20 Drive
36	48030	Knob, PT-20 Solution Lever
37	38133	Handle, PT-20 Main
38	70057	Scr. 1/4-20 x 1.00 RHMS

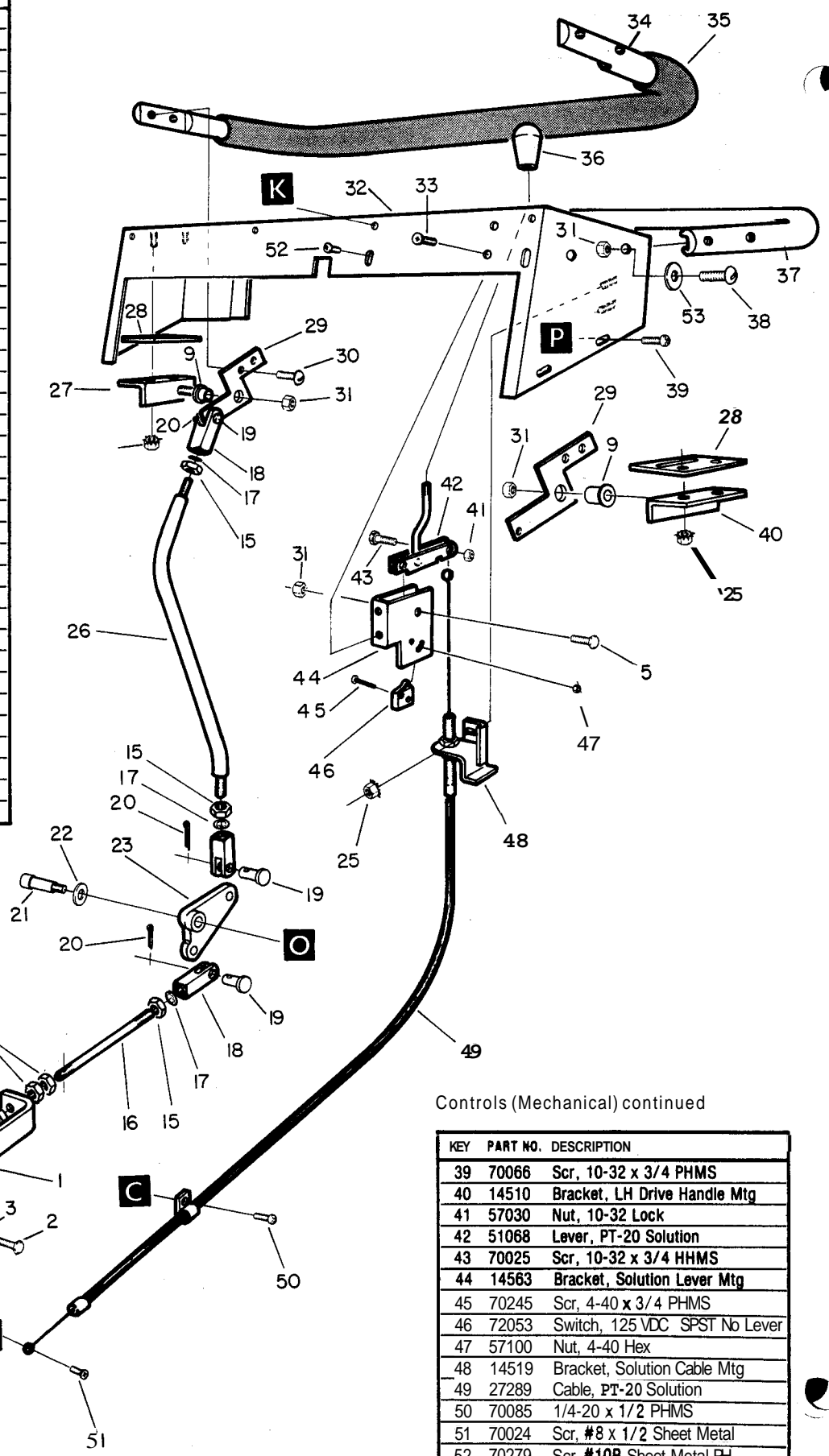

Controls (Mechanical) continued

KEY	PART NO.	DESCRIPTION
39	70066	Scr. 10-32 x 3/4 PHMS
40	14510	Bracket, LH Drive Handle Mtg
41	57030	Nut, 10-32 Lock
42	51068	Lever, PT-20 Solution
43	70025	Scr. 10-32 x 3/4 HHMS
44	14563	Bracket, Solution Lever Mtg
45	70245	Scr. 4-40 x 3/4 PHMS
46	72053	Switch, 125 VDC SPST No Lever
47	57100	Nut, 4-40 Hex
48	14519	Bracket, Solution Cable Mtg
49	27289	Cable, PT-20 Solution
50	70085	1/4-20 x 1/2 PHMS
51	70024	Scr. #8 x 1/2 Sheet Metal
52	70279	Scr. #10B Sheet Metal PH
53	87029	Washer, 5/16 ID x 3/4 OD

CONTROLS (ELECTRICAL)

KEY	PART NO.	DESCRIPTION	KEY	PART NO.	DESCRIPTION	KEY	PART NO.	DESCRIPTION
1	61112	Panel, PT-20 Rear Access	29	70245	Scr, 4-40 x 3/4 PHMS	40	51061	Light, PT-20 Blue Solution
2	57015	Nut, 1/2-24 Panel	30	70016	Scr, 6-32 x 3/4 RHMS	41	51066	Light, Battery Charge Level
3	41117	Hinge	31	88387	Wire Asm, PT-20 Vac Motor	42	72051	Switch, PT-20 Main Rotary
4	57104	Nut, 10-32 w/Star Washer	32	76071	Term Strip, 300V 20A 6 POS	43	51060	Light, PT-20 Main Red
5	14503	Breaker, 20A 50VDC Circuit	33	61109	Panel, PT-20 Electrical	44	72052	Switch, 28VDC Green Light Rocker
6	14502	Breaker, 6A 50VDC Circuit	34	32021	Enclosure, PT-20 Vac Motor	45	70283	Receptacle, 1/4 Turn Fastener
7	14522	Breaker, 50A 28VDC Circuit	35	27049	Cable Tie, 7"	46	57107	Nut, M22.5 Blk Nylon
8	32025	Enclosure, PT-20 Electrical	36	23127	Cable, 4 GA Black x 24"	47	72050	Switch, Rotary Contact Block
9	88412	Wire Asm, PT-20 Battery Card	37	23126	Cable, 4 GA Red x 24"	48	70282	Ring, 1/4 Turn Fastener Snap
10	32026	Enclosure Lid, PT-20 Electrical	38	36020	Grommet, 5/8 ID x 1.12 OD	49	70281	Washer, 1/4 Turn Fastener
12	66106	PC Board, Battery Level	39	61102	Panel, PT-20 Control	50	70280	Stud, 1/4 Turn Fastener
13	70318	Scr, #6 x 1/4 PHST						
14	57105	Nut, 1/4-20 w/Star Washer						
15	67118	Relay, 24VDC Start Solenoid						
16	20035	Clamp, 7/15 Plastic Cable						
17	57127	Nut, 5/16-24 Hex Jam						
18	70056	Scr, 6-32 x 1/2 PHMS						
19	54092	Meter, Hour						
20	87026	Washer, #6 Star						
21	57012	Nut, 6-32 Hex						
22	57125	Nut, 5/16-18 Brass						
23	87092	Washer, 3/16 ID x 3/4 OD Brass						
24	70289	Stud, 5/16-18 x 1.75 Brass						
25	36019	Grommet, 5/16 ID x 9/16 GRV OD						
26	57100	Nut, 4-40 Hex						
27	72053	Switch, 125 VDC SPST No Lever						
28	88360	Wire Asm, PT-20 Battery Charge						

CONTROLS (ELECTRICAL)

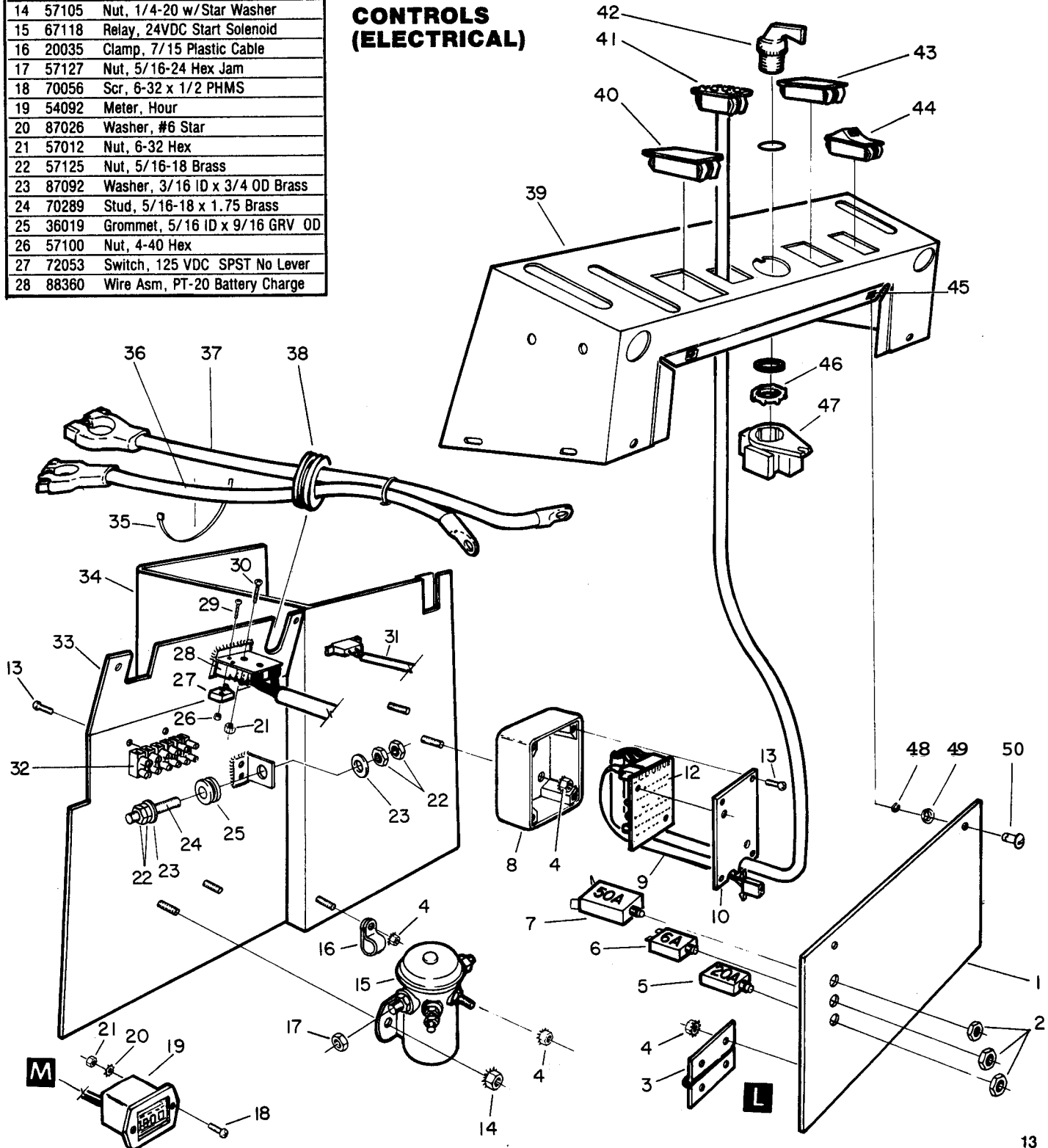

CHAIN DRIVE/DIFFERENTIAL

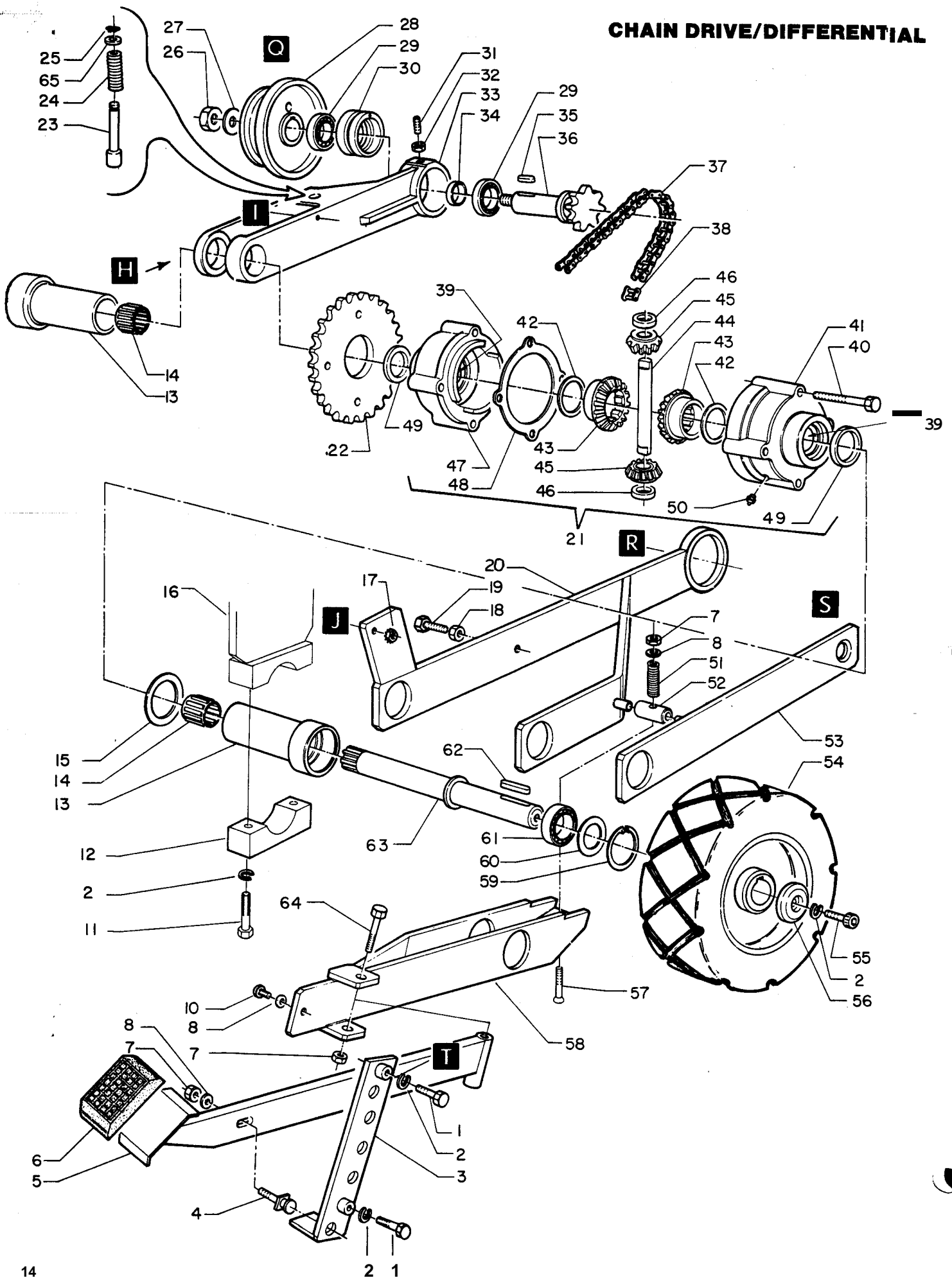

CHAIN DRIVE/DIFFERENTIAL

KEY	PART NO.	DESCRIPTION
1	70302	Scr, 5/16-18 x 1.00 HHCS
2	87083	Washer, 5/16 Split Lock
3	14474	Bracket, Brush Height Adj.
4	66101	Pin, Brush Height Lock
5	66099	Pedal, PT-20 Drive
6	66109	Pad, Pedal
7	57113	Nut, 5/16-18 Lock
8	87090	Washer, 1/4 ID x 3/4 OD
10	70319	Scr, 5/16-18 x 1/2 THMS
11	70259	Scr, 5/16-18 x 1.75 HHCS
12	14468	Block, PT-20 Axle Mounting
13	71045	Support, PT-20 Axle Shaft
14	09027	Bearing, PT-20 Axle Roller
15	73261	Spacer, Axle Shaft
16	34144	Frame, PT-20
17	57105	Nut, 1/4-20 Hex w/Star Washer
18	57111	Nut, 3/8-16 Hex
19	70255	Scr, 3/8-16 x 1.50 HHCS
20	05025	Arm, LH Brush Lift
21	36077	Gearbox Asm, PT-20 Differential
22	36078	Gear, Differential Crown
23	66102	Pin, Reverse Drive
24	73269	Spring, Reverse Drive Pin
25	67103	Ring, 5/16 Ext Snap
26	57110	Nut, M10 Lock
27	87086	Washer, M10 x 30
28	64045	Pulley, PT-20 Intermediate
29	09029	Bearing, PT-20 Pinion Gear
30	41134	Hub, PT-20 Eccentric
31	70276	Set Scr, M8 x 25 Dog Point
32	57068	Nut, M8 Hex
33	05034	Arm, Intermediate
34	73263	Spacer, Pinion Gear
35	48035	Key, 6 x 6 x 14mm
36	73258	Shaft, PT-20 Pinion Gear
37	27293	Chain, PT-20 Drive
38	27294	Masterlink, PT-20 Chain
39	14547	Bushing, PT-20 Differential
40	70307	Scr, M8 x 80
41	41146	Housing, PT-20 Right Differential
42	73310	Shim, PT-20 Differential
43	36085	Gear, PT-20 Crown Wheel
44	66120	Pin, Planet Wheel
45	36086	Gear, PT-20 Planetary
46	87097	Washer, PT-20 Thrust
47	41147	Housing, Differential PT-20 Left
48	35092	Gasket, Differential
49	73309	Seal, M20-28-4 Oil
50	90003	Zerk, Grease M6 x 1
51	73272	Spring, Balance Arm
52	73256	Spacer, Brush Lift Arm
53	05028	Arm, RH Brush Lift
54	89057	Wheel, PT-20 Main
55	70254	Scr, M8 x 18 SHCS
56	87091	Washer, PT-20 Wheel
57	70256	Scr, 5/16-18 x 3.50 Socket FHMS
58	05026	Arm, Balance
59	73260	Ring, PT-20 Axle Shaft Snap
60	73262	Shim, PT-20 Axle Shaft
61	09028	Bearing, PT-20 Axle
62	48034	Key, 6 x 6 x 28 mm
63	03044	Axle, PT-20
64	70093	Scr, 5/16-18 x 2.75 HHMS
65	87029	Washer, 5/16 ID x 3/4 OD

*Washer 64045
W/ WED PRENE*

PT-20 LABELS

PART NO.	DESCRIPTION	LOCATION
50351	Battery Warning	Under hood
50349	PowerTec 20	Lower sides
50353	PT-20 Windsor Logo	Front upper
50359	PT-20 Rear Access Panel	Circuit breakers
50360	PT-20 Brush Pedal	Lower right rear of machine
50361	PT-20 Cleanout Door	Cleanout door
50363	PT-20 Solution Warning	Front outside hood
50377	PT-20 Charger Warning	Charger connection inside cover
50378	Instruction Card	On handle
50387	Maintenance	Under hood

BRUSH DRIVE

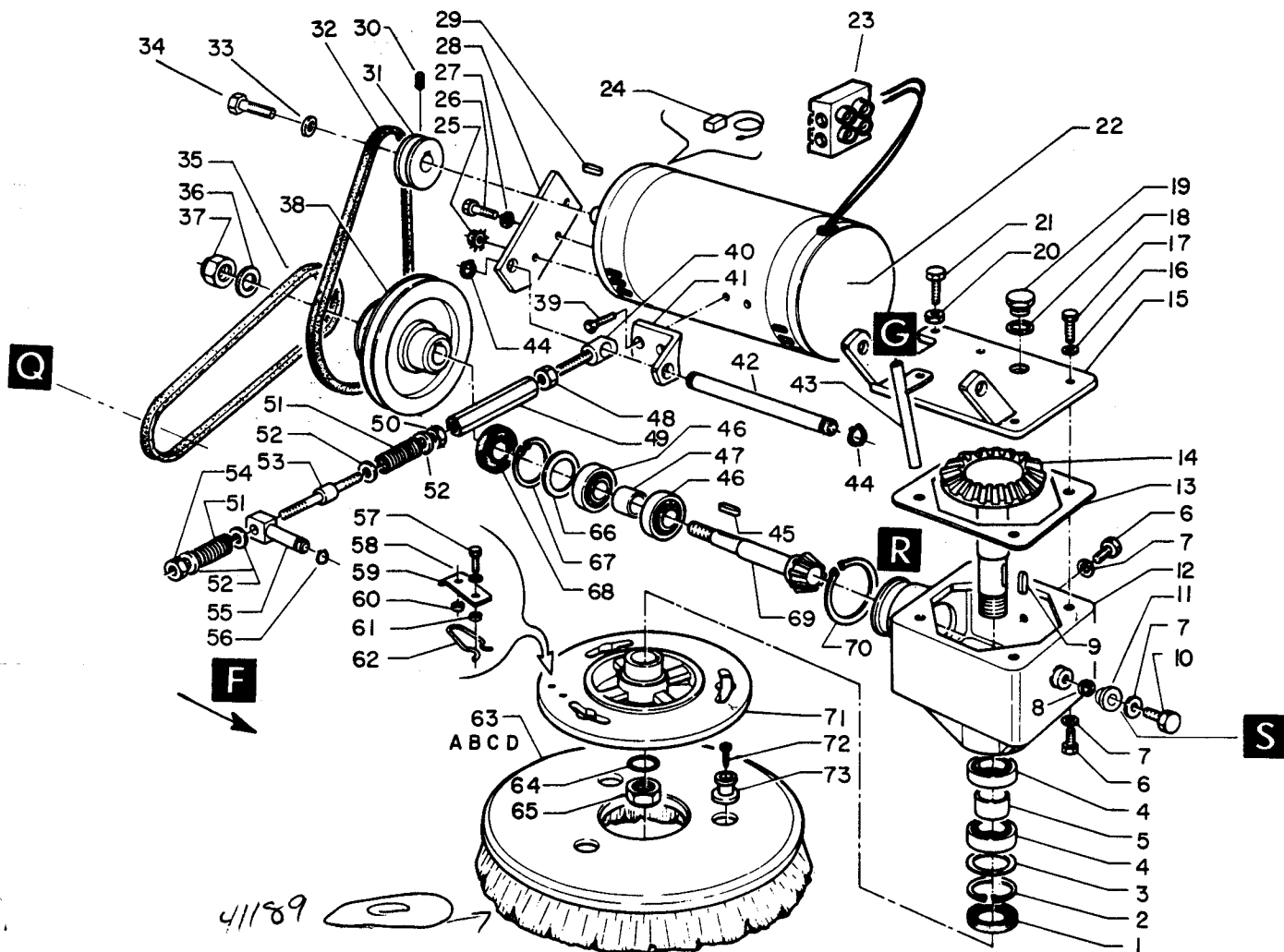

74 - Reduction Gearbox Assembly

BRUSH DRIVE

KEY	PART NO.	DESCRIPTION	KEY	PART NO.	DESCRIPTION	KEY	PART NO.	DESCRIPTION
1	73312	Seal, M38 x 57 x 7 Oil	27	87083	Washer, 5/16 Split Lock	53	67112	Rod, Turnbuckle Sliding
2	67142	Ring, M52 Int Snap	28	62199	Plate, Drive Motor Mounting	54	57022	Nut, 3/8-16 Lock
3	73314	Shim, PT-20 Reduction	29	48036	Key, 3/16 x 3/16 x 1.00	55	66105	Pin, Turnbuckle
4	09031	Bearing, PT-20 Reduction 6205	30	70314	Set Scr, 5/16-18 x 3/8 KCP	56	67104	Ring, 5/8 Ext Snap H-D
5	73315	Spacer, PT-20 Reduction	31	64043	Pulley, PT-20 Drive Motor	57	70260	Scr, M6 x 16
6	70310	Scr, M10 x 10 HHMS	32	11021	Belt, PT-20 Secondary Brush	58	87056	Washer, M6
7	87086	Washer, M10 ID	33	87008	Washer, 1/4 ID x 1.25 OD	59	20068	Clamp, PT-20 Brush
8	59019	O-Ring, 3/8 ID x 3/16 BUNA-N	34	70020	Scr, 1/4-20 x 1/2 HHMS	60	73317	Shim, 12mm Dia.
9	48037	Key, M6 x 30	35	11020	Belt, PT-20 Drive	61	73318	Shim, 15mm Dia.
10	70278	Scr, M10 x 25 HHMS	36	87099	Washer, M16	62	73319	Spring, PT-20 Brush Lock
11	14463	Bushing, 3/8 ID x 1/2 OD x .38	37	57129	Nut, M16 x 1.50 Torque Lock	63A	02095	Brush, PT-20 Nylon
12	41148	Housing, PT-20 Reduction Gearbox	38	64044	Pulley, PT-20 Reduction	638	02096	Brush, PT-20 Polypro
13	36087	Gasket, PT-20 Reduction Gearbox	39	70274	Scr, 5/16-18 3/4 FHMS	63C	02097	Brush, PT-20 Extra Aggressive
14	36088	Gear, PT-20 Reduction Crown	40	70286	Eye-Bolt, Turnbuckle	63D	02098	Pad Driver, PT-20
15	27307	Cover, Reduction Gearbox	41	14486	Bracket, Motor Pivot	64	59020	O-Ring, 4125
16	87098	Washer, M8 Lock	42	67113	Rod, Drive Motor Mounting	65	57133	Nut, M24 x 2 Lock
17	70311	Scr, M8 x 20 HHMS	43	78196	Tube, PT-20 Solution	66	73320	Shim, M47 x 0.3
18	36089	Gasket, Breather	44	67132	Ring, 1/2 Ext Snap H-D	67	67144	Ring, M47 Int Snap
19	14550	Breather	45	48033	Key, 5 x 5 x 20 mm	68	73313	Seal, M30 x 47 x 7 Oil
20	57047	Nut, M10	46	09032	Bearing, PT-20 Drive 6303	69	36090	Gear, Reduction Pinion
21	70312	Scr, M10 x 70 HHCS	47	73316	Spacer, PT-20 Drive	70	67143	Ring, M60 Ext Snap
22	53151	Motor, PT-20 24VDC Drive	48	57114	Nut, 7/16-14 Hex	71	62202	Plate, PT-20 Brush Holder
23	14538	Term Block, PT-20 2 Position	49	78178	Turnbuckle	72	70304	Scr, 1/4-20 x 1.25 FHWS
24	14551	Brush Set, PT-20 Drive Motor	50	57085	Nut, 3/8-16 Hex Jam	73	51076	Lug, Brush Mounting
25	57105	Nut, 1/4-20 Hex w/Star Washer	51	73267	Spring, Drive Belt Tension	74	36076	Gearbox Asm, PT-20 Reduction
26	70305	Scr, 5/16-18 x 3/4 HHCS	52	87003	Washer, 3/8 ID x 7/8 OD			

Product Modification

Pi-20 BATTERY SCRUBBER

Beginning with Serial #1700 the following changes were made to the brush drive as shown on Page 16 in the .service manual. Retain this notice in your manual for reference when ordering replacement parts.

1. Key #44 — Changed to rod with lock nuts, replacing the snap rings.
2. Keys #1-2-3-4-6-35-72-73-74-75-76-77 — Changed drive plate, brush drive lock, and new gear unit assembly.

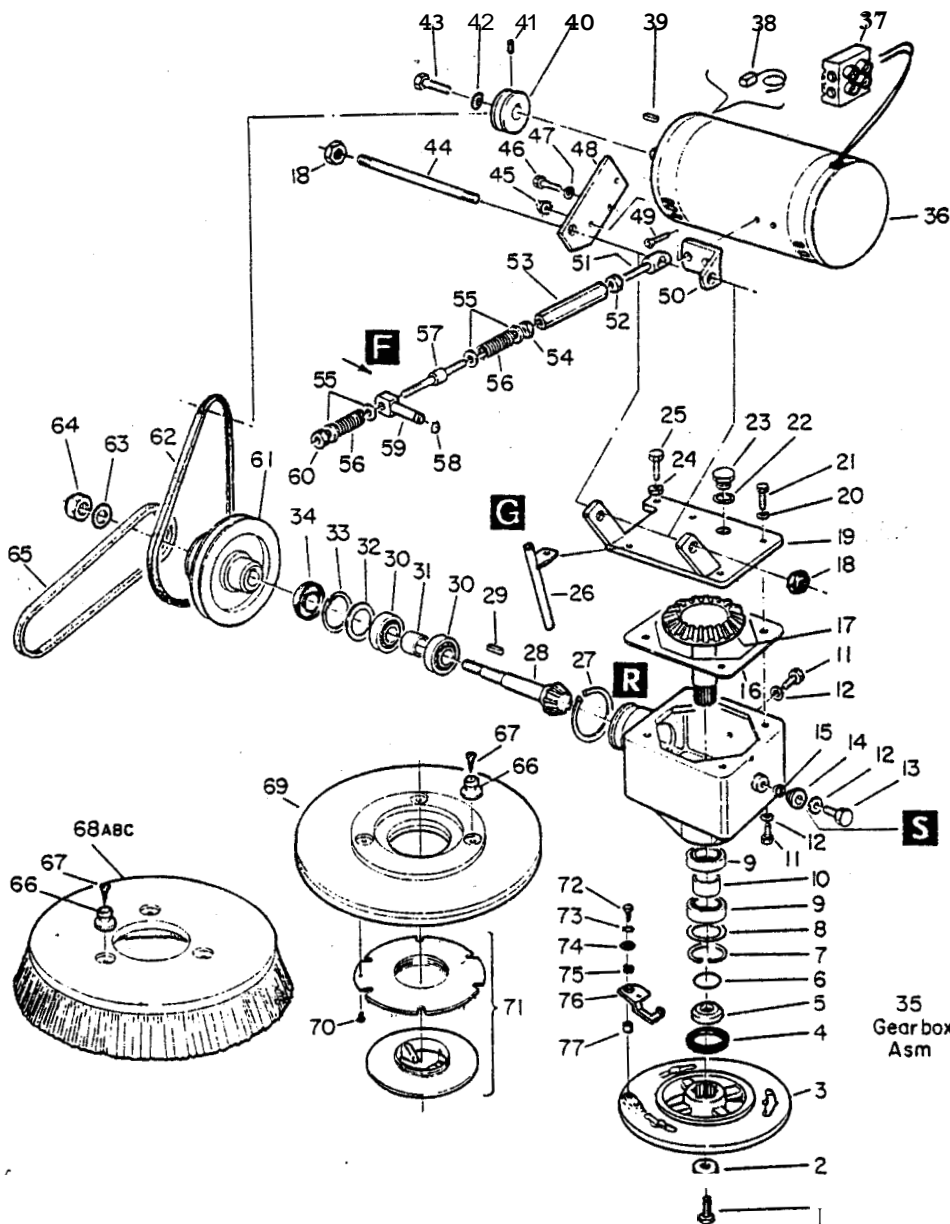

BRUSH DRIVE		
KEY	PART NO.	DESCRIPTION
1	70262	Scr, M8 x 20 HHMS
2	73438	Spacer, Brush Drive
3	62218	Plate, Brush Drive
4	73431	Seal, M38 x 52 x 8 Oil
5	73432	Spacer, PT20 Gearbox
6	59022	O-Ring, 1.187 OD x .094 BUNA-N
7	67142	Ring, 52mm Int Snap
8	73314	Shim, 52 x 0.3 mm
9	09031	Bearing, PT20 Reduction
10	73315	Spacer, PT20 Reduction
11	70310	Scr, M10 x 10 HHCS
12	87086	Washer, M10 x 30
13	70278	Scr, M10 x 25 HHMS
14	14463	Bushing, 3/8 ID x 1/2 OD x .38
15	59019	O-Ring, 3/8 ID x 3/32 BUNA-N
16	36087	Gasket, PT20 Reduction Gearbox
17	36088	Gear, PT20 Reduction Crown
18	57153	Nut, 1/2-13 Lock (Thin)
19	27307	Cover, PT20 Reduction Gearbox
20	87098	Washer, M8 Lock
21	70311	Scr, M8 x 20 HHMS
22	36089	Gasket, Breather
23	14550	Breather
24	57077	Nut, M10 Hex
25	70312	Scr, M10 x 70 HHCS
26	78196	Tube, Solution
27	67109	Ring, 2 1/8 Ext Snap
28	36090	Gear, Reduction Pinion
29	48033	Key, 5 x 5 x 20mm
30	09032	Bearing, Drive 6303
31	73316	Spacer, Drive
32	73320	Shim, M47 x 0.3
33	67144	Ring, M47 Int Snap
34	73313	Seal, M30 x 47 x 7 Oil
35	36079	Gearbox Assembly, Reduction
36	53151	Motor, 24 VDC Drive
37	14538	Term Block, 2-Position
38	14551	Brush Set, Drive Motor
39	48036	Key, Motor Pulley
40	64043	Pulley, Drive Motor
41	70314	Set Scr, 5/16-18 x 1/4 KCP
42	87008	Washer, 1/4 ID x 1 1/4 OD
43	70020	Scr, 1/4-20 x 1/2 HHMS
44	67229	Rod, Drive Motor Mounting
45	57105	Nut, 1/4-20 Hex w/Star Washer
46	70305	Scr, 5/16-18 x 3/4 HHCS
47	87083	Washer, 5/16 Split Lock
48	62199	Plate, Drive Motor Mtg
49	70274	Scr, 5/16-18 x 3/4 FHMS
50	14486	Brkt, Motor Pivot
51	70286	Eye-Bolt, Turnbuckle
52	57114	Nut, 7/16-14 Hex
53	78178	Turnbuckle
54	57085	Nut, 3/8-16 Hex
55	87003	Washer, 3/8 ID x 7/8 OD
56	73267	Spring, Drive Belt Tension
57	67112	Rod, Turnbuckle Sliding
58	67104	Ring, 5/8 Ext Snap
59	66105	Pin, Turnbuckle
60	57022	Nut, 3/8-16 Lock
61	64044	Pulley, Reduction
62	11021	Belt, Secondary Brush
63	87094	Washer, 5/8 Flat
64	57129	Nut, M16 x 1.50 Lock
65	11020	Belt, Drive
66	51076	Lug, Brush
67	70304	Scr, #14 x 1 1/4 FHWS
68A	02095	Brush Asm, 18" Nylon
68B	02096	Brush Asm, 18" Polypro
68C	02097	Brush Asm, 18" Extra Aggressive
69	02098	Pad Driver Assembly, 18"
70	70233	Scr, #10 x 3/8 PH Hi-Lo
71	51139	Lock, Big Mouth Syn Pad
72	70387	Scr, M5 x 12 HHCS
73	87016	Washer, #10 Star
74	87013	Washer, 1/4 Flat
75	73435	Spring, Brush Lock
76	51140	Lock, Brush Drive
77	73436	Spacer, Brush Lock

PT-20 TROUBLE-SHOOTING GUIDE

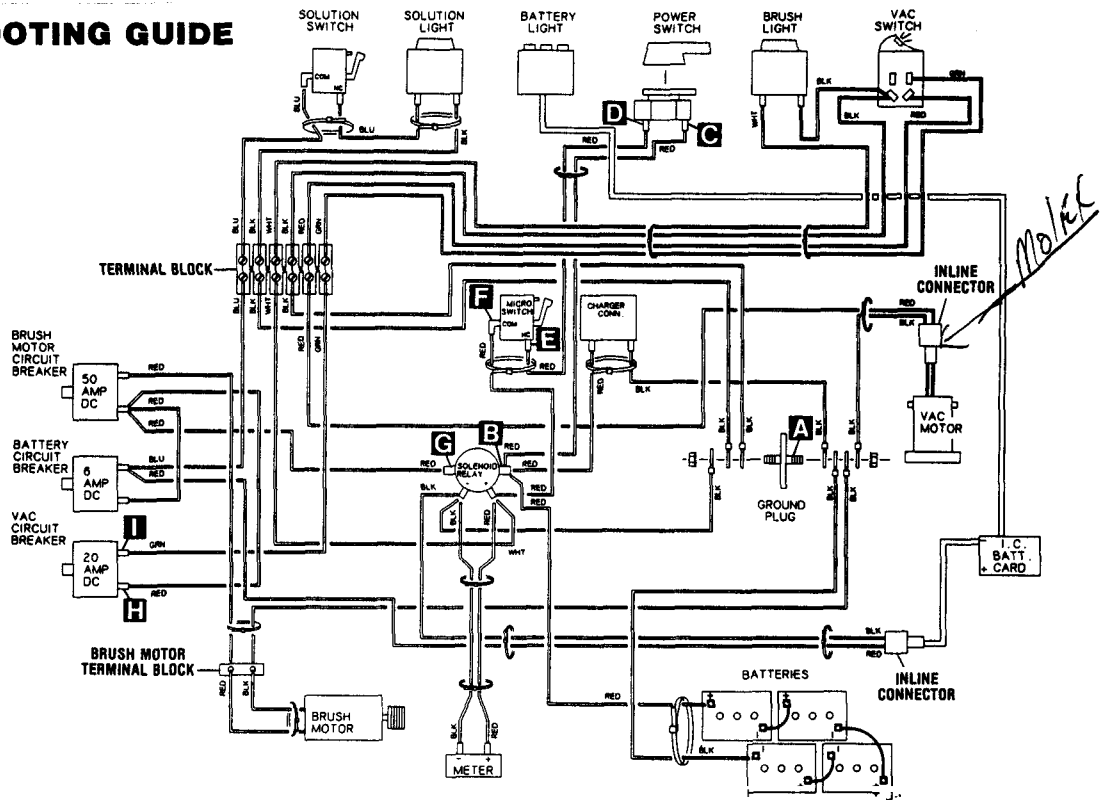

PROBLEM	PROBABLE CAUSE	CORRECTIVE ACTION
No power.	Circuit breaker tripped.	Reset brush motor circuit breaker (50 amp).
	Battery cables corroded at battery terminals.	1. Clean battery cable clamps and battery terminals. 2. Check voltage at points A and B. Voltage should be 22/26 VDC.
	Faulty main switch.	1. Check voltage at points A and C. Voltage should be 22/26 VDC. 2. Turn main switch on and check voltage at points A and D. Voltage should be 22/26 VDC. If no voltage remove leads and check switch for continuity,
	Faulty safety override micro switch.	With main switch "ON" check voltage at points A and E and A and F. Voltage should be 22/26 VDC. If no voltage at A and F remove leads and check micro switch for continuity. Should be continuity in normal position and no continuity when switch lever is activated.
Vacuum motor does not run.	Faulty solenoid.	With main switch on (solenoid energized) check voltage at points A and G — voltage should be 22/26 VDC. If no voltage replace solenoid.
	Circuit breaker tripped.	Reset vac motor circuit breaker.
	Loose connections.	Check motor lead connections at terminal block and inline connector near vac motor. Keep all connections tight.
	Faulty vac circuit breaker.	With main switch on check voltage at points A and H and A and I. If no voltage, check continuity of circuit breaker. Replace as needed.
Brush motor does not run.	Faulty vac switch.	Remove leads and check switch for continuity. Replace as needed.
	Motor brushes worn.	Check motor brushes. Replace when worn to 3/8". Check vac motor by securing motor and applying 24 VDC to motor leads. No load amp draw of motor should be 15 amp.
	Circuit breaker tripped.	Reset (50 amp) brush motor circuit breaker.
	Loose connection.	Check motor leads at terminal block connection (located under right hand lower side panel) tighten set screws as needed.
Solution light does not work.	Faulty solenoid.	With main switch on check output voltage at points A and G. Voltage should be 22/26 VDC.
	Faulty drive motor.	Check motor brushes — replace when worn to 3/8". With batteries fully charged and motor secured, apply battery voltage direct to motor. No load amp draw of motor should be 12 to 13 amps.
	Faulty circuit breaker.	Reset (6 amp) battery circuit breaker.
Battery charge level Indicator lights.	Loose connections.	Check for loose electrical connections at terminal block, solution switch, and solution light.
	Faulty solution light.	Remove light and apply direct battery voltage (24 VDC) to light. Replace light as needed. Adjust solution light switch.
Battery charge level Indicator lights.	Light stay on with solution lever in "OFF" position.	Remove light and apply direct battery voltage (24 VDC) to light. Replace light as needed. Adjust solution light switch.
	No light are on with main switch on.	Check (6 amp) battery circuit breaker. Reset if tripped.
Battery charge level Indicator lights.	Loose connections.	1. Check electrical connections at circuit breaker. 2. Check voltage at inline connector at PC Board. Should be 22/26 VDC.

Free Manuals Download Website

<http://myh66.com>

<http://usermanuals.us>

<http://www.somanuals.com>

<http://www.4manuals.cc>

<http://www.manual-lib.com>

<http://www.404manual.com>

<http://www.luxmanual.com>

<http://aubethermostatmanual.com>

Golf course search by state

<http://golfingnear.com>

Email search by domain

<http://emailbydomain.com>

Auto manuals search

<http://auto.somanuals.com>

TV manuals search

<http://tv.somanuals.com>