

OWNER'S MANUAL
INSTALLATION INSTRUCTIONS

WINEGARD®

RV DIGITAL SATELLITE SYSTEM

Models RD-4600 & RD-4646

U.S. PATENT NOS. 5,532,710
and 5,554,998
Made in U.S.A.

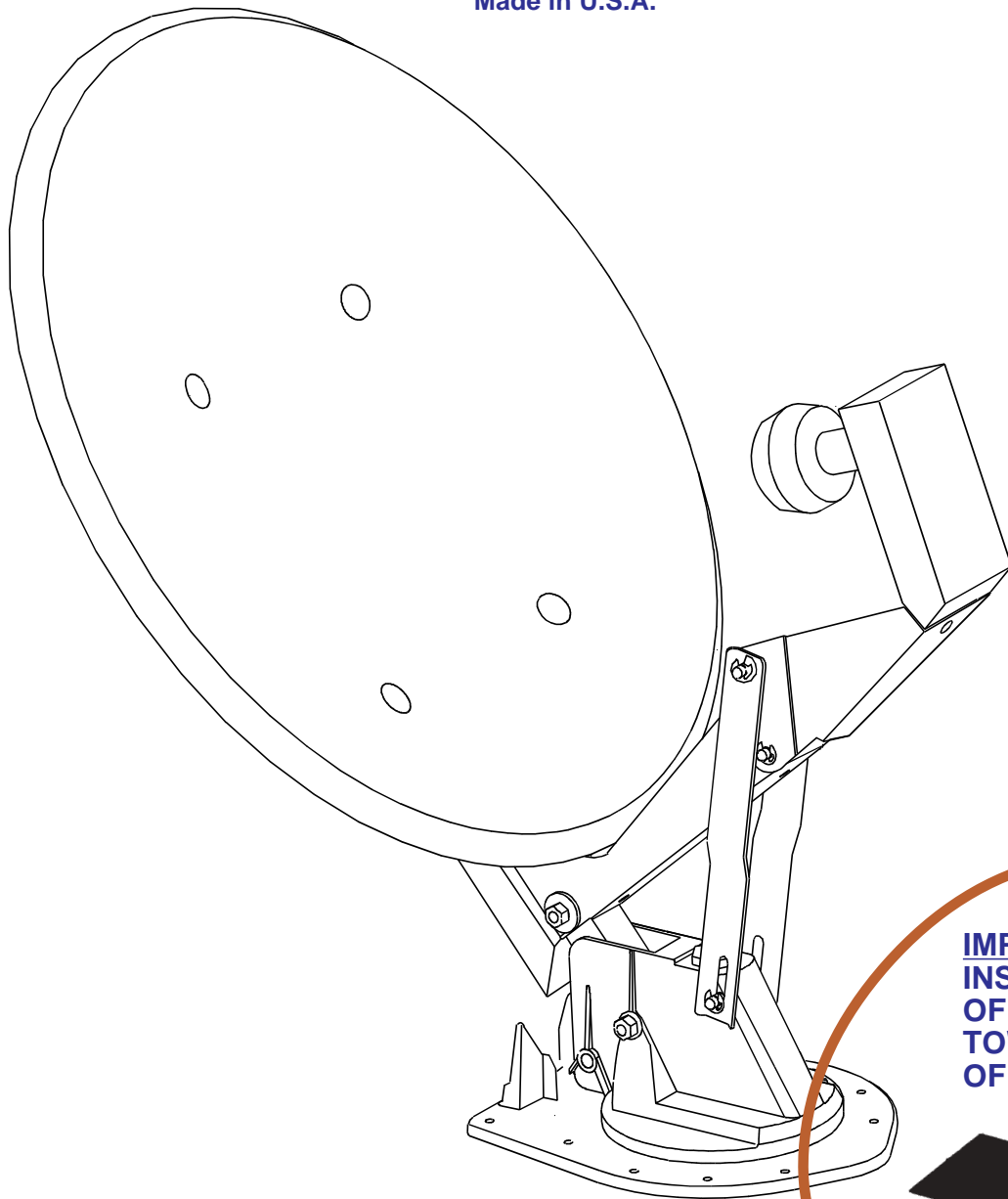

**IMPORTANT:
INSTALL POINT
OF BASE
TOWARD FRONT
OF VEHICLE!**



Winegard Company • 3000 Kirkwood St. • Burlington, IA 52601-2000
319/754-0600 • FAX 319/754-0787
Printed in U.S.A. © Winegard Company 2001 2451099 Rev. 6/05/01

INSTALLATION & ASSEMBLY

STEP 1. Choose a location for antenna that will allow it to rest in travel position with top of reflector pointing toward rear of vehicle and to raise and rotate without interfering with other roof-mounted equipment. Make sure inside ceiling area is clear where ceiling plate will mount.

NOTE: Figure 1 shows minimum distance (10") antenna should be located from edge of vehicle roof. We recommend you check with your dealer or the manufacturer to see what provisions have been made in the roof for antenna mounting. A reinforced area of roof as well as pre-wire download may be available.

NOTE: *The system must be level for proper operation.* If you have a curved roof you should use a Winegard Models RW-1000 IW-1001 wedge kits to level the system.

STEP 2. Position template on roof (pg. 15 this manual) and drill a 1-3/4" hole through roof and ceiling of vehicle. **Take care to avoid damage to wiring which may run between roof and ceiling.**

STEP 3. The mount is designed to fit roofs 1" to 6 3/4" thick. Cut elevating shaft and directional handle to size, see table below.

CAUTION: IF YOU ARE USING THE RW-1000 ROOF WEDGE, ADD 1/2" TO ELEVATING SHAFT LENGTH GIVEN BELOW, BUT NOT TO THE DIRECTIONAL HANDLE.

It is highly recommended that the antenna be mounted on roof center line. Do not mount antenna closer than 10" from edge of roof.

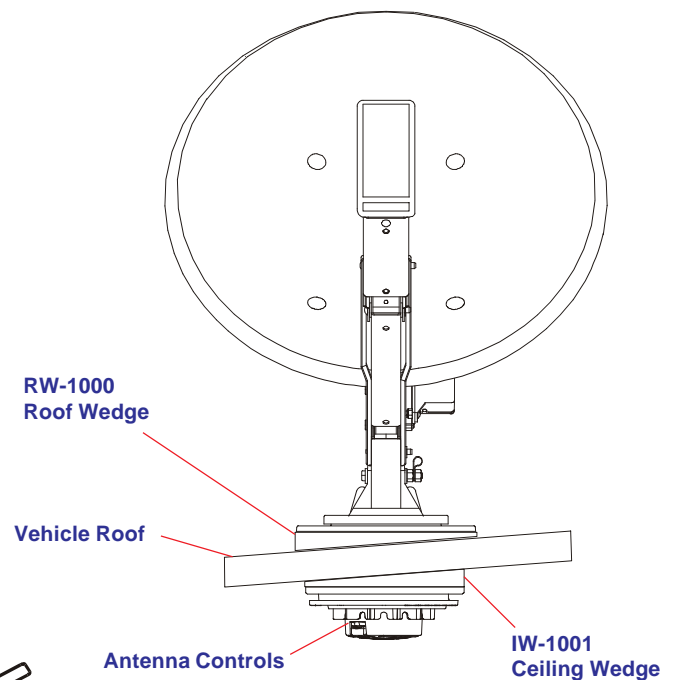
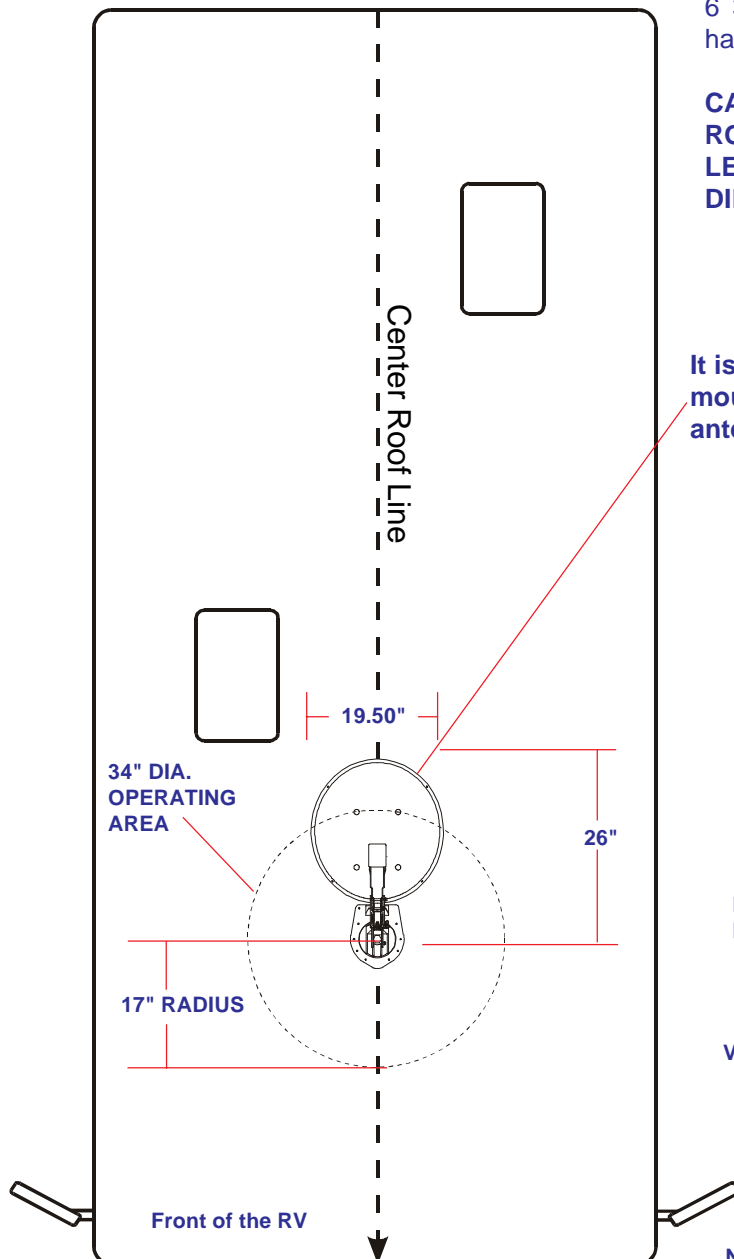

NOT TO SCALE

FIGURE 1

STEP 4. Attach reflector to backup assembly as shown in Figure 2.

NOTE: Make sure that coax cable fits between the reflector and the fixed feed arm.

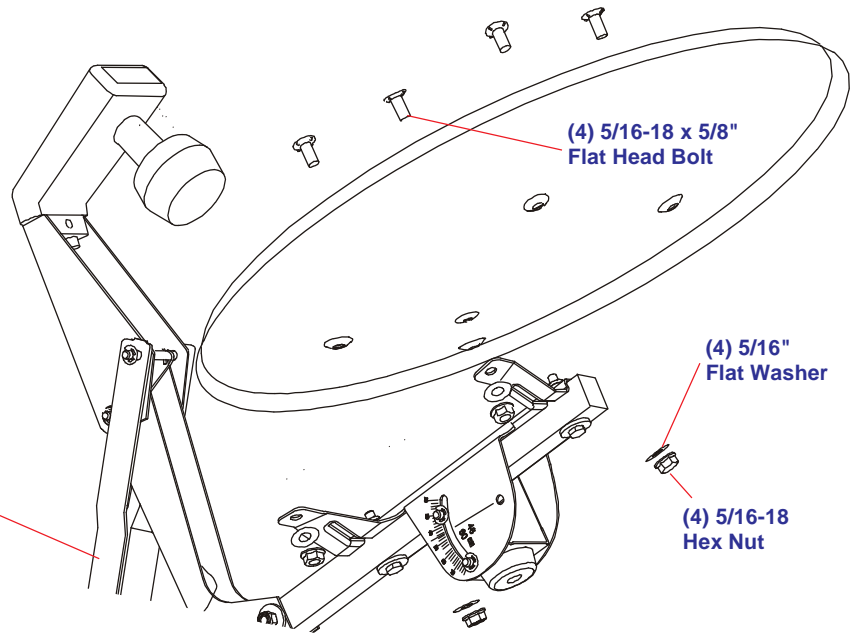

The mount is designed to fit roofs 1\"/>

CAUTION: IF YOU ARE USING THE RW-1000 ROOF WEDGE, ADD 1/2\"/>

| ROOF THICKNESS | ELEVATING SHAFT LENGTH | W/RW-1000 | DIRECTIONAL HANDLE LENGTH |
|----------------|------------------------|--------------|---------------------------|
| 4 3/4" | 6 1/4" | RP-4200 req. | 5 3/8" |
| 4 1/2" | 6" | RP-4200 req. | 5" |
| 4 1/4" | 5 3/4" | 6 1/4" | 4 3/4" |
| 4" | 5 1/2" | 6" | 4 1/2" |
| 3 3/4" | 5 1/4" | 5 3/4" | 4 1/4" |
| 3 1/2" | 5" | 5 1/2" | 4" |
| 3 1/4" | 4 3/4" | 5 1/4" | 3 9/16" |
| 3" | 4 1/2" | 5" | 3 3/8" |
| 2 3/4" | 4 1/4" | 4 3/4" | 3 1/16" |
| 2 1/2" | 4" | 4 1/2" | 2 3/4" |
| 2 1/4" | 3 3/4" | 4 1/4" | 2 3/8" |
| 2" | 3 1/2" | 4" | 2 1/16" |
| 1 3/4" | 3 1/4" | 3 3/4" | 1 3/4" |
| 1 1/2" | 3" | 3 1/2" | 1 3/8" |
| 1 1/4" | 2 3/4" | 3" | 1" |

FIGURE 2

STEP 5. Mount antenna and lift on roof in travel position. Apply a liberal amount of approved nonhardening sealing compound on bottom of base plate and roof area around hole. See Figure 3. Secure base plate with screws provided.

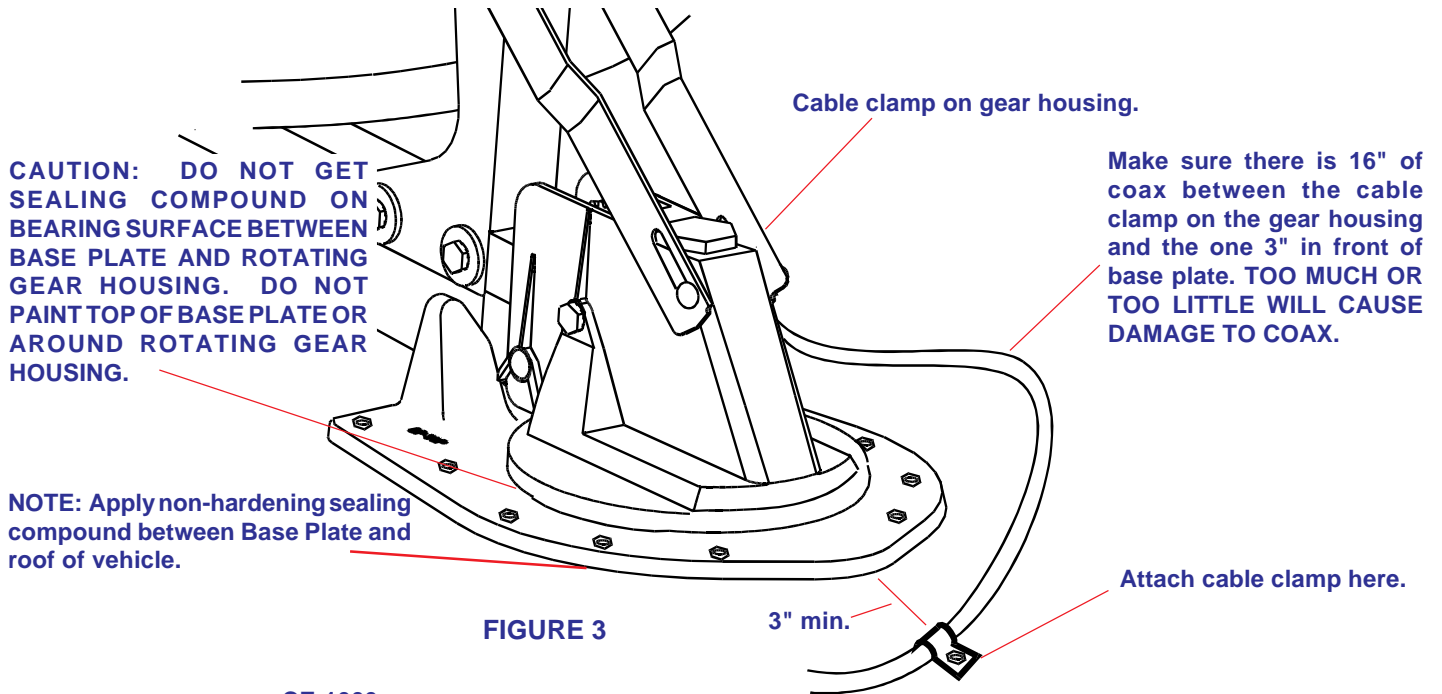

FIGURE 3

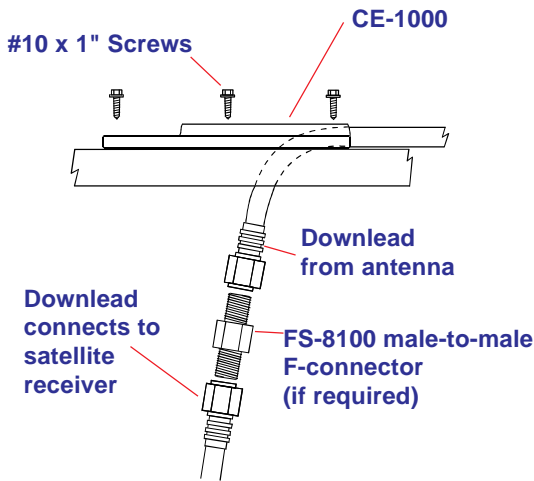

FIGURE 3A

STEP 6. Attach cable clamp to the coax cable 16" from the cable clamp on the gear housing.

STEP 7. Attach cable clamp to roof **3" in front of baseplate** as shown in Figure 3, use 7/16" flat washer between screw head and clamp, apply sealing compound over mounting screw head.

STEP 8. Feed downlead through the roof using a Model CE-1000 cover plate (included with hardware), Figure 3A. **Weatherproof cable entry** by applying sealant under lip of roof-thru plate and where cable enters roof. Attach plate to roof with screws provided. Apply sealant over screws and around edge of roof-thru plate, making sure cable entry is sealed. Secure cables as necessary to prevent whipping. **DO NOT MAKE CONNECTION ON TOP OF ROOF unless there is no other option, it is very difficult to weatherproof outside connection. If downlead connection is made on top of roof make sure to weatherproof connection!**

INSIDE RV

STEP 9. Assemble ceiling plate, directional handle and crank handle as shown in Figure 5. The circled numbers indicate placement from the ceiling down. **Example:** The ceiling plate ① is located next to the ceiling. The elevation crank handle ⑧ is farthest from the ceiling. The number also indicates sequence of assembly.

NOTE: When installing polyethylene shim, # 3, page 5, slide shim onto shaft as far as it will go. Then slide directional handle up over shaft and shim and onto the gear housing. Two shims are supplied in case one is not enough to create a snug fit between directional handle and gear housing.

CAUTION: USE CAUTION WHEN INSTALLING THE ELEVATING CRANK. ONCE SCREW TOUCHES SHAFT, TIGHTEN ONLY 1/4 TURN MORE. SCREW SIMPLY HOLDS ELEVATING CRANK ON. DO NOT OVERTIGHTEN!

CAUTION: After INITIAL INSTALLATION, the antenna SHOULD ROTATE APPROXIMATELY 360 DEGREES FROM TRAVEL POSITION.

The pointer on the DIRECTIONAL HANDLE should point towards the ROTATION CLAMP when in TRAVEL POSITION.

FIGURE 8

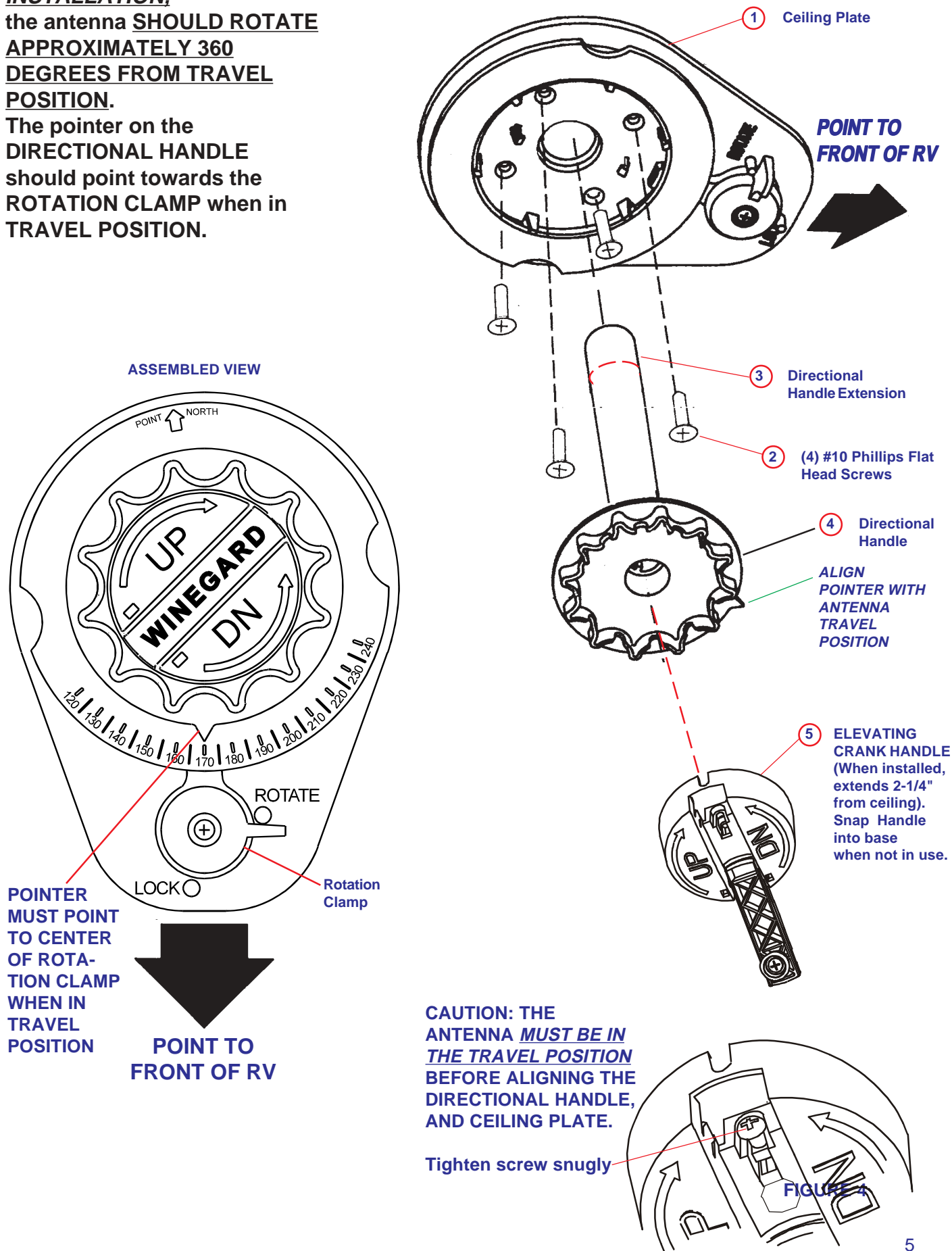

OPERATION

STEP 1. Using a compass, determine which direction is North. It is recommended that you step outside to perform this step. Standing in or near coach/RV can give you an incorrect reading. The more accurately you determine North, the easier it will be to find the satellite(s).

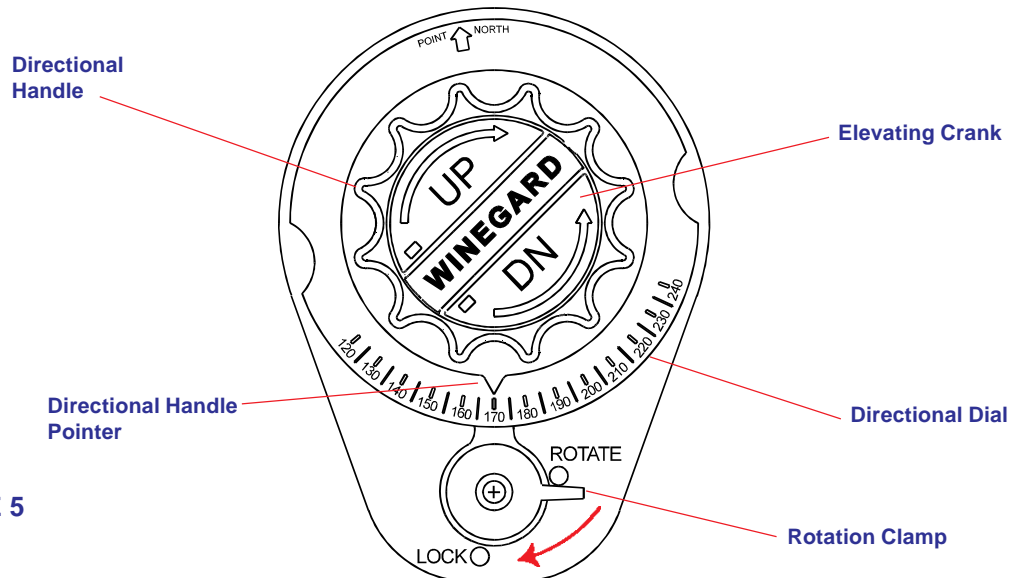

FIGURE 5

STEP 2. Move rotation clamp to the **LOCK** position.

STEP 3. Turn directional dial (see Figure 5) until the arrow is pointing North.

STEP 4. Unsnap elevation crank and turn (clockwise) in direction of "UP" arrow, about 14 - 15 turns or until some resistance is met.

STEP 5. Turn receiver ON, and access installation menus to determine antenna elevation and direction/heading.

STEP 6. Move rotation clamp to the **ROTATE** position. Turn directional handle until pointer on directional handle is pointing in direction indicated by the receiver. Example: If receiver says point antenna at 145° then rotate directional handle so that pointer is pointing at 145° on the directional dial.

| ELEVATION | TURNS CCW |
|-----------|-----------|
| 14 - 16° | NONE |
| 17 - 19° | 1/2 |
| 20 - 22° | 1 |
| 23 - 26° | 1-1/2 |
| 27 - 29° | 2 |
| 30 - 32° | 2-1/2 |
| 33 - 36° | 3 |
| 37 - 39° | 3-1/2 |
| 40 - 43° | 4 |
| 44 - 46° | 4-1/2 |
| 47 - 50° | 5 |
| 51 - 53° | 5-1/2 |
| 54 - 57° | 6 |
| 58 - 60° | 6-1/2 |
| 61 - 64° | 7 |
| 65 - 67° | 7-1/2 |

STEP 7. Refer to table below and turn elevation crank counter clockwise (CCW) the number of turns indicated to get the elevation shown by the receiver. One full turn equals approximately 7° of elevation change.

TUNING ANTENNA FOR BEST PICTURE

STEP 8. Your receiver should indicate it is receiving a signal. To tune your antenna for the best picture **slowly** move the antenna left, then right until you have found the position that gives the highest signal strength. **It is important to turn the antenna slowly; since the signal is digital the receiver takes a few seconds to lock on.**

STEP 9. Place rotation clamp in the **LOCK** position. This prevents the antenna from moving and losing the signal.

STEP 10. **Slowly** raise then lower the antenna until you have peaked the signal. **You are now ready to watch satellite TV!**

LOWERING ANTENNA TO TRAVEL POSITION

STEP 1. Set rotation clamp to the **ROTATE** position.

STEP 2. Rotate antenna until pointer on directional handle aligns with the rotation clamp.

STEP 3. Turn elevating crank (counter clockwise) **in direction of "DOWN" arrow until resistance is met.** The number of turns will vary according to the elevation angle the antenna was set to.

STEP 4. Move rotation clamp to the LOCK position. Antenna is now locked in travel position.

STEP 5. Snap elevation crank into place.

CAUTION: UNDER NO CONDITIONS LOWER ANTENNA IN ANY POSITION EXCEPT TRAVEL POSITION.

DO'S

1. *Do* check parking location for obstructions before raising antenna.
2. *Do* carefully raise, lower and rotate - if difficult, check for cause.
3. *Do* rotate slowly when searching for the satellite(s) and check fine tuning on TV set to make sure it is properly adjusted.
4. ***Do* lower antenna before moving vehicle.**
5. Activate programming by calling programming service for your receiver.

DON'T'S

1. ***Don't* move RV/coach with the antenna in the UP position. This will VOID your warranty. This may also cause damage to your roof.**
2. *Don't* force elevating crank up or down. Check for cause of trouble.
3. *Don't* rotate directional handle hard against stops.
4. *Don't* apply paint over top of base plate or anywhere on lift.
5. *Don't* apply sealing compound on gear housing.

MAINTENANCE

MOUNT LUBRICATION

To lubricate the mount, apply a liberal amount of silicone spray lubricant to the elevating gear, the lubricate hole and between the gear housing and baseplate. Run the antenna up/down and rotate the antenna to distribute the lubricant. See Figure 6.

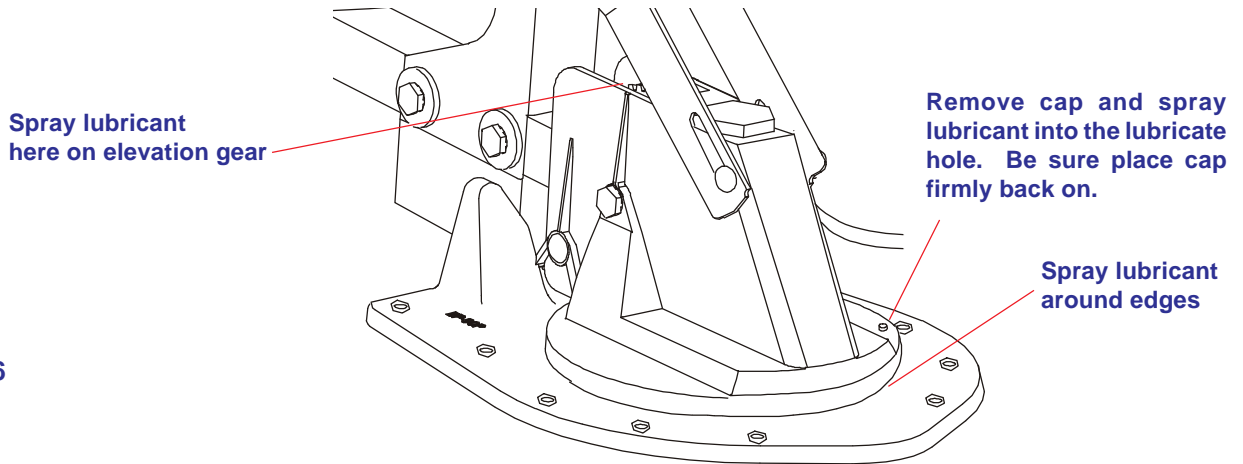

FIGURE 6

LUBRICATING RUBBER QUAD RING

Lubricate rubber quad ring on elevating shaft which is below worm gear with silicone spray lubricant at least **twice yearly** (Figure 8). This will keep quad ring from becoming brittle which could result in leaks down elevating shaft.

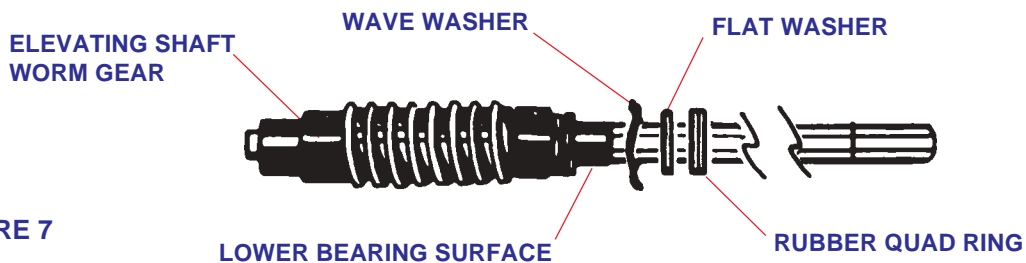

FIGURE 7

ELEVATING SHAFT & WORM GEAR ASSEMBLY REPLACEMENT PROCEDURE

NOTE: It is not necessary to remove rotating gear housing from base plate or remove antenna from roof to replace the shaft & worm gear assembly.

- STEP 1.** Lower antenna to travel position. Loosen screw on elevating crank, remove crank, spring, directional handle. Parts list page 12.
- STEP 2.** Remove hex nuts, cable clip, and washer from bolt holding elevating tube in rotating gear housing and remove bolt. Parts list page 10.
- STEP 3.** Remove plastic plug from top of rotating gear housing, disengage elevating gear, remove elevating shaft assembly. Parts list page 10.
- STEP 4.** Lubricate worm gear assembly on new elevating shaft assembly with spray silicone lubricant. **Make sure wave washer, flat washer and quad ring are on lower bearing** (Figure 7) and insert assembly in housing.
- STEP 5.** Reinstall plastic plug in top of housing. Gears will mesh automatically once elevating crank is turned.
- STEP 6.** Reinstall bolt, hex nuts, cable clip and washers that hold elevating tube in rotating gear housing.
- STEP 7.** Replace directional handle, spring and elevating crank. Make sure set screw contacts flat surface on shaft before tightening.

TROUBLE SHOOTING

NO PICTURE

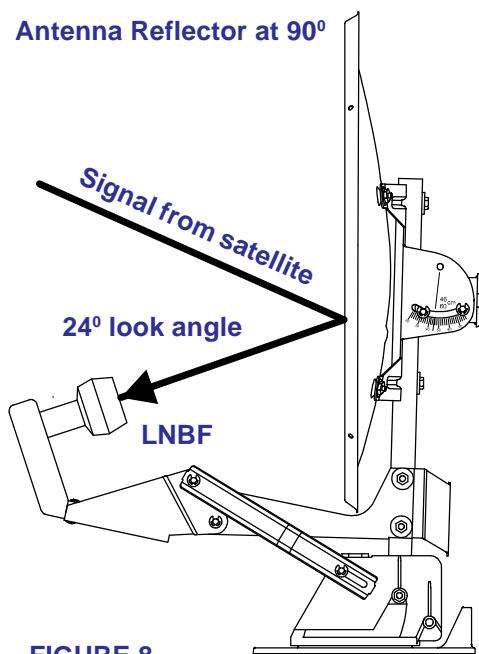

FIGURE 8

1. Check that you have a clear line of sight to the satellite (no trees, buildings, etc.).
2. Check that you have the TV set tuned for the correct channel 3 or 4 (same channel as output of receiver).
3. Double check that you have entered the correct zip code into the receiver. If zip code is wrong, this can cause you to look in the wrong direction/elevation for the satellite.
4. Check that there are no obstructions blocking the view of the satellites. The signal from the satellite(s) **WILL NOT** pass through trees, buildings, mountains etc. Remember that the antenna has a 24° offset, this means that when the antenna is straight up and down (90°) it is looking 24° into the sky. See Figure 8.
5. Check connections at receiver, TV, and antenna.
6. Check TV. Does it receive pictures from off-air TV stations/VCR?
7. Retune system for best picture per procedure on page 7.
8. Inspect antenna. Make sure that it has not been damaged. If antenna is even slightly bent, the receiver may not receive any signal.
9. Contact Dealer or Winegard Service Department.

ANTENNA DOES NOT OR IS HARD TO ROTATE

S:\RV-DSSI\4600-90.CDR

1. Inspect antenna on roof. Make sure that mount has not been damaged.
2. Check for caulking between gear housing and baseplate.
3. Lubricate mount per procedure on page 8.
4. Contact Dealer or Winegard Service Department.

ANTENNA DOES NOT OR IS HARD TO RAISE

1. Inspect antenna on roof. Make sure that mount has not been damaged.
2. Check for caulking on elevating shaft.
3. Lubricate elevating shaft per procedure on page 8.
4. Contact Dealer or Winegard Service Department.

WARRANTY REPAIR WORK

Before you have warranty work done on the system, make sure the company/person performing the work has been approved by Winegard Company. If not, contact Winegard Co. (1-800-288-8094) before proceeding. The Winegard warranty covers only the mount, antenna and LNBF. **For receiver warranty, refer to the manufacturer's warranty.**

ORDERING REPAIR PARTS

Repair parts are available at many RV dealers and/or service centers throughout the country. Or you can call Winegard Company 1-800-288-8094 (credit cards accepted).

PARTS LIST

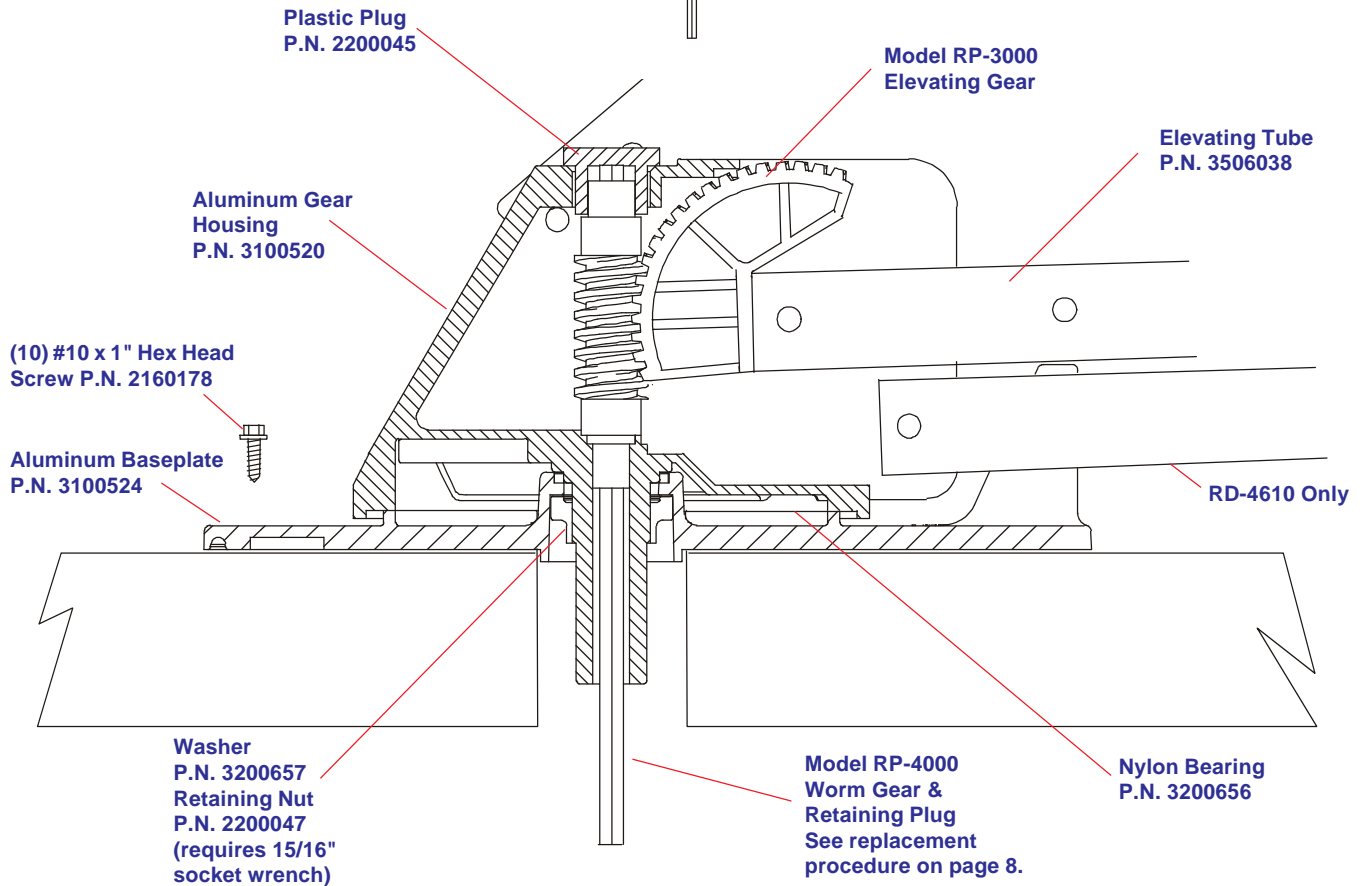
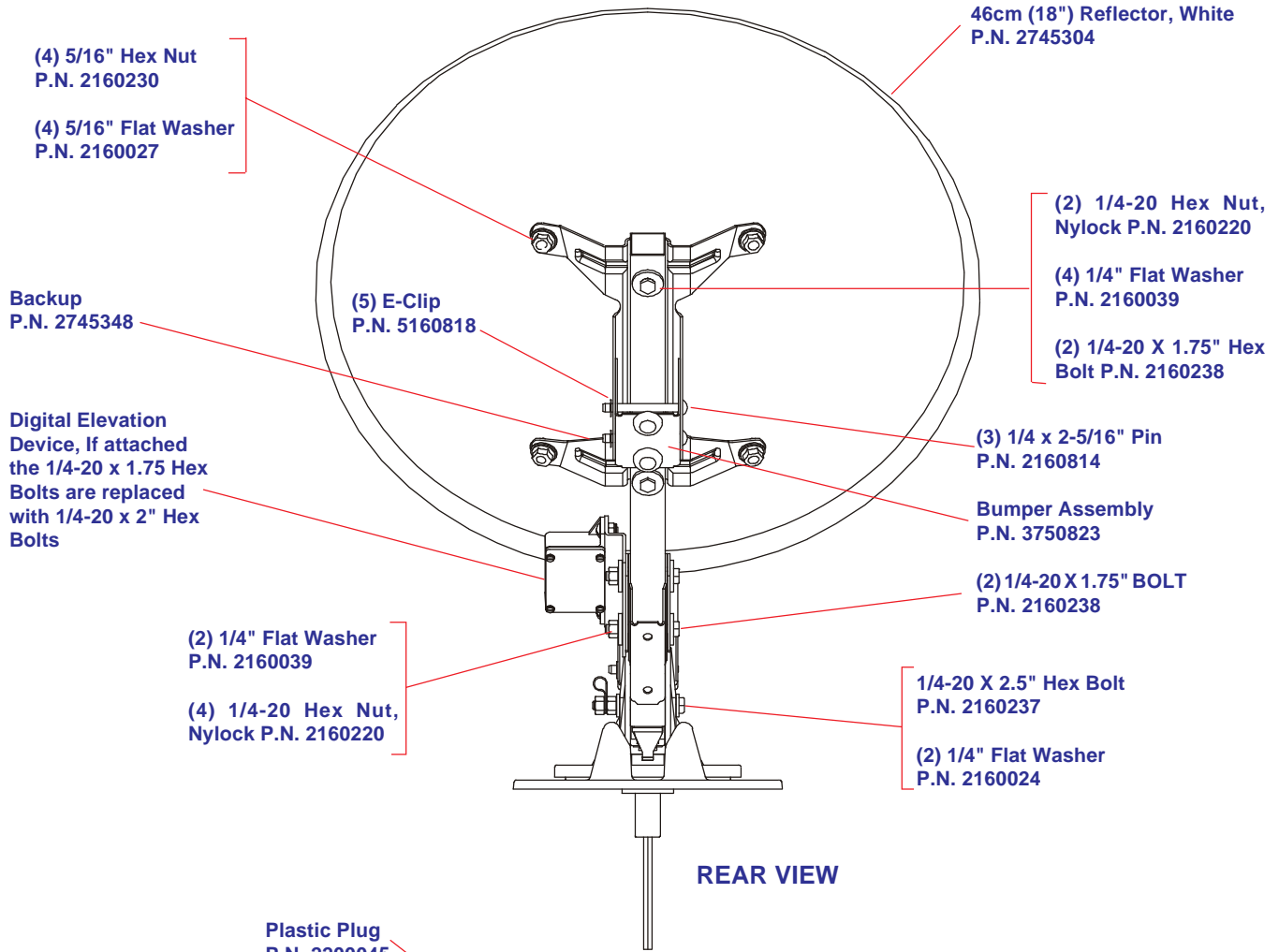

PARTS LIST

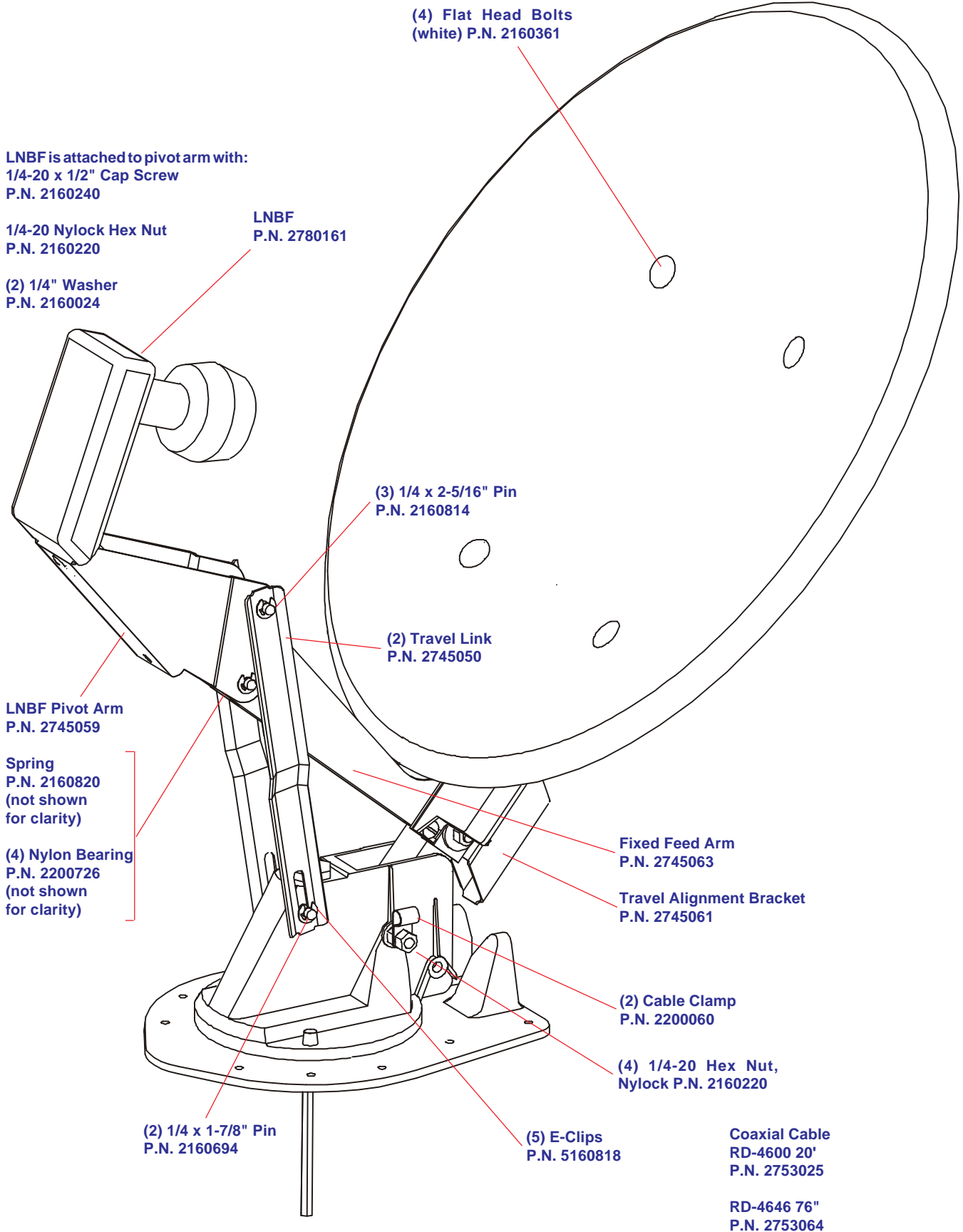

PARTS LIST

**INTERIOR HARDWARE KIT
RK-CEIL**

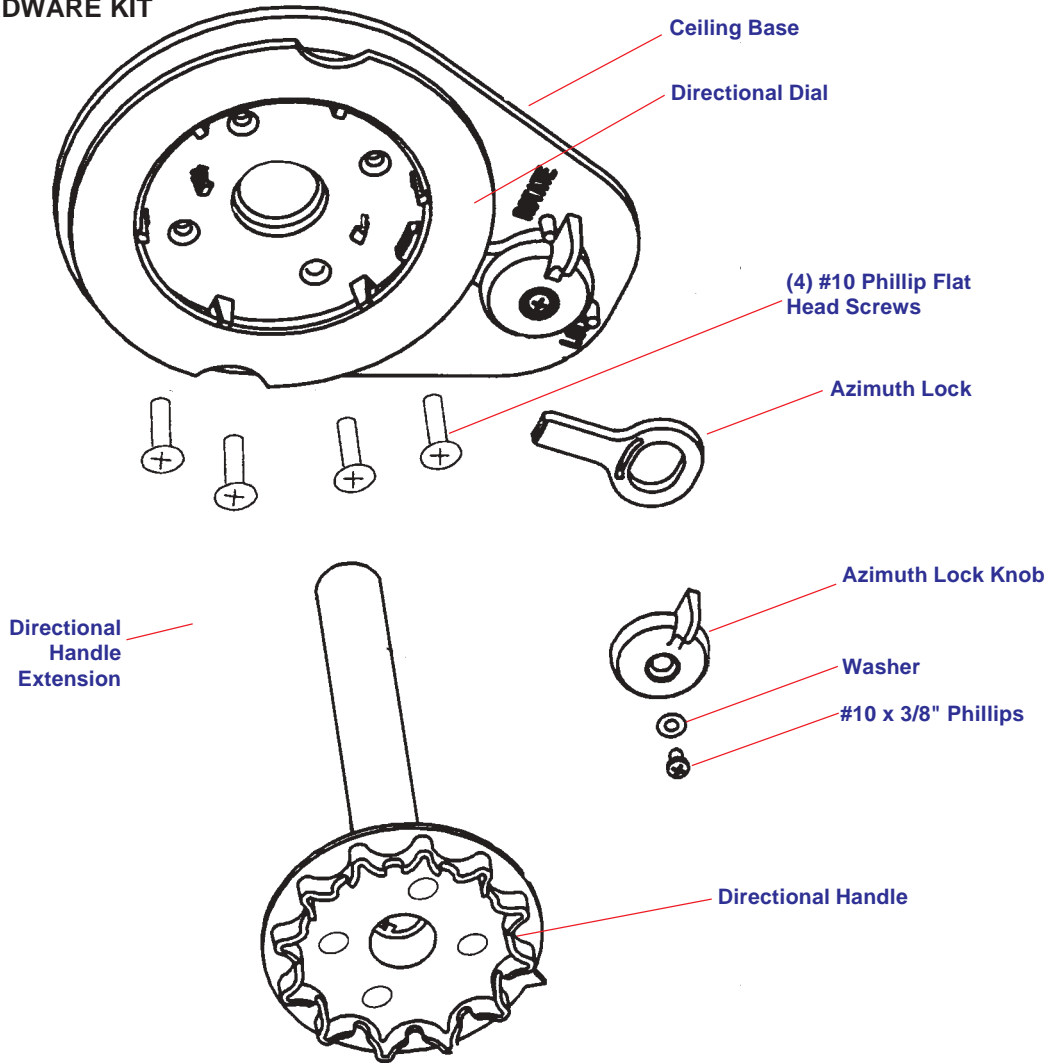

**CRANK HANDLE KIT
RK-HAND**

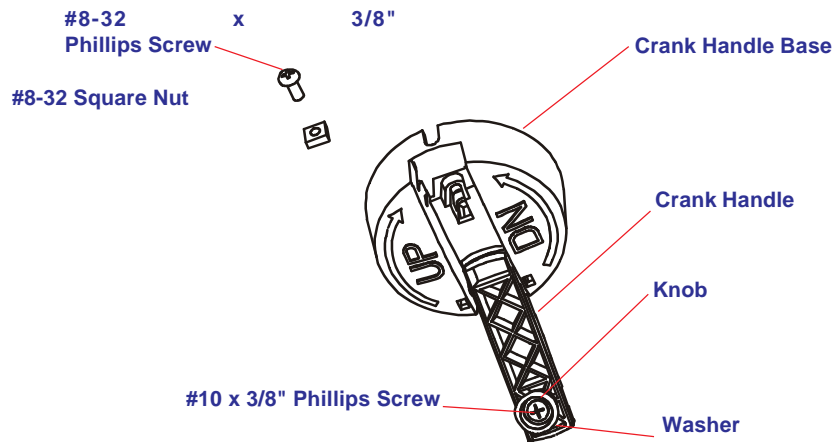

SPECIFICATIONS

ANTENNA & MOUNT

| | |
|-------------------------------|--|
| Height when raised | 27.25" max. |
| Height in the travel position | 12.0" max. |
| Operating radius | 17" (34" diameter circle) |
| Roof space required | 19.5" x 31" |
| LNB | Compatible with DSS® and DISH Network™ |
| Weight | 13 lbs. max. |
| Color | White |
| Antenna height | 20.9" |
| Antenna width | 19.5" |
| F/D | 0.59 |
| Offset angle | 24° |
| Frequency range | 10.95 - 12.75 GHz |
| Gain: | |
| 11.2 GHz | 33.22 dBi |
| 12.1 GHz | 33.89 dBi |
| 12.6 GHz | 34.23 dBi |
| Aperture efficiency | 73% |
| Cross polarization (on axis) | -21 dB |
| *Beamwidth at -3 dB | 3.5° |
| *Beamwidth at -10 dB | 7.0° |
| Wind loading | Up to hurricane force |
| Shipping weight: | 16 lbs. |

DSS® is a registered trademark of DIRECTV, Inc., a unit of Hughes Electronics Corporation.

DISH Network™ is a trademark of EchoStar Communications Corporation.

ANTENNA/LIFT/LNBF TWO YEAR LIMITED WARRANTY

Winegard Company warrants this Winegard product (excluding receiver) against any defects in materials or workmanship within two (2) years from date of purchase. No warranty claim will be honored unless at the time the claim is made, you present proof of purchase to an authorized Winegard dealer (if unknown, please contact Winegard Company, 3000 Kirkwood Street, Burlington, Iowa 52601-2000, telephone 319-754-0600).

Winegard Company (at its option) will either repair or replace the defective product at no charge to you. This warranty covers parts, but does not cover any costs incurred in removal, shipping or reinstallation of the product. This limited warranty does not apply if the product is damaged, deteriorates, malfunctions or fails from: misuse, improper installation, abuse, neglect, accident, tampering, modification of the product as originally manufactured by Winegard, usage not in accordance with product instructions or acts of nature such as damage caused by wind, lightning, ice or corrosive environments such as salt spray and acid rain.

The Two Year Warranty is provided on the condition that the equipment is properly delivered with all handling and freight charges prepaid to your Winegard dealer for repair or return to our factory at the above address. Winegard dealers will arrange for the replacement or repair and return to you, without charge, the product which failed due to defective material or workmanship.

WINEGARD COMPANY WILL NOT ASSUME ANY LIABILITIES FOR ANY OTHER WARRANTIES, EXPRESS OR IMPLIED, MADE BY ANY OTHER PERSON.

ALL OTHER WARRANTIES WHETHER EXPRESS, IMPLIED OR STATUTORY INCLUDING WARRANTIES OF FITNESS FOR A PARTICULAR PURPOSE AND MERCHANTABILITY ARE LIMITED TO THE TWO YEAR PERIOD OF THIS WRITTEN WARRANTY.

The foregoing shall be the sole and exclusive remedy of any person whether in contract, tort or otherwise, and Winegard shall not be liable for incidental or consequential damage or commercial loss, or from any other loss or damage except as set forth above.

Some states do not allow limitations on how long an implied warranty lasts, or the exclusion of limitation of incidental or consequential damages, so the above limitations or exclusions may not apply to you.

This warranty gives you specific legal rights and you may also have other rights which vary from state to state.

Roof Template Goes Here

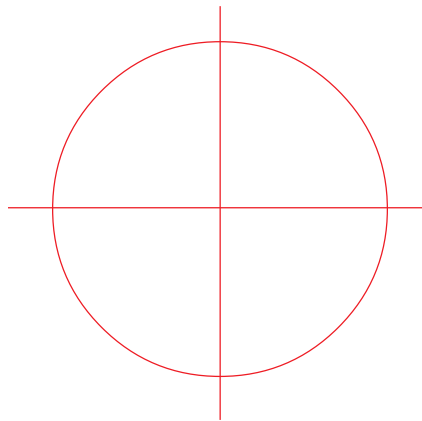

1-3/4" DIA.
DRILL COMPLETELY
THROUGH CEILING

TOWARD FRONT
OF VEHICLE

1/8" DRILL BIT
10 HOLES. DO NOT
DRILL THROUGH CEILING.

Free Manuals Download Website

<http://myh66.com>

<http://usermanuals.us>

<http://www.somanuals.com>

<http://www.4manuals.cc>

<http://www.manual-lib.com>

<http://www.404manual.com>

<http://www.luxmanual.com>

<http://aubethermostatmanual.com>

Golf course search by state

<http://golfingnear.com>

Email search by domain

<http://emailbydomain.com>

Auto manuals search

<http://auto.somanuals.com>

TV manuals search

<http://tv.somanuals.com>